

HD74LS373

Octal D-type Transparent Latches (with three-state outputs)

REJ03D0482-0200

Rev.2.00

Feb.18.2005

The HD74LS373, 8-bit register features totem-pole three-state outputs designed specifically for driving highly-capacitive or relatively low-impedance loads. The high-impedance third state and increased high-logic-level drive provide this register with the capacity of being connected directly to and driving the bus lines in a bus-organized system without need for interface or pull-up components. They are particularly attractive for implementing buffer registers, I/O ports, bidirectional bus drivers, and working registers.

The eight latches are transparent D-type latches meaning that while the enable (G) is high the Q outputs will follow the data (D) inputs. When the enable is taken low the output will be latched at the level of the data that was setup.

Features

- Ordering Information

Part Name	Package Type	Package Code (Previous Code)	Package Abbreviation	Taping Abbreviation (Quantity)
HD74LS373P	DILP-20 pin	PRDP0020AC-B (DP-20NEV)	P	—
HD74LS373FPEL	SOP-20 pin (JEITA)	PRSP0020DD-B (FP-20DAV)	FP	EL (2,000 pcs/reel)
HD74LS373RPEL	SOP-20 pin (JEDEC)	PRSP0020DC-A (FP-20DBV)	RP	EL (1,000 pcs/reel)

Note: Please consult the sales office for the above package availability.

Pin Arrangement

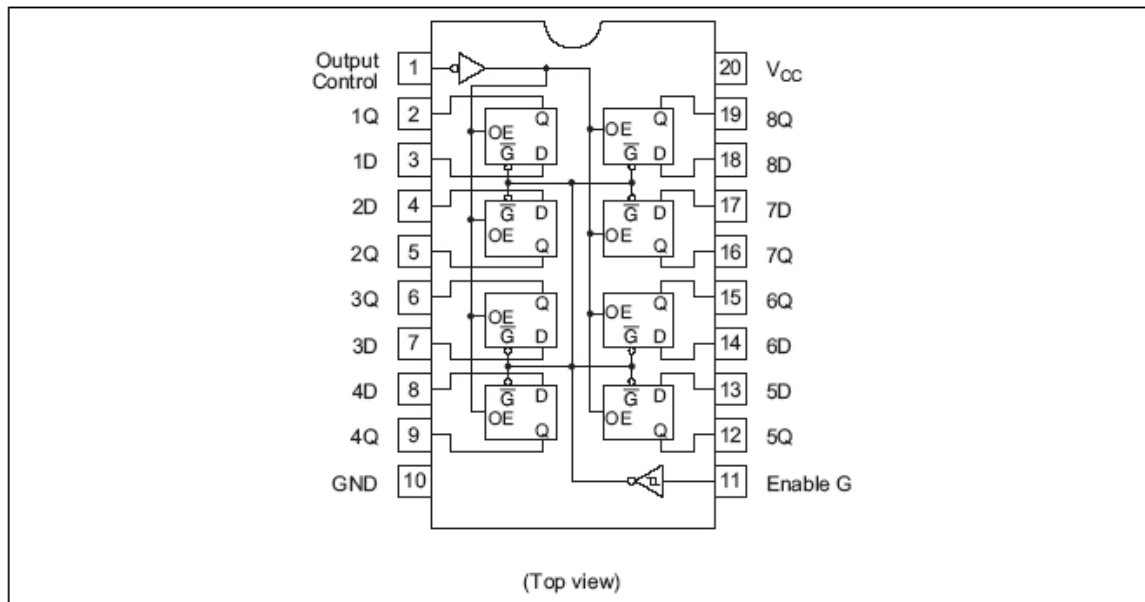

Function Table

Inputs		Output
Output control	Enable G	Q
L	H	H
L	H	L
L	L	Q ₀
H	X	Z

Notes: H; high level, L; low level, X; irrelevant

Q₀; level of Q before the indicated steady-state input conditions were established

Z; off (high-impedance) state of a three-state output

Block Diagram

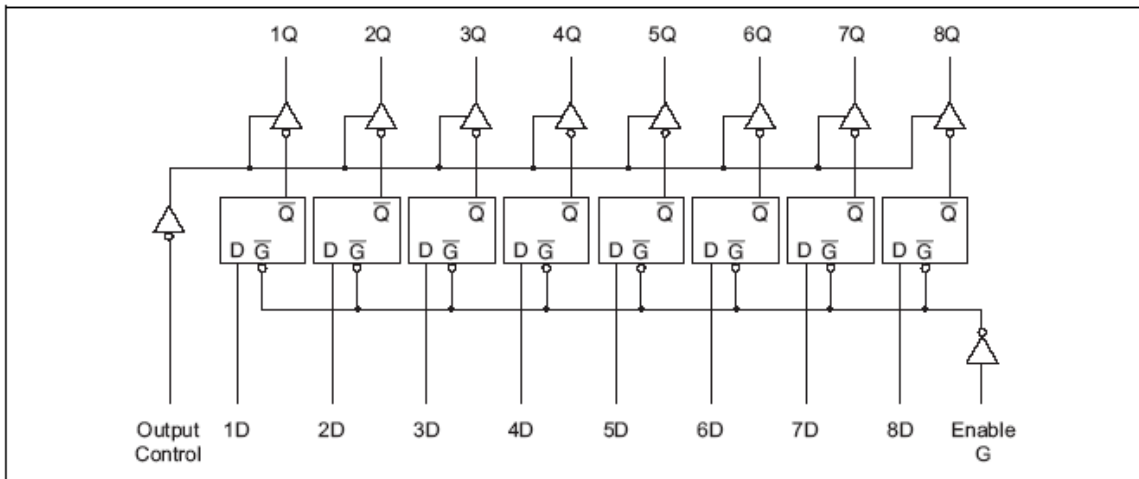

Absolute Maximum Ratings

Item	Symbol	Ratings	Unit
Supply voltage	V _{CC}	7	V
Input voltage	V _{IN}	7	V
Power dissipation	P _T	400	mW
Storage temperature	T _{stg}	-65 to +150	°C

Note: Voltage value, unless otherwise noted, are with respect to network ground terminal.

Recommended Operating Conditions

Item	Symbol	Min	Typ	Max	Unit
Supply voltage	V _{CC}	4.75	5.00	5.25	V
Output voltage	V _{OH}	—	—	5.5	V
Output current	I _{OH}	—	—	-2.6	mA
	I _{OL}	—	—	24	mA
Operating temperature	T _{opr}	-20	25	75	°C
Enable pulse width	"H" Level	15	—	—	ns
	"L" Level	15	—	—	ns
Data setup time	t _{su}	5↓	—	—	ns
Data hold time	t _h	20↓	—	—	ns

Electrical Characteristics

(Ta = -20 to +75 °C)

Item	Symbol	min.	typ.*	max.	Unit	Condition
Input voltage	V _{IH}	2.0	—	—	V	Data inputs G, Output control inputs
	V _{IL}	—	—	0.7 0.8	V	
Output voltage	V _{OH}	2.4	—	—	V	V _{CC} = 4.75 V, V _{IH} = 2 V, V _{IL} = V _{IL max} I _{OH} = -2.6 mA
	V _{OL}	—	—	0.4 0.5	V	I _{OL} = 12 mA I _{OL} = 24 mA V _{CC} = 4.75 V, V _{IH} = 2 V, V _{IL} = V _{IL max}
Output current	I _{OZH}	—	—	20	μA	V _O = 2.7 V V _{CC} = 5.25 V, V _{IH} = 2 V
	I _{OZL}	—	—	-20		V _O = 0.4 V
Input current	I _{IH}	—	—	20	μA	V _{CC} = 5.25 V, V _I = 2.7 V
	I _{IL}	—	—	-0.4	mA	V _{CC} = 5.25 V, V _I = 0.4 V
	I _I	—	—	0.1	mA	V _{CC} = 5.25 V, V _I = 7 V
Short-circuit output current	I _{OS}	-30	—	-130	mA	V _{CC} = 5.25 V
Supply current	I _{CC}	—	24	40	mA	V _{CC} = 5.25 V, V _I = 4.5 V (Output control)
Input clamp voltage	V _{IK}	—	—	-1.5	V	V _{CC} = 4.75 V, I _{IN} = -18 mA

Note: * V_{CC} = 5 V, Ta = 25°C

Switching Characteristics

(V_{CC} = 5 V, Ta = 25°C)

Item	Symbol	Input	Output	min.	typ.	max.	Unit	Condition
Propagation delay time	t _{PLH}	D	Q	—	12	18	ns	C _L = 45 pF, R _L = 667 Ω
	t _{PHL}			—	12	18		
	t _{PLH}	G	Q	—	20	30		
	t _{PHL}			—	18	30		
Output enable time	t _{ZH}	OC	Q	—	15	28		
	t _{ZL}			—	25	36		
Output disable time	t _{HZ}	OC	Q	—	12	20		C _L = 5 pF, R _L = 667 Ω
	t _{LZ}			—	15	25		

Testing Method

Test Circuit

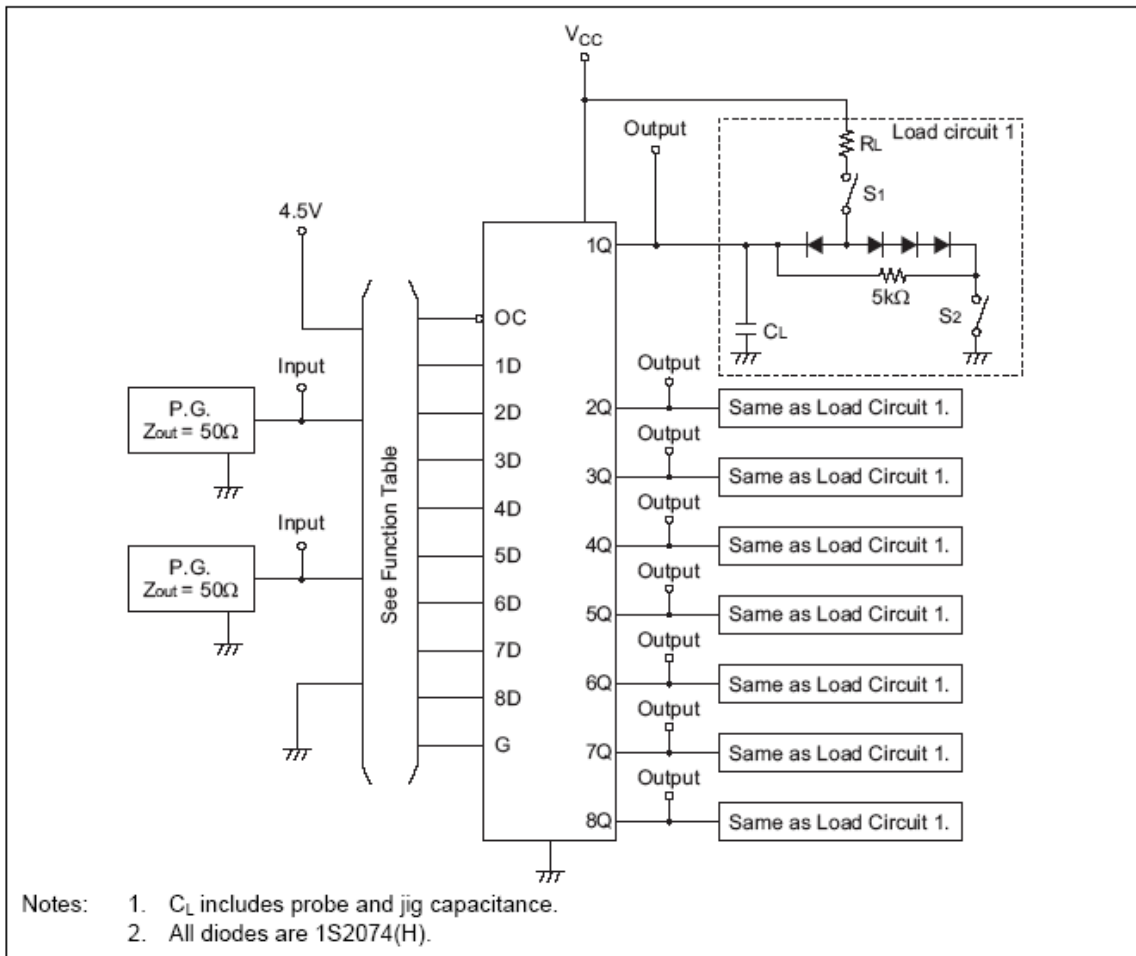

Waveforms 1

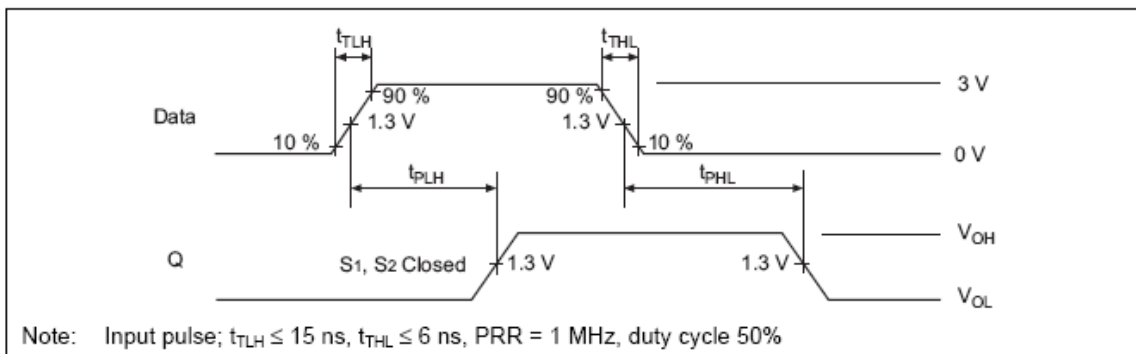

Waveforms 2

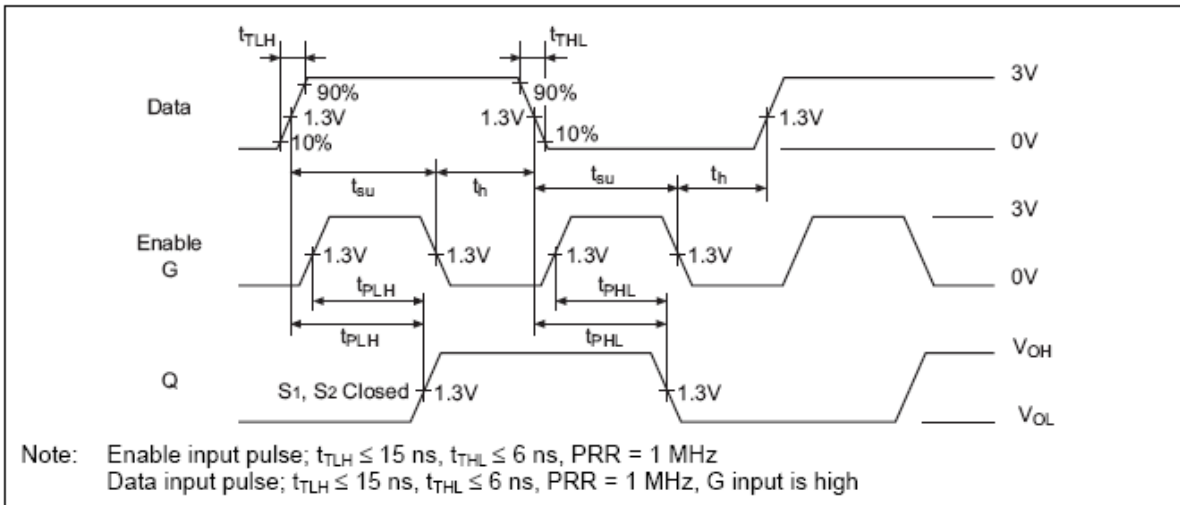

Waveforms 3

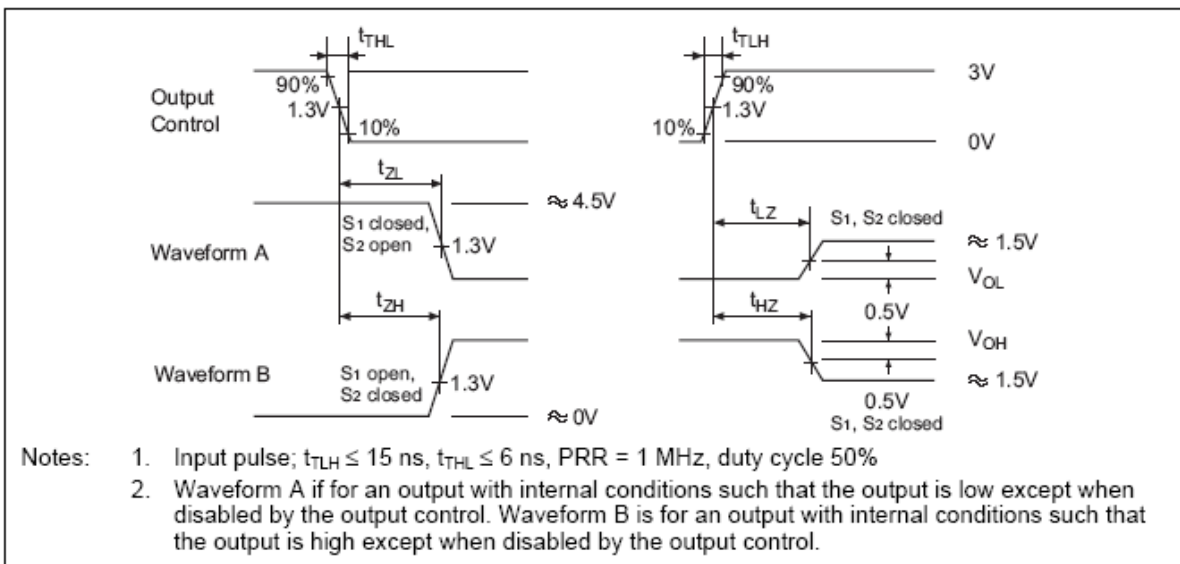

Package Dimensions

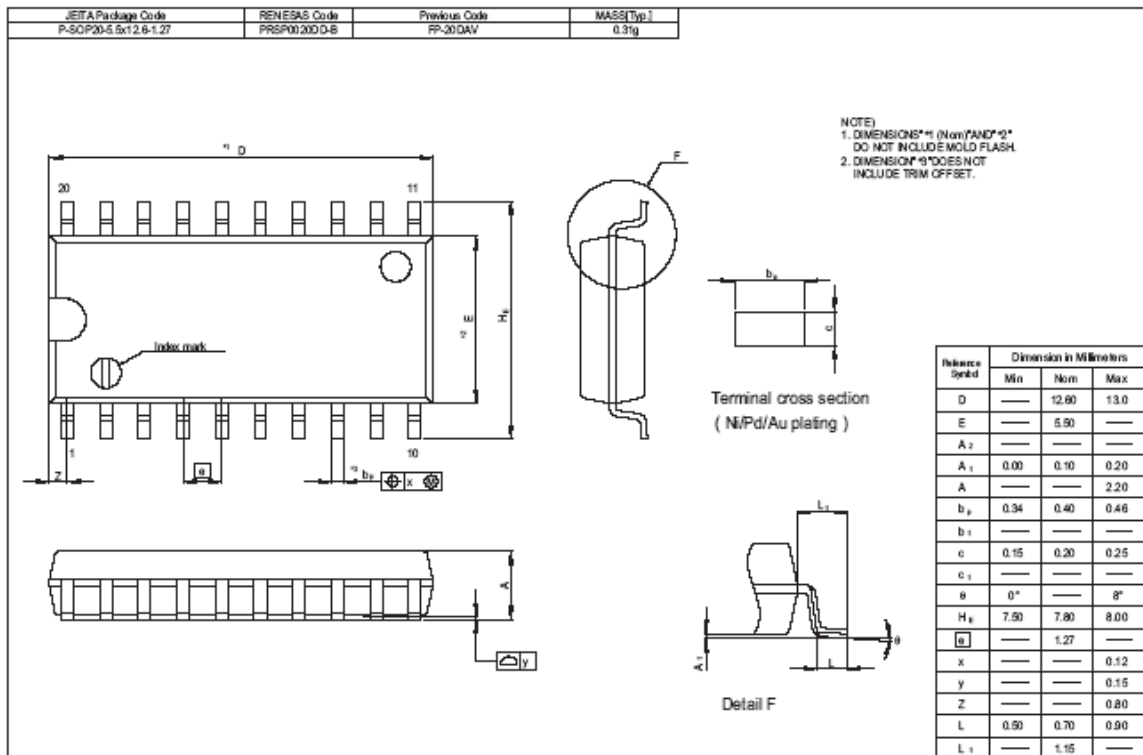
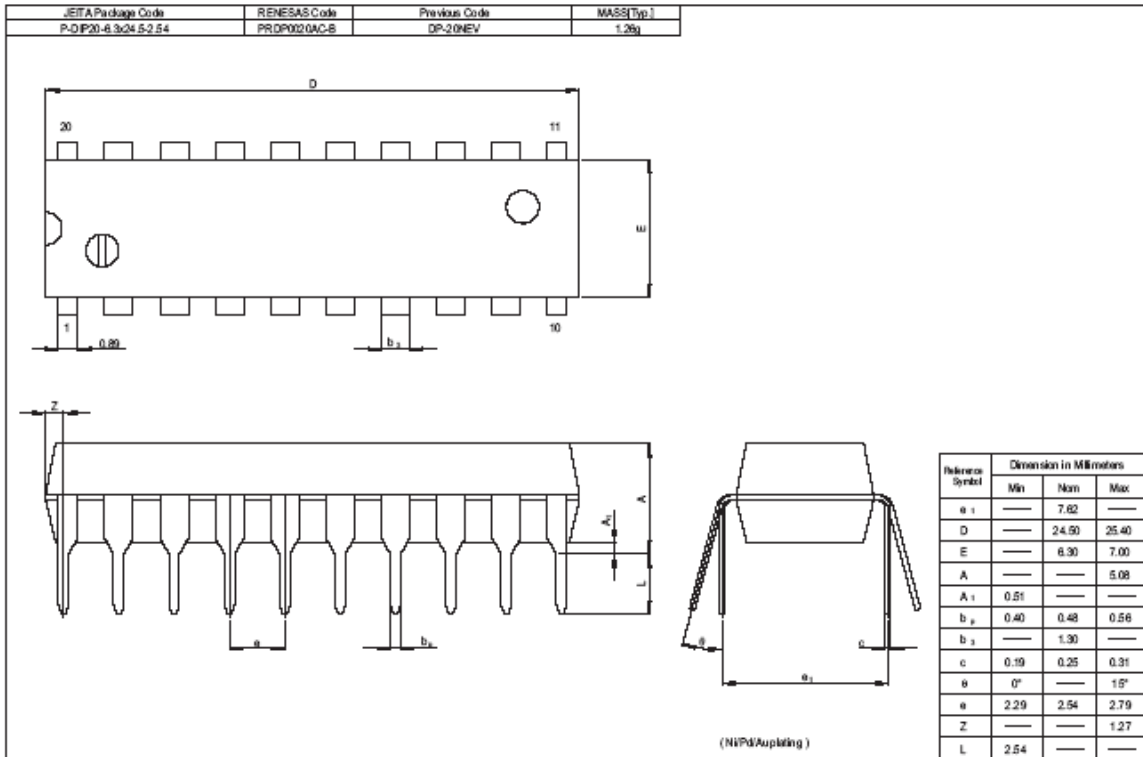

JEITA Package Code	RENESAS Code	Previous Code	MASS(Typ.)
P-SOP20-7.5x12.8-1.27	PRSP02000 C-A	PP-20 DBV	0.52g

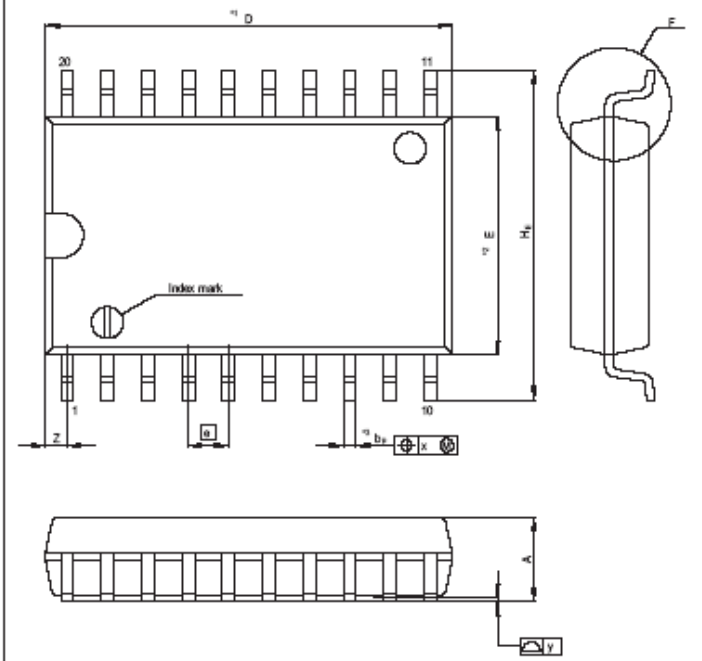

NOTE)
 1. DIMENSIONS**1 (Nom/AND**Z"
 @ DO NOT INCLUDE MOLD FLASH.
 2. DIMENSION**3 DOES NOT
 @ INCLUDE TRIM OFFSET.

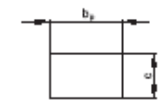

Terminal cross section
 (NiPd/Au plating)

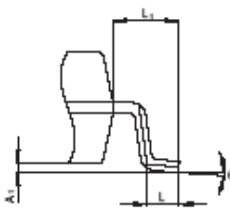

Detail F

Reference Symbol	Dimension in Millimeters		
	Min	Nom	Max
D	—	12.80	13.2
E	—	7.50	—
A ₂	—	—	—
A ₁	0.10	0.20	0.30
A	—	—	2.85
b _p	0.34	0.40	0.46
b ₁	—	—	—
c	0.20	0.25	0.30
c ₁	—	—	—
θ	0°	—	8°
H _e	10.00	10.40	10.65
a	—	1.27	—
x	—	—	0.12
y	—	—	0.15
Z	—	—	0.985
L	0.40	0.70	1.27
L ₁	—	1.45	—