

# **CHAPTER ONE: INTRODUCTION**

## **1.1BACKGROUND**

Construction sites are generally complex and sometimes unsafe. They are complex because of extensive use of sophisticated plants, equipment, modern methods of construction, multidisciplinary and multitasked aspects of its project workforce.

Generally, construction sites are still one of the most dangerous workplaces because of high incidence of accidents, (Teo et al, 2005). The construction industry is characterized by continual changes, bombardment of varying technologies, poor working conditions and need for coordination of different interdependent trades and operations. Due to the hazardous nature of work, safety is a serious problem in the industry, (Tam et al, 2004). Globally, the construction industry has a poor safety record and is disproportionately dangerous compared to other industries, advocated the idea that safety is no luxury but a necessity, (Fung et al, 2005).

The interest in safety awareness among construction companies has greatly increased in the past decade. This increased awareness in safety can be attributed to many factors. As an example, the construction industry has come to recognize the relationship between risk management and return on investment. The ever increasing cost of medical treatment, convalescent care, and the potential for lawsuits all add up to higher insurance premiums, which in turn tend to have a negative impact on a company's profit. In addition, companies with high accident rate are often prohibited from bidding on a certain type of work. It is therefore, in the company's best interest to take whatever means necessary to manage safety on the work site, (Koehn et al, 1995).

Large size companies tend to more effectively deal with the construction management and its applications. Thus, safety management will be more applicable with the large construction companies, which have the managerial ability to deal with such issues. In small to medium companies, safety programs are often very informal and unwritten while in large construction companies such programs are better structured and documented, (Tam et al, 2004).

## **1.2 PROBLEM STATEMENTS**

All over the world, construction is one of the most hazardous industries due to its unique and dangerous nature. Safety has always been a persistent problem in the construction industry. In the United States of America (USA), it was reported that the construction industry accounted for 20% of all occupational fatalities, when they made up only 5% of the USA' work force. In Kuwait, the industry accounts for 42% of all occupational fatalities and in Hong Kong the industry accounts for more than one third of all industrial accidents over the last 10 years. In Singapore, the construction industry takes up 29% of the total number of industrial workers, but the industry accounted for an un-proportionate 40% of the industrial accidents. These studies are among many others that show that the industry has a very poor safety performance record, (Chua and Goh, 2004).

Petersen (1971) has summarized the problem in two points: (1) people are the fundamental reason behind accidents and (2) management is responsible for the prevention of accidents. The management failures represent the real and underlying causes of accidents, (Fang et al, 2004).

However, safety is not a luxury, and may be considered an important function to be used against unnecessary loss of property, injury, or death. Preventing occupational injuries and illness should be a primary concern of all employers. Especially in developing countries, there must be an effort to raise the level of awareness among both employees and employers of the importance of health and safety at work sites.

Emphasis in both developing and developed countries should be placed on training and the utilization of comprehensive safety programs, (Koehn et al, 1995).

Little has been done in this field in Sudan. This research is an attempt to identify the factors affecting the construction safety in Khartoum and to provide a tool for assessing the safety of large construction companies and accordingly improve it.

To reduce the number of accidents, injuries, and fatalities in the workplace, safety should be a top priority. Although the issue of workplace safety has historically been viewed as more of an engineering problem, several researchers (Enshassi, 2003;Hassona, 2005) have increasingly acknowledged that management factors have also played an important role in workplace safety.

### **1.3 SIGNIFICANCE OF THE STUDY**

Accidents in any industry especially in construction tend to be costly in both human and financial terms. As safety is concerned with reducing rates of accidents and controlling or eliminating hazards at the work site, preventing accidents must be the first significant step towards safety improvement. There is a need to increase awareness and to exert pressure on companies for safety. Economical, social and governmental regulations are a few factors responsible for this increased pressure.

Identification and understanding of accident causation is a prerequisite for improving safety.

The accident is in turn invariably caused or permitted directly by the unsafe act of a person and a mechanical or physical hazard (i.e. unsafe condition). To avoid accidents it is required to identify and eliminate unsafe acts and unsafe conditions, which could be achieved by regular assessment of safety on site, employee training and inspection.

This study aims at assessing the safety performance including physical and safety climate of the construction companies in Sudan. It is to the benefit of construction companies to recognize the situation and identify the factors affecting the construction safety. This will help them to take the necessary precautions to control these factors before they occur and be aware of them when they occur during construction, which will lead to improve the overall performance of the company.

This study is to benefit the construction industry in particular and all industries at large. It will help in increasing awareness and in identifying areas of deficiencies in construction safe.

### **1.4 RESEARCH AIM**

This research aims to improving safety performance in Construction Industry in Sudan by assessment the factors which affecting safety performance, and achieve the comprehensive goal to get minimum level of accidents and maximum level of benefits for the labors.

### **1.5 RESEARCH OBJECTIVES**

The main objectives of the study can be summarized in the following points:

1. Assessing the level of the safety practice in construction companies in Sudan.

2. Identify and analyze the most important factors that affect safety performance in construction projects.
3. Make sure that there is a management for health and safety in the engineering companies, whether public or private sector.
4. A culture of insurance and its role in the prevention of the rights of workers and staff.

## **1.6 SCOPE AND LIMITATION**

This research will be limited to the following:

1. Construction contractors point view, where the safety is more likely the responsibility of the construction contractors.
2. Buildings, roads and water sewage works construction companies.
3. Construction companies in Sudan that are qualified and registered in the contractors and classified as first, second or third categories.

## **1.7 RESEARCH HYPOTHESES**

- 1- The existence of strict laws and regulation can reduce the risks in constructions.
- 2- Awareness of the upper management in construction companies to occupational safety and health and makes it as a priority and allocates a budget for the safety will reduce the construction risks.
- 3- A department of occupational health and safety in companies has an effective role in training and educating worker.
- 4- The existence of safety supervisor will create more control and the practice of the controls whenever the work environment is safe.

## **1.8 RESEARCH METHODOLOGY**

The study methodology will include steps, which can be summarized in the following points:

1. Perform a review of literatures relating to the topic of this study. The objective of the review is to identify the factors that affect the safety performance in large construction companies and the methods of safety performance measurement.
2. Collect data via a questionnaire survey to evaluate the factors that affect the safety performance identified in the literature review.
3. Perform analysis of data using appropriate statistical techniques.

4. Report and discuss results and major findings to introduce conclusions and recommendations.

## **1.9 THESIS ORGANIZATION**

This thesis is divided into six chapters, references and four appendices. It includes the following:

- Chapter (1) presents an introduction to the research. It includes the problem statement, the objective, the scope and limitations, the significance and the methodology of the study.
- Chapter (2) presents the literature review and the previous efforts and studies which have been made in the field of safety and the factors affecting the safety performance and of the signs, signals and symbols in the site, and about safety measurement.
- Chapter (3) the current status in Sudan & case study.
- Chapter (4) discusses the research methodology which includes the information about the research design, research population, research location, pilot study, questionnaire design, questionnaire validity, questionnaire reliability, research structure and statistical data analysis.
- Chapter (5) presents and discusses data analysis, statistical methods used, tables and information deduced from statistical analysis and statistical results. The procedures for assessing and improving the safety performance and practice are discussed.
- Chapter (6) summarizes the results and major finding, to present the conclusions and recommendations of this research.

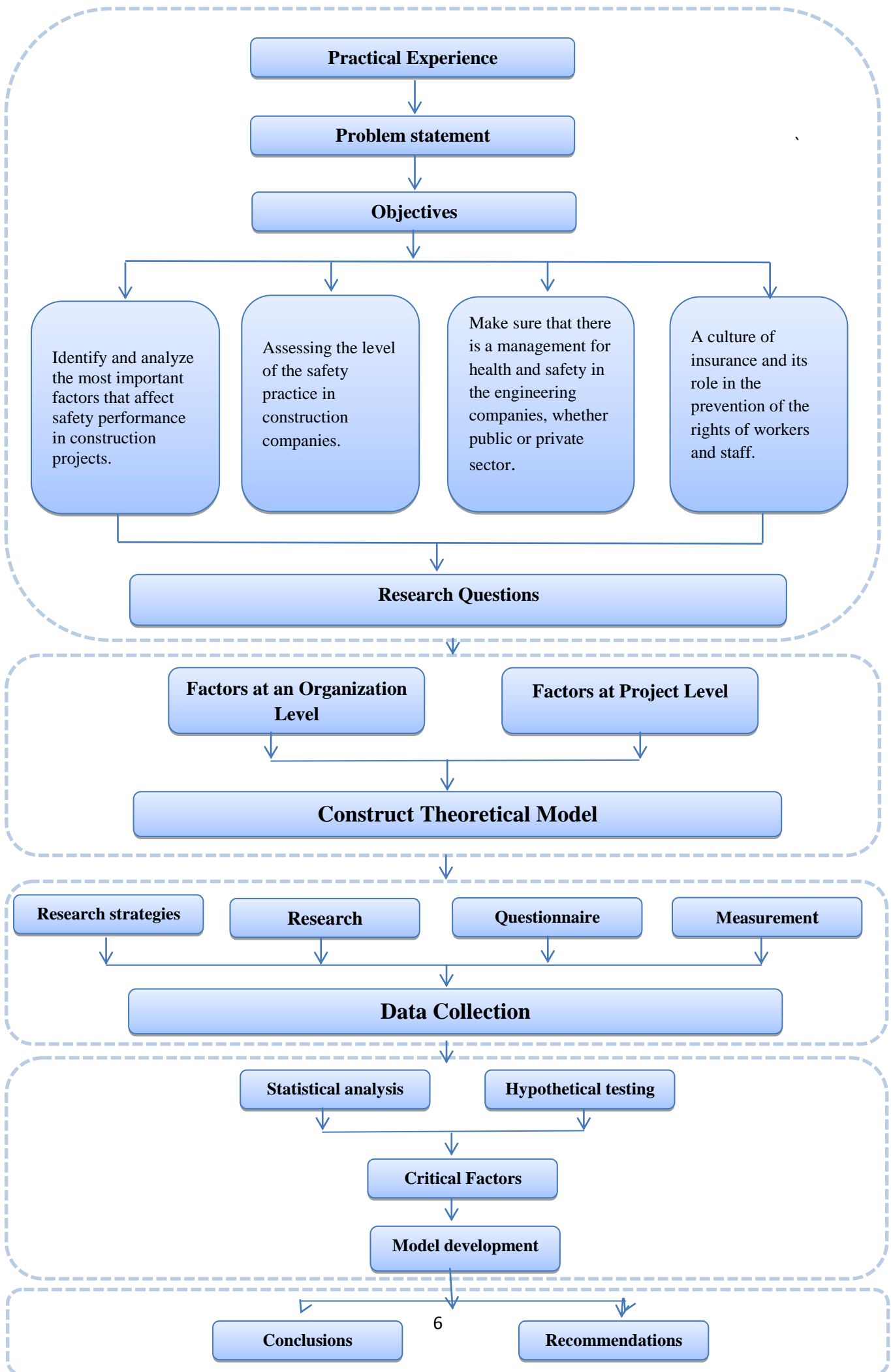

Figure (1-1) Flowchart of Research

## **CHAPTER TWO: LITERATURE REVIEW**

### **2.1 INTRODUCTION**

Safety at work is a complex phenomenon, and the subject of safety attitudes and safety performance in the construction industry is even more so. In China construction industry the risk of a fatality is five times more likely than in a manufacturing based industry, whilst the risk of a major injury is two and a half time higher. Unfortunately, it is not only construction workers who suffer from accidents but, on average, one member of the public, including children, is killed each month, (Sawacha, et al, 1999).

Safety can be considered as a common sense approach to removing agents of injury. The dictionary meaning of the word safety is the conditions of being safe freedom from danger or risks, (Baig, 2001).

Safety assessment is a process used to determine a contractor's compliance with or ability to meet specific safety rules and requirements set by the government safety regulations or by safety and environmental organizations. Safety rules or criteria are needed to accomplish the work with high overall performance. Any deviation from these safety requirements will affect the contractor's overall performance, (Al-Amoudi, 1997).

### **2.2 SAFETY AND HEALTH DEFINES**

The ISO/I.E.C Guide 51 defines safety as "Freedom from unacceptable risk" (2005). Therefore, in order to manage safety it is necessary to understand what leads to unacceptable risk. This understanding can be obtained with identification of important process parameters, their possible deviation from normal conditions, and consequences of these conditions.

To focus on safety requires a comprehensive understanding of the manufacturing process. It is necessary to understand the process in terms of process parameters and process elements, which include the necessary hardware and software that materialize the process. These process parameters and elements need to be understood in term of their relationships and possible interaction, and how deviations from the normal quantities, settings, or behavior can affect the safe operation of the process. To achieve a safe operating plant, it is necessary to design a process where possible

deviations from normal conditions can be kept within specific limits that are dedicated by what is perceived as acceptable risk.

### **2.3 HISTORY OF SAFETY**

As proceed into the Middle Ages, more awareness of the link between the work that people did and the types of injuries and illnesses, which they suffered, was recognized. During this period the first unions began to be organized to try to protect workers from the hazards of the workplace. The only improvement in the 1800s was fire protection because of pressure from insurance companies, (Reese, 2003).

During the first part of the 1900s, workers' compensation laws started appearing and were finally deemed constitutional by the Supreme Court in 1916. Prior to this most employers passed the blame and responsibility to their workers for workplace incidents using what were called "the common laws" which stated:

1. The employer was not responsible when a fellow worker caused your injury due to negligence.
2. The employer was not responsible if the worker was injured due to his/her own negligence.
3. If an employee took a job and knew that it was risky, or knew of the inherent hazards of the work prior to taking the job and was injured, the employer was not responsible.

Under the workers' compensation laws the employers assumed responsibilities for their workplaces' safety and health. They were required to provide and pay for medical care and lost wages due to on-the-job incidents.

It was during this time that mining catastrophes continued to occur and more laws were passed to protect miners. When 2,000 workers or 50 percent of the work force died from silica exposure at Gauley Bridge, West Virginia, the Walsh-Healey Act was passed that required safety and health measures for any employer receiving a government contract. Some companies began to understand their moral responsibility,(Reese, 2003).

When management found itself in the problem, by legislation, of having to pay for injuries on the job, it decided that it would be financially better to stop the injuries from happening. This decision by the industry all over the world gave birth to the organized industrial safety movement. Management concentrated heavily, if not entirely, on correcting the hazardous physical conditions that exist in the work place

in the early years of the safety movement. This showed a significant decline in the death rate (deaths per million man-hours worked) during the first 20 years of the safety movement, (Petersen, 1971).

In December 1970 Congress enacted and President Richard Nixon signed the Williams-Steiger Occupational Safety and Health Act (OSHAct), which became effective on April 28, 1971. It applied to more than 5 million businesses involved in or affecting interstate commerce and 60 million workers, (Hammer, 1985).

Recently, Safety standards and regulations are published by international and national organizations and are accepted by the construction industry. Among these are the Occupational Safety and Health Administration (OSHA) standards for the construction industry, the US Department of Energy safety regulations, and US Army Corps of Engineers safety and health requirement manual, (Kartam, et al, 2000).

## **2.4 Safety via OSHA**

The Occupational Safety and Health Act of 1970 (OSHA) is a comprehensive set of safety and health regulations, inspection procedures, and record keeping requirements. In the United States, the OSHA is the principal authority in charge for regulating occupational and health issues and also for providing safety related training to contractors, (Ahcom, 2004).

OSHA organizes a series of training institute and education centers, which provides training specifically aimed to train safety professionals. In December 2003, OSHA announced the addition of eight more Training Institute Education Centers. They provide a four-day course, which is designed for those in the private sector interested in teaching the 10-hour construction safety and health outreach program to their employees or other interested parties. The experience shows that many contractors are preferring, employees who have experienced 10-hour OSHA training course. The large and small companies also prefer their employees acquainted with OSHA safety training course, (Ahcom, 2004).

## **2.5 IMPORTANCE OF SAFETY**

The advancement in social sciences has promoted a greater awareness of the sanctity of life and the unacceptability of premature death due to accidents. Accidents at construction sites are identified as a major problem throughout the world. According to reports published by the construction industry institute, injuries and fatalities occur

in the construction industry at a rate more than 50% higher than all other industries,(Kartam and Bouz, 1998).

According to Agarwal and Everett (1997), in the United States, the construction industry employs about 5% of the work force, but accounts for 11% of disabling occupational injuries and 18% of all occupational fatalities. These figures have changed in 1998 to be that construction industry employs about 6% of the work force, but accounts for 10% of occupational injuries and 21% of all occupational fatalities. (Everett, 1999).

Research on risk management perceptions and trends in US construction; shows that safety is considered to be one of the highest risk allocations, and is marked at 8.3 on a 10 point scale. By assigning safety the highest importance rating, contractors believe that they have and will continue to have sole responsibility for this risk in the future, (Kartam, et al, 2000).

In their research on important criteria's for contractor selection, Hatush and Skitmore (1997) establish that, health and safety performance of contractors was among the top four important criteria's. Therefore, safety is a very important element in the success of any construction project. It has a major impact on the contractor, owner, workers, and on the environment. In many countries a contractor safety sheet or performance record is considered one of the items that qualify a contractor for a bid. Furthermore, many public agencies include safety standards as part of the construction contract documents, which then become a contractual obligation as well as a legal one, overall, the contractor must be concerned about the safety for the following reasons,(Bu Khamsin, 1999):

- **Humanitarian Concern**

The suffering as a result of an accident both to injured parties and their families cannot be measured in economic terms. The contractor should never disregard this, even when the injured parties have been adequately compensated by insurance.

- **Economic Considerations**

The contractor must realize that even with adequate insurance coverage, accidents will reduce company profits through the increased costs of future insurance premiums.

- **Legal Considerations**

OSHA requires that each employer provides to each of his employees a place of employment that is hazard free.

- **Company Image**

A good safety record is a proven means of increasing worker morale and productivity. This in turn improves the company's public image, and therefore improves the company's bargaining position for negotiating future jobs.

Ineffective accident prevention leads to occupational injuries and illnesses. As a result, workers' compensation insurance costs skyrocket and profits plummet. It is not unusual to see a company with poor injury and illness performance pay three or four times the insurance premium its competitors pay. The costs of injuries and illnesses include medical bills, rehabilitation costs, disability payments and lost-time benefits. These costs, however, are often just the beginning of expense for the employer. The hidden costs of injuries and illnesses may range from four to 10 times the direct costs. Indirect costs resulting from injuries include:

- Administrative costs.
- Failure to meet schedules.
- Loss of production/service capability.
- Overhead costs that continue while work is disrupted.
- Spoiled or damaged product.
- Damaged tools and equipment.
- Loss of efficiency due to breakup of crew.
- Cost of training a replacement worker.
- Lost staff time.

## **2.6 CONSTRUCTION SAFETY IN MIDDLE EAST**

The construction industry in Saudi Arabia employs 15% of the total labor force and accounts for 14% of the total energy consumption in the country (Jannadi and Bu Khamsin, 2002). In Arabic region, construction safety conditions resemble those in developing countries. In the construction industry, the working environment is constantly changing, sites exist for a relatively short time and the activities and inherent risks change daily (Kartam et al, 2000; Jannadi and Bu-Khamsin, 2002). It was found that higher frequencies of construction accidents occurred on projects that were over budget and those that were competitively bid (Kartam et al, 2000). Kartam et al (2000) summarized safety problems in Kuwait as follows: competitive tendering; lack of safety regulations; small size of most construction firms; extensive

use of subcontractors; lack of relevant accident data; extensive use of foreign labor; disorganized labor; high labor turnover; low priority of safety; seasonal employment and weather effect.

Kartam et al (2000) in his research did not mention management in safety problems in Kuwait. Jannadi and Bu-Khamsin (2002) found in questionnaire that the most important three factors influencing safety performance are; (1) management involvement; (2) personal protective equipment; and (3) emergency/disaster planning and preparation. One of the most prevailing problems in Middle East counties is that workers and engineers receive almost no safety training and are mostly uninformed about the company's safety programs or policies (Kartam et al, 2000).

A study of the Egyptian construction industry concluded that safety programs applied by contractors operating in Egypt were less formal and the accident insurance costs were fixed irrespective of the contractor's safety performance, (Hassanein, 2008).

## 2.7 FACTORS AFFECTING SAFETY PERFORMANCE

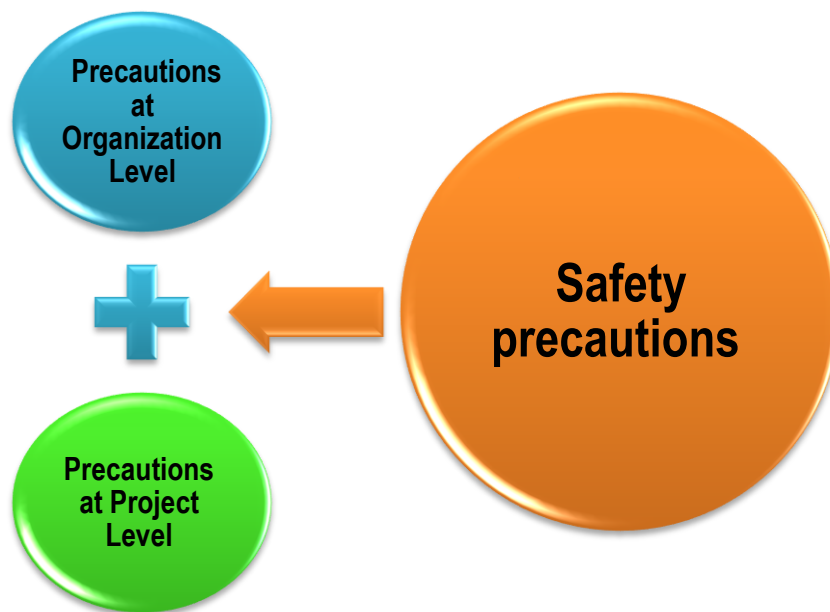

Source: Designed by Researcher

Figure (2-1) Factors affecting safety performance

## **2.7.1 At Organization Level**

### **2.7.1.1 Administrative and Management Commitment**

"Safety is no Accident", "Safety is up to you", "Be Alert -Stay Alive" and "Safety Pays" are few of the common slogans on posters, signs or in magazines when ever men are working in any industry. Frequently, many companies feel that by providing this visual lip service to accident prevention they have viable safety program. Safety must be regarded as a basic component of the management philosophy, just as operating at a profit is, because cost of accidents presents a serious drain of profit. An aggressive company has to examine each of the operations with a keen interest to see not only the work is done in the most efficient manner to ensure greatest potential profit, but also that it is done as safely as possible for the very same reason, (Baig, 2001).

Administrative and management commitment for safety is a very important factor in determining a company's safety performance. Companies which hold their project management accountable for accidents along with productivity, schedules, quality, etc. are the ones which have the best safety records. A critical task in developing a viable safety program is to define management's policy. Most programs fail due to the lack of sincere interest by top management. If top-level management is not genuinely interested in safety procedures, it is most likely that no one else in the company will be. The policy established should contain only what can be supported by intentions and available resources. Safety policy is an illustration of the organization's expression in prioritizing safety in workplace (Torner and Pousette, 2009). Notably, having high characteristics standard policies will harness positive management attitudes, formal conditions, collective values and individual attitudes that will foster better safety performance (Torner and Pousette, 2009). However, on another contention, if safety management systems on sites are complimented with comprehensible policies that are well versed by all personnel on sites, employees will be able to execute any safety system in parallel with their nature of work (Teo and Ling, 2006). Clear cut policies are however inadequate without having a unified international standard to govern how the policies are carried out. The safety program goals should be achievable, but demanding and measurable, so that achievements can be monitored and measured, (Bu-Khamsin, 1999).

The term commitment is really directed at management since it is solely management responsibility to provide a safe and healthy workplace for itsempleeys. When

occupational injuries and illnesses occur they are considered to be failings within the management system. With this said management sets the tone for safety and health within the workplace, (Reese, 2003).

One of the important aspects towards enhancing safety culture is through the safety commitment displayed by the top management of the company. Surveys commissioned by the Health and Safety Executive (HSE) revealed that 75% of all fatal accidents in the civil engineering industries in the United Kingdom are generally caused by ineffective management action taken that large scaled construction companies generally having better safety performance due to the high level of safety support and commitment shown from the top management. Research found that the reduction in accidents would be achieved when top management takes an active interest and is dedicated to safety enhancement as well as maintaining good safety standards, (Teo et al., 2005). Hence, Support and commitment of top management is not sufficient. They must know what it is that they are committed to. That is, what they must do. These obligations cannot be delegated. Support is not enough: action is required. Top management support without action is nothing (Abdel-Razek, 1998). Another one of the important aspects towards enhancing safety culture is incentives factor is one of the determinants that motivate workers to behave in a desired manner to safety regulations on site. It can be viewed a psychological approach that rewards workers for their adhered routine on site (Chan et al., 2010; Haines III et al., 2001). Teo et al (2005) suggested that an incentives program consists of 3 main elements such as monetary, non-monetary, and disciplinary action. A reward system that utilizes money, coupled with non-monetary incentives in the form of holidays, recognitions, promotions can encourage workers to monitor their own safety behavior and performance is capable of improving safety behavior. Workers on site tend to establish their behaviors consistent with the organizations goal, opting for both forms of rewards at the end of the specified compliance of rules. Disciplinary action on the other hand is a form of punishment to the personnel who violates established sets of safety rules and regulations on site. It can take the form of hefty fines and compounds for violators. Combination of reward and punishment can be regarded as a strategy that inculcates safe behaviors among workers on site.

Hinze & Raboud (1988) concluded in their research on safety on large building construction projects, that top management must be supportive of safety in order for safety efforts to be more effective.

Mattila, et al, (1994) conducted a research to study the connections between good management in general and safety. The study was conducted at 16 sites of a construction company. These sites had 15 site managers and 16 other first-line supervisors. The study proved that the most effective supervisors and managers paid more attention to monitoring worker performance and spent less time indicating antecedents than did their less effective counter parts.

The results of the study pinpoint the safety management's role in occupational safety. It is obvious that the supervisor has the opportunity to influence and control behavior, as well as the methods used, and the quality of the work environment. In short, the study shows that effective supervision also means safety. Both research and practical experience indicate that the role of top management is crucially important for achieving results in safety. Unsafe conditions and accidents are usually a sign that something is wrong in the management system itself, (Kartam etal, 2000).

### **2.7.1.2 Safety Inspections**

Safety inspections are one means by which project managers and site supervisors can become acquainted with the nature of the safety conditions on-site. Job site safety inspections by the forepersons are helpful in terms of reducing work injuries, (Hinze and Gambatese 2003).

The use of safety inspections has been shown to have a positive effect on a company's loss control initiative. In fact companies who perform safety inspections have fewer accidents incidents than companies that do not perform inspections. (Reese, 2003).

Good inspections are worth doing. In 1981 a survey of 143 firms in the USA showed those conducting safety inspections averaged nearly 40 percent fewer accidents than firms without an established inspection program, (Al-Amoudi, 1997).

### **2.7.1.3 Safety Meetings**

Regular safety meetings are necessary for communicating safety information to all parties. Safety meetings and safety discussion are a practice done by the safety professional, holding a ten-minute weekly meeting for the crew, discussing the hazards in the work they do and the procedures to be followed to prevent injury or property damage (Al-Amoudi, 1997).

A well planned safety meeting is an excellent morale builder. When an employee is convinced that his employer is concerned about his on the job safety, the employee will conform to the safety rules and perform his work in a safe manner, (Fang et al, 2004).

To make safety meetings more effective, there is a need for more practical and current subject material given by a variety of qualified speakers. They might come from outside, from either the union or the company itself. Smaller meetings for specific crafts also may be appropriate, with more discussion dealing with immediate problems. For crews, which have a variety of work assignments, discussion of the safety aspects of each new assignment might be held before the task, is begun, (Ng et al, 2005).

#### **2.7.1.4 Safety Educating and Training**

It is widely accepted in the construction industry that training plays an important role in worker safety. Worker training typically begins with worker orientation and continues as workers need to become more informed about certain aspects of the work they are doing. These additional training sessions may include topics such as confined space entry, hot work, traffic control, procedures, and a wide assortment of other topics, whether to introduce new information or merely to provide are fresher on a subject, (Hinze and Gambatese, 2003).

The provision of safety training for employees is one important aspect for consideration to improve safety performance. A study on the effect of first aid training on Australian construction workers concluded that training has a positive preventive effect on workers to avoid injury. It has also been found that workplace injuries would be reduced if workers received first aid training, (Teo et al, 2005).

A formal training program helps personnel to carry out various preventive activities effectively. It also helps establish a positive attitude towards safety and integrates safety into the production and quality goals, (Kartam et al, 2000).

The training providing safety skill and information should be supplemented by the techniques of persuasion. Persuasion has an important function. It is most common form is the poster used to indicate bad habits, pinpoint the advantages of safe working, or give detailed information, advice, or instruction on special points, (Al-Amoudi, (1997). Koehn et al, (1995) concluded in their research that in developing

countries, laborers are not trained in safe work practices, and there tends to be a lack of management commitment to safety programs and various safety procedures.

### **2.7.1.5 Project Nature**

The nature of the project is supposed to have strong influence on safety performance. It includes the work environment, complexity of the design and type of owner.

#### **❖ Work environment:**

The aim in site planning and facilities is to produce a working environment that will maximize efficiency and minimize risks. Aspects of site that need to be addressed include access and traffic routes, material and storage handling, site offices and amenities, the construction plant, fabrication workshops, services and facilities, and the site enclosure. Previous research shows that tidy and well planned sites are more likely to provide a high level of safety performance. Workplace hazards may be defined as tangible factors that may pose risks for possible injuries or ailments. Within this definition, hazards do not always result in accidents, but they lurk in work environments, waiting for the right combination of circumstances to come together (Mohamed, 2002).

Mattila, et al. (1994) conducted a study to determine whether there is any connection between the quality of the work environment and occupational safety.

The study was conducted at a construction company. Altogether 16 sites were included. The accidents were analyzed according to the company accident reports.

A safety checklist was used to determine the safety level of the sites. The study proved that the quality of the work environment and the level of safety are directly connected in construction, and the high quality work environment will improve the housekeeping and reduce the accident frequency rates.

#### **❖ Design:**

In the development of a project, a significant role is played initially by the designer of the project and then by the constructor of the project. Construction worker safety has often been regarded the sole responsibility of the construction contractor.

Despite the obvious reasons for placing the primary responsibility on the contractor, the safety performance on a project may well be dictated largely by decisions made by the designer (Hinze and Wiegand, 1992).

Through a questionnaire distributed to designers, it was found that 70% of the respondents did not address construction worker safety and health in their designs.

Experience shows that the safety of construction workers cannot be guaranteed by legislation alone (Kartam, et al. 2000).

Designers can play a strong role in reducing the incidence of injuries and fatalities among construction workers; they should accept this responsibility with a heartfelt commitment to provide in each design a safer workplace for the construction workers. Many construction workers have been severely injured and killed on construction projects, a dear price to pay for the opportunity to work in the construction industry. Designers should address construction worker safety in their designs (Hinze and Wiegand 1992).

Although the involvement of design professionals in construction site safety has been minimal to nonexistent, when they are involved their influence can be significant. It is the design that affects how a particular project and its components will be assembled and how construction tasks are undertaken. When engineers and architects are cognizant of and responsive to the safety consequences of their design decisions, safety improves. This leads to a reduction in injuries and associated costs and a decrease in redesign costs and in operating costs for special procedures and protective equipment (Hinze and Gambatese, 2003).

❖ **Owners:**

Owners have long recognized and honored a moral obligation to provide a safe work environment to minimize injuries. Owners can take measures to achieve better safety performance such as (Improving Construction Safety Performance, 1982):

- Provide safety and health guidelines that the contractor must follow
- Require the use of permit systems for potentially hazardous activities.
- Require the contractor to designate a responsible supervisor to coordinate safety on the site.
- Discuss safety at owner-contractor meetings.
- Conduct safety audits during construction.
- Require prompt reporting and full investigation of accidents.

Hinze and Gambatese (2003) concluded in their research to identify factors that significantly influence the safety performance of specialty contractors that safer worker performances were realized among those firms reporting that large percentage of their projects were with private owners.

### **2.7.1.6 Role of Government and Engineering Societies**

The government should play an important role in safety management in the construction industry. This is by enacting specific labor legislation, issuing laws and rules to protect labor, conducting a periodically work sites inspections through a competent safety engineers and subjecting the contractors to a citation or fine for unsafe conditions or hazards existing on a projects. The engineering societies have played an important role in developing and enforcing safety standards. Engineering ethics codes and related educational activities are another way in which the organizations help to eliminate dangerous situation, indirectly, in this case, by contributing to the development of safety consciousness among engineers (Fang et al, 2004). Obviously, an important objective of engineers is to minimize all types of technological hazards. Engineering societies contribute to the achievement of this goal in several ways: (1) By helping to extend engineering knowledge; (2) by formulating and promulgating safety standards; (3) by making engineers more safety conscious; and (4) by supporting engineers who take strong positions on behalf of worker and public safety, (Fang et al, 2004).

The safety legislation and policies have a great impact upon the safety level of a construction worksite. Legislation forms a framework in which health and safety is regulated and controlled. All project managers have to follow the rules and regulations duly and punishments to be meted out to those who flout them.

Legislation and its enforcement do affect construction safety lo a considerable extent. As such, safety legislation has to be taken seriously when planning job activities and setting up company policies, (Teo et al, 2005).

Labor unions in industrial countries are powerful and can pressure contractors' to provide safe working conditions and safety equipment to protect their work forces' rights and health. Hence, workers are not aware of their rights to safe working conditions. In developing countries, labor groups feel alone with no organization to defend them and they have to accept the company's policies and rules, (Kartam etal, 2000).

Koehn et al, (1995) concluded in their research that in developing countries laws to protect laborers may not be strictly enforced. Also, contractors and their employees tend to ignore basic safety rules and regulations. Government regulations of save work conditions to meet safety needs mainly means the contractor management thinks

of the safety regulations as guidelines to follow to help him develop safety policies and procedures that meet specific needs.

### **2.7.1.7 Economic Investment**

Economic investment in safety has considerable influence on safety performance.

Many projects generate little profit for the companies and in some cases huge losses are incurred. Thus there is often an inadequate economic investment in safety on most projects. Safety is often considered an issue supported by everyone.

Unfortunately, when it comes to spending money on safety, many people do not feel it is vital to the success of the project. The main concern of a contractor is how to save money and reduce costs. Safety is usually considered a secondary priority in the company's plans. Safety is considered a waste of money by most contractors since they may be unaware of the effectiveness of safety prevention programs in reducing costs and increasing productivity (Kartam, et al. 2000).

The cost of establishing and administering a construction safety and health program is somewhat less tangible, but can be estimated with reasonable accuracy. Data collected from a significant sample of contractors working at various construction sites in 1980 indicate that the cost of administering a construction safety and health program usually account to about 2.5% of direct labor costs. These costs include salaries for safety, medical and clerical personnel, safety meetings, inspection of tools and equipment, orientation sessions, site inspections, personal protective equipment, health programs such as respirator-fit tests and miscellaneous supplies and equipment, (Improving construction safety performance, 1982).

A popular assumption holds that increased investment in safety produces improved safety performance. Most of the current literature suggests a relationship between safety investment and accident loss. This relationship shows that accident loss will be reduced when investment in safety is increased. Zero investment in safety usually results in maximum accident losses while initial investments have the greatest impact, which results in large decrease in accident losses, (Al-Amoudi 1997).

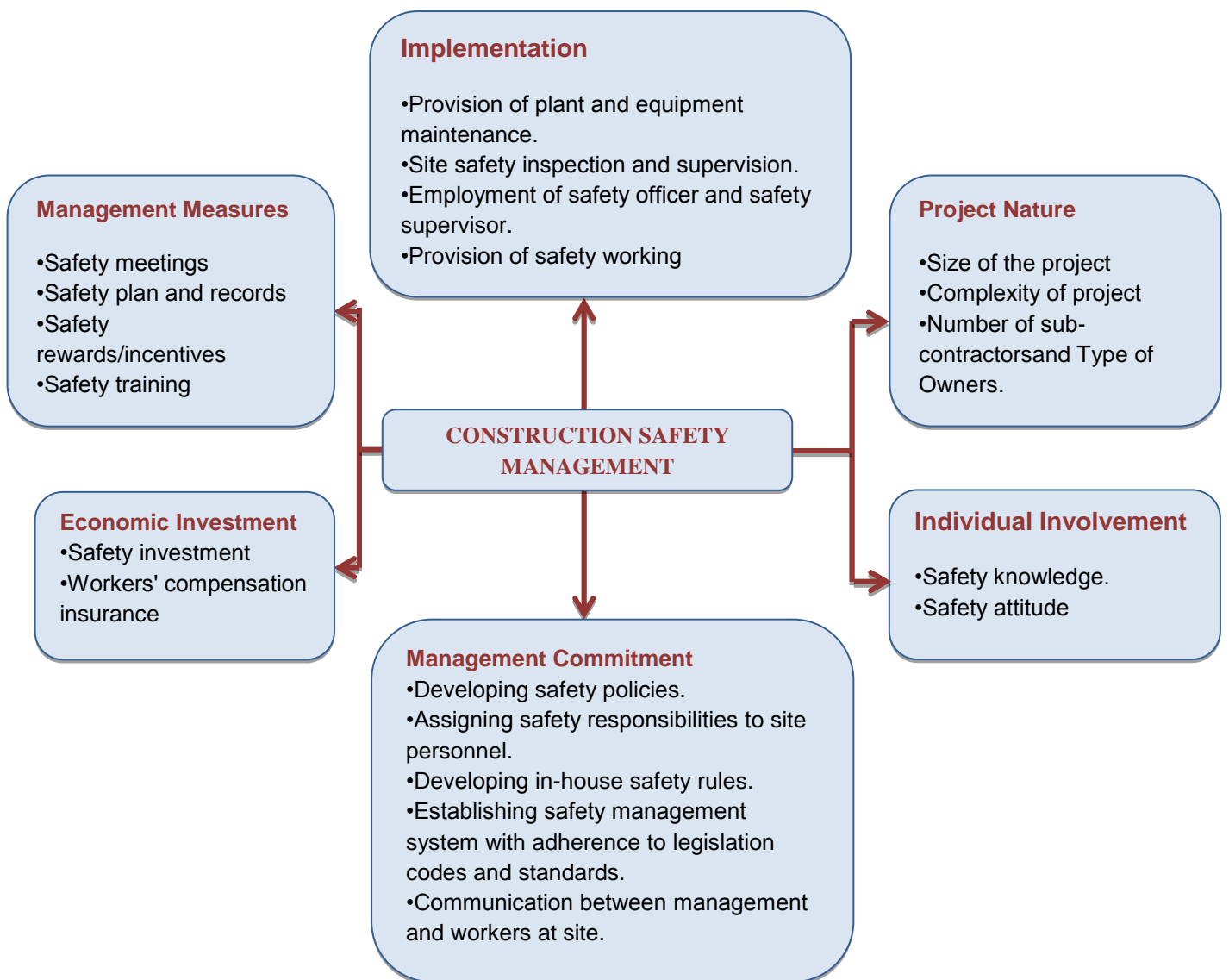

Source: Designed by Researcher

Figure (2-2) Construction Safety Management Framework

## 2.7.2 At Project level

### 2.7.2.1 Public protection

The site should be fenced in to keep out unauthorized persons, children in particular, and to protect the public from site hazards. The type of fencing will depend on the location of the site, but in populated areas it should be at least 2 m high and without gaps or holes. Overhead protection will be necessary if tower crane loads pass over public thoroughfares.

When work finishes, the following factors must be checked to insure public protection:

- Site entrances are secured.
- Perimeter fencing is intact and functional.
- Flooded areas, excavations and openings are covered or protected by barriers.
- All site plant and remaining vehicles are immobilized.
- Access to scaffolding is removed or blocked.
- All piled and stacked materials are safe.

### 2.7.2.2 Fall prevention:

Falls are a major cause of injury and death in workplaces. The vast majority of these accidents are falls from heights even though the height may be no more than two or three meters. Most of these injuries and deaths have happened because fall protection was either missing or not used.

Workers are required to provide workers with fall-protection training if the workers will be exposed to fall hazards. A worker at risk of falling certain distances must be protected by guardrails or, if guardrails are not practical, by a travel restraint system, fall-restricting system, fall-arrest system, or safety net. Personal fall protection equipment consists of the components shown in the following illustration. This equipment can be used for travel restraint or fall arrest.

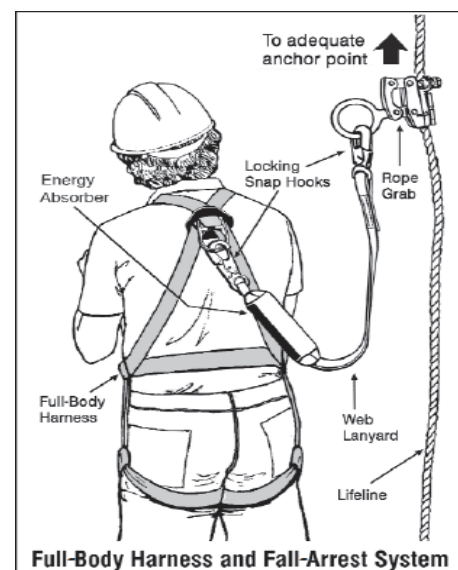

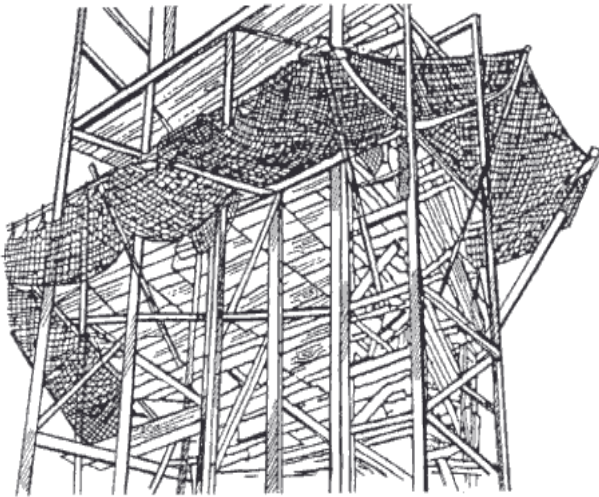

**Safety nets**

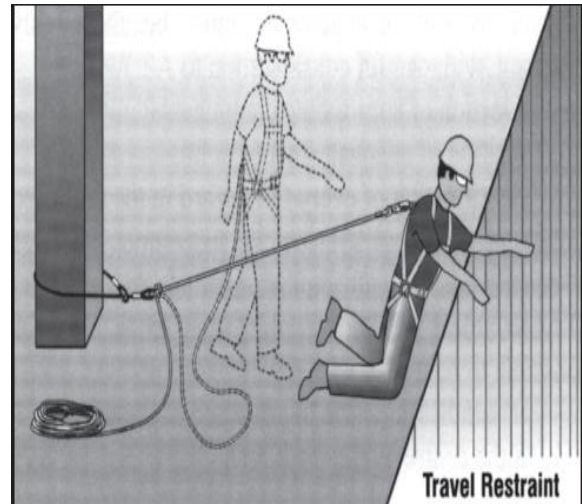

**Picture (2-1)**

Safety, health and welfare on construction sites: A training manual, Geneva, International Labour Office, 1995

### **2.7.2.3 Site tidiness and safe access**

As a worker you can make a major contribution to safe working conditions on site by attention to tidiness. There are many accidents due to tripping, slipping or falling over materials and equipment which have been left lying around, and stepping on nails which have been left projecting from timber.

Be sure you take the following steps:

- Clean up as you go do not leave rubbish and scrap for the next person to clear.
- Keep gangways, working platforms and stairways clear of equipment and materials not in immediate use.
- Clean up spilled oil and grease.
- Deposit waste material at a recognized disposal point.
- Remove or hammer down any nails you see projecting from timber (picture (2-2)).
- Artificial lighting at places where work continues or workers pass after dark.

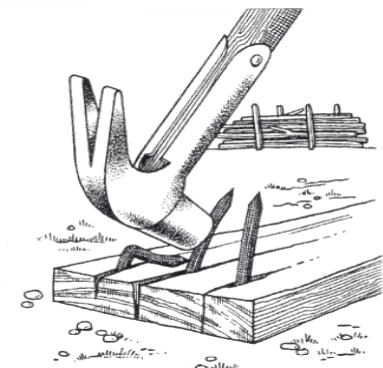

**Picture (2-2)**

Safety, health and welfare on construction sites: A training manual, Geneva, International Labour Office, 1995

### **❖ Disposal of Hazardous Materials and Waste**

In Saudi Arabia, the contractors are required to dispose of hazarded waste according to Saudi government regulations. In this respect, the contractors must provide proof that the hazardous waste has been properly disposed of a licensed hazardous waste

disposal facility. Overall, the contractor must give full attention to the following when dealing with hazardous materials and waste, (Bu- Khamsin,1999):

- Hazard identification plan.
- Waste management plan.
- Disposal site.



**Picture (2-3)**

U.S. Department of Labor/ Occupational Safety and Health Administration/ OSHA 3151-12R 2003

#### **2.7.2.4 Scaffolds**

Scaffolds consist of easily assembled frameworks of steel or timber on which working platforms may be placed. Scaffolds may be fixed or mobile. Working platforms on scaffolds consist of good-quality timber boards laid so that they are level and both ends are properly supported; intervening supports will be necessary if the timber is liable to sag due to loading by people or materials, (Yassin, 2004).

Platforms should never be less than 600 mm in width if used for access and working or 800 mm if used also for materials. Where there is a risk of falling more than 2 m, the outer edge and ends of a working platform should be protected by a rigid guard rail, secured to the standards at a height of between 0.91 and 1.15 m above the platform. To prevent materials falling off the platform, a toe board rising at least 150 mm above the platform should be provided along its outer edge, again secured to the standards, (Heng, 2006).

Scaffolders who erect and dismantle scaffolds should be given specific training and experience to ensure their own safety and the safety of others who may use the scaffolds. Scaffolds are often provided by one, perhaps the main, contractor for use by all contractors. In this situation, trades people may modify or displace parts of scaffolds to make their own job easier, without restoring the scaffold afterwards or

realizing the hazard they have created. It is important that the arrangements for coordination of health and safety across the site deal effectively with the action of one trade on the safety of another, (Hislop, 1999).

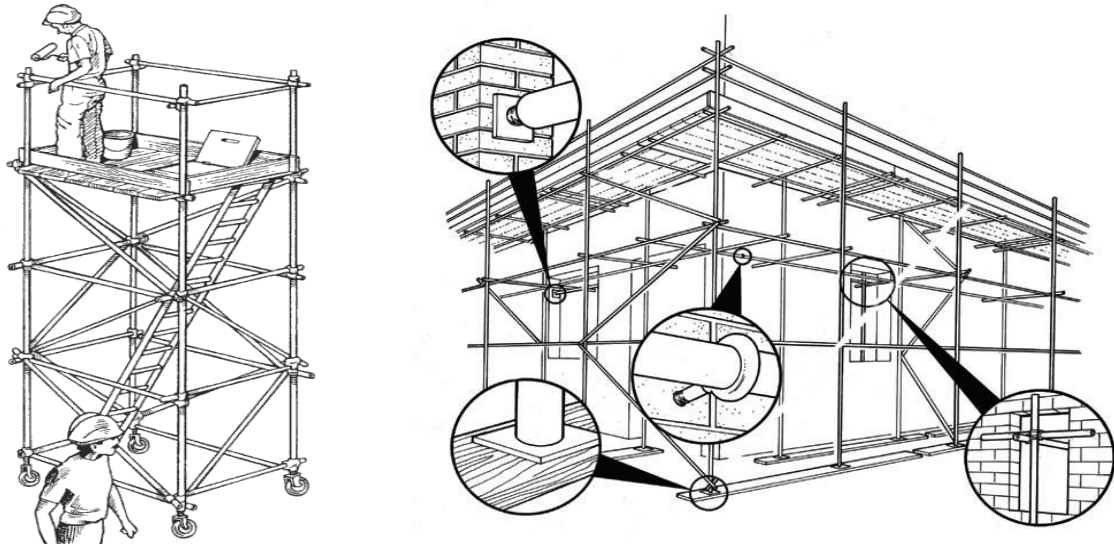

**Picture (2-3)**

Safety, health and welfare on construction sites: A training manual, Geneva, International Labour Office, 1995

### 2.7.2.5 Ladders and step ladders

More than half of ladder accidents are caused by the ladder slipping at the base or at the top. So make sure that you stand the foot of your ladder on a firm and level base. Never wedge one side of the ladder up if the ground is uneven. If possible, level the ground or bury the foot of the ladder. If the ground is soft, put down a board. Never support the ladder by carrying its total weight on the bottom rung – only the stiles or side members are meant for this.



**Picture (2-5)**

Safety, health and welfare on construction sites: A training manual, Geneva, International Labour Office, 1995

- Make sure that your ladder is long enough for the job.
- Avoid carrying tools or materials in your hand while you are climbing ladders.
- Clean your footwear before climbing
- Always inspect your ladder before you use it.
- Remove damaged ladders from use and make sure that they are properly repaired. If they cannot be properly repaired, they must be destroyed.
- Make sure your ladder is lashed or footed before you climb it

### 2.7.2.6 Crane and Lifting Equipment

All contractor crane operators require a valid license in Saudi Arabia. In addition, the cranes shall have valid safety inspection stickers, and manufacture safe working load (SWL) stickers. Before beginning any crane operation, the supervisor and the operator should complete the pre-operation checklist. Also, a lift plan showing the essential crane operation requirements must be included. One competent person must be in charge of the lift with responsibilities of explaining in details, the duties of all involved in the lift before the actual lift commence (Bu-Khamsin, 1999).

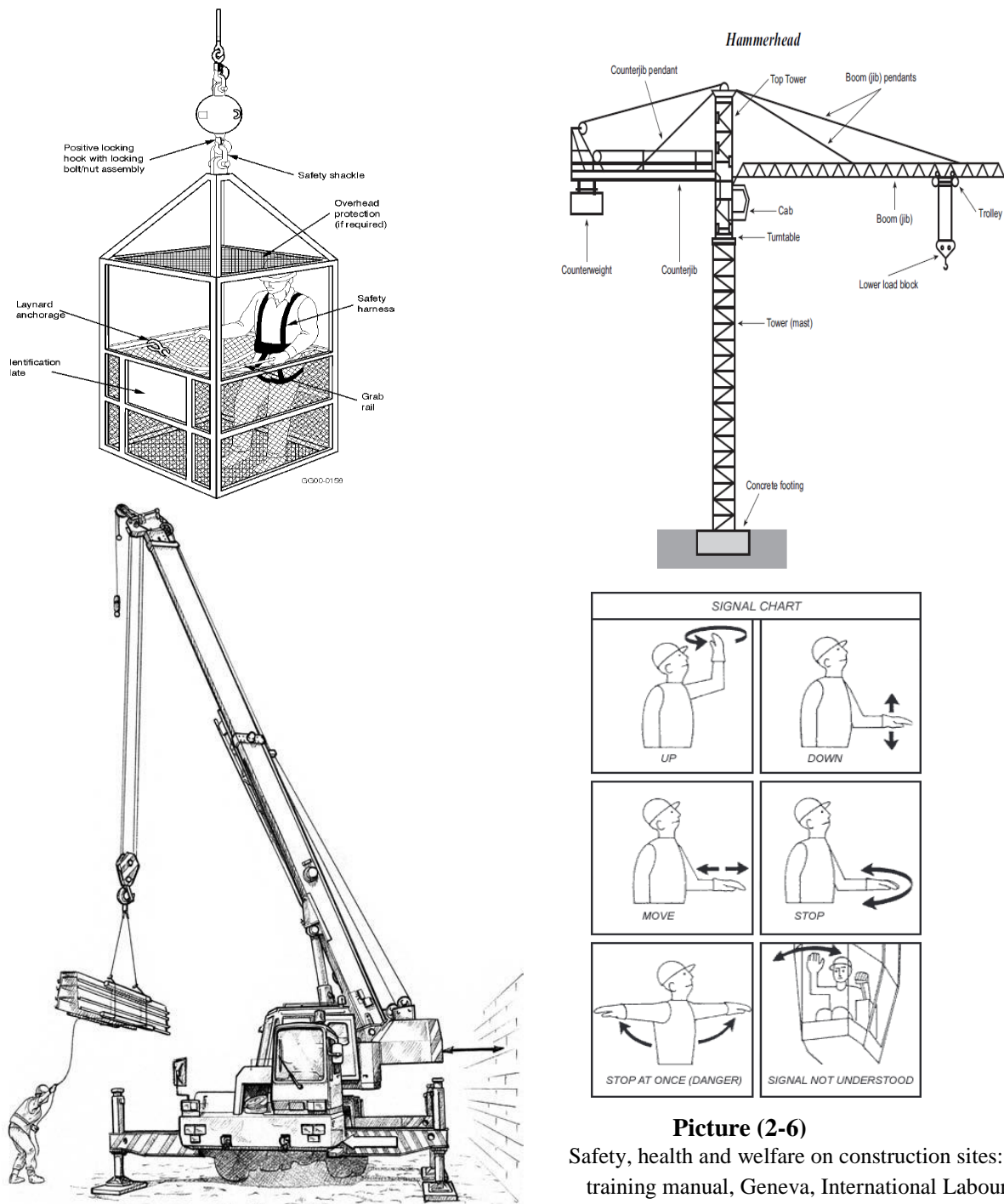

**Picture (2-6)**  
 Safety, health and welfare on construction sites: A training manual, Geneva, International Labour Office, 1995

### **2.7.2.7 Site traffic and vehicles**

The contractor must employ only qualified personal a drivers of vehicles and provide them regular refresher driving courses and training .it in a government law that each person driving a vehicle must possess a valid driver's license. It is the responsibilities of the drivers to ensure that his vehicle is safe to operate. In order to prevent serious injuries and fatalities resulting from accidents, the contractor must consider the following, (Hammer, 1985):

- Passenger seating a seat belt.
- Vehicle condition.

The underlying cause of most site traffic accidents is the failure to plan a safe system of work and to train workers how to follow it. However, the common immediate causes are one or a combination of the following factors: bad driving techniques which include reversing blind, carelessness or ignorance of special hazards, e.g. work near overhead power lines or excavations, carrying unauthorized passengers, poor maintenance of vehicles, overloading or bad loading, site congestion, poor traffic layout and lack of proper roadways combined with uneven ground and debris.

- Keep your vehicle tidy and the cab free from tools and material which might obstruct the controls.
- Keep to speed limits.
- Do not carry unauthorized passengers.
- Do not drive across a slope.
- Use the steps if fitted, otherwise use the wheel rims to dismount from the cab; do not jump.
- Never mount, or dismount from, a moving vehicle.

### **2.7.2.8 Excavation and Trenching**

Usually the first job to be done on the site after site surveys and laying out of the site once the contract has been is groundwork for the foundations. In the case of domestic housing, the footings are unlikely to require excavations greater than half a meter and may be dug by hand, (Occupational Safety and Health Administration).

For buildings, the foundations may need to be several meters below ground level.

This will require the digging of trenches in which work will have to carry out to lay or erect the foundations. Trenches deeper than 1 m are likely to be dug using machines

such as excavators. Excavations are also dug to permit lying of cables and pipes. Contractors often use special-purpose excavators capable of digging deep but narrow excavations. If workers have to enter these excavations, the hazards are essentially the same as those encountered in excavations for foundation (Eckenfelder, 1997).

Work in excavations deeper than 1 m needs especially careful planning and supervision. The hazard is the risk of being struck by earth and debris as the ground collapses along the side of the excavation. Ground is notoriously unpredictable; what looks firm can be caused to slip by rain, frost or vibration from other construction activities nearby. What looks like firm, stiff clay dries out and cracks when exposed to the air or will soften and slip after rain. A cubic meter of earth weighs more than 1.8 ton; a worker struck by only a small fall of ground risks broken limbs, crushed internal organs and suffocation. Because of the vital importance to safety of selecting a suitable method of support for the sides of the excavation, before work starts, the ground should be surveyed by a person experienced in safe excavation work to establish the type and condition of the ground, especially the presence of water, (Xie et al, 1999).

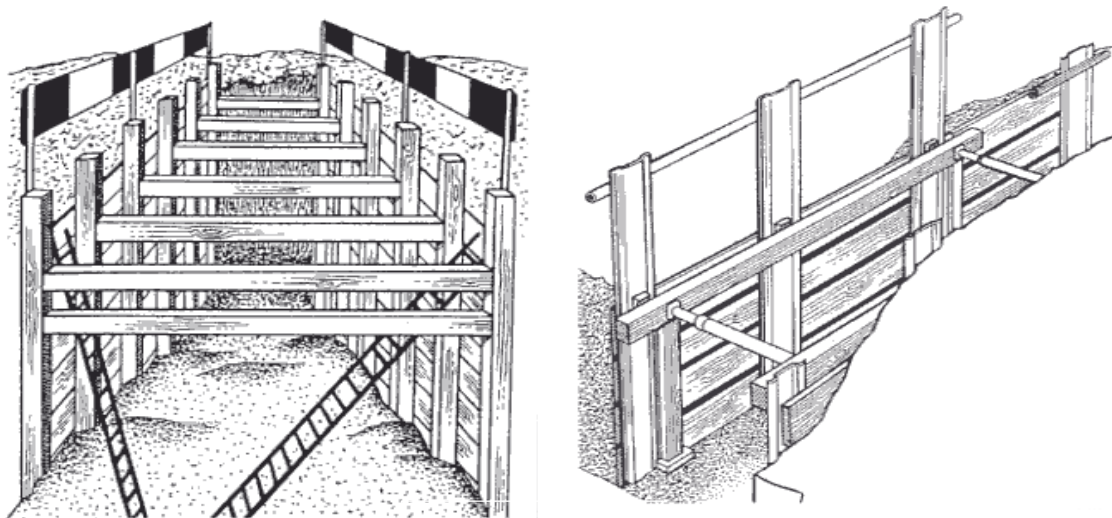

**Picture (2-7)**

Safety, health and welfare on construction sites: A training manual, Geneva, International Labour Office, 1995

### **2.7.2.9 Fire Prevention, Emergency Planning and Preparations**

Prior to construction start-up, the contractors must take into account the potential hazards that can be encountered on the construction site by making provisions for the fooling: protection of machinery and equipment, storage of flammable and combustible material, housekeeping, staff training and end-of-shift checks. Each contractor has contractual obligation to provide and maintain adequate, easily

accessible fire extinguishers on the job site. There are three types of the extinguishers, which are normally found in construction site: water, carbon dioxide and dry chemical types. Contractors personal should be aware of the fighting equipment's available on the site and be familiar with its use, (Hislop, 1999).

Effective emergency planning requires that workers be familiar with emergency procedures before a crisis it is the responsibilities of the contractors to ensure that all workers are familiar with the proper response to fire and other serious emergencies.

The potential for emergency exits at all construction sites and facilities and their associated costs can be devastating in terms of worker casualties, business interruption, loss of capital of investment, etc. These events cannot be avoided but the contractors can reduce of the frequency of the occurrence and severity of damage with effective preparation and planning. This can be accomplished by developing emergency response plans that address immediate concerns within the contractor's operation. An emergency is an abnormal incident posing a threat to the safety of workers, the environment or property at a facilities or site. The emergency can be brought under control using the resource and procedures for emergency response in place for the facilities or site, (Hislop, 1991).

### **2.7.2.10 Electricity**

Every year workers digging on construction sites suffer severe burns when they accidentally hit live buried electrical cables. Always treat buried cables as live. Before you begin excavating, inquire of the electricity authority, the local authority or the site owner if they have any plans of the layout of cables in the area. Even if plans exist, remember that some cables may not be marked on the plan or may not be exactly where the plan shows, for cables rarely follow an exact straight line.

- Never work ahead of the side supports in a trench even when you are erecting shoring.
- Appearances can be deceptive. The shallowness of an excavation or the solid appearances of the ground are not necessarily an indication of safety.
- Deep trenches look dangerous, but most fatal accidents occur in trenches less than 2.5 m deep.
- Always wear a safety helmet when you work in an excavation.

Look around for traffic signs, street lights and substations which are usually supplied by buried cables. Use a cable locator if you have one – remember that if cables are

close together the locator may not be able to tell them apart. Some types of cable cannot be traced by locators. Once you have found the cable, notify your supervisor and fellow workers. The position of the cable should be marked with chalk, crayon or paint or, if the ground is too soft for this, with wooden pegs. Never use sharp spikes. Once the approximate position of a buried cable is known, use hand tools to expose it. Use spades and shovels rather than forks or pick-axes. Keep a careful watch for evidence of cables during digging work. Power tools should not be used within half a meter of a cable.

### 2.7.2.11 Dangerous substances

You should make sure that any substances that you use which may cause any kind of hazard are used with the proper precautions and with proper reference to the regulations that apply to them if any exist.

1. We considered all harmful materials, e.g. asbestos, lead, solvents, pants etc. and identified them properly.
2. The risks to everyone who might be exposed to these substances have been assessed.
3. Precautions been identified and put in place, e.g. is protective equipment provided and used; the workers and others who are not protected kept away from exposure.

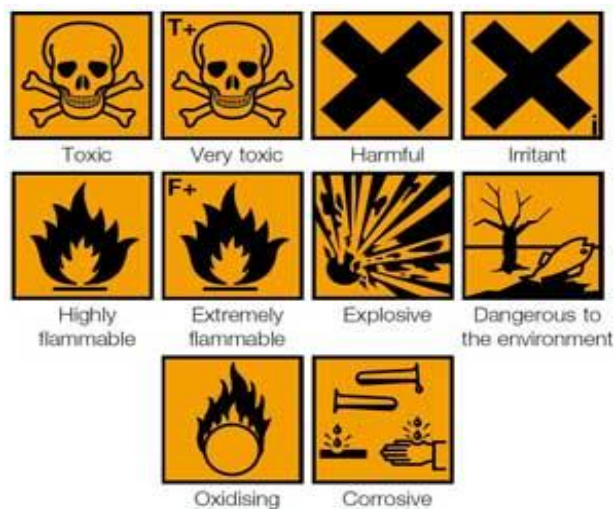

**Picture (2-8)**

<http://www.cleaning-team.co.uk/blog/2010/03/new-international-hazardous-substances-symbols>

### 2.7.2.12 Manual handling

The handling of raw materials and building components is an integral part of the construction process. Manual handling of loads and materials is still very common. Many workers carry out heavy lifting and carrying operations during much of the working day. Next to falls, manual handling is the most common cause of construction accidents.

The proper mechanical handling of materials can ensure that work flows smoothly, and helps to avoid delays and damage. In manual materials handling too, one can apply techniques and ideas which increase efficiency and are not expensive. These “low-cost” solutions most frequently arise from local needs and experience.

#### ❖ Lifting and carrying

Almost one-quarter of work injuries occur during manual handling, most of which are strains to the hands, legs, feet and back. Much construction work involves heavy manual labour and workers not in good physical condition tire easily and are more susceptible to injury. You should know your physical capabilities and only tackle jobs you can reasonably handle. It is important, too, to have been trained in the right techniques of lifting and carrying. Look after your own welfare by:

- putting the load on wheels if you can instead of carrying it;
- using mechanical handling equipment if you have been trained to use it;
- Wearing the right equipment for the job such as safety boots,
- checking the weight of the load before lifting;
- Not lifting loads higher than is necessary;
- Removing or securing loose objects on the load;
- Making sure that there is a clear walkway to your destination and a safe stacking place.

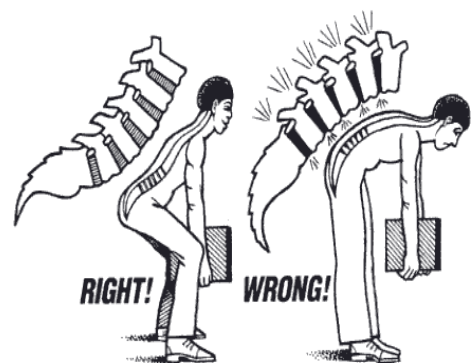

**Picture (2-9)**

Safety, health and welfare on construction sites: A training manual, Geneva, International Labour Office, 1995

### 2.7.2.13 Welfare Facilities

The contractor must be provided adequate welfare facilities for his workers usages, prior to starting the construction activities. The contractors must meet the following requirements in order to prevent construction site accidents. (Permana, 2007):

- Smoking area
- First aid facilities (Medical Facilities)
- Food and drinking water
- Toilets
- Ambulance

#### ❖ Medical Facilities

Medical facilities include the availability of the medical advice; adequate facilities for first aid treatment and conducting periodically medical testing. Workplace hazards often can be eliminated by redesigning the site. Where it is not feasible to eliminate such hazards, workers must control them to prevent unsafe and unhealthful exposure. Workers must eliminate or control the hazard in a timely manner once it becomes apparent. Specifically, as part of the program, workers should establish procedures to correct or control present or potential hazards in a timely manner. One of these procedures is establishing a medical program that includes first aid onsite as well as nearby physician and emergency medical care to reduce the risk of any injury or illness that occurs, (OSHA 2202, 2002).

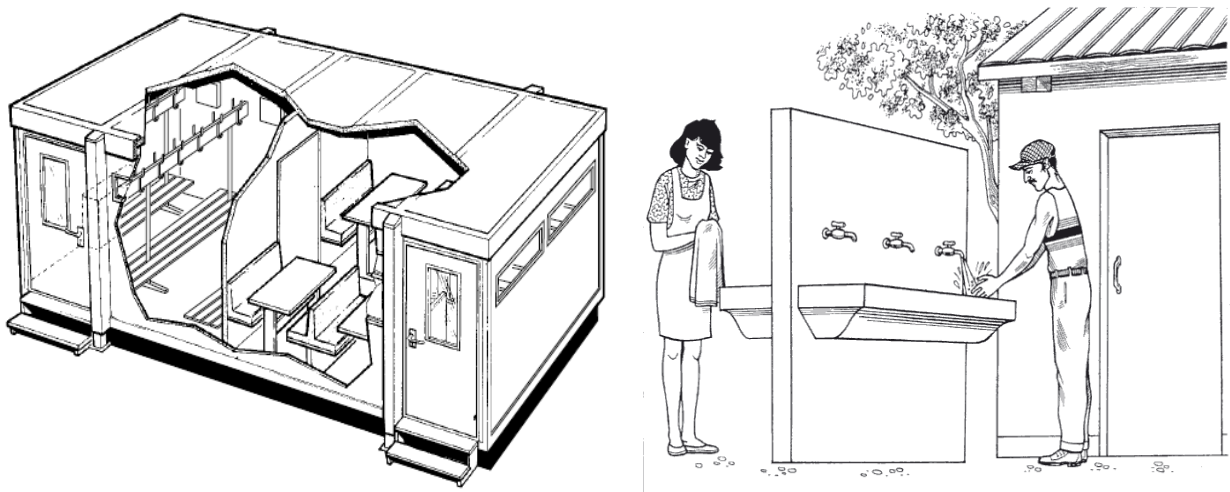

**Picture (2-10)**

Safety, health and welfare on construction sites: A training manual, Geneva, International Labour Office, 1995

### **2.7.2.14 Noise**

- Breaks and others plant or machinery fitted with silencers.
- Barriers erected to reduce the spread of noise.
- Work sequenced to minimize the number of people exposed to noise.
- Others not involved in the work kept away.
- Suitable hearing protection provided and worn in noisy areas.

### **2.7.2.15 Personal Protective Equipment (PPE)**

Providing appropriate equipment's to avoid the probabilities of accidents to workers, certain things that must be considered and these includes the implementation of PPE which may be uncomfortable to wear or may be an obstruction, strict inspection on proper implementation of PPE; and high cost of providing PPE. There are two categories of PPE. The first must be used safety helmet; safety shoes; and suitable working clothing. In addition, the second category depending kind of work, like eye protection, protective gloves, ear protectors and safety belt, (Jannadi, 2001).



**Picture (2-11)**

U.S. Department of Labor/ Occupational Safety and Health Administration/ OSHA 3151-12R 2003

### **2.7.2.16 Signs, Signals and Barricades**

The contractors should establish a system of signaling for all operations in which signal are required to prevent danger, as far as practicable a uniform signaling system must be adapted for all constructions. The code of signals should be posted up at suitable places and also made available in the form of a handbook. In order to avoid danger, the contractor should take adequate steps to ensure that workers are familiar with all signals that they should know, (Tam et al, 2003).

### **2.7.2.17 Historic, Human and Psychological Climate**

The historic factor mainly indicates the safety related experiences of people on site, as human experiences influence their safe or unsafe actions and their involvement in safety on site. Human behavior is very important, and it is difficult to control. Unlike engineering solutions, in which numbers are plugged into various formulae to solve specific problems, handling people requires situational leadership. Hazards cannot be solved and eliminated just through engineering control. They also need to be recognized by employees who will minimize their effects. However, human behavior cannot be programmed like a machine, (Jannadi, 1995).

The psychological climate has been shown to directly influence the safety performance of individual workers. This climate includes the workers' relationship with or the attitude toward fellow crew members, the supervisor, and the employing firm. The safer workers worked in smaller crews and they also had a more cordial or friendly relationship among themselves. Safer workers also had supervisors who openly showed them respect and gratitude by incorporating or considering their suggestions and by praising them for work well done. The safer workers were those who had positive feelings about their employer. For instance, they felt that they would choose the same department as a place of employment even if other options existed. In fact, the safer workers stated that they would probably work at their present job until retirement. They also felt that the employer cared for their welfare.

The work place was also shown to influence safety performance. Workers who are faced with more frequent job deadlines and who get involved in competition with fellow workers had more injuries, (Hinze and Raboud, 1988).

In a research carried out by Jannadi (1995), impact of human relations on the safety of construction workers, it was found that an effective use of human relations would improve safety programs and make safe behavior a habit for workers. It was also found that safety performance of each worker was very much related to his attitude towards his fellow employees and employer. One more conclusion from the study was that management's attitude towards worker's welfare can also play a major role in developing safe behavior among the workers and thus a safe performance in the workplace. This study showed that competition among workers, fatigue, and working under pressure had a tremendous impact on safety.

Workers who face deadlines which are almost impossible to meet, compete with other crew members, and work overtime have more injuries. The workers are emotionally vulnerable and preoccupied with their problems since most of them are working in unsecured conditions, (Kartam et al, 2000).

Koehn et al. (1995) concluded in their research that in developing countries, workers are generally unskilled or semi skilled, poorly paid, temporarily employed, low productivity rates, and often migrate in a group from one place to another in search of work.

## **2.8 PREVIOUS STUDIES**

### **2.8.1 Levitt and Parker (1976)**

Levitt and Parker (1976) studied the role of top management in construction firms in reducing construction injuries. They established that: companies whose top managers talked about safety when they visited job sites had lower **Experience Modification Rating (EMR's)** than companies in which safety was not mentioned during these events. They also found that companies with formal orientation programs had lower EMR's compared to companies with no orientation programs. He also talked about another 5 factors like incentives and awards. Levitt and Parker (1976) recommended that safer contractors recognize the link between safety and productivity, and that they charge accident costs to the specific projects where they occur. The same study also showed that safest companies were those that had accident records broken down by projects and that used this information in salaries and promotions.

### **2.8.2 Hinze and Raboud (1988)**

Study by (Hinze and Raboud 1988) on large building construction projects in Canada showed that larger firms generally had better safety records, which supports the previous study by Hinze and Harrison. The study by Hinze and Raboud concluded that lower injury rates were noted on projects that employed safety officers; those which conducted job site safety inspections; and those which included safety in coordination meetings. The authors also found that company level practices influenced safety performance. Safety performance was better on projects that employed full time safety directors and those which exhibited top management support for safety. The results also showed that safer performances were on projects

that used sophisticated schedules and those which included the owner or his representative in coordination meetings.

### **2.8.3 Sawacha et al., (1999)**

Sawacha et al., (1999) Identified factors that influencing safety performance on construction sites under organization safety policy were: Management talks on safety, Provision of safety booklets, Provision of safety equipment, providing safety environment, appointing a trained safety representative on site. Sawacha recommended that appointing a trained safety representative contributed directly to excellent safety performances.

### **2.8.4 Jaselskis et al., (1996)**

Jaselskis et al., (1996) assert that to achieve better construction safety performance at the project level, the H&S factors/elements that are important for achieving better safety performance are: increased project manager experience level, more supportive upper management attitude towards safety, reduced project team turnover, increased time devoted to safety representative, more formal meetings with supervisors and specialty contractors, more informal safety meetings with supervisors, a greater number of informal site safety meetings with supervisors, a greater number of informal site safety inspections, reduced craft worker penalties, and increased budget allocation to safety awards.

### **2.8.5 Jannadai et al., (2002)**

Jannadai et al., (2002) revealed that management involvement, personal protective equipment, emergency planning and preparation and other nineteen factors were considered to be extremely important safety factors in influencing safety performance in Saudi Arabia as they reveal the greatest impact. Jannadai recommended that safety rules and regulations need to be defined, documented and enforced. Hence the need for an administrative body for occupational safety and health implementation is evident; however, the integrity and effectiveness of such an organization is a major concern in relation to the existing adversarial business environment in the construction industry , which also need to be addressed.

### 2.8.6 Teo, et al (2005)

Teo, et al identified how project managers may increase the safety levels of construction sites. He showed that there were fourteen (14) factors where these factors were divided into four (4) main categories which were: Policy aspect, Process aspect, Personnel aspect, Incentive aspect. Teo recommended that a major need of the industry is to develop the attitude of project owners towards an active safety management implementation; for the same, awareness programs need to be developed and implemented. It would also be appropriate to arrange formal and informal education and training in safety in the form of graduate education and career development programs.

**Table 2-1 Summary of Researches Relating to Safety (Jannadi. 2001)**

Year	Authors	Summary Research	Key factors associated with safety success
1976	Levitt and Parker	Related to top management role in reducing construction accidents.	<ul style="list-style-type: none"> <li>-Company manager's awareness of safety problems.</li> <li>- Evaluation of superintendents based on safety performance.</li> <li>-Top managers pointedly talking about safety when they visited jobs and <u>experienced modification rates(EMR)</u> lower than companies in which this was not mentioned during interviews.</li> <li>- Companies that conducted formal safety orientation for all new hires had average EMR lower than companies that had no formal orientation for newly hired workers.</li> <li>- Incentives based on lost-time accidents awarded to workers, foremen, and superintendents for accident-free work had no effect on safety, according to research findings.</li> <li>- Crews were found to perform work quicker, better and more safely when managers insisted on detailed work planning (including materials, equipment, man power, and safety requirements) prior to the start of the job.</li> </ul>
1978	Hinze	Identified safety impact of new worker and turnover rates.	<ul style="list-style-type: none"> <li>- Superintendents whose crews had fewer injuries where those having larger percentage of workers transferring with them from one job to the next</li> <li>- Safety increases when companies retain their employees for more than one year, and there are additional safety benefits when employees are kept for even longer periods of time (five years in this study).</li> </ul>
1987	Hinze and Pannullo	Found that increased job controlled to better safety Performance.	<ul style="list-style-type: none"> <li>- General trends suggested more top-management visits per week lowered the injury index.</li> <li>- Injuries tended to be lower in those firms engaging in projects in close proximity to the home office.</li> <li>- Safety companies employed the same workers for a longer duration.</li> </ul>

			<ul style="list-style-type: none"> <li>- Safety performance improved when more workers visited the home office regularly.</li> </ul>
1978	Hinze and Parker	Investigated superintendent characteristics associated with improved safety performance.	<ul style="list-style-type: none"> <li>- Increased job-related pressure on superintendents led to increase injuries.</li> <li>- Superintendents in strong support of job competition and those who only moderate supports of competition.</li> <li>- Superintendents who were under pressure to complete the job from the home office had higher injury frequencies.</li> </ul>
1979	Hinze and Francine	Investigated supervisor worker relationships and how they affect injury rates.	<ul style="list-style-type: none"> <li>- Supervisors who are more flexible in dealing with subordinate conflicts have better safety records compared to their more rigid counterparts.</li> <li>- Safety performance is worse when foremen have full firing authority</li> </ul>
1981	Hinze and Harrison	Identified safety program practices in large companies associated with reduced injury frequency rates	<ul style="list-style-type: none"> <li>- The corporate safety director hired the field safety representative.</li> <li>- Field safety directors trained their subordinate workers.</li> <li>- The safety director reported to the president or vice president of the company.</li> <li>- New workers received formalized safety orientation.</li> <li>- Safety awards were given to workers.</li> <li>- Safety awards were given to foremen.</li> </ul>
1982	Samelson And Levitt	Identified owner's guidelines for selecting safe contractors.	<ul style="list-style-type: none"> <li>- Owners who involve themselves actively in selecting and monitoring safety performance of contractors have significantly lower accident rates on their construction.</li> <li>- Several owner strategies were found to have a significant impact on contractor safety: use of short-term worker permits to regulate hazardous operations; stressing safety during the pre-bid site visit; incorporating detailed job specific safety requirements in specifications and periodic inspections; maintenance for safety records; setting ambitious goals for contractor safety and rewarding successful achievement of those goals; considering safety as a criteria in presenting contractors for bid lists; providing safety orientation and training materials for contractor's labor and supervision for hazardous operations unique to the particular project; and developing in-house owner construction safety personnel with the expertise to carry out their tasks.</li> <li>- Actions such as requiring contractors to delegate safety to onsite personnel, examination of safety at job site meetings, and investigation of accidents were initiated by both safe and average owners.</li> <li>- Placement of considerable emphasis on selection of safe contractors by the owner is necessary for fewer monitoring and control actions.</li> </ul>
1988	Hinze and Reboud	Identified appropriate means of achieving or maintaining acceptable safety performance on large projects.	<ul style="list-style-type: none"> <li>- Employed a full-time company safety officer.</li> <li>- Strong top-management support for safety.</li> <li>- Safety meetings were conducted for supervisors.</li> <li>- Supervisor safety performance was monitored.</li> <li>- Specific job site safety tours were conducted.</li> <li>- Safety issues were included in regular held coordination meetings.</li> <li>- Lower incident rates occurred on projects that employed sophisticated scheduling techniques.</li> <li>- Better safety results occurred when the owner or owner's representative was included in coordination meetings.</li> <li>- Job pressures (particularly those imposed by budgetary constraints) were found to adversely affect safety performance.</li> </ul>

1988	Hinze and Figone	Investigated specialty contractor safety as influenced by general contractors on small and medium-sized projects.	<ul style="list-style-type: none"> <li>-Superintendents who felt less project pressure had safer projects.</li> <li>-Projects on or ahead of schedule were safer.</li> <li>-Companies that emphasis other goals in addition to profits had safer projects than companies only seeking to maximize profit.</li> <li>-Companies that negotiated a majority of their prime contracts had safer projects.</li> <li>- Several variables related to job coordination affected safety positively, smaller projects; projects with fewer specialty contractors; companies that negotiated a majority of their subcontracts; and companies that use the same specialty contractors.</li> <li>- Two variables related to company safety emphasis result in safer projects; companies whose home office monitors project safety, and concern by top management.</li> <li>- Two variables related to superintendents' concern for workers result in safer project; superintendents who show concern for workers and superintendent who provide new worker orientation.</li> <li>-Two variables related to job cleanliness result in safer projects; good housekeeping, and daily specialty contractor safety inspections.</li> </ul>
1988	Hinze and Figone	Investigated specialty contractor safety as influenced by general contractors on large projects	<ul style="list-style-type: none"> <li>- Significant factors correlated with general contractor injury rates; conducting special safety meetings for field supervisors, and employing full-time safety professionals.</li> <li>-Significant factors correlated with general contractor safety performance: specialty contractor was involved in project meetings with the owner; general contractor reported directly to the home office rather than the district office; general contractor reviewed specialty contractor safety programs or required them to follow project-wide safety programs: project schedules were prepared by superintendents or site scheduling department: and general contractor required the specialty contractor to hold 'toolbox" safety meetings.</li> </ul>
1988	Hinze and Figone	Investigated specialty contractor safety as influenced by general	<ul style="list-style-type: none"> <li>- Factors that tended to show a relationship to improved general contractor safety performance: the general contractor was not experiencing excessive schedule pressure; general contractors were located farther from their home office: and the general contractor investigated all specialty contractor accidents.</li> </ul>
1993	Liska, et al.	Identified zero accident techniques Contractors on large projects.	<ul style="list-style-type: none"> <li>-Safety project/pre-task planning included safety goals, safety person/personnel, hiring employees, safety policies and procedures, fire protection program, accountability/responsibility, and safety budget concerns.</li> <li>- Safety training and orientation required.</li> <li>- Safety incentives provided.</li> <li>- Alcohol-and substance-abuse program in place.</li> <li>-Accident and near-miss investigation conducted.</li> <li>-Record keeping and follow-up undertaken.</li> <li>-Safety meetings held.</li> <li>-Personal protective equipment employed.</li> </ul>

An extensive literature review has been conducted to identify the factors which affect the safety performance of construction projects. Table 2-2 shows the summary of pervious researches to identify the factors that affect the safety performance in construction projects.

**Table 2-2 Summary of Researches to Identifying the Factors that Affect Safety Performance**

Year	Author	Summary of research	Factors affecting safety performance
1999	Sawacha, et al.	Identify factors influencing safety performance on construction sites	<ul style="list-style-type: none"> <li>- Management talks on safety.</li> <li>-Provision of safety booklets</li> <li>-Provision of safety equipment</li> <li>-Providing safety environment</li> <li>-Appointing a trained safety representative on site.</li> </ul>
2001	Jannadi, et al	Identify Safety factors considered by industrial contractors in Saudi Arabia	<ul style="list-style-type: none"> <li>-Site planning and housekeeping</li> <li>-Welfare facilities</li> <li>-Emergency /disaster planning and preparations</li> <li>Signs, signals and barricades</li> <li>-Handling, storage and use of material</li> <li>-Welding and cutting</li> <li>-Concrete and concrete framework</li> <li>-Crane and lifting equipment</li> <li>-Chemical handling</li> <li>-Electrical equipments</li> <li>-Handling, transportation and disposal of hazardous materials and waste</li> <li>-Personal protective equipment</li> <li>-Fire prevention</li> <li>-Transportation</li> <li>-Excavation, trenching, shorting</li> <li>-Scaffolding and ladders</li> <li>-Hand and power tools</li> <li>-Mechanical equipment</li> <li>-Ionization radiation</li> <li>-Management involvement</li> </ul>
2004	<i>Fang, et al</i>	Discussing an empirical research on workplace safetymanagement performance on construction sites in China	<p><b>Foremen related factors</b></p> <ul style="list-style-type: none"> <li>- Frequency of a crew's receiving safety inspection.</li> <li>-Frequency of a foreman's presence in safety meeting.</li> <li>-Frequency of a foreman's reporting safety related matters to manager.</li> <li>-Frequency of a foreman's announcing safety related matters to workers.</li> <li>-Frequency of a foreman's correcting workers unsafe actions.</li> </ul> <p><b>Worker related factors</b></p> <ul style="list-style-type: none"> <li>-Frequency of a worker's smoking on the site.</li> <li>-Frequency of a worker's breaking safety regulations.</li> <li>-Hours of safety education per year a worker receives.</li> <li>-Frequency of a worker's partners reminding him of personal safety.</li> </ul> <p><b>Crew related factors</b></p> <ul style="list-style-type: none"> <li>-Frequency of a crew s receiving notices of hazard removal.</li> <li>-Frequency of a crew s breaking safety regulations.</li> <li>-Frequency of a crew's suffering safety penalty.</li> </ul> <p><b>Manger related factors</b></p> <ul style="list-style-type: none"> <li>-Frequency of a project manager s presence in safety meeting.</li> <li>-Frequency of a project manager's hearing safety</li> </ul>

			<p>reports.</p> <ul style="list-style-type: none"> <li>-Frequency of a project manager's discussing safety matters with subcontractors.</li> </ul> <p><b>Safety training related factors</b></p> <ul style="list-style-type: none"> <li>-Days of safety education per year a safety officer receives.</li> <li>-Hours of safety education per year a foreman receives.</li> <li>-Frequency of a foreman's reminding new workers of safety regulations.</li> <li>-Ratio of workers whose occupational experience is less than 1 year to total workers on site.</li> </ul>
2005	Tam, et al	Identifying elements of poor construction safety management in China	<ul style="list-style-type: none"> <li>-Poor safety awareness of top management.</li> <li>-Lack of training.</li> <li>-Poor safety awareness of project managers.</li> <li>-Reluctance to input resources to safety.</li> <li>-Reckless operations.</li> </ul>
2005	Ng, et al.	Evaluating safety performance of construction contractors	<p><b>At an organizational level</b></p> <ul style="list-style-type: none"> <li>-Implementation of safety management system in accordance with legislation.</li> <li>-Compliance with occupational safety and health legislation, codes and standards.</li> <li>-Definition of safety responsibility.</li> <li>-Development of safety policy.</li> </ul> <p><b>At project level</b></p> <ul style="list-style-type: none"> <li>-Provision of safe working environment.</li> <li>-Development of emergency plan and procedures.</li> <li>-Development of safety committee.</li> <li>-Definition of safety responsibility to all site personnel.</li> </ul>
2005	Fung, et al.	Investigating the safety culture in Hong Kong construction industry	<ul style="list-style-type: none"> <li>-Effective accident reporting.</li> <li>-High line management commitment.</li> <li>-Active supervisor's role.</li> <li>-Active personal role.</li> </ul>
2005	Teo, et al.	Investigating how project managers may increase the safety levels of construction sites	<p><b>Policy aspect</b></p> <ul style="list-style-type: none"> <li>-Understanding and implementation of safety management system.</li> <li>-Understanding and participation in occupational health and safety management system.</li> <li>-Understanding and implementation of permit-to-work system.</li> </ul> <p><b>Process aspect</b></p> <ul style="list-style-type: none"> <li>-Quality of subcontractors.</li> <li>-Understanding and implementation of safety procedures.</li> <li>-Carrying out work in a safe manner.</li> <li>-Carrying out work in a professional manner.</li> <li>-Type and method of construction.</li> </ul> <p><b>Personnel aspect</b></p> <ul style="list-style-type: none"> <li>-Management s attitude towards safety.</li> <li>-Supervisors and worker s attitude towards safety.</li> <li>-Contextual characteristics of workers.</li> </ul> <p><b>Incentive aspect</b></p> <ul style="list-style-type: none"> <li>-Monetary incentives.</li> <li>-Non-monetary incentives.</li> <li>-Disciplinary action.</li> </ul>

2007	Aksorn	Evaluating Critical success factors influencing safety program performance in Thai construction projects	<ul style="list-style-type: none"> <li>-Clear and realistic goal</li> <li>-Good communication</li> <li>-Delegation of authority and responsibility</li> <li>-Sufficient resource allocation</li> <li>-Management support</li> <li>-Program education</li> <li>-Continuing participation of employees</li> <li>-Personal motivation</li> <li>-Personal competency</li> <li>-Teamwork</li> <li>-Positive group norms</li> <li>-Personal attitude</li> <li>-Effective enforcement scheme</li> <li>-Safety equipment acquisition and maintenance</li> <li>-Appropriate supervision</li> <li>-Appropriate safety education and training.</li> </ul>
2007	Hassan et al.	Perception of Building Construction Workers Towards Safety, Health	<ul style="list-style-type: none"> <li>-Fire prevention</li> <li>-Housekeeping</li> <li>-Scaffold/mobile tower</li> <li>-Sandblasting</li> <li>-Cartridge operated tools</li> <li>-Power tools/machine</li> <li>-Excavation</li> <li>-Heavy equipment</li> <li>-Concrete formwork</li> <li>-Gas/electric welding</li> <li>-Health and welfare</li> <li>-Compressed gas</li> <li>-Transportation</li> <li>-Air compressors</li> </ul>

## 2.9 SUMMARY

In this chapter, a comprehensive literature review was discussed with a wide spread of participants perspectives in the field of construction management at all construction steps. The literature regarding factors affecting safety performance have been fully reviewed, [Sawacha et al, (1999); Jannadi et al, (2001); Fang et al, (2004); Tam et al, (2004); Ng et al, (2005); Fung et al, (2005) Teo et al, (2005) Hassan et al, (2007) and Akrsn et al, (2007). Other literatures might have mentioned a factor or more they are: Fabiano et al, (2004); Siu et al, (2003); Mohamed (2002); Zhou et al, (2007); Campbell (2006); Kartam et al, (2000); Mattila et al, (1994); Jannadi (1995); Koehn et al, (1995); Jannadi(2008) and Baig (2001)]. A summary of the thesis study outcomes are presented in Table 2-1.



# CHAPTER THREE: THE CURRENT STATUS AND CASE STUDY

## 3.1 INTRUCTION

### 3.1.1 The Current Status in Sudan:

The current situation in Sudan has fallen far short of what it was seventies and eighties and early nineties and as stated in the Strategic National Occupational Health in 1997 and prepared a recommendation Health Organization and the most important reason for referral of many specialist in this area for the public good and adopt a federal system of government which resulted in the implementation of the mandates were and still lacks the existence of structures of solid infrastructure of trained personnel and medical devices and instrumentation of the environment and means of movement and aids the others and if we know that the volume of coverage of Occupational health services of good globally 10-20% and in developing countries, 5-10%, and developed 20-50%, we find that the mandate of Khartoum under the minimum, in spite of the efforts estimated by the management of occupational health state, thus leaving many groups factories large and many workshops and agricultural workers and labor unorganized without the environment of those service, and there are signs of hope on the horizon soon – how be the case in other states??

- ❖ It is mentioned in the report of the Director of Occupational Health mandate an inventory of obstacles facing the provision of such service from the weakness in the legislation and lack of stability of the staff working in teams, medical examination and the lack of the means of good movement, where is located continuous breakdowns, and poor coordination with the federal administration, especially in the field of training of cadres operating in the state.
- ❖ Now in Sudan is looking forward to a renaissance in construction and agricultural and large-scale industrial activities which are fraught with a lot of risk that lead to accidents and diseases of the work and risks of the profession, particularly lung disease and lung fibrosis, tuberculosis sores, lung and even lung cancer by presence of some radioactive material the oil it is something else, etc. Accompanied extracted from the gases and fumes and heavy metals and other chemicals causing skin diseases, reproductive disorder, the influence of the central nervous system, mental disorders as a result of the

remote places of work, whether by land or sea. Now industrialized countries complain (30-50%) of the pressure of work and problems of psychological and it requires attention by the State and companies operating more attention and transparency in performance and the work of statistics on accidents and diseases work and disturbances psychological order to be able to develop sound work plans to avoid those risk. In this context, I hope to make it clear that the situation threatens global risk professional with disastrous effects, especially in the construction industry.

So now, there were 2.3 million deaths annually because of the work distributed as follows from Statistics Labor Office:

1. 32% attributed of cancer.
2. 8% accident sand violence.
3. 23% circulatory diseases.
4. 18% disease transition.
5. 8% respiratory device.
6. 1% disturbance of the mind.

It has become the subject of occupational health and safety of the pressing requirements to keep pace with growing field of building work and service next to the pluses of many of the buildings and services in the welfare of communities, there are also implications of the a negatives determines the health of workers and the surrounding environment and has witnessed the nineteenth century changes steadily after the industrial revolution and world wars and the concomitant from the use of mechanized and chemicals, was born that feeling of caution and fear in communities in the absence of public authorities or labor organization at the time, leading some individuals to lead the reform movement in term of their sense of responsibility for ethical towards their fellow workers and society, especially children and women in the absence of the legislation regulating.

It is well known that Britain has been the beginning of the Industrial Revolution was the children worst victims of the Industrial Revolution as it was the workers, including children work for (14-15)hours a day plants textile and so on the first legislation to protect their health by reducing the hours of work in 1802, a special legislation to maintain the health and leave the implementation to the selected individuals from the local clergy and judges so called "honorary visitors" were given the powers if of labor inspectors. 1833 first established the inspection work of

government to monitor the health of workers, in 1844 was the introduction of operational standards related to compel the owners of establishments and factories to apply the rules of prevention identified by the authority to inspect and report on accidents at work and is worth mentioning that France was experiencing conditions similar to but worse than Britain the some industries were mainly dependent on the employment of children between the age of (6-8) years working continuously for a period of up (16-18) hours per day. 1841, France passed the law governing the work and use of children in the industry especially stressful and dangerous work that uses the mechanical energy. The 1893 law include requirements and standards for inspection and enforcement to be accurate in this context that we hope to supply the following on the status of the use of children today:

- Came the report of the Director General of the Arab Labor Organization in 2004.
- An estimated working child in developing countries (250) million children between the ages of (5-14) years.
- 61% continent of Asia, Africa, 32% about 41% of the item in age (5-14) in general, and the rest of the 7% Latin American countries.
- Newspaper came last minute on 07/08/2010 under the title: "Stories and Tragedies – Study and raise the alarm indicated a high rate of working Children in Sudan".
- Has been out of the school before 7 years in Khartoum, Gazira, Kassala and the results is :
  - 23.3% working in the industrial sector.
  - 48.9% working in the street and the market.
  - 24% are exposed to the sun Hager Holocaust.
  - 10% are exposed to cuts and fractures.
  - 25.1% were beaten by their superiors.
  - 7.2% are to carry the works.

### **3.1.2 THE NATIONAL LAWS ON OCCUPATIONAL HEALTH AND SAFETY:-**

There are several local and international laws governing the safety and rights of workers, including local and we will look for some materials that are interested next to the construction industry:

- 1/ Act on Compensation for work-related injuries for the year 1981.
- 2/ Industrial Security Act of 1976.
- 3/ List of conditions and technical specifications of safety measures for the year 2008 (Khartoum State).

#### **3.1.2.1 Act on Compensation for work-related injuries for the year 1981**

This law identified "Work injury" as injury arising from an accident at work or because of injury or one of the occupational diseases listed in Annex Table Labour Law for the year 1997, For the purposes of this law is injury arising from an accident at work or because of, or injury to one occupational diseases contained in Annex Table Labour Law for the year 1997, if it led to the death of the worker when they occur or resulted in a deficit of not less accounted for 40%, regardless of whether Working at the occurrence of such injury, contrary to the provisions of any law or regulations to be applied to the service or contrary to any instructions issued by the employer or on behalf of, or was acting without instructions from the employer, if the acts, which was carried out related to the purposes of workmanship employer or its.

It is not permitted to end the contract of employment of any worker because of his absence from work for treatment because of a work injury occurred to him to be cured and decided not fit for service.

We find that this law had committed the employer to pay compensation

**Article 6: of the responsibilities of reporting work-related injury and death.**

**Article 7: pay during the period of absence from work due to work-related injury.**

**Article 8: of the medical examination and treatment.**

**Article 9: apply for compensation and loss of the right to compensation.**

**Article 10: entitlement to compensation.**

**Article 12: compensation for the death of an injured worker.**

**Article 13: compensation in case of total disability.**

**Article 14: compensation in case of partial disability.**

**Article 20: compensation in case of occupational diseases.**

**Article 25: obligations of contractors and sub-contractors.**

**Article 28: permissible claim for compensate for the tort responsibility and so on.**

**Article 29: mandated insurance employers.**

### **3.1.2.2 Labor law for the year 1997**

labor law care about injured workers and all the accidents that occur in any factory during daily working hours, which may cause death, fire or explosion or disable any worker for his working performance for a day or more and must be reported by the end of the first day and the employer must make his workers to know the dangers of the profession and means of prevention and the completion of the necessary precautions to protect them.

**Article 24: incident report.**

**Article 26: inform workers of the dangers of the profession.**

**Article 27: train workers.**

**Article 28: Duties of workers.**

**Article 29: shut down factories and industrial processes.**

### **3.1.2.3 List of conditions and technical specifications of safety measures for the year 2008 (Khartoum State).**

The list focused on taken the necessary measures for the safety of buildings and the safety of the construction work and neighboring buildings, staff and administration in all phases of the project before the project and when the construction work and the list has committed people who work in this section :

-Strengthen the excavations and the use of ready-mixed concrete on the multiple floors and obtain site ratification and design mixes with standard specifications and work tests that necessary and storing materials in scientific and safety manner and the presence of engineers or supervisors and do not storing materials on the public highway and the use of rubble pipe of high buildings with a banner showing the owner and the contractor, as well as about the site with detailed graphics rendering determine the type and design of fence and the means of safety And to take the

necessary means of safety so as not to affect the neighbors and passers-by and take safety measures for workers, such as wearing helmets with the timeliness of work in each area, whether residential or industrial investment or commercial.

In the case of violation of safety laws is entitled to those responsible to stop building and decision-making by type of offense Anyone who violates the provisions of this regulation shall be punished by the penalties provided clock cases in the law regulating construction in the state of Khartoum in 2008.

## **3.2 STUDY CASE IN KHARTOUM STATE:**

### **3.2.1 مشروع ابراج الهيئة بكافوري**

#### **❖ Alhaiaa towers project in Kafouri**

The project consists of two Administrative buildings under construction Each building consists of 11 floors plus the ground floor and basement, offices, consultant offices, reception office, security office, small mosque, iron store, stories, workers path rooms and path rooms for others.

#### **The contractor:**

Advanced Engineering works company.

#### **The consultant:**

Borouge Engineering Consultants

#### **The Owner:**

Security Central

The contactor company has a department for safety and health and they put a whole safety plan for this project. They appoint safety supervisor, security supervisor and first aider.

#### **▪ Public protection and information**

- The whole site is fenced properly to protect the public from going inside the working area and to protect the material from being stolen and there are reception for visitors and security men.
- There a notice displayed at the entrance warning all visitors to inter the work site without permit.
- When work finishes, they make sure that all site plant and remaining vehicles are immobilized and all piled and stacked materials is safe.

- They didn't give the visitor who came inside the site helmet to wear which may expose the visitor to risks.
- When work finishes, they didn't make checks if the flooded areas, excavations, openings are covered or protected by barriers and they didn't make sure that the access to scaffolding is removed or blocked.
  - **Fall prevention / protection**
- Most open edges and holes appropriately protected to guard against falls of people and materials.
- They didn't provide their workers with personnel fall protection like a travel restraint system, fall-restricting system and fall-arrest system.
- There is a net to prevent people from falling and from material falling.



**Picture (3-1)**

Alhaiya towers project in Kfoury taken by researcher

- **Safe access and site tidiness**
- The working area is not tidy and it doesn't meeting an acceptable standard of housekeeping.
- The collection and disposal of waste it doesn't adequately organized they put the wastes in carriers and these carriers are not supported by the building in a safe manner.
- There no adequate lighting in main and common areas.

- They accumulate the material in the hallways and in the building and they didn't take into account of the maximum load of the building.



**Picture (3-2)**  
Alhaiya towers project in Kfoury taken by researcher

### **Scaffolds**

- The scaffold doesn't match safety specification.
- They didn't make checks and inspections to ensure if that the scaffolds are safety to use but it's erected by a competent person.



**Picture (3-3)**  
Alhaiya towers project in Kfoury taken by researcher

## Ladders and stepladders

- The ladders and steps don't have a guard rail which cause falling risk to the workers.
- They didn't make checks if ladders secured before use to prevent slipping.



**Picture (3-4)**

Alhaiya towers project in Kfoury taken by researcher

## Cranes and lifting appliances

- The cranes inspected every 3 month by competent person.
- There is no slingers or banksmen with the crane to help the crane drivers in identifying the weight and center of gravity before lifting a load and to direct the crane movement and control it in safety way to a void risks.

## Site traffic and vehicles

- There is warning sign posted in the gate of the site explaining the specific speed limits for the vehicle drivers within the site (20km/hr).
- There is no site traffic plan to identify separate pedestrian and vehicle routes.



**Picture (3-5)**

Alhaiya towers project in Kfoury taken by researcher

## Fire and other emergencies

- There is signs in some floors defines the floor number and the escaping exits in case of fire.
- There are no fire extinguishers present in the site at all.
- There no any means of raising the alarm, which is known to be clearly audible at all points on the site.
- There is no site emergency plan, detailing steps required to evacuate the site in case of fire and for confined space rescue where appropriate.
- There is no effective smoking ban where flammable materials are used, stored or installed, the workers smoke everywhere.

## Electricity

- -In the work area accumulate timber next to the electrical box, leading to the likelihood of a fire risk, as well as conductive wires pass wet and damp areas.
- There no appropriate system in place to ensure that the temporary electrical supply system is checked by a competent person at appropriate intervals.



**Picture (3-6)**

Alhaiya towers project in Kfoury taken by researcher

## Welfare

- There is water cooler for the workers at the work site.
- There are first aid requirements in the work site to rescue the injured worker before taking him to the hospital.

- There is area for the workers to take rest, eating and smoking cigarettes at their break time, but this break area is also used as a metal workshop.
- There is a small mosque in the site to pray so; the workers can't go out the site for praying.
- There is an adequate path rooms for workers in average (1path for every 50 workers).



**Picture (3-7)**

Alhaiya towers project in Kfoury taken by researcher

## **Noise**

- There are no precautions to reduce the risk of noise.-

## **Personal protective equipment**

- -There is warning signs separated in the site enforce the worker to wear their PPE and to make them aware of the importance of safety and how to keep the site and themselves safety and how do they do if risks happened .
- They didn't give the workers the PPE to wear that is because the workers aren't constant and they consider it just extra cost to the expense of the project.

## Signs, Signals and Barricades

- There are a number of signs distributed within the work site advises workers to wear personal protection equipment and guidance in the event of injuries or fires.



Picture (3-8)

Alhaiya towers project in Kfoury taken by researcher

## **CHAPTER FOUR: RESEARCH METHODOLOGY**

### **4.1 INTRODUCTION**

This chapter discusses research procedure and the method used to conduct the research related to its objectives that has been highlighted in Chapter 1. The method used in this research is quantitative.

The methodology that was adopted for this study is the questionnaire survey. The information or data gathered using questionnaires focus on selected wider spectrum of respondent from construction industry in Khartoum.

This chapter describes the methodology that was used in this research. The adopted methodology to accomplish this study uses the following techniques: review of literature related to safety performance, the information about the research design, research Strategies, questionnaire design, questionnaire validity, questionnaire reliability, research structure and statistical data analysis.

### **4.2 RESEARCH DESIGN**

The role of research design is to connect the questions to data. Design sits between the two, showing how the research questions will be connected to the data, and the tools and procedures to use in answering them. Research design must follow from the questions and fit them with data. The design is the basic plan for a piece of empirical research, and includes main ideas such as strategy, sample, and the tools and procedures to be used for collecting and analyzing empirical data (Punch, 2000).

### **4.3 RESEARCH STRATEGIES**

For conducting empirical research, there are two methods of data collection: Qualitative and quantitative. These two methods have their strengths and weaknesses. The qualitative method permits researchers to study selected issues in depth and details.

Approaching fieldwork without being constrained by predetermined categories of analysis contributes to the depth, openness, and detail of qualitative inquiry.

The quantitative method, on the other hand, requires the use of standardized instruments so that the varying perspectives and experiences of people can fit a limited number of predetermined response categories, to which number are assigned.

The advantage of a quantitative method is that it is possible to measure the reactions of a great many people to a limited set of questions, thus facilitating comparison and statistical aggregation of the data. This gives a broad, generalizable set of findings presented succinctly and parsimoniously. By a contrast, a qualitative method typically produces a wealth of detailed information about much smaller number of people and cases.

This increases understanding of the cases and situations studied but reduce generalization (Patton, 1990). In order to avoid their respective disadvantages, one important way to strengthen a research design is to use both qualitative and quantitative methods. A number of research strategies are available for conducting social sciences: Experiments, surveys, histories, case studies, and the analysis of archival information. The kind of research strategies adopted in a study should be dependent on three conditions: The type of research questions, the control an investigator has over actual behavioral events and the focus on contemporary, as opposed to historical, phenomena. However, the first and the most important condition for differentiating among the various research strategies (Yin, 1989). Based on the two research question proposed in this study, the research strategies of the literature review, and a questionnaire survey were adopted in this research.

#### **4.3.1 LITERATURE REVIEW**

The research question "What is the effect of safety precautions on construction performance?" is descriptive in nature. According to (Punch, 2000), a descriptive study set out to collect, organize, and summarize information about the matter being studied: it is concerned with making complicated things understandable. For answering this research question, a literature review approach was the best strategy. The literature review on all aspects of performance helped to provide a detailed understanding of the state of performance today in term of its research and its application within projects. The literature review identified the major factors which effect on construction safety performance. Thus the research question was answered.

#### **4.3.2 QUESTIONNAIRE SURVEY**

Based on the existing theories, a theoretical model was derived. In essence, to answer the second research question is to verify a theory. According to (Punch, 2000), a theory verification study aims to test a theory or, more accurately, to test hypotheses

derived from the existing theory .It is a common practice in science areas that have traditionally emphasized quantitative research. Such a study start with a theory, deduces hypotheses from it, and proceeds to test these hypotheses. Thus, a questionnaire survey was the most appropriate strategy to answer this second research question.

The greatest advantage of a questionnaire survey is it lower cost compared to other method. A questionnaire survey can be used only when the objectives of the study is clear and not complex (Bourque and Fielder, 1995). In the area of the safety in construction project, many researchers have been conducted using questionnaire surveys to collect information (e.g., Ng, 2001; Fung, 2005; Ng, 2005; Hassan, 2007; Aksorn, 2007). These researchers tested the effect of safety precaution in construction performance using questionnaire surveys. In this study, the questionnaire survey was used to obtain information about factors that effect on construction performance from a wide range of Sudanese construction firms. Such data could be used to examine the effects of safety factors on these firms and its overall project performance.

#### **4.4 RESEARCH SAMPLE**

Construction firms in Khartoum state were selected for investigation due to the state's position as the center of construction firms in Sudan, as well as for reasons of practicality and convenience perceived by research.

#### **4.5 QUESTIONNAIRE DEVELOPEMENT**

In this field of construction project, a number of researchers have used questionnaire surveys. These included, for example, Fang (2004), Ng ( 2001),Teo (2005),Tam (2005), Fung (2005), Ng (2005), Hassan, (2007), and Aksorn ( 2007). All of these researchers developed their questionnaires for data collection, based on their own research purposes, thus, their questionnaire differed from each other. After the questionnaires were examined, it was determined that none fully met the requirements of this research. Therefore, it was necessary to develop a new research questionnaire. However, the questionnaires developed by these researchers didn't give some insights into developing the questionnaire required for this research purpose. In fact, the design of the research questionnaire was highly dependent on the concepts of theoretical constructs and the operation of the theoretical constructs. The major issues

of designing the questionnaire were to determine measurement questions, which respondents would be asked to answer. During the process of designing a research questionnaire, it should be noted that the questionnaire survey was used to study the effect of safety precautions on construction performance. Therefore, the questionnaire should cover the scopes of this area. The items develop for measuring factors at the organization level and at the project level should be based on the concept of these factors situation presented in chapter 2. In addition, question wording should be given sufficient attention when building up measurement items.

#### **4.5.1 QUESTIONNAIRE MODIFICATION**

In his research most of the literature reviewed was in English, thus the questionnaire was first developed in English. However, It was actually used for collecting data in Sudan. Therefore, the English version had to be translated into Arabic. This translation might have biased the original design of the questionnaire. Various measures were taken in order to minimize these potential problems. The English version was 77 items which was translated into Arabic by the supervisor and the researcher themselves. Some Arabic terms were translated into English by providing additional explanations with English terms itself, so that the respondents could better understand them. After translation, the Arabic version of the questionnaire was distribute to 10 person who have a professional knowledge in the field of construction project and worked with different Sudanese construction firms. They were asked whether: (1) The items were stated in shared vocabulary, (2) There were precise and unambiguous, (3) There were biased wordings, (4) They could answer these questions. They return the questionnaire with their comments, and some alterations were made according to their suggestions. The Arabic version of the questionnaire was formally pre-tested on various people (i.e., contactors, researchers, practitioners, and project managers). The researcher interviewed these people and asked them to provide feedback on ease of comprehension, clarity of the specific items, suggestion for possible change, and suggestion for additional items, etc. Their suggestions were then carefully evaluated by the researcher and the Arabic version of the questionnaire was further modified. After this step, the researcher was confident that the questionnaire could be used for the large-scale survey. In Appendix (2), the final Arabic version of the questionnaire consists of 77 items (questions) to measure the factors that affect the safety performance in construction project performance in

Sudan. Appendix (1) lists the instrument that the researcher translated back into English from the final Arabic version.

## **4.6 DATA ANALYSIS**

For testing the theoretical model hypothesized in this study, the measurement instrument should be reliable and valid. Thus, they should be evaluating for reliability and validity. In evaluating measurement instrument, reliability analysis, item analysis, and factor analysis should be conducted in order to understand whether measurement instrument was reliable and valid. The SPSS IBM 16 program was used evaluation.

### **4.6.1 DATA COLLECTION**

Data collection is considered as crucial stage in gathering all required information, from the fundamental in achieving main objectives of the study. Basically, the main data were collected from literature review. All factors obtained from previous study were listed. The main data was a platform for the formulation of questionnaire.

The second data is the finalized questionnaire as the main data to be used for the analysis for the study. The second data are collected from questionnaire survey. The data collected through questionnaire survey delegated to project managers and participants from firms that involve in stages of construction project.

## **4.7 MEASUREMENT EVALUATION**

### **4.7.1 INTRODUCTION**

In this study, a research questionnaire was developed and used to obtain empirical data from construction firms in order to test the theoretical model hypothesized in this study. In the questionnaire, there was one measurement instrument used to measure the factors that effect on the construction project performance, respectively. The instrument had some measurement scales (see Appendices 1). Before testing the theoretical model, it was necessary to first evaluate the reliability and validity of the instrument; it is only on the basis of reliable and valid measurement scales that hypothesis testing can be conducted.

### **4.7.2 METHODOLOGY**

#### **4.7.2.1 RELIABILITY**

Reliability refers to whether you get the same answer by using an instrument to measure something more than once (Bernard, 2000). Reliability concerns the extent to

which an experiment, test, or any measuring procedure yields the same results in repeated trials (Carmines and Zeller, 1979); it is statistical measure of how reproducible the survey instrument's data are (Litwin, 1995). There are four methods commonly used for assessing reliability, namely, (1) the test-retest method, (2) the alternate-form method, (3) the split halves method, and (4) the internal consistency method (Nunnally, 1967).

Internal consistency reliability is commonly used psychometric measure in assessing survey instrument and scales. Internal consistency is an indicator of how well the different items measure the same concept. This is important because a group of items that purports to measure one variable should indeed be clearly focused on that variable. Internal consistency is measured by calculating a statistic known as Crobach's coefficient alpha (Cronbach, 1951; Nunnally, 1967). Coefficient alpha measures internal consistency reliability among a group of items combined to form a single scale. It is a statistic that reflects the homogeneity of the scale. Generally, reliability coefficient of **0.70** or more is considered good (Nunnally, 1967).

#### **4.7.2.2 ITEM ANALYSIS**

Nunnally (1967) developed a method of evaluating the assignment of items to scales that considers the correlation of each item with each scale. Specifically, the item-score to scale-score correlations are used to determine whether an item belongs to the scale as assigned, to some other scales, or should be eliminated. The scale-score is obtained by computing the arithmetic average of the scores of the items that comprise that scale. The values of item to scale correlations should be greater than 0.50; those lower than 0.50 do not share enough variance with the rest of the items in that scale. Therefore, it is assumed that the items are not measuring the same construct and it should be deleted from the scale (Kemp, 1999). It was judged that item analysis should be performed in order to understand whether items were assigned appropriately.

#### **4.7.2.3 VALIDITY**

Validity is defined as the extent to which any instrument measures what it is intended to measure. The three most popular methods of evaluating the validity of a measurement instrument are content validity, criterion-related validity, and construct validity (Carmines and Zeller, 1979). However, due to limitations of some

instruments that are known to be valid, many researchers did not evaluate the criterion-related validity of their instruments (e.g., De Jong, 1999; Kemp, 1999). In this study, only content validity and construct validity were conducted in order to evaluate the measurement instruments.

#### **4.7.2.4 CONTENT VALIDITY**

Content validity depends on the extent to which an empirical measurement reflects a specific domain of content. It cannot be evaluated numerically-it is a subjective measure of how appropriate the items seem to various reviewers with some knowledge of the subject matter.

The evaluation of content validity typically involves an organized review of the survey's contents to ensure that it includes everything it should, and does not include anything it should not. Strictly speaking, content validity is not a highly scientific measure of a survey instrument's accuracy. Nevertheless, it provides a solid foundation on which to build a methodologically rigorous assessment of a survey instrument's validity. In this research, however, it was argued that the three scales for measuring safety project performance had content validity since the development of these measurement items was based mainly on an extensive review of the literature and detailed evaluations by academicians and practitioners. The references list the literature reviewed by the author during the period of conducting this research, and the research methodology section addresses the detailed process of developing the research questionnaire.

#### **4.7.2.5 CONSTRUCT VALIDITY**

Construct validity measures the extent to which the items in a scale all measure the same construct (Flynn et al., 1994), and can be evaluated by the use of factor analysis. Factor analysis addresses the issue of analyzing the interrelationships among a large number of items<sup>16</sup> and then explaining these items in terms of their common underlying dimensions (factors). In fact, the general purpose of factor analysis is to find a way of condensing or summarizing the information into a smaller set of new composite dimensions (factors) with a minimum loss of information (Hair et. al., 1992). There are two forms of factor analysis, namely, exploratory factor analysis and confirmatory factor analysis. According to Hair et al.(1992), there is continued debate concerning the appropriate role of factor analysis. Many researchers consider it only

exploratory, useful in searching for structure among a set of variables, or as a data reduction method. In this study, two instruments were developed in order to measure project performance.

These instruments had never been used before. Therefore, factor analysis in this context was exploratory in nature rather than confirmatory; thus, exploratory factor analysis was adopted in this study.

According to Hair et al. (1992), there are two methods of exploratory factor analysis: Principal component analysis and common factor analysis. Principal component analysis is appropriate when researchers are primarily concerned about the minimum number of factors needed to account for the maximum portion of the variance represented in the original set of items. In contrast, common factor analysis is appropriate when the primary objective is to identify the latent dimensions or constructs represented in the original items. According to the aim of conducting factor analysis in this study, principal component analysis was selected as it can determine how and to what extent items are linked to their underlying factors (Byrne, 1998).

Principal component analysis can help to identify whether selected items cluster on one or more than one factor. Particularly, three or more items are selected for measuring a latent construct. Factor loadings are used to present these relations. Factor loadings greater than 0.30 are considered significant; loadings of 0.40 are considered more important; if the loadings are 0.50 or greater, they are considered very significant (Hair et. al, 1992). In this study, a factor loading of 0.50 was used as the usual cut-off point. According to Hair et al. (1992), the most commonly used method of determining whether items are loading on one factor is the latent root criterion. Only the factors having latent (eigen values) greater than 1 are considered significant; those with eigen values less than 1 are considered insignificant and are disregarded.

### **4.7.3. PROJECT PERFORMANCE INSTRUMENT**

#### **4.7.3.1 RELIABILITY**

##### **4.7.3.1.1 Cronbach's Alpha**

There were three scales for measuring the project stages constructs for Sudanese construction firms. For each scale, there were a number of items to measure it (see Appendix 1). After all data were entered into a computer, the SPSS 16 reliability program was performed separately for the items of each scale. Table (3-1) lists

Cronbach's alpha for different project scales. This table shows that the reliability coefficients ranged from 0.917 to 0.973, indicating that some scales were more reliable than others. Accordingly, the instrument developed for measuring safety project performance constructs was judged to be reliable.

Table (4-1) the reliability statistics:

Scale		Reliability Statistics	
	Factors	Cronbach's Alpha	No. of Items
1	At Organization Level (A)	.917	20
2	At Project Level (B)	.973	57

Source: field survey

#### 4.7.3.1.2 Half Split Method

This method depends on finding Pearson correlation coefficient between the means of odd questions and even questions of each field of the questionnaire. Then, correcting the Pearson correlation coefficients can be done by using Spearman Brown correlation coefficient of correction. The corrected correlation coefficient (consistency coefficient) computed according to the following equation:

Consistency coefficient =  $2r/(r+1)$ , where r is the Pearson correlation coefficient. The normal range of corrected correlation coefficient ( $2r/ r+1$ ) is between 0.0 and 1.0 As shown in table 4-2, all the corrected correlation coefficients values are between 0.0 and 1.0 and the significant ( $\alpha$ ) is less than 0.05 so all the corrected correlation coefficients are significance at  $\alpha = 0.05$ . It can be said that according to the Half Split method, the groups are reliable.

Table (4-2) the correlation statistics:

#### Correlations

		av.odd	av.even
av.odd	Pearson Correlation	1	.948**
	Sig. (2-tailed)		.000
	N	50	50
av.even	Pearson Correlation	.948**	1
	Sig. (2-tailed)	.000	
	N	50	50

\*\* . Correlation is significant at the 0.01 level (2-tailed).

Source: field survey

From the above table we find that the correlation coefficient is equal to 0.948 and when we calculate the correct correlation coefficient using the Spearman-Brown equation, we find that the reliability coefficient is equal to:

$$\text{Correlation coefficient} = \frac{2 \times 0.948}{1 + 0.948} = 0.973$$

### 3.4.7.1.3 Cronbach's Coefficient Alpha

Table (4-3) Cronbach's Coefficient Alpha statistics:

#### Item-Total Statistics

	Scale Mean if Item Deleted	Scale Variance if Item Deleted	Corrected Item-Total Correlation	Cronbach's Alpha if Item Deleted
A.Q1	236.45	2980.723	.625	.980
A.Q2	236.90	2971.757	.637	.980
A.Q3	236.94	2946.662	.741	.980
A,Q4	237.00	2950.467	.761	.980
A.Q5	237.16	2955.806	.747	.980
A.Q6	237.42	2960.318	.753	.980
A.Q7	237.35	2976.570	.658	.980
A,Q8	237.32	2967.426	.715	.980
<b><u>A.Q9</u></b>	<b><u>237.23</u></b>	<b><u>3009.914</u></b>	<b><u>.387</u></b>	<b><u>.980</u></b>
A.Q10	237.10	2938.690	.758	.980
A.Q11	236.48	2958.791	.674	.980
<b><u>A.Q12</u></b>	<b><u>237.45</u></b>	<b><u>3002.523</u></b>	<b><u>.402</u></b>	<b><u>.980</u></b>
A.Q13	237.06	2980.396	.536	.980
A.Q14	236.87	2980.383	.608	.980
<b><u>A.Q15</u></b>	<b><u>237.35</u></b>	<b><u>3075.503</u></b>	<b><u>-.152-</u></b>	<b><u>.981</u></b>
A.Q16	237.26	2959.665	.726	.980
A.Q17	237.03	2957.299	.772	.980
<b><u>A.Q18</u></b>	<b><u>237.26</u></b>	<b><u>3035.265</u></b>	<b><u>.159</u></b>	<b><u>.980</u></b>
A.Q19	237.10	2967.090	.702	.980
A.Q20	237.23	2982.514	.555	.980
B.Q1	236.03	2995.299	.546	.980
<b><u>B.Q2</u></b>	<b><u>235.97</u></b>	<b><u>3010.432</u></b>	<b><u>.494</u></b>	<b><u>.980</u></b>
B.Q3	236.48	2981.391	.703	.980
B.Q4	236.61	2967.045	.698	.980

<b><u>B.Q5</u></b>	<b><u>236.06</u></b>	<b><u>3011.596</u></b>	<b><u>.460</u></b>	<b><u>.980</u></b>
B.Q6	236.45	2993.856	.630	.980
<b><u>B.Q7</u></b>	<b><u>236.06</u></b>	<b><u>3008.462</u></b>	<b><u>.439</u></b>	<b><u>.980</u></b>
B.Q8	236.29	2979.546	.653	.980
B.Q9	236.19	2996.161	.616	.980
B.Q10	236.81	2964.228	.780	.980
B.Q11	236.19	2990.828	.600	.980
B.Q12	236.74	2973.731	.724	.980
B.Q13	237.23	2988.181	.567	.980
B.Q14	236.48	2992.391	.530	.980
B.Q15	236.39	2980.778	.641	.980
B.Q16	236.35	2983.637	.616	.980
B.Q17	236.81	2963.828	.742	.980
B.Q18	236.77	2972.647	.681	.980
B.Q19	236.29	3001.880	.510	.980
B.Q20	237.10	2959.490	.727	.980
B.Q21	236.77	2969.914	.612	.980
B.Q22	236.19	2987.628	.544	.980
B.23	236.52	2984.991	.593	.980
B.Q24	237.23	2968.581	.711	.980
<b><u>B.Q25</u></b>	<b><u>236.32</u></b>	<b><u>3009.226</u></b>	<b><u>.441</u></b>	<b><u>.980</u></b>
<b><u>B.Q26</u></b>	<b><u>236.06</u></b>	<b><u>3032.862</u></b>	<b><u>.379</u></b>	<b><u>.980</u></b>
B.Q27	237.13	2961.849	.739	.980
B.Q28	237.29	2949.746	.818	.979
<b><u>B.Q29</u></b>	<b><u>236.61</u></b>	<b><u>2995.912</u></b>	<b><u>.484</u></b>	<b><u>.980</u></b>
<b><u>B.Q30</u></b>	<b><u>236.81</u></b>	<b><u>3001.161</u></b>	<b><u>.497</u></b>	<b><u>.980</u></b>
B.Q31	236.42	2993.918	.563	.980
B.Q32	236.48	2978.325	.665	.980
<b><u>B.Q33</u></b>	<b><u>236.39</u></b>	<b><u>2995.845</u></b>	<b><u>.485</u></b>	<b><u>.980</u></b>
B.Q34	236.77	2966.914	.676	.980
<b><u>B.Q35</u></b>	<b><u>236.42</u></b>	<b><u>3009.385</u></b>	<b><u>.456</u></b>	<b><u>.980</u></b>
B.Q36	237.16	2951.873	.813	.980
B.Q37	237.32	2948.359	.828	.979
B.Q38	236.71	2967.813	.606	.980
B.Q39	236.90	2973.824	.688	.980
B.Q40	236.39	2979.845	.648	.980

B.Q41	236.48	2987.258	.626	.980
<b>B.Q42</b>	<b><u>236.26</u></b>	<b><u>3006.065</u></b>	<b><u>.473</u></b>	<b><u>.980</u></b>
<b>B.Q43</b>	<b><u>235.84</u></b>	<b><u>3021.540</u></b>	<b><u>.413</u></b>	<b><u>.980</u></b>
B.Q44	236.68	2997.426	.522	.980
B.Q45	236.97	2993.699	.574	.980
B.Q46	236.58	2953.118	.824	.979
B.Q47	236.84	2962.473	.762	.980
B.Q48	236.90	2956.957	.703	.980
B.Q49	236.71	2970.013	.614	.980
B.Q50	236.94	2972.196	.577	.980
B.Q51	236.32	2972.492	.600	.980
B.Q52	236.77	2970.581	.634	.980
B.Q53	237.39	2973.578	.648	.980
B.Q54	237.16	2968.673	.737	.980
B.Q55	237.00	2958.333	.771	.980
B.Q56	237.19	2964.295	.770	.980
B.Q57	236.97	2943.832	.834	.979

Source: field survey

The Column (Corrected item-total Correlation) shows the discrimination coefficient for each paragraph and it is advisable to delete paragraphs with a low coefficient of positive discrimination is less than 0.50 or paragraphs that distinguish a negative coefficient in order to get a strong reliability coefficient and the previous results can be deleted paragraphs (A.Q9, A.Q12,A.Q15,A.Q18,B.Q2, B.Q5, B.Q7, B.Q25, B.Q26, B.Q29, B.Q30, B.Q33, B.Q35, B.Q42, B.Q43).

### 4.7.3.2 VALIDITY

To find the Validity of the passages we find correlation coefficients between the rate of each area and the overall rate of paragraphs and in the end the results are as follows:

Table (4-4) the validity statistics:

#### Correlations

		av.a	av.B	av.total
av.a	Pearson Correlation	1	.717**	.751**
	Sig. (2-tailed)		.000	.000
	N	50	50	50
av.B	Pearson Correlation	.717**	1	.999**
	Sig. (2-tailed)	.000		.000
	N	50	50	50
av.total	Pearson Correlation	.751**	.999**	1
	Sig. (2-tailed)	.000	.000	
	N	50	50	50

\*\* . Correlation is significant at the 0.01 level (2-tailed).

Source: field survey

The previous correlation coefficients transactions are acceptable stability of internal and statistically significant.

Thus, we may be sure of the validity and reliability of the paragraphs of resolution thus the questionnaire are valid for the application of the baseline study sample.

## 4.8 A Brief description of the respondent firms

### 4.8.1 Respondents Education Levels

Table (4-5) showed the respondents' education level in the construction industry. A majority of them, 70% are graduated, 20% of the respondents are post graduate. A minimum of them, only 20% are secondary.

Table (4-5) respondent's education Levels:

Level of Education	Percentage
Secondary	10%
Graduate	70%
Post Graduate	20%

Source: field survey

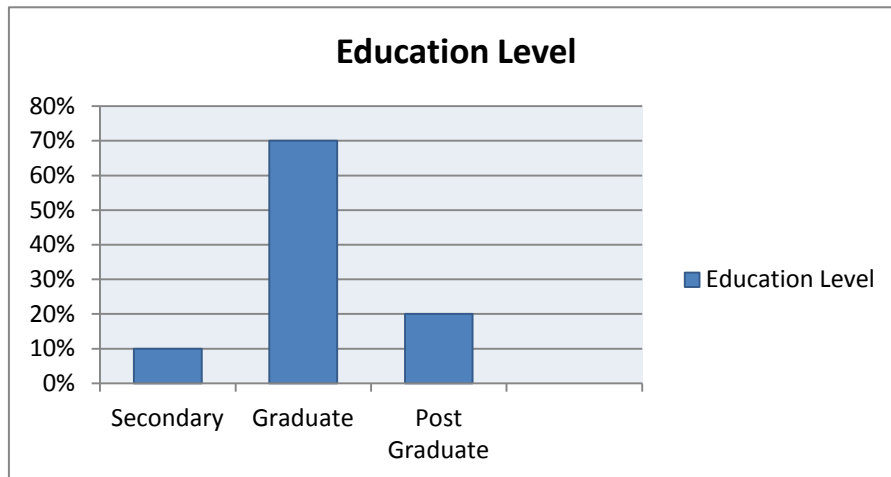

Figure (4-1) Respondents education level

#### 4.8.2 Respondents age:

Table (4-6) and Figure (4-2) shows that the majority of respondents 52% are of the age between 20 years to 30 years old, 28% are of the age between 30 years to 40 years old. Only 20% is more than 40 years old.

Table (4-6) the respondent's ages

Age	Percentage
(20-30)	52%
(30-40)	28%
More than 40	20%

Source: field survey

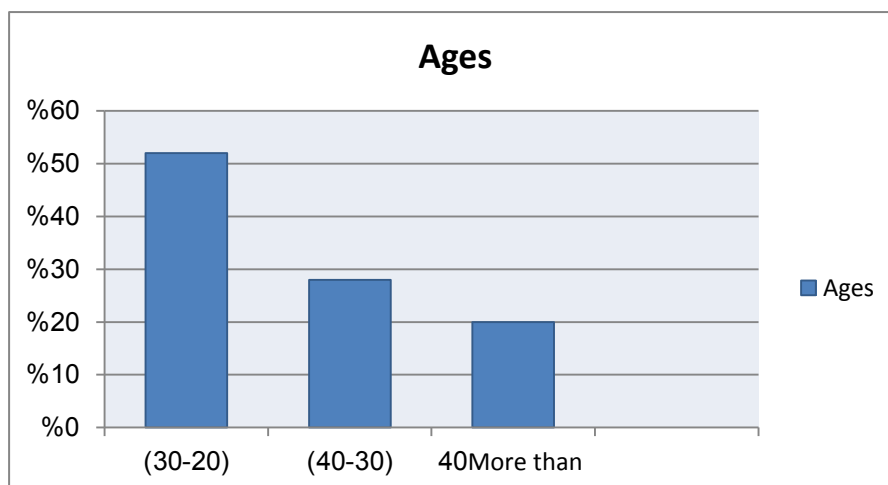

Figure (4-2) the respondent's ages

### 4.8.3 Respondents firm:-

Table (4-7) and Figure (4-3) shows that the majority of respondents 62% are working in contractor company, 30% of respondents are working in consultant company and 8% of respondent are working in government company.

Table (4-7) respondents firms:

Organization	Percentage
Government	8%
Consultant	30%
Contractor	62%

Source: field survey

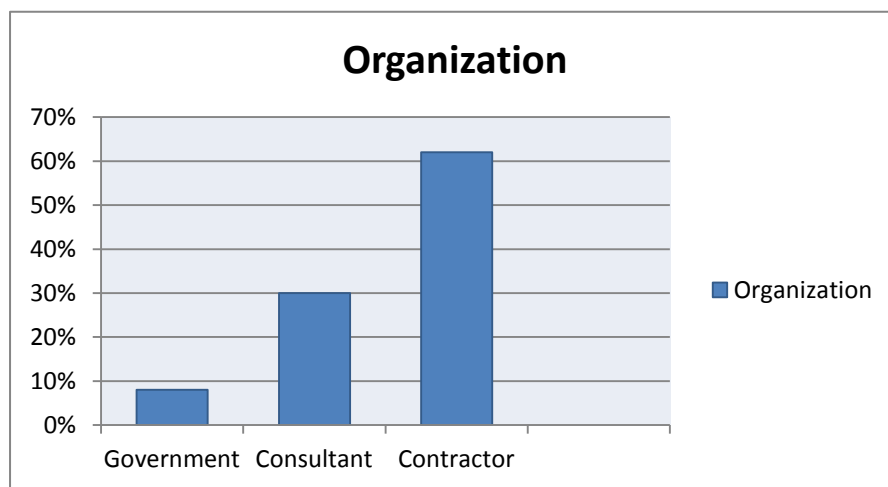

Figure (4-3) respondents firms

### 4.8.4 The respondent's career name:

Table (4-8) and Figure (4-4) shows that the majority of respondents 50% are contractor, 20% of respondents are Project Manager, 18% of respondent are Architecture and 12% of respondents are Owner Representative.

Table (4-8) respondent's career name:

Career Name	Percentage
Project Manager	20%
Contractor	50%
Architecture	18%
Owner Representative	12%

Source: field survey

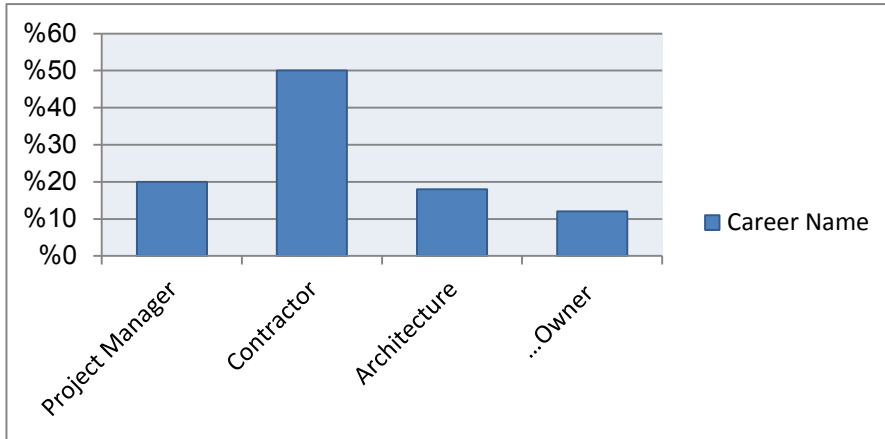

Figure (4-4) respondents career name

#### 4.8.5 Respondent’s experience:

Table (4-9) and figure (4-5) showed the respondents’ working experience in the construction industry. A majority of them, 42% have 5 to 10 years of experience, 23% of the respondents have less than 5 years of working experience in the field. A minimum of them, only 26% have More than 10 years of experience. This proves that there were many senior level executives in the construction industry.

Table (4-9) the work experience of the respondents:

Experience Year	Percentage
(1-5) years	32%
(5-10) years	42%
More than 10	26%

Source: field survey

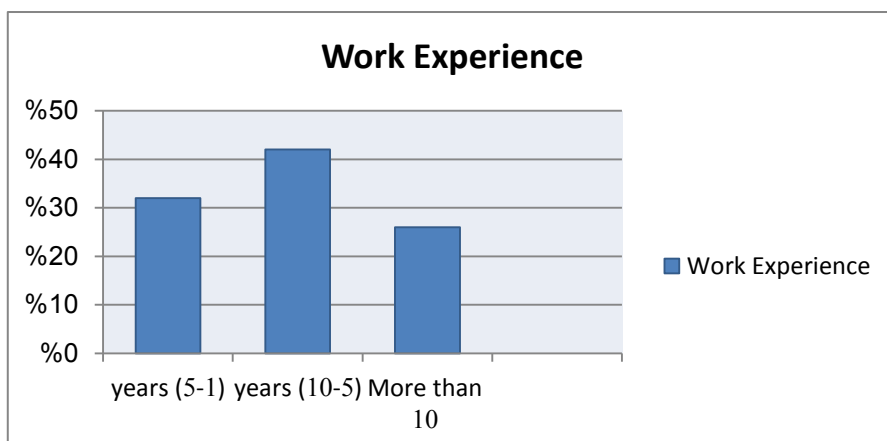

Figure (4-5) respondents work experience

#### 4.8.6 Number of Project of the Respondents:

Table (4-10) and figure (4-6) showed the respondents' Number of Projects in the construction industry. A majority of them, 46% have more than 10 projects, 28% of the respondents have (1-5) projects and 26% have (5-10) projects.

Table (4-10) respondents' Number of Projects:

No. of Projects	Percentage
(1-5) projects	28%
(5-10) projects	26%
More than 10	46%

Source: field survey

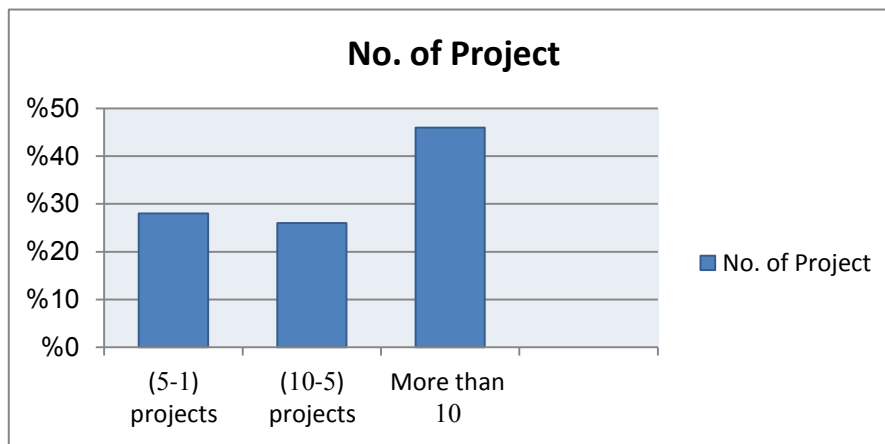

Figure (4-6) respondents' Number of Projects

## **CHAPTER FIVE: ANALYSIS AND DISCUSSION**

### **5.1 Introduction**

In the chapter four, the project performance instrument was reliable and valid, so the data obtained through this instrument can be used for data analysis. The data will then be processed and analyzed by SPSS program to generate the results which will then be tabulated and used for further discussion.

### **5.2 Field Study**

The qualitative data were generated from literature review, was used for construct the project performance instrument to generate the quantitative data from questionnaire survey.

So, the quantitative data generated from the questionnaire survey was analyzed using average index technique. The summary of data analysis for questionnaire survey will be tabulated in the next section. The result will be used as the basis for further discussion in the next chapter.

The developed questionnaire was distributed seventy (70) sets to targeted respondents within the locality of Khartoum contractors. The forty seven questionnaires were collected from respondents as 70% and 30% was returned and ignored from respondents.

### **5.3 Safety factors Analysis**

The questionnaires survey was conducted as explained in chapter 4, so the data collected and then will be analyzed in order to determine the factors that affecting on safety performance in construction sites.

### 5.3.1 Factors at an Organization Level:

Table (5-1) the direction of respondents towards Administrative Factors:

Items	Means		1=very disagree	2= disagree	3= neutral	4= agree	5=very agree	SUM	Scale average
A1	3.55	F	3	9	3	26	8	49	3
		%	6	18	6	52	16	98	
A2	2.82	F	7	19	5	14	5	50	3
		%	14	38	10	28	10	100	
A3	2.76	F	11	17	3	11	8	50	3
		%	22	34	6	22	16	100	
A4	2.74	F	8	20	4	13	5	50	3
		%	16	40	8	26	10	100	
A5	2.76	F	5	25	4	7	8	49	3
		%	10	50	8	14	16	98	
A6	2.40	F	9	27	3	7	4	50	3
		%	18	56	6	14	8	100	
A7	2.42	F	8	28	3	7	4	50	3
		%	16	56	6	14	8	100	
A8	2.32	F	8	28	7	4	3	50	3
		%	16	56	14	8	6	100	
A9	2.62	F	8	18	11	11	2	50	3
		%	16	36	22	22	4	100	
A10	2.72	F	10	21	1	9	9	50	3
		%	20	42	2	18	18	100	
A11	3.33	F	4	14	3	18	10	49	3
		%	2	28	6	36	20	98	
A12	2.50	F	13	16	3	14	2	48	3
		%	26	32	6	28	4	96	
A13	2.51	F	10	21	5	9	4	49	3
		%	20	42	10	18	8	98	
A14	2.84	F	3	17	18	7	4	49	3
		%	6	34	36	14	8	98	
A15	2.63	F	7	21	9	7	5	49	3
		%	14	42	18	14	10	100	
A16	2.49	F	9	22	5	11	2	49	3
		%	18	44	10	22	4	98	
A17	2.85	F	6	15	11	12	4	49	3
		%	12	30	22	24	8	98	
A18	2.79	F	8	16	7	12	5	48	3
		%	16	32	14	24	10	96	
A19	2.86	F	5	20	7	13	5	50	3
		%	10	40	14	26	10	100	
A20	2.64	F	10	16	9	12	3	50	3
		%	20	32	18	24	6	100	
<b>SUM</b>	54.55	F	144	390	121	224	100	988	
		%	288	780	242	448	200	1,976	
<b>Average</b>	2.73	F	7.2	19.5	6.05	11.2	5	49.4	
		%	14.4	39	12.1	22.4	10	98.8	

Source: field survey

- 1- With respect to the question of (A1) the respondents were asking (**Safety and Health are the upper management responsibility in your Organization**), from their answers the analysis shows the main of **3.55**, which is greater than the mean average (**3**), which is conclude that the most firms put the safety and health in their responsibility .

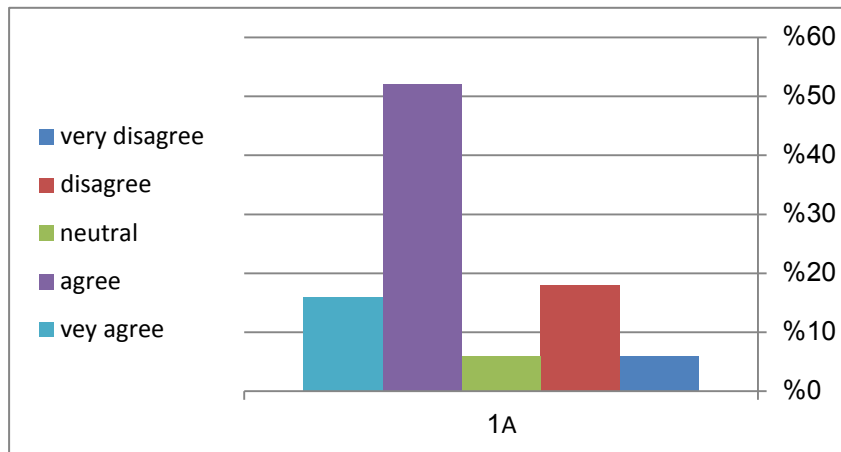

Figure (5-1) the upper management responsibility

- 2- With respect to the question of (A2) the respondents were asking (**Your organization upper management devote time to discuss safety issues with company safety coordinator**), from their answers the analysis shows the main of **2.82**, which is less than the mean average (**3**), which is indicates that most firms doesn't devote time to discuss safety issues.

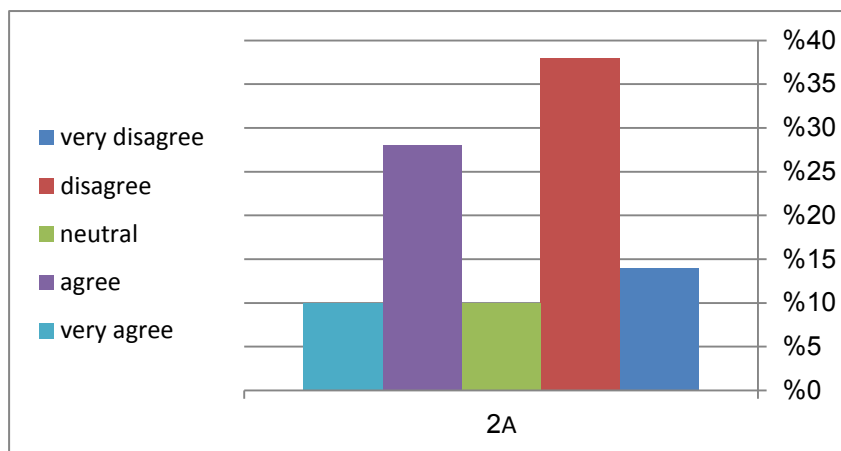

Figure (5-2) devoting time to discuss safety issues with safety coordinator

- 3- With respect to the question of (A3) the respondents were asking (Are there informal safety inspections made by the company safety coordinator), from their answers the analysis shows the main of 2.76, which is less than the mean average (3), which is indicates that most firms doesn't make safety inspections .

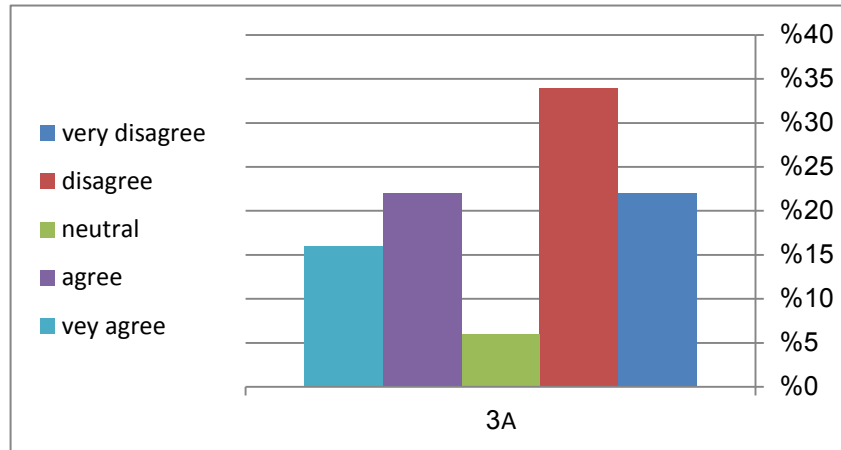

Figure (5-3) informal safety inspections

- 4- With respect to the question of (A4) the respondents were asking (We hold programmed Meetings between the field safety representatives, craft workers and sub contactors to discuss safety issues), from their answers the analysis shows the main of 2.74, which is less than the mean average (3), which is indicates that most firms doesn't aware of holding meetings to discuss safety issue.

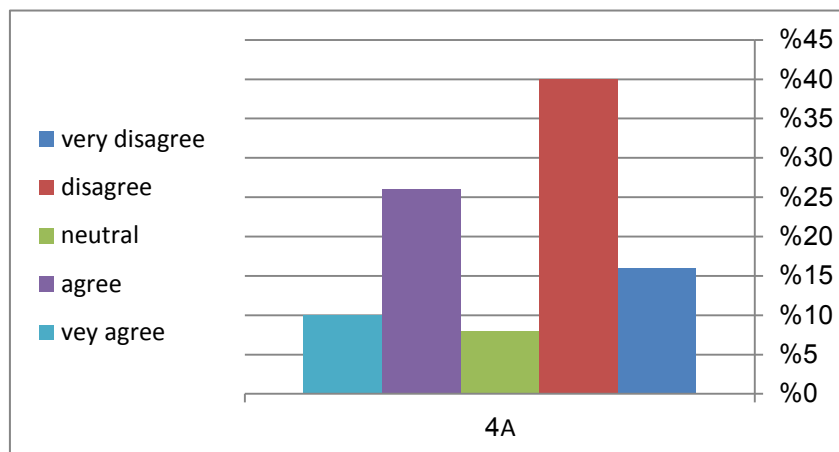

Figure (5-4) safety meeting

- 5- With respect to the question of (A5) the respondents were asking (**we have training program for new foremen and safety coordinators to make them aware of safety issues**), from their answers the analysis shows the main of **2.76**, which is less than the mean average (**3**), which is indicates that most firms doesn't concern to train anew foremen and safety coordinators if founded to make them aware about safety issues.

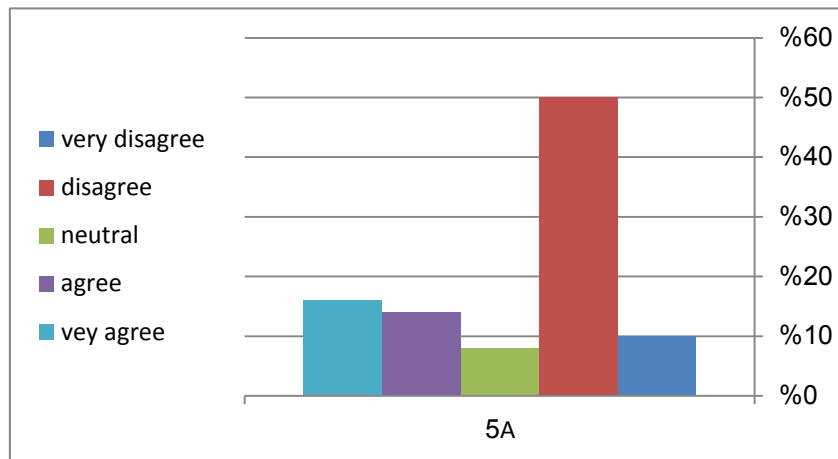

Figure (5-5) safety training for foremen and safety coordinator

- 6- With respect to the question of (A6) the respondents were asking (**we distribute safety booklets that has big effect in making workers aware of safety issues**), from their answers the analysis shows the main of **2.40**, which is less than the mean average (**3**), which is indicates that most firms doesn't concern about distributing safety booklets to educate workers which it has a big role to make worker know about the new in safety world.

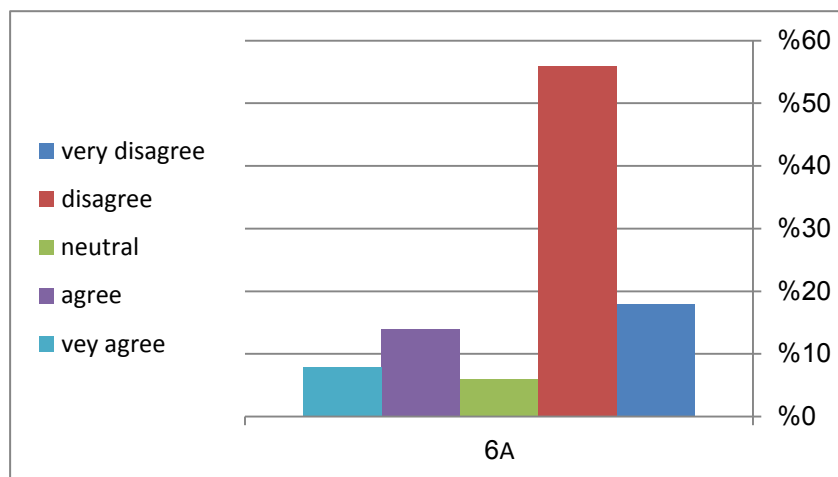

Figure (5-6) distributing safety booklets

7- With respect to the question of (A7) the respondents were asking (**In our organization we care about appointing a trained safety representative on the work site to assure safety performance**), from their answers the analysis shows the main of **2.42**, which is less than the mean average (**3**), which is indicates that most firms doesn't concern to appoint safety representative which may lead to un safety performance and the workers break the safety regulation.

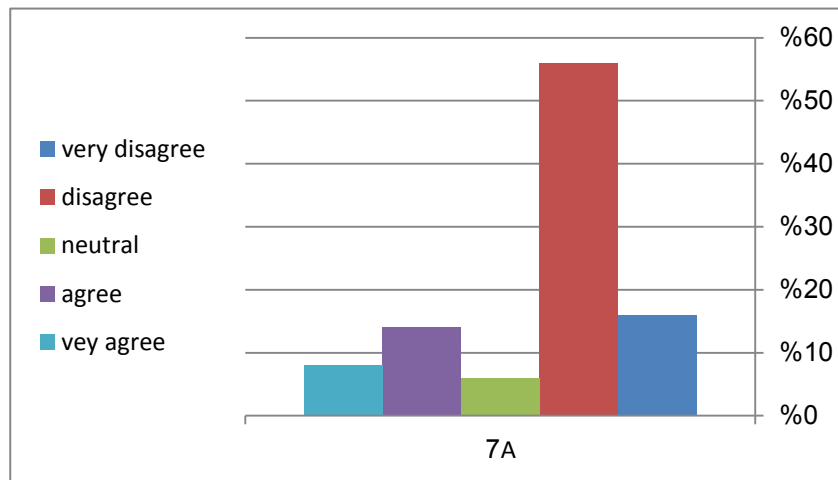

Figure (5-7)appointing a trained safety representative

8- With respect to the question of (A8) the respondents were asking (**we devoted adequate hours to train workers on safety means**), from their answers the analysis shows the main of **2.32**, which is less than the mean average (**3**), which is indicates that most firms doesn't aware about worker training which may lead to un safety performance and accidents that may leads to delays in work.

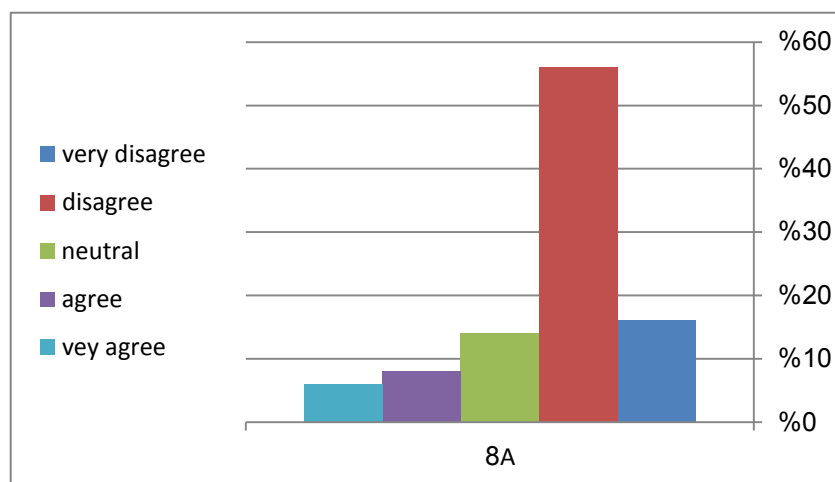

Figure (5-8)safety Training for workers

9- With respect to the question of (A9) the respondents were asking (**we put punishments for a workers who breaks safety regulations**), from their answers the analysis shows the main of **2.62**, which is less than the mean average (**3**), which is indicates that the respondents doesn't aware about workers punishment which may lead workers to break safety regulations without being afraid.

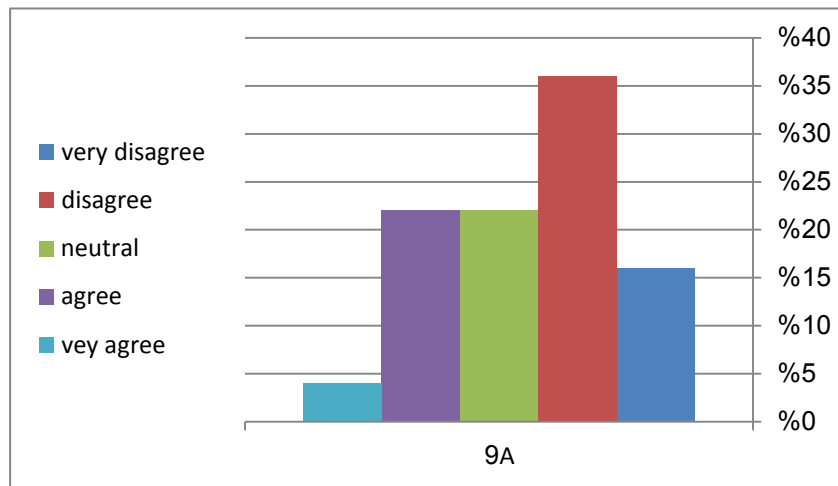

Figure (5-9)punishments and incentives

10- With respect to the question of (A10) the respondents were asking (**we allocate special places for worker’s to smoke on the site**), from their answers the analysis shows the main of **2.72**, which is less than the mean average (**3**), which is indicates that the respondents doesn't aware about allocating special places for smoking which may lead to un safety work and cause fire.

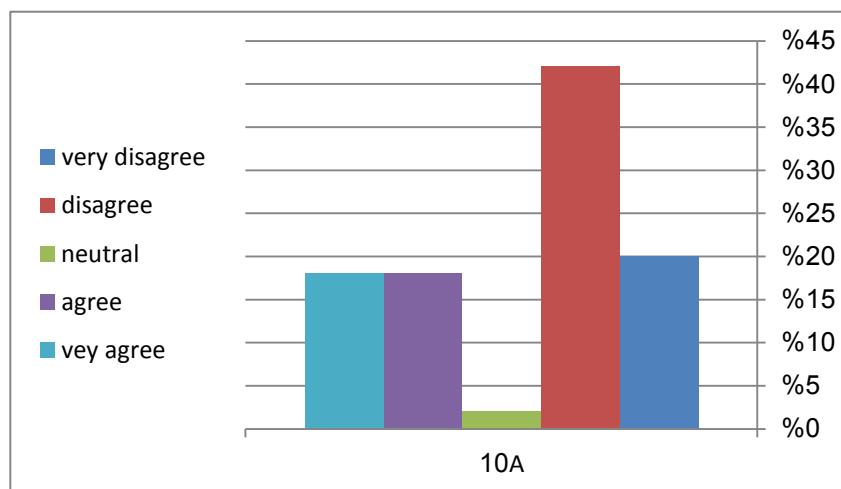

Figure (5-10)allocating special places for worker’s to smoke

11- With respect to the question of (A11) the respondents were asking (**we always correcting workers unsafe actions**), from their answers the analysis shows the main of **3.33**, which is greater than the mean average (**3**), which is indicates that the respondents doesn't mostly aware about correcting unsafe action that worker do and that lead workers to repeat these un safe actions which may leads to accidents.

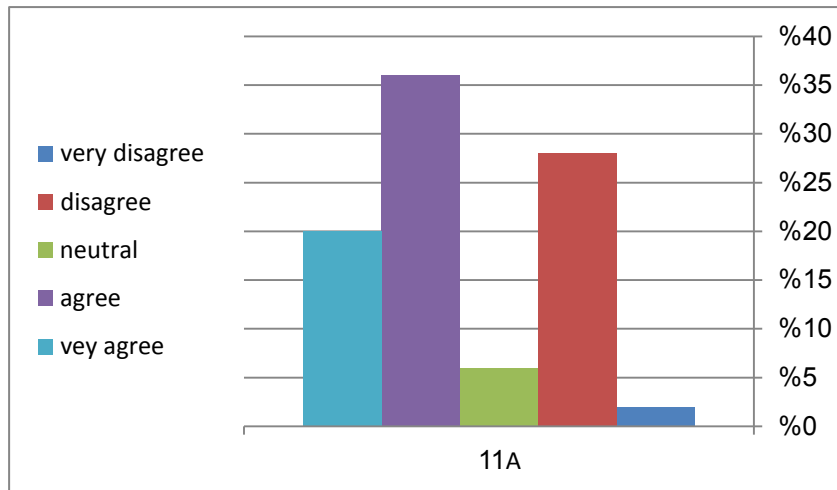

Figure (5-11) correcting workers unsafe actions

12- With respect to the question of (A12) the respondents were asking (**we insure our workers by company compensation insurance**), from their answers the analysis shows the main of **2.50**, which is less than the mean average (**3**), which is indicates that the respondents doesn't care about workers compensation insurance which may leads to legal problems and most respondent say that they doesn't insure their workers because they doesn't have a constant workers.

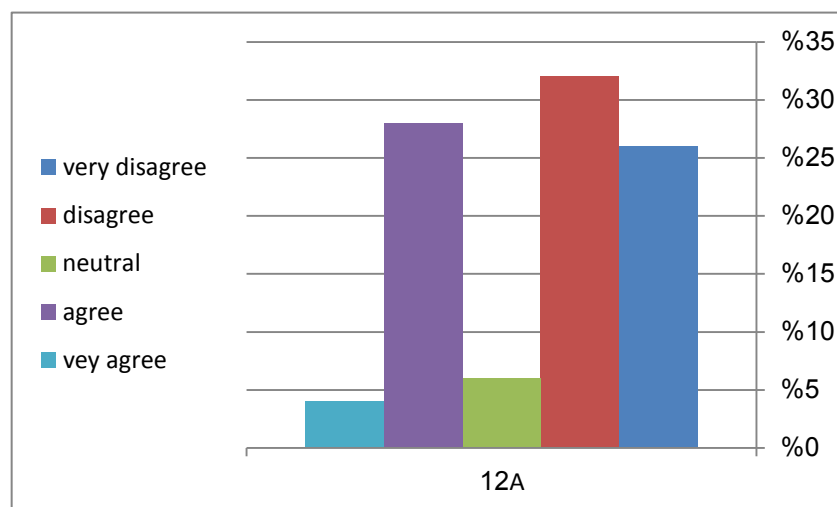

Figure (5-12) workers compensation insurance

13- With respect to the question of (A13) the respondents were asking (**The company is allocating amount of money from company capital for its attention to issues of occupational safety and health**), from their answers the analysis shows the main of **2.51**, which is less than the mean average (**3**), which is indicates that the most firms doesn't allocate amount of money to care about occupational safety and health.

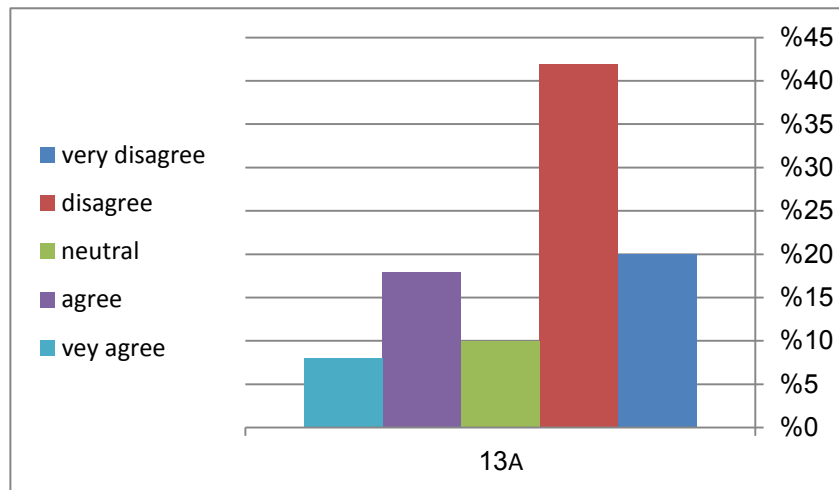

Figure (5-13) allocating amount of occupational safety and health issues

14- With respect to the question of (A14) the respondents were asking (**Our Safety Managers are trained in occupational safety**), from their answers the analysis shows the main of **2.84**, which is less than the mean average (**3**), which is indicates that the most firms doesn't care if there projects managers are trained or not.

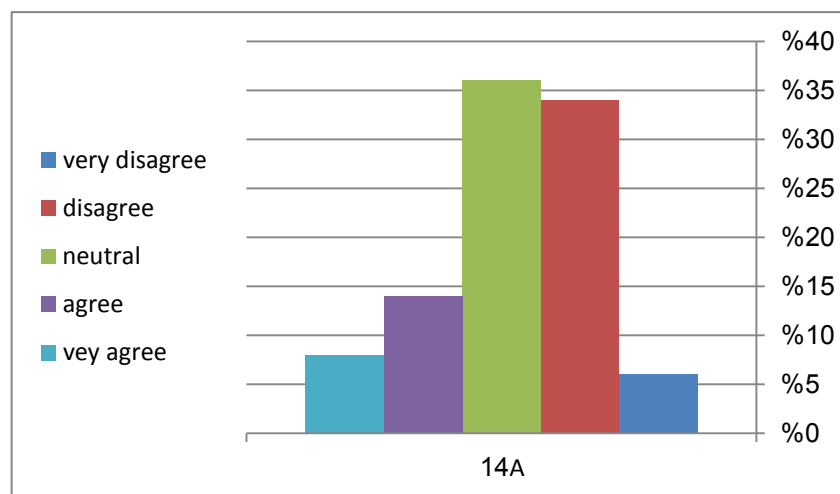

Figure (5-14) Trained safety manager

15- With respect to the question of (A15) the respondents were asking (**Increasing of the company volume will reduce its attention to the safety of workers**), from their answers the analysis shows the main of **2.63**, which is less than the mean average (**3**) which indicates that the most respondents see that the company volume doesn't reduce its attentions to safety of workers.

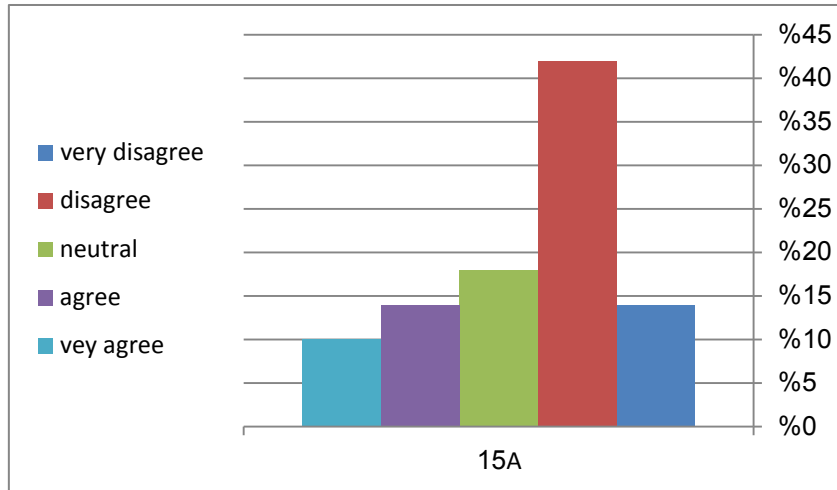

Figure (5-15) company volume and its effect on the safety of workers

16- With respect to the question of (A16) the respondents were asking (**We have department to monitor the Occupational Safety and Health**), from their answers the analysis shows the main of **2.49**, which is less than the mean average (**3**), which is indicates that the most firms doesn't care about devoting safety department to monitor Occupational Safety and Health issues that leads workers to work without regulations and that will also leads to un safety performance and many accidents which cause delays in works.

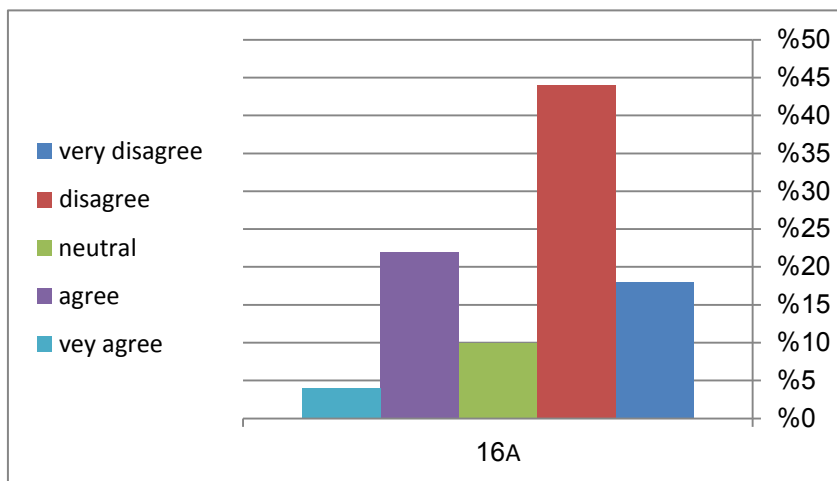

Figure (5-16)Existence of Safety department

17- With respect to the question of (A17) the respondents were asking (In the project planning step, we care about putting a clear plan for safety at construction sites), from their answers the analysis shows the main of 2.85 which is less than the mean average (3), which is indicates that the most firms doesn't careabout putting a clear plan for safety in project planning steps.

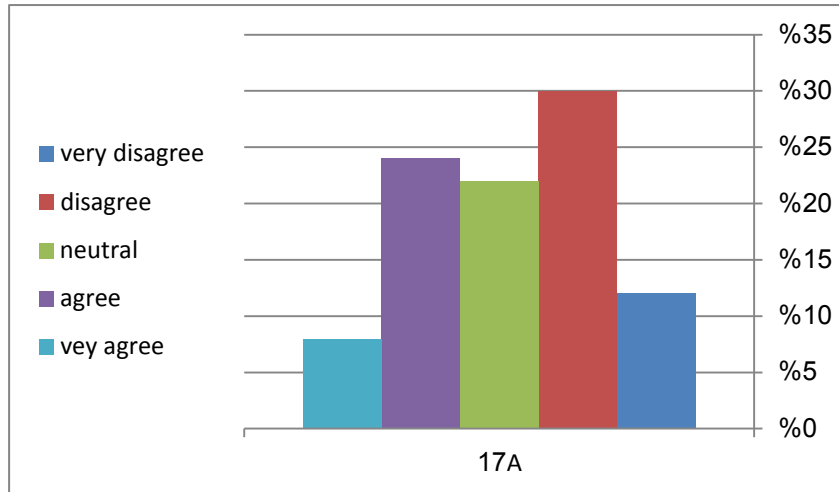

Figure (5-17) putting a clear plan for safety

18- With respect to the question of (A18) the respondents were asking (Putting regard to the safety issues in the tender stage may reduce the opportunities for competition), from their answers the analysis shows the main of 2.79 which is less than the mean average (3), which is indicates that the most respondent think that putting safety issues in their tender willnot reduce the oppourtunities for competition.

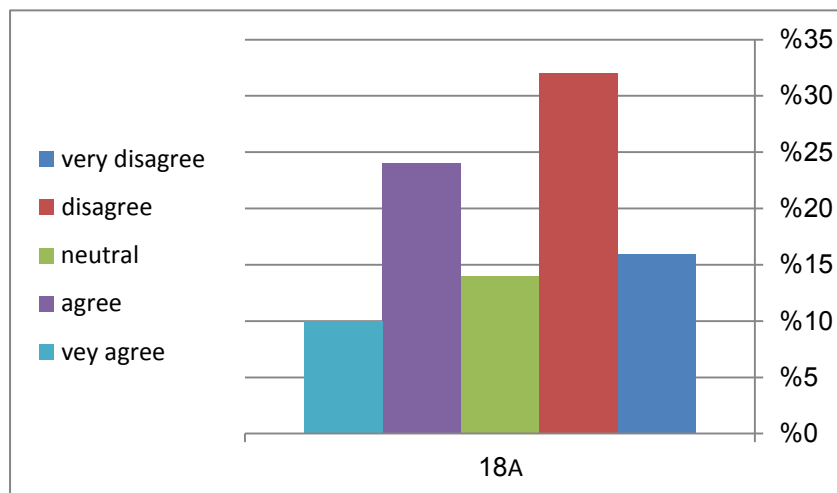

Figure (5-18) Putting regard to the safety issues in the tender

19- With respect to the question of (A19) the respondents were asking (**We discuss safety responsibilities with the owner and consultant**), from their answers the analysis shows the main of **2.86** which is less than the mean average (**3**), which is indicates that the most firms doesn't care about discussing safety responsibility with the project owners and consultants which may lead to problems because no one know his responsibility towards workers and work.

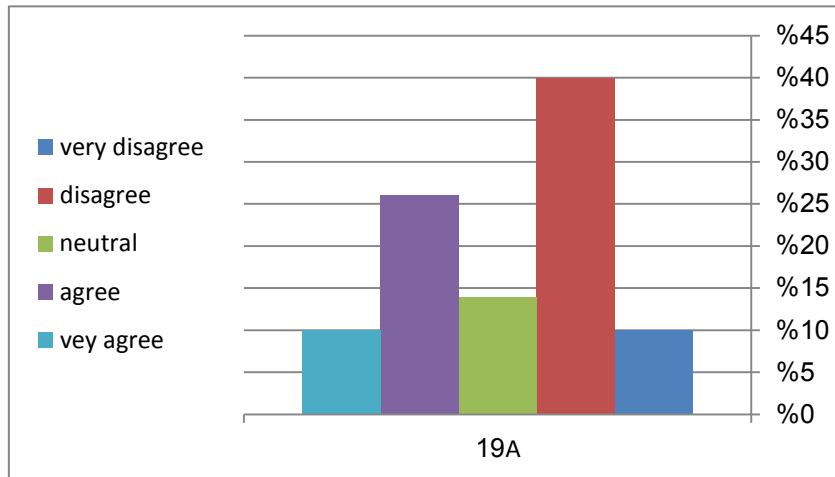

Figure (5-19)discussing safety responsibilities with the owner and consultant

20- With respect to the question of (A20) the respondents were asking (**We claim and ask Contractors to develop a plan for safety in projects at the tender stage**), from their answers the analysis shows the main of **2.64** which is less than the mean average (**3**), which is indicates that the most firms doesn't care about planning for safety at the tender stage, which is lead to un safety performance and financial problems.

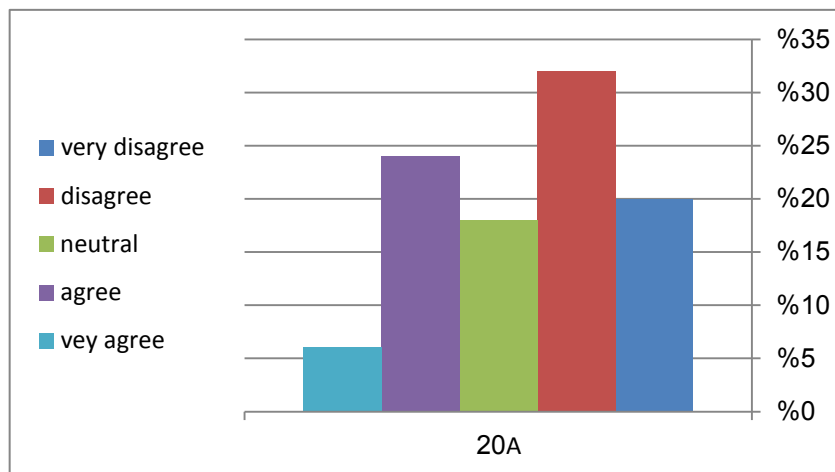

Figure (5-20)asking Contractors to develop a safety plan at the tender stage

### 5.3.1.1 Summary

With respect to the scale **A (Administrative factors)** the analysis shows the items A1 has the largest average **3.55** and the item A8 has the lowest average **2.32**. The general mean of the scale A is **2.73** which is little than the mean average **3** which indicates that most respondents doesn't have a proper planning and a good control by upper management to care about safety and most of their upper management doesn't put the safety issues as a priority.

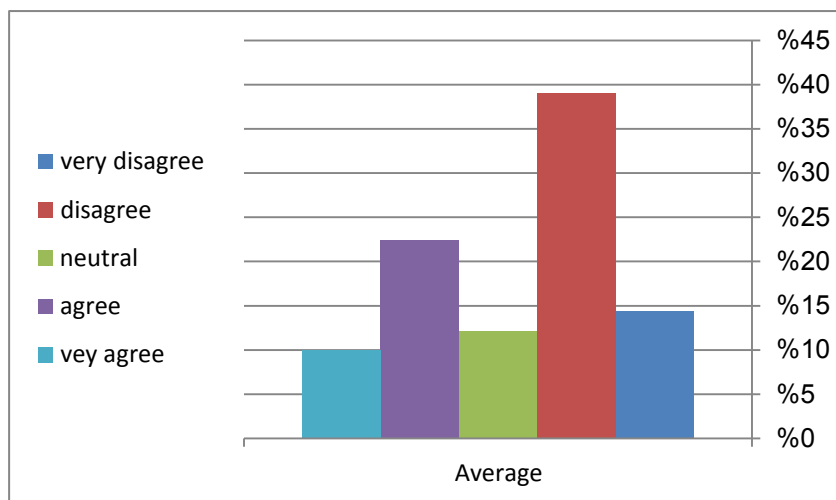

Figure (5-21) average of scale A (administrative factors)

### 5.3.2 Factors at Project Level

Table (5-2) the direction of respondents towards Factors at Project Steps:

Items	Means		1=very disagree	2= disagree	3= neutral	4= agree	5=very agree	SUM	Scale average
B1	3.90	f	1	6	2	29	12	50	3
		%	2	12	4	58	24	100	
B2	3.92	f	0	4	5	32	9	50	3
		%	0	8	10	64	18	100	
B3	3.49	f	0	10	10	24	5	49	3
		%	0	20	20	48	10	98	
B4	3.46	f	2	11	8	20	9	50	3
		%	4	22	16	40	18	100	
B5	3.72	f	0	6	10	26	8	50	3
		%	0	12	20	32	16	100	
B6	3.55	f	0	7	12	26	4	49	3
		%	0	14	24	32	8	98	
B7	3.79	f	0	8	4	26	10	48	3
		%	0	16	8	32	20	96	
SUM	25.83		3	52	51	183	57	346	
			6	104	102	366	114	692	
AVERAGE	3.69		0.43	7.43	7.29	26.14	8.14	49.43	
			0.86	14.86	14.57	52.28	16.28	98.86	
B8	3.72	f	0	10	4	26	10	50	3
		%	0	20	8	32	20	100	
B9	3.74	f	0	7	7	28	8	50	3
		%	0	14	14	56	16	100	
B10	3.16	f	3	16	6	18	6	49	3
		%	6	32	12	36	12	100	
B11	3.80	f	0	8	5	26	11	50	3
		%	0	16	10	32	22	100	
SUM	14.42		3	41	22	98	35	199	
			6	82	44	196	70	398	
AVERAGE	3.60		0.75	10.25	5.5	24.5	8.75	49.75	
			1.5	20.5	11	49	17.5	99.5	
B12	3.26	f	2	14	8	21	5	50	3
		%	4	28	16	42	10	100	
B13	2.82	f	4	21	7	16	2	50	3
		%	8	42	14	32	4	100	
B14	3.48	f	1	12	4	28	5	50	3
		%	2	24	8	56	10	100	
B15	3.62	f	1	9	6	26	8	50	3
		%	2	18	12	52	16	100	
B16	3.60	f	0	10	8	24	8	50	3
		%	0	20	16	48	16	100	
SUM	16.78		8	66	33	115	28	250	
			16	132	66	230	56	500	
AVERAGE	3.36		1.6	13.2	6.6	23	5.6	50	
			3.2	26.4	13.2	46	11.2	100	

B17	2.85	f	6	15	11	12	4	48	3
		%	12	30	22	24	8	96	
B18	2.79	f	8	16	7	12	5	50	3
		%	16	32	14	24	10	100	
<b>SUM</b>	5.64		14	31	18	24	9	98	
			28	62	36	48	18	196	
<b>AVERAGE</b>	2.82		7	15.5	9	12	4.5	49	
			14	31	18	24	9	98	
B19	3.52	f	0	10	12	20	8	50	3
		%	0	20	24	40	16	100	
B20	2.76	f	7	19	8	11	5	50	3
		%	14	38	16	22	10	100	
B21	2.86	f	9	15	6	12	7	49	3
		%	18	30	12	24	14	98	
<b>SUM</b>	9.14		16	44	26	43	20	149	
			32	88	52	86	40	298	
<b>AVERAGE</b>	3.05		5.33	14.67	8.67	14.33	6.67	49.67	
			10.67	29.33	17.33	28.67	13.33	99.33	
B22	3.43	f	5	8	6	21	9	49	3
		%	10	16	12	42	18	98	
B23	3.16	f	4	12	11	18	5	50	3
		%	8	24	22	36	10	100	
B24	2.56	f	8	21	7	13	1	50	3
		%	16	42	14	26	2	100	
<b>SUM</b>	9.15		17	41	24	52	15	149	
			34	82	48	104	30	298	
<b>AVERAGE</b>	3.05		5.67	13.67	8	17.33	5	49.67	
			11.33	27.33	16	34.67	10	99.33	
B25	3.50	f	2	8	7	26	5	48	3
		%	4	16	14	52	10	96	
B26	3.78	f	1	4	5	34	5	49	3
		%	2	8	10	68	10	98	
B27	2.61	f	8	18	11	9	3	49	3
		%	16	36	22	18	6	98	
<b>SUM</b>	9.89		11	30	23	69	13	146	
			22	60	46	138	26	292	
<b>AVERAGE</b>	3.30		3.67	10	7.67	23	4.33	48.67	
			7.33	20	15.33	46	8.67	97.33	
B28	2.48	f	10	21	7	9	3	50	3
		%	20	42	14	18	6	100	
B29	3.29	f	3	13	7	19	7	49	3
		%	6	26	14	38	14	98	
B30	3.30	f	2	13	10	18	7	50	3
		%	4	26	20	36	14	100	
<b>SUM</b>	9.07		15	47	24	46	17	149	
			30	94	48	92	34	298	
<b>AVERAGE</b>	3.02		5	15.67	8	15.3	5.67	49.67	
			10	31.33	16	30.67	11.33	99.33	
B31	3.58	f	-	10	8	22	8	48	3
		%	-	20	16	44	16	96	

B32	3.52	f	1	11	7	23	8	50	3
		%	2	22	14	46	16	100	
B33	3.52	f	2	9	9	21	9	50	3
		%	4	18	18	42	18	100	
B34	3.04	f	5	12	12	16	4	49	3
		%	10	24	24	32	8	98	
B35	3.54	f	-	7	15	22	6	50	3
		%	-	14	30	44	12	100	
<b>SUM</b>	17.2		8	49	51	104	35	247	
			16	98	102	208	70	494	
<b>AVERAGE</b>	3.44		1.6	9.8	10.2	20.8	7	49.4	
			3.2	19.6	20.4	41.6	14	98.8	
B36	2.70	f	8	16	13	9	4	50	3
		%	16	32	26	18	8	100	
B37	2.62	f	8	22	5	11	4	50	3
		%	16	44	10	22	8	100	
B38	3.04	f	7	15	6	13	9	50	3
		%	14	30	12	26	18	100	
B39	3.08	f	3	19	5	17	6	50	3
		%	6	38	10	34	12	100	
B40	3.4	f	2	14	5	17	10	48	3
		%	4	28	10	34	20	96	
<b>SUM</b>	14.84		28	86	34	67	33	248	
			56	172	68	134	66	496	
<b>AVERAGE</b>	2.97		5.6	17.2	6.8	13.4	6.6	49.6	
			11.2	34.4	13.6	26.8	13.2	99.2	
B41	3.29	f	3	11	10	19	6	49	3
		%	6	22	20	38	12	98	
B42	3.48	f	2	6	14	22	6	50	3
		%	4	12	28	44	12	100	
B43	3.88	f	-	3	11	25	11	50	3
		%	-	6	22	50	22	100	
B44	3.12	f	4	11	12	21	2	50	3
		%	8	22	24	42	4	100	
B45	2.96	F	2	17	14	15	2	50	3
		%	4	34	28	30	4	100	
<b>SUM</b>	16.73	F	11	48	61	102	27	249	
		%	22	96	122	204	54	498	
<b>AVERAGE</b>	3.35	f	2.2	9.6	12.2	20.4	5.4	49.8	
		%	4.4	19.2	24.4	40.8	10.8	99.6	
B46	3.25	F	3	12	9	18	6	48	3
		%	6	24	18	36	12	96	
B47	3.02	F	4	17	7	16	5	49	3
		%	8	34	14	32	10	98	
<b>SUM</b>	6.27	F	7	29	16	34	11	97	
		%	14	58	32	68	22	194	
<b>AVERAGE</b>	3.12	F	3.5	14.5	8	17	5.5	48.5	
		%	7	29	16	34	11	97	
B48	2.96	f	6	16	7	14	6	49	3
		%	12	32	14	28	12	98	

B49	3.06	f	4	17	6	16	6	49	3
		%	8	34	12	32	12	98	
B50	2.96	f	4	20	9	6	10	49	3
		%	8	40	18	12	20	98	
B51	3.52	f	3	10	7	18	12	50	3
		%	6	20	14	36	24	100	
B52	3.04	f	3	19	9	9	9	49	3
		%	6	38	18	18	18	98	
<b>SUM</b>	15.54	f	20	82	35	63	43	246	
		%	40	164	70	126	86	492	
<b>AVERAGE</b>	3.11	f	4	16.4	7	12.6	8.6	49.2	
		%	8	32.8	14	25.2	17.2	98.4	
B53	2.35	f	11	21	6	8	2	48	3
		%	22	42	12	16	4	96	
B54	2.56	f	7	20	10	9	2	48	3
		%	14	40	20	18	4	96	
<b>SUM</b>	4.91	f	18	43	16	17	4	96	
			36	86	32	34	8	192	
<b>AVERAGE</b>	2.45	f	9	21.5	8	8.5	2	48	
		%	18	43	16	17	4	96	
B55	2.61	f	8	21	6	10	4	49	3
		%	16	42	12	20	8	98	
B56	2.57	f	9	19	8	10	3	49	3
		%	18	38	16	20	6	98	
B57	2.98	f	4	19	6	16	5	50	3
		%	8	38	12	32	10	100	
<b>SUM</b>	8.16	f	21	59	20	36	12	148	
		%	42	118	40	72	24	296	
<b>AVERAGE</b>	2.72	f	7	19.67	6.67	12	4	49.3	
		%	14	39.3	13.3	24	8	98.67	
<b>SUM</b>	183.21	f	200	748	454	1053	359	2799	
		%	400	1496	908	2106	718	5598	
<b>AVERAGE</b>	3.21	f	3.51	13.12	7.96	18.47	6.29	49.10	
		%	7.01	26.24	15.92	36.94	12.59	98.21	

Source: Field survey

- 1- With respect to the question of **(B1)** the respondents were asking **(We protect the public from risks which they may exposed to it by fencing off the working area)**, from their answers the analysis shows the main of **3.90**, which is greater than the mean average **(3)**, which indicates that the most respondents fence the working area to protect the public from risks and for protecting their materials from being stolen.

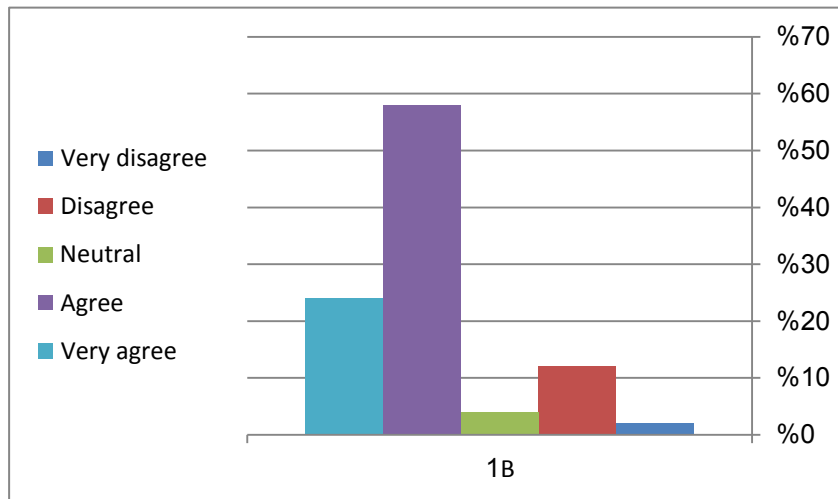

Figure (5-22) fencing off the working area

- 2- With respect to the question of **(B2)** the respondents were asking **(When work finishes, we make sure that Site entrances are secured )**, from their answers the analysis shows the main of **3.92**, which is greater than the mean average **(3)**, which indicates that the most of the respondents secured the site entrances before they leaving it .

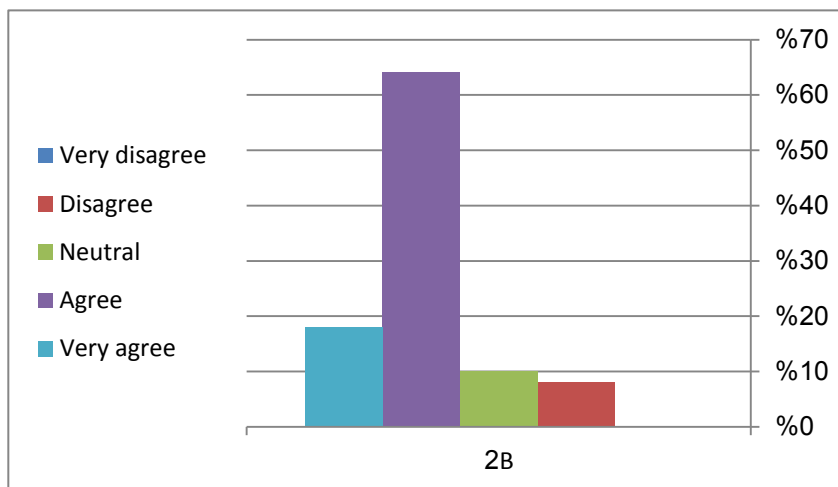

Figure (5-23) securing Site entrances when work finishes

- 3- With respect to the question of **(B3)** the respondents were asking **(When work finishes, we make sure that the fence Perimeter is intact and functional)**, from their answers the analysis shows the main of **3.49**, which is greater than the mean average (**3**), which indicates that the respondents make checks if the fence Perimeters intact and functional .

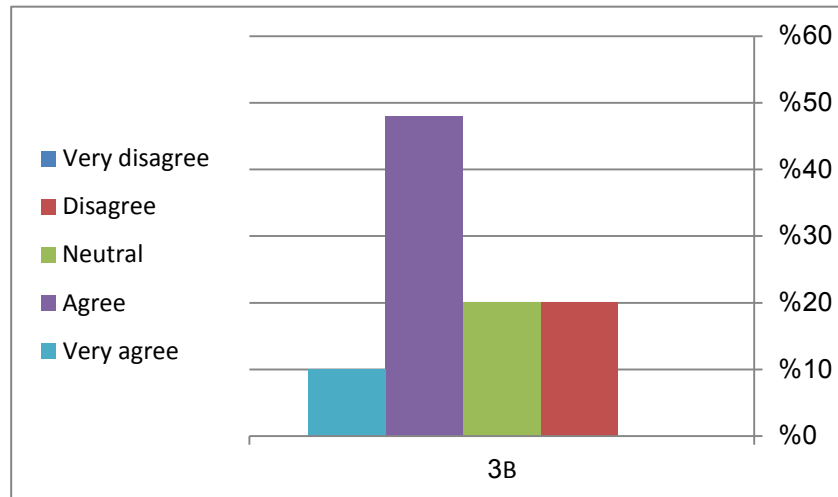

Figure (5-24) the work site fence Perimeter is intact and functional

- 4- With respect to the question of **(B4)** the respondents were asking **(When work finishes, we make sure that Flooded areas, excavations and openings are covered or protected by barriers)**, from their answers the analysis shows the main of **3.46**, which is greater than the mean average (**3**), which indicates that the respondents didn't mostly check if Flooded areas, excavations, openings are covered or protected by barriers.

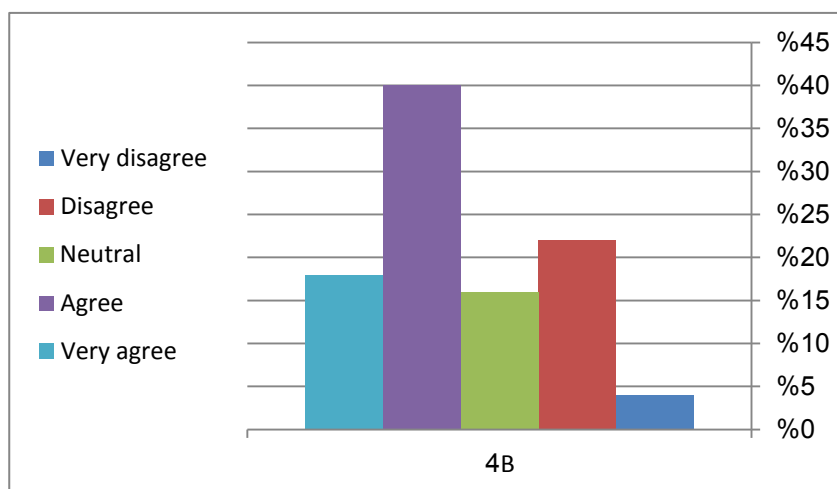

Figure (5-25) covering flooded areas, excavations and openings and protect them with barriers

5- With respect to the question of **(B5)** the respondents were asking **(When work finishes, we make sure that all site plant and remaining vehicles are immobilized)**, from their answers the analysis shows the main of **3.72**, which is greater than the mean average **(3)**, which indicates that the respondents check if all site plant and remaining vehicles are immobilized .

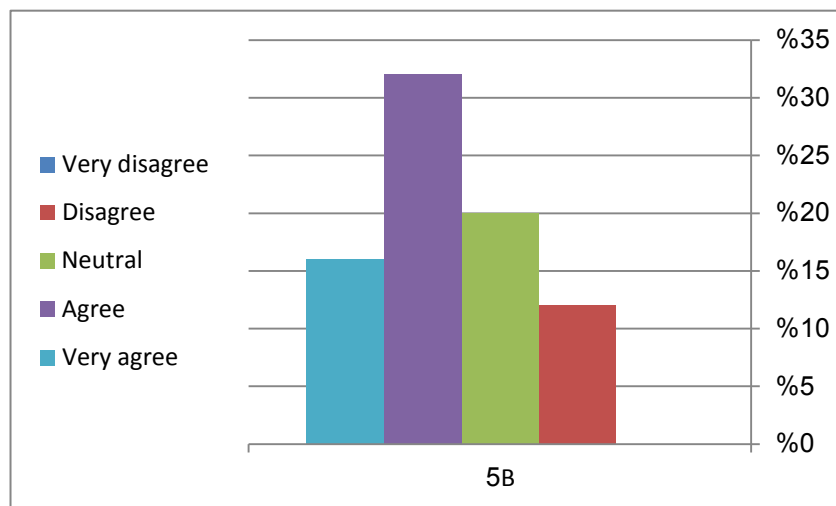

Figure (5-26) making sure that all site plant and remaining vehicles are immobilized after the work finish

6- With respect to the question of **(B6)** the respondents were asking **(When work finishes, we make sure that the access to scaffolding is removed or blocked)**, from their answers the analysis shows the main of **3.55**, which is greater than the mean average **(3)**, which indicates that the respondents check if the access to scaffolding is removed or blocked.

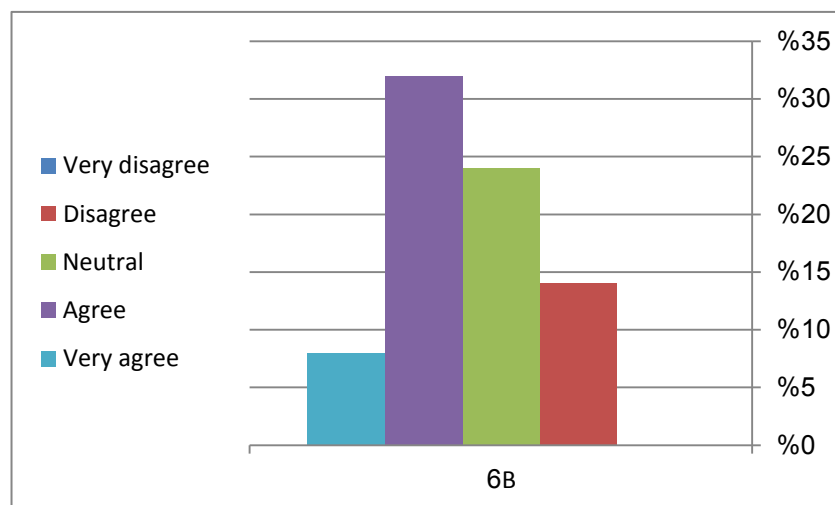

Figure (5-27) securing that the access to scaffolding

7- With respect to the question of **(B7)** the respondents were asking **(When work finishes, we make sure that the all piled and stacked materials is safe)**, from their answers the analysis shows the main of **3.79**, which is greater than the mean average (**3**), which indicates that the respondents make sure that the all piled and stacked materials is safe before they leaving the working site.

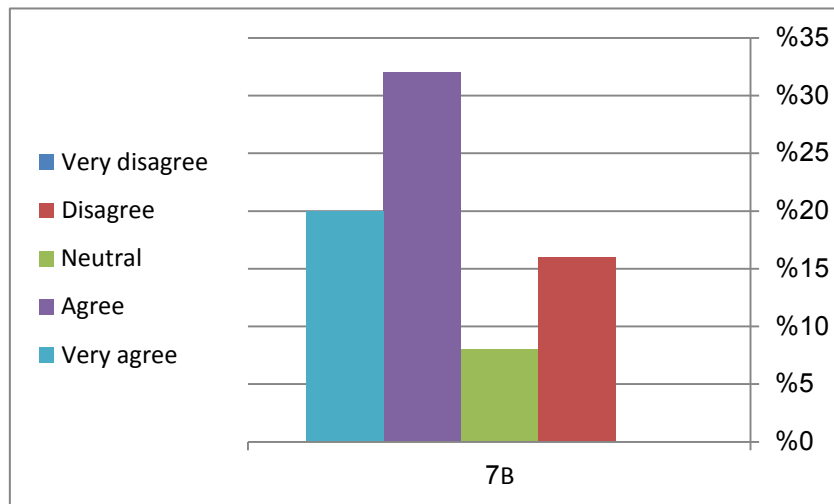

Figure (5-28) securing all piled and stacked materials

### 5.3.2.1 Summary of (Public protection)

With respect to the scale **B (Public protection)** the analysis shows the items B2 has the largest average **3.92** and the item B4 has the lowest average **3.46**. The general mean of this section is **3.69** which is greater than the mean average **3** which indicates that most respondents care about fencing the working site and make care about public but, most respondents fence the site and make sure that the entrances are secured to protect their material from being stolen.

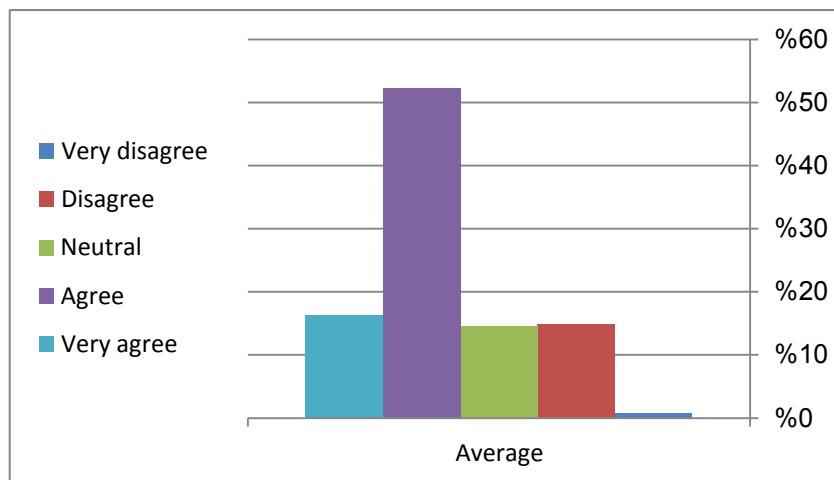

Figure (5-29) average for (public protection)

8- With respect to the question of **(B8)** the respondents were asking **(we make sure that all structures being worked on stable, safe and not overloaded)**, from their answers the analysis shows the main of **3.72**, which is greater than the mean average (**3**), which indicates that the respondents make sure that Are all structures being worked on stable, safe and not overloaded.

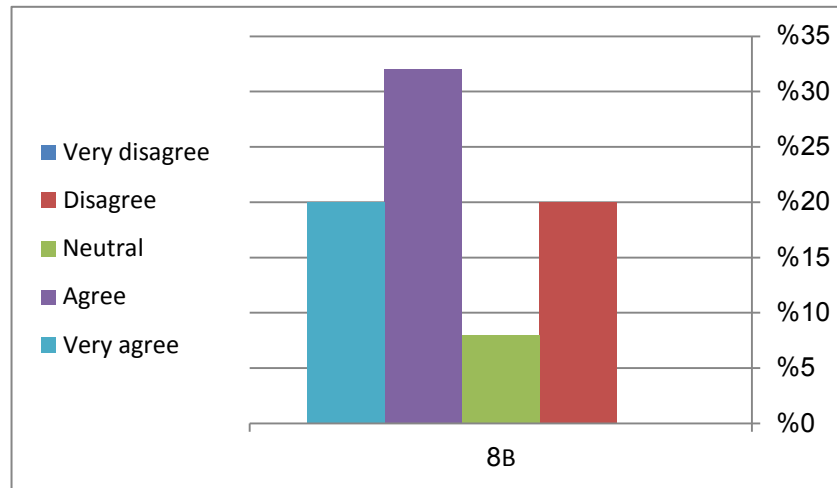

Figure (5-30)all structures are stable, safe and not overloaded

9- With respect to the question of **(B9)** the respondents were asking **(we make sure that the site is tidy and meeting an acceptable standard of housekeeping)**, from their answers the analysis shows the main of **3.74**, which is greater than the mean average (**3**), which indicates that the respondents sometimes care about the site if it is tidy and meeting an acceptable standard of housekeeping.

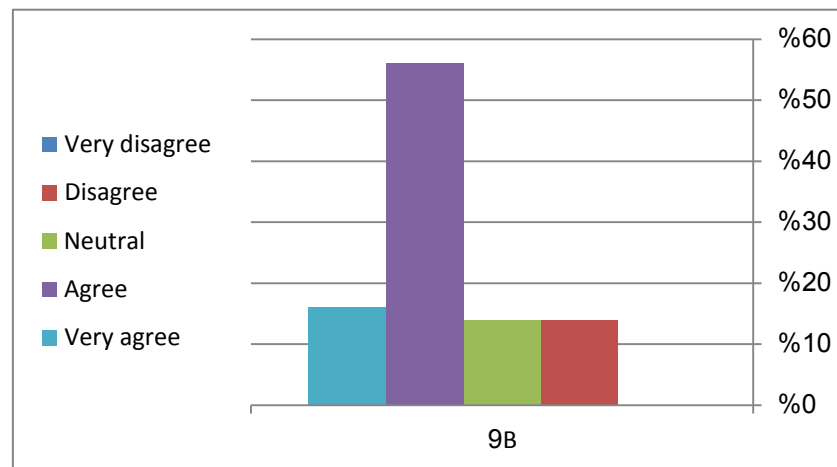

Figure (5-31) keeping the site tidy and meeting an acceptable standard of housekeeping

10- With respect to the question of **(B10)** the respondents were asking **(we organize the operation of collecting and disposing of waste regularly)**, from their answers the analysis shows the main of **3.16**, which is little greater than the mean average **(3)**, which indicates that the respondents didn't mostly care about collecting and disposing of waste regularly.

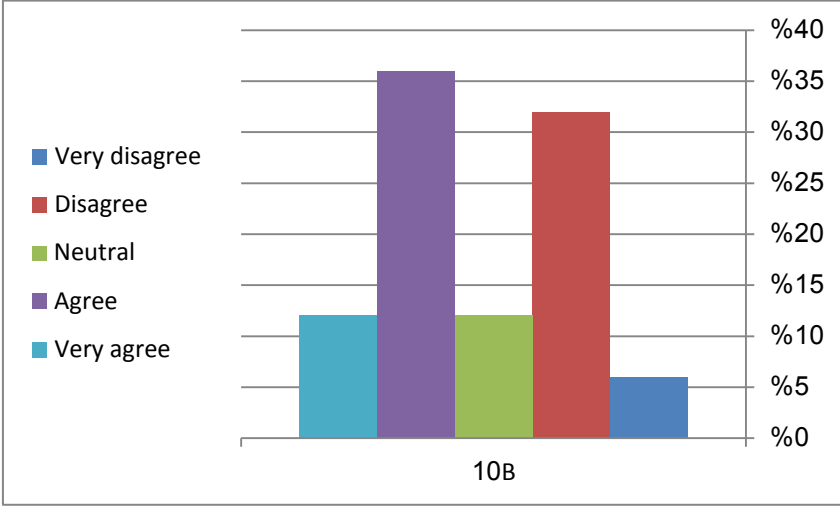

Figure (5-32) collecting and disposing of waste regularly

11- With respect to the question of **(B11)** the respondents were asking **(We offer adequate lighting in main and common areas, in addition to task lighting)**, from their answers the analysis shows the main of **3.80**, which is greater than the mean average **(3)**, which indicates that the respondents offer adequate lighting In the night-time hours of work.

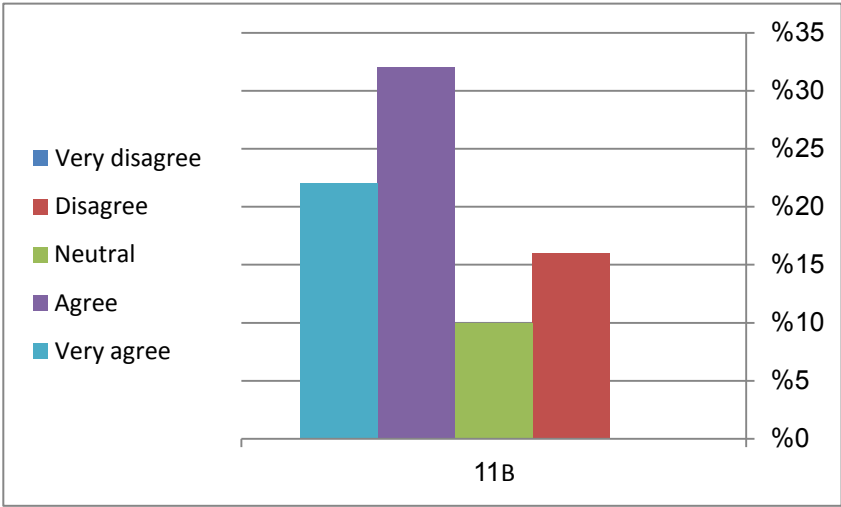

Figure (5-33) adequate lighting in main and common areas

### 5.3.2.2 Summary of (Safe access)

With respect to the scale **B (Safe access)** the analysis shows the items B11 has the largest average **3.80** and the item B10 has the lowest average **3.16**. The general mean of this section is **3.60** which is greater than the mean average **3** which indicates that most respondents care about safe access and they try to keep the site clean and tidy.

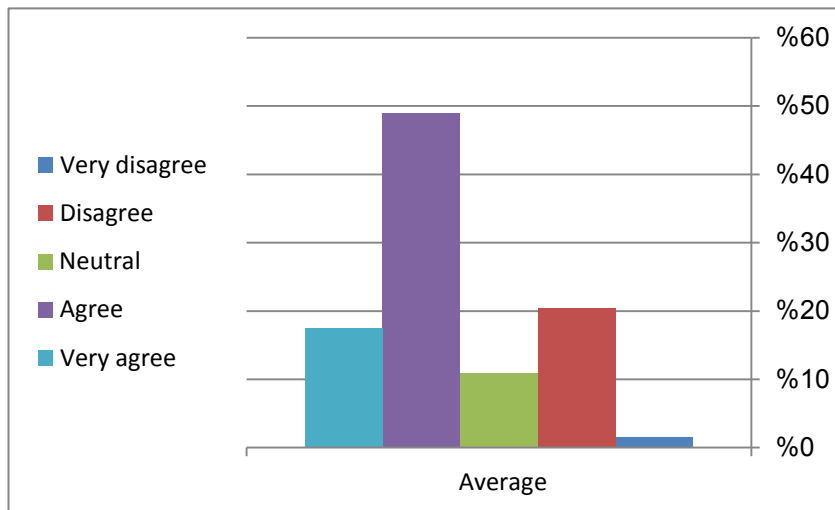

Figure (5-34) average of (safe access)

12- With respect to the question of **(B12)** the respondents were asking **(we regularly make checks to ensure that scaffolds are only erected and altered by competent persons and the safe access available to platform levels in all cases)**, from their answers the analysis shows the main of **3.26**, which is little greater than the mean average (**3**), which indicates that the respondents didn't mostly makes checks for scaffolds to ensure if it is safety to work in it or not.

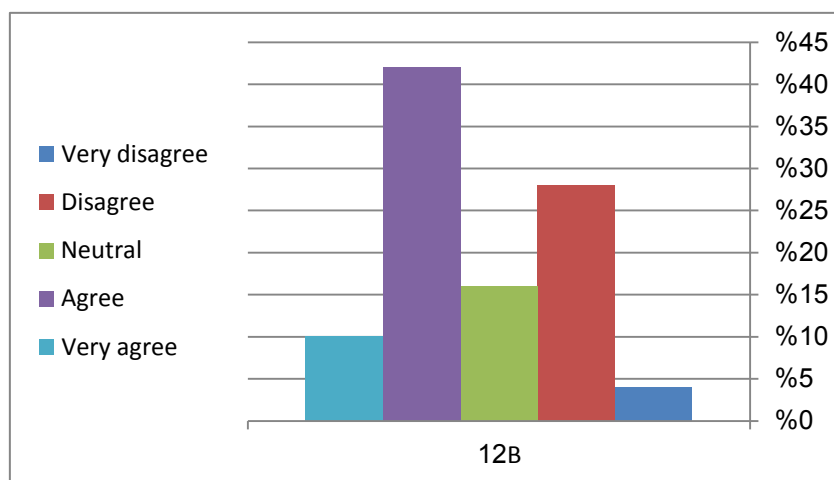

Figure (5-35) scaffolds are erected and altered by competent persons and the safe access available to platform levels

13- With respect to the question of **(B13)** the respondents were asking **(we make sure that all scaffolds inspected at least weekly by a competent person and the results recorded, and always following substantial alteration or damage)**, from their answers the analysis shows the main of **2.82**, which is less than the mean average (**3**), which indicates that the respondents didn't care about scaffolds inspections and they doesn't make checks to it by competent person.

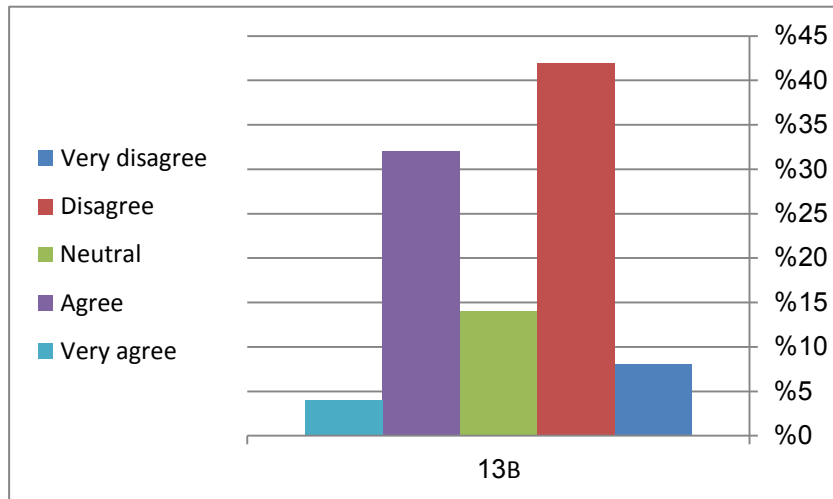

Figure (5-36) scaffolds are inspected at least weekly by a competent person

14- With respect to the question of **(B14)** the respondents were asking **(we make sure that all scaffold bracing and support members in place)**, from their answers the analysis shows the main of **3.48**, which is greater than the mean average (**3**), which indicates that the respondents care about if scaffolds bracing and support members in place to save workers from falling and that may leads to a lot of accidents and fatal injuries.

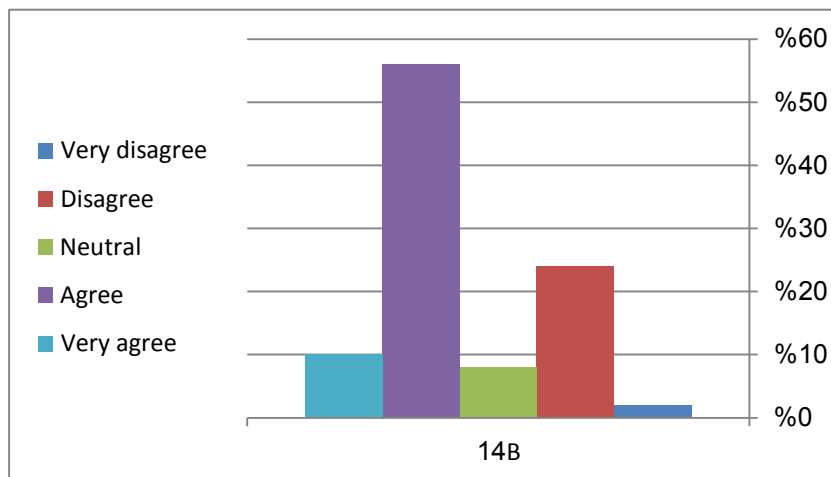

Figure (5-37) all scaffold bracing and support members in place

15- With respect to the question of **(B15)** the respondents were asking **(we make sure that all scaffolds appropriately braced or secured to structure appropriately to prevent collapse)**, from their answers the analysis shows the main of **3.62**, which is greater than the mean average **(3)**, which indicates that the respondents care about if scaffolds are appropriately braced or secured to structure appropriately to prevent collapse.

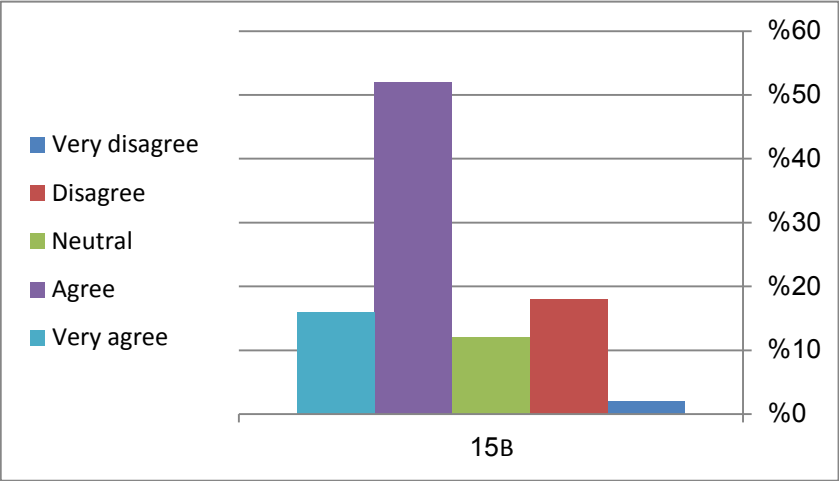

Figure (5-38) all scaffolds appropriately braced or secured to structure appropriately

16- With respect to the question of **(B16)** the respondents were asking **(we make sure that the stored materials evenly distributed on the scaffold platforms and not excessive)**, from their answers the analysis shows the main of **3.60**, which is greater than the mean average **(3)**, which indicates that the respondents care about stored materials evenly distributed on the scaffold platforms and not excessive.

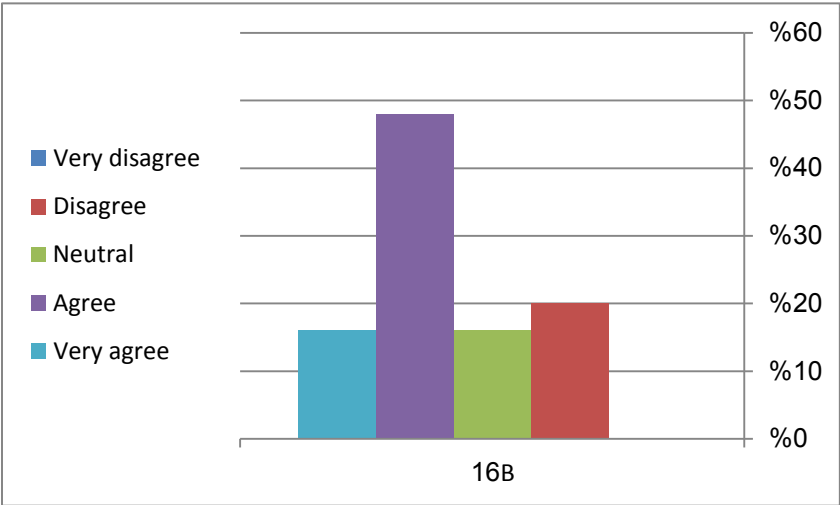

Figure (5-39) stored materials evenly distributed on the scaffold platforms and not excessive

### 5.3.2.3 Summary of (Scaffolds)

With respect to the scale **B (Scaffolds)** the analysis shows the items **B15** has the largest average **3.62** and the item **B13** has the lowest average **2.82**. The general mean of this section is **3.36** which is greater than the mean average **3** which indicates that the respondents direct to get little improvement in erecting, altering and inspecting the scaffolds.

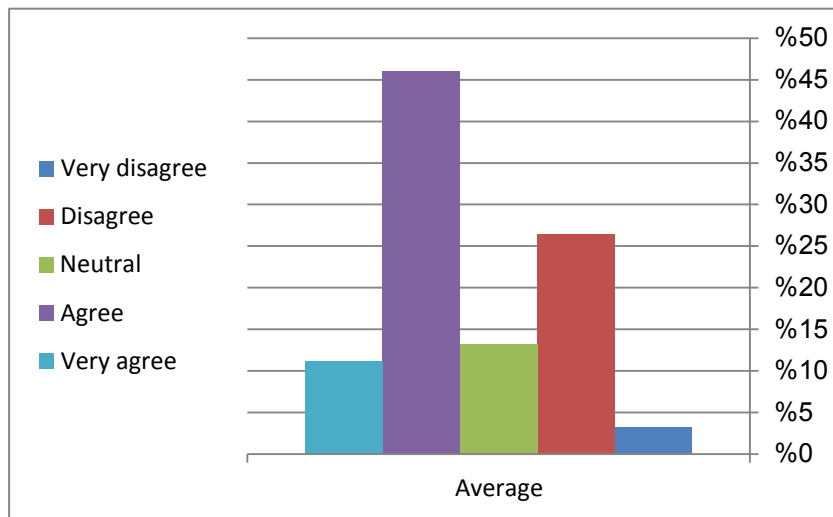

Figure (5-40) average of (scaffolds)

17- With respect to the question of **(B17)** the respondents were asking **(we make sure that the ladders checked for defects before use and in a good condition )**, from their answers the analysis shows the main of **2.85**, which is less than the mean average **(3)**, which indicates that the respondents didn't care about checking the ladders before using.

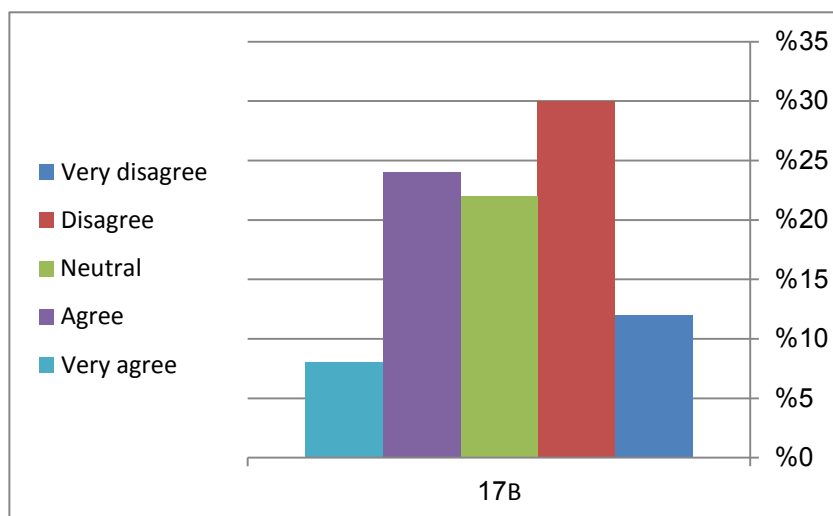

Figure (5-41) the ladders checked for defects before use

18- With respect to the question of **(B18)** the respondents were asking **(we make sure that the ladders secured before use to prevent slipping)**, from their answers the analysis shows the main of **2.79**, which is less than the mean average **(3)**, which indicates that the respondents didn't care about checking the ladders before using to prevent slipping .

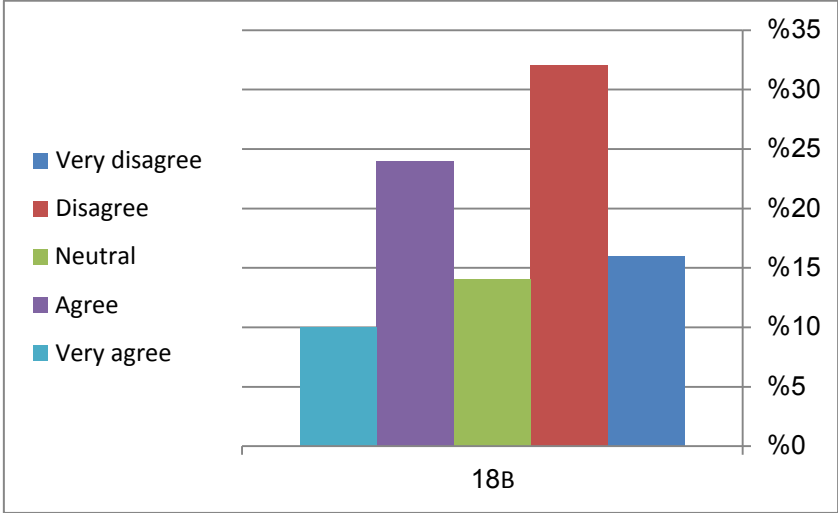

Figure (5-42) securing the ladders before use to prevent slipping

**5.3.2.4 Summary (Ladders and stepladders)**

With respect to the scale **B (Ladders and stepladders)** the analysis shows the general mean of this section is **2.82** which is less than the mean average **3** which indicates that the respondents doesn't care about ladders in the work site and that will may leads to a lot of accidents such as slipping and fractures.

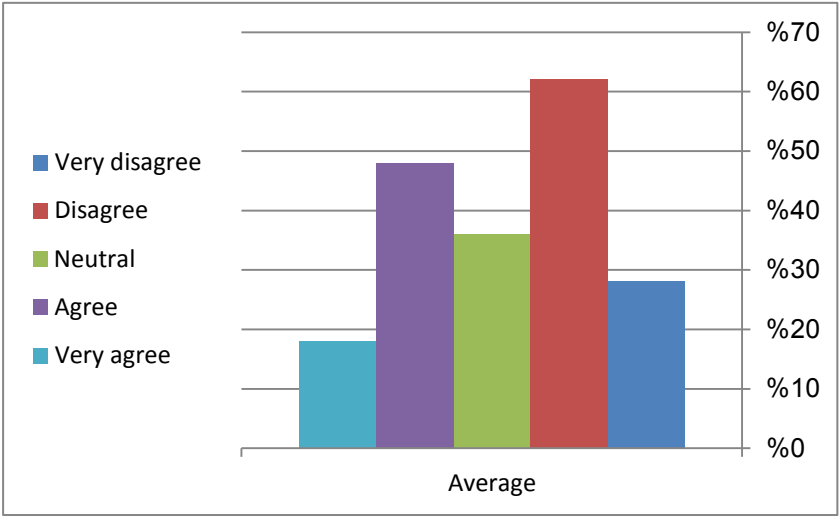

Figure (5-43) average of (ladders and stepladders)

19- With respect to the question of **(B19)** the respondents were asking **(we make sure that the equipment properly erected by competent person to comply with suppliers' instruction)**, from their answers the analysis shows the main of **3.52**, which is greater than the mean average (**3**), which indicates that the respondents care about checking if the equipment properly erected by competent person to comply with suppliers' instruction.

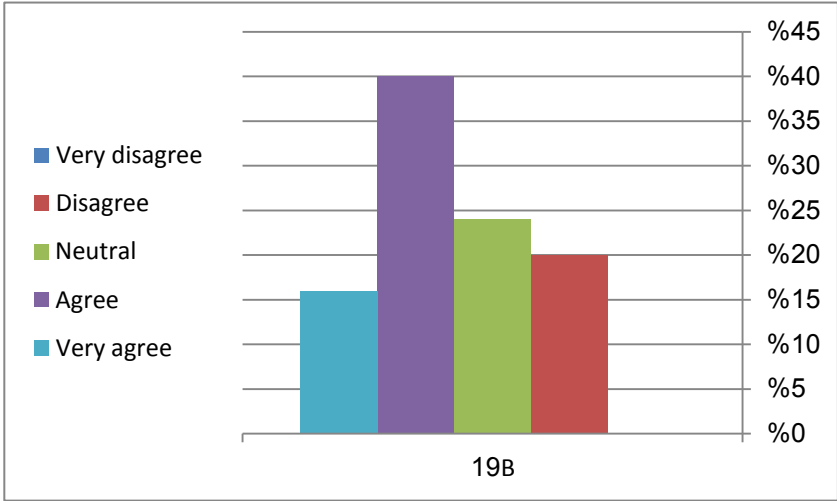

Figure (5-44)the equipment properly erected by competent person

20- With respect to the question of **(B20)** the respondents were asking **(We train the operators of the machinery and equipment)**, from their answers the analysis shows the main of **2.76**, which is greater than the mean average (**3**), which indicates that the respondents didn't care about checking if the equipment properly erected by competent person to comply with suppliers' instruction.

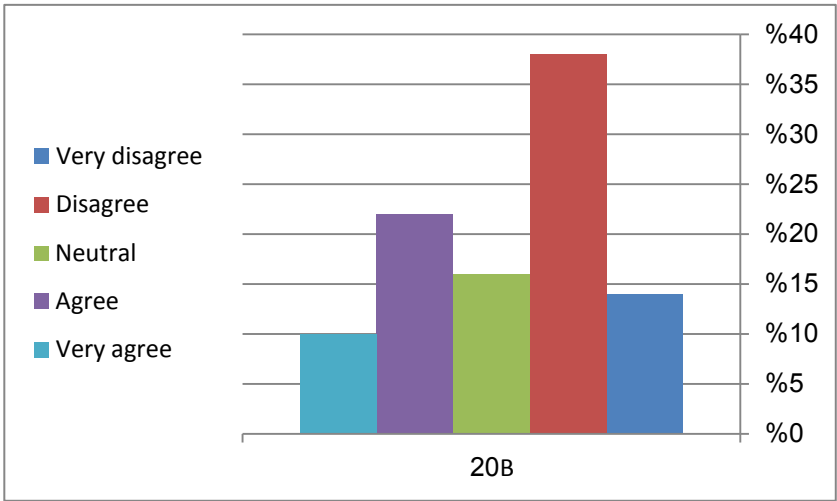

Figure (5-45) training the operators of the machinery and equipment

21- With respect to the question of **(B21)** the respondents were asking **(we commit our workers to wear Helmet protection)**, from their answers the analysis shows the main of **2.86**, which is less than the mean average **(3)**, which indicates that the respondents didn't force their workers to wear Helmet protection while they work which may expose them to fatal risk.

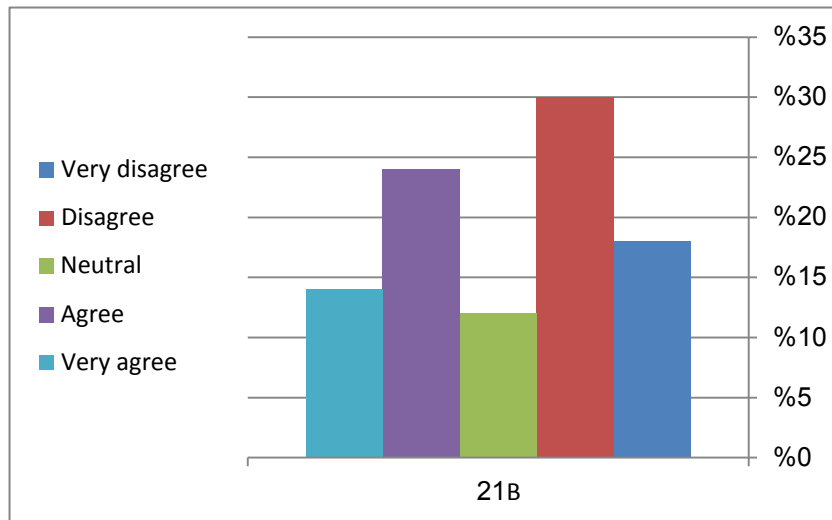

Figure (5-46) Forcing workers to wear protective

### 5.3.2.5 Summary of (Power access equipment)

With respect to the scale **B (Power access equipment)** the analysis shows the items **B19** has the largest average **3.52** and the item **B20** has the lowest average **2.76**. The general mean of this section is **3.05** which is closed to the mean average **3** which indicates that the respondents doesn't mostly aware about working at Power access equipment and they doesn't commit worker to wear a helmet protection.

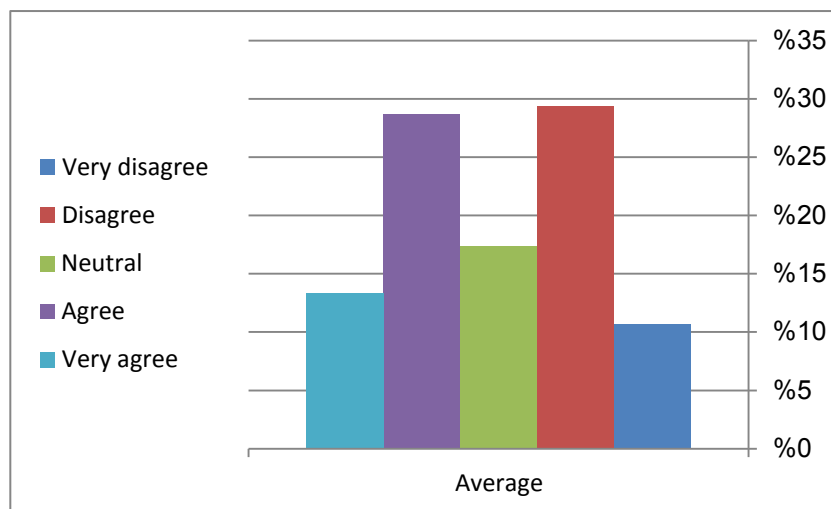

Figure (5-47) average of (Power access equipment)

22- With respect to the question of **(B22)** the respondents were asking **(Have all cranes operators been specifically instructed in the identification of weight and center of gravity before lifting a load?)**, from their answers the analysis shows the main of **3.43**, which is greater than the mean average (**3**), which indicates that the most cranes operators know the cranes design load and the slingers know the center of gravity before lifting a load and that may prevent a lot of problems such material falling in people.

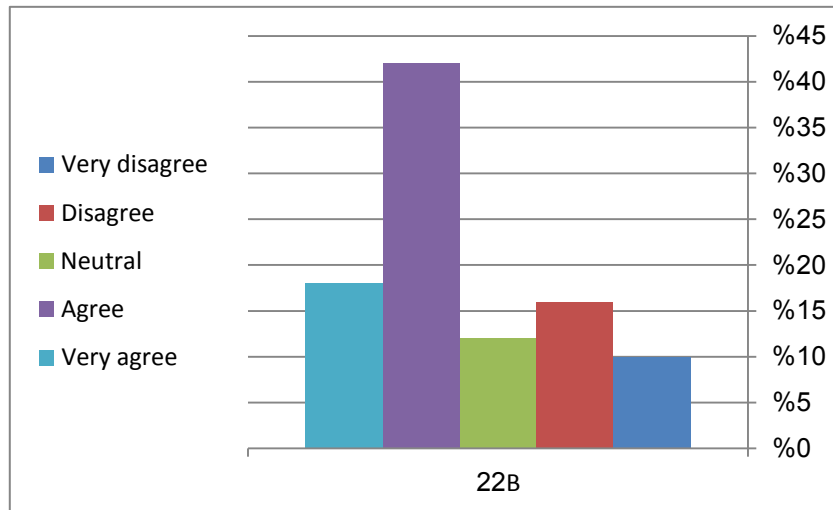

Figure (5-48) all cranes operators been specifically instructed in the identification of weight and center of gravity

23- With respect to the question of **(B23)** the respondents were asking **(Are all Crane operator usually is aware of crane design loads)**, from their answers the analysis shows the main of **3.16**, which is little greater than the mean average (**3**), which indicates that the most cranes operators didn't know the cranes design load.

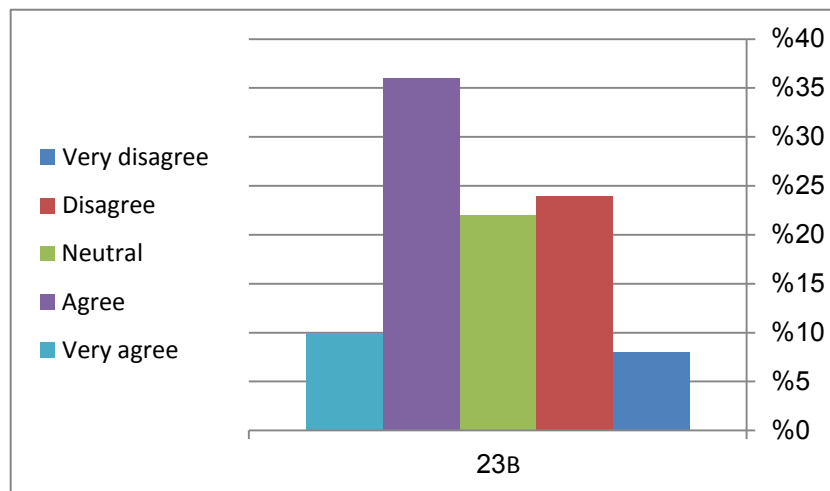

Figure (5-49) all Crane operator usually is aware of crane design loads

24- With respect to the question of **(B24)** the respondents were asking **(Have all slingers or banksmen been specifically instructed in the identification of weight and center of gravity before lifting a load?)**, from their answers the analysis shows the main of **2.56**, which is less than the mean average **(3)**, which indicates that the most cranes slingers didn't know weight and center of gravity before lifting a load which may cause many accident and fatal risk like loads fall on people and then kill them or causes fatal injuries.

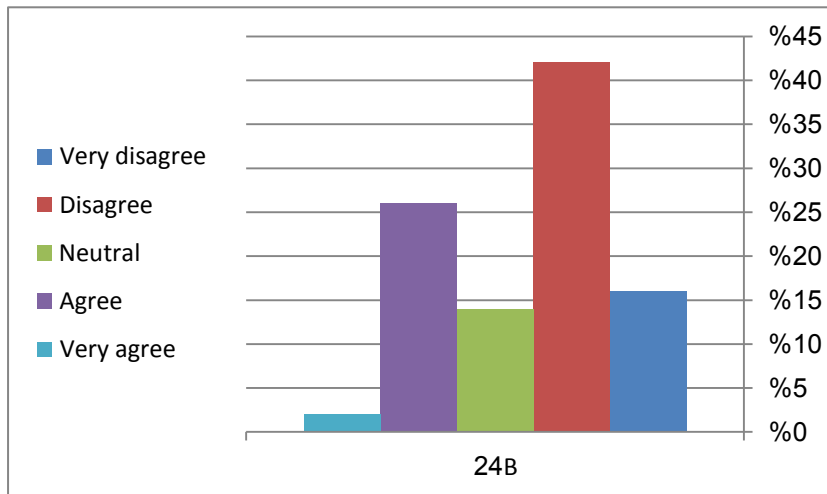

Figure (5-50) all banksmen been specifically instructed in the identification of weight and center of gravity

### 5.3.2.6 Summary of (Cranes and lifting appliances)

With respect to the scale **B (Cranes and lifting appliances)** the analysis shows the items **B22** has the largest average **3.43** and the item **B24** has the lowest average **2.56**. The general mean of this section is **3.05** which is closed to the mean average **3** which indicates that the respondents doesn't mostly aware about cranes drivers if he know the specific load and the Speed limits and most of cranes drivers work without slingers

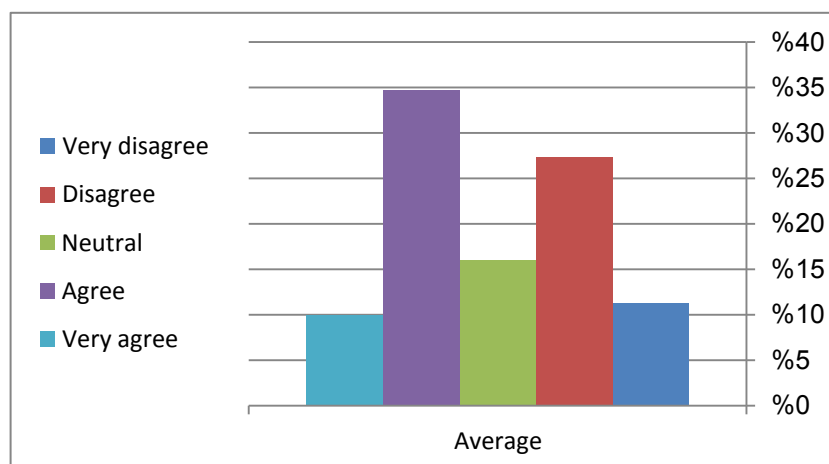

Figure (5-51) average (Cranes and lifting appliances)

25- With respect to the question of (B25) the respondents were asking (Is all plant and equipment being used appropriately the right equipment for the job?), from their answers the analysis shows the main of 3.50, which is greater than the mean average (3), which indicates that the most respondents make sure that their workers use the right equipment for every job.

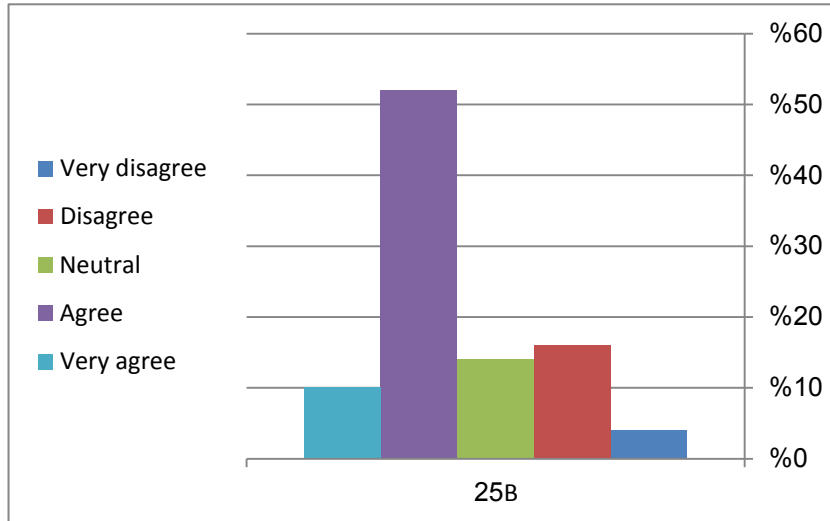

Figure (5-52) plants and equipment being used appropriately

26- With respect to the question of (B26) the respondents were asking (Is all plants and equipment in good repair?), from their answers the analysis shows the main of 3.78, which is greater than the mean average (3), which indicates that the most respondents make sure that their all plants and equipment In good condition.

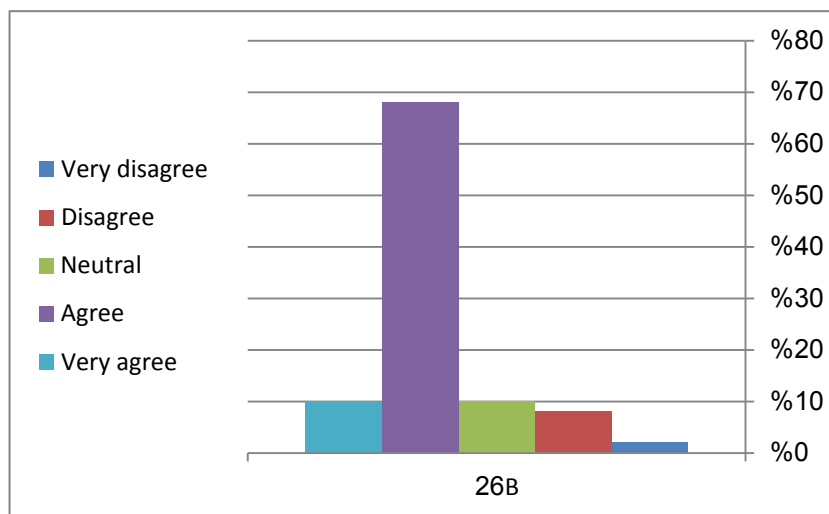

Figure (5-53)all plants and equipment in good repair

27- With respect to the question of (B27) the respondents were asking (Is a maintenance log maintained to record any defect and the date of their repair as well as preventive maintenance?), from their answers the analysis shows the main of 2.61, which is less than the mean average (3), which indicates that the most respondents doesn't have a maintenance logs to record any defect and the date of their repair.

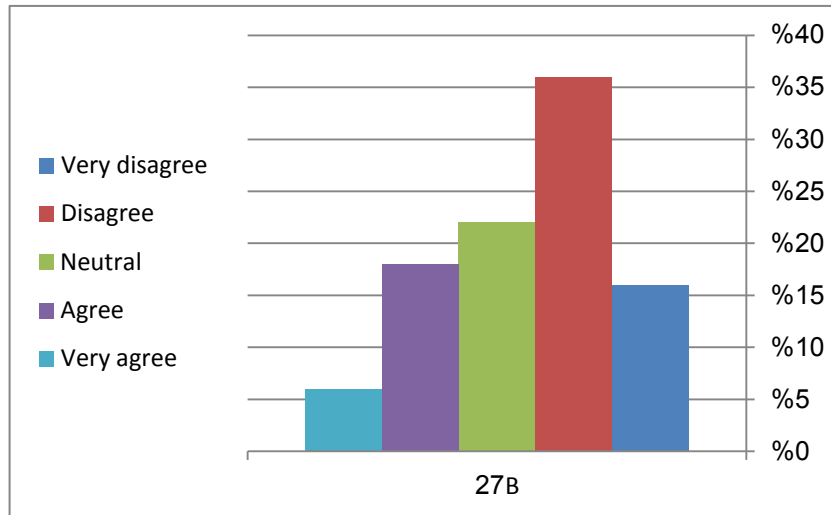

Figure (5-54)a maintenance log maintained to record any defect

### 5.3.2.7 Summary of (Plant and equipment)

With respect to the scale B (Plant and equipment) the analysis shows the items B26 has the largest average 3.78 and the item B27 has the lowest average 2.61. The general mean of this section is 3.30 which is greater than the mean average 3 which indicates that the respondents direct to get little improvement in using plant and equipment effectively.

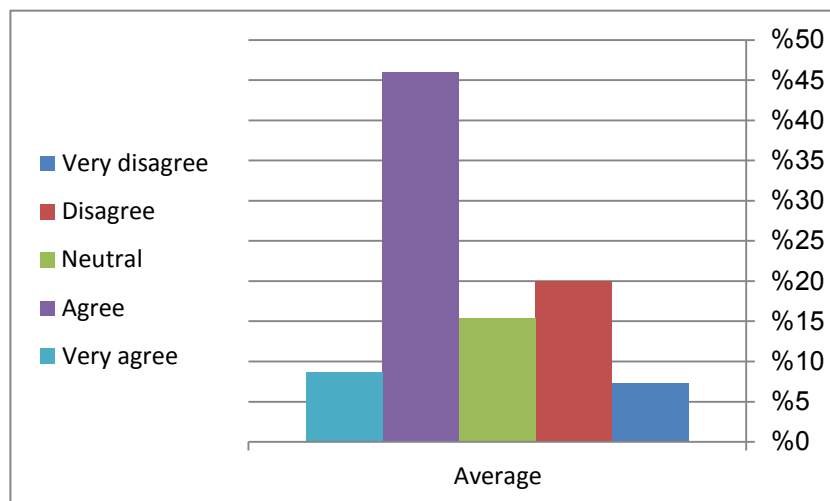

Figure (5-55)average (Plant and equipment)

28- With respect to the question of **(B28)** the respondents were asking **(we put site traffic plan to identify separate workflow pedestrian and vehicle routes with details given to driver where necessary)**, from their answers the analysis shows the main of **2.48**, which is less than the mean average **(3)**, which indicates that the most respondents doesn't put a traffic plan for their site which may expose worker to high risk because of the overlapping between the movement of people with vehicle.

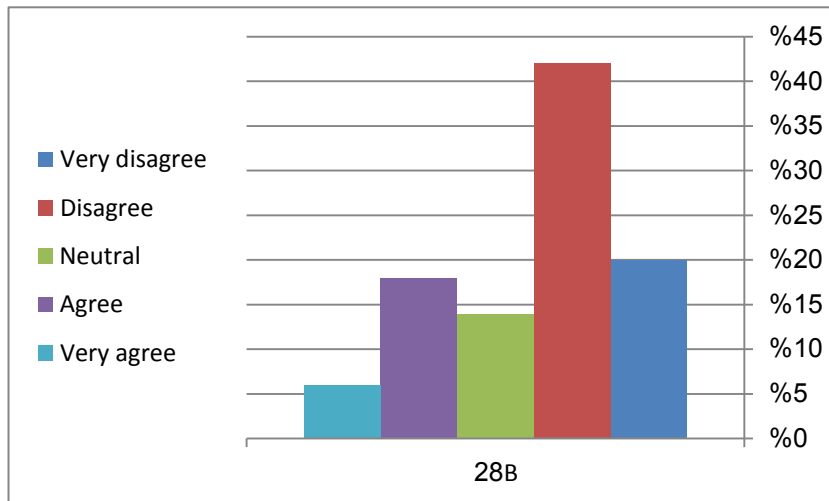

Figure (5-56) putting a site traffic plan

29- With respect to the question of **(B29)** the respondents were asking **(we usually make sure that the vehicles properly loaded, with protection against falling loads)**, from their answers the analysis shows the main of **3.29**, which is little greater than the mean average **(3)**, which indicates that the respondents didn't mostly make sure about the load of their vehicle which may cause many accidents like falling materials on people.

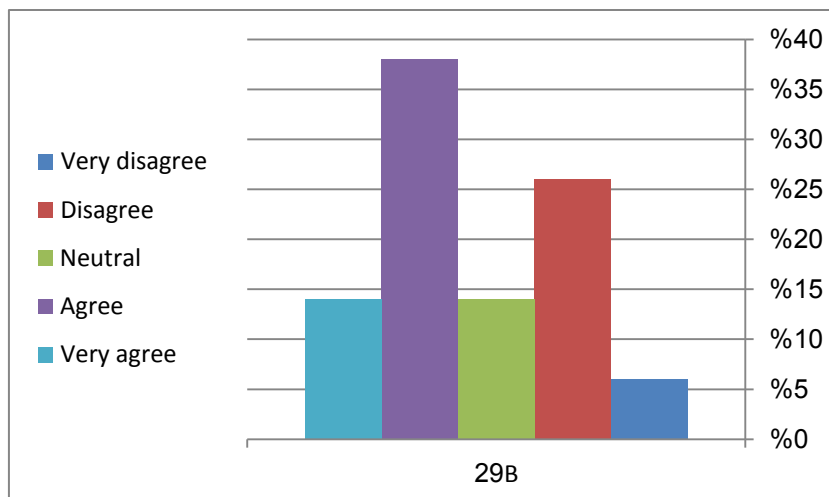

Figure (5-57) Ensure that the vehicles properly loaded

30- With respect to the question of **(B30)** the respondents were asking **(we enforce a specific speed limits for the vehicle drivers within the site)**, from their answers the analysis shows the main of **3.30**, which is greater than the mean average **(3)**, which indicates that the most of respondents enforce a specific speed limits for the vehicle drivers within the site which may Reduce the chances of collision accidents.

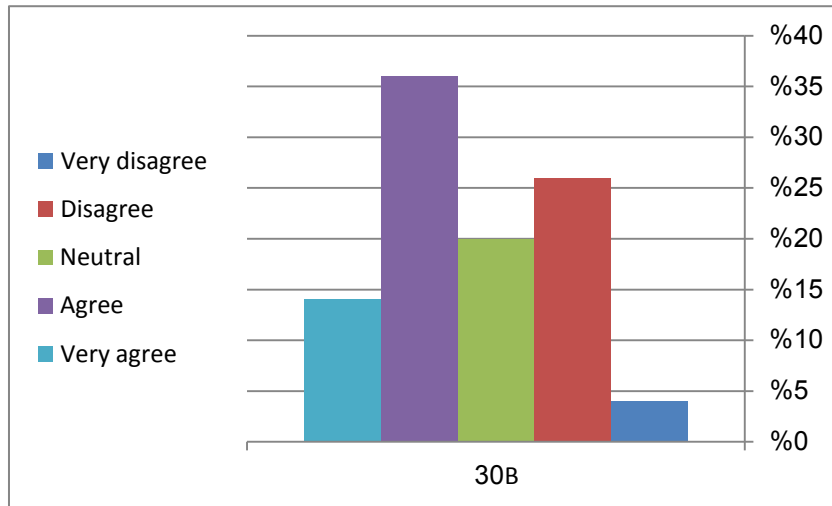

Figure (5-58)specifying speed limits for the vehicle drivers within the site

### 5.3.2.7 Summary of (Site traffic and vehicles)

With respect to the scale **B (Site traffic and vehicles)** the analysis shows the items **B30** has the largest average **3.30**and the item **B28**has the lowest average **2.48**. The general mean of this section is **3.02** which is closed to the mean average **3** which indicates that the respondents doesn't care about the vehicle that inter the site and exit from.

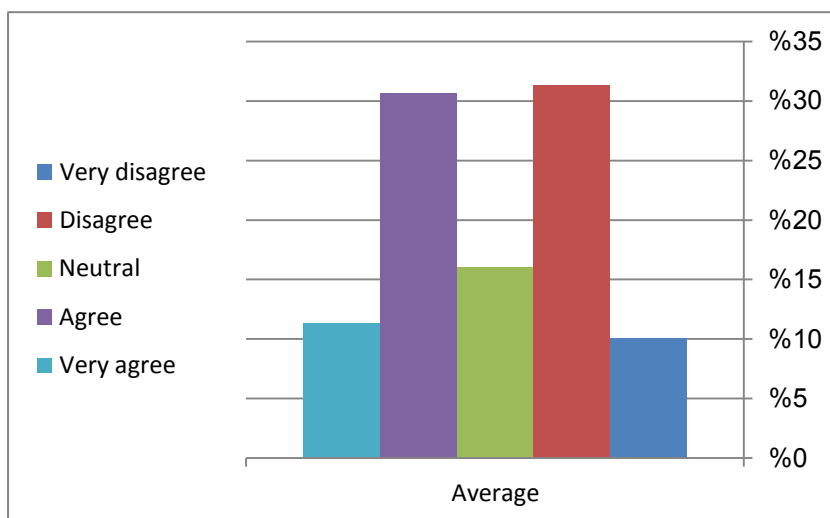

Figure (5-59)average of B (Site traffic and vehicles)

31- With respect to the question of **(B31)** the respondents were asking **(Has safe access by ladders been provided to all excavations?)**, from their answers the analysis shows the main of **3.58**, which is greater than the mean average **(3)**, which indicates that the most of respondents provide safe access by ladders to all excavations which may help the worker to get out of the holes.

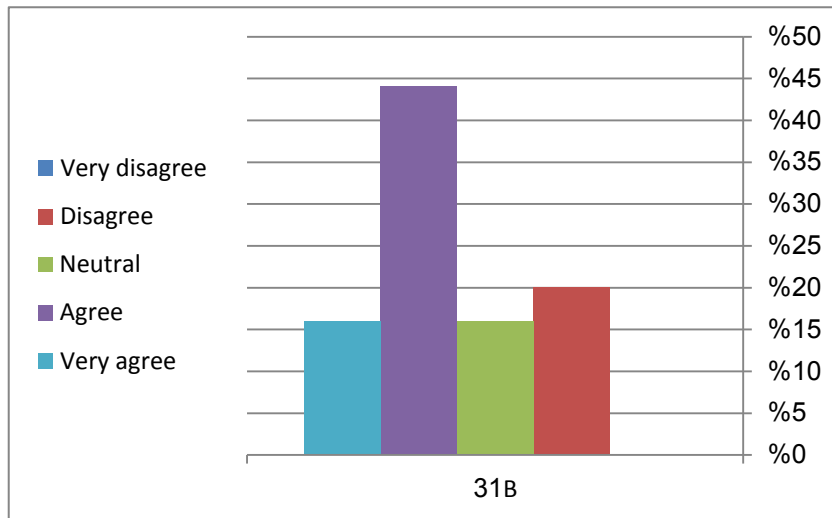

Figure (5-60) safe access by ladders are provided to all excavations

32- With respect to the question of **(B32)** the respondents were asking **(Are all excavations protected where necessary to prevent people, materials or vehicles falling in or causing them to collapse?)**, from their answers the analysis shows the main of **3.52**, which is greater than the mean average **(3)**, which indicates that the most of respondents provide safe access by ladders to all excavations which may help the worker to get out of the holes.

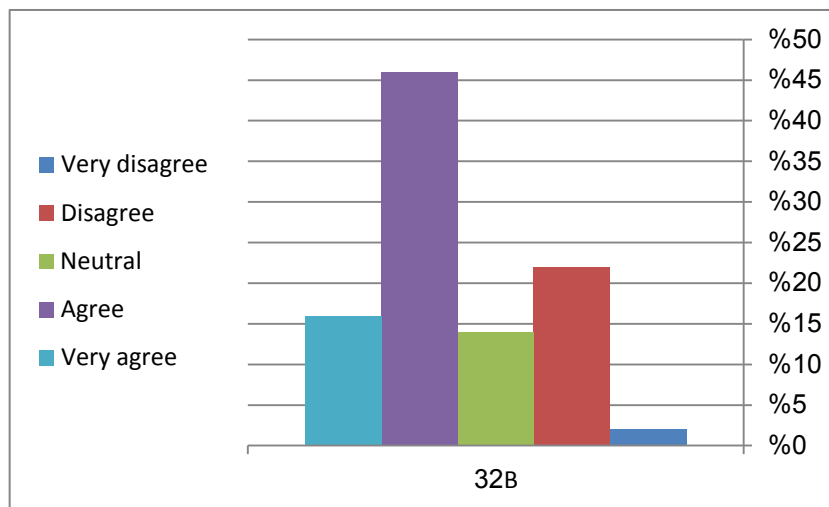

Figure (5-61) excavations protected to prevent people, materials or vehicles falling

33- With respect to the question of **(B33)** the respondents were asking **(we protect nearby structures from being affected by an excavation)**, from their answers the analysis shows the main of **3.52**, which is greater than the mean average **(3)**, which indicates that the most of respondents they make sure that nearby structures are protected from the excavations in their site.

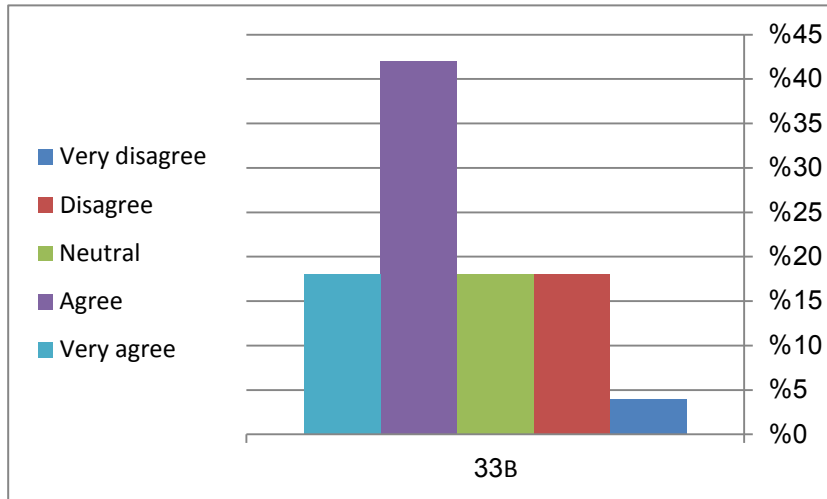

Figure (5-62)protect nearby structures from being affected by an excavation

34- With respect to the question of **(B34)** the respondents were asking **(we inspect all excavations by a competent person before each shift and after any event likely to compromise stability, with the result recorded)**, from their answers the analysis shows the main of **3.04**, which is closed to the mean average **(3)**, which indicates that the most of respondents they didn't care about inspecting the excavations before each shift and after any event which may cause many accidents like collapsing of the holes on the workers and that's lead them to death.

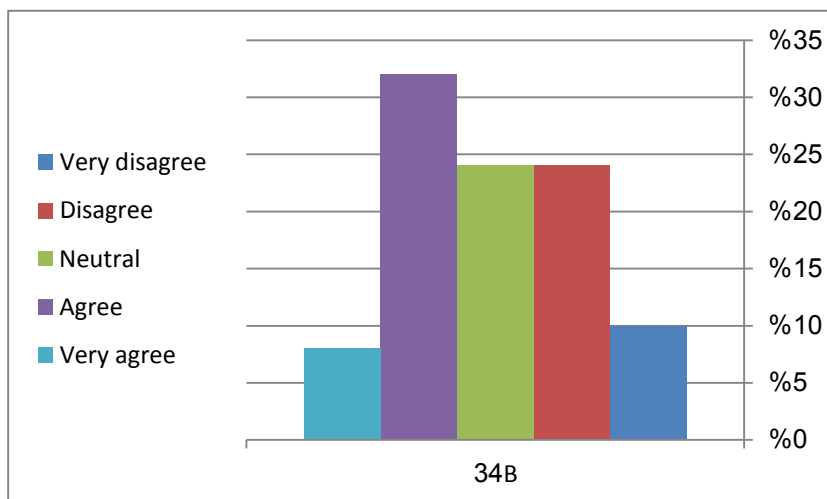

Figure (5-63)inspecting all excavations by a competent person before eachshift

35- With respect to the question of (B35) the respondents were asking (Is there 1m of clear space at the edges of all excavations, between the edges and spoil heaps or materials stacks? ), from their answers the analysis shows the main of 3.54, which is greater than the mean average (3), which indicates that the most of respondents they care about making 1m of clear space at the edges of all excavations, between the edges and spoil heaps or materials stacks To allow workers to take a sufficient distance to practice their work comfortably .

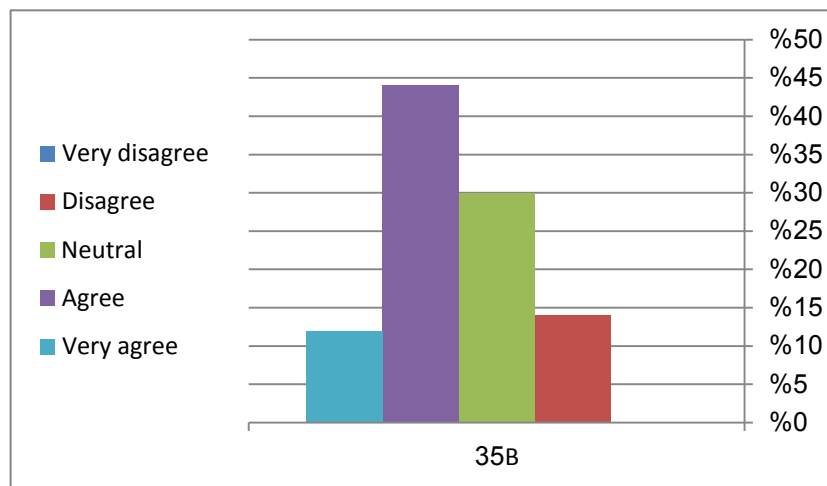

Figure (5-64) Leaving 1m of clear space at the edges of all excavations

### 5.3.2.8 Summary of (Excavations)

With respect to the scale B(Excavations)the analysis shows the items B31 has the largest average 3.58and the item B34 has the lowest average 3.04. The general mean of this section is 3.44 which is greater than the mean average 3which indicates that the respondents have little care about workers who works in excavations.

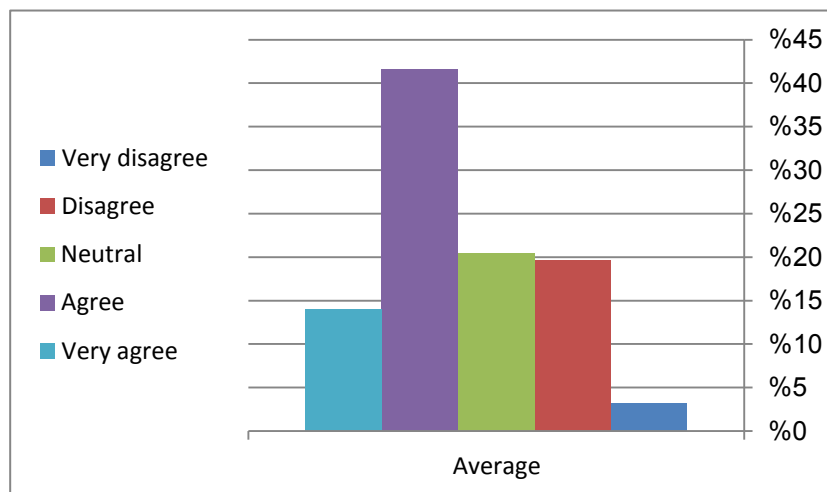

Figure (5-65)average of (excavations)

36- With respect to the question of **(B36)** the respondents were asking **(we put a site emergency plan, detailing steps required to evacuate the site in case of fire, and for confined space rescue)**, from their answers the analysis shows the main of **2.70**, which is less than the mean average **(3)**, which indicates that the most of respondents they care didn't care about putting fire emergency plan which may cause many casualties and losses when a fire occurs.

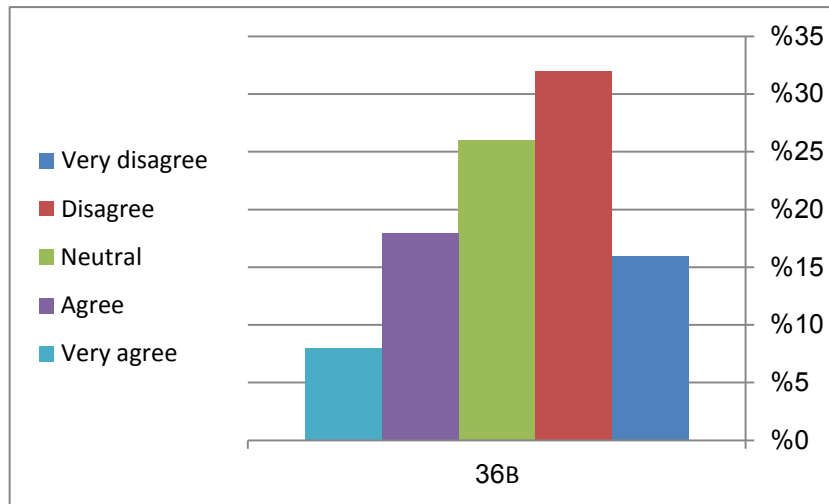

Figure (5-66) putting a site emergency plan

37- With respect to the question of **(B37)** the respondents were asking **(Is there an appropriate means of raising the alarm, which is known to be clearly audible at all points on the site?)**, from their answers the analysis shows the main of **2.62**, which is less than the mean average **(3)**, which indicates that the most of respondents they care didn't care about fire alarm which may cause many casualties and losses when a fire occurs because most of the worker will not notice if there are a fire in Somewhere in the site.

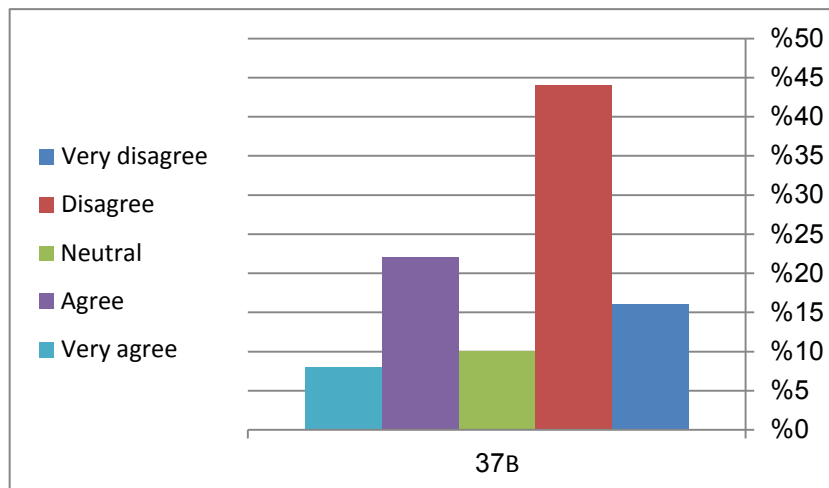

Figure (5-67) appropriate means of raising the alarm in case of fire

38- With respect to the question of **(B38)** the respondents were asking **(Are appropriate numbers of fire extinguishers present and marked?)**, from their answers the analysis shows the main of **3.04**, which is closed to the mean average **(3)**, which indicates that the most of respondents they didn't care about fire extinguishers which may cause fires from small spark.

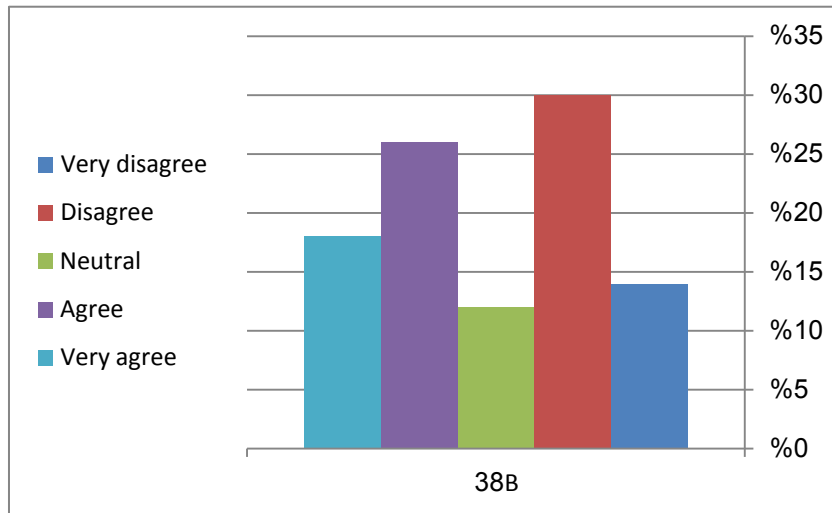

Figure (5-68) appropriate numbers of fire extinguishers present and marked

39- With respect to the question of **(B39)** the respondents were asking **(we made arrangements to remove waste regularly, and for storing it in bins prior to removal)**, from their answers the analysis shows the main of **3.08**, which is closed to the mean average **(3)**, which indicates that the most of respondents they care didn't care about keeping the site clean and tidy by making arrangement to remove waste regularly, and for storing it in bins prior to removal and that may lead to obstruct the movement of workers in the event of fires, leading to increased risk and losses of life .

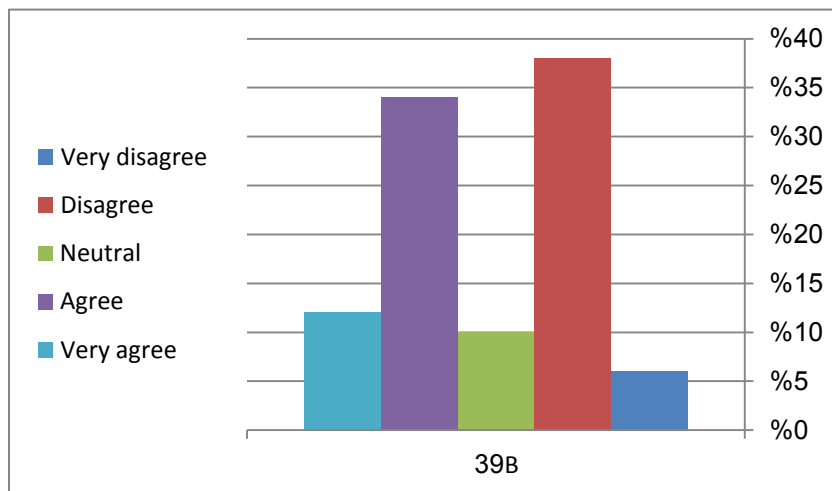

Figure (5-69) arrangements to remove waste regularly

40- With respect to the question of (B40) the respondents were asking (Is there an effective smoking ban where flammable materials are used, stored or installed?), from their answers the analysis shows the main of 3.40, which is greater than the mean average (3), which indicates that the most of respondents forbid smoking on their workers where flammable materials are used, stored or installed.

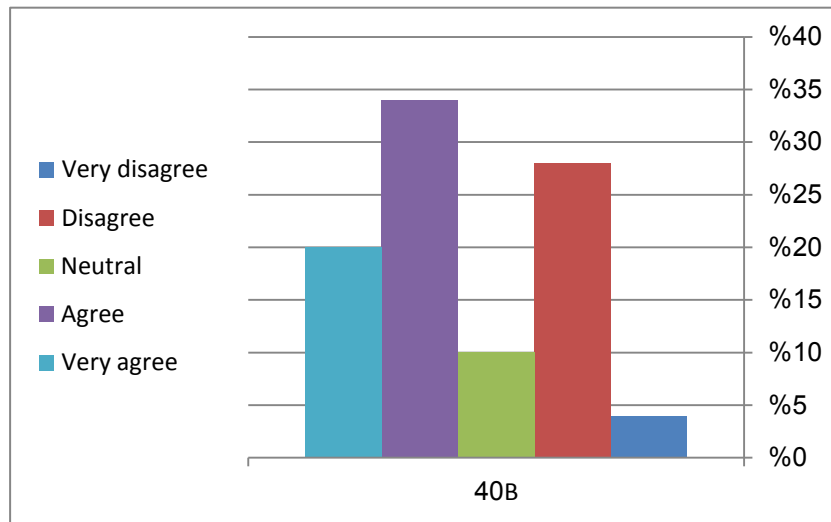

Figure (5-70)effective smoking ban where flammable materials are stored

### 5.3.2.9 Summary of (Fire and other emergencies)

With respect to the scale B (Fire and other emergencies) the analysis shows the items B40 has the largest average 3.40 and the item B37 has the lowest average 2.62. The general mean of this section is 2.97 which is greater than the mean average 3 which indicates that the respondents doesn't aware about Fire emergency at all while that more accidents caused by fire.

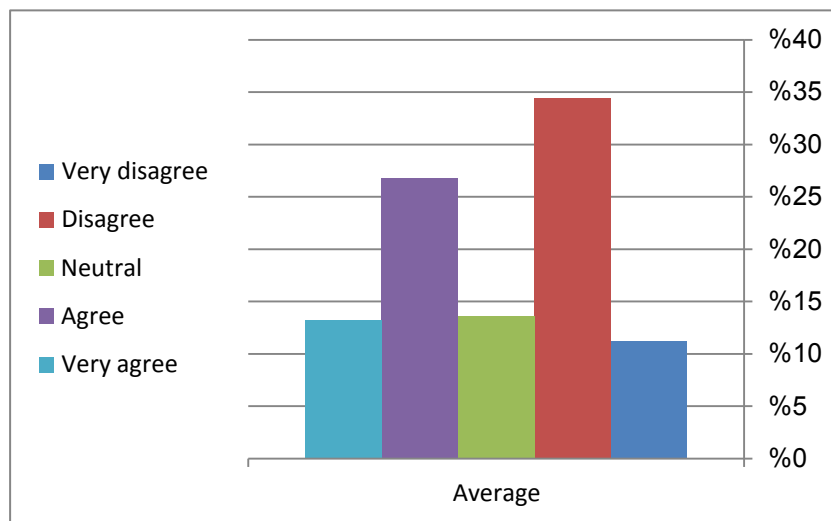

Figure (5-71)average of (Fire and other emergencies)

41- With respect to the question of **(B41)** the respondents were asking **(Are appropriate precautions in place to guard against striking underground services during the work?)**, from their answers the analysis shows the main of **3.29**, which is little greater than the mean average **(3)**, which indicates that the most of respondents didn't mostly put precaution to warn worker from striking underground services during the work to avoid accident.

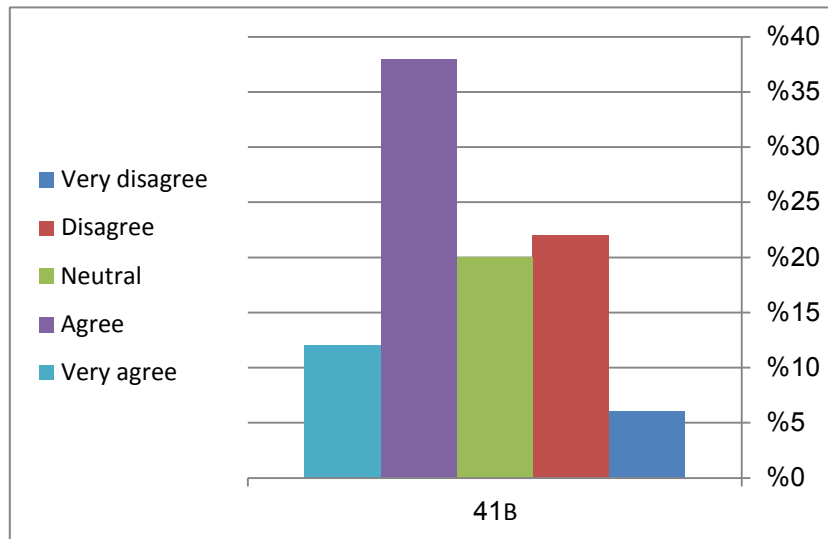

Figure (5-72) appropriate precautions in place to guard against striking underground services

42- With respect to the question of **(B42)** the respondents were asking **(Have all temporary circuits been fitted with residual current devices?)**, from their answers the analysis shows the main of **3.48**, which is greater than the mean average **(3)**, which indicates that the respondents make checks if the temporary circuits fit with residual current devices.

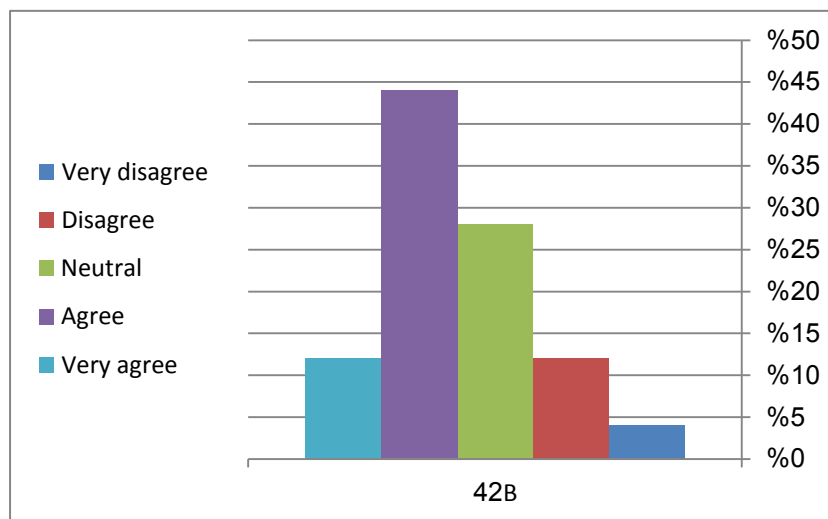

Figure (5-73)all temporary circuits fitted with residual current devices

43- With respect to the question of **(B43)** the respondents were asking **(Are all cables and leads protected from damages?)**, from their answers the analysis shows the main of **3.88**, which is greater than the mean average (**3**), which indicates that the respondents make checks if all cables and leads protected from damages to protect worker from Electric shocks which leads to die.

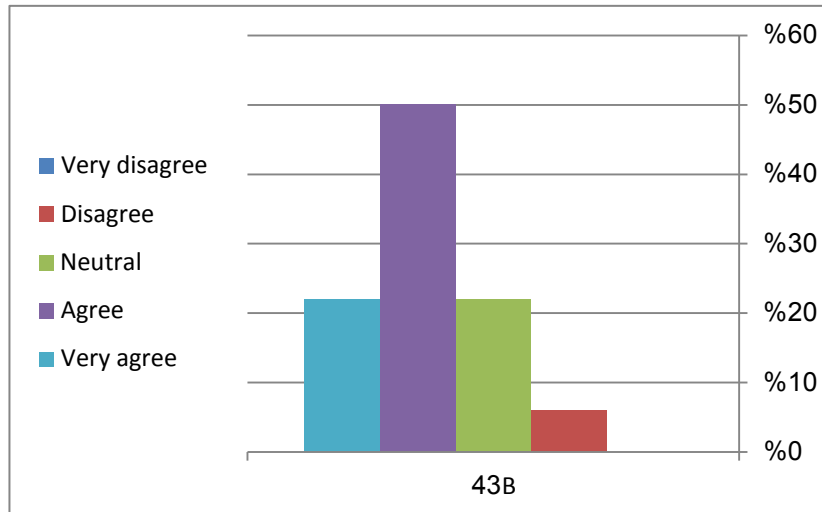

Figure (5-74)all cables and leads protected from damages

44- With respect to the question of **(B44)** the respondents were asking **(we have an appropriate system in place to ensure that the temporary electrical supply system is checked by a competent person at appropriate intervals)**, from their answers the analysis shows the main of **3.12**, which is near to the mean average (**3**), which indicates that the respondents didn't care about checking electrical supply system which may cause electric accidents and problems and that causes delays in work.

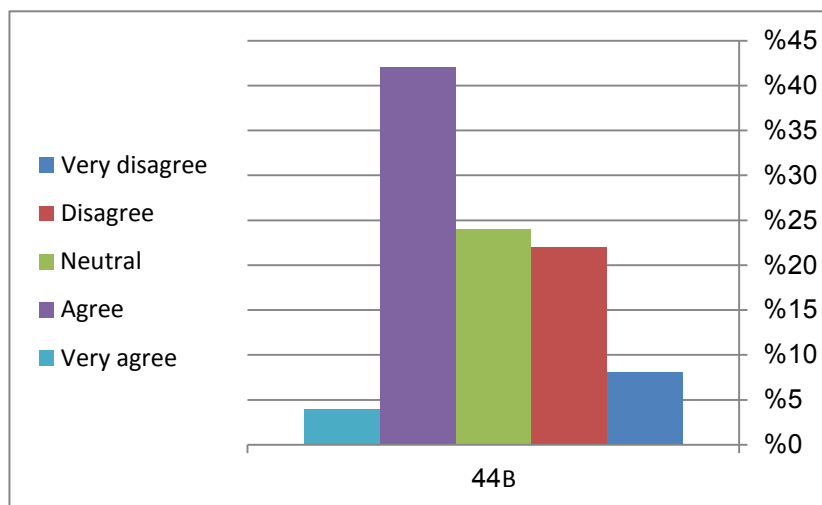

Figure (5-75)the temporary electrical supply system is checked by a competent person

45- With respect to the question of (**B45**) the respondents were asking (**Are all electrical tools and equipment subject to document examination and testing regime?**), from their answers the analysis shows the main of **2.96**, which is little than the mean average (**3**), which indicates that the respondents doesn't aware about electrical tools and equipment and doesn't makes checks and tests for it to insure that are in a good condition.

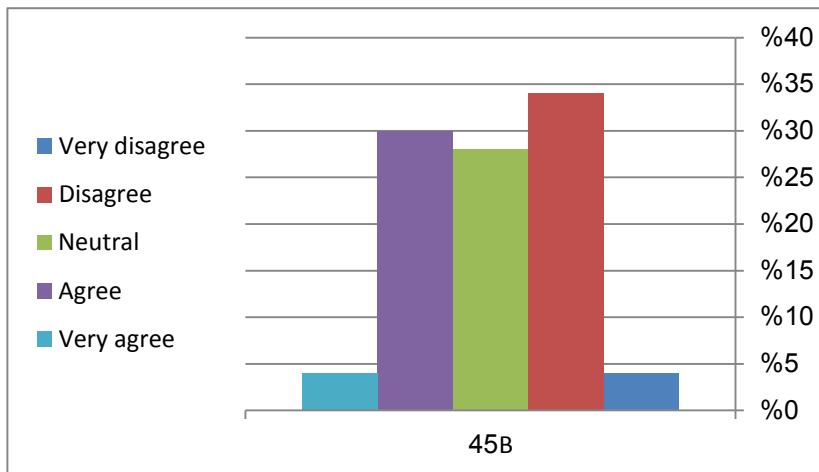

Figure (5-76)all electrical tools and equipment subject to document examination and testing regime

### 5.3.2.10 Summary of (Electricity)

With respect to the scale **B (Electricity)** the analysis shows the items **B43** has the largest average **3.88**and the item **B45** has the lowest average **2.96**. The general mean of this section is **3.35** which is greater than the mean average **3** which indicates that the respondents have a little aware about electricity and it's danger and they try to make precautions to protect their workers from it.

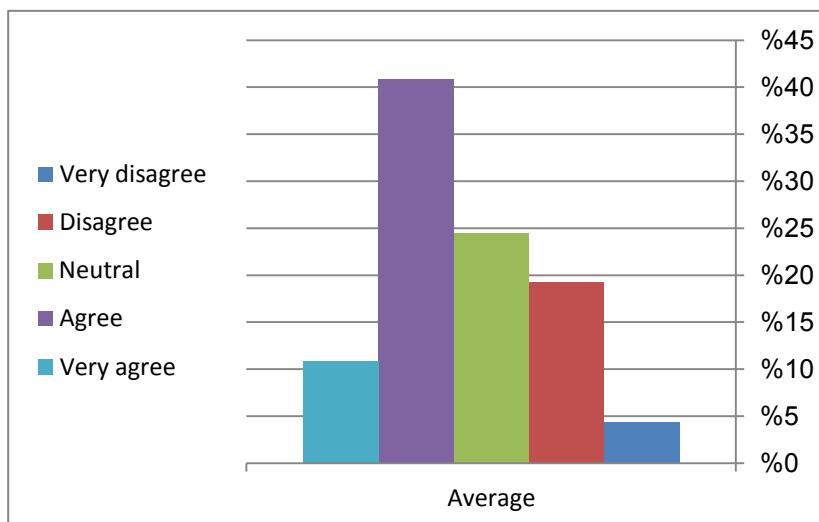

Figure (5-77)average of (Electricity)

46- With respect to the question of **(B46)** the respondents were asking **(we identify all hazardous substances and we assess their Potential risks)**, from their answers the analysis shows the main of **3.25**, which is little greater than the mean average **(3)**, which indicates that the respondents didn't mostly care about hazardous substances which may Expose workers to high risk due to lack of knowledge of its risks.

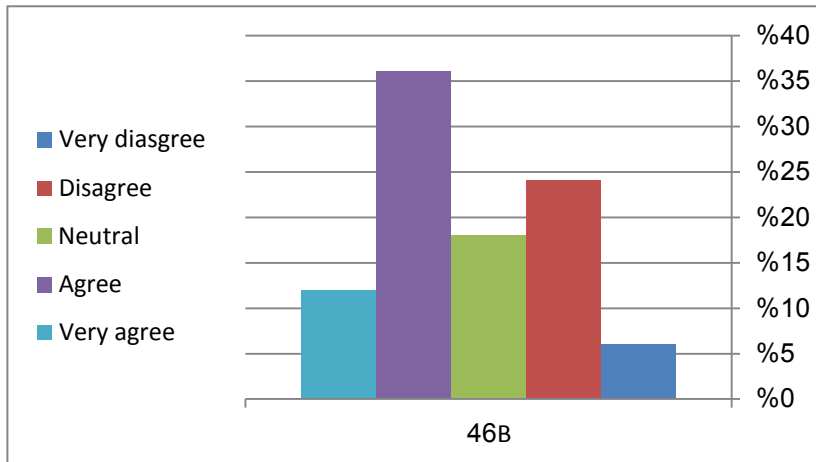

Figure (5-78)identifying all hazardous substances and we assess their Potential risks

47- With respect to the question of **(B47)** the respondents were asking **(we have appropriate precautions in a Storage areas of hazardous materials include signs, limitations on access and use of protective clothing and equipment)**, from their answers the analysis shows the main of **3.02**, which is closed to the mean average **(3)**, which indicates that the respondents didn't care about signs, limitations on access and using of protective clothing and equipment in the storage areas of hazardous materials which may Leads to many risks such as fire.

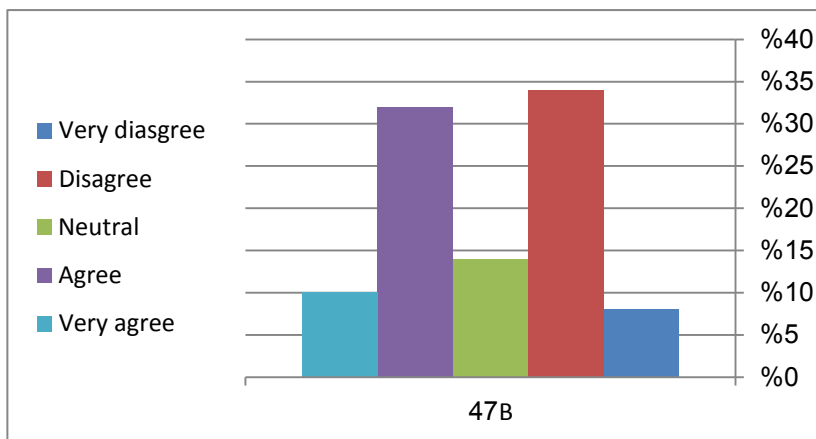

Figure (5-79)appropriate precautions in Storage areas of hazardous materials include signs, limitations on access

### 5.3.2.11 Summary of (Hazardous substances)

With respect to the scale **B (Hazardous substances)** the analysis shows the general mean of this section is **3.12** which is near to the mean average **3** which indicates that the respondents doesn't mostly care about making a warning in hazardous substances storage.

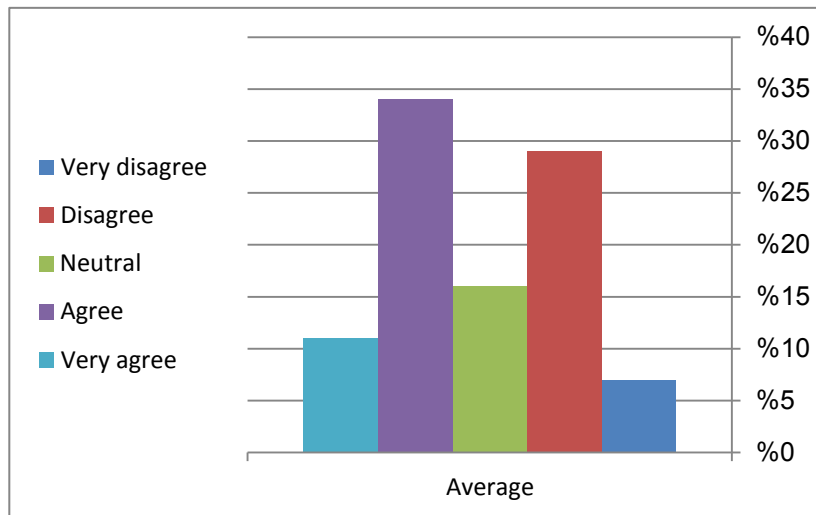

Figure (5-80)average of (Hazardous substances)

48- With respect to the question of **(B48)** the respondents were asking **(The company is providing all possible social care facilities for all workers)**, from their answers the analysis shows the main of **2.96**, which is less than the mean average **(3)**, which indicates that the respondents didn't care about their workers and they didn't offer them all possible social care facilities because most of the company didn't employ a constant workers.

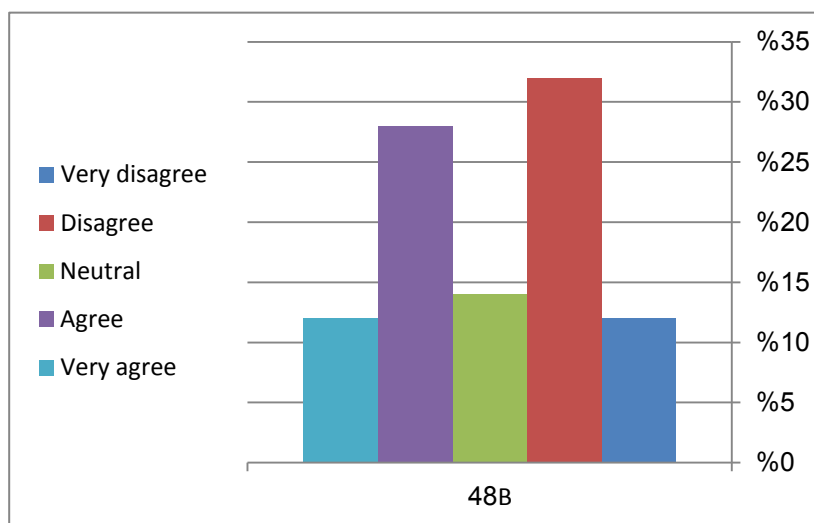

Figure (5-81)The Company is providing all possible social care facilities for all workers

49- With respect to the question of **(B49)** the respondents were asking **(The company offers for its workers special areas on the site to allow them to rest and to prepare their food at the break.)**, from their answers the analysis shows the main of **3.06**, which is closed to the mean average **(3)**, which indicates that the respondents didn't care about their workers and they didn't offer them all possible social care facilities because most of the company didn't employ a constant workers so each worker procure his food and drink by himself.

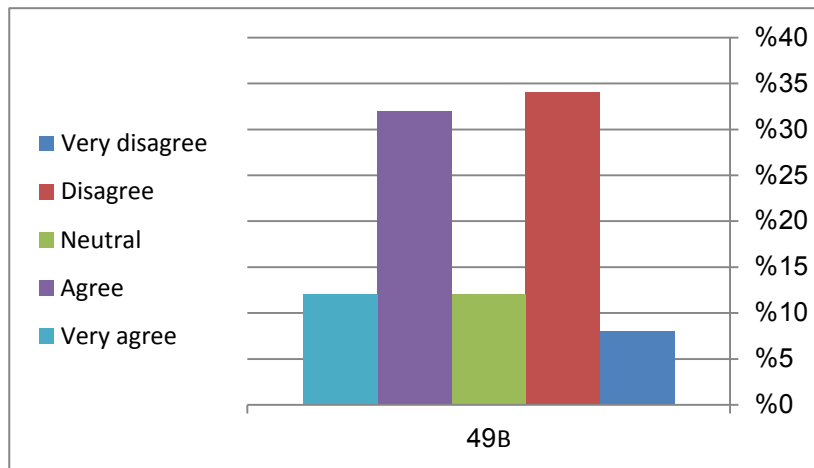

Figure (5-82) offering special areas to allow workers to rest

50- With respect to the question of **(B50)** the respondents were asking **(We provide small toilets for workers in workplaces.)**, from their answers the analysis shows the main of **2.96**, which is less than the mean average **(3)**, which indicates that the respondents didn't care about their workers and they didn't offer them small toilets for workers in workplaces which may lead the workers to delays the work because they search for toilets and also they will eat food by their dirty hands and that's cause diseases.

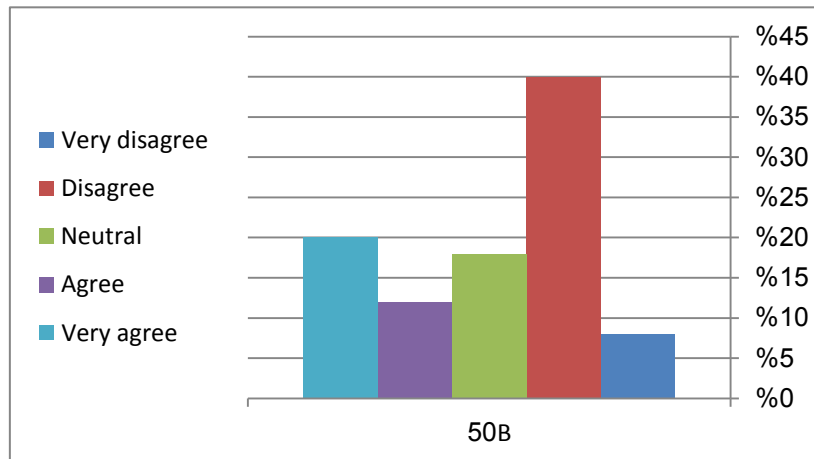

Figure (5-83) providing small toilets for workers in workplaces

51- With respect to the question of **(B51)** the respondents were asking **(We provide an adequate supply of drinking water for the workers at the work site.)**, from their answers the analysis shows the main of **3.52**, which is greater than the mean average (**3**), which indicates that the most respondents provide adequate supply of drinking water for the workers at the work site because water is the basic needs of life.

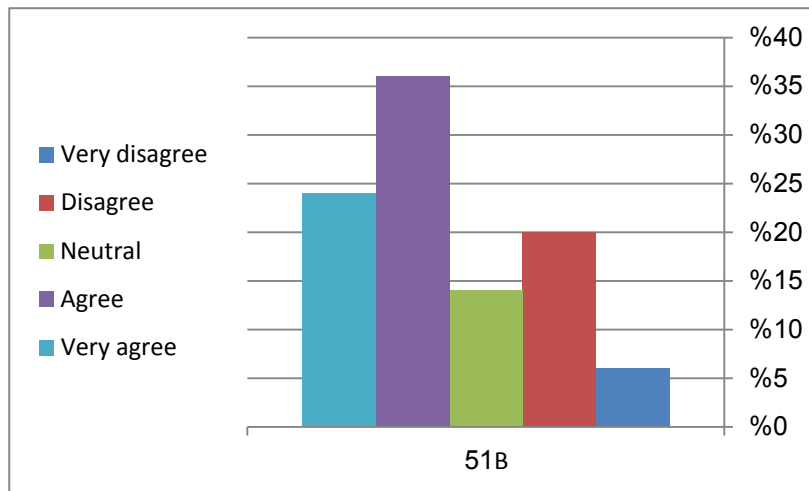

Figure (5-84) provide an adequate supply of drinking water for the workers

52- With respect to the question of **(B52)** the respondents were asking **(The company make an adequate assessment for the first aid requirements and provide appropriate facilities.)**, from their answers the analysis shows the main of **3.04**, which is closed to the mean average (**3**), which indicates that the most respondents didn't care about first aid requirement and facilities which will help workers When injury occurs.

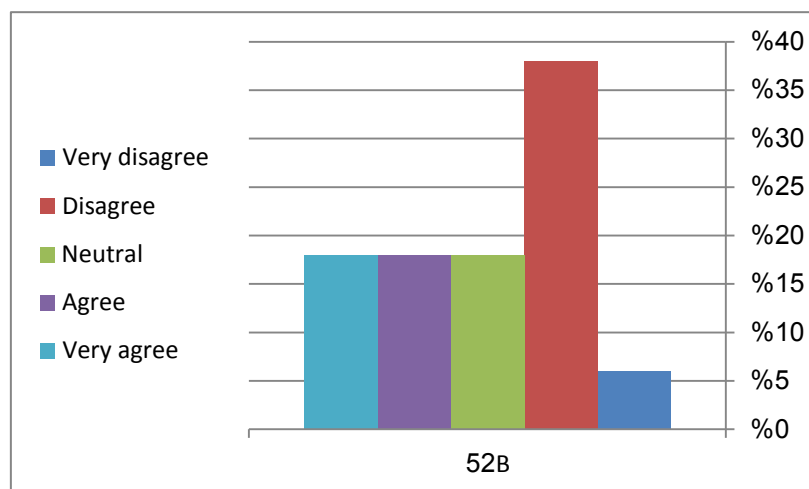

Figure (5-85) making an adequate assessment for the first aid requirements

### 5.3.2.12 Summary of (Welfare facilities)

With respect to the scale **B (Welfare facilities)** the analysis shows the items **B51** has the largest average **3.52** and the items **B50, 48** have the lowest average **2.96**. The general mean of this section is **3.04** which is closed to the mean average **3** which indicates that the respondents doesn't mostly care about their workers and they didn't offer them all possible social care facilities because most of the company didn't employ a constant workers.

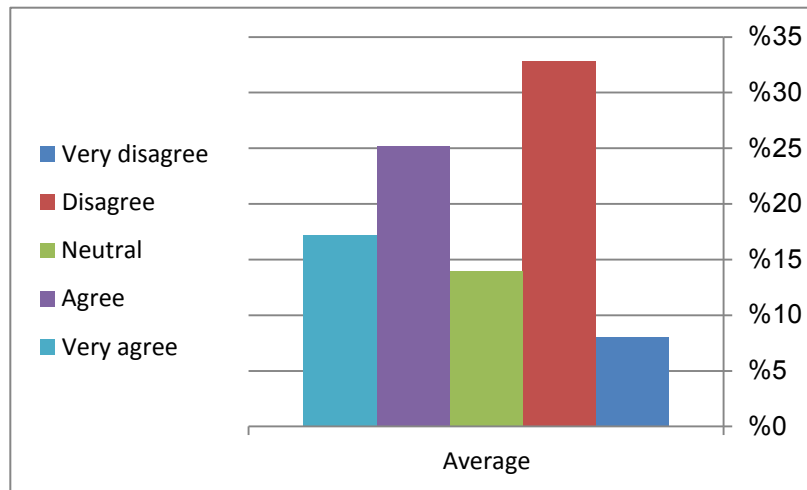

Figure (5-86) average of (welfare facilities)

53- With respect to the question of **(B53)** the respondents were asking **(We develop a plan of work to reduce the noise inside and outside locations.)**, from their answers the analysis shows the main of **2.35**, which is less than the mean average **(3)**, which indicates that the most respondents didn't care about Noise pollution which may cause neighbor nuisance and ears problems.

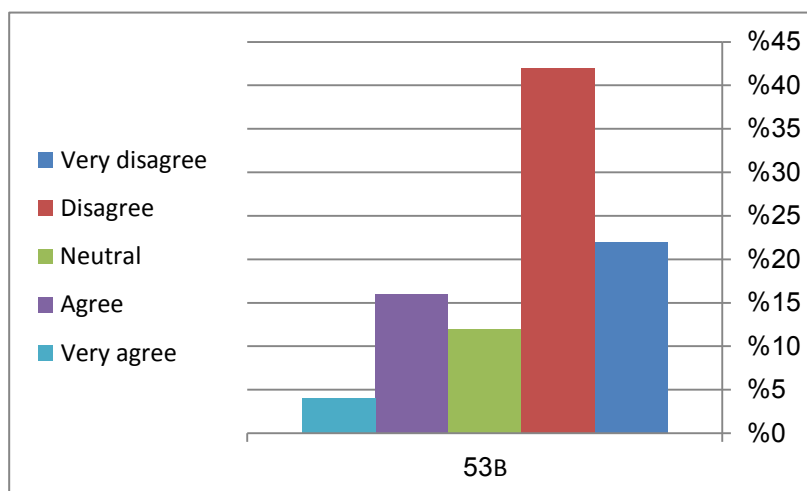

Figure (5-87)develop a plan of work to reduce the noise inside and outside locations

54- With respect to the question of **(B54)** the respondents were asking **(We provide ear protection headphones for each worker in the areas of noise)**, from their answers the analysis shows the main of **2.56**, which is less than the mean average **(3)**, which indicates that the most respondents didn't care about providing ear protection headphones for each worker which may expose them to many ear diseases like Deafness or hearing lose.

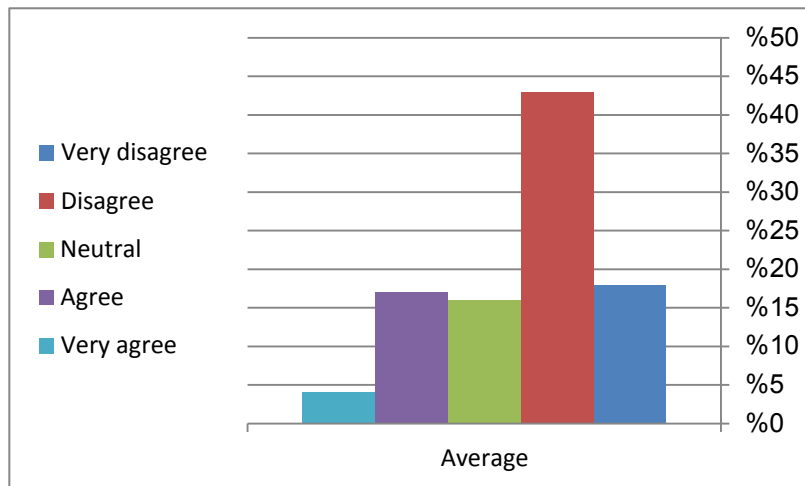

Figure (5-88)providing ear protection headphones for each worker in the areas of noise

### 5.3.2.13 Summary of (Noise)

With respect to the scale **B (Noise)** the analysis shows the general mean of this section is **2.45** which is less than the mean average **3** which indicates that the most respondents doesn't try to make a plan to reduce the noise outside and inside the work site and they doesn't commit their worker to wear a head phone.

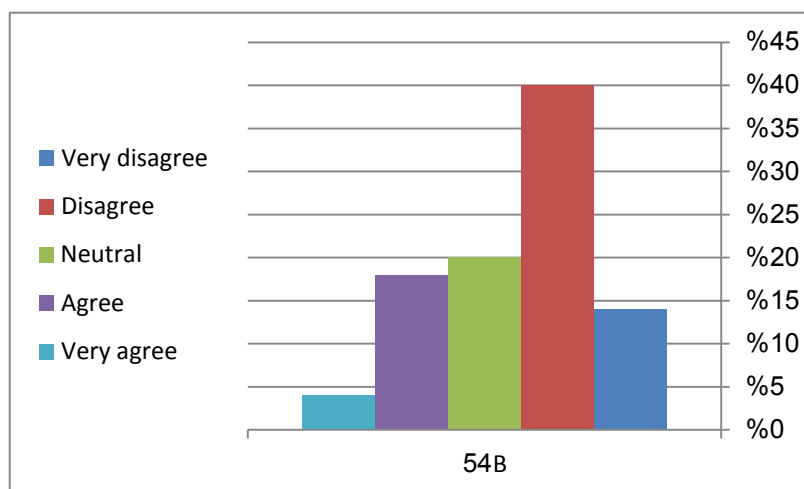

Figure (5-89) average of (Noise)

55- With respect to the question of **(B55)** the respondents were asking **(We define a appropriate personal protective equipment for all workers in each location depending on the nature of his work and provided them e.g. helmet, eye protection, hearing protection, respiratory protective equipment, gloves, safety footwear, protective outdoor clothing for adverse environments including dusty, wet, or dirty conditions.)**, from their answers the analysis shows the main of **2.61**, which is less than the mean average **(3)**, which indicates that the most respondents didn't care about providing their workers Personal protective equipment to protect them from the risks that may occur to them but, most of respondents said that most of workers didn't like to wear Personal protective equipment Because it bother them at work .

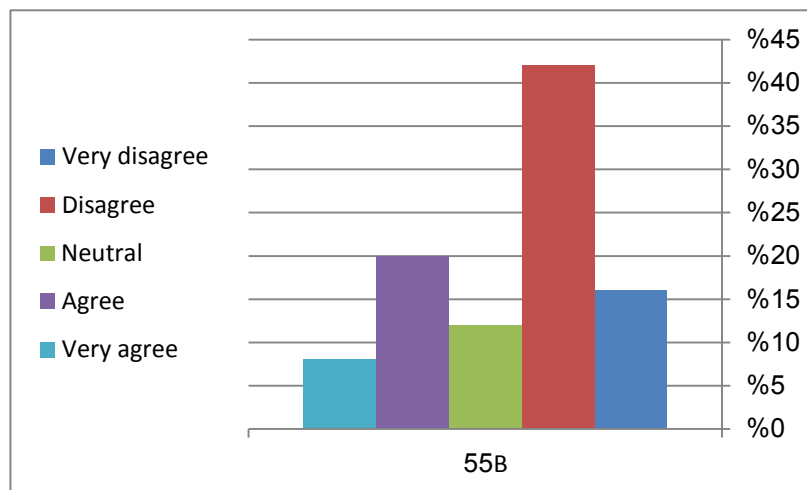

Figure (5-90) defining appropriate personal protective equipment depending on the nature of the work and provided them to workers

56- With respect to the question of **(B56)** the respondents were asking **(we make checks for all personal protective equipment if it is in good condition and properly maintained)**, from their answers the analysis shows the main of **2.57**, which is less than the mean average **(3)**, which indicates that the most respondents didn't care about maintaining the Personal protective equipment.

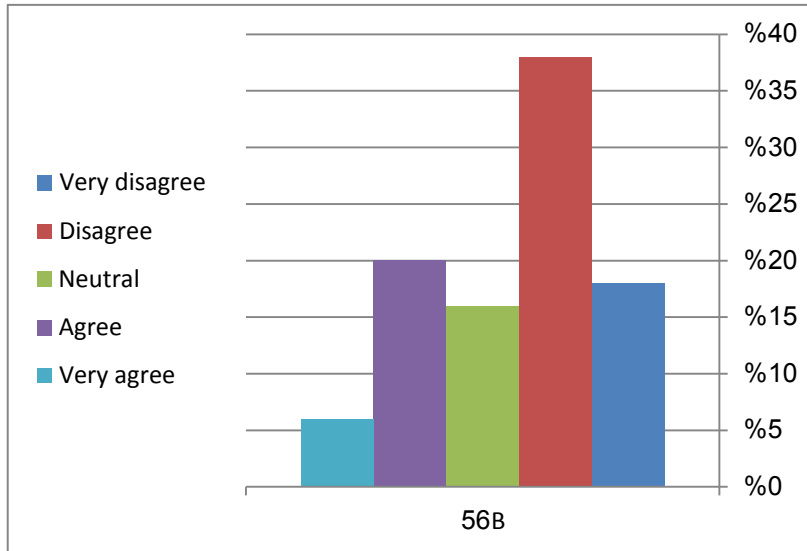

Figure (5-91) making checks for all personal protective equipment

56- With respect to the question of **(B57)** the respondents were asking **(we have arrangements for replacement of worn or lost equipment)**, from their answers the analysis shows the main of **2.98**, which is less than the mean average **(3)**, which indicates that the most respondents didn't care the Personal protective equipment at all .

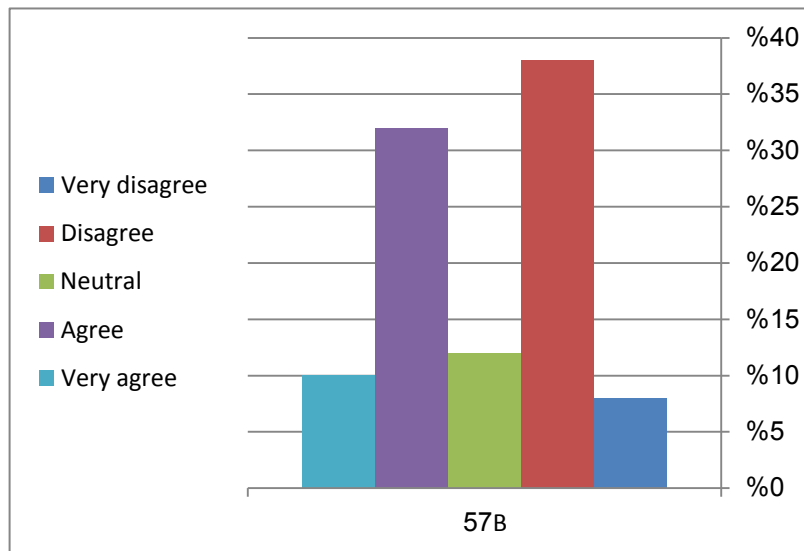

Figure (5-92) making arrangements for replacement of worn or lost equipment

### 5.3.2.14 Summary of (Personal protective equipment)

With respect to the scale **B (Personal protective equipment)** the analysis shows the items B57 has the largest average **2.98** and the item B56 has the lowest average **2.57**. The general mean of this section is **2.72** which is less than the mean average **3** which indicates that the respondents doesn't offer their workers protective equipment and they doesn't aware if their worker wear it if not.

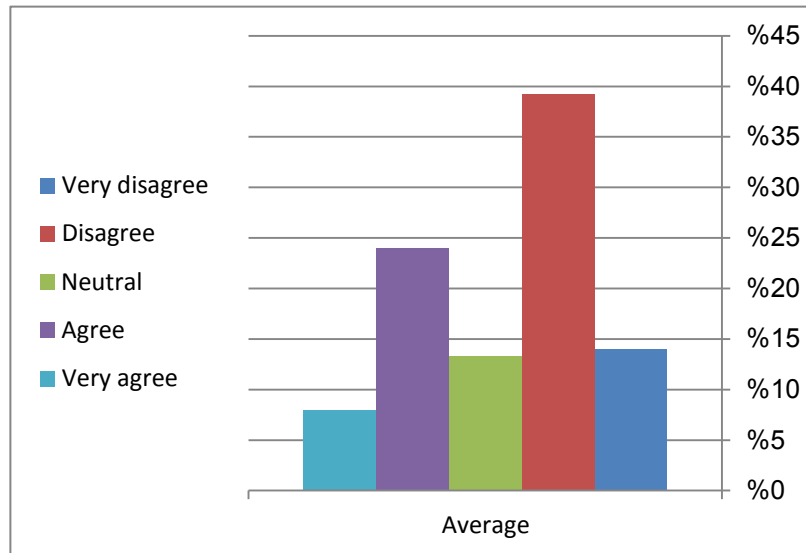

Figure (5-93) average for (personal protective equipment)

## 5.4 RANKING THE FACTORS

From the last analysis and discussion, the factors that affect on construction safety performance were listed according to the lower mean.

Table (5-3) Ranking the Factors:

No.	The factor	Mean	Std. Deviation	Rank
1	At an Organization Level (Administrative factors)	2.73	1.227	1
2	At Project level	3.21	1.328	2

Source: Field survey

That indicates that the factors at an organization level have a greater impact on the construction industry than the factors at the project level.

### 5.4.1 The Most 7 effective factors at Organization Level:

Table (5-4) Most 7 effective factors at Organization Level:

<b>Description</b>	<b>Mean</b>	<b>Std. Deviation</b>	<b>Rank</b>
Devoting adequate hours to train workers on safety means	2.32	1.039	1
Distributing safety booklets that has big effect in making workers aware of safety issues	2.40	1.178	2
Appointing a trained safety representative on the work site to ensure safety performance	2.42	1.162	3
The existence of special department to monitor the Occupational Safety and Health	2.49	1.157	4
Insuring workers by company compensation insurance	2.50	1.288	5
Allocating amount of money from company capital for occupational safety and health issues	2.51	1.244	6
punishments for a workers who breaks safety regulations and Incentives for workers who follow the safety instruction	2.62	1.123	7

Source: Field survey

### 5.4.2 Ranking the Factors at Project Level:

Table (5-5) Ranking the Factors at Project Level

<b>Description</b>	<b>Mean</b>	<b>Std. Deviation</b>	<b>Rank</b>
Personal protective equipment	2.45	1.114	1
Noise	2.72	1.205	2
Ladders and stepladders	2.82	1.129	3
Fires and other emergencies	2.97	1.244	4
Site traffic and vehicles	3.02	1.167	5
Power access equipment	3.05	1.200	6
Cranes and lifting appliances	3.05	1.7232	6
Welfare	3.11	1.260	7
Hazardous substances	3.12	1.178	8
Plant and equipment	3.30	1.001	9
Electricity	3.35	1.001	10
Scaffolds	3.36	1.051	11
Excavations	3.44	1.046	12
Safe access	3.60	1.018	13
Public protection and information	3.69	0.932	14

Source: Field survey

# **CHAPTER SIX: CONCLUSIONS AND RECOMMENDATIONS**

## **6.1 INTRODUCTION**

This chapter provides the summary of this thesis, research conclusions obtained from conducting this study, and the recommendations.

## **6.2 The Main Conclusions That Could Be Driven From the Study Are:**

- 1- 4% of companies have department to monitor the Occupational Safety and Health. On the same line, 8% of companies care about appointing a trained safety representative on the work site to ensure safety performance and 6% of companies devotes adequate hours to train workers on safety means. On the other hand, 10% of companies discuss safety responsibilities with the owner and consultant.
- 2- In the project planning step, 8% of companies care about putting a clear plan for safety at construction sites. On the same line, 6% of companies claims and asks Contractors to develop a plan for safety in projects at the tender stage and the majority of companies doesn't care about safety issues and doesn't put safety as a priority.
- 3- The majority of the companies that were analyzed have not a professional safety and/or department. On the same line, the participated companies that are not using a safety program or manual represented. It can be concluded that the companies, which have not safety professional or department, are unnecessary mean that are not using a partially safety program or manual.
- 4- The results of this study indicate that the factors at an organization level has a greater impact on the construction industry than the factors at the project level because when the administration develop a plan for safety and provide personnel protective equipment and appoint safety supervisors, safety trainers and safety engineers at the site to oversee the work and the workers and to make necessary tests for devices, equipment and vehicles and to put contingency plan in case of fire will save themselves a lot of costs and time.

- 5- The most important factors affecting the safety performance is personal protective equipment (PPE) and from the study i find that 8% of companies provide PPE for their workers and the majority attributed failure to provide PPE to high cost and instability of their workers and that workers see in wearing this PPE obstruction for their work.
- 6- 4% of respondents do not care about noise pollution factor, which have an impact on employees within the site and off-site to the public and the neighbors even though it occupies the second place in the ranking of safety factors.
- 7- Punishments and Monetary Incentives Non-Monetary Incentives play a big role in making the workers committed to safety instructions. From the study i find that 4% of companies put strict punishments to workers who breaks safety regulation and put incentives to workers who are committed to safety regulations.
- 8- Study found that 4% of companies only resort to insurance their workers and the majority attributed that to the instability of their employment. also in the event of a risk if one of the workers died for example, they are resorting to settle this matter with the family of the worker and they end this matter by paying blood money to the family of the died worker while he's in the law of compensation for work-related injury the law provides in the event of death of the worker, the employer should pay the working daily wages for a period of 900 days in the case of total disability the employer pays the working daily wages for a period of 1260 days. These irregularities indicate the absence of strict laws and legislation in the country which can regulate the movement of work and preserve the safety of workers.

### **6.3 General Recommendations**

- 1- Cooperation between the different official bodies in a common format in order to compel businesses manage healthy and safety.
- 2- Give supervisors the authority and supervision of full and wide in the case of non-compliance with laws and training them on how the application as well as the importance of inspection and control periodically.

- 3- The necessary coordination between the ministry of labor and the federation of workers and the federation of employers and international labor organization to preserve the rights of workers and create the necessary protection for them.
- 4- It is recommended for the company to implement a system for safety incentive for the workers. It may not necessarily be the best tool to enhance safety performance of work site, but some form of incentive is important.
- 5- The provision of skilled labor, education, insurance, and full use of foreign expertise and training.
- 6- Emphases should be laid on investigation the indirect costs of accidents. These costs in addition of being greater than the direct costs, which are usually covered by insurance, they buried into project costs, increasing the cost of construction. The costs of accidents present a serious drain of company's profit. Therefore more attention will be paid to the economic investment in safety if the contractor realizes the fact that the costs of accidents are higher than the cost of safety.
- 7- Establishment of a training course to teach workers all kinds of accident prevention and first aid method and afford them training certification.
- 8- It is recommended to strengthen the awareness and attitude of the top management and project managers towards the importance of safety. The managements of the company must establish and enforce safety polices for workers and should develop their activities by including more monitoring of safety performance at the site and by giving more reliable feedback about the consequences that take place. Companies should hold their project management accountable for accidents
- 9- It is recommended for the concerned government authorities to hire qualified, competent and certified engineers to conduct regular site inspections.
- 10- It is recommended for the company's management to conduct clear safety Policy and periodically random safety inspections for technical works like, fire prevention, crane lifting and scaffolding to ensure the implementation of safety provisions and conditions.
- 11- The government and the engineering societies should play a major role to apply the safety rules by issuing the regulations, standards and codes and legally enforced the companies to follow them with adequate strict penalties for noncompliance.

- 12- The concept of safety, in its broadest sense, should be taught in all stage of education. All media should pay attention to safety rules in all fields.
- 13- The owners and the engineer should enforce the contractor to comply with the safety requirements.
- 14- A safety provision should be stated in construction contracts. It should also be taken into consideration in the tendering stage. An adequate budget should be assessed to safety implementation.
- 15- Tender documents should enclose the safety measures and the signs ought to be used during implementation. Clients should be tight in applying the safety measures and the no. of signs to be used during the implementation phase of any project.
- 16- It is recommended that only experienced workers should be allowed to perform risky tasks, especially when using heavy machinery or powered tools and drive should be provided for new workers since they are the ones who are exposed to the danger of daily job hazards.

### **Recommendation for Future studies:**

- 1- Research can be conducted to find out the role of the owners and the consultants to avoid or mitigate the accidents in construction sites.
- 2- Research can be conducted to estimate the cost of safety and to correlate this cost with the cost of accidents to encourage the companies to take safety seriously.
- 3- Research can be conducted to find out the affect of applying some form of incentives on the construction safety performance.

## REFERENCES

### Books:

- 1- Ahcom, Junaid (2004). A Model for Benchmarking Contractors Project Management Elements in Saudi Arabia , Master thesis, King Fahd University of Petroleum& Minerals, Dhahran, Saudi Arabia.
- 2- Agarwal, P., and Everett, J. (1997). Strategies for Construction Contractors to Reduce Workers Comp. Costs, Journal of Management in Engineering, Vol.13, No. 5, pp. 70-75.
- 3- Aksorn, T. and Hadikusumo, B.H.W. (2008). Critical Success Factors Influencing Safety Program Performance in Thai Constriction Projects, Safety Science, Vol46, pp 709-727.
- 4- Al-Amoudi, W. A. (1997). Assessment of Safety Level in Performing Building Maintenance Work in Saudi Arabia , Master thesis, King Fahd University of Petroleum & Minerals, Dhahran, Saudi Arabia.
- 5- Baig, M. (2001). Safety Assessment of Industrial Construction Projects in Saudi Arabia, Master Thesis, King Fahd University of Petroleum and Minerals, Dhahran, Saudi Arabia.
- 6- Bernard, H.R., Social Research Methods: Qualitative and Quantitative Approaches, Thousand Oaks, Sage Publications, 2000.
- 7- Bourque, L.B. and Fielder, E.P. (1995), How to Conduct Self-Administered and Mail Surveys - The Survey Kit 3, Sage Publications, London, 1995.
- 8- Bu-Khamsin, M. A., (1999). Safety Performance Measurements: A PC Evaluation Tool for Industrial Contractor in Saudi Arabia, Master thesis, King Fahd University of Petroleum & Minerals, Dhahran, Saudi Arabia.
- 9- Carmines, E. G. and Zeller, R. A., Reliability and Validity Assessment, Sage Publications, Beverly Hills, 1979.
- 10- Chua, D.K., and Goh, Y.M. (2004). Incident Causation Model for Improving Feedback of Safety Knowledge, Journal of Construction Engineering and Management, Vol. 130, No. 4, pp. 542-551.
- 11- Cronbach, L. J., Coefficient alpha and the internal structure of tests, Vol. 16 No. 3, 1951, September, pp. 297-334.
- 12- Eckenfelder, D.J., (1997). It is the Culture Stupid, Occupational Hazards. June 1997. pp. 41-44.

- 13 - Enshassi, A., (2003), Factors Affecting Safety on Projects Construction, CIB Working Commission W99, Brazil.
- 14- Fang. D. Huang, X., and Hinze, J., (2004). Benchmarking Studies on Construction Safety Management in China, *Journal of Construction Engineering and Management*, Vol. 130, No. 3, pp. 424-432.
- 15- Fang. D. P., Xie, F., Huang, X. Y., and Li, H. (2004). Factor Analysis-Based Studies on Construction Workplace Safety Management in China, *International Journal of Project Management*, Vol. 22, No. 1, pp. 43-49.
- 16- Fung, Ivan W.H., Tam, C.M. Tung, Karen C.F., and Man, Ads S.K (2005)..”Safety Cultural Divergences among Management, Supervisory a Worker Groups in Hong Kong Construction Industry, *International Journal of Project Management*, Vol. 23, No. 7, pp. 504-512.
- 17-Hatush, Z., and Skitmore, M. (1997). Criteria for Contractor Selection, *Construction Management & Economics*, Vol.15, No. 1, pp. 19-38.
- 18- Hair, J.F., Jr., Anderson, R.E., Tatham, R.L. and Black, W.C., *Multivariate Data Analysis with Readings*, 3rd edition, Macmillan Publishing Company, New York, 1992.
- 19- Hammer. W. (1985). *Occupational Safety Management and Engineering*, Prentice- Hall,Ina, Englewood Clifffis, New Jersey.
- 20- Hassan, C.R., Basha, O.J., Hanafi W.H. (2007). Perception of Building Construction Workers towards Safety, Health and Environment, *Journal of Engineering Science and Technology*, Vol. 2, No. 3, pp. 271-279.
- 21- Hinze, J., and Gambatese, J., (2003). Factors that Influence Safety Performance of Specialty Contractors, *Journal of Construction Engineering and Management*, Vol. 129, No. 2, pp. 159-164.
- 22- Hinze, J., and Raboud, P., (1988). Safety on Large Building Construction Projects, *Journal of Construction Engineering and Management*, Vol. 114, No. 2, pp. 286-293.
- 23- Hinze, J., and Wiegand, F., (1992). Role of Designers in Construction Worker Safety, *Journal of Construction Engineering and Management*, Vol. 118, No. 4, pp. 677-684.

- 24- Hislop, R.D., (1999). *Construction Site Safety – A guide for managing contractors*, Florida, Lewis Publishers, Boca Raton.
- 25- *Improving Construction Safety Performance* (1982). Report A-3, Business Round table, <http://www.curt.org/pdf/135.pdf>.
- 26- Jannadi, O.M., (1995). Impact of human relations on the Safety of Construction workers, *Journal of Project Management*, Vol. 13, No. 6, pp. 383-386.
- 27- Jannadi, O.M., (2008). Risks Associated With Trenching Works in Saudi Arabia, *Journal of Building and Environment*, Vol 43, pp. 776–781.
- 28- Jannadi O.M., and Bu-Khamsin, M. S., (2001). Safety Factors Considered By Industrial Contractors in Saudi Arabia, *Journal of Building and Environment*, Vol 37, No.(5), pp. 539–547.
- 29- Kartam, N., and Bouz, R., (1998). Fatalities and Injuries in the Kuwaiti Construction Industry, *Journal of Accident Analysis and Prevention*, Vol. 30, No. 6, pp. 805-814.
- 30- Kartam, N., Flood, I. and Koushki, P., (2000). Construction Safety in Kuwait: Issues, Procedures, Problems, and Recommendations, *Journal of Safety Science*, Vol. 36, No. 3, pp. 163-184.
- 31- Kemp, R.G.M., *Managing Interdependence for Joint Venture Success: An Empirical Study of Dutch International Joint Ventures*, PhD thesis, Faculty of Management and Organization, University of Groningen, The Netherlands, 1999.
- 32- Koehn, E., Kothari, R.K., and Pan, C-S., (1995). Safety in Developing Countries: Professional and Bureaucratic Problems, *Journal of Construction Engineering and Management*, Vol. 121, No. 3, pp. 261-265.
- 33- Litwin, M. S., *How to Measure Survey Reliability and Validity*, Sage Publications, Thousand Oaks, 1995.
- 34- Mattila, M., Hyttinen, M., and Rantanen, E., (1994). Effective Supervisory Behavior and Safety at the Building Site, *International Journal of Industrial Ergonomics*, Vol. 13, No. 2, pp. 85-93.
- 35- Mohamed, S. (2002). Safety Climate in Construction Site Environments, *Journal of Construction Engineering and Management*, Vol. 128, No. 5, pp375-384.
- 36- Nunnally, J., *Psychometric Theory*, New York, McGraw-Hill, Inc, 1967.

- 37- Ng, S.T., Cheng, K.P., and Skitmore R.M. (2005). A Framework for Evaluating the Safety Performance of Construction Contractors, *Building and Environment*, Vol. 40, No. 10, pp. 1347-1355.
- 38- Occupational Safety and Health Administration, (1990). *Excavations*, OSHA Publication, 2226, US Department of Labor.
- 39- OSHA 2202 (2002). *Construction Industry Digest*, Occupational Safety and Health Administration (OSHA),  
<http://www.osha.gov/Publications/osha2202.pdf>
- 40- Patton, M.Q., *Qualitative Evaluation And Research Methods*, 2nd edition, Sage Publications, Newbury Park, London, 1990.
- 41- Petersen, D., (1971). *Techniques of Safety Management*, McGraw-Hill, Book Company.
- 42- Permana, I.E., (2007). *Construction Safety Practices In Batam, Indonesia*, Master Thesis. University of Technology, Malaysia.
- 43- Punch, K.F., *Developing Effective Research Proposals*, SAGE Publications, London, 2000.
- 44- Reese, C.D., (2003). *Occupational Health and Safety Management: A Practical Approach*, Lewis Publishers.
- 45- Sawacha, E., Naoum S., and Fong, D. (1999). Factors Affecting Safety Performance on Construction Sites , *International Journal of Project Management*, Vol. 17, No. 5, pp. 309-315.
- 46- Tam, C.M., Zing, S.X., and Deng, Z.M. (2004). Identifying Elements of Poor Construction Safety Management in China, *Safety Science*, Vol. 42, No. 7, pp. 569-586.
- 47- Tam , C.M., Fung, I.W.H., Yeung ,T.C.L. and Tung, K.C.F. (2003). Relationship Between Construction Safety Signs and Symbols Recognition and Characteristics of Construction Personnel, *Construction Management and Economics*, Vol 21, 745–753.
- 48- Teo, E.A.L., Ling, F.T.Y., and Chong, A.F.W. (2005). Framework for Project Managers to Manage Construction Safety, *International Journal of Project Management*, Vol. 23, No. 4, pp. 329-341.
- 49- Xie, J.Y, and Li, X.J. (1999). *Employees' Safety and Health*. Beijing: Economy Management Publishing House.

50- Yassin A.S. and Martonik J.F., (2004). The Effectiveness of the Revised Scaffold Safety Standard in the Construction Industry, Journal of Safety Science, Vol 42, pp. 921–931.

51- Yin, R.K., Case Study Research: Design And Methods, Revised edition, Sage Publications, London, 1989

## المراجع العربية

### الكتب :

52- الفرا , وليد عبدالرحمن خالد , تحليل بيانات الاستبيان باستخدام البرنامج الإحصائي

SPSS, الندوة العالمية للشباب الإسلامي , 1430 هـ .

53- حسين, هشام بركات بشر , تحليل البيانات باستخدام برنامج الحزمة الإحصائية للعلوم

الإجتماعية , دار النشر الإلكتروني , القاهرة , 2007م.