

3.1 INTRODUCTION

This chapter shows the structure of the salary system case study and the tasks comprising it. It also shows the analysis of SUT using UML diagrams.

3.2 SYSTEM UNDER TEST OBJECTIVES

1. The main objective is to calculate the settlements of salary for a large number of employees of different categories.
2. Calculate salaries in much less time than the traditional manual ways.
3. Showing and printing the calculated results in form of an Excel sheet helps dealing with banks.
4. Automatic deductions and premiums make it easier to manage salaries.
5. Organizing workers into different categories and classes make it easier to deal with employees and with their data.
6. Calculate deductions automatically in a programmed manner called "Programmed deductions ".
7. Add dues automatically in a programmed manner called "Programming dues ".
8. Sorting information by colleges make it easier to deal with the bank where all employee's account information are sent for specific college.
9. The system has an additional characteristic that generalize deductions and premiums to all employees per faculty or to all faculties at once.
10. Easy to modify and change employee's information and data for all categories (Ex. Promotions).
11. Easy to extract reports (according to premium or deduction).
12. Extract salary certificate.
13. Extract operation details that have happened per faculty or to all faculties.
14. Extract a summary for operations to make it easier to review.

3.3 SALARY CALCULATION PROCESS

The payroll is prepared at the end of each month by deporting it to the ledger; from there all the calculations and processes are being done for a particular college to a particular category of employees and then save the final modification at the end of salary calculation processes. Each employee has a unique and distinguish number and each salary is affected by two factors “premiums and deductions”.

There are many types of deductions performed on the employee's salary; classified into fields in form of a table with those deductions and it's calculated in the first half of the salary “Deduction must not done at the two parts of the salary, where the system stops and never calculate deduction”. Deduction is to deduct financial amount from the salary, the system will deduct from the salary automatically each month by identifying the number of months and the amount needed to deduct according to the equation: Deduction= the whole amount to be deducted divided to the number of months.

There are also several categories of premiums that are also in the form of scheduled fields, and there is the possibility to add new types of premiums to the table. The premiums are modified in the main salary, such as retired pay and health insurance.

The calculation of salary for each employee is done according to the following equation:

salary = main salary + total premiums - total deductions.

3.4 SYSTEM UNDER TEST ANALYSIS

Application analysis was carried through using UML technology. The following part contains a brief explanation of what it is and the diagrams showing the actual analysis.

3.4.1 USE CASE DIAGRAM

The figure (3.1) bellow shows the operation that can done by user.

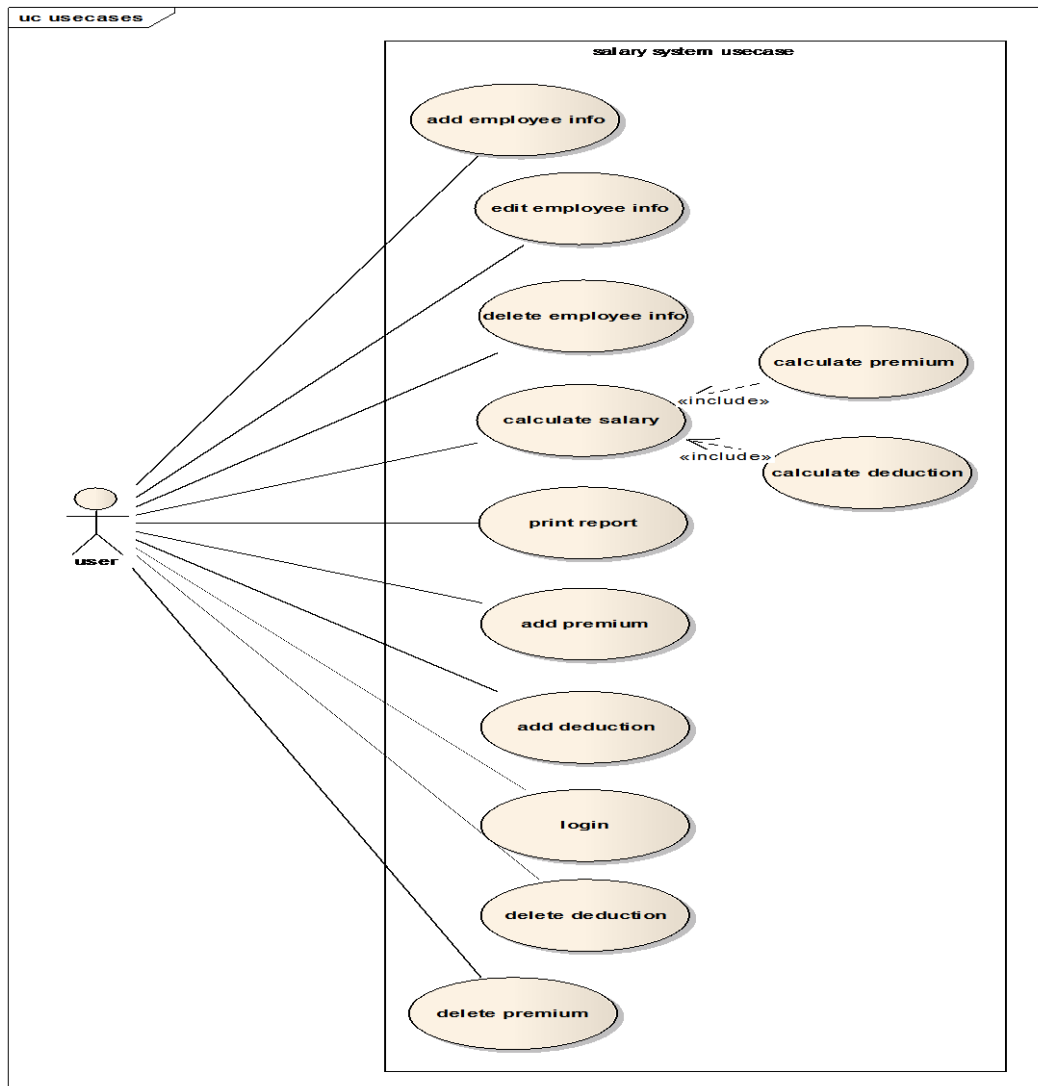

— Figure (3.1) Use case diagram

3.4.2 CLASS DIAGRAM

The figure (3.2) bellow shows the classes of the system, relationships among them and the main class (salary) that will be tested in chapter 4.

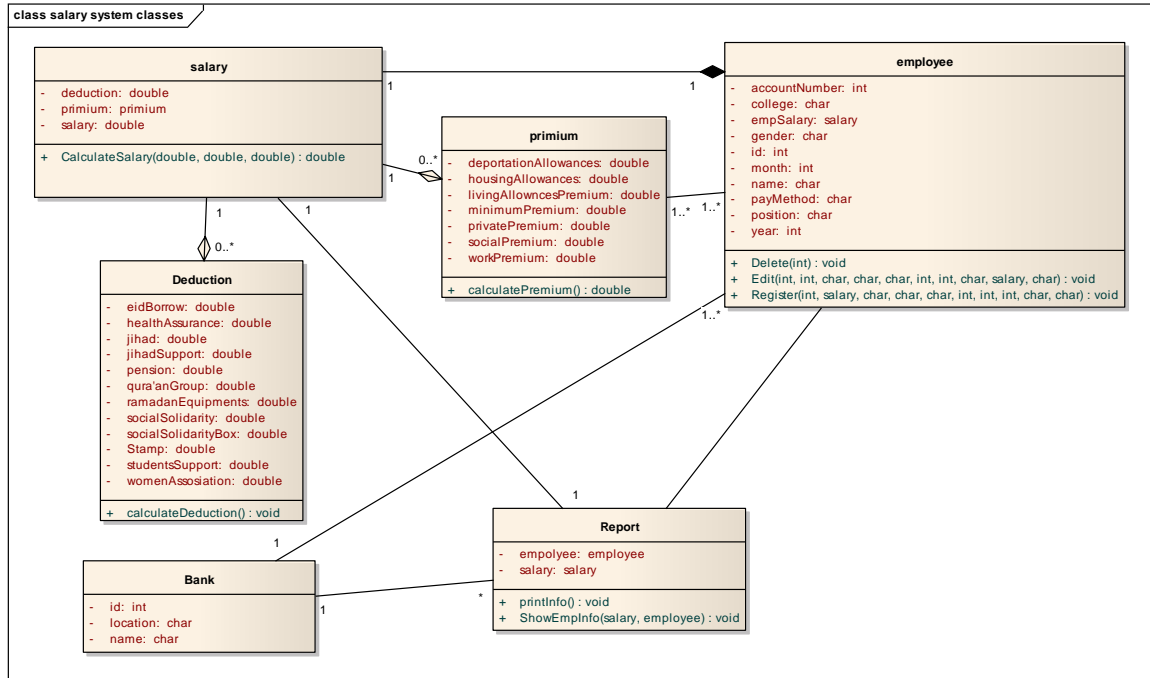

— Figure (3.2) class diagram

3.4.3 SEQUENCE DIAGRAM

—3.4.3.1 LOGIN SEQUENCE DIAGRAM

— Figure (3.3) below shows the login sequence diagram of the SUT.

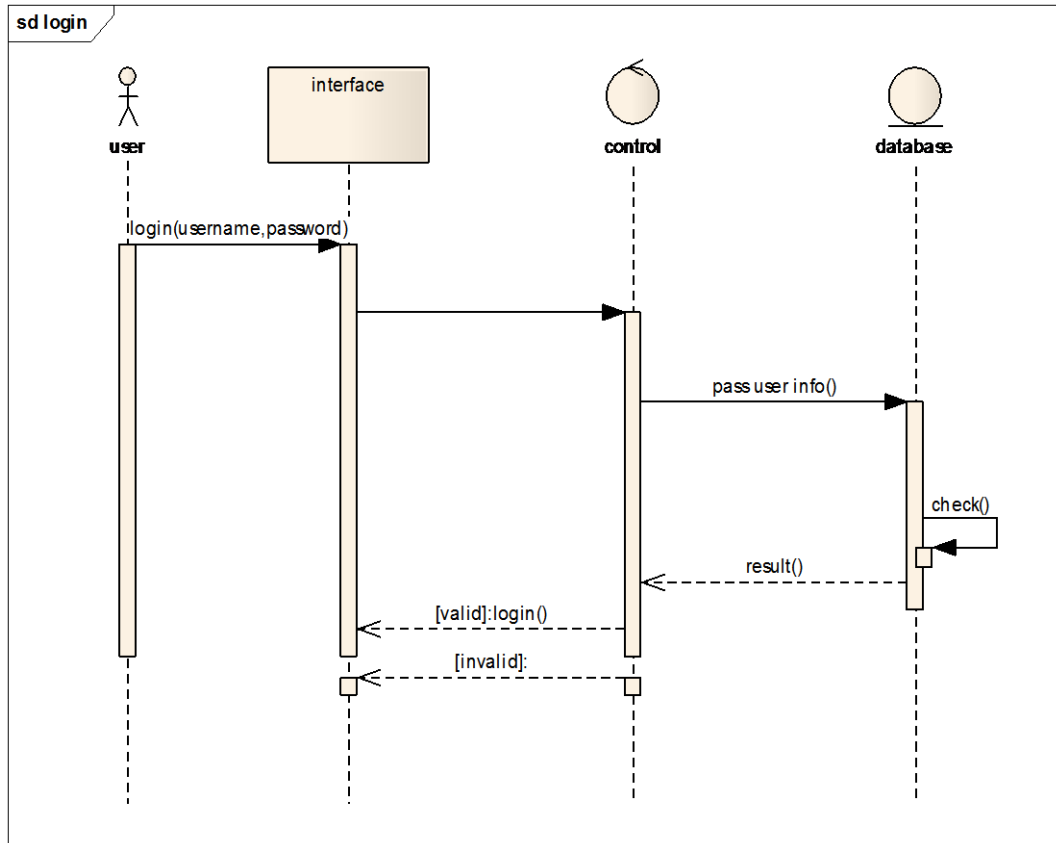

— Figure (3.3) Login sequence

—3.4.3.2 ADD DEDUCTION SEQUENCE DIAGRAM

— Figure (3.4) below shows adding a new deduction sequence diagram of the SUT.

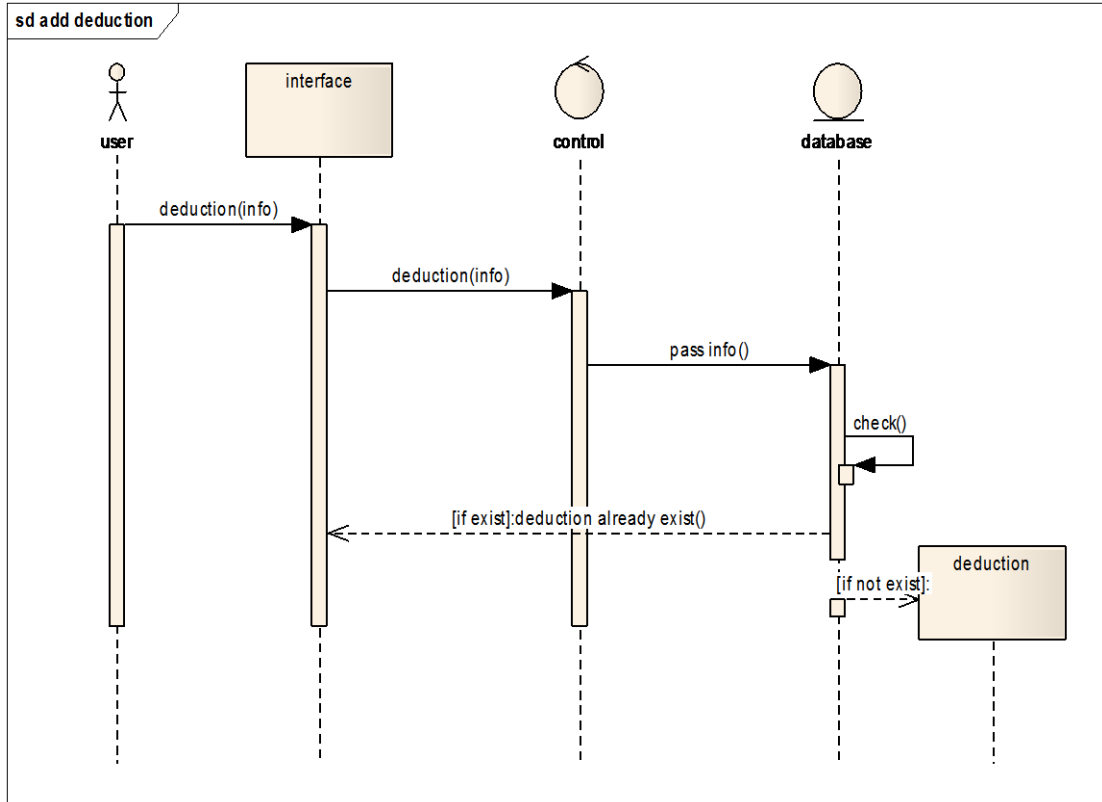

— Figure (3.4) add deduction sequence

—3.4.3.3 ADD EMPLOYEE SEQUENCE DIAGRAM

— Figure (3.5) below shows adding a new employee sequence diagram of the SUT.

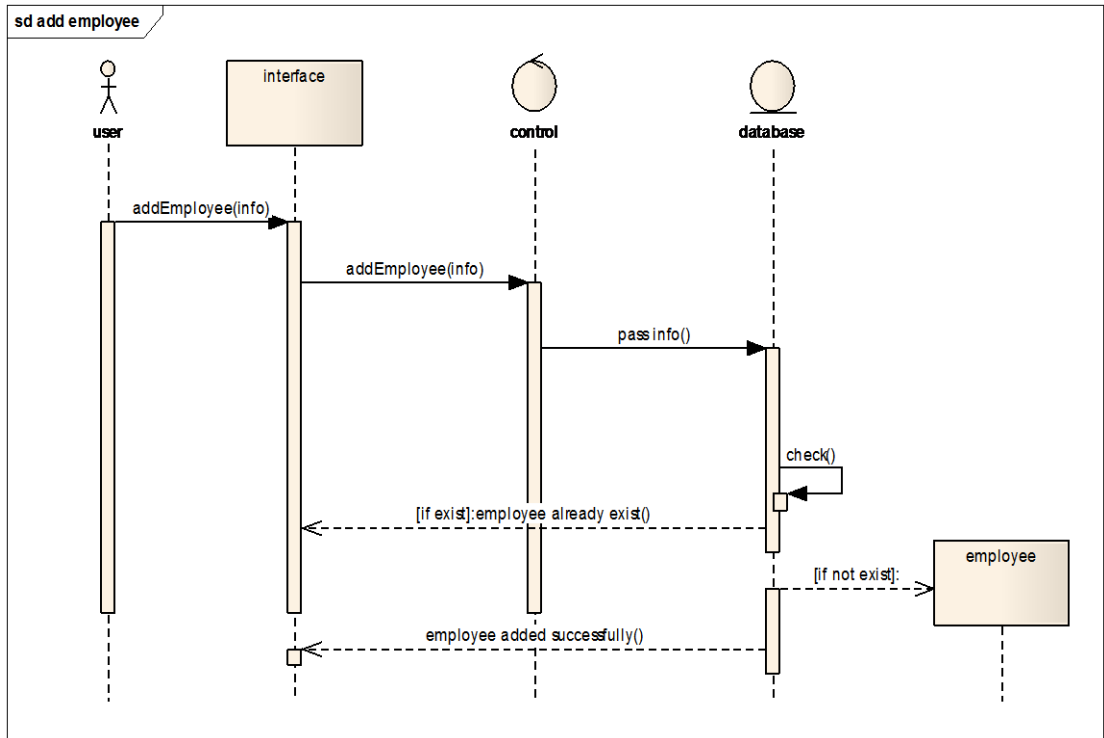

— Figure (3.5) add employee sequence

—3.4.3.4 ADD PREMIUM SEQUENCE DIAGRAM

— Figure (3.6) below shows adding a new premium sequence diagram of the SUT.

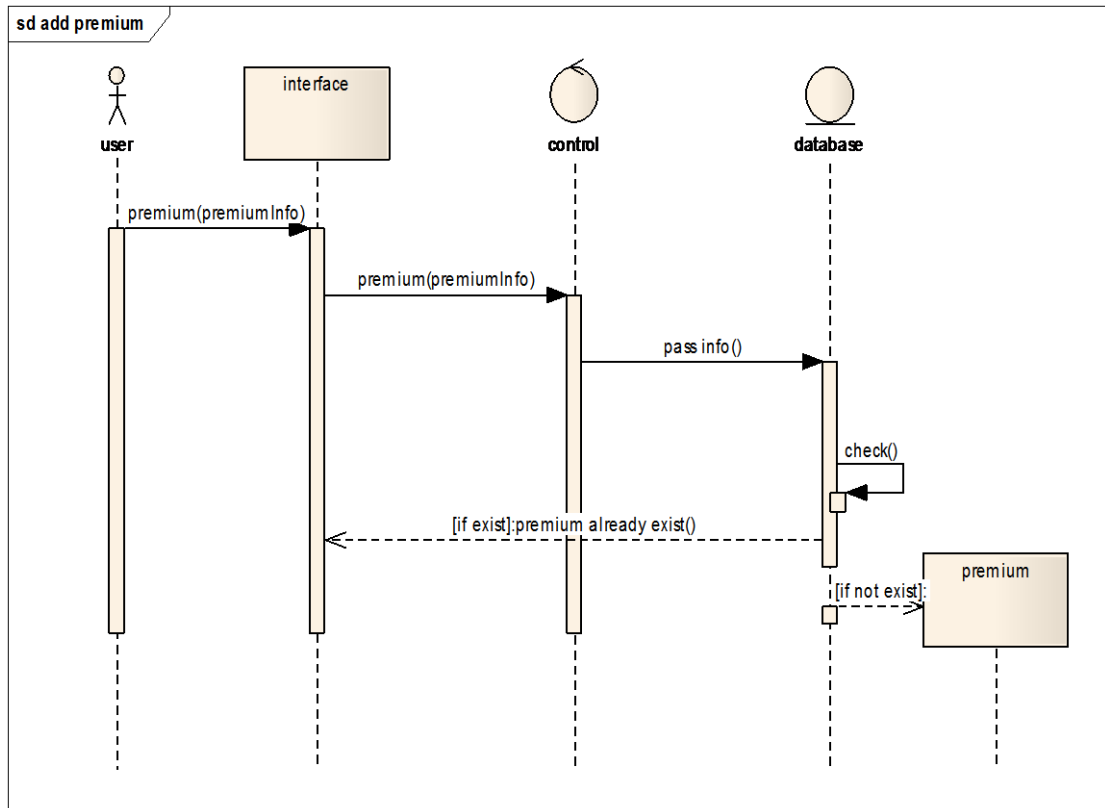

— Figure (3.6) add premium sequence

—3.4.3.5 CALCULATE SALARY SEQUENCE DIAGRAM

— Figure (3.7) below shows calculate salary sequence diagram of the SUT.

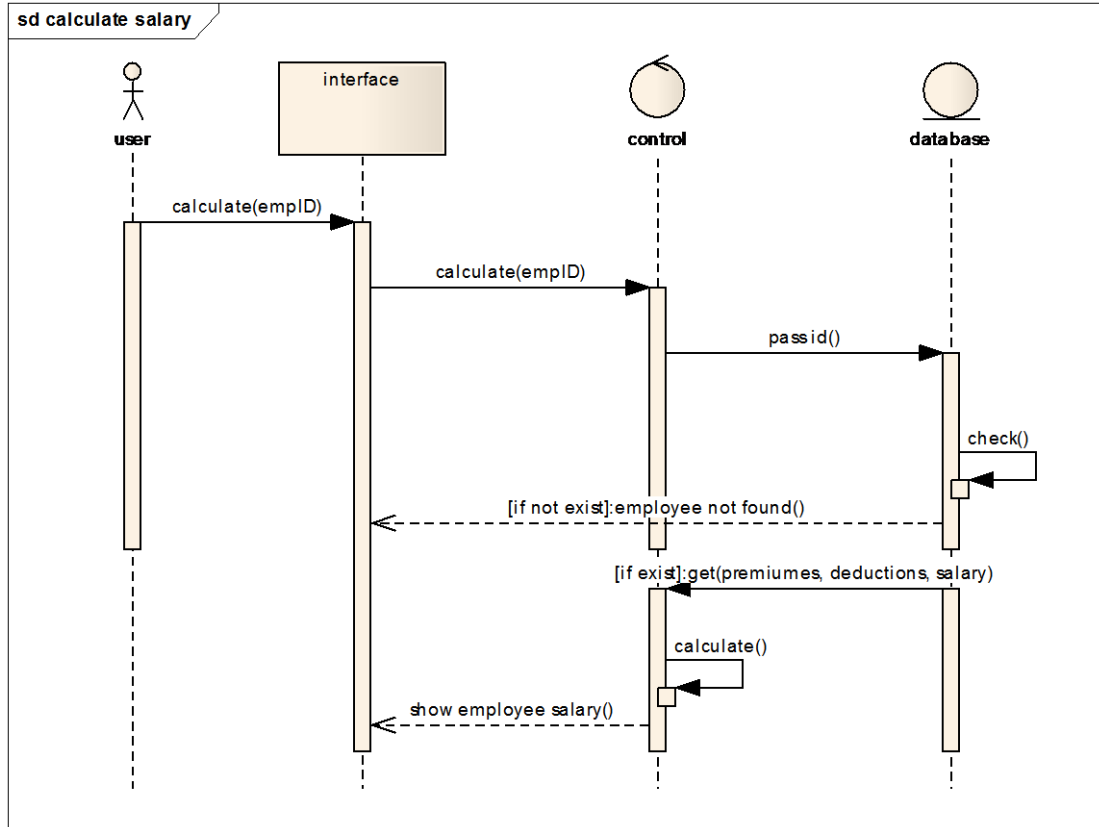

— Figure (3.7) calculate salary sequence

—3.4.3.6 DELETE PREMIUM SEQUENCE DIAGRAM

— Figure (3.8) below shows deletion a premium sequence diagram of the SUT.

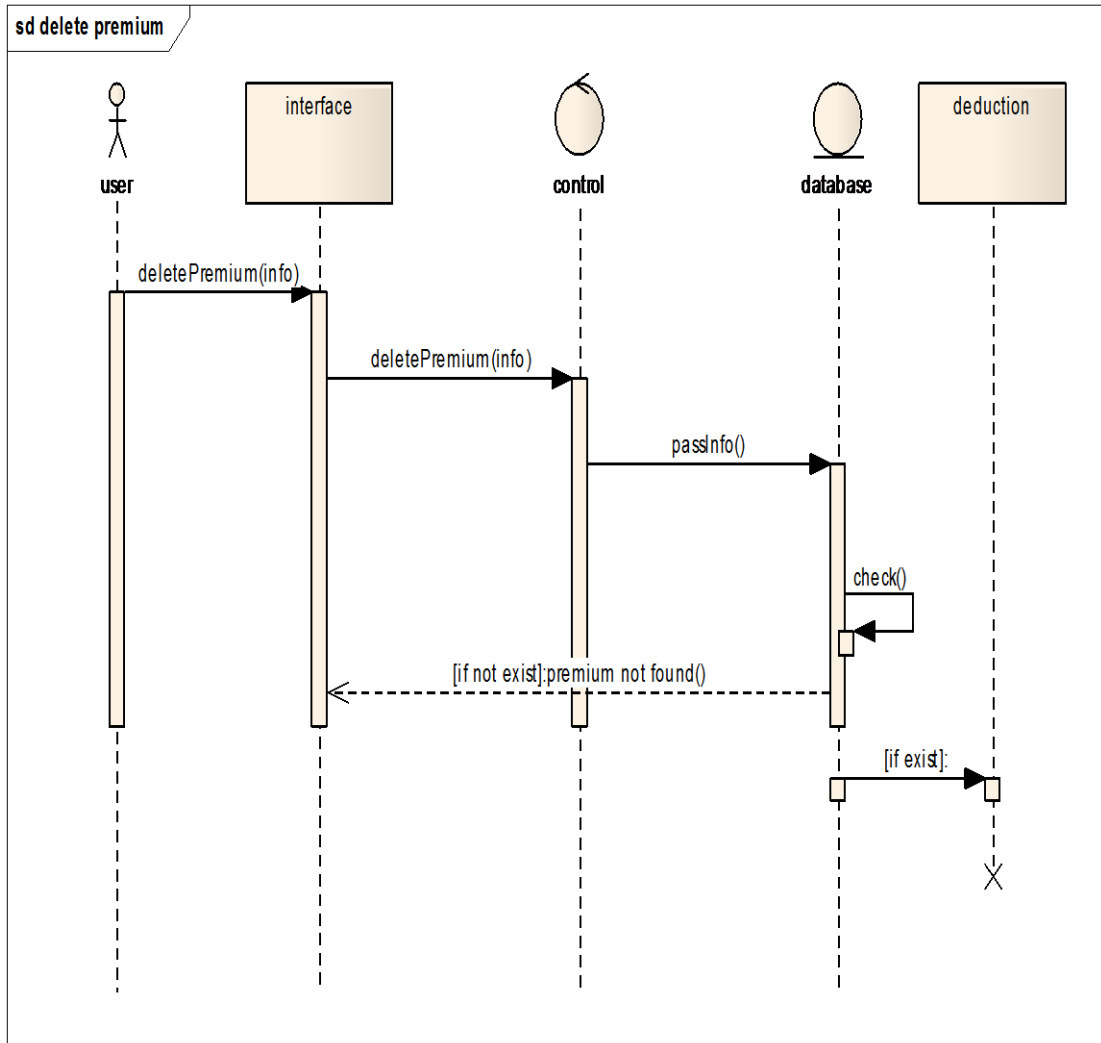

— Figure (3.8) delete premium sequence

—3.4.3.7 DELETE DEDUCTION SEQUENCE DIAGRAM

— Figure (3.9) below shows deletion a deduction sequence diagram of the SUT.

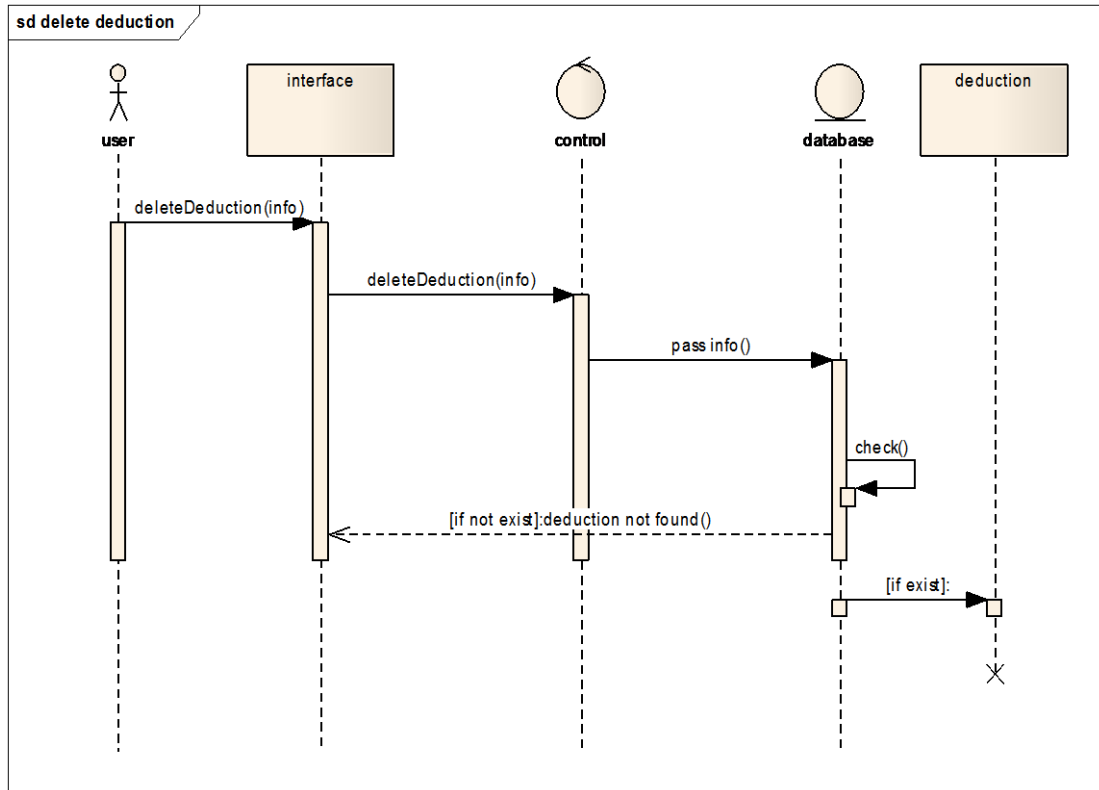

— Figure (3.9) delete deduction sequence

—3.4.3.8 DELETE EMPLOYEE SEQUENCE DIAGRAM

— Figure (3.10) below shows deletion an employee sequence diagram of the SUT.

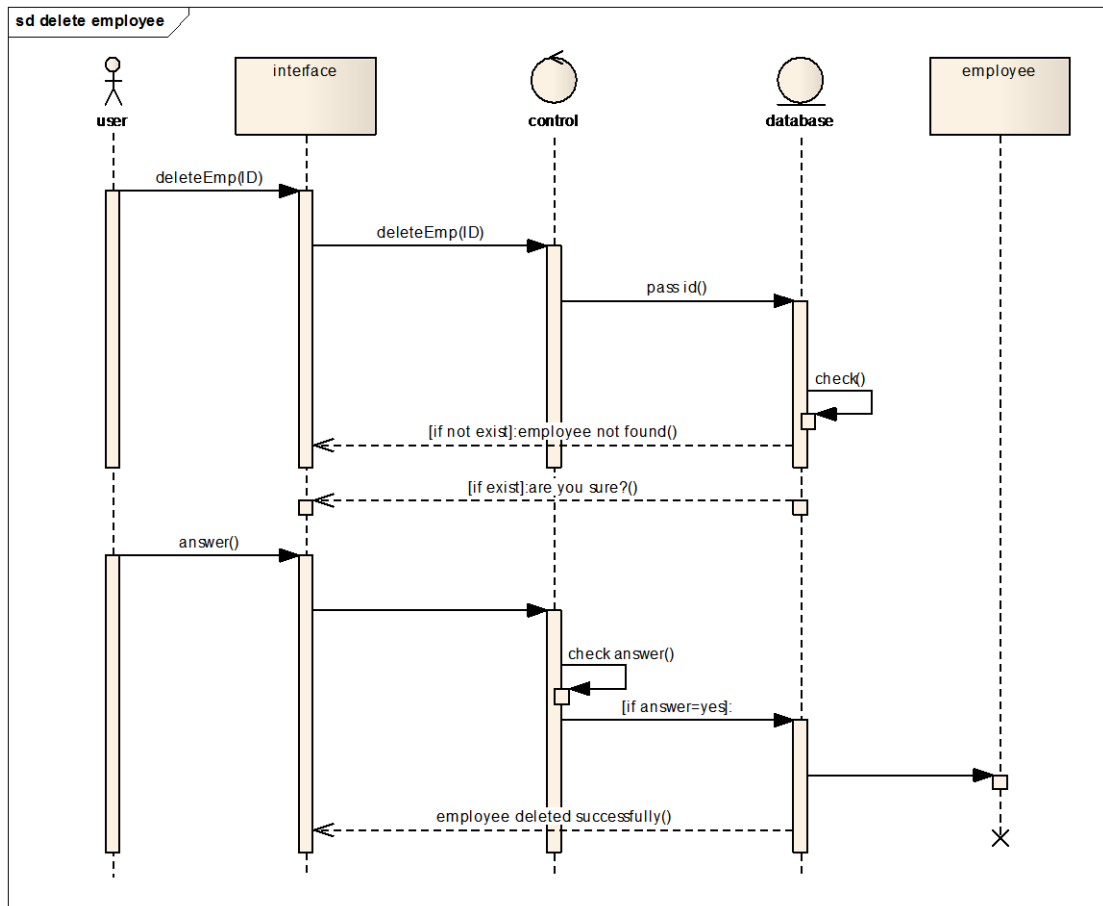

— Figure (3.10) delete employee sequence

—3.4.3.9 EDIT EMPLOYEE INFO SEQUENCE DIAGRAM

— Figure (3.11) below shows edition an employee sequence diagram of the SUT.

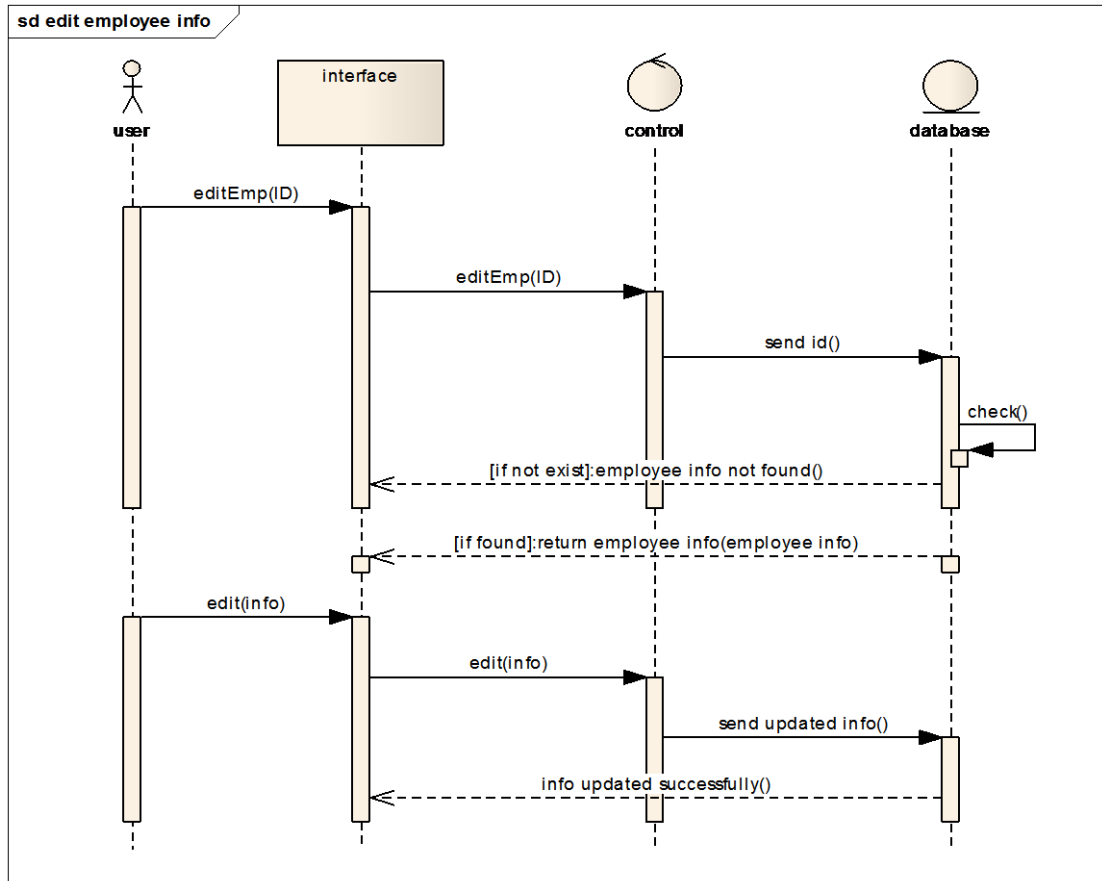

— Figure (3.11) edit employee sequence

—3.4.3.10 SHOW EMPLOYEE INFO SEQUENCE DIAGRAM

— Figure (3.12) below shows show employee info sequence diagram of the SUT.

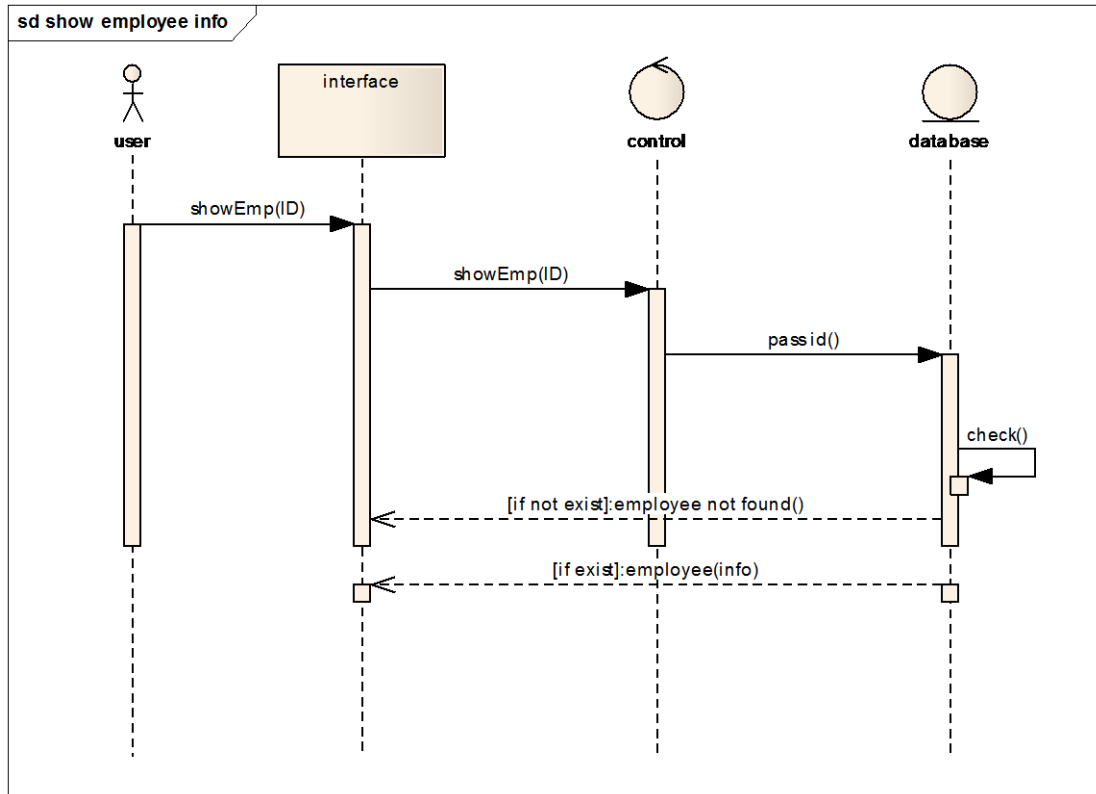

— Figure (3.12) show employee info sequence

3.4.4 ACTIVITY DIAGRAM

—3.4.3.1 EMPLOYEE OPERATIONS ACTIVITY DIAGRAM

— Figure (3.13) below shows employee operations activity diagram of the SUT.

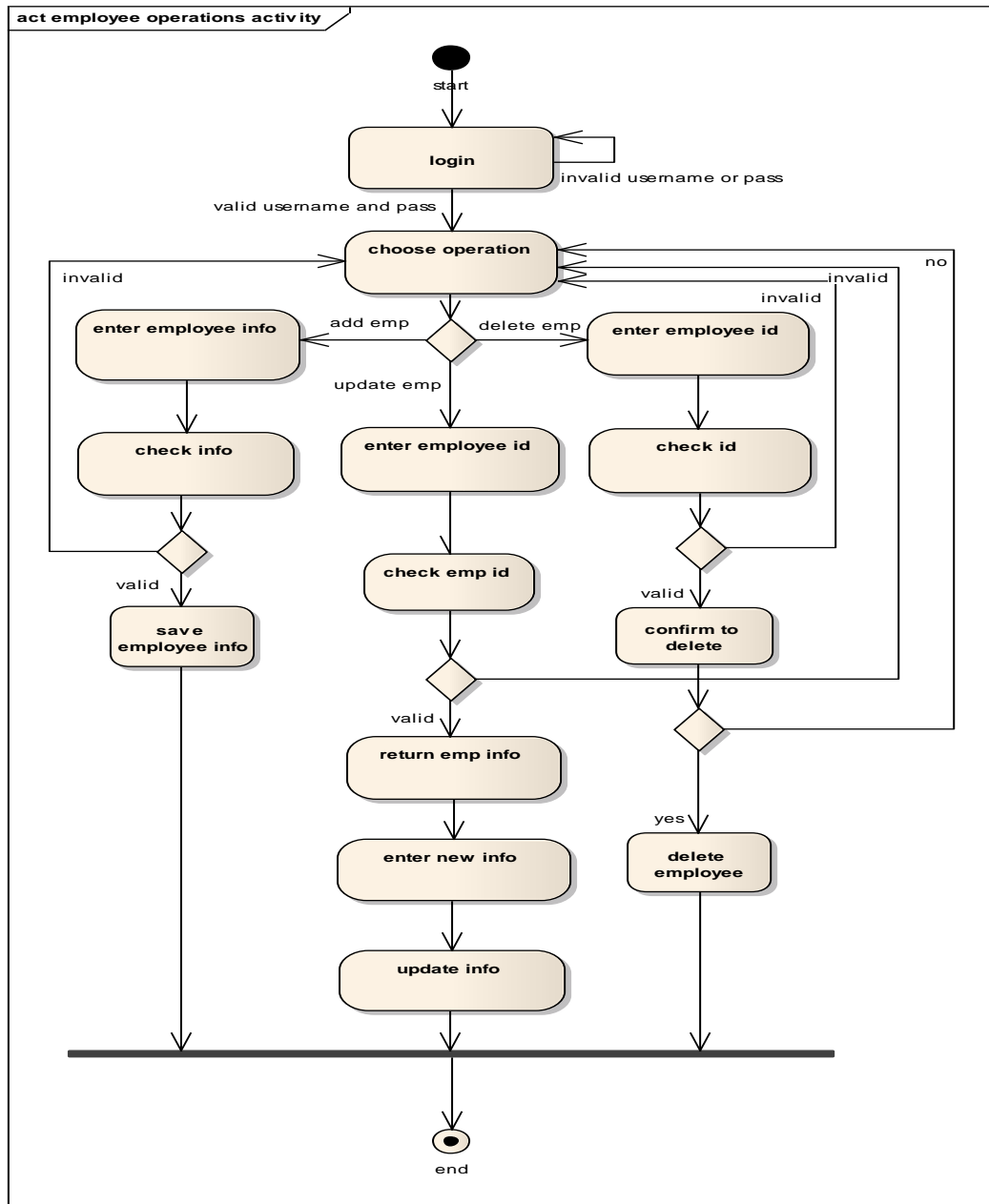

— Figure (3.13) show employee operations activity

—3.4.4.2 PREMIUM AND DEDUCTION OPERATIONS ACTIVITY DIAGRAM

— Figure (3.14) below shows premium and deduction operations activity diagram of the SUT.

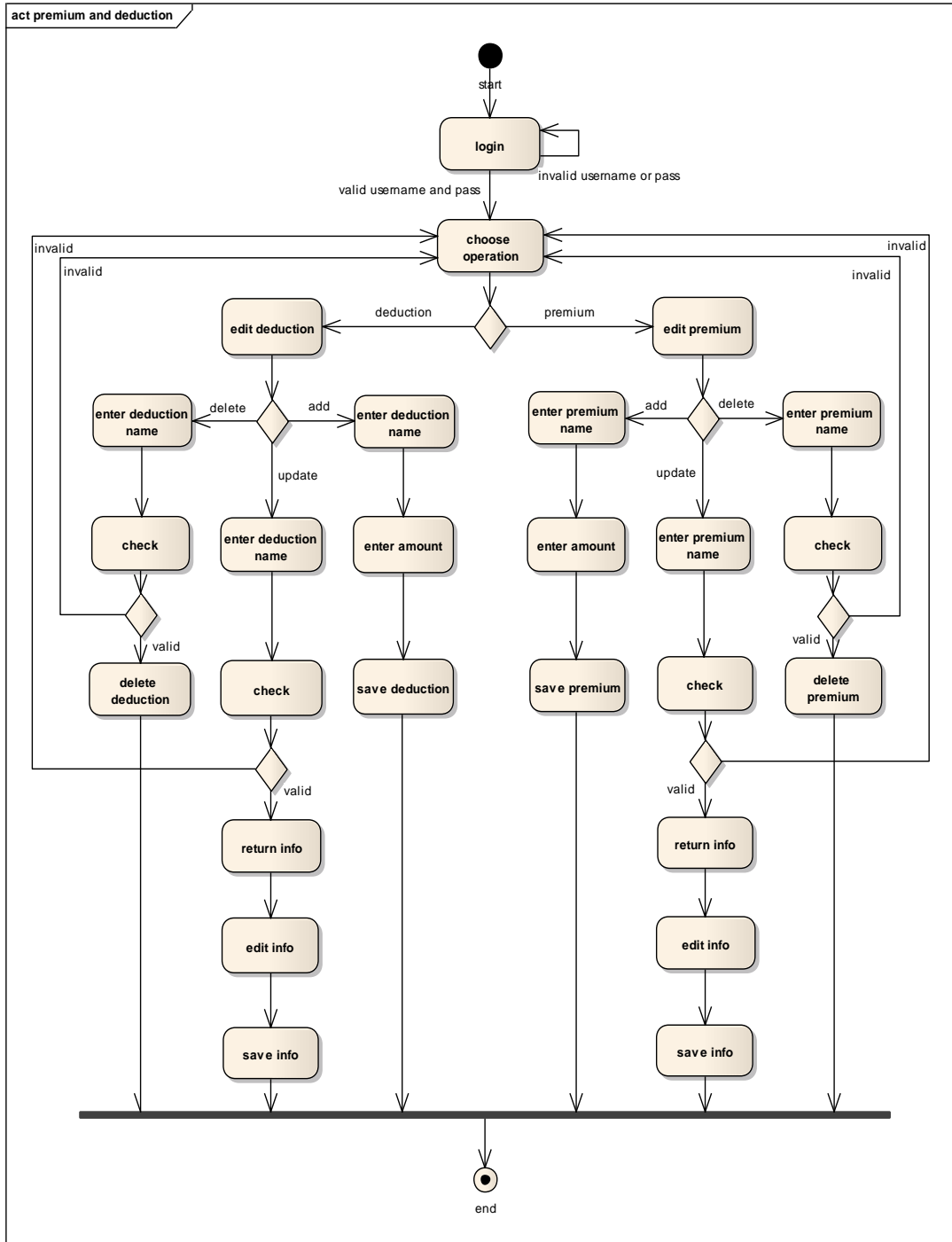
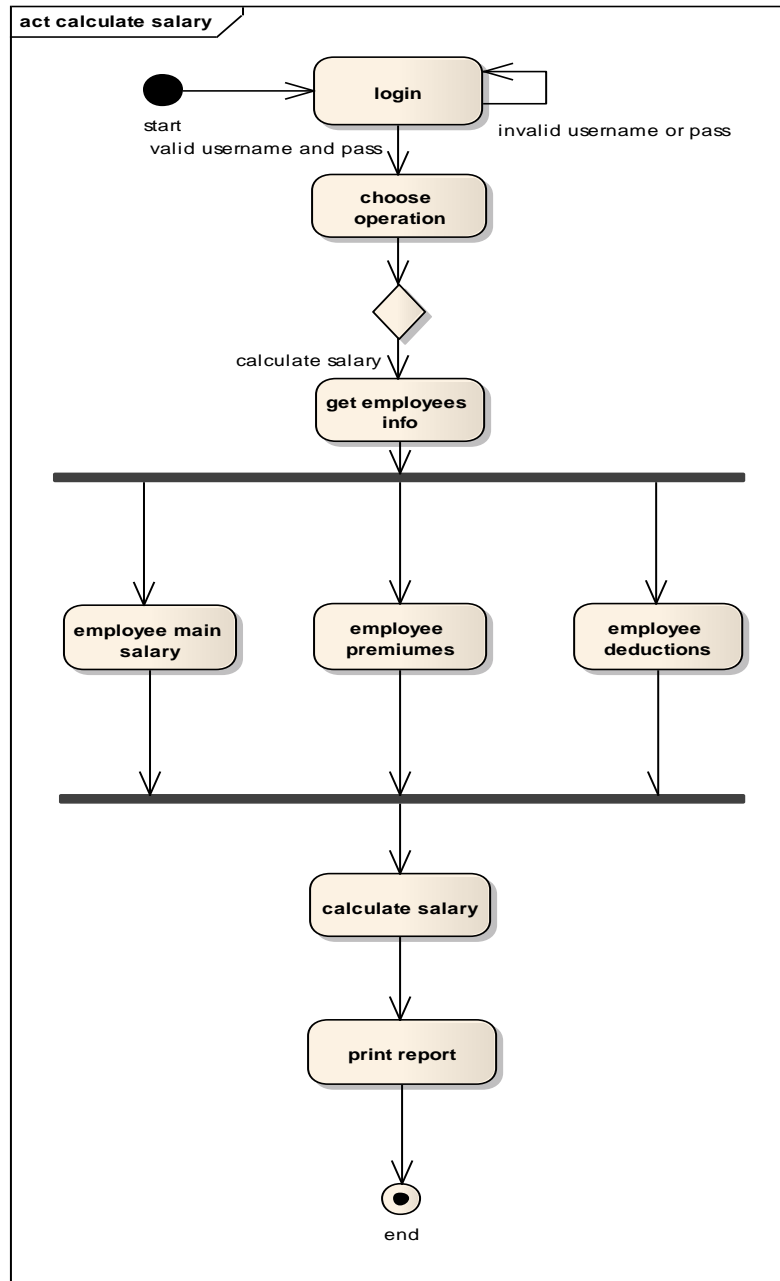

Figure (3.14) show employee operations activity

—3.4.4.3 SALARY CALCULATION OPERATION ACTIVITY DIAGRAM

— Figure (3.15) below shows salary calculation operation activity diagram of the SUT.



— Figure (3.15) show employee operations activity

3.4.5 STATE MACHINE DIAGRAM

—3.4.5.1 SUT STATE MACHINE

— Figure (3.16) below shows state machine diagram of the SUT.

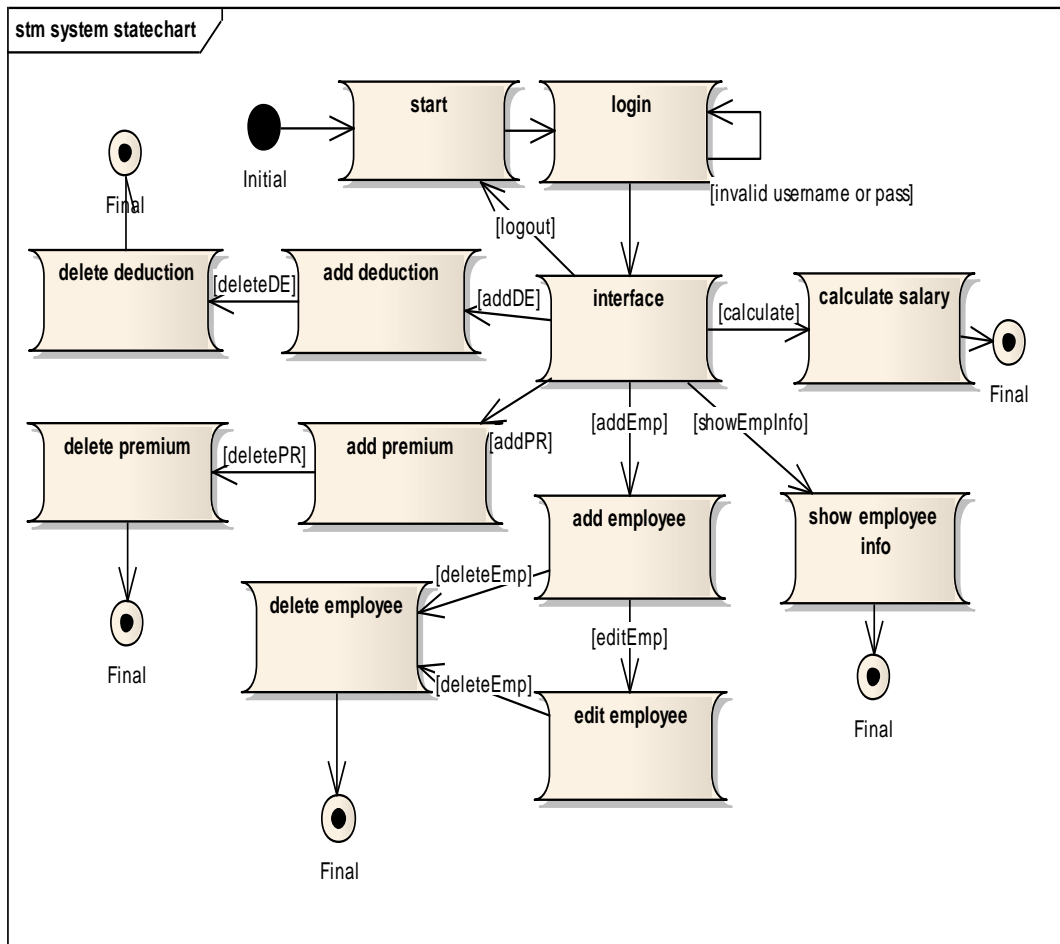

— Figure (3.16) finite state machine (FSM)

3.5 CONCLUSION

This chapter showed the main structure of the application and the analysis of the SUT using UML diagrams by Enterprise architect tool.

The fourth chapter will explain model-based testing process and the way of implementation the test.