

ELECTRICAL AND WATER SUPPLY
SCALE 1:500

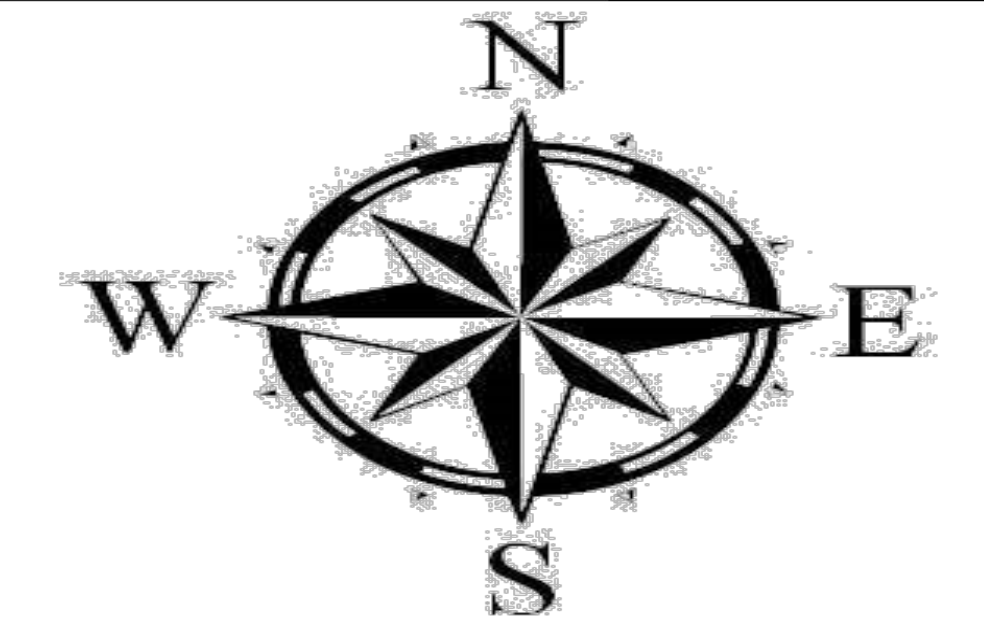

REMARKS

ALL Dimensions by Metric units

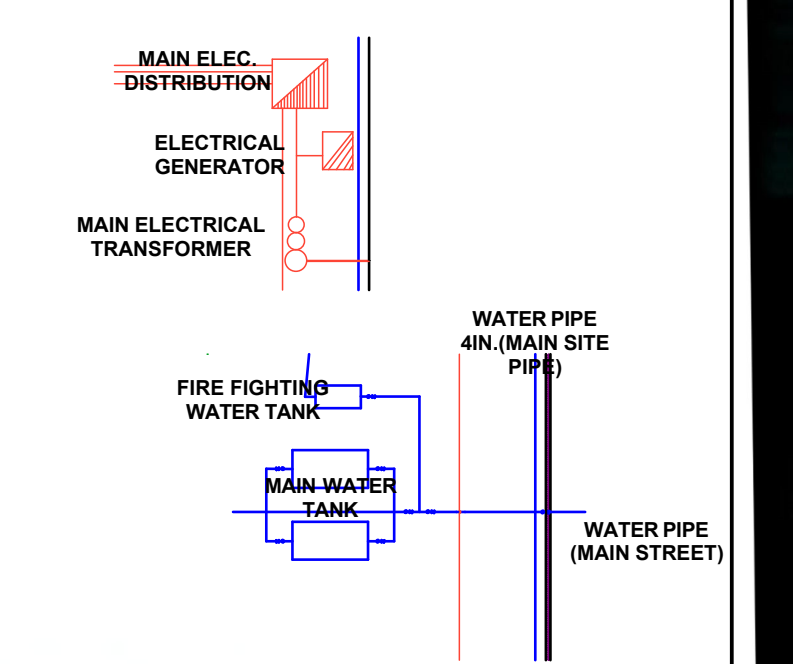

SYMBOLS:

LANDSCAPE WATER OVER FLOW	
SLOPE TOWARD	
MAIN GUTTER	

LENGTH	WIDTH	DEPTH	NAME	LENGTH	WIDTH	DEPTH	NAME
100	75	145	M3	75	57	75	MH1
100	75	175	M4	100	75	105	MH2
125	80	205	M5	100	75	135	MH3
125	80	235	M6	100	75	165	MH4
125	80	265	M7	125	80	195	MH5
125	80	295	M8	125	80	225	MH6
45	45	45	M1-	125	80	255	MH7
75	57	55	M2-	45	45	45	MH1-
75	57	85	M3-	75	57	75	MH2-
100	75	115	M4-	100	75	105	MH3-
100	75	145	M5-	100	75	135	MH4-
100	75	175	M6-	100	75	165	MH5-
125	80	205	M7-	125	80	195	MH6-
125	80	235	M8-	125	80	225	MH7-
125	80	265	M9-	125	80	255	MH8-
125	80	295	M10-	125	80	265	MH9-
125	80	325	M11-	75	57	85	M1
125	80	335	M12-	100	75	115	M2

SUDAN UNIVERSITY OF SCIENCE AND TECHNOLOGY
COLLEGE OF ARCHITECTURE AND PLANING
5th YEAR BACHELOR
ISRA MOHAMMED HASSAN ALI
PROJECT:CHILDREN SCIENCE CLUB
ELECTRICAL AND WATER SUPPLY
SCALE 1:500