



**Sudan University of Science and
Technology
College of Graduate Studies**



Impact of Natural Oils on Solar Panels Efficiency

**A thesis submitted for the Partial Fulfillment of the Requirements of M.Sc.
Degree in Solid State Physics**

أثر الزيوت الطبيعية على كفاءة الخلايا الشمسية

Prepared by:

Tasneem Mohamed Omer Berima

Supervisor

Dr. Amel Abdallah Ahmed Elfaki

April.2021

الآية

قال تعالى: (فَتَعَالَى اللَّهُ الْمَلِكُ الْحَقُّ وَلَا تَعْجَلْ بِالْقُرْآنِ مِنْ قَبْلِ أَنْ يُقْضَىٰ إِلَيْكَ وَحْيُهُ وَقُل رَّبِّ زِدْنِي عِلْمًا)

سورة طه الاية (114)

Acknowledgments

First of all I'm very grateful to **God** who made this all possible, and I would like to dedicate this thesis to my lovely family and my supportive friends. I would also like to acknowledge my supervisor Dr.Amel Abdallah Ahmed Elfaki, Dr.Ali Sulaiman Mohamed and everyone who played a role in this thesis for their patience, guidance and professional advices.

Abstract

This research aims to study the effect of natural oils on the performance of the solar cells after coating the front surface of the cell with a thin layer of oil. Three types of natural oils were used; sesame oil, wheat germ oil and almond oil. The experimental setup consists of solar panel, an artificial sun, and a measuring system (voltmeter and ammeter) to measure the performance of the panel. First, the background results of current and voltage readings without applying oils to the cell were recorded in tables and graphs using Origin graphing program. From the graphs, the maximum current and voltage were set. Also the value of open circuit voltage and short circuit current were set. Then by applying the equations of solar cell, the value of the maximum power and hence the efficiency of the cell were calculated. The same steps were repeated after applying oils, each one separately. The obtained results showed a reduction in the efficiency of the panel except for the wheat germ oil; the efficiency increased compared to the background efficiency.

المستخلص

يهدف هذا البحث إلى دراسة تأثير الزيوت الطبيعية على أداء الخلايا الشمسية بعد طلاء السطح الأمامي للخلية بطبقة رقيقة من الزيت. تم استخدام ثلاثة أنواع من الزيوت الطبيعية ؛ زيت السمسم وزيت جنين القمح وزيت اللوز. تكونت التجربة من لوح شمسي ، وشمس اصطناعية ، ونظام قياس (فولتميتر وأميتير) لقياس أداء اللوحة. أولاً ، تم تسجيل قراءات الجهد و التيار بدون تطبيق الزيت على الخلية ومن ثم رسمها بيانيا باستخدام برنامج اورجن للرسم البياني، ومنها تم تحديد القيمة القصوى للتيار والجهد كما تم تحديد جهد الدائرة المفتوحة وتيار الدائرة القصيرة. وبتطبيق معادلات الخلية الشمسية تم حساب قيمة القدرة القصوى ومن ثم حساب الكفاءة. كررت نفس الخطوات بعد تطبيق الزيوت كل واحد على حدة. أظهرت النتائج التي تم الحصول عليها بعد تطبيق الزيوت انخفاضا في كفاءة اللوحة باستثناء نتائج زيت جنين القمح حيث أظهرت زيادة في كفاءة اللوحة مقارنة بنتائج اللوحة قبل تطبيق الزيوت عليها.

Table of Contents

No	Title	Page
	الآية	I
	Acknowledgements	II
	Abstract	III
	المستخلص	IV
	Table of Contents	V
	Table of Figures	VII
	Table of Tables	VIII
Chapter One Introduction		
1.1	Overview	1
1.2	Objective	1
1.3	Problem Statement	1
1.4	Literature Review	2
1.5	Dissertation Layout	2
Chapter two Renewable Energy		
2.1	Renewable Energy	3
2.2	Types of Renewable Energy	3
2.3	Advantages of Renewable Energy	4
2.4	Disadvantages of Renewable Energy	5
2.5	The Future of Renewable Energy	5
Chapter Three Solar Energy		
3.1	Introduction	6
3.2	Solar Radiation	6

3.3	Photovoltaic Energy	8
3.4	PV Cells	8
3.5	PV Cells Types	10
3.6	Solar Cells Equations	12
3.7	Solar Cells Characterization	14
3.8	PV Cells Applications	15
Chapter Four Results and Discussion		
4.1	Introduction	17
4.2	Instruments	17
4.3	Materials	19
4.4	Theories	19
4.5	Results	19
4.6	Discussion	24
Chapter Five Conclusion and Recommendations		
5.1	Conclusion	26
5.2	Recommendations	26
	References	

Table of Figures

No	Title	page
3.1	Solar radiation	6
3.2	Direct, diffuse and total solar radiation	7
3.3	Equivalent circuit for solar cell	9
3.4	The photovoltaic effect	10
3.5	Monocrystalline silicon cell	11
3.6	Polycrystalline silicon cell	12
3.7	Thin film cell	12
3.8	IV Curve of solar cells	15
4.1	Ammeter	17
4.2	Voltmeter	18
4.3	Artificial sun	18
4.4	Solar cell	18
4.5	Background	21
4.6	Sesame oil	22
4.7	Wheat germ oil	23
4.8	Bitter almond oil	24

Table of Tables

No	Title	Page
4.1	Background	21
4.2	Sesame oil	22
4.3	Wheat germ oil	23
4.4	Almond oil	24

Chapter one

Introduction

1.1 Overview

Energy is defined as the capacity to do work; it has been centuries since people used energy from burning coal to the invention of electricity [1].

There are different types of energy and they can be categorized into two broad categories, kinetic energy (the energy of moving objects) and potential energy (energy that is stored). These are the two basic forms of energy. The different types of energy include thermal energy, radiant energy, chemical energy, nuclear energy, electrical energy, motion energy, sound energy, elastic energy and gravitational energy [2]. Some energy sources are endless and cannot run out like the sun, wind and water etc. These sources are called renewable sources [3]. And the sources that can be run out are called nonrenewable energy sources like fossil fuel such as coal, gas and oils which can be used for industrial and house hold purposes. Without an alternative source of energy, we could soon be facing a major energy crisis and a disaster for our planet's health [2].

1.2 Objective

- To experience the effect of oils on the efficiency of solar panels.

1.3 Problem Statement

Although there are many methods to enhance the performance of solar cells, some of them are expensive and not affordable. In this research different types of commercial oils were used.

1.4 Literature Review

Some researchers tried to improve the efficiency of solar panels using coconut oil as a spectrum filter to decrease the temperature effect on the panels which reduce the efficiency [4].

In other research, the front layer of the cell was coated with a fine layer of oil in order to increase the amount of light transmitted to the cell and consequently its efficiency [5].

1.5 Dissertation Layout

This research consists of five chapters. Chapter one represents an overview about energy, objectives of the research and the problems statement. Information about renewable energy is provided in chapter two. Chapter three represents the concept of solar energy and solar cells. Chapter four focused on the instruments and materials used in the experiment, the experimental setup, discussion of the results and finally the conclusion. Recommendation and references are provided in chapter five.

Chapter Two

Renewable Energy

2.1 Renewable Energy

Due to a growing world population and increasing modernization, global energy demand is projected to more than double during the first half of the twenty-first century and to more than triple by the end of the century. Future energy demands can only be met by introducing an increasing percentage of alternative fuels. Incremental improvements in existing energy networks will be inadequate to meet this growing energy demand. Due to dwindling reserves and ever-growing concerns over the impact of burning carbon fuels on global climate change, fossil fuel sources cannot be exploited as in the past [5].

Renewable energy is obtained from natural sources. These resources can be used to produce energy again and again e.g. Solar energy, wind energy, tidal energy etc.

2.2 Types of Renewable Energy

- Tidal energy: Tidal energy is a form of hydropower that converts energy obtained from tides into useful forms of power, such as electricity. Tides are created by the gravitational effect of the moon and the sun on the earth causing cyclical movement of the seas. One of the strengths of harnessing power from tidal ranges and tidal streams over other forms of renewable energy is that the process is entirely predictable. [6]
- Wind energy: Wind is used to produce electricity using the kinetic energy created by air in motion. This is transformed into electrical energy using wind turbines or wind energy conversion systems. Wind first hits a

turbine's blades, causing them to rotate and turn the turbine connected to them. That changes the kinetic energy to rotational energy, by moving a shaft which is connected to a generator, and thereby producing electrical energy through electromagnetism [7].

- Geothermal energy: Geothermal energy has been used for thousands of years in some countries for cooking and heating. It is simply power derived from the Earth's internal heat. This thermal energy is contained in the rock and fluids beneath Earth's crust. It can be found from shallow ground to several miles below the surface, and even farther down to the extremely hot molten rock called magma [8].
- Wave energy: Waves form as wind blows over the surface of open water in oceans and lakes. Ocean waves contain tremendous energy [9].
- Solar energy: Solar power is energy from the sun that is converted into thermal or electrical energy. Solar energy is the cleanest and most abundant renewable energy source available. Solar technologies can harness this energy for a variety of uses, including generating electricity, providing light or a comfortable interior environment, and heating water for domestic, commercial, or industrial use [10].

2.3 Advantages of Renewable Energy

The advantages of renewable energy are that it is sustainable, available (found all over the world, as opposed to fossil fuels and minerals) and essentially non-polluting. Note that wind turbines and photovoltaic panels do not need water for electricity generation, as opposed to fossil fuel and nuclear power steam plants [11].

2.4 Disadvantages of Renewable Energy

The drawbacks of renewable energy are instability and low density, resulting in higher initial costs in general. Other disadvantages or perceived problems for different forms of renewable energy include visual pollution, odor from biomass, avian and bat mortality from wind turbines, and brine from geothermal energy [11].

2.5 The Future of Renewable Energy

As the world's population increases, so does the demand for energy to power our homes, businesses and communities. Innovation and the growth of renewable energy sources are crucial to sustaining sustainable energy levels and preserving our world against climate change. Renewable energy sources make up 26% of the world's electricity today, but according to the International Energy Agency (IEA) its share is expected to reach 30% by 2024. In the future, it's expected that the number of renewable energy sources will continue to increase as we see an increase in demand for power [3].

Chapter Three

Solar Energy

3.1 Introduction

The source of solar energy is the nuclear interactions at the core of the sun, where the energy comes from the conversion of hydrogen nuclei into helium nuclei. This energy is primarily transmitted to the Earth by electromagnetic waves, which can also be represented by particles (photons) [11].

3.2 Solar Radiation

The earth receives the solar energy in the form of solar radiation. The amount of solar radiation that reaches any given location is dependent on several factors like geographic location, time of day, season, land scope and local weather. Because the earth is round, the sun rays strike the earth surface at different angles (ranging from 0° to 90°). When sun rays are vertical, the earth's surface gets maximum possible energy.

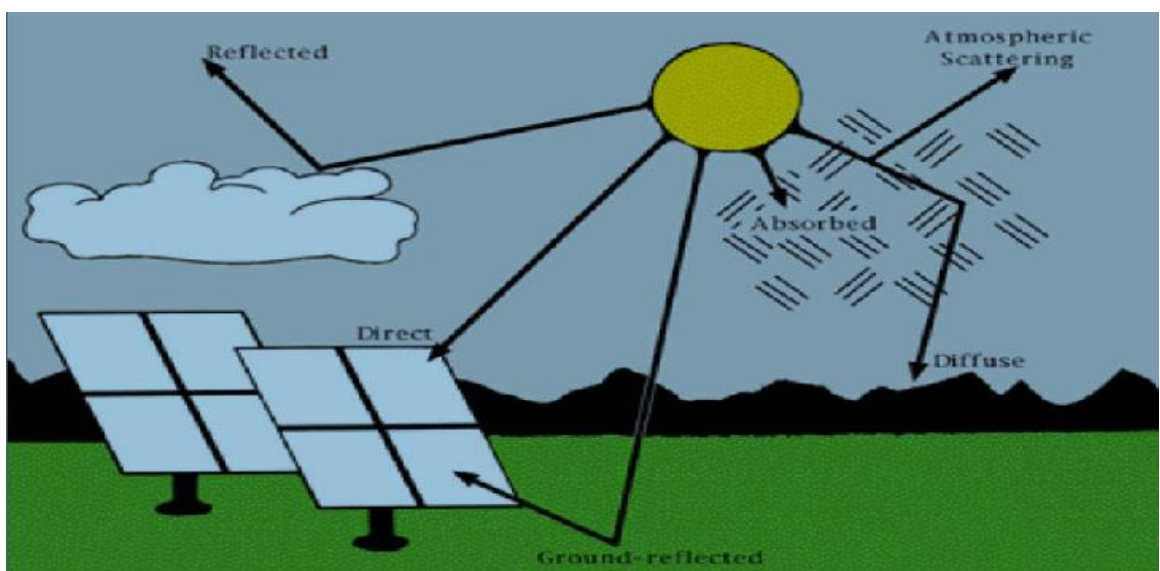

Figure 3.1: Solar radiation

The solar radiation that reaches the surface of the earth without being diffused is called direct beam solar radiation. It is measured by instrument named as pyrhelimeter.

As sun light passes through the atmosphere, some part of it is absorbed, scattered and reflected by air molecule, water vapours, clouds, dust and pollutants. This is called diffuse solar radiation. The diffuse solar radiation does not have unique path.

The sum of the direct and diffuse solar radiations is called total radiation or global solar radiation.

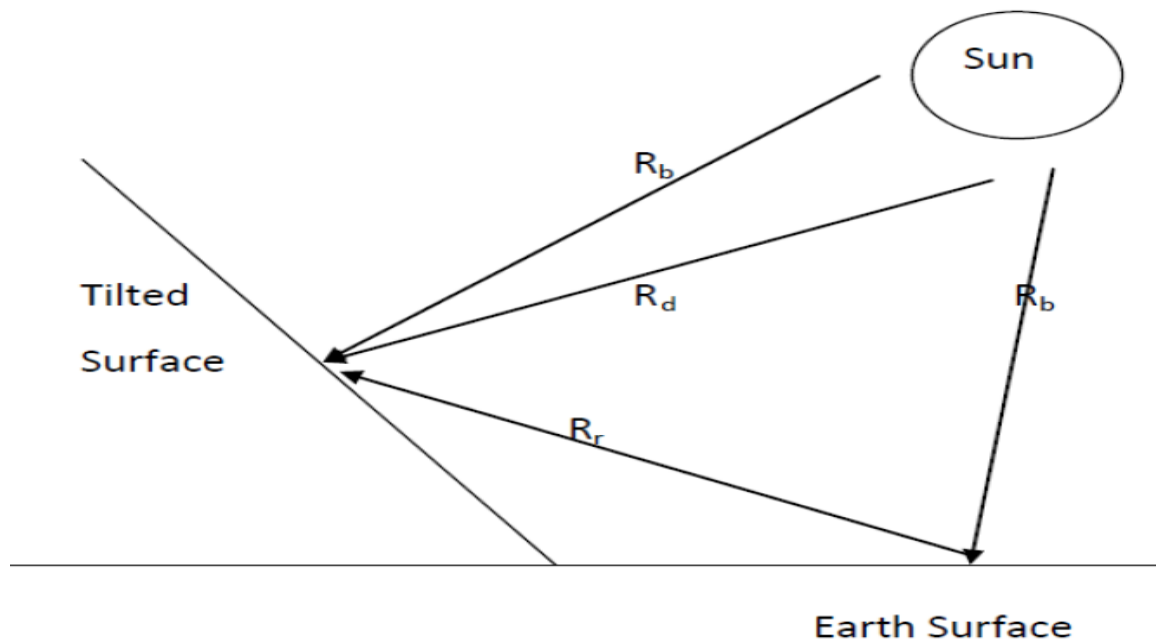

Figure 3.2: Direct, diffuse and total solar radiation

If,

R_b - Beam Radiation (direct solar radiation)

R_d - Diffuse Radiation (solar radiation after diffusion)

R_r - Reflected radiation (solar radiation after reflection from surface)

R_t - Total solar radiation on tilted surface

Then,

$$R_t = R_b + R_d + R_r \quad (3.1)$$

3.3 Photovoltaic Energy

The term “photovoltaic” derives from the Greek (phos) meaning “light”, and “voltaic”, meaning electric, to honor the name of the Italian physicist Volta after whom the volt is named. The photovoltaic effect was first discovered in 1839 by French physicist A.E. Becquerel. In 1883 Charles Fritts coated selenium with an extremely thin layer of gold, thus creating a PV device which was only around 1% efficient. Russel Ohl patented the modern junction semiconductor solar cell in 1946, which was discovered while working on the series of advances that would eventually lead to the development of the transistor. In 1954, workers at Bell Laboratories accidentally found that silicon doped with certain impurities was very sensitive to light, and Daryl Chapin, along with Bell Labs colleagues Calvin Fuller and Gerald Pearson, invented the first practical device for converting sunlight into useful electrical power, with a sunlight energy conversion efficiency of around 6% [13].

3.4 PV Cells

An energy harvesting technology, that converts solar energy into useful electricity through a process called the photovoltaic effect. There are several different types of PV cells which all use semiconductors to interact with incoming photons from the Sun in order to generate an electric current.

A photovoltaic cell is a p-n semiconductor junction. As light falls on solar panel, a (dc) current is generated. The equivalent circuit is shown in Fig3.3 [14].

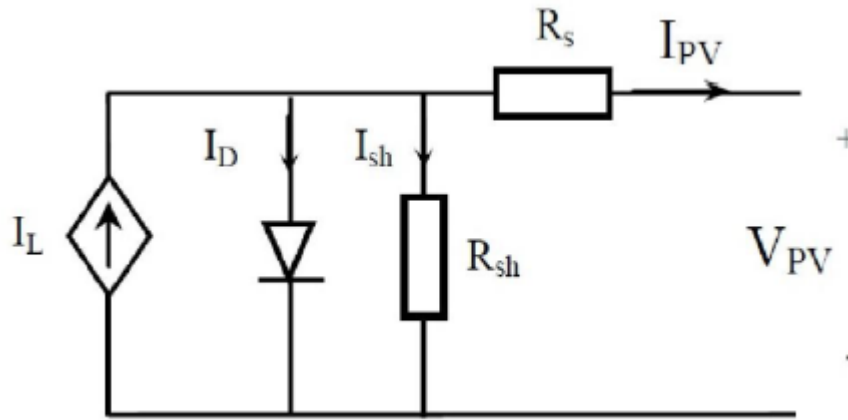

Figure 3.3: equivalent circuit of PV cell

Where

V_{PV} = PV module voltage (V).

I_{PV} = PV module current (A).

R_s = series resistance (Ω).

R_{sh} = shunt resistance (Ω).

I_L = load current (A).

A photovoltaic cell is comprised of many layers of materials, each with a specific purpose. The most important layer of a photovoltaic cell is the specially treated semiconductor layer. It is comprised of two distinct layers (p-type and n-type—see Figure 3.4), and is what actually converts the Sun's energy into useful electricity through the photovoltaic effect. On either side of the semiconductor is a layer of conducting material which "collects" the electricity produced. Note that the backside or shaded side of the cell can afford to be completely covered in the conductor, whereas the front or illuminated side must use the conductors sparingly to avoid blocking too much of the Sun's radiation from reaching the semiconductor. The final layer which is applied only to the illuminated side of the cell is the anti-reflection coating. Since all semiconductors are naturally reflective, reflection loss can be significant. The solution is to use one or several layers of an anti-reflection coating (similar to those used for eyeglasses and cameras) to reduce the amount of solar radiation that is reflected off the surface of the cell [15].

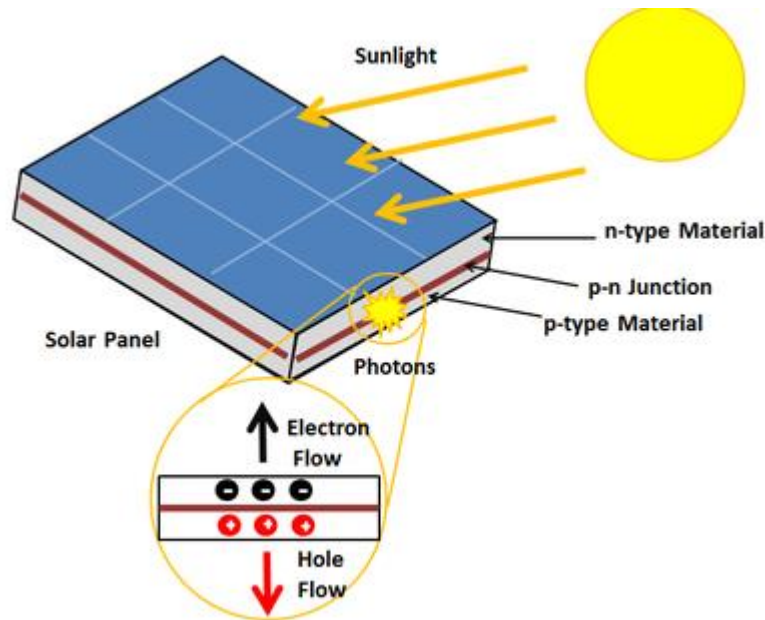

Figure 3.4: the photovoltaic effect

3.5 PV Cells Types

PV cells can be manufactured in many different ways and from a variety of different materials. Despite this difference, they all perform the same task of harvesting solar energy and converting it to useful electricity. The most common material for solar panel construction is silicon which has semiconducting properties. Several of these solar cells are required to construct a solar panel and many panels make up a photovoltaic.

- **Monocrystalline Silicon Cell**

The first commercially available solar cells were made from monocrystalline silicon, which is an extremely pure form of silicon. To produce these, a seed crystal is pulled out of a mass of molten silicon creating a cylindrical ingot with a single, continuous, crystal lattice structure. This crystal is then mechanically sawn into thin wafers, polished and doped to create the required p-n junction. After an anti-reflective coating and the front and rear metal contacts are added, the cell is finally wired and packaged alongside many other cells into a full solar panel. Monocrystalline silicon cells are highly efficient, but their manufacturing process is slow and labour intensive, making them more expensive [15].



Figure 3.5: Monocrystalline silicon cell

- **Polycrystalline Silicon Cell**

Polycrystalline silicon (also called: polysilicon, poly crystal, poly-Si or also: multi-Si, mc-Si) are manufactured from cast square ingots, produced by cooling and solidifying molten silicon. The liquid silicon is poured into blocks which are cut into thin plates. The solidification of the material results into cells that contain many crystals, making the surface of the poly-Si/ mc-Si cell less perfect than its mono-Si counterpart. Due to these defects, polycrystalline cells absorb less solar energy, produce consequently less electricity and are thus less efficient than monocrystalline silicon (mono-Si) cells. Due to their slightly lower efficiency, poly-Si/ mc-Si cells are conventionally a bit larger, resulting in comparably larger PV modules, too. This factor has to be considered if space is limited. Nevertheless, the advantage of poly-Si/ mc-Si cells is that they are easier and thus cheaper to produce [16].

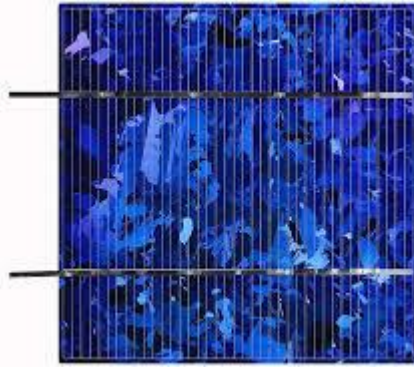

Figure 3.6: Polycrystalline silicon cell

- **Thin Film Cells**

Although crystalline PV cells dominate the market, cells can also be made from thin films—making them much more flexible and durable. One type of thin film PV cell is amorphous silicon (a-Si) which is produced by depositing thin layers of silicon on to a glass substrate. The result is a very thin and flexible cell which uses less than 1% of the silicon needed for a crystalline cell [15].



Figure 3.7: Thin film cell

3.6 Solar Cell Equations

In order to derive the ideal current-voltage characteristics of a p–n junction diode when illuminated by light, mathematical results from the ideal diode equation are

combined with the illuminated characteristics of the solar cell. The ideal diode law is expressed as the following equation:

$$I = I_0 \left(\exp \left(\frac{qV}{K_B T} \right) - 1 \right) \quad 3.2$$

Where I_0 the saturation current density, is given by

$$I_0 = A \left(\frac{q D_e n_i^2}{L_e N_A} + \frac{q D_h n_i^2}{L_h N_D} \right) \quad 3.3$$

Where

N_A = the acceptor concentration in the p-region.

N_D = the donor concentration in the n-region.

n_i = intrinsic carrier concentration.

D_h = diffusion coefficient of the holes.

D_e = diffusion coefficient of the electrons.

L_e = Diffusion length (how far into the material before electrons diffuse) of the electrons.

L_h = Diffusion length of the holes.

A = the cross-sectional area of the diode.

q = The magnitude of the electronic charge.

K_B = Boltzmann's constant.

$$I = I_0 \left(\exp \left(\frac{qV}{K_B T} \right) - 1 \right) - I_L \quad 3.4$$

I_L is related to the photon flux incident on the cell and is dependent on the wavelength of the incident light. The illuminated characteristics of the current are the same as the regular diode (or dark) characteristics, but shifted down by the current I_L . A majority carrier is the charge carrier that determines current. Majority carriers in a p-type material are holes and therefore its minority carriers are electrons. Majority carriers in an n-type material are electrons and its

minority carriers are holes. An intrinsic carrier is a semiconductor with valence band holes and conduction band electrons present in equal numbers.

3.7 Solar Cell Characterization

For the characterization of solar cell performance, three parameters are used: short circuit current (I_{sc}), open circuit voltage (V_{oc}), and fill factor (FF). In order to find open circuit voltage, I in Equation 3.4 is set to 0 (meaning short circuit current) to give the ideal value as follows:

$$V_{oc} = \frac{K_B T}{q} \ln \left(\frac{I_L}{I_0} + 1 \right) \quad 3.5$$

$$FF = \frac{V_{mp} I_{mp}}{V_{oc} I_{sc}} \quad 3.6$$

Where V_{mp} is the maximum voltage and I_{mp} is the maximum current.

The energy conversion efficiency for solar cells is calculated using the following equation:

$$\eta = \frac{V_{mp} I_{mp} FF}{P_{in}} \quad 3.7$$

Where P_{in} is the total power in the light incident on the cell. This equation demonstrates the dependency of efficiency calculations on the fill factor.

Figure 3.8 shows a graphical illustration of I_{sc} , V_{oc} , I_{mp} and V_{mp} and also illustrates the difference between light and dark current [5].

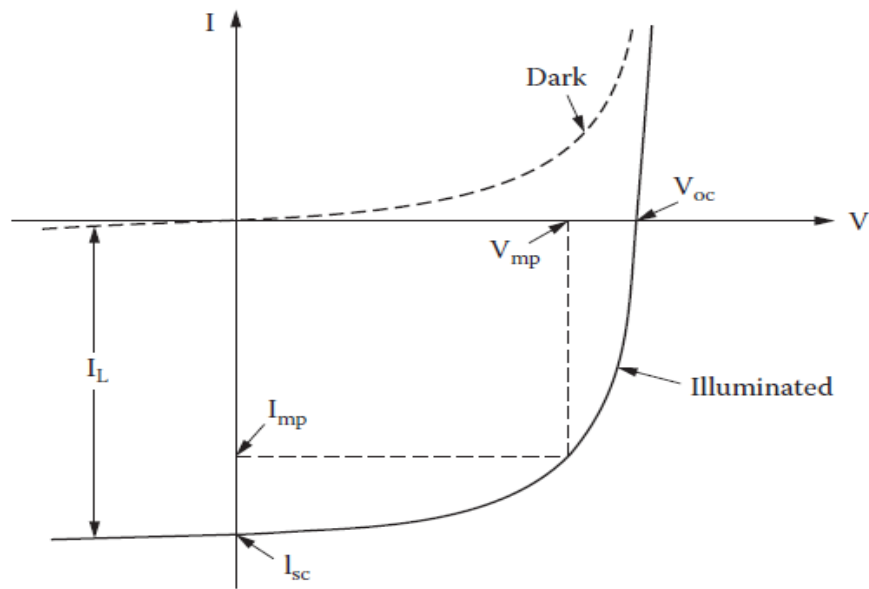

Figure 3.8: IV curve of solar cells.

3.8 PV Cells Applications

- **Solar Farms**

Many acres of PV panels can provide utility-scale power—from tens of megawatts to more than a Giga watt of electricity. These large systems, using fixed or sun-tracking panels, feed power into municipal or regional grids.

- **Stand-Alone Power**

In urban or remote areas, PV can power stand-alone devices, tools, and meters. PV can meet the need for electricity for parking meters, temporary traffic signs, emergency phones, radio transmitters, water irrigation pumps, stream-flow gauges, remote guard posts, lighting for roadways, and more.

- **Building-Related Needs**

In buildings, PV panels mounted on roofs or ground can supply electricity. PV material can also be integrated into a building's structure as windows, roof tiles, or cladding to serve a dual purpose. In addition, awnings and parking structures can be covered with PV to provide shading and power.

- **Military Uses**

Lightweight, flexible thin-film PV can serve applications in which portability or ruggedness is critical. Soldiers can carry lightweight PV for charging electronic equipment in the field or at remote bases [17].

Chapter Four

Calculations and Results

4.1 Introduction

In this chapter the experiment setup is represented, including the instruments, materials, and results of the performance of the solar cell before and after applying oils.

4.2 Instruments

- **Ammeter**

An ammeter is a measuring instrument used to measure the current in a circuit.



Figure 4.1: Ammeter

- **Voltmeter**

A voltmeter is an instrument used for measuring electric potential difference between two points in an electric circuit.



Figure 4.2: Voltmeter

- **Artificial Sun (Table Lamp)**



Figure 4.3: Artificial sun

- **Solar Cell**

A solar cell, or photovoltaic cell, is an electrical device that converts the energy of light directly into electricity by the photovoltaic effect.



Figure 4.4: solar cell

4.3 Materials

- Sesame oil: is an edible vegetable oil derived from sesame seeds (density at 25 C is 0.9140-0.9190).
- Wheat germ oil: Wheat germ oil is extracted from the germ of the wheat kernel.(density at 25 C is 0.9250-0.9330)
- Bitter almond oil. Extracted from almond tree seeds (density at 25 C is 1.4640-1.4700). [18]

4.4 Theories

$$P_{max} = I_{max} \times V_{max} \quad 4.1$$

P_{max} , I_{max} and V_{max} represent maximum power, current and voltage, respectively.

$$FF = \frac{P_{max}}{I_{sc} \times V_{oc}} \quad 4.2$$

Where FF , I_{sc} and V_{oc} represent the fill factor, short circuit current, open circuit voltage, respectively.

$$\eta = \frac{FF}{I.A} \quad 4.3$$

η Represents the efficiency of the solar cell, A represents area (and I is the intensity of radiation ($I = 1.3 \text{ W/m}^2$)).

4.5 Results

The characteristics readings of the solar panel were recorded to give the results as follows:

- **Background**

From figure 4.5 and Eq. (4.1, 4.2, 4.3)

$$P_{max} = 3.735 \times 33 \times 10^{-3} = 123 \times 10^{-3} W$$

$$FF = \frac{123 \times 10^{-3}}{44 \times 10^{-3} \times 3.895} = 0.71$$

$$\eta = \frac{0.71}{1.3 \times 1} = 0.54$$

- **Sesame Oil**

From figure 4.6 and Eq. (4.1, 4.2, 4.3)

$$P_{max} = 4.145 \times 33 \times 10^{-3} = 136 \times 10^{-3} W$$

$$FF = \frac{136 \times 10^{-3}}{4.25 \times 10^{-3} \times 46} = 0.699$$

$$\eta = \frac{0.699}{1.3 \times 1} = 0.53$$

- **Wheat Germ Oil**

From figure 4.7 and Eq. (4.1, 4.2, 4.3)

$$P_{max} = 4.118 \times 37 \times 10^{-3} = 152 \times 10^{-3} W$$

$$FF = \frac{152 \times 10^{-3}}{4.24 \times 10^{-3} \times 46} = 0.78$$

$$\eta = \frac{0.78}{1.3 \times 1} = 0.60$$

- **Bitter Almond Oil**

From figure 4.8 and Eq. (4.1, 4.2, 4.3)

$$P_{max} = 4.136 \times 33 \times 10^{-3} = 136 \times 10^{-3} W$$

$$FF = \frac{136 \times 10^{-3}}{4.23 \times 10^{-3} \times 46} = 0.70$$

$$\eta = \frac{0.70}{1.3 \times 1} = 0.53$$

Table 4.1 and Figure 4.5 show the background performance of the cell

Table 4.1: background results

V/Volt	I/mA	V/Volt	I/mA
3.89	12	3.77	28
3.88	14	3.75	30
3.86	16	3.74	32
3.85	18	3.72	34
3.83	20	3.69	36
3.82	22	3.67	38
3.8	24	3.64	40
3.78	26	3.62	42

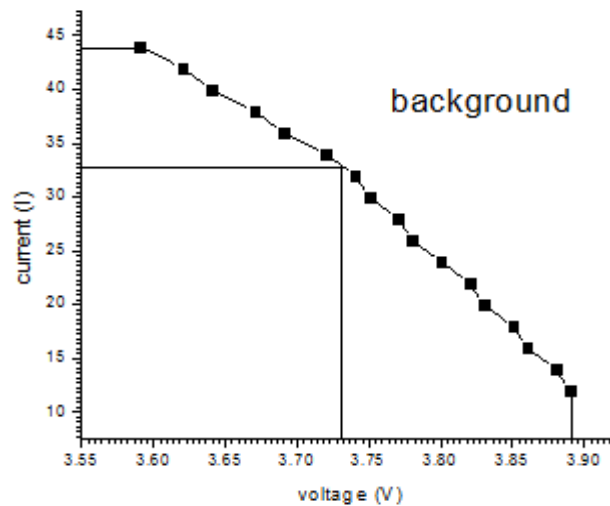

Figure 4.5: background

Table 4.2 and Figure 4.6 show the performance of the solar cell coated with sesame oil.

Table 4.2: sesame oil

V/Volt	I/mA	V/Volt	I/mA
4.25	14	4.16	30
4.24	16	4.15	32
4.23	18	4.13	34
4.22	20	4.12	36
4.2	22	4.11	38
4.19	24	4.1	40
4.19	26	4.09	42
4.17	28	4.08	44

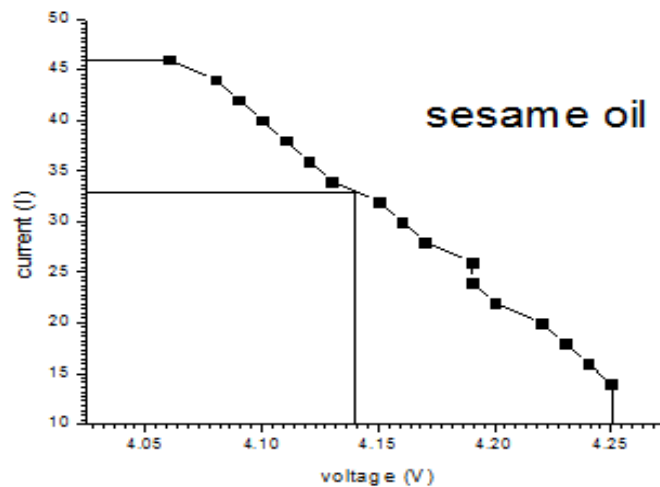

Figure 4.6: sesame oil

Table 4.3 and Figure 4.7 show the performance of the solar cell coated with wheat germ oil

Table 4.3: wheat germ oil

V/Volt	I/mA	V/Volt	I/mA
4.24	14	4.16	30
4.24	16	4.15	32
4.23	18	4.14	34
4.21	20	4.13	36
4.2	22	4.11	38
4.19	24	4.1	40
4.18	26	4.08	42
4.17	28	4.07	44

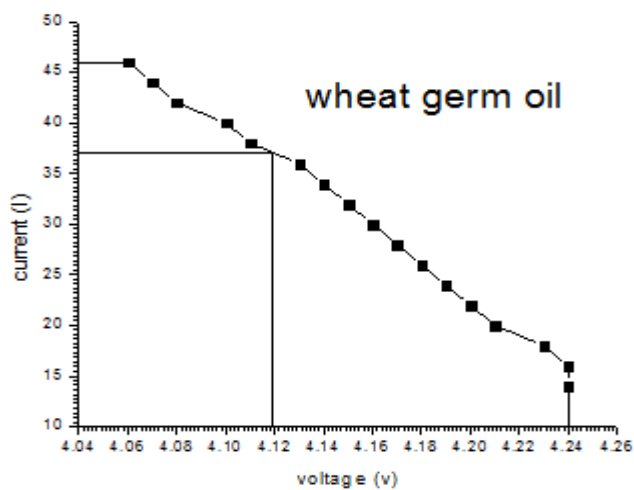

Figure 4.7: wheat germ oil

Table 4.4 and Figure 4.8 show the performance of the panel coated with bitter almond oil

Table 4.4: bitter almond oil

V/Volt	I/mA	V/Volt	I/mA
4.23	14	4.15	30
4.22	16	4.14	32
4.21	18	4.13	34
4.2	20	4.11	36
4.19	22	4.1	38
4.18	24	4.09	40
4.17	26	4.07	42
4.16	28	4.06	44

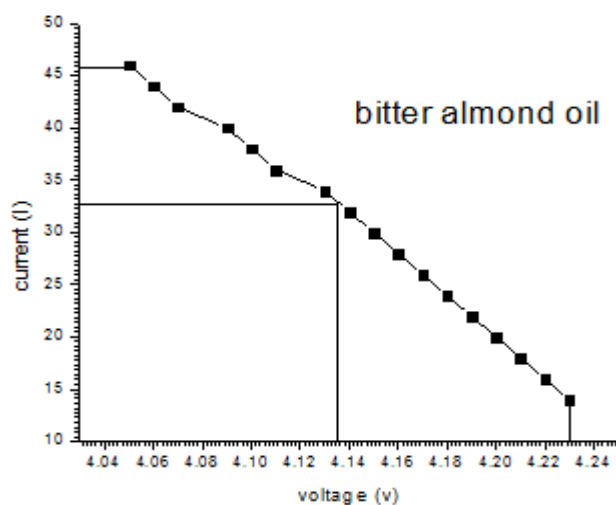

Figure 4.8: bitter almond oil

4.6 Discussion

The experiment aims to study the effect of natural oils (sesame oil, wheat germ oil, and bitter almond oil.) on the efficiency of the solar cell and to compare the results to the background efficiency. The cell was coated with a thin layer of oil; the current and voltage results were recorded in tables and plotted in graphs

using Origin graphing program. From the figures, the maximum current and voltage, the short circuit current and the open circuit voltage were recorded in order to calculate the efficiency using the solar cell equations. Coating the cell with sesame oil reduced the efficiency from 54% to 53%, the exact results for almond oil. The only oil that enhanced the performance of the panel was wheat germ oil, the efficiency increased from 54% to 60%.

Chapter Five

Conclusion and Recommendations

5.1 Conclusion

In this study, a solar panel was coated with oils to study the impact of the oils on the efficiency. Three types of commercial natural oils were examined (sesame oil, wheat germ oil and bitter almond oil.) after applying sesame oil the voltage results fell and also the same thing for almond oil, this caused a reduction in the efficiency of the panel, except for wheat germ oil, the efficiency increased. Comparing the results of the panel before and after coating, wheat germ oil results gave the highest efficiency ($\eta=0.60$) and the performance of the panel after applying the two other oils showed a reduction in the efficiency ($\eta=0.53$ using bitter almond oil, and $\eta=0.53$ using sesame oil).

5.2 Recommendation

For future studies the following is suggested:

- Use pure oils with experimentally measured properties.
- After applying oils, try to avoid dust formation which reduces the efficiency.
- Use a cooling system to avoid the effect of high temperatures.

References

- [1] Saurabh Kumar Rajput, *SOLAR ENERGY- Fundamentals, Economic and Energy Analysis*. Rajnagar, Ghaziabad, india: Northern India Textile Research Association, 2017.
- [2] solar schools. [Online]. <https://www.solarschools.net>.
- [3] eDF. [Online]. <https://www.edfenergy.com>.
- [4] S.G.Keerthika T.Sabapathi, "design a photovoltaic system with an improved efficiency using suitable optical designs," *International Journal of Applied Engineering Research*, vol. 14.
- [5] Majid Ghassemi, Alma Cota Robert Foster, *solar energy:renewable energy and the enviroment.:* Taylor & Francis Group, 2010.
- [6] intertek. [Online]. <https://www.intertek.com>.
- [7] (2011) International Renewable Energy Agency. [Online]. <https://www.irena.org/>.
- [8] nationa geographic. [Online]. <https://www.nationalgeographic.com>.
- [9] eia. [Online]. <https://www.eia.gov>.
- [10] SEIA. [Online]. <https://www.seia.org>.
- [11] Vaughn Nelson, *introduction to renewable energy.:* Taylor & Francis Group, 2011.
- [12] Saurabh Kumar Rajput, *SOLAR ENERGY- Fundamentals, Economic and Energy Analysis First Edition.*, 2017.
- [13] CHRISTOPHER J. RHODES, "Solar energy: principles and," vol. 93, 2010.
- [14] Mulani Saifali Abbas, Shinde Mayur Balasaheb ,Chaure Balaji Mohan Shaikh Mohamadsaied Rubab, "A Review Paper on Improving The Efficiency Of Solar Panel," vol. 04, no. 10, 2017.

- [15] Jordan Hanania, Kailyn Stenhouse, Jason Donev Bethel Afwork. (2018) energy education. [Online]. <https://energyeducation.ca>.
- [16] sinovoltaics. [Online]. <https://sinovoltaics.com/>.
- [17] NREL Transforming Energy. [Online]. <https://www.nrel.gov/>.
- [18] action renewables. [Online]. <https://actionrenewables.co.uk/>.