

الإستهلال



## الآية

قال الله عز وجل :

((وَيَسْأَلُونَكَ عَنِ الرُّوحِ ۖ قُلِ الرُّوحُ مِنْ أَمْرِ رَبِّي وَمَا أُوتِيتُمْ مِنَ الْعِلْمِ إِلَّا قَلِيلًا))



[ سورة الإسراء : 85 ]

# DEDICATION

To our beloved mothers and fathers who supported us,  
To our brothers and sisters,  
To our friends and study partners  
To everyone who make a positive effect on us.

## ACKNOWLEDGEMENTS

In the Name of Allah, the most merciful, the most compassionate  
praise Be to Allah, the lord of the worlds; the prayers and peace be upon  
Mohamed hid servant and messenger.

First, thanks to God who lights our ways and our minds. And then  
many thanks to our supervisor **A. Musab Mohammed Salih** who  
has guided us and direct us for the duration of the search.

We would like to thank **Dr.Khalifa Altaieb** for his support.

We would like to express our sincere thanks to **Dr.Azza Kamal**.

We would like to **A. Esraa Nasreldeen Abozaid Satti** thank for  
her support

**And all those who contributed to the success of this work.**

## **ABSTRACT**

Agriculture is considered one of the most important economic activities in the world and it has acquired a large share of technology in our time. In this research, a built-in system is designed to monitor and control certain environmental indicators such as temperature, relative humidity, soil moisture and lighting intensity in a greenhouse. Internet of things technology is used to enable the user to manage the greenhouse at anytime and anywhere in the world. This system consists of sensors, micro-controllers, and a wireless intermediary, a display screen to display the results, and devices to adjust the environmental conditions inside the greenhouse such as a fan, electric heater and water pump. This system is highly flexible and tolerant with faults. It is provided with a procedure to manage it in order to maintain the required climatic conditions in the greenhouse, and it is also provide with the ability to control it via the Internet in the event of an error in the automatic control. The extracted results confirmed the effectiveness of used wireless sensor networks technology and Internet of things technology in the management of the greenhouse and the possibility of linking a number of greenhouses together.

## المستخلص

تعتبر الزراعة واحدة من أهم الأنشطة الاقتصادية في العالم وقد نالت نصيباً وافراً من التكنولوجيا في وقتنا الحالي. في هذا البحث تم تصميم نظام مدمج للمراقبة والتحكم في المؤشرات البيئية المعينة كالحرارة والرطوبة النسبية ورطوبة التربة وشدة الإضاءة في البيت المحمي يقوم هذا التصميم علي شبكات الاتصال اللاسلكية علي أساس منتظم علي الساعة لتوفير بيئة مناسبة لزراعة النباتات المطلوبة, و أيضاً تم تضمين تكنولوجيا انترنت الأشياء ليتمكن المستخدم من ادارة البيت المحمي في اي وقت و اي مكان في العالم . يتكون هذا النظام من اجهزة الاستشعار و المتحكمات الدقيقة و وسيط لاسلكي و شاشة عرض لعرض النتائج و اجهزة لضبط الظروف البيئية داخل البيت المحمي مثل المروحة و السخان الكهربائي و مضخة الماء . هذا النظام عالي المرونة و السماحية مع الاعطال تم تزويده بإجرائية لإدارته من اجل المحافظة علي الظروف المناخية المطلوبة في البيت المحمي , كما تم تزويده بإمكانية التحكم فيه عبر الانترنت في حالة حدوث خطأ في التحكم التلقائي . النتائج المستخلصة أكدت علي فاعلية استخدام تقنية شبكات الاستشعار اللاسلكية و تقنية انترنت الأشياء في إدارة البيت المحمي و إمكانية ربط عدد من البيوت المحمية مع بعضها .

## Table of Contents

الإستهلال .....	I
الآية .....	II
<b>DEDICATION</b> .....	<b>III</b>
<b>ACKNOWLEDGEMENTS</b> .....	<b>IV</b>
<b>ABSTRACT</b> .....	<b>V</b>
المستخلص .....	VI
<b>LIST OF TABLES</b> .....	<b>X</b>
<b>LIST OF FIGURES</b> .....	<b>XI</b>
<b>LIST OF ABBREVIATIONS</b> .....	<b>XIII</b>
<b>LIST OF SYMBOLS</b> .....	<b>XV</b>
<b>Chapter One: Introduction</b> .....	<b>2</b>
1.1 Preface .....	2
1.2 Problem statement.....	3
1.3 Proposed solution .....	3
1.4 Objectives.....	3
1.5 Methodology .....	3
1.6 Research Outline .....	4
<b>Chapter Two: Literature Review</b> .....	<b>8</b>
2.1 Introduction .....	8
2.1.1 Effect of environmental factors.....	8
2.2 Sensors .....	11
2.3 Internet of Things.....	12
2.3.1 IoT benefits.....	14

2.3.2 Applications.....	15
2.4 Wireless Sensor Network in Greenhouse .....	17
2.4.1 Characteristics of WSN .....	18
2.4.2 Applications of WSN .....	18
2.5 Microcontrollers .....	19
2.5.1 Arduino.....	20
2.6 Related works .....	24
<b>Chapter Three: Methodology .....</b>	<b>30</b>
3.1 System Block Diagram .....	30
3.2 Sensing Unit .....	30
3.2.1 DHT11 Humidity & Temperature Sensor.....	31
3.2.2 Ultrasonic sensor .....	33
3.2.3 Soil moisture.....	36
3.2.4 Light Dependent Resistor.....	37
3.3 Processing Unit .....	39
3.3.1 Arduino Uno:.....	39
3.3 Wireless communication unit .....	40
3.3.1 nRF24L01 .....	41
3.4 Display Unit .....	46
3.5 Controlling Unit .....	47
3.5.1:ESP8266 .....	47
3.6 Actuation System .....	50
3.7 Power Supply .....	51
3.8 The Flow Chart .....	52
<b>Chapter Four: Result and Discussion .....</b>	<b>55</b>
4.1 Introduction .....	55
4.1.1 Monitoring unit: .....	55



4.1.2 Control Unit.....	56
<b>Chapter Five: Conclusion and Recommendations .....</b>	<b>65</b>
5.1 Conclusion.....	65
5.2 Recommendations .....	65
<b>REFERENCES .....</b>	<b>66</b>

## LIST OF TABLES

<b>TABLE NO</b>	<b>TITLE</b>	<b>PAGE</b>
3.1	Technical Specification of DHT11	28
3.2	Technical Specification of LDR	33
3.3	nRF24L01 pin function	37
3.4	Technical Specifications of the LCD	39

## LIST OF FIGURES

<b>FIGURE</b>	<b>TITLE</b>	<b>PAGE</b>
2.1	IoT network architecture	13
2.2	A block diagram of a microcontroller	19
2.3	Arduino Uno	21
2.4	Arduino Mega	22
2.5	Arduino LilyPad	23
2.6	Arduino Nano	23
3.1	Block diagram of greenhouse management system	30
3.2	DHT11 Sensor	31
3.3	Typical Application	32
3.4	Overall Communication Process	33
3.5	Ultrasonic sensor	34
3.6	Timing Diagram of Ultrasonic sensor	35
3.7	Soil moisture sensor	36
3.8	Appearance structure of soil moisture sensor	37
3.9	Light Dependent Resistor	38
3.10	The Circuit of LDR	39
3.11	Arduino Uno	40
3.12	nRF24L01 block diagram	43
3.13	nRF24L01 pin assignment (top view) for a QFN20 4x4 package	44
3.14	nRF24L01 in a star network configuration	45
3.15	LCD and Its Pin Out	46
3.16	ESP8266 Block Diagram	48
3.17	Design of Power Supply	51
4.1	Monitoring Unit	55
4.2	Control Unit	56
4.3	The Decreasing Temperature	58
4.4	The Increasing Temperature	58
4.5	The Decreasing Humidity	59
4.6	The Increasing Humidity	59
4.7	The Increasing Light	60
4.8	The Decreasing Light	60
4.9	The Increasing water	61
4.10	The Decreasing water	61
4.11	The Increasing level of water	62
4.12	The Decreasing level of the Water	62

4.13	Website Page	63
------	--------------	----

## LIST OF ABBREVIATIONS

Abbreviation	Explanation
AC	Alternate current
AI	Artificial Intelligence
AVR	Advanced Virtual Risk
CPU	Central Processing Unit
DC	Direct Current
DHT	Digital Humidity and Temperature
EEPROM	Electrical Erasable Programmable Read Only Memory
ESCP	Espressif Systems' Smart Connectivity Platform
FIFO	First In First Out
GFSK	Gaussian Frequency Shift Keying
GND	Ground
GSM	Global System Mobile
ICSP	In-Circuit Serial Programming
IOT	Internet of Things
IT	Information Technology
LCD	Liquid Crystal Display
LCD	Liquid Crystal Display
LDR	Light Dependent Resistor
MCU	Micro-computer Unite
MEMS	Micro Electro Mechanical System
PID	Proportional Integral and Derivative
PSRR	Power Supply Rejection Ratio
PWM	Pulse Width Modulation
QFN	Quad Flat No-lead
RF	Radio Frequency
RX	Receiver
SPI	Serial Peripheral Interface
SRAM	Static random-access Memory
TX	Transmit
USB	Universal Serial Bus

WSAN	Wireless Sensor Actor Network
WSN	Wireless Sensor Network

## LIST OF SYMBOLS

MHz	Mega Hertz
KB	Kilo Byte
A	Ampere
°C	Degree Celsius
GHz	Gaga Hertz
V	Voltage
W	Watt

# **CHAPTER ONE**

## **INTRODUCTION**



# **CHAPTER ONE**

## **INTRODUCTION**

**1.1 Preface**

**1.2 Problem Statement**

**1.3 Proposed solution**

**1.4 Objectives**

**1.5 Methodology**

**1.6 Research Outline**

# Chapter One: Introduction

## 1.1 Preface

A greenhouse is a building where plants are grown. Greenhouse protects crops from too much heat or cold, shield plants from dust storms and blizzards, and help to keep out pests. Light and temperature control allows greenhouse to turn land unsuitable for cultivation into arable land, thereby improving food production in marginal environments. Greenhouses are increasingly important in the food supply of high latitude countries. The closed environment of the greenhouses has its own unique requirements, compared with outdoor production. Pests and diseases, and extremes of the heat and humidity, have to be controlled, and irrigation is necessary to provide water. Significant inputs of the heat and light may be required, particularly in the winter production of warm weather vegetables. Because the temperature and humidity of greenhouses must be constantly monitored to ensure optimal conditions, a WSN can be used to gather data remotely. The data are transmitted to a central location and used to control heating, cooling, and irrigation systems. [1]

A wireless sensor network (WSN) consists of spatially distributed autonomous sensors to monitor physically or environmental conditions, such as temperature, sound, vibration, pressure, motion or pollutants and to cooperatively pass their data through the network to a main location. WSN can be used in some special situation for signal collection, processing and transmitting. Wireless technologies have been rapidly developed during recent years. Its advantages include the liability, simplicity, and low cost in both installation and maintenance .[1]

## **1.2 Problem Statement**

Greenhouses are often used for growing flowers, vegetables, fruits, and tobacco plants. Most greenhouse systems still use the manual system in managing the temperature, humidity, water and light in the greenhouse, a lot of problems can occur not for worker but also affected production rate because the Temperature, Humidity, Water and Light of the greenhouse must be constantly managed to ensure optimal conditions. Greenhouse installations require a large amount of wires and cables to distribute sensors and actuators.

## **1.3 Proposed Solution**

Designing a management system for greenhouse based on (WSN) Wireless Sensor Network and (IOT) Internet of Things.

## **1.4 Objectives**

1. Design a system capable of providing a solution that changes with changing climatic conditions on four parameters: the level of soil moisture content, humidity, light intensity, water level and temperature.
2. Design a system that has ability to manage the environmental conditions wirelessly.
3. The user can see the conditions around the greenhouse plants on the website and can also manage the parameters of the greenhouse from remote locations [remote places]

## **1.5 Methodology**

The greenhouse management system consists of two units, the first is the Monitoring unit and the second unit is the control unit, where the Monitoring unit measures environmental information such as temperature, humidity, light intensity, and soil moisture; and sends environmental

information to the Control unit where the control unit receives environmental information and adjusts the conditions Environmental according to greenhouse requirements, using fan, heater, LED, and pump. The Monitoring unit sends the environmental information to the server; So that the user can control and monitor the environmental conditions. ESP8266 is selected to be the processing module for the Monitoring unit and Arduino Uno for the processing module for the Controlling unit . And the programming is done in C language. And communication between them is achieved via **nRF24L01** modules in each.

## **1.6 Research Outlines**

The research covers an abstract and five Chapters. Chapter One contains an introduction including the objective and general idea of the project. Chapter Two Highlights the literature review. Chapter Three explains in details the system design. Chapter Four Shows the simulation and circuit result of the system and its discussion. Chapter Five includes the conclusion and recommendations.

## **CHAPTER TWO**

### **LITERATURE REVIEW**

# **CHAPTER TWO**

## **LITERATURE REVIEW**

**2.1 Introduction**

**2.2 Sensors**

**2.3 Internet of Things**

**2.4 Wireless Sensor Network in Greenhouse**

**2.5 Microcontrollers**

**2.6 Related works**



# **Chapter Two: Literature Review**

## **2.1 Introduction**

Growing plants is both an art and a science. About 95% of plants, either food crops or cash crops are grown in open field. Since time immemorial, man has learnt how to grow plants under natural environmental conditions. In some of the temperate regions where the climatic conditions are extremely adverse and no crops can be grown, man has developed methods of growing some high value crop continuously by providing protection from the excessive cold, which is called as Greenhouse Technology. So, Greenhouse Technology is the technique of providing favorable environment condition to the plants. It is rather used to protect the plants from the adverse climatic conditions such as wind, cold, precipitation, excessive radiation, extreme temperature, insects and diseases. It is also of vital importance to create an ideal micro climate around the plants. This is possible by erecting a greenhouse / glass house, where the environmental conditions are so modified that one can grow any plant in any place at any time by providing suitable environmental conditions with minimum labour. Greenhouses are framed or inflated structures covered with transparent or translucent material large enough to grow crops under partial or fully controlled environmental conditions to get optimum growth and productivity[2].

### **2.1.1 Effect of environmental factors**

Basic factors affecting plant growth such as sunlight, water Content in soil, air humidity, temperature, CO<sub>2</sub> concentration. These physical factors are hard to control manually inside a greenhouse and there is a need for automated design arises.



### **i. Temperature effects**

One of the benefits of growing crops in a greenhouse is the ability to control all aspects of the production environment temperature is one of the most important factors to be monitored because it is directly related to the growth and development of plants. Different crop species have different optimum growing temperatures and these optimum temperatures can be different for the root and the shoot environment and for the different growth stages during the life of the crop. Since we are usually interested in rapid crop growth and development, we need to provide these optimum temperatures throughout the entire cropping cycle. If a greenhouse were like a residential or commercial building, controlling the temperature would be much easier since these buildings are insulated so that the impact of outside conditions is significantly reduced [3].

### **ii. Humidity effects**

Water vapour inside the greenhouse is one of the most significant variables affecting the crop growth. Humidity is important to plants because it partly controls the moisture loss from the plant. The leaves of plants have tiny pores, CO<sub>2</sub> enters the plants through these pores, and oxygen and water leave through them. Transpiration rates decrease proportionally to the amount of humidity in the air. This is because water diffuses from areas of higher concentration to areas of lower concentration[4] . Due to this phenomenon, plants growing in a dry room will most likely lose its moisture overtime. The damage can be even more severe when the difference in humidity is large. The humidity control is complex because if temperature changes then relative humidity changes inversely. Temperature and humidity are

controlled by the same actuators. The main priority is for temperature control because it is the primary factor in the crop growth. Based on the inside relative humidity value the temperature set-point can be adjusted to control the humidity within a determined range. Hence to control the required humidity is very complex task. For proper control of humidity internal air can be exchange with outside air by properly controlling ventilations of the greenhouse[5].

### iii. **Light effect**

All things need energy to grow, human and animals get energy from food. Plants, on the other hand, get energy from the sun light through a process called photosynthesis. This is how light affects the growth of a plant. Without light, a plant would not be able to produce the energy it needs to grow. Aside from its effect through photosynthesis, light influences the growth of individual organs or of the entire plant in less direct ways. The most striking effect can be seen between a plant grown in normal light and the same kind of plant grown in total darkness. The plant grown in the dark will have a tall and spindling stem, small leaves, and both leaves and stem, lacking chlorophyll, are pale yellow. Plants grown in shade instead of darkness show a different response. Moderate shading tends to reduce transpiration more than it does photosynthesis. Hence, shaded plants may be taller and have larger leaves because the water supply within the growing tissues is better. With heavier shading, photosynthesis is reduced to an ever greater degree and, weak plants result[4]

#### iv. **Water level in soil effects**

Soil water also affects the crop growth. Therefore, the monitor & control of soil condition has a specific interest, because good condition of a soil may produce the proper yield. The proper irrigations and fertilizations of the crops are varies as per the type, age, phase and climate. The pH value, moisture contains, electric conductivity and the temp of a soil are some key parameters. The pH values and other parameters will help to monitor the soil condition. The temperature and the moisture can be controlled by the irrigation techniques like drift and sprinkles system in a greenhouse. The temperature of the soil and the inside temperature of the greenhouse are interrelated parameters, which can be, control by proper setting of ventilation. Since the temperature control is depends on direct sun radiation and the screen material used, the proper set point can adjust to control soil temperature. The temperature set-point value depends on actual temperature of the inside and outside of the greenhouse[6] .

## **2.2 Sensors**

A sensor is a device that receives a stimulus and responds with an electrical signal. The purpose of sensor is respond to some kind of an input physical property (stimulus) and to convert it into an electrical signal that is compatible with electronic circuits. needs one or more transducers of energy before a direct sensor can be employed to generate an electrical an electrical output . All sensors can be classified into active and passive. An active sensor required external power for its operation which is called execution signal. That signal is modified by the sensors to produce the output signal, for example thermistor is temperature sensitive resistor. A passive sensor doesn't need any additional energy source and directly generates an electric signal in response to external stimulus. The examples

are thermocouple, photodiode, and piezoelectric sensor [7]. There are two types of sensors direct and complex.

### 2.2.1 Types of sensors

- i. **Tactile sensors:** (touch sensors, force sensors, color sensor, tactile array sensors).
- ii. **Proximity and range sensors:** (optical sensors, acoustical sensors, electromagnetic sensors).
- iii. **Miscellaneous sensors:** (transducers and sensors which sense variables such temperature, pressure, fluid flow, thermocouples, voice sensors) Machine vision systems [7].

### 2.3 Internet of Things

The Internet of Things (IoT) refers to the evolutionary stage of the internet, which makes a global communicating infrastructure between humans and machines. IoT is constructing the global infrastructure which will change the fundamental aspects of our lives, from health services to manufacturing, from agriculture to mining. IoT will offer the necessary facilities of the latest rising artificial intelligence (AI) development. IoT has grown to be a marketing trend and general news piece. Beyond exaggeration, IoT appeared as a powerful technique with appliances in numerous domains. IoT has origins in multiple former methods: sensor networks, embedded systems and pervasive informatics. Many IoT devices are linked mutually to develop specific purpose schemes; in the global network, they are rarely utilized as public access devices. An IoT node is a sensor contained hardware piece that broadcasts sensed information to users or any other devices over the internet. IoT nodes embed into industrial equipment, mobile and medical instruments, wireless sensors, and more. Top examples of IoTs are connected smart

city, smart industry, smart transport, smart buildings [8], smart energy, smart manufacturing, smart environment monitoring, smart living, smart health, smart food and water monitoring. Figure 2.1 shows the IoT network architecture. This architecture has a lot of IoT sensors for sensing purposes such as temperature, humidity, pressure etc. After sensing, these data are transmitted to a cloud server via an IoT gateway. Furthermore, users can access these data through mobile apps and so on. Due to the accessibility of low cost and smart devices, the IoT network refers to a smart system. IoT devices operate independently with their hearing and transmission abilities. Furthermore, the propagation of IoT provides a lot of benefits but also provides potential threats. An overlooked factor so far is the rise in energy expenditure. IoT nodes are anticipated to always be accessible on other nodes[8].

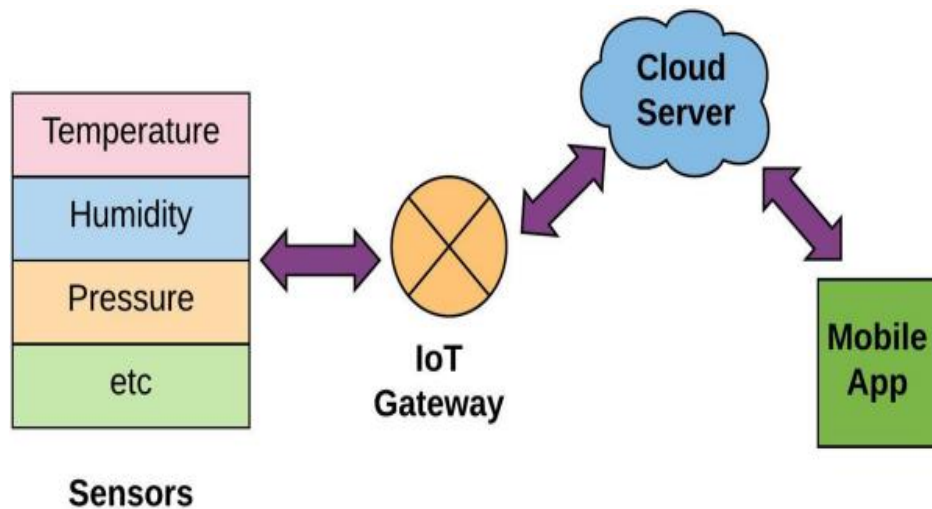

**Figure 2.1:** IoT network architecture.

### 2.3.1 IoT benefits:

- i. **Locating and tracing abilities:** Customers should be capable of tracking the nodes and locating them in a short amount of time.
- ii. **Ubiquitous information swap:** In IoT where nodes are linked to the internet and where information is transmitted. Ubiquitous means intelligence. Therefore, intelligence sensors collect information and transmit it using a prearranged input.
- iii. **Enhanced power solution:** Customers should be capable of tracking even the strongest node, and the customer should be capable of obtaining the best result.
- iv. **Data and intelligence management:** IoT does not always require providing commands to the instrument; where the node gives intelligence and information previously it can start working and obtains decisions and discovers solutions based on intelligence.
- v. **Scalability:** IoT should be the measurability, as with any number of IoT nodes above an extensive network all nodes should distinguish uniquely.
- vi. **Unprotected authorization/authentication:** The administrator usually presents authentication to verify the customer identity, and the authorization utilizes rewriting or modifying the content for that appliance and the consent that the administrator will give.
- vii. **The technology of server:** The number of IoT nodes over the IoT field increases the demand and the number of IoT node replies, moreover increases simultaneously depending entirely on the server where customers use the interface. The server response to the IoT node demand should be made immediately. There must be no delay in responding to the customer.

- viii. **Management of storage:** A massive quantity of information is created. When connected IoT nodes have a massive quantity of multimedia data transmitted, they have big data and other types of inconsistent files where data is held concerning these IoT nodes, these files do not take much space. Still, many of them should be useable as soon as possible.
- ix. **Data management:** As transmission between nodes is completed, more information is created daily between nodes, and there is more information to be transmitted from one location to another. Consideration should be given to whether specific information is transmitted or not.
- x. **Security:** Provision of security can be challenging as the automation of nodes has increased, which has generated novel security problems[8].

### 2.3.2 Applications

IoT can be used in many real world applications; some of the most prominent field of applications is;

#### a) Smart City

Smart city is one of the powerful application of IoT through which automatic transportation, water management , pollution control, traffic route updates , smart parking for vehicles , smart surveillance, identifying water leakages , saving necessary resources such as electricity and water. Overall people can enjoy a complete and secured environment.

### **b) Smart Retail and Efficient Energy Utilization**

IoT provides good opportunity for the retailers to communicate with the customer, through which they can enhance their experience of shopping. It is executed through the product preference by the customer.

### **c) IoT in Agriculture and Greenhouse**

The demand of food products is a big challenge; IoT gives a solution to farmers to get better productivity in their agricultural land, shares knowledge to farmers about climate, soil and water level to get good yield in their crop.

### **d) IoT in patient care**

IoT plays a vital role in health care industry, by tracking patient's health each and every second, RFID technique plays an important role in collecting patient's information even though if he/she resides in the remote place from where hospital is situated, their health data can be maintained and any issues can be attended then and there. Elderly pupil can also be taken care through this.

### **e) IoT in Farm animals monitoring**

The behavior and health conditions of farm animals can be monitored and tracked even from the remote places with the help of IoT.

### **f) IoT in Industries**

Industries with devices were the major source of producing large amount of data, termed as big data in order to utilize the data efficiently and effectively and to make efficient decision which is useful for business; those data need to be analyzed called as big data analytics[9].



## **2.4 Wireless Sensor Network in Greenhouse**

A wireless sensor network (WSN) consists of spatially distributed autonomous sensors to monitor physically or environmental conditions, such as temperature, sound, vibration, pressure, motion or pollutants and to cooperatively pass their data through the network to a main location. WSN can be used in some special situation for signal collection, processing and transmitting. Wireless technologies have been rapidly developed during recent years. Its advantages include the liability, simplicity, and low cost in both installation and maintenance. WSN can form a useful part of the automation system architecture in modern greenhouse. Wireless communication can be used to collect the measurement and to communicate between the centralized control and the actuators located in the different parts of the greenhouse. Compared to the cabled systems, the installation of WSN is fast, cheap and easy. Moreover, it is easy to relocate the measurement points when needed by just moving sensor nodes from one location to another within a communication range of the coordinator device. WSN maintenance is also relatively cheap and easy. The only additional cost occur when the sensor nodes run out of batteries and the batteries need to be charged or replaced, but the lifespan of the battery can be several years if an efficient power saving algorithm is applied. A wireless sensor network

Consists small size wireless sensor nodes equipped with radio and one or several sensors in an attractive and cost efficient option to build the required measurement system. Wireless technologies have been rapidly developed during recent years. There are a few types of wireless communication technologies which is ZigBee, Wi-Fi and Bluetooth. Wi-

Fi, Bluetooth and Zigbee work at similar RF frequencies, and their application sometimes overlaps [10].

#### **2.4.1 Characteristics of WSN**

It uses low power, less memory, limited energy because of its small size. It can be utilized effectively in harsh environment condition for example in too hot/ in too cold. It does not follow any specific structure. It is constantly reconfigured. Power consumption is the only constraints; due to the usage of batteries it can be saved. Heterogeneity of nodes gives the ability to cope with node failure and easy usage[9].

#### **2.4.2 Applications of WSN**

WSN is practiced in many places, predominantly in establishing smart home or smart office where sensors are used to control appliances and electrical devices, for example automatically switching off / switching on the lights, it paves the way for saving the source of electrical energy. In Biomedical / Medical it is used for monitoring glucose , heart rate , cancer detection any chronic diseases can also be implemented for hospital sensors For monitoring vital signs, record anomalies, also used in agricultural crop for inventory tracking , automated problem reporting., better plant maintenance. RFID is also used for theft detection. Monitoring over a region seems to be a common application of WSN. For example military is an example where the enemy's intrusion can be monitored and alarm can be raised as a sign of emergency However it can be used to monitor climate both in indoor and outdoor It also helps to monitor the animals habitat. It also helps to track our asset, It can be used in disaster management, health monitoring and soon[9].

## 2.5 Microcontrollers

A microcontroller is a highly integrated functional computer system on a chip, it contains an integrated memory and programmable I/O peripherals, Microcontroller s often operate at very low speed. They consume relatively little power. It is used to control the motor activation and deactivation operation and also reads sensors signals[11].

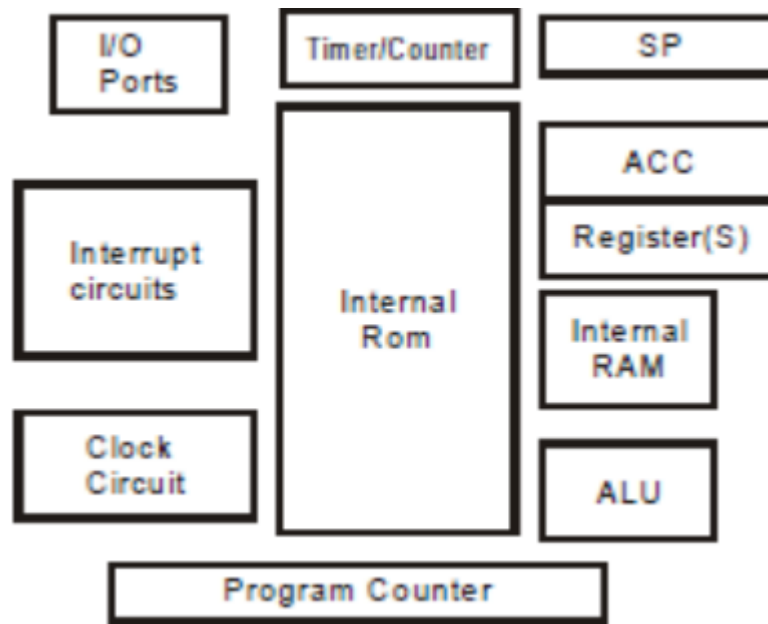

**Figure 2.2:** A block diagram of a microcontroller.

### Types of Microcontrollers

Microcontrollers come in many varieties. Depending on the power and features that are needed, one might choose a 4 bit, 8 bit, 16 bit, or 32 bit microcontroller. In addition, some specialized versions are available which include features specific for communications, keyboard handling, signal processing, video processing, and other tasks. One of the examples of different types of commercial microcontroller devices are given in the Arduino [12].

### **2.5.1 Arduino:**

Arduino is a small microcontroller board with a USB plug to connect to computer and a number of connection sockets that can be Wired up to external electronics, such as motors, relays, light sensors, laser diodes, loudspeakers, microphones ,etc.

The name “Arduino” is reserved by the original makers. However, clone Arduino designs often have the letters “duino” on the end of their name, for example, Freeduino or DFRduino. The software for programming your Arduino is easy to use and also freely available for Windows, Mac, and LINUX computers at no cost. The first Arduino was introduced in 2005, aiming to provide a low cost, easy way for novices and professionals to create devices that interact with: their environment using sensors and actuators [13].

#### **Arduino Hardware**

An Arduino board historically consists of an Atmel 8-, 16- or 32-bit AVR microcontroller, it complementary components that facilitate programming and incorporation into other circuits. An important aspect of the Arduino is its standard connectors, which let users connect the CPU board to a variety of interchangeable add-on modules termed *shields*. Some shields communicate with the Arduino board directly over various pins, but many shields are individually addressable via an I<sup>2</sup>C serial bus—so many shields can be stacked and used in parallel. Before 2015, Official Arduino had used the Atmel megaAVR series of chips, specifically the ATmega8, ATmega168, ATmega328, ATmega1280, and ATmega2560 [13].

## Types of Arduino:

There are, in fact, several different designs of Arduino board. These are intended for different types of applications. They can all be programmed from the same Arduino development software, and the types are:

### i. **Arduino Uno:**

Is a microcontroller board based on the ATmega328, The Arduino Uno has 14 digital input/output pins (of which 6 can be used as PWM outputs), 6 analog inputs, a 16 MHz crystal oscillator, a USB connection, a power jack, an ICSP header, and a reset button. It contains everything needed to support the microcontroller; simply connect it to a computer with a USB cable or power it with a AC-to-DC adapter or battery to get started, the most common version of Arduino is the Arduino Uno [13].

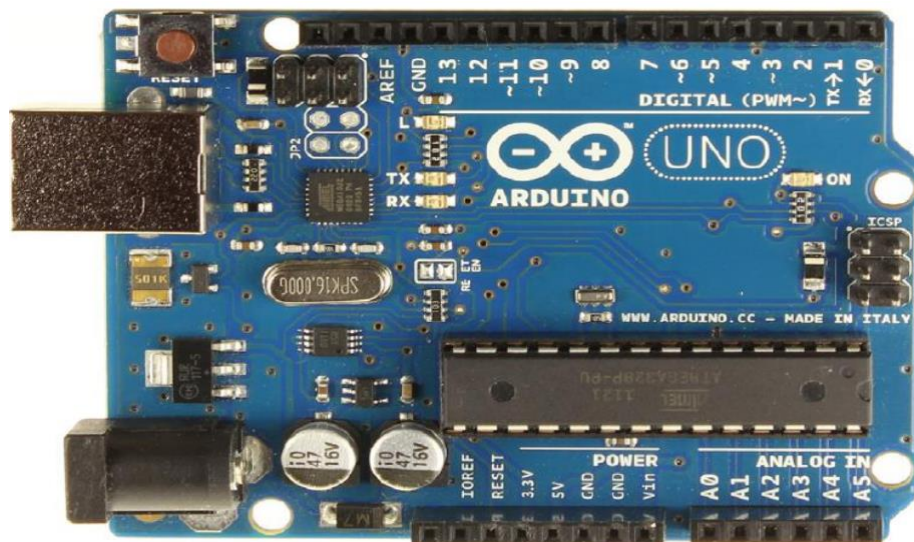
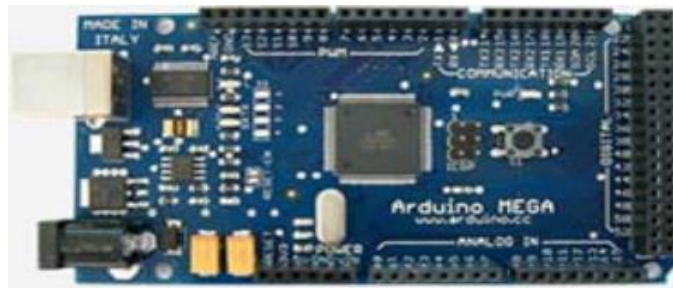

Figure 2.3: Arduino Uno.

ii. **Arduino Mega:**

The Mega is the second most commonly encountered version of the Arduino family. The Arduino Mega is like the Arduino Uno's beefier older brother. It boasts 256 KB of memory (8 times more than the Uno). It also had 54 input and output pins, 16 of which are analog pins, and 14 of which can do PWM. However, all of the added functionality comes at the cost of a slightly larger circuit board.



**Figure 2.4:** Arduino Mega.

iii. **Arduino LilyPad:**

The LilyPad was designed for wearable and e-textile applications. It is intended to be sewn to fabric and connected to other sewable components using conductive thread. This board requires the use of a special FTDI-USB TTL serial programming cable.

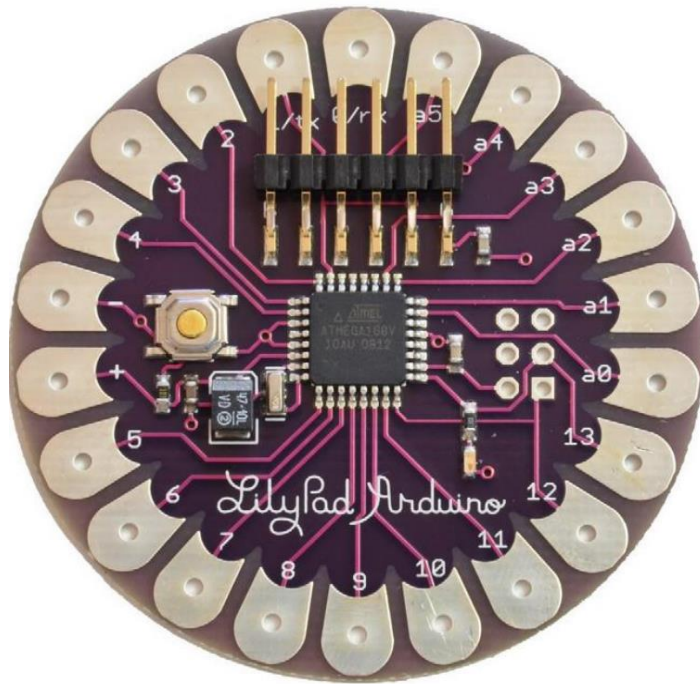

**Figure 2.5:** Arduino LilyPad

**iv. Arduino Nano:**

The Arduino Nano is a small, complete, and breadboard-friendly board based on the ATmega328 or ATmega168. It has more or less the same functionality of the Arduino Duemilanove, but in a different package. It lacks only a DC power jack, and works with a Mini-B USB cable instead of a standard one. [13]



**Figure 2.6:** Arduino Nano.

## **2.6 Related works:**

There are many previous studies in this area which should be reviewed for helping in proposing a system with solvable problem in greenhouses.

Othman and Shazali [14] have discussed and reviewed wireless sensor network applications for environmental monitoring. Development in the technology of sensor such as Micro Electro Mechanical Systems (MEMS), wireless communications, embedded systems, distributed processing and wireless sensor applications have contributed a large transformation in WSN recently. It assists and improves work performance both in the field of industry and our daily life. Wireless sensor network has been widely used in many areas especially for surveillance and monitoring in agriculture and habitat monitoring. Environment monitoring has become an important field of control and protection, providing real-time system and control communication with the physical world. An intelligent and smart Wireless Sensor Network system can gather and process a large amount of data from the beginning of the monitoring and manage air quality, the conditions of traffic, to weather situations in the monitoring system [14].

Berezowski [15] has reviewed the landscape of the application of wireless sensor networking in greenhouse management to make computer engineer more aware about this specific application domain and the space it offers for applying IT and communication infrastructure, as well as to make horticulture researchers more aware of what wireless technologies have to offer and how to optimize their usage in the greenhouse. Also identified, formulated and discussed the design space of a few in opinion most important problems in developing efficient and cost effective WSN deployments for greenhouses. The reasons to



propose such an analysis have come from the gap have observed between the results observations coming from preliminary field experimentation in the greenhouse [15].

Hwang and Yu [16] have proposed design and implementation of a remote monitoring and controlling system using ZigBee networks. This system is targeting the home network. Web service and a smart phone are used for the client system to monitor and control the home. This system can be applied in many areas such as elderly protecting systems, cultural heritage or forest fire monitoring systems, managing systems for agricultural cultivation and so on [16].

Sahu and Mazumdar [17] have designed a simple, easy to install, microcontroller-based (Atmel) circuit to monitor and record the values of temperature, humidity, soil moisture and sunlight of the natural environment that are continuously modified and controlled in order optimize them to achieve maximum plant growth and yield. The microcontroller communicates with the various sensor modules in realtime in order to control the light, aeration and drainage process efficiently inside a greenhouse by actuating a cooler, fogger, dripper and lights respectively according to the necessary condition of the crops. An integrated Liquid Crystal Display (LCD) is also used for real time display of data acquired from the various sensors and the status of the various devices [17].

Alausa Dele and Kolawole [18] have proposed microcontroller based greenhouse control device is used in the automatic control and monitoring of Equipments and quantities such as screening installations,

heating, cooling, lighting, temperature, soil Moisture level and other quantities/conditions in a greenhouse, with effective monitoring of all quantities therein, hence eliminating need for Human monitoring. With an enhanceable feature it integrates and automates by turning ON or OFF all monitoring devices in the house as well as provides suggestions for remedies when the need arises. The system has successfully overcome quite a few short comings of the existing systems by reducing the power consumption, maintenance and complexity, at a reduced cost and at the same time providing a flexible and precise form of maintaining the environment [18].

Mohanty and Patil [18] have proposed some important parameters that should be monitored at a greenhouse in order to achieve good results at the end of the agricultural production such as temperature, light and humidity. And have presented a wireless sensor network having several sensor nodes with these commercial sensors to measure the above parameters. The system can efficiently capture greenhouse environmental parameters and it shows normal communication between source and sink node and fine network stability. It also obtains strong adaptability, good confidentiality and high reliability. So will developed greenhouse wireless sensor network monitoring system design based on solar energy. The sensor nodes receive the solar energy and supply it to the wireless sensor network. The design will consume less energy and cost effective [18].

Nikhade and Nalbalwar [19] have summarized an idea that can carry out to provide an efficient control mechanism of microclimate into greenhouses through the implementation of an infrastructure of wireless

sensors network to control environmental parameters. This enables a real time action process that aims to atomise the network tasks. Based on the advantage gained from the small size of the network, low cost distributed sensing network that can be employed anywhere and even with harsh environments greenhouse crops are in essential neediness for WSN system which achieve better monitoring-controlling and hence avoiding damage of the crops due to unstable inside parameters like temperature, humidity, soil moisture, leaf temperature and many other parameters which affects crops growth and may cause of diseases. The design is more focusing on automation jobs, optimizing the response time, and providing instant solution [19].

Gao et al [20] have designed a wireless greenhouse monitoring system based on ZigBee and GSM technology to resolve the problems of complicated cabling and costly wired network in the current system. The system consists of two parts: a wireless sensor network and remote control terminal. According to parameter distribution in the monitoring regional, a wireless transmission network was formed, all of the nodes in the network using solar power. In the remote control terminal, the study developed a simplified expert decision system, in which the part of greenhouse control decision adopts the fuzzy decoupling control algorithm to realize the temperature and humidity decoupling control and increase the accuracy of decision-making according to the experimental test. It can realize real-time, accurate monitoring and collecting of parameters data in the greenhouse environment; the remote control terminal can give effective decision management solutions. The system achieves automatic real-time monitoring of environmental parameters and gives correct decision plans, which is of a broad application prospect.

Jianjun et al [21] has presented system that consists of a data acquisition controller and greenhouse remote monitoring and control software. The system, monitor temperature ,humidity, soil water content and concentration of carbon dioxide inside the greenhouse which then saved to a database. According to the current indoor temperature, the target temperature and the offset temperature, Proportional Integral and Derivative (PID) control method is used to control temperature control in greenhouse. The system is implemented using low power wireless components, and easy to be installed [21].

Keerthi et al.[9] Implements of an electronic system based GSM (Global System for Mobile communication), cloud computing and IoT for sensing climatic parameters of green house. A real-time environmental information for crop growth, focused on developing a system that can automatically measure and monitor changes of temperature, light, humidity, moisture level in green house. Parameters collected for every 30 seconds. The complete module is of low cost, low power operation, more over easily available to everyone. Parameters are stored and retrieved for real time processing using cloud IoT.

## **CHAPTER THREE**

### **METHODOLOGY**

# Chapter Three: Methodology

## 3.1 System Block Diagram

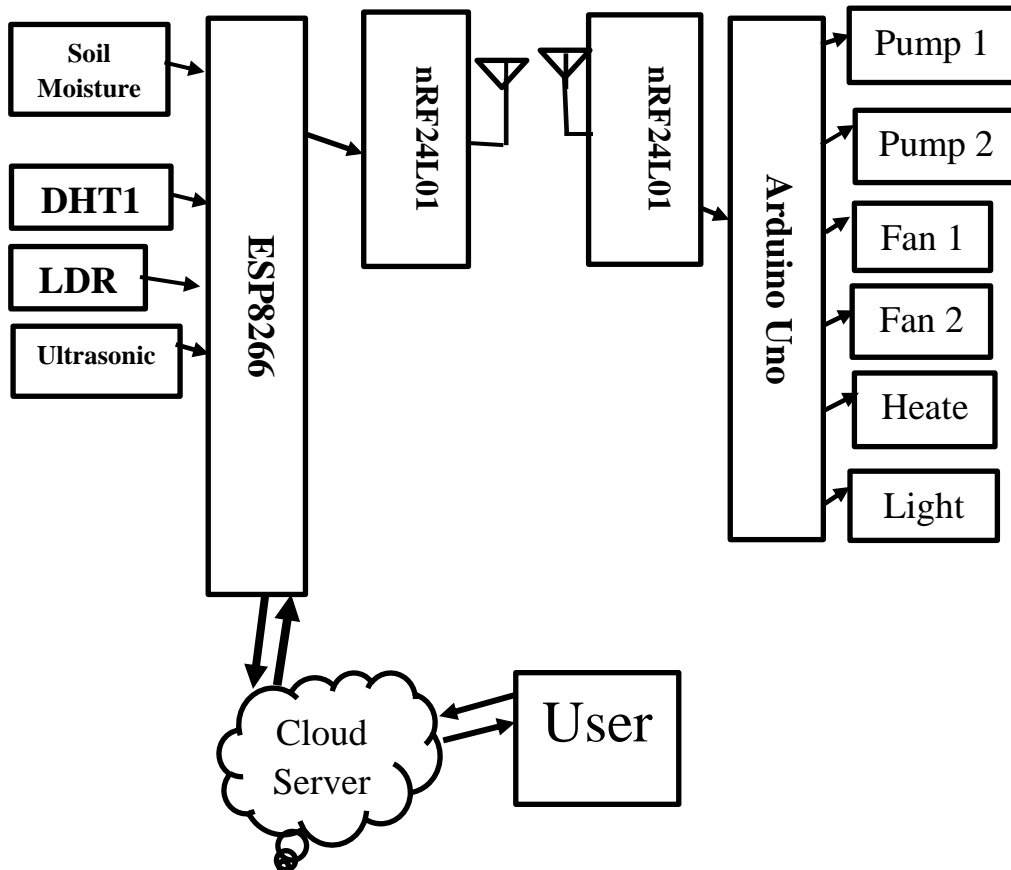

Figure 3.1: block diagram of greenhouse management system.

## 3.2 Sensing Unit:

Sensors provide input information for the automation system by measuring the climate variables of the greenhouse. Five parameters are monitored in this study namely; temperature, humidity, light, the amount of water and soil moisture.

### 3.2.1 DHT11 Humidity & Temperature Sensor:

DHT11 Temperature & Humidity Sensor features a temperature & humidity sensor complex with a calibrated digital signal output. By using the exclusive digital-signal-acquisition technique and temperature & humidity sensing technology, it ensures high reliability and excellent long-term stability. This sensor includes a resistive-type humidity measurement component and an NTC temperature measurement component, and connects to a high performance 8-bit microcontroller, offering excellent quality, fast response, anti-interference ability and cost-effectiveness[22].

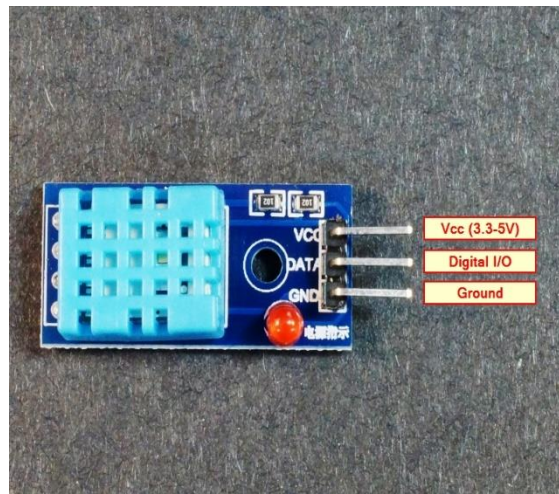

**Figure 3.2:** DHT11 Sensor

Each DHT11 element is strictly calibrated in the laboratory that is extremely accurate on humidity calibration. The calibration coefficients are stored as programs in the OTP memory, which are used by the sensor's internal signal detecting process. The single-wire serial interface makes system integration quick and easy. Its small size, low power consumption and up-to-20 meter signal transmission making it the best choice for various applications, including those most demanding ones. The

component is 4-pin single row pin package. It is convenient to connect and special packages can be provided according to users' request.

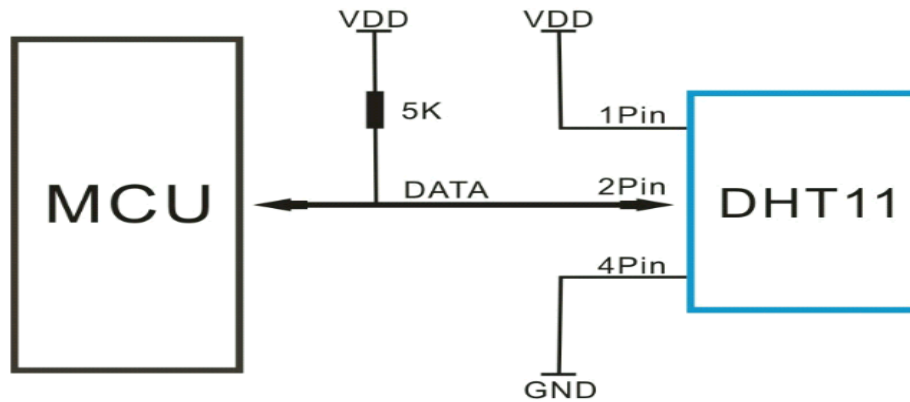

**Figure 3.3:** Typical Application

**Note:** 3Pin – Null; MCU = Micro-computer Unite or single chip Computer

When the connecting cable is shorter than 20 meters, a 5K pull-up resistor is recommended; when the connecting cable is longer than 20 meters, choose an appropriate pull-up resistor as needed.

**- 4Pin. Power and Pin**

DHT11's power supply is 3-5.5V DC. When power is supplied to the sensor, do not send any instruction to the sensor in within one second in order to pass the unstable status. One capacitor valued 100nF can be added between VDD and GND for power filtering.

**Overall Communication Process (Figure 3.4, below):**

When MCU sends a start signal, DHT11 changes from the low-power-consumption mode to the running-mode, waiting for MCU completing the start signal. Once it is completed, DHT11 sends a response signal of 40-bit data that include the relative humidity and temperature information to MCU. Users can choose to collect (read) some data. Without the start signal from MCU, DHT11 will not give the response signal to MCU. Once



data is collected, DHT11 will change to the low power-consumption mode until it receives a start signal from MCU again[22].

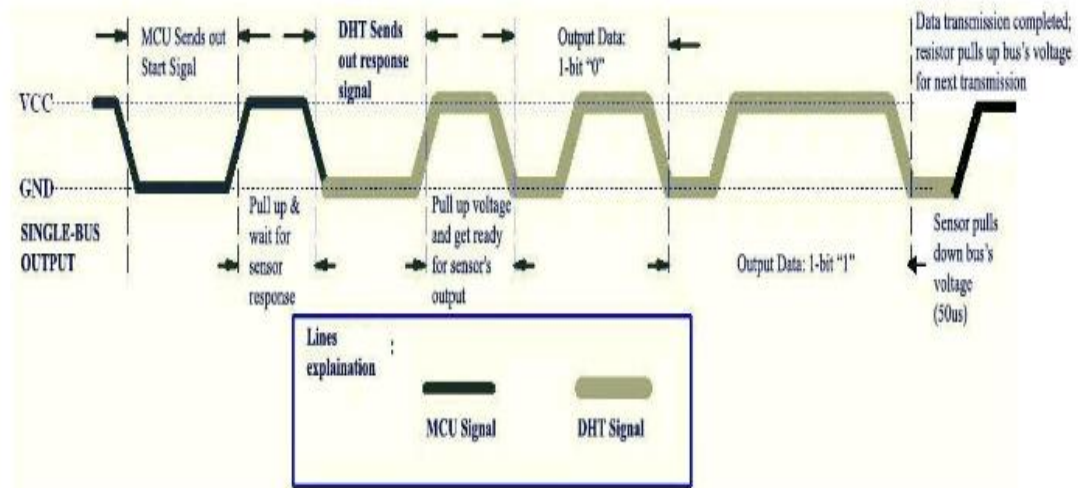

**Figure 3.4:** Overall Communication Process

**Table 3.1:** Technical Specification of DHT11

Specification	Value
Resolution	1
Response time Temperature /Humidity	30 S /10 S
Accuracy Temperature /Humidity	$\pm 2^{\circ}\text{C}$ / $\pm 5\% \text{RH}$
Range Temperature/ Humidity	0-50 $^{\circ}\text{C}$ / 20-90%RH
Power supply	DC 3.5~5.5V
Sampling period	more than 2 seconds

### 3.2.2 Ultrasonic sensor:

Ultrasonic sensors work by emitting sound waves at a frequency which is too high for humans to hear. Ultrasonic sensors emit short, high-frequency sound pulses at regular intervals. These propagate in the air at the velocity of sound. If they strike an object, then they reflected back as an echo signals to the sensor, which itself computes the

distance to the target based on the time-span between emitting the signal and receiving the echo.



**Figure 3.5:** Ultrasonic sensor

An above image shows the HC-SR-04 ultrasonic sensor which has transmitter, receiver. The pin configuration is:

- VCC – +5 V supply
- TRIG – Trigger input of sensor. Microcontroller applies 10 us trigger pulse to the HC-SR04 ultrasonic module
- ECHO–Echo output of sensor. Microcontroller reads/monitors this pin to detect the obstacle or to find the distance.
- GND – Ground

Sound is a mechanical wave traveling through the mediums, which may be a solid, or liquid or gas. Sound waves can travel through the mediums with specific velocity depends on the medium of propagation. The sound waves which are having high frequency reflect from boundaries and produce distinctive echo patterns.

## Timing Diagram of Ultrasonic Sensor

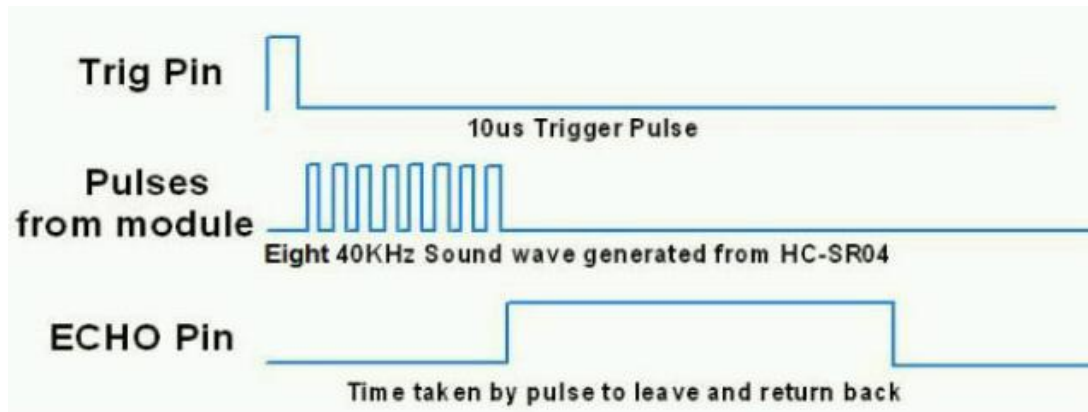

**Figure 3.6:** Timing Diagram of Ultrasonic sensor

1. First need to transmit trigger pulse of at least 10 us to the HC-SR04 Trig Pin.
2. Then the HC-SR04 automatically sends Eight 40 kHz sound wave and wait for rising edge output at Echo pin.
3. When the rising edge capture occurs at Echo pin, start the Timer and wait for falling edge on Echo pin.
4. As soon as the falling edge captures at the Echo pin, read the count of the Timer. This time count is the time required by the sensor to detect an object and return back from an object[23].

### Technical Specifications:

1. Power Supply – +5V DC
2. Quiescent Current – <2mA
3. Working Current – 15mA
4. Effectual Angle – <15°
5. Ranging Distance – 2cm – 400 cm/1" – 13ft
6. Resolution – 0.3 cm
7. Measuring Angle – 30 degree

### 3.2.3 Soil moisture

Soil moisture sensors measure the water content in the soil and can be used to estimate the amount of stored water in the soil horizon. Soil moisture sensors do not measure water in the soil directly. Instead, they measure changes in some other soil property that is related to water content in a predictable way.

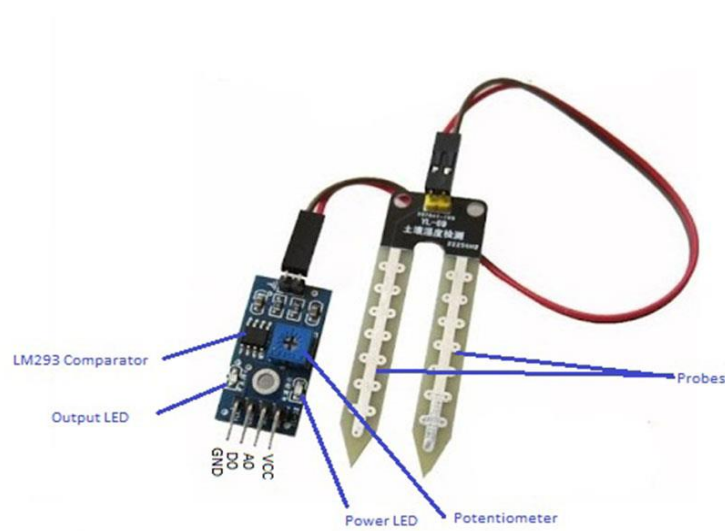

**Figure 3.7:** Soil moisture sensor

### **The structure of the sensor:**

The design of the structure of the soil moisture sensor was shown in Figure.

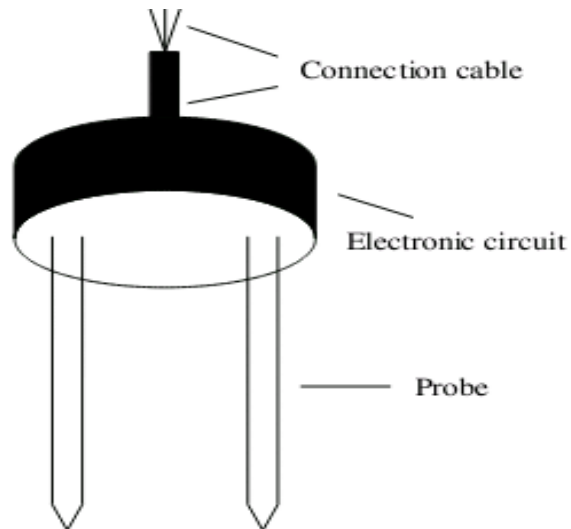

**Figure 3.8:** Appearance structure of soil moisture sensor

The probe electrode composed of a printed circuit board has two pin-type parallel structures and was electrically connected to the electronic circuit equipped with sensors, and was highly integrated to form an integrated structure. The probe ends were designed to be triangular in order to be easily inserted into the soil to be tested. After filling, the electronic circuit area was sealed with a rubber shell. Only a shielded three core wire was used as the external interface. The three core lines were respectively connected to the power input of the sensor, the ground wire and the signal output line[24].

### **3.2.4 Light Dependent Resistor**

A light dependent resistor also known as a LDR, photo resistor, photoconductor or photocell, is a resistor whose resistance increases or decreases depending on the amount of light intensity. LDRs (Light Dependent Resistors) are a very useful tool in a light/dark circuits. LDRs can have a variety of resistance and functions. For example it can be used

to turn on a light when the LDR is in darkness or to turn off a light when the LDR is in light. It can also work the other way around so when the LDR is in light it turns on the circuit and when it's in darkness the resistance increase and disrupts the circuit.

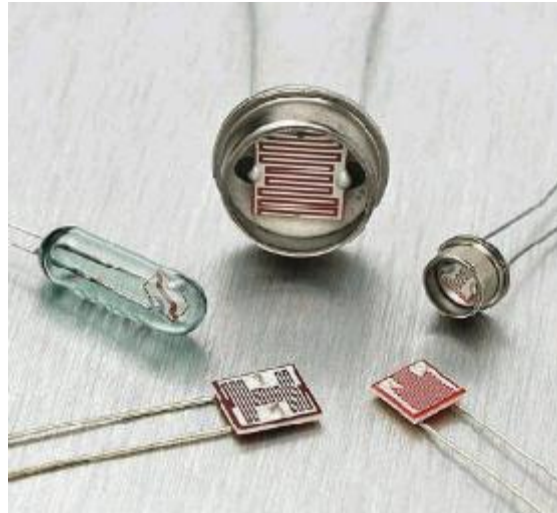

**Figure 3.9:** Light Dependent Resistor

### **How it Works:**

The way an LDR works is that they are made of many semi-conductive materials with high resistance. The reason they have a high resistance is that there are very few electrons that are free and able to move because they are held in a crystal lattice and are unable to move. When light falls on the semi-conductive material it absorbs the light photons and the energy is transferred to the electrons, which allow them to break free from the crystal lattice and conduct electricity and lower the resistance of the LDR.

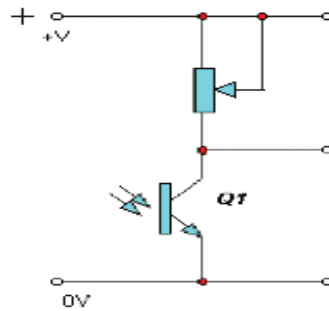

**Figure 3.10:** The Circuit of LDR

**Table 3.2:** Technical Specification of LDR

Specification	Value
Voltage ,AC or DC peak	320V
Current	75Ma
Power Dissipation at 30°C	250mW
Operating temperature range	-60°C to 75°C

### 3.3 Processing Unit

#### 3.3.1 Arduino Uno:

The Arduino Uno is a microcontroller board based on the ATmega328. It has 14 digital input/output pins (of which 6 can be used as PWM outputs), 6 analog inputs, a 16 MHz ceramic resonator, a USB connection, a power jack, an ICSP header, and a reset button. It contains everything needed to support the microcontroller; simply connect it to a computer with a USB cable or power it with an AC-to-DC adapter or battery to get started. The Uno differs from all preceding boards in that it does not use the FTDI USB-to-serial driver chip.

Instead, it features the Atmega16U2 (Atmega8U2 up to version R2) programmed as a USB-to-serial converter. "Uno" means one in Italian and is named to mark the upcoming release of Arduino 1.0. The Uno and version 1.0 will be the reference versions of Arduino, moving forward. The Uno is the latest in a series of USB Arduino boards[25].

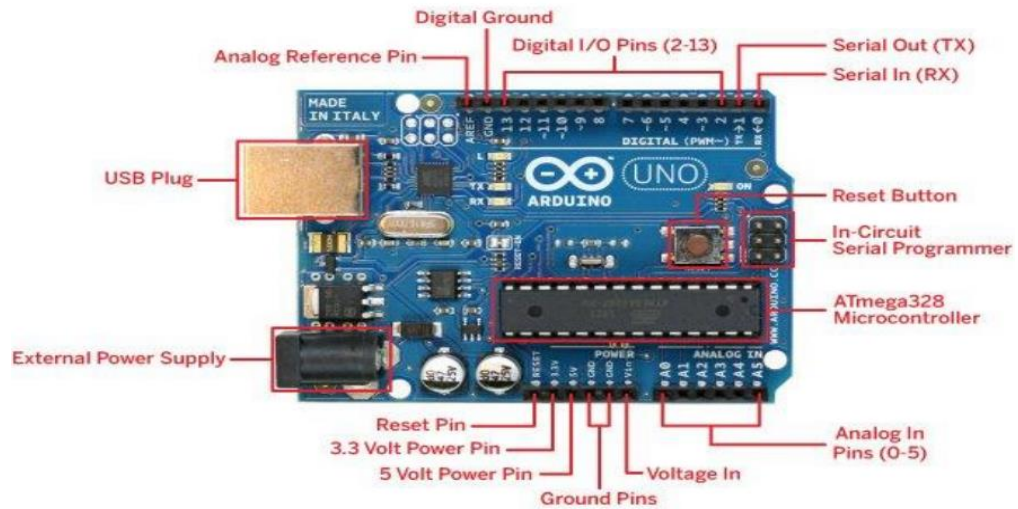

**Figure 3.11:** Arduino Uno

### Summary

Microcontroller	ATmega328
Operating Voltage	5V
Input Voltage (recommended)	7-12V
Input Voltage (limits)	6-20V
Digital I/O Pins	14 (of which 6 provide PWM output)
Analog Input Pins	6
DC Current per I/O Pin	40 mA
DC Current for 3.3V Pin	50 mA
Flash Memory	32 KB (ATmega328) of which 0.5 KB
SRAM	2 KB (ATmega328)
EEPROM	1 KB (ATmega328)
Clock Speed	16 MHz

### 3.3 Wireless communication unit

To collect data from sensing unit and are monitored in the control unit to provide the appropriate conditions for the plant is a wireless communication where **nRF24L01** wireless module were selected.



### **3.3.1 nRF24L01:**

The nRF24L01 is a single chip 2.4GHz transceiver with an embedded baseband protocol engine (Enhanced ShockBurst™), designed for ultra-low power wireless applications. The nRF24L01 is designed for operation in the world wide ISM frequency band at 2.400 - 2.4835GHz. An MCU (microcontroller) and very few external passive components are needed to design a radio system with the nRF24L01. The nRF24L01 is configured and operated through a Serial Peripheral Interface (SPI.) Through this interface the register map is available. The register map contains all configuration registers in the nRF24L01 and is accessible in all operation modes of the chip. The embedded baseband protocol engine (Enhanced ShockBurst™) is based on packet communication and supports various modes from manual operation to advanced autonomous protocol operation. Internal FIFOs ensure a smooth data flow between the radio front end and the system's MCU. Enhanced ShockBurst™ reduces system cost by handling all the high-speed link layer operations. The radio front end uses GFSK modulation. It has user configurable parameters like frequency channel, output power and air data rate. The air data rate supported by the nRF24L01 is configurable to 2Mbps. The high air data rate combined with two power saving modes makes the nRF24L01 very suitable for ultra-low power designs. Internal voltage regulators ensure a high Power Supply Rejection Ratio (PSRR) and a wide power supply range[26].

## **FEATURES:**

Features of the nRF24L01 include:

- Radio

- Worldwide 2.4GHz ISM band operation

- 126 RF channels

- Common RX and TX pins

- GFSK modulation

- 1 and 2Mbps air data rate

- 1MHz non-overlapping channel spacing at 1Mbps

- 2MHz non-overlapping channel spacing at 2Mbps

- Transmitter

- Programmable output power: 0, -6, -12 or -18dBm

- 11.3mA at 0dBm output power

- Receiver

- Integrated channel filters

- 12.3mA at 2Mbps

- 82dBm sensitivity at 2Mbps

- 85dBm sensitivity at 1Mbps

- Programmable LNA gain

- RF Synthesizer

- Fully integrated synthesizer

- No external loop filter, VCO varactor diode or resonator

- Accepts low cost  $\pm 60$ ppm 16MHz crystal

- Enhanced ShockBurst™

- 1 to 32 bytes dynamic payload length

- Automatic packet handling

- Auto packet transaction handling

- 6 data pipe MultiCeiver™ for 1:6 star networks

- Power Management

Integrated voltage regulator.

1.9 to 3.6V supply range.

Idle modes with fast start-up times for advanced power management

22uA Standby-I mode, 900nA power down mode

Max 1.5ms start-up from power down mode

Max 130us start-up from standby-I mode

- Host Interface

4-pin hardware SPI

Max 8Mbps

3 separate 32 bytes TX and RX FIFOs

5V tolerant inputs

- Compact 20-pin 4x4mm QFN package[26]

### BLOCK DIAGRAM:

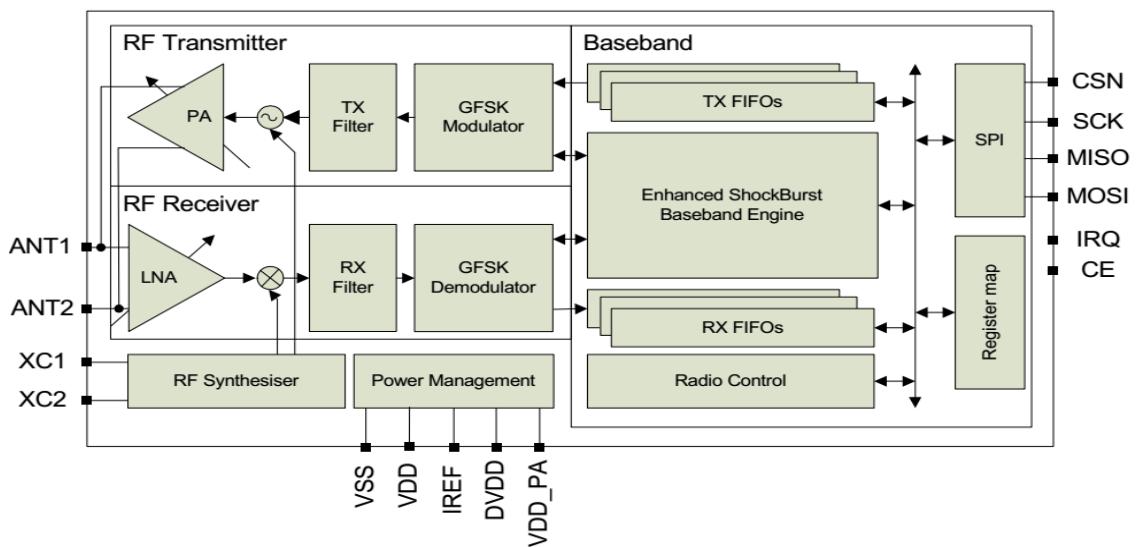
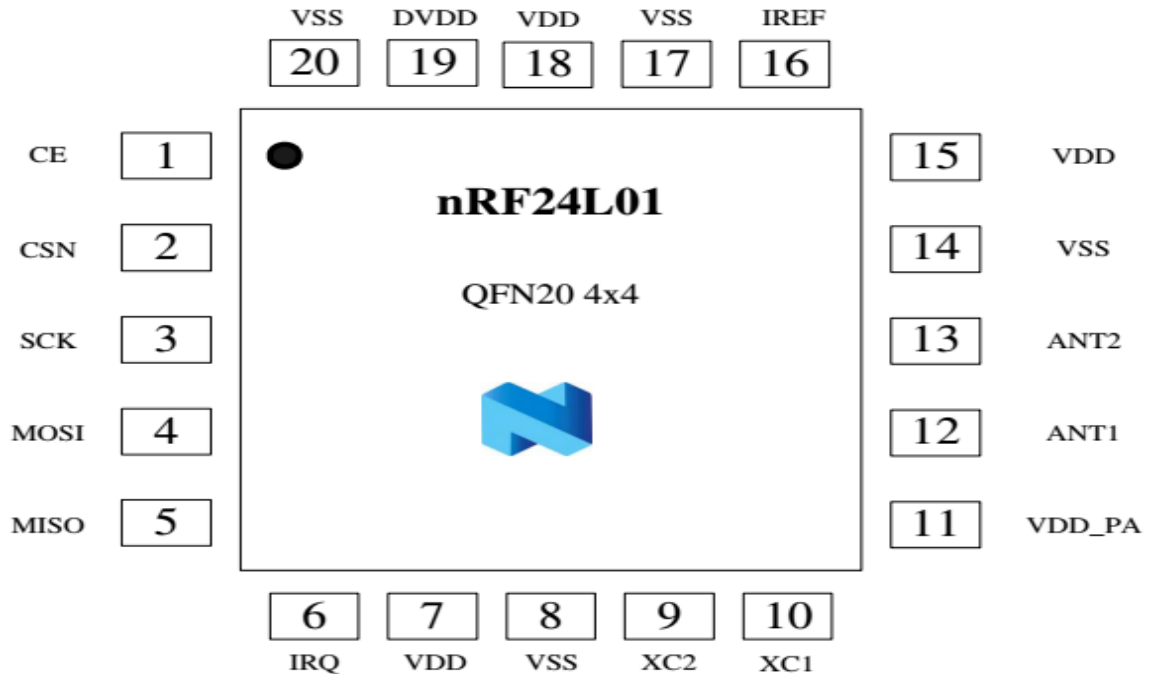

Figure 3.12: nRF24L01 block diagram

## PIN Information:

### 1. PIN ASSIGNMENT



**Figure 3.13:** nRF24L01 pin assignment (top view) for a QFN20 4x4 package.

### 2. PIN FUNCTIONS

**Table 3.3:** nRF24L01 pin function

Pin	Name	Pin function	Description
1	CE	Digital Input	Chip Enable Activates RX or TX mode
2	CSN	Digital Input	SPI Chip Select
3	SCK	Digital Input	SPI Clock
4	MOSI	Digital Input	SPI Slave Data Input
5	MISO	Digital Output	SPI Slave Data Output, with tri-state option
6	IRQ	Digital Output	Maskable interrupt pin
7	VDD	Power	Power Supply (+3V DC)
8	VSS	Power	Ground (0V)
9	XC2	Analog Output	Crystal Pin 2
10	XC1	Analog Input	Crystal Pin 1
11	VDD_PA	Power Output	Power Supply (+1.8V) to Power Amplifier
12	ANT1	RF	Antenna interface 1
13	ANT2	RF	Antenna interface 2
14	VSS	Power	Ground (0V)
15	VDD	Power	Power Supply (+3V DC)
16	IREF	Analog Input	Reference current
17	VSS	Power	Ground (0V)

18	VDD	Power	Power Supply (+3V DC)
19	DVDD	Power Output	Positive Digital Supply output for de-coupling purposes
20	VSS	Power	Ground (0V)

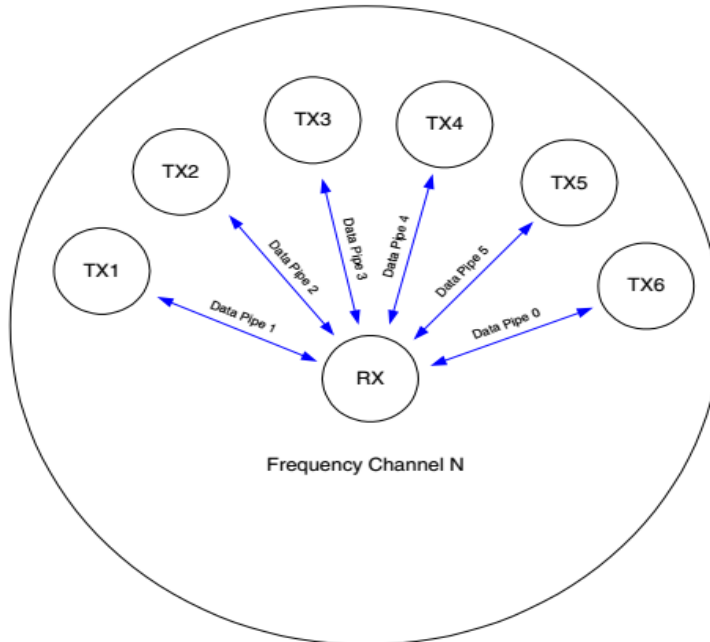

**Figure 3.14:** nRF24L01 in a star network configuration

An nRF24L01 configured as primary RX (PRX) will be able to receive data through 6 different data pipes, see **Figure 4.14**. A data pipe will have a unique address but share the same frequency channel. This means that up to 6 different nRF24L01 configured as primary TX (PTX) can communicate with one nRF24L01 configured as PRX, and the nRF24L01 configured as PRX will be able to distinguish between them. Data pipe 0 has a unique 40 bit configurable address. Each of data pipe 1-5 has an 8 bit unique address and shares the 32 most significant address bits. All data pipes can perform full Enhanced ShockBurst™ functionality. nRF24L01 will use the data pipe address when acknowledging a received packet. This means that nRF24L01 will transmit ACK with the same address as it receives payload at. In the PTX device data pipe 0 is used to receive the acknowledgement, and therefore the receive address for data pipe 0 has to

be equal to the transmit address to be able to receive the acknowledgement[26].

### 3.4 Display Unit:

The collected and processed data may need to be displayed. A LCD is a thin, flat display device made up of any number of color or monochrome pixels arrayed in front of a light source or reflector. It is often utilized in battery-powered electronic devices because it uses very small amounts of electric power[27]. For this purpose an LCD 2×16 shown in Figure 3.15

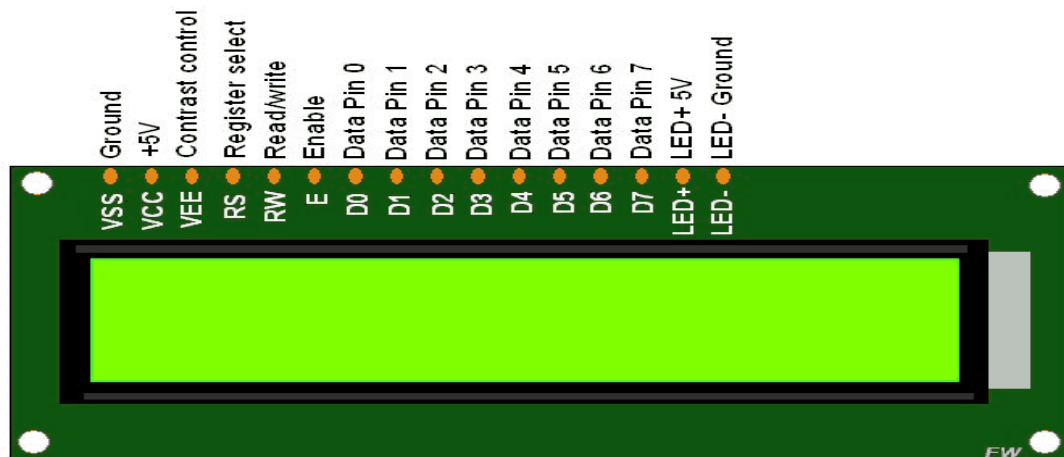

**Figure 3.15:** LCD and Its Pin Out

**Table 3.4:** Technical Specifications of the LCD

Specification	Value
Number of characters	16 characters*2 lines
Module dimension	80.0mm*36.0mm*9.7mm
Area	66.0mm*16.0mm
Active area	56.2mm*11.5mm
Dot size	0.55mm*0.65mm.
Dot pitch	0.60mm*0.70mm.
Character size	2.95mm*5.55mm
Character pitch	3.55mm*5.95mm.
LCD Type	Positive, Reflective, Yellow Green

## **3.5 Monitoring Unit:**

### **3.5.1:ESP8266**

#### **➤ Introduction**

Espressif Systems' Smart Connectivity Platform (ESCP) of high performance wireless SOCs, for mobile platform designers, provides unsurpassed ability to embed Wi-Fi capabilities within other systems, at the lowest cost with the greatest functionality. ESP8266 offers a complete and self-contained Wi-Fi networking solution, allowing it to either host the application or to offload all Wi-Fi networking functions from another application processor. When ESP8266 hosts the application, and when it is the only application processor in the device, it is able to boot up directly from an external flash. It has integrated cache to improve the performance of the system in such applications, and to minimize the memory requirements. Alternately, serving as a Wi-Fi adapter, wireless internet access can be added to any microcontroller-based design with simple connectivity through UART interface or the CPU AHB bridge interface. ESP8266 on-board processing and storage capabilities allow it to be integrated with the sensors and other application specific devices through its GPIOs with minimal development up-front and minimal loading during runtime. With its high degree of on-chip integration, which includes the antenna switch balun, power management converters, it requires minimal external circuitry, and the entire solution, including front-end module, is designed to occupy minimal PCB area. Sophisticated system-level features include fast sleep/wake context switching for energy efficient VoIP, adaptive radio biasing for low-power operation, advance signal processing, and spur cancellation and radio co-existence features for common cellular, Bluetooth, DDR, LVDS, LCD interference mitigation[28].

➤ Features

- 802.11 b/g/n protocol
- Wi-Fi Direct (P2P), soft-AP
- Integrated TCP/IP protocol stack
- Integrated TR switch, balun, LNA, power amplifier and matching network
- Integrated PLL, regulators, and power management units
- +19.5dBm output power in 802.11b mode
- Integrated temperature sensor
- Supports antenna diversity
- Power down leakage current of < 10uA
- Integrated low power 32-bit CPU could be used as application processor
- SDIO 2.0, SPI, UART
- STBC, 1×1 MIMO, 2×1 MIMO
- A-MPDU & A-MSDU aggregation & 0.4μs guard interval
- Wake up and transmit packets in < 2ms
- Standby power consumption of < 1.0mW (DTIM3)

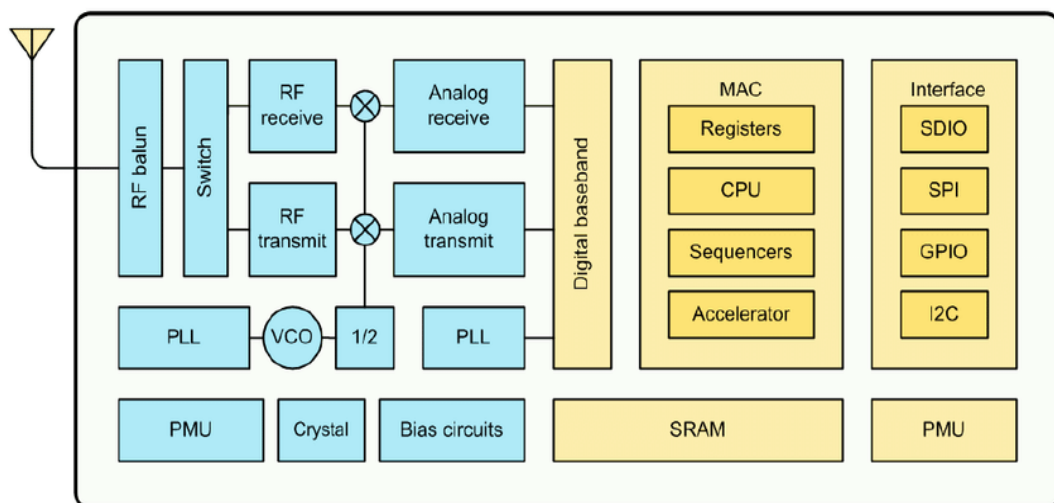

Figure 3.16: ESP8266 Block Diagram



### ➤ **Ultra-Low Power Technology**

ESP8266 has been designed for mobile, wearable electronics and Internet of Things applications with the aim of achieving the lowest power consumption with a combination of several proprietary techniques. The power saving architecture operates in 3 modes: active mode, sleep mode and deep sleep mode. By using advance power management techniques and logic to power-down functions not required and to control switching between sleep and active modes, ESP8266 consumes less than 12uA in sleep mode and less than 1.0mW (DTIM=3) or less than 0.5mW (DTIM=10) to stay connected to the access point. When in sleep mode, only the calibrated real-time clock and watchdog remains active. The real time clock can be programmed to wake up the ESP8266 at any required interval. The ESP8266 can be programmed to wake up when a specified condition is detected. This minimal wake-up time feature of the ESP8266 can be utilized by mobile device SOCs, allowing them to remain in the low-power standby mode until Wi-Fi is needed. In order to satisfy the power demand of mobile and wearable electronics, ESP8266 can be programmed to reduce the output power of the PA to fit various application profiles, by trading off range for power consumption[28].

#### - **Highest Level of Integration**

By integrating the costliest components such as power management unit, TR switch, RF balun, high power PA capable of delivering +25dBm (peak), ESP8266 ensures that the BOM cost is the lowest possible, and ease of integration into any system. With ESP8266, the only external BOM are resistors, capacitors, and crystal [28].

### **3.6 Actuation System:**

An actuator is a piece of equipment that produces movement when given a signal. Actuators are used in the computer control of an environment, industrial automation and in robotics or, more generally, actuators are the machines used for output in control applications. For the situation in a computer controlled greenhouse, the actuators receive their control signal from the microcontroller to control the inside climate variables of the greenhouse. The designed system includes the following actuators:

- A ventilation fan, its speed determines the exchange between inside and outside air, thus causing natural ventilation.
- Heating system consists of a number of heaters distributed along the greenhouse.
- Evaporative cooling system consists of an exhaust fan at one end of the greenhouse and a pump circulating water through and over a cellulose pad installed at the opposite end. When the fan operates, negative pressure is created inside, causing external air to be drawn through the wetted pad. Evaporation results from contact between water and air, getting a lower inside temperature in the greenhouse.
- Irrigation system, water is pumped through polyethylene tubes to apply drip irrigation.
- Artificial lighting lamps, apply light radiation over plants to lengthen the photoperiod [29].

### 3.7 Power Supply

The limitation of the wireless sensor unit can be discussed in term of the power, which is to be considered as crucial in the deployment of the sensor section. The sensor section needs to have low power consumption, and be portable and flexible. To meet these requirements a portable source of power is proposed. Monitoring of the environmental behavior should be done for duration of complete season. Power supply to sensor node is provided with 3.3VDC/220mA. After determine the output voltage and current of all components of the system that supported by the electrical characteristics for them to make a simple linear power supply, use a transformer to step down the 120V AC to a lower voltage needed. Next, send the low voltage AC through a bridge rectifier to make it DC and use filter capacitors that limit the rectifier ripple to a reasonable value. Finally, add a linear regulator with that can handle the required current to regulate the output voltage. In this prototype 9V lithium battery is selected to energizing the Arduino.

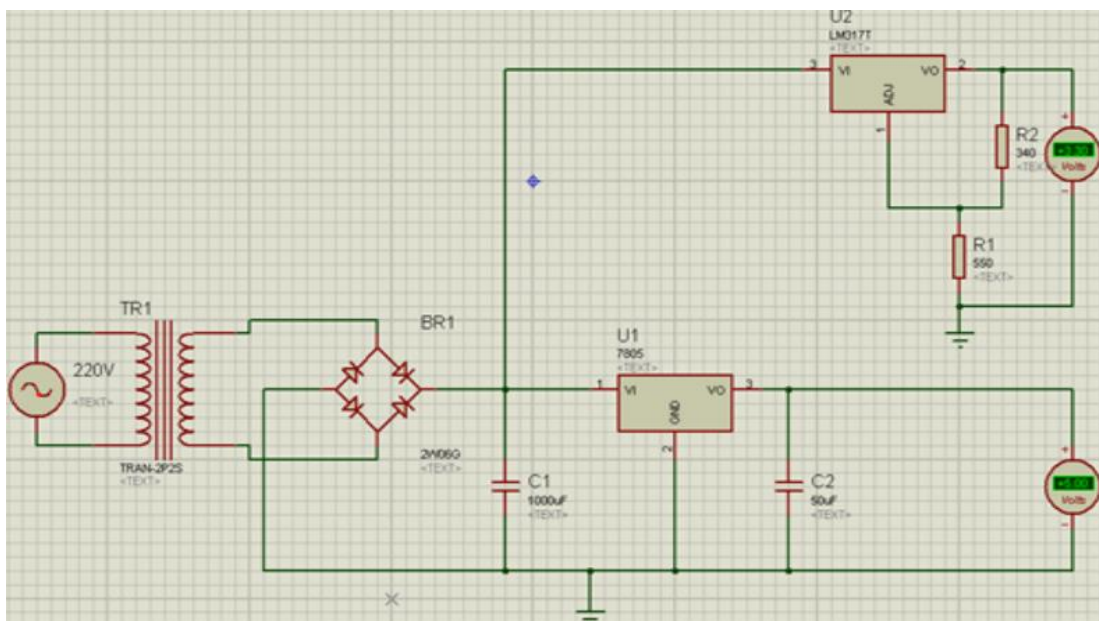

**Figure 3.17:** Design of Power Supply

### 3.8 The Flow Chart

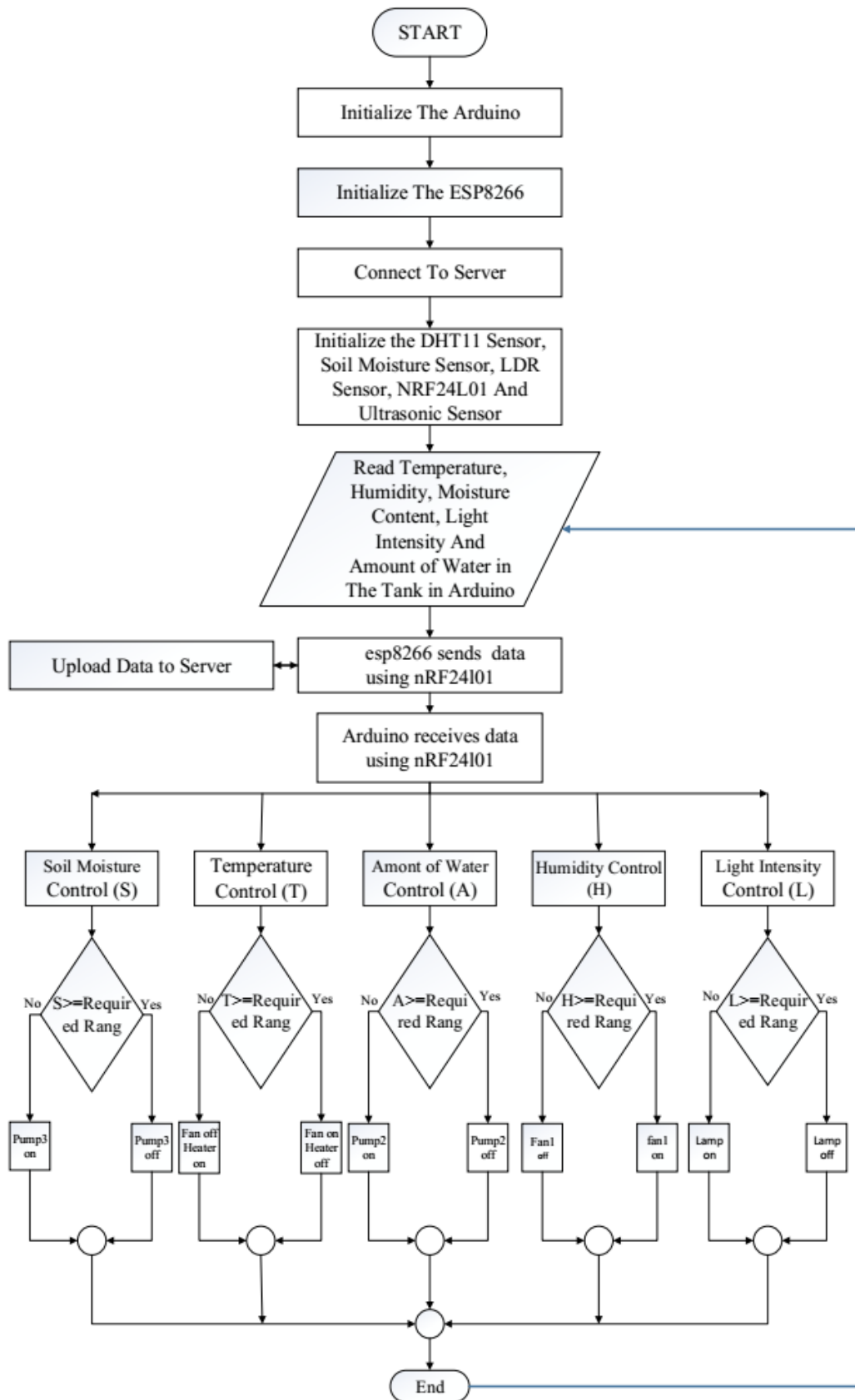

**CHAPTER FOUR**  
**RESULT AND DISCUSSION**



# Chapter Four: Result and Discussion

## 4.1 Introduction

The Design of management system for the Greenhouse consists of Two Units Monitoring unit and control unit.

### 4.1.1 Monitoring unit:

The transmission unit contains several electronic elements: DHT11, Soil Moisture, LDR, Ultrasonic, ESP8266, and Nrf24101 module for transmit; connected as shown in Figure 4.1.

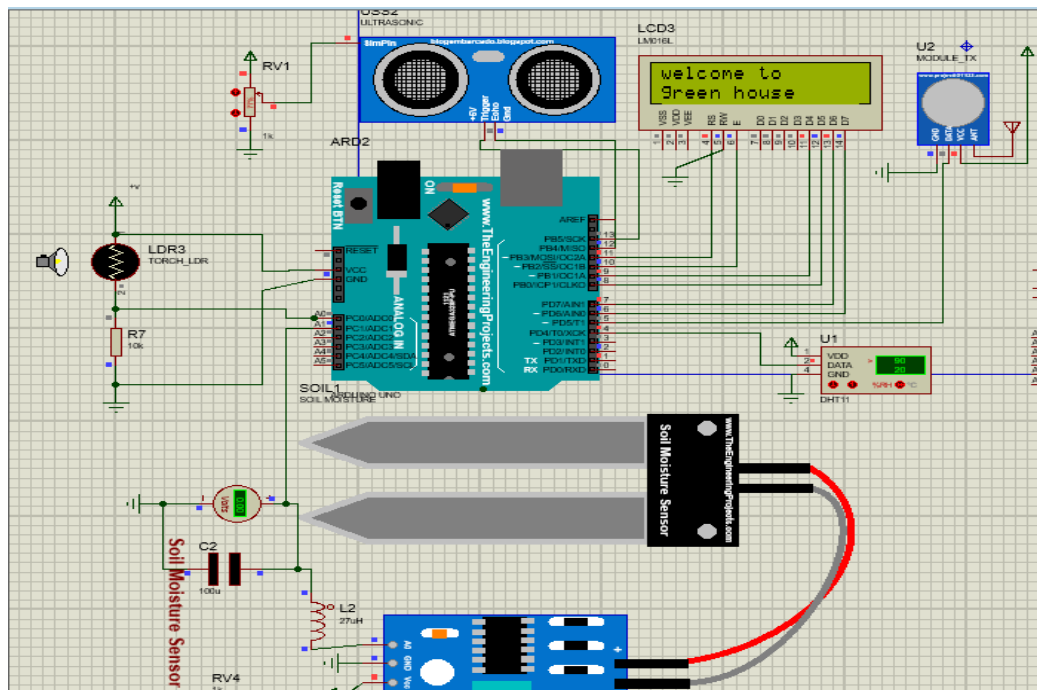

Figure 4.1: Monitoring Unit

The sensors are connected with the ESP8266, where the sensors measure the environmental changes inside the greenhouse such as temperature, humidity, light intensity and soil moisture. The ESP8266 displays the measured values on the LCD screen and then sends the values to the control unit via nRF 24101. Also, ESP8266 uploads the values to the server in order to enable the user to monitor and control the environmental conditions of the greenhouse.

### 4.1.2 Control Unit

The receiving unit connected as shown in Figure 4.2. It contains

Several electronic elements as follows:

- Arduino Uno
- nRF24101
- FAN
- Pump
- Heater
- LED

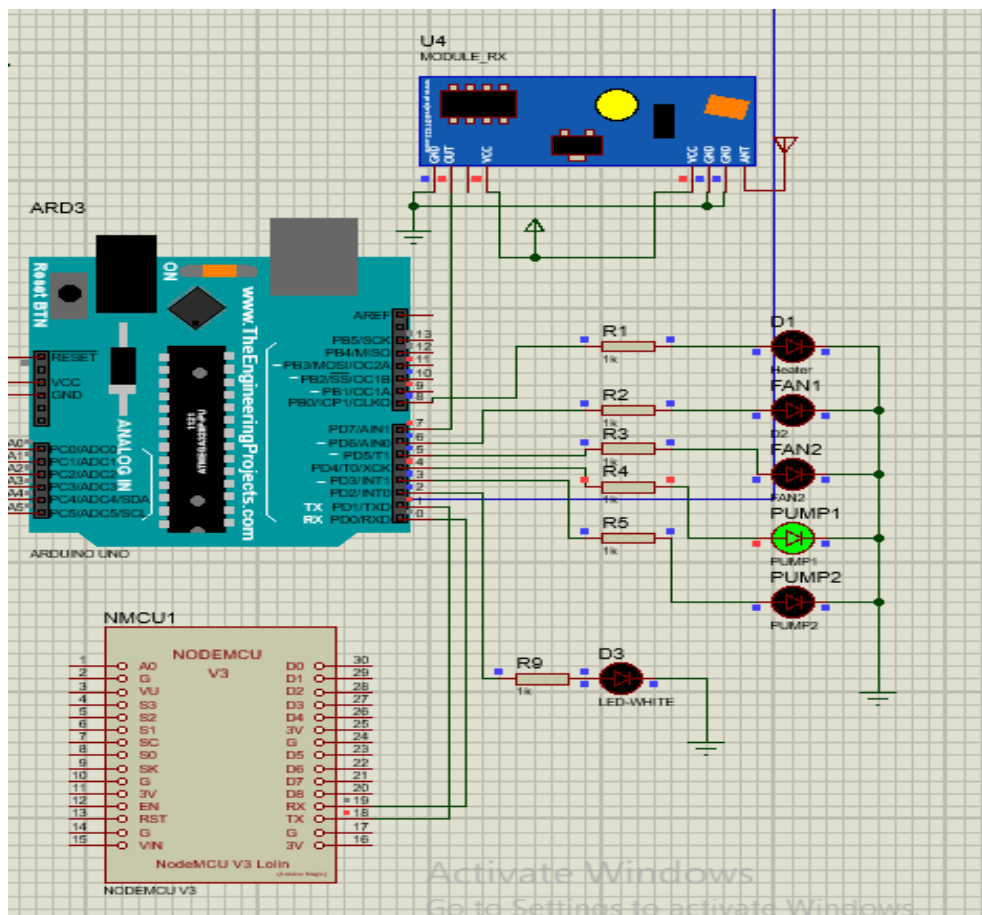

Figure 4.2: Control Unit



- The control unit receives the values generated by the monitoring unit via nRF24l01; where the Arduino uno processes the values by comparing the values that were previously stored in the memory to create the appropriate climatic conditions for the plant through the devices inside the greenhouse such as the pump, heater, fan and LED.
- Four environmental conditions can be maintained: temperature, humidity, light, and level of water in the soil. In the following, the associated response to the change of each parameter can be explored.

#### **4.1.2.1 Temperature Control**

To decrease the acquired temperature in the green house to meet the required one, a ventilating fan can be turned on as in **Figure 4.3**. A continuous tracking to the temperature can be achieved. In addition, while the acquired temperature in the green house was decreasing comparable to the set one, a heater can be turned on as shown in **Figure 4.4**.

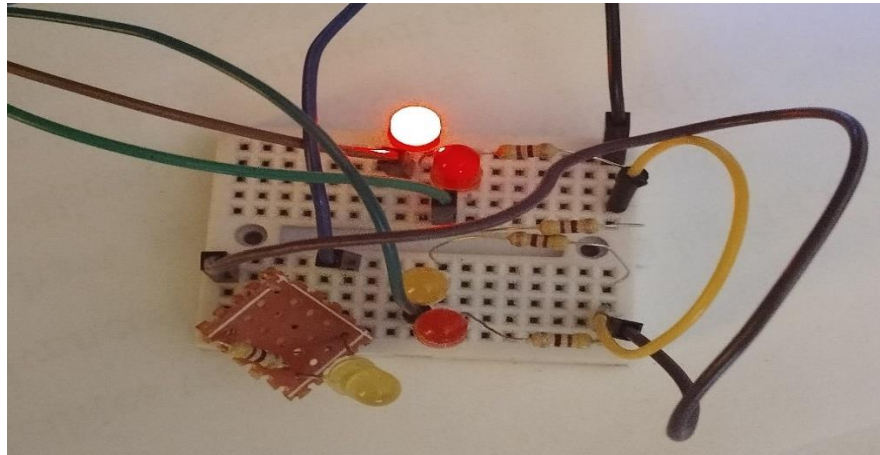
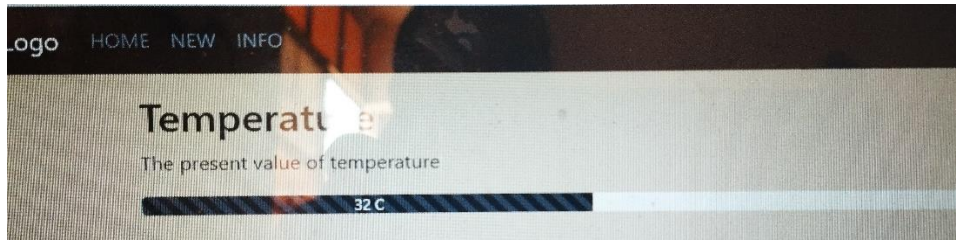

**Figure 4.3:** The Decreasing Temperature

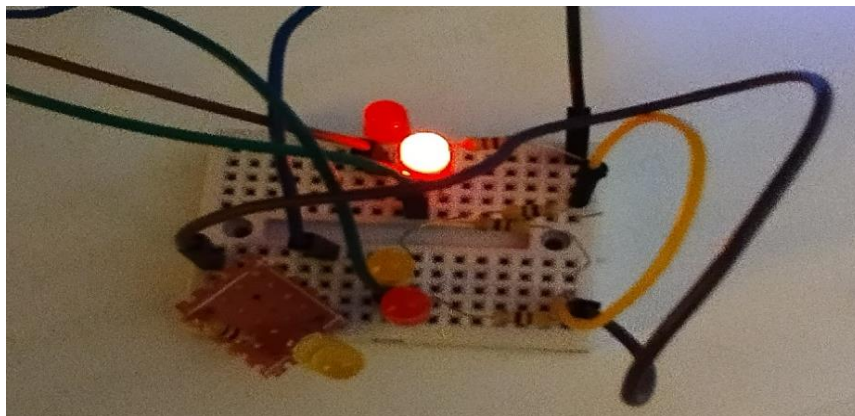
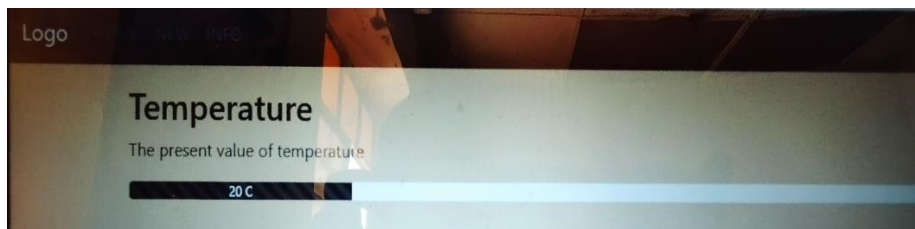
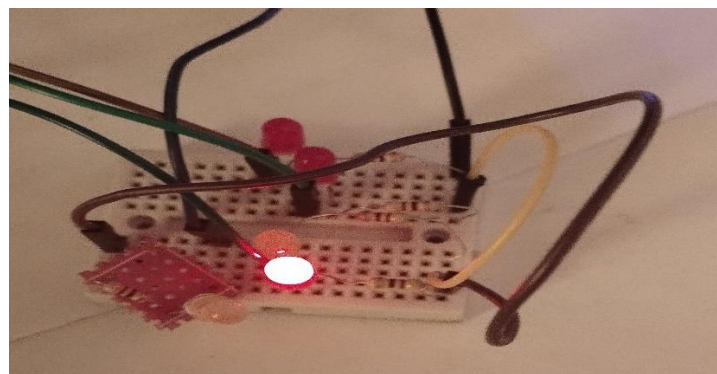
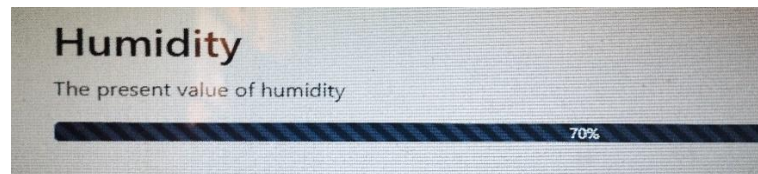

**Figure 4.4:** The Increasing Temperature

#### **4.1.2.2 Humidity Control**

The DHT 11 humidity sensor can track the percentage of the humidity at the green house atmosphere. When the humidity recorded a higher percentage than the set one, the sucker fan can be turned on to

evacuate the excessive percentage of humidity as shown in **Figure 4.5**. While the humidity shows decrement percentage, the heater can be turned on to inject vapeded water to the environment of the green house as can be shown in **Figure 4.6**.



**Figure 4.5:** The Decreasing Humidity

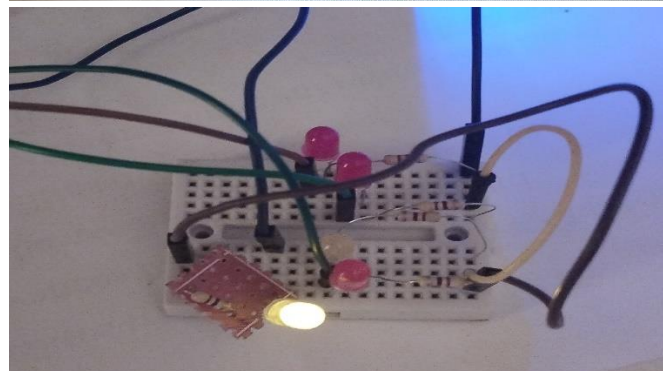
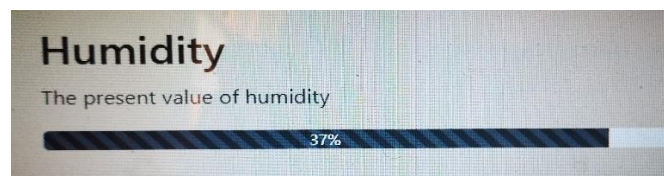

**Figure 4.6:** The Increasing Humidity

### 4.1.2.3 Light Control

Most of the crop needs a natural sun light to grow. The green house can provide this direct sun light through its transparent roof. After while this transparent roof become darker by the accumulated dust, therefore the light intensity sensor can be used to monitor and note when the received light is less than the required amount. A lamp can be recognized to indicate the low light intensity inside the greenhouse as shown in, Figure 4.7 and Figure 4.8 to show the statues of light.

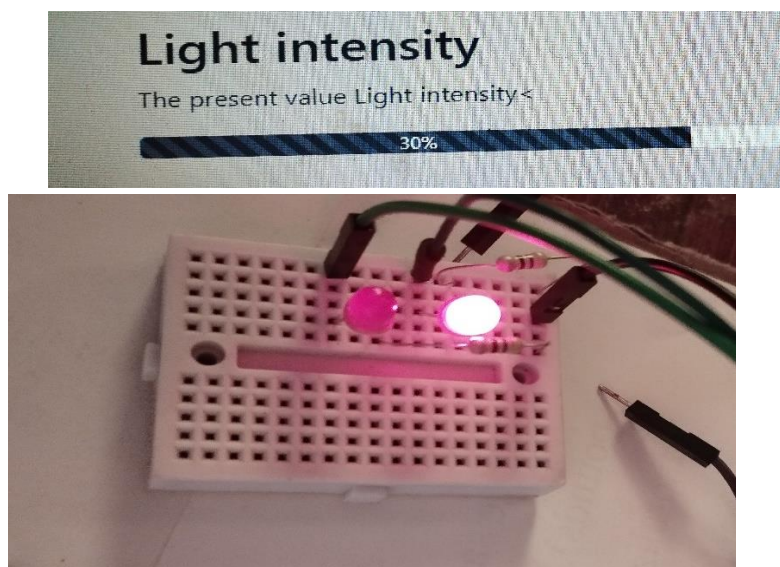

**Figure 4.7:** The Increasing Light

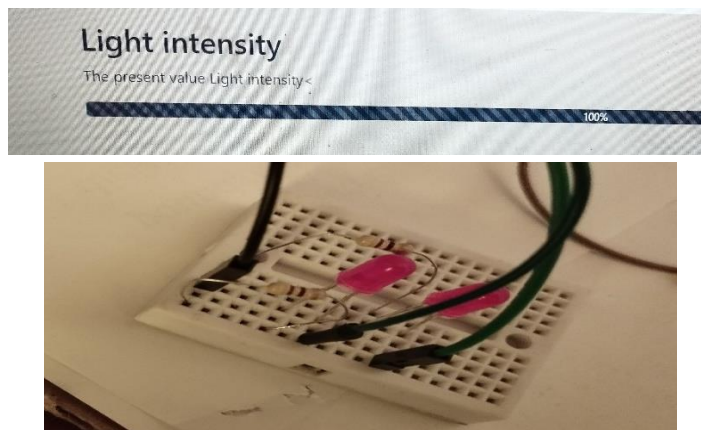

**Figure 4.8:** The Decreasing Light

#### 4.1.2.4 Soil Control

The Soil moisture sensor track the level of water in soil. While the level of water shows decrement percentage, the valve open as can be shown in Figure 4.9. In contrast, when the water level recorded a higher percentage than the set one, the valve closed as shown in Figure 4.10.

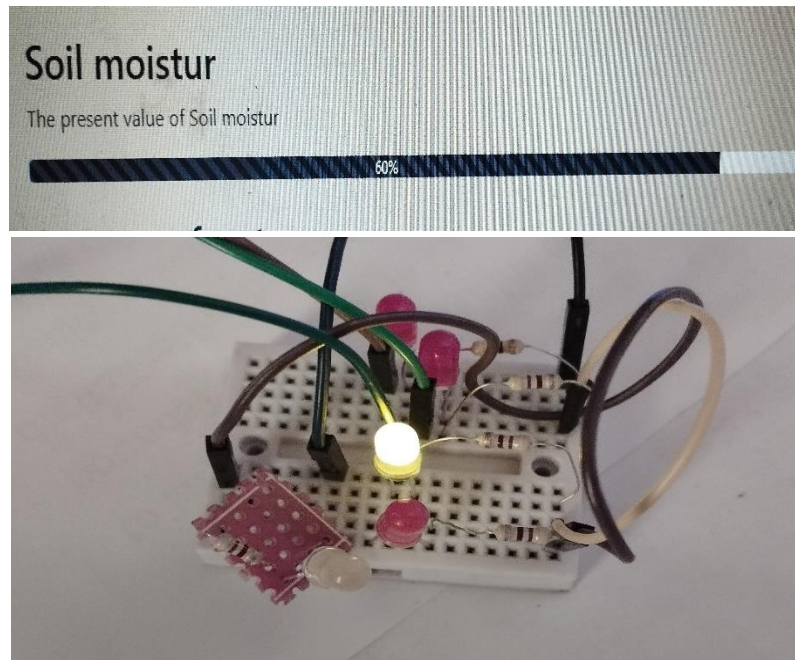

**Figure 4.9:** The Increasing water



**Figure 4.10:** The Decreasing water

#### 4.1.2.5 Amount of Water in the Tank

Ultrasonic Sensor track the amount of water in the tank. While the level of water shows decrement level, the valve open as can be shown in Figure 4.11. In contrast, when the water level recorded a higher level than the set one, the valve closed as shown in Figure 4.12.

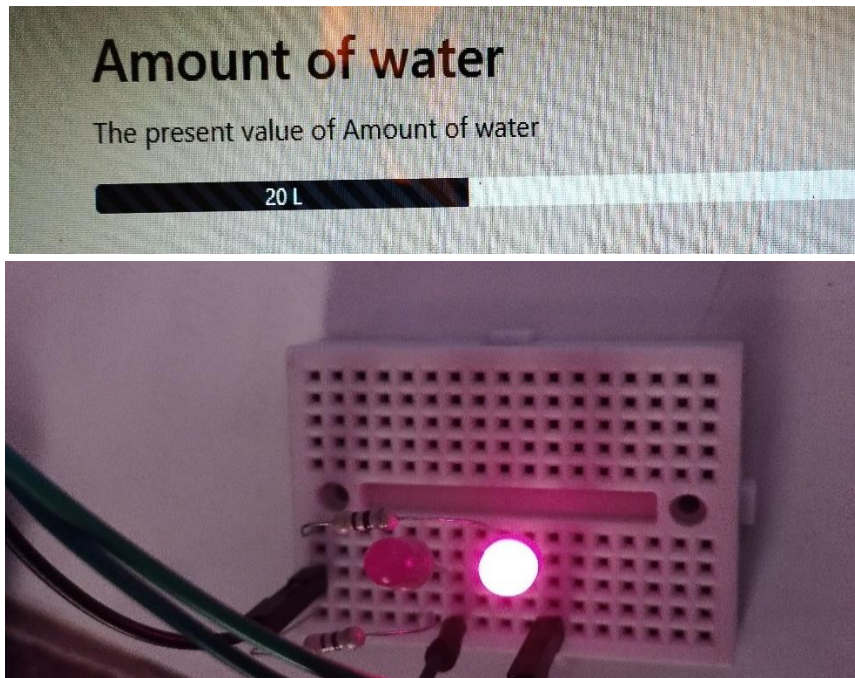

**Figure 4.11:** The Increasing level of water

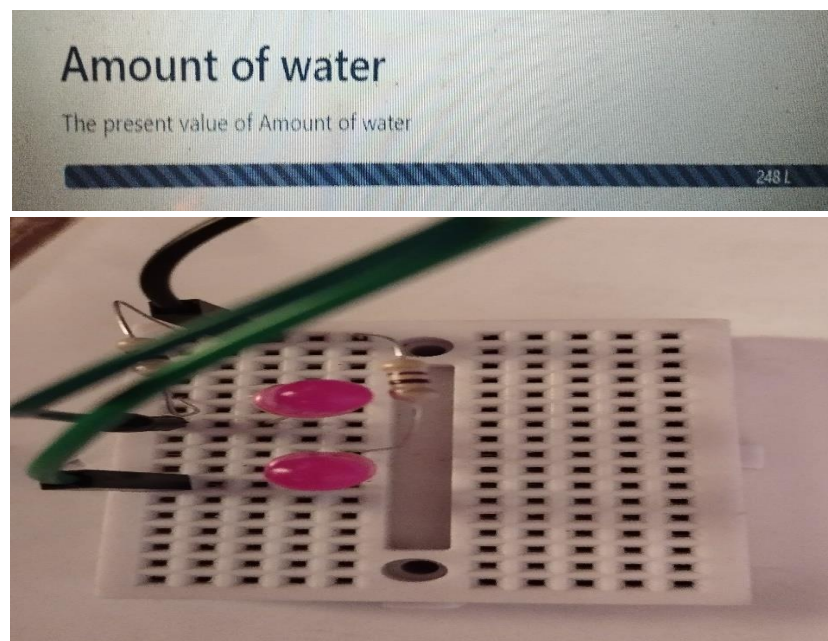

**Figure 4.12:** The Decreasing level of the Water

Logo HOME NEW INFO

### Temperature

The present value of temperature

32 C

### Humidity

The present value of humidity

37%

### Soil moistur

The present value of Soil moistur

72%

### Amount of water

The present value of Amount of water

248 L

### Light intensity

The present value Light intensity <

218%

### control unit

manual

pump1	pump2	heater1	heater2	fan1	fan2	light
<input type="button" value="on"/>	<input type="button" value="on"/>	<input type="button" value="on"/>	<input type="button" value="on"/>	<input type="button" value="on"/>	<input type="button" value="on"/>	<input type="button" value="on"/>
<input type="button" value="off"/>	<input type="button" value="off"/>	<input type="button" value="off"/>	<input type="button" value="off"/>	<input type="button" value="off"/>	<input type="button" value="off"/>	<input type="button" value="off"/>

automation

### plants

choose the plants you want to grow on the farm:

Activate Windows  
Go to Settings to activate Windows.

Figure 4.13: Website page

## **CHAPTER FIVE**

### **CONCLUSION AND RECOMMENDATIONS**



## **Chapter Five: Conclusion and Recommendations**

### **5.1 Conclusion**

This thesis presents a simple, low cost, and flexible management design for a greenhouse system using Arduino, esp8266, nRF24l01 and IoT technology.

Temperature, humidity, light, soil moisture and dimensional sensors are integrated with the monitoring unit; fan, heater, LED and pump with the control unit.

The system has been successfully designed and has the ability to wirelessly transmit and receive data, calculate environmental factors and control the greenhouse to provide the required environment for plant cultivation. A server was set up on the ESP8266 to raise sensors values and display them on the Internet. This system Designed to reduce time and human efforts to manage the greenhouse.

### **5.2 Recommendations**

- The usage of electricity for Greenhouse can be reduced by using solar system specially the agricultural area are far from supply.
- Monitoring the growth rate and early detection of diseases.
- In case of abnormal conditions warning messaged send to mobile phone, email through esp8266.
- More sensors can be added to the sensing unit to monitor other environmental parameters such as soil pH level, air flow, carbon monoxide and oxygen level.

## REFERENCES

1. Li, L.-l., et al. *The greenhouse environment monitoring system based on wireless sensor network technology*. in *2011 IEEE international conference on cyber technology in automation, control, and intelligent systems*. 2011. IEEE.
2. Castilla, N. and J.J.J.o.h.s. Lopez-Galvez, *Vegetable crop responses in improved low-cost plastic greenhouses*. 1994. **69**(5): p. 915-921.
3. Both, A.J.N.J., USA. Retrieved from pdf, *Greenhouse temperature management*. 2008.
4. Hopkins, W.G., *Plant development*. 2006: Infobase Publishing.
5. Chaudhary, D., et al., *Application of wireless sensor networks for greenhouse parameter control in precision agriculture*. 2011. **3**(1): p. 140-149.
6. Rodríguez, C., et al., *Diurnal greenhouse temperature control with predictive control and online constrains mapping*. 2010. **43**(1): p. 140-145.
7. Urban, G., *Jacob Fraden: Handbook of modern sensors: physics, designs, and applications*. 2016, Springer.
8. Mosenia, A. and N.K.J.I.T.o.e.t.i.c. Jha, *A comprehensive study of security of internet-of-things*. 2016. **5**(4): p. 586-602.
9. Lavanya, M., S.J.I.J.o.E. Srinivasan, and Technology, *A survey on agriculture and greenhouse monitoring using IOT and WSN*. 2018. **7**(2.33): p. 673-677.
10. Reddy, S.J.I.J.o.C.A., *Design of remote monitoring and control system with automatic irrigation system using GSM-bluetooth*. 2012. **47**(12).

11. Thomas, D.B.A., S.J.I.J.o.E. Michahial, and I.T. Volume, *Shreeraksha. P, Vijayashri B Nagvi, Suresh M," Industry Based Automatic Robotic Arm.* 2013. **2**.
12. Olawale, J., et al. *Development of a microcontroller based robotic arm.* in *Proceedings of the 2007 Computer Science and IT Education Conference.* 2007. Citeseer.
13. Simon, M., *Arduino projects for the evil genius.* United States of America: McGraw-Hill Education.
14. Othman, M.F. and K.J.P.E. Shazali, *Wireless sensor network applications: A study in environment monitoring system.* 2012. **41**: p. 1204-1210.
15. Berezowski, K.S.J.I.J.o.W. and M. Networks, *The landscape of wireless sensing in greenhouse monitoring and control.* 2012. **4**(4): p. 141.
16. Bansal, K., D.J.G.J.o.P. Saini, and A. Mathematics, *Optimizing the Coordinates Position for Optimal Placement of ZigBee for Power Monitoring From Remote Location.* 2016. **12**(1): p. 11-17.
17. Sahu, K., S.G.J.I.J.o.S. Mazumdar, and E. Research, *Digitally greenhouse monitoring and controlling of system based on embedded system.* 2012. **3**(1): p. 41-48.
18. IDRISS, A.I.A., S.A.A. ALI, and S.M.A. ALSADIG, *CONTROLLING AND MONITORING GREEN HOUSE USING MICROCONROLLER ARDUINO MAGA BEASE SYSTEM.* 2016, Sudan University of Science & Technology.
19. Nikhade, R.K. and S.J.I.J.o.A.C.R. Nalbalwar, *Monitoring greenhouse using wireless sensor network.* 2013. **3**(2): p. 79.
20. Gao, L., M. Cheng, and J.J.T.I.J.o.E.E. Tang, *A wireless greenhouse monitoring system based on solar energy.* 2013. **11**(9): p. 5448-5454.

21. Jianjun, Z., et al. *Greenhouse monitoring and control system based on zigbee*. in *Proceedings of the 2nd International Conference on Computer Science and Electronics Engineering (ICCSEE 2013)*. 2013.
22. Humidity, D., *DHT11 Temperature & Humidity Sensor Features a Temperature & Humidity Sensor Complex with a Calibrated Digital Signal Output*, D-Robotics UK, 1-3. 2010.
23. Morgan, E.J., *HC-SR04 ultrasonic sensor*. 2014.
24. Zhang, X., C. Yang, and L. Wang. *Research and application of a new soil moisture sensor*. in *MATEC Web of Conferences*. 2018. EDP Sciences.
25. Badamasi, Y.A. *The working principle of an Arduino*. in *2014 11th international conference on electronics, computer and computation (ICECCO)*. 2014. IEEE.
26. Nordic Semiconductor, A., *nRF24L01 Single Chip 2.4 GHz Radio Transceiver Product Specification*. 2006, Sept.
27. Soni, N., et al., *Distance measurement using ultrasonic sensor and arduino*. 2017. **7**(3): p. 1-2.
28. Marian, P.J.E.S., " *ESPRESSIF SMART CONNECTIVITY PLATFORM: ESP8266*. 2013. **12**.
29. Al-Adwan, I., M.S.J.I.J.o.E. Al-D, and A. Technology, *The use of zigbee wireless network for monitoring and controlling greenhouse climate*. 2012. **2**(1): p. 35-39.