



**Sudan University of  
Science and Technology  
College of Engineering  
Electronics Engineering  
Department**



# **Evaluation for Quality of Service in 5G Networks Using SDN**

**تقييم جودة الخدمة في شبكات الجيل الخامس باستخدام SDN**

**A Research Submitted In Partial fulfillment for the  
Requirements of the Degree of B.Sc. (Honors) in  
Electronics Engineering**

**Prepared By:**

- 1- Asmaa Altom Dauod Abushanab
- 2- Mozdalifa Awad Alla Elkheir
- 3- Nahla Mohammed Khaleel
- 4- Rimas Hassan Mohammed Alzebair

**Supervisor by:**

Dr. Ibrahim Khider Eltahir

**March 2022**

## الاية:

قال تعالى:

”قُلْ لَوْ كَانَ الْبَحْرُ مَدَادًا لَكَلِمَاتِ رَبِّي لَنَفَذَ الْبَحْرُ قَبْلَ أَنْ تَنْفَذَ كَلِمَاتُ رَبِّي وَلَوْ جِئْنَا بِمِثْلِهِ  
مَدَدًا \* قُلْ إِنَّمَا أَنَا بَشَرٌ مِثْلُكُمْ يُوحَىٰ إِلَيَّ أَنَّمَا إِلَهُكُمُ اللَّهُ وَاحِدٌ فَمَنْ كَانَ يَرْجُوا لِقَاءَ رَبِّهِ  
فَلْيَعْمَلْ عَمَلًا صَالِحًا وَلَا يُشْرِكْ بِعِبَادَةِ رَبِّهِ أَحَدًا \*”

الكهف الآية (110)

## الإهداء:

الى الذي اوصاني به الله برا واحسانا الى من علمني كل امور الحياه على حساب جهده وطاقته

ابي العزيز,,

الى التي انارت دربي بدعائها الى نبع الحب والحنان وشمعه العطاء

امي الغالية,,

الى من وقفو معي دائما سندي في الحياه

اخوتي واخواتي,,

والى اعز اصدقائي والى اخي وصديقي ورفيق عمري

والشكر كل الشكر الى اساتذتي واصدقائي الذين وقفو معي خلال هذه الرحله الطويله من النجاح.

## **ACNOWLEDGMENT**

Everything happens with the grace of God, so we thank the almighty god for providing us and opportunity, strength and ambience to successfully accomplish this project. Our sincere thanks are due to our supervisor

Dr. Ibrahim Elkhider Here are the most beautiful wishes for health, wellness, and a bright future, and words of thanks stemming from the heart with all love and sincerity

## **Abstract**

Confidence in the quality of modern communications networks plays an important role as a driver of the technological and market success of any communications technology or service. Most technological approaches to this problem focus only on network security and do not include an aspect such as quality of service (QoS), which also plays an important role in the formation of trust, both on the part of consumers and on the part of the regulator. Whereas trust in 5G networks lies in the areas of formation of quality-of-service requirements managing and defining its requirements. One of the techniques used to improve the quality of service in 5G networks was applied in this work, namely (SDN), and MATLAB was chosen as a simulation environment for this technology to ensure a large volume of data with little delay and large bandwidth with high productivity, which was observed in the results.

## المستخلص:

تلعب الثقة في جودة شبكات الاتصالات الحديثة دورا مهما كمحرك للنجاح التكنولوجي والتسويق لأي تقنية او خدمة اتصالات. وتركز معظم الاساليب التكنولوجية لهذه المشكلة فقط علي امان الشبكة ولا تتضمن جانبا مثل جودة الخدمة، التي تلعب دورا مهما في تكوين الثقة، سواء من جانب المستهلكين او من جانب المنظم. حيث تكمن الثقة في شبكات الجيل الخامس في مجالات تشكيل متطلبات جودة الخدمة وادارتها وتحديد متطلباتها، في هذا العمل تم تطبيق احد التقنيات المستخدمة للتحسين من جودة الخدمة في شبكات الجيل الخامس (الشبكات من البيانات بتأخير المعرفة بالبرمجيات) وتم اختيار الماتلاب كبيئه محاكاة لضمان حجم كبير قليل وعرض نطاق كبير مع انتاجية عاليه والتي تمت ملاحظتها في النتائج.

## Contents

ACNOWLEDGMENT:.....	III
Abstract: .....	IV
:المستخلص.....	V
ChapterOne: Introduction:.....	1
1.1Preface: .....	1
1.2Problem statement:.....	2
1.3Propose solutions: .....	2
1.4Thesis objective: .....	2
1.5Methodology:.....	2
1.6thesis outline:.....	2
ChapterTwo: <a href="#">LiteratureReview</a> .....	4
2.1:Background: .....	4
2.2:Related Work .....	5
2.2.1:QOS Flows: .....	7
2.2.2:QOS Profile: .....	8
Chapter Three : Methodology.....	17
3-1:MATERIALS AND METHODS:.....	17
3-2:Performancemetrics:.....	18
Chapter Four: Simulation and Results .....	20
4-1:simulation description:.....	20
4-2:Results and Discussion: .....	21
Chapter Five : Conclusion and Recommendation.....	26
5-1Conclusion:.....	26
5-2:Recommendation .....	27
References:.....	28

## List of Figure

Figure 2.1: QOS Flowin 4G and 5G.....	7
Figure 2.2 : QOS Flows Mapping in 5G.....	8
Figure 2.3: QOS Requirement .....	10
Figure 2.4: Coexistence of URLLC and EMBB.BS, basestation .....	13
Figure 4.1: Avirtual network without SDN .....	21
Figure 4.2: Avirtual network with SDN.....	22
Figure 4.3: comparing delay with SDN and without SDN .....	23
Figure 4.4: comparing throughput with SDN and without it .....	24
Figure 4.5: bandwidth with SDN and without it .....	25

## List of Abbreviations

ARP	Allocation and Retention Priority
CDMA	code division multiple access
CPE	customer premiers equipment
DRB	data radio bearer
E-RAB	evolved packet switched system bearer – radio access bearer
EMMB	enhanced mobile broadband
EPS	Evolved packet system,
E2E	end to end
EPS	evolved packet switch system bearer
GBR	guaranteed bite-rate
GFBR	Guaranteed flow bite rate
GNB	G node B
GSM	Global system for mobile
IOT	internet of thing's,
IPTV	Internet protocol television
ITU	International Telecommunications Union



LTE	long term Evaluation
MCC	mobile cloud computing
MFBR	Maximum flow bite rate
MMTC	massive machine type communication
MNs	mobile nodes,
MPLS	multiprotocol label switching,
M2M	machine to machine,
NFV	Network function virtualization
NGN	next generation network
PDN	packet data network
PDP	programmed data processor
PDR	packet detection rules
PDU	packet data unit
QFI	QOS flow ID
QOE	Quality of Experience,
QOS	Quality Of Service
RAN	Radio access network
RQA	reflective QOS attribute
RQI	reflective QOS indicator
SDN	Software define Network
SGSN	serving GPRS support node
SMF	session management function
UE	user equipment
UPF	user plane function
URLLC	ultra-reliable low latency communication
UMTS	Universal Mobile Telecommunications System
VOIP	voice over Internet protocol
5QI	5G QOS identifier
3GPP	third generation partnership project



# CHAPTER ONE

## INTRODUCTION

### 1.1 Preface

Network operators generally accommodate high quality of service applications by providing more network resources to ensure the required service and performance taking in to account peak requirements. this process it becomes complex and more difficult with the development of a large number of new applications and service with strict performance requirements. to meet such a challenge efficiently the fifth generation was introduced.

It has promised to provide reliable services at ultra-high speed with very low latency.5G will deliver both fixed as well as mobile broadband services anywhere to anyone at any time.

In order to enhance the potential of 5G, Software Defined Network (SDN) is introduced to achieve flexibility in the resource allocation process, allows an operator with an SDN-enabled transmission network to allocate network resources efficiently develop users' demands and adjust resource allocation and network optimization use while ensuring the provision of high quality of service and bandwidth instability.

## **1.2 Problem Statement**

5G networks bring many new technologies and challenge to wireless networks. Now multiple standards organizations require 5G mobile network to deliver traffic-based quality of service (QOS), which is key to operators recovering the large costs of 5G upgrades, because data traffic is the most profitable part of their business.

- High latency.
- Low throughput.
- Low Bandwidth.

## **1.3 Proposed Solutions**

Use software defined network (SDN) to improve data rate, throughput, Bandwidth, and delay.

## **1.4 Research Objective**

The objectives of this thesis are

- To decrease delay.
- To increase throughput.
- To increase bandwidth.

## **1.5 Methodology**

Designing a different topology of 5G Network, Evaluating the QOS to This Network and Evaluating the QOS after Appling SDN Using MATLAB.

## **1.6 thesis outline**

The rest of this thesis include the following chapters

Chapter (2) presents the background

Chapter (3) shows the methodology

Chapter (4) presents the simulation and results

Chapter (5) describes the conclusion and recommendation.

# CHAPTER TWO

## LITERATURE REVIEW

### 2.1 Background

In 1G networks and 2G networks such as GSM and CDMA there was only one aspect of QOS and it is voice. Providing quality speech was the major concern.

Third-generation (3G) wireless systems, new QOS requirements are imposed on the networks. For example, with interactive video conferencing or streaming video and audio, the network must be able to deliver these services to the destination on a timely basis. Because flow control or retransmission is not possible for these applications, the bit error rate or packet loss ratio must be kept below a certain level; otherwise, the QOS may suffer. For instance, if the bit error rate is too high, the video in an MPEG application may never synchronize at a receiver

Quality of Service (QOS) has become an important part of network planning & design when deploying 4G/LTE broadband wireless for data & voice services. There are subscribers who use LTE services for critical operations (e.g., voice calls, bank transactions, hospital operations), and there are subscribers who just want to enjoy premium Internet & applications experiences

LTE was designed to meet these increased data and application demands with reliable connections and low cost of deployment. A best-case scenario would feature a highly flexible QOS framework that is built to withstand future challenges. Advanced LTE QOS defines priorities for certain customers or services during congestion. In LTE Broadband Network QOS is implemented between CPE and PDN

Gateway and is applied to a set of bearers. 'Bearer' is basically a virtual concept and is a set of network configuration to provide special treatment to set of traffic.

## **2.2 Related Work**

Quality of Service (QoS) Next Generation Networks (NGN) consists of support functionalities for data transport, and control transport, as well as functionalities for support of services and applications. The measurement of traffic is a basic control activity in order to provide Quality of Service, in addition 5G communication system is designed by the finest Quality of Service (QoS). Quality of Service (QoS) refers to a network's ability to achieve maximum bandwidth and deal with other network performance elements like latency, error rate and uptime. Quality of service also involves controlling and managing network resources by setting priorities for specific types of data (video, audio, files) on the network. QoS is exclusively applied to network traffic generated for video on demand, IPTV, VoIP, streaming media, videoconferencing and online gaming. The primary goal of quality of service is to provide priority to networks, including dedicated bandwidth, controlled jitter, low latency and improved loss characteristics. Its technologies supply the elemental building blocks that will be used for future business applications in campus, wide area networks and service provider networks. [1]

5G promises a range of capabilities from high throughput to supporting real-time low latency factory automation or self-driving cars. This range of capabilities requires that the Quality of Service (QoS) characteristics, such as delay, error rate, and priority be specified and enforced. In LTE the Quality of Service (QoS) is enabled and it is based

on bearers. In order to better understand the enhancements introduced in 5G, a comparison with legacy mobile generation is necessary. EPS bearer/E-RAB established when UE connects to a PDN is called the default bearer, while any additional bearer is referred to as a dedicated bearer. Each bearer is characterized by the same packet forwarding treatment (e.g., scheduling policy, queue management policy, rate shaping policy, RLC configuration, etc.). A bearer is called guaranteed bit-rate (GBR) bearer if it is provided dedicated network resources, otherwise, it is called non-GBR bearer. Unlike LTE, where QOS model is based on Radio Bearers, in 5G it is flow based. Furthermore, in LTE there is a strict one-to-one mapping between Evolved Packet Switched System Bearers (EPS-bearers) and EPS radio access bearers (E-RAB). Whereas, in 5G it is possible to map several QOS Flows to one Data Radio Bearer (DRB).

Network slicing provides a holistic end-to-end virtual network for a given tenant. Whereas, QOS model makes possible the differentiation of traffic coming from the same UE. Therefore, Network Slicing differentiates from QOS because it will enable end-to-end virtual networks encompassing compute, storage and networking functions. Contrarily, QOS cannot discriminate and differently treat the same type of traffic (e.g., VoIP traffic) coming from different tenants or perform traffic isolation. It is thought that Network Slicing in conjunction with QOS model will provide better service and improve user experience. First will describe the QOS Flows, QOS Profile and the QOS Parameters in 5G. Then, it contains the rules for mapping the QOS Flows in Uplink and Downlink direction. Concluding with the impact of QOS method on RAN interfaces.



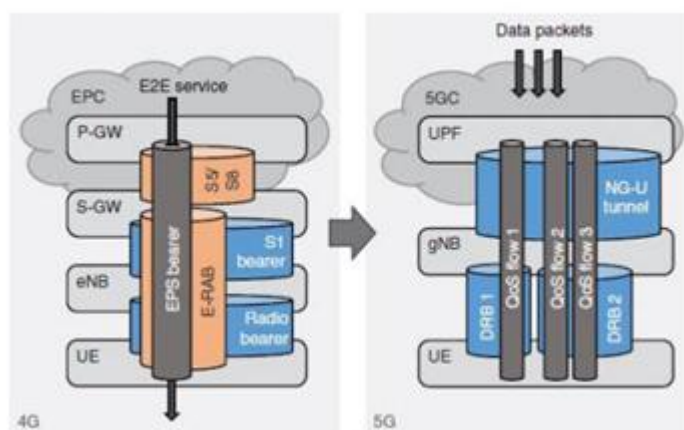

Figure 2.1 QoS Flow in 4G and 5G

### 2.2.1 QoS Flows

3GPP has defined the QoS Flow as the finest granularity of QoS differentiation in the PDU Session. QoS Flows are identified by a QoS Flow ID (QFI) in the network which shall be unique within a Packet Data

Unit (PDU) Session and is carried in an encapsulation header on N3 tunnel (UPF-GNB Interface). On 5G, one QoS Flow can be mapped to one or more Data Radio Bearers (DRBs) that have the same QoS requirements.

UL/DL Packet Detection Rules (PDRs) contains packet filters required by User Plane Function (UPF) to map and mark the packets into QoS Flows in UL and DL direction. These rules are provided from Session Management Function (SMF) to User Plane Function (UPF) once the QoS Flow is enabled. One QoS Flow has associated with it also another identifier, 5G QoS Identifier (5QI) which is included in the QoS Profile and is linked with the QoS Parameters for the Physical Layer. 5G QoS Identifier (5QI) parameter can be selected from the standardized or dynamically assigned value. QoS Flows are categorized

in three main groups: Guaranteed Bit Rate (GBR), non-Guaranteed Bit Rate (Non-GBR) and Delay Critical QoS Flow. Each category has specific QoS Parameters to be assigned based on the requirements for physical layer performance, e.g., Guaranteed Bit Rate (GBR) QoS Flows have a QoS Parameter that signals the minimum bit rate to be ensured by the network. 3GPP has provided the list of standardizes QFI.

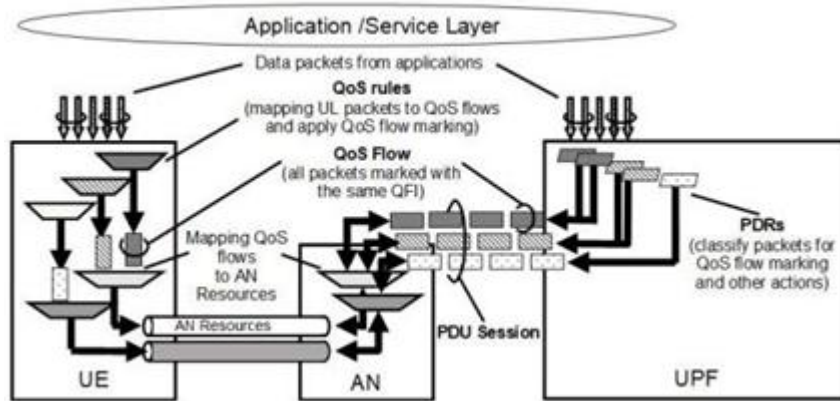

(Figure2.2): QoS Flows Mapping in 5G

### 2.2.2 QoS Profile

contains the parameters that determine the QoS flow type as: GBR, non GBR or Delay Critical. QoS Parameters signalled for a QoS Flow are the following:

- 5G QoS Identifier (5QI) is a scalar that is used as a reference to 5G QoS characteristics for controlling QoS forwarding treatment for the QoS Flow. 5QI value may be assigned dynamically or from standardized set of values. Standardized 5QI values are specified for services that are assumed to be frequently used and thus benefit from optimized signalling by using standardized QoS characteristics. Dynamically assigned 5QI values (which require a signalling of QoS characteristics as part of the QoS profile) can be used for services for which standardized 5QI values are not defined.

- Allocation and Retention Priority (ARP) contains information about the priority level, the pre-emption capability and the pre-emption vulnerability.

The ARP Priority parameters defines the priority level of allocated resources per each flow. Therefore, admission control can be performed for GBR Flows). Furthermore, it may use to select which existing QOS Flow to pre-empt during resource limitations. ARP value for each QOS Flow is selected and signalled by SMF.

- Reflective QOS Attribute (RQA) is an optional parameter applied only for non GBR Flows. It indicates that certain traffic carried on this QOS Flow is subject to Reflective QOS mapping. It is used at UE side to map the UL traffic into QOS Flows. When RQA is enabled for a QOS Flow, reflective QOS Indicator (RQI) is signalled by NG-RAN.

- Guaranteed Flow Bit Rate (GFBR) is a parameter set only for GBR flows and shall be defined for both directions, UL and DL. Denotes the bit rate that is guaranteed to be provided by the network to the QOS Flow over the Averaging Time Window.

- Maximum Flow Bit Rate (MFBR) is a parameter configured only for GBR flows and shall be defined for both directions, UL and DL. Limits the bit rate to the highest bit rate that is expected by the QOS Flow.[2]

New 5G applications are foreseen to facilitate domains such as M2M, health (e.g., e-health, telemedicine) and education sector. Different 5G applications will need different requirements for their performance. New ways with enhanced capacity (e.g., small cells deployment), intelligent traffic and offload schemes will have to be developed and implemented in order to meet these performance requirements. Moreover, the complexity.

and high degree of heterogeneity towards 5G also impose the requirements for autonomous network management. Although there are no detailed specifications and general requirements of 5G, exploring 5G requirements (e.g., from users & network perspective) as shown in (Figure 2-3) that define user's satisfaction in the delivered services is of crucial importance.[3]



(Figure2-3) QOS Requirement

the future 5G systems should require smarter devices able to provide mobile broadband services to the end users, ubiquitous mobility, advanced mobile cloud computing (MCC) features, fog computing features, enormous processing power of the mobile devices, machine-to-machine-based communications, better network utilization, and many other advanced capabilities. Above all, the key goal is provisioning high Quality of Service (QOS) support, as well as faster computing features and longer battery life of mobile nodes (MNs). The exponential growth in the amount of traffic carried through mobile networks and cloud

computing is followed by a novel research work towards the advanced computing capabilities of the core part of the networks.

The key trend in the past decade was to push the computing, control, data storage, and processing in the cloud computing. However, in order to meet the intelligent networking and computing demands in 5G network, the cloud alone encounters too many limitations, such as requirements for reduced latency, high mobility, high scalability, and real-time execution. The existing cloud computing mechanisms and data delivery models do not provide the necessary QOS and Quality of Experience (QOE) for the forthcoming large scale and dynamic services in 5G networks. This is because of the large number of hops of wired networks between the 5G base stations and the cloud which leads to a significant increase in latency. Moreover, when all data generated by the devices is directly forwarded to the cloud may devour the bandwidth and lead to congestion. A new paradigm called fog computing has emerged to overcome these limitations. Fog distributes computing, data processing, and networking services to the edge of the network, closer to end users. It is an architecture.[4]

The next generation of 5G networks is being developed to provide services with the highest Quality of Service (QOS) attributes, such as ultra-low latency, ultra-reliable communication, high data rates, and high user mobility experience. To this end, several new settings must be implemented in the mobile network architecture such as the incorporation of Network Function Virtualization (NFV) and Software-Defined Networking (SDN), along with the shift of processes to the edge of the network. This work proposes an architecture combining the NFV and SDN concepts to provide the logic for Quality of Service (QOS) traffic detection and the logic for QOS management in next-generation mobile networks. It can be applied to the mobile backhaul and the mobile

core network to work with both 5G mobile access networks or current 4G access networks, keeping backward compatibility with current mobile devices. In order to manage traffic without QOS and with QOS requirements, this work incorporates Multiprotocol Label Switching (MPLS) in the mobile data plane. A new flexible and programmable method to detect traffic with QOS requirements is also proposed, along with an Evolved Packet System (EPS)-bearer/QOS-flow creation with QOS considering all elements in the path. These goals are achieved by using proactive and reactive path setup methods to route the traffic immediately and simultaneously process it in the search for QOS requirements.[5]

The flexibility and adaptability of 5G are considered its main features enabling the creation of dedicated wireless networks customized for specific applications with a certain level of QOS. The International Telecommunication Union (ITU) identified three distinct services for 5G networks enhanced mobile broadband (EMMB): a service comparable to LTE networks optimized for high throughput; the massive machine type communication (MMTC): a service designed for spanning large IOT networks optimized for a large number of devices with low power consumption; and the ultra-reliable low latency communication (URLLC): a service for safety-critical applications requiring high reliability and low latency. These different services can be realized by slicing the network into distinct independent logical networks which can be offered as a service adhering to customer-specific SLAs, called Network Slice-as-a-Service. A cost-efficient way to realize network slices is the shared use of network resources among customers, e.g., virtualization techniques used on off-the-shelf servers. This makes virtualization and its implications on performance one of the crucial techniques used for 5G. Virtualization is the natural enemy of

predictability and low latency posing a major obstacle when realizing URLLC. [6]

URLLC-focused applications require an end-to-end (E2E) delivery of data with reliability, security, and minimum latency.

The channel quality and lack of dedicated bandwidth can be an obstacle to meeting the desired latency requirement for URLLC.

Coexistence with EMBB:

The emerging 5G network must provide services to diversified applications with different requirements. Applications relying on URLLC require low latency with high reliability, whereas EMBB requires high data rates. For the existence of URLLC and EMBB in the same physical resource, as shown in (Figure2-4), an efficient coexistence method is needed to maintain the required QOS.

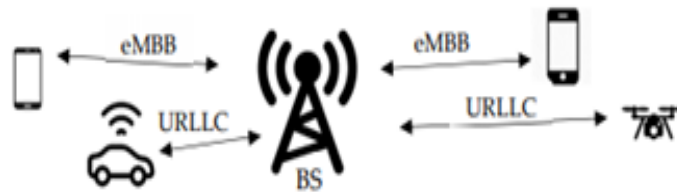

Figure( 2-4): Coexistence of URLLC and EMBB. BS, base station

The proposed agile 5G frame structure shows promising results for URLLC latency requirements by utilizing different transmission time intervals (TTIs) for URLLC and EMBB to meet their desired spectral efficiencies (SE). For example, URLLC traffic can be scheduled on a smaller TTI duration to achieve its low latency goal, and EMBB traffic can be scheduled with a long TTI duration to maintain its extreme SE requirements. [7]

to the fast development in communication technology and the emerging usage of Internet of Things (IOT) devices that produce a huge

amount of data, the fifth generation (5G) mobile network is introduced to support this development. This mobile network can provide many advanced communication features in cellular phones. But unfortunately, this technology faces many challenges. One of its defective challenges is the management of a massive number of devices running different services, so Software Defined Network (SDN) is proposed as a key technology to overcome this drawback.

SDN is an intelligent network that minimizes the usage of hardware. SDN's value in the 5G wireless networks lies specifically in its ability to deliver new capabilities in secure and trusted networks, such as network virtualization, automation and creation of new services in addition to virtualized resources. Also, SDN principles solve the Radio Resource Management problem in 5G networks for several use cases (interference management, mobile edge computing, RAN sharing). So, to cope with all previous challenges in the 5G mobile network and reduce costs, SDN. was proposed to provide the flexibility required in the 5G network architecture SDN also helps in the simplification of network management and configuration. It also reduces costs by the notarization of the 5G network functions. This is achieved due to SDN virtualized services in the network by separating the data transmission from the control of the network. In the SDN, the controller maintains the intelligence of the whole network. But on the other hand, the data plane is distributed into multiples of switches and routers that are responsible for flow forwarding or routing based on flow entries generated by the control plane. In SDN architecture, the Open Flow protocol is used to define data structures, messages, and procedures, to describe all the physical and logical elements. architecture of SDN is called Orion design the area controller is responsible for gathering information about



physical devices and linking information, managing topology in the intra-area, processing requests and updates for intra area routing.

The domain controller treats area controllers as devices and, through a distributed protocol, synchronizes the global view of the abstracted network. So, a horizontal communication module was proposed to enable the synchronization of network information among the domain controllers. They have evaluated their design based on the Dijkstra algorithm and they have measured the average delay and the throughput.[8]

solution that allows managers to perform management operations without having to individually configure the devices that compose the network. that is, to centralize the administration of a complex network while avoiding the tedious task of verifying and validating routing and Quality of Service (QOS) parameters one by one in each one of the network elements. To meet these requirements, paradigm of Software-Defined Networking (SDN). SDN consists of separating the control plane and the data plane in each intermediate device in the network. In this context, a centralized controller computes the routing operations and controls the network elements by commanding their corresponding forwarding operations. In this way, the SDN controller must be able to communicate with both the control plane (application) and the data plane (infrastructure). Nowadays, the most commonly used standard to perform this function is the OpenFlow protocol, which allows the communication of the controller with the nodes in the networks. Simultaneously, a new generation of mobile networks known as 5G (fifth generation) is being considered and undergoing a standardization process. 5G consists of communication systems, mainly mobile, that offer a real possibility of supporting the needs of a hyper connected world. Because the requirements of networks are always more and more

demanding and diverse, user profiles are better defined but also have different needs. this is where the concept of network slicing plays an extremely important role: it allows to develop a novel network model by virtually segmenting the resources offered by a physical infrastructure. As a result, 5G network slicing and the SDN architecture converge and complement each other. the SDN paradigm enables network architectures capable of managing an infrastructure in a virtual way by providing dynamic characteristics to a network that does not change in its physical elements, but in terms of configuration.[9]

# CHAPTER THREE

## METHODOLOGY

### 3-1 MATERIALS AND METHODS

#### 3-1-1 Dijkstra Algorithm

In this work, routing is based on Dijkstra algorithm. The basic principle is: Every time a new point is extended by the shortest distance, the distance between adjacent point is updated. Divide the head of the  $v$  group into two groups:

(1)  $u$ : the set of computed peaks (contains only the source point  $v'$  at the start).

(2)  $T = V - u$ : the set of peaks that have not yet been determined

Incrementally add the vertices from  $T$  to  $U$  to ensure:

(1) The length from the source point  $v'$  to other vertices in  $u$  is not greater than the shortest path length from  $v'$  to any vertex in  $T$ .

(2) Each vertex corresponds to a distance value

Peak in  $u$  length from  $v'$  to this head

Vertex in  $T$  : the shortest path length from  $v'$  to this vertex including only the vertex in  $u$  as the middle vertex .

the Dijkstra algorithm illustrated in the following pseudo code:

1: for all  $v \neq u$  such that  $l(v) = w(u, v)$  do

2:  $l(u) = 0$

3:  $T = u$

4: while  $T \neq V$  do

5: find  $v' \notin T$  such that  $\forall v \notin T, L(v') \leq L(v)$

6:  $T = T \cup v'$

7: for all  $v \notin T$  such that  $v'$  is adjacent to  $v$  do

8: if  $L(v) > L(v') + w(v', v)$  then  
 9:  $L(v) = L(v') + w(v', v)$   
 10: end if  
 11: end for  
 12: end while  
 13: end for

### 3-2: Performance Metrics

- Data rate

Required data rate is the main performance indicator for 5G . The accurate required data rate depends on Adaptive modulation and coding (AMC) as shown in equation.

$$DR = B * RC * M$$

Where:

DR is Data Rate,

B is Bandwidth

RC is Code Rate

M is Logarithm of actual data rate.

- Throughput

The system Throughput is the sum of data rates and essentially its band width consumption as shows in Equation

$$TH = \sum B * RC * M$$

Where:

TH is Throughput

B is Bandwidth

RC is Code Rate

M is Logarithm of actual data rate

From  $t = 0$  to  $T$ ,  $T$  is the total time of transmit.

- Bandwidth Utilization

Bandwidth Utilization is the percentage of bandwidth utilized

Of the total bandwidth available, as shown in Equation

$$BU = (BW/BWT) * 100$$

Where:

BU is Bandwidth Utilization

BW is Bandwidth located

BWT is Bandwidth available

- Transmission Delay

Delay is also called latency refer to the total time of

Transmit a specific size of data in Bite, can be measured by using Equation.

$$D = N/R$$

Where:

N is the number of bits

R is data rate.

# CHAPTER FOUR

## SIMULATION AND RESULTS

### 4-1 Simulation Description

This chapter give over view to the result on the simulated work, including the evaluation matrix.

Table below show simulation parameter used in the different scenarios of the simulation

**Table 4.1** : simulation parameter:

<b>Parameter</b>	<b>Value</b>
Number of all virtual node	8
Control node	3
Bandwidth	4MHZ
Number of bits	100Bit
Actual data rate	2
Code rate	0.5

## 4-2 Results and Discussion

4.1 A virtual network without SDN consist of eight nodes illustrated in figure 4.1

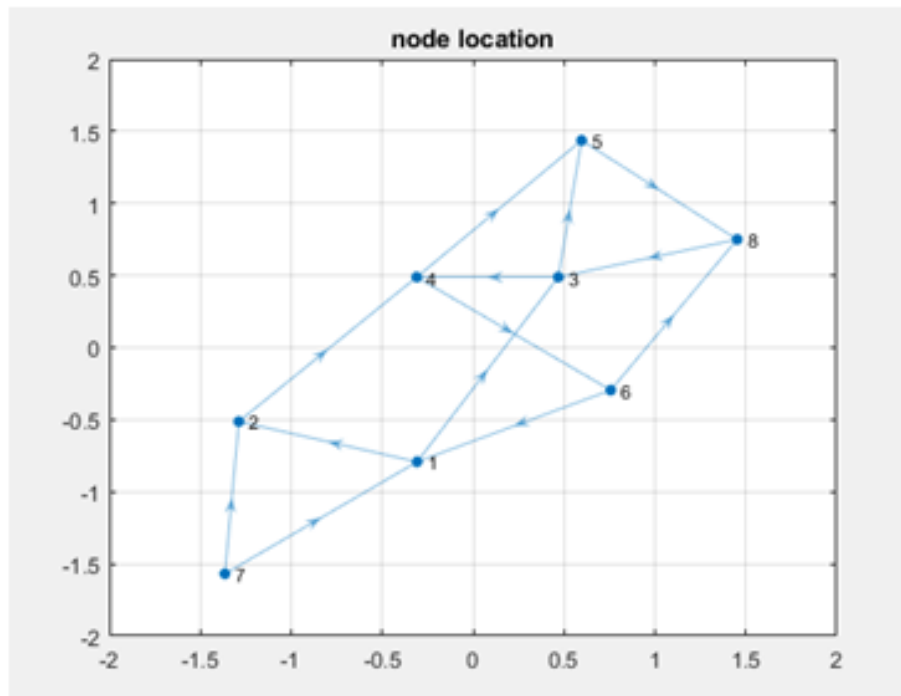

Figure 4.1 A virtual network without SDN

Figure 4.2 represent a 5G network topology using 3 nodes as the SDN controlle

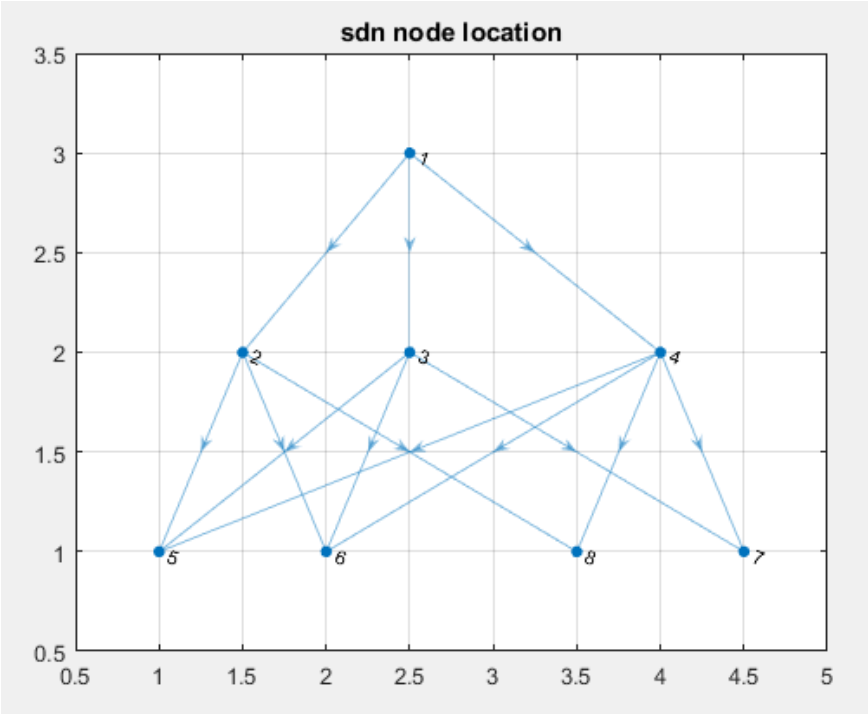

figure 4.2 A virtual network with SDN



## •Transmission Delay

Figure 4.3 represents the change in delay with time , and we note that delay changes linearly with time .

At point 27 we note that the delay is less than using SDN.

In the virtual network delay =25 ,and when applying SDN delay =7.

The decrease =25-7=18.

The percentage of decrease = $18/25*100\% =72\%$  .

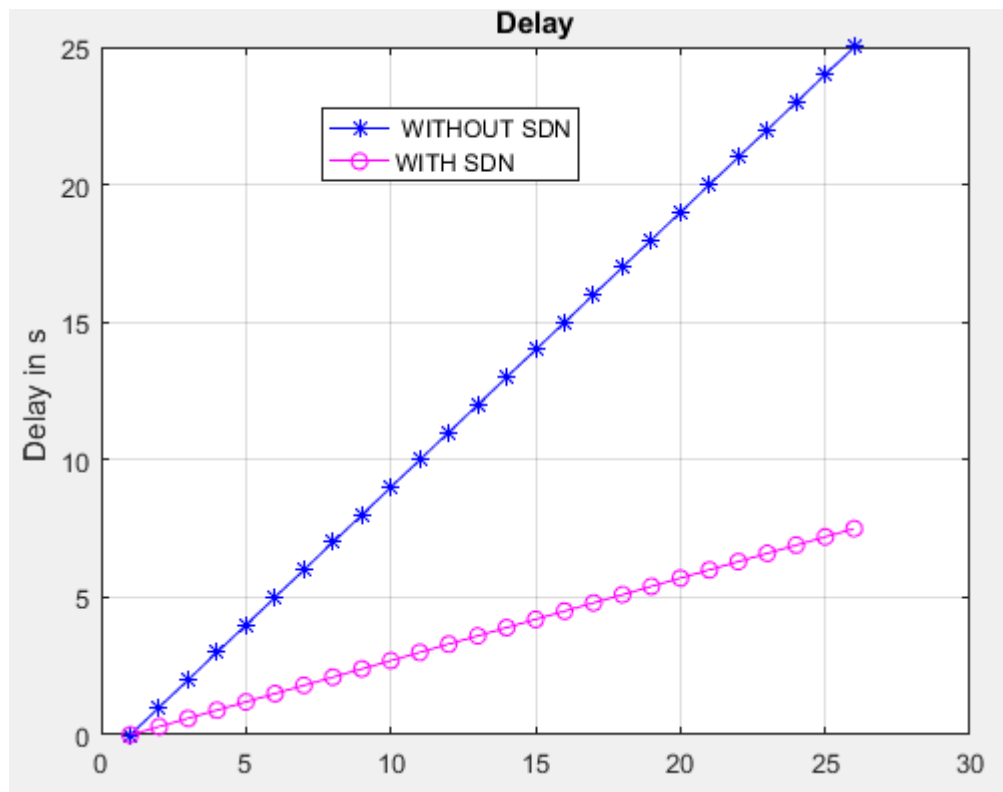

Figure 4.3 comparing delay with SDN and without SDN

## •Throughput

Figure 4.4 represents the change in throughput with time , and we note that throughput increases linearly with time .

In the virtual network at point 5 is equal to  $0.5 \cdot 10^6$  and when using SDN equal  $1.3 \cdot 10^6$  .

$$\text{Increment} = (1.3 - 0.5) \cdot 10^6 = 0.8 \cdot 10^6.$$

$$\text{Percentage increase} = 0.8 \cdot 10^6 / 0.5 \cdot 10^6 = 160\% .$$

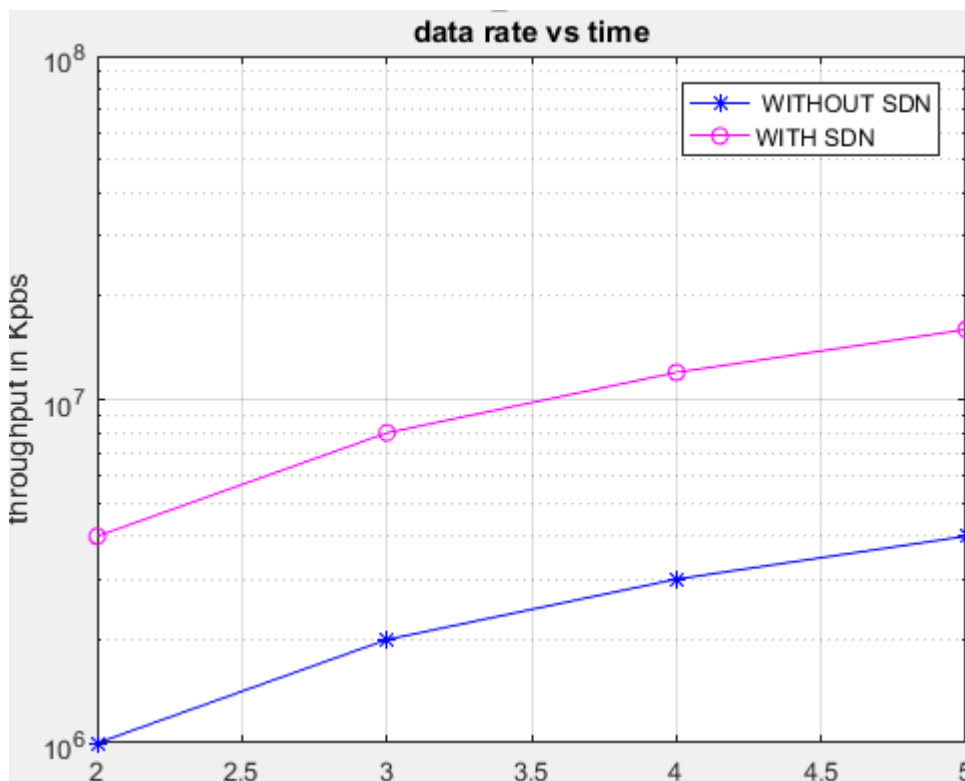

Figure 4.4 comparing throughput with SDN and without it

### •Bandwidth Utilization

Figure 4.5 represents the change in bandwidth, in the virtual network bandwidth = 4, and when using SDN = 4.75 .

The increase =  $4.75 - 4 = .75$ .

Percentage increase =  $.75/4 * 100\% = 18.75\%$  .

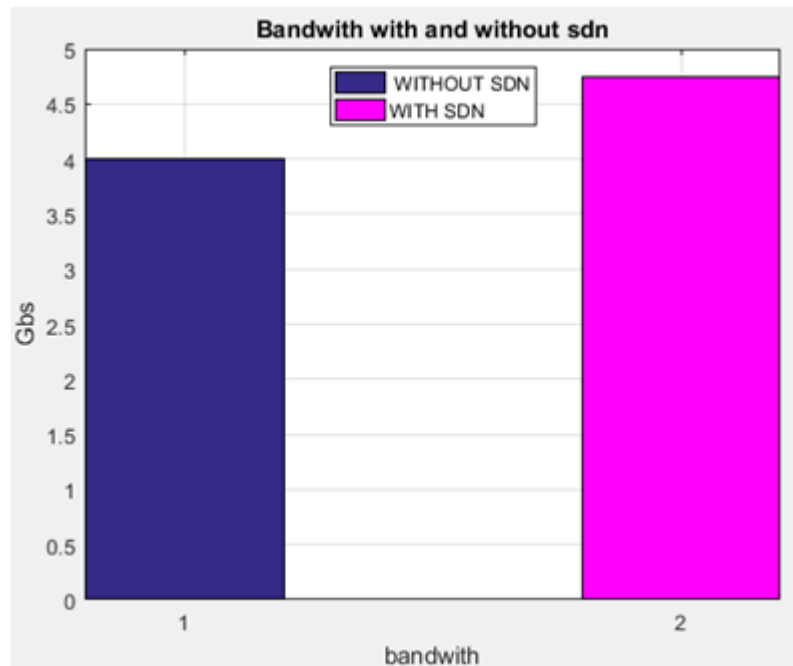

Figure 4.5 bandwidth with SDN and without it

# CHAPTER FIVE

## CONCLUSION AND RECOMMENDATION

### 5-1 Conclusion

The fifth-generation network is a network with high features in which the network parameters have been improved and thus improve the quality of service.

The short path algorithm has many advantages such as reducing the data path and throughput and delay.

In this research, specific specification was introduced MATLAB to design a topology for a traditional network with number of nodes and a topology for another network choosing a part of the nodes for the control (SDN).

The results were compared in the traditional network with the network when applying SDN , and the increase in throughput and bandwidth was observed in a linear, and the delay was also decrease in a linear manner.

The increase percentage was calculated for each of the throughput and bandwidth and found 160% and 18.75% ,respectively ,and the decrease in the delay was calculate and found 72% from the above , we note that the use of SDN led to an improvement in the service quality parameters mentioned above , and consequently to the increase in quality of service.

## **5-2 Recommendation**

- Use other type of simulation software such as MININET and OPNET.
- Measure other parameters in the network, such as jitter, packet loss etc.

## References

- [1] S. Hossain, "5G wireless communication systems," *American Journal of Engineering Research (AJER)*, vol. 2, no. 10, pp. 344-353, 2013.
- [2] E. Mataj, "Network slicing and QoS in 5G systems and their impact on the MAC layer," *Politecnico di Torino*, 2020.
- [3] A. A. Barakabitze, A. Ahmad, R. Mijumbi, and A. Hines, "5G network slicing using SDN and NFV: A survey of taxonomy, architectures and future challenges," *Computer Networks*, vol. 167, p. 106984, 2020.
- [4] T. Shuminoski, S. Kitanov, and T. Janevski, "Advanced QoS provisioning and mobile fog computing for 5G," *Wireless Communications and Mobile Computing*, vol. 2018, 2018.
- [5] F. López Rodríguez, U. Silva Dias, D. R. Campelo, R. d. Oliveira Albuquerque, S.-J. Lim, and L. J. GarcíaVillalba, "QoS management and flexible traffic detection architecture for 5G mobile networks," *Sensors*, vol. 19, no. 6, p. 1335, 2019.
- [6] S. Gallenmüller, J. Naab, I. Adam, and G. Carle, "5G QoS: Impact of Security Functions on Latency," in *NOMS 2020-2020 IEEE/IFIP Network Operations and Management Symposium*, 2020: IEEE, pp. 1-9.
- [7] M. A. Siddiqi, "5G ultra-reliable low-latency communication implementation challenges and operational issues with IoT devices," *IEEE Network*, 2019.
- [8] C. N. Tadros, M. R. Rizk, and B. M. Mokhtar, "Software defined network-based management for enhanced 5G network services," *IEEE Access*, vol. 8, pp. 53997-54008, 2020.
- [9] K. S. Ibarra-Lancheros, G. Puerto-Leguizamón, and C. Suárez-Fajardo, "Quality of service evaluation based on network slicing for software-defined 5G systems," *TecnoLogicas*, vol. 21, no. 43, pp. 27-41, 2018.

## Appendix: MATLAB Code

```
clc
clear all
close all
%%%%%%%%%%5g system parameters
n=8;%no. of all node
nc=3;%no. of sdn control node
Bw1=4;
Bw2=Bw1\nc;
data=100;
%%%%%%%%%%system model
s = [1 1 2 3 3 4 4 6 6 7 8 7 5];
t = [2 3 4 4 5 5 6 1 8 1 3 2 8];
G = digraph(s,t);
plot(G)
grid
title('node location')
figure
for n= 1:8
Result(n,1)= n * 0.002;
M1(n)=2;
C1(n)=0.5;
for i=1:100
    %Data Rate
DR1(n)=Bw1*M1(n)*C1(n);
    %Throughout
TH(n)=DR1(n)/Bw1;
    %DELAY
D(n)= data/(DR1(n));
    %%%all output system
```

```

x1(i,1)=DR1(n);
x2(i,2)=TH(n);
x3(i,3)=D(n);
end;
end
x=0:DR1(n);
%y=0:TH(n);
z=0:D(n);

%%%%%%%%%%%%%%%%%%%%%%%%%%%%%%%%%%%%%%%%%%%%%%%%%%%%%%%%%%%%%%%%%%%%%%%%5g system with SDN

s = [1 1 1 2 3 4 2 3 4 2 3 4 4];
t = [2 3 4 6 7 8 5 6 7 8 5 6 5];
P = shortestpath(G,1,8);%short path Dijkstra
G = digraph(s,t);
plot(G)
grid
P = shortestpath(G,7,8);
title('sdn node location')
figure
for n= 1:8
Result(n,1)= n * 0.002;
M2(n)=2;
C2(n)=0.5;
for i=1:100
    %Data Rate
DR2(n)=Bw2*M2(n)*C2(n);
    %Throughout
TH2(n)=DR2(n)/Bw2;
    %DELAY
D2(n)= data/(DR2(n));

```



```

%%%all output system
x21(i,1)=DR2(n);
x22(i,2)=TH2(n);
x23(i,3)=D2(n);
end
end
tic
%TH2(n)=k;
K=x*nc;
%y2=0:TH2(n);
L=z*0.3;
%*****Bandwith
bar([Bw1 0],0.4)
hold on
bar([0 Bw1+Bw2],0.4,'m')
grid
xlabel('bandwith')
ylabel('Gbs')
title('Bandwith with and without sdn')
legend(' WITHOUT SDN','WITH SDN')
figure

%*****THROUGHPUT

semilogy(x*1000000,'b-*)
hold on
semilogy(K*1000000,'m-o')
xlabel('time in s')
ylabel('throughput in Kpbs')
title('data rate vs time')
legend(' WITHOUT SDN','WITH SDN')

```

```
grid
%*****delay
figure
plot(z,'b-*')
hold on
plot(L,'m-o')
%hold on
grid
ylabel('Delay in s ')
title(' Delay ')
legend(' WITHOUT SDN','WITH SDN')
```