



**Sudan University of Sciences and Technology**

**College of Engineering**

**School of Electrical and Nuclear Engineering**



## **Harmonic Control In 33/11 three Phase Distribution Transformer**

**التحكم في التوافقيات في محول التوزيع 11/33 ثلاثي الطور**

**Prepared By:**

- 1. Rahama Ibrahim Adam Haroon**
- 2. Mohammed Ali Abo al-gasim Ahmed**
- 3. Hashim Omer Hassan Musa**
- 4. Hisham Hussein Bahareldein Abdallah**

**Supervised By:**

**Ust.Gaffar Babikr Osman**

**November 2020**

## الآية

﴿مُحَمَّدٌ رَسُولُ اللَّهِ وَالَّذِينَ مَعَهُ أَشِدَّاءُ عَلَى الْكُفَّارِ رُحَمَاءُ  
بَيْنَهُمْ تَرَاهُمْ رُكَّعًا سُجَّدًا يَبْتَغُونَ فَضْلًا مِنَ اللَّهِ وَرِضْوَانًا  
سِيمَاهُمْ فِي وُجُوهِهِمْ مِنْ أَثَرِ السُّجُودِ ذَلِكَ مَثَلُهُمْ فِي  
التَّوْرَةِ وَمَثَلُهُمْ فِي الْإِنْجِيلِ كَزَرْعٍ أَخْرَجَ شَطْأَهُ فَآزَرَهُ  
فَاسْتَغْلَظَ فَاسْتَوَى عَلَى سَوَاقِهِ يُعْجِبُ الزُّرَّاعَ لِيغِيظَ بِهِمُ  
الْكُفَّارَ وَعَدَّ اللَّهُ الَّذِينَ آمَنُوا وَعَمِلُوا الصَّالِحَاتِ مِنْهُمْ  
مَغْفِرَةً وَأَجْرًا عَظِيمًا﴾

[الفتح: ٢٩]

## **DEDICATION**

Anyone who ignites a flame of hope for science ...

For those who see us a good seed in the path of science ...

Everyone has given his efforts for science...

To our honorable families and our parents...

To the dear patch...

Take our thank.

## **ACKNOWLEDGEMENT**

We offer the most beautiful words of thanks and gratitude from the heart, with love and friendliness And respect and appreciation to all staff of the department and to our teacher\ GaffarBabiker. And the engineers on the Khartoum Automation center.

## ABSTRACT

The Harmonics in Distribution Systems come from transformers or saturation reactors, arc furnace, welding machines, florescent lamps, rotating machines and power electronics devices. In general, the nonlinear loads in which the relationship between the voltage and current is not constant.

It is considered that there is no risk of harmful perturbation from 5 to 10%. Above 10%, problems will certainly occur.

Equipments can be affected by the harmonics like transformers with increase of losses, risk of overheating, noise and even insulation stress problems. Cables that can heat too much due to as Kelvin effect above 400 Hz. Induction relays and meters that are potpale by harmonic torques giving incorrect tripping and readings.

The solutions that can be used to improve the p.f. and to protect the capacitors are either de-rate the capacitors or using detuning reactors, and also by using harmonic filters.

this thesis presents the definitions of harmonics, generation, causes, analysis and solutions due to IEEE 519 standard of harmonics.

In this Research the sources of harmonics and their effects in distribution system equipment are illustrated with the methods that are used to analyze and mitigate it

A case study of Sudanese Electricity Distribution Company (SEDC) network (AL OMERA Substation) was investigated using Network Analyzer (AR5) for the reading, and ETAP simulation program.

The results of harmonic analysis were compared with IEEE519-1992 limits(5%VTHD). It was found that the total harmonic distortion limit for current in the simulated case study network exceeded the limits(9.55 %VTHD).hence harmonic mitigation solution chosen was the passive filter.

## المستخلص

وجود التوافقيات في أنظمة التوزيع ينتج من التشبع في محولات القدرة، واستخدام افران القوس الكهربى، وآلات اللحام ، ومصابيح الفلورسنت ، والآلات الدوارة ، وأجهزة إلكترونيات القدرة.

وبمعنى اشمى الأحمال غير الخطية التي تكون فيها العلاقة بين الجهد والتيار غير ثابتة. كما انه اذا تعدى معامل التشويه التوافقي عن نسبة معينة (10%) ، ستحدث المشاكل بالتأكيد. يمكن أن تتأثر المعدات بالتوافقيات مثل المحولات مع زيادة الخسائر ومخاطر ارتفاع درجة الحرارة والضوضاء وحتى مشاكل إجهاد العزل. الكابلات التي يمكن أن تسخن كثيرًا والمرحلات وأجهزة القياس تفصل وتتغير قراءتها نتيجة للزعوم الإضافية الناتجة من التوافقيات .

و تكمن الحلول بالنسبة لمشاكل التوافقيات في تحسين معامل القدرة بواسطة المكثفات، وحماية هذه المكثفات باستعمال الملفات مع المكثفات بالإضافة الى استعمال المرشحات للحد من خطورة هذه التوافقيات .  
تتناول هذه الرسالة تعريف التوافقيات و مولداتها و اسبابها و تحليلها و معالجتها حسب المواصفات القياسية العالمية (IEEE 519 Standard for harmonics )

و كما ان الهدف الاساسي من هذه الرسالة هو تقليل التوافقيات في منظومة التوزيع للقدرة الكهربائية. في هذا البحث تم توضيح مصادر التوافقيات وتأثيراتها في معدات نظام التوزيع بالإضافة للطرق المستخدمة لتحليلها ومعالجتها .

جزء من شبكة الشركة السودانية لتوزيع الكهرباء ( SEDC) تم التحقق منها كدراسة لخط (البوستة محطة الامراء الفرعية) تمت دراستها باستخدام محلل الشبكة ( PSW2.3) للقراءة ، وعمل محاكاة ببرنامج ETAP. تمت مقارنة نتائج التحليل التوافقي مع حدود (IEEE519-1992). (VTHD) وجد أن حد التشويه التوافقي الكلي للتيار في شبكة دراسة الحالة المحاكاة قد تجاوز الحدود ولذا تم اختيار طريقة المرشحات السلبية كطريقة للمعالجة.

# TABLE OF CONTENTS

Title		Page no
الآية		I
NOITACIDED		II
ACKNOWLEDGMENT		III
ABSTRACT		IV
المستخلص		V
TABLE OF CONTENTS		VI
LIST OF FIGURES		IX
LIST OF TABLES		XI
LIST OF ABBREVIATION		XII
<b>CHAPTER ONE</b>		
<b>INTRODUCTION</b>		
1.1	General Overview	1
1.2	Research Problem	1
1.3	Research Objectives	1
1.4	Methodology	2
1.5	Project layout	2
<b>CHAPTER TWO</b>		
<b>Power system substation</b>		
2.1	Introduction	3
2.2	Substation equipment	4
2.3	Roles of Substation	7
2.4	Substations types	7
2.4.1	Transmission substations	8
2.4.2	Distribution Substation	8

2.5	substation bus scheme	9
<b>CHAPTER THREE</b> <b>Power System Harmonic</b>		
3.1	Introduction	13
3.2	Nature of harmonics	13
3.3	Definitions	14
3.3.1	Harmonic factor (Distortion Factor)(DF)	14
3.3.2	Total demand distortion(TDD)	14
3.3.3	Total harmonic distortion	15
3.3.4	Individual harmonic coefficients	16
3.3.5	fourier	16
3.3.6	TIF Weighting factor	17
3.3.7	Point of common coupling (PCC)	18
3.4	Normal flow of harmonic currents	18
3.5	Source of harmonic	19
3.6	Effect of Harmonic	28
3.7	Harmonic Mitigation Techniques	31
3.8	HARMONIC FILTERS	32
3.8.1	Passive Filters	32
3.8.2	Active Harmonic Compensation Systems	34
<b>CHAPTER FOUR</b> <b>Result and Discussion</b>		
4.1	Information about the Substation	36
4.2	Case study	37
4.3	Etap soft wore program	37
4.4	PWS 2.3 device	37
4.5	Scenario's	38



4.6	Harmonic Analysis by ETAP	41
<b>CHAPTR FIVE</b> <b>CONCLUSION AND RECOMMENDATION</b>		
5.1	Conclusion	50
5.2	Recommendation	50
	References	52

## List of Figures

Figure No	Figure Title	Page No
2.1	Typical distribution system showing component parts.	4
2.2	single bus scheme	10
2.3	double bus double breaker scheme	10
2.4	double bus single breaker scheme	11
2.5	Ring bus scheme	11
2.6	main and transfer bus scheme	11
2.7	different schemes of substation bus bars	12
3.1	Location of the point of common coupling	18
3.2	Normal flow of harmonic current	19
3.3	Transformer magnetizing current curve	20
3.4	non sinusoidal field distribution of rotating machines.	20
3.5	Voltage-current characteristics	21
3.6	Voltage and current waveforms of an arc furnace.	22
3.7	Harmonic Source waveform for VFD	23
3.8	Harmonic Source Spectrum for VFD	24
3.9	Harmonic Source waveform for UPS	24
3.10	Harmonic Source Spectrum for UPS	25
3.11	harmonic spectra of flourescent lamp for phase current	26
3.12	Tuned series Passive filter	32
3.13	Shunt passive filter type	32
3.14	Single Tuned Filter With Frequency Response Characteristics	33
3.15	General procedures for designing individually tuned filter steps for harmonic control	34
3.16.a	Active filter fundamental system configurations(Shunt active filter),	35
3.16.b	Active filter fundamental system configurations(Series active filter)	35

4.1	Single line diagram of EL OUMERA substation	36
4.2	Portable Network Analyzer PSW2.3	39
4.3	Connection diagram of PSW 2.3phase 3wires system	40
4.4	ActualreadingfromPSW2.3	41
4.5	Indicates buses withTHD(Individual Harmonic Distortion)	42
4.6	Bus 5 spectrum	43
4.7	Bus 5 wave form	43
4.8	Voltage spectrum at Bus5	45
4.9	Overall system harmonic load flow result for the second scenario	46
4.10	Overall system harmonic load flow result for the third scenario	47
4.11	Spectrum at fliter	47
4.12	wave form at fliter	48
4.13	Bus5 Spectrum at fliter	48
4.14	Bus 5 wave form at filter	49

## LIST OF TABLE

Table	Title	page
3.1	Current distortion limits for general distribution system (120 V Through 69000 V)	15
3.2	Ieee std-519-for voltage distortion	15
3.3	harmonic current of the arc furnances	21
3.4	Harmonic content of PSW	28
3.5	maximum harmonic amplitude due to	30
4.1	Load flow bus data	38
4.2	Load flow load data	39
4.3	VIHD (Individual harmonic)	41
4.4	VTHD (Total Harmonic Distortion) report	44

## List of abbreviation

Abbreviation	Meaning
DC	Direct Current
AC	Alternate Current
RMS	Root Mean Square
IEEE	Institute of Electrical and Electronic Engineering
DF	Distortion Factor
IDF	Input Displacement Factor
THD	Total Harmonic Distortion
THD <sub>v</sub>	Total Harmonic Voltage Distortion
THD <sub>i</sub>	Total Harmonic Current Distortion
TDD	Total Demand Distortion
EMF	Electro Magnetic Force
PF	Power Factor
DPF	Distorted Power Factor
TPF	Total Power Factor
UPS	Uninterruptable Power Supply
VFD	Variable Frequency Drives
HVDC	High Voltage Direct Current
DFT	Discrete Fourier Transform
FFT	Fast Fourier Transform
ETAP	Electrical transient Analyzer Program
SMPS	Single-Phase Switched Mode Power Supplies
PMW	Pulse Width Modulation
EMI	Electromagnetic Interference
RFI	Radio Frequency Interference
LHF	Line Harmonic Filters
PCC	Point of Common Coupling
IHD	Individual Harmonic Distortion
ASUM	Arithmetic Summation
AF	ActiveFILTER

# CHAPTER ONE

## INTRODUCTION

### 1.1 General Concept

An electric power system is a network of electrical components used to supply, transfer and use electrical power. This power system is known as the grid and can be divided into generation, transmission and distribution systems.

Transmission system represents the connection between generation and distribution systems. The basic purpose of transmission system is to transfer energy from generating plants at different locations to distribution centres.

Generally, transmission system is consisted of transmission lines and substations.

The substation is assembly of apparatus to change, control and improve the characteristics (voltage, frequency, power factor ... etc.) of electric supply. The classification of substation depends on different ways like the classification according to requirement such as voltage level, transformer capacity and transmission, distribution substation.

Substations play basic role in transmitting the energy from the generation to the load. At these days' substations help in control and protection of power system and it has big deal with improving the quality of electricity production because the electricity is like any product needs to be evaluated from different vision such as economic, reliability and its effect in the equipment of the costumers. Depending on this designing of substation is important step to maintain good power quality in the power system which conducted in a voltage and frequency that stays within the limits.

### 1.2 research Problem:

As technical and economic losses result in reduction the system's efficiency, also it affects the equipment performance characteristics .Center area of Khartoum suffering severe under voltage, equipments work at values less than the rated because of increasing load and low capacity of transformers, thus it affects continuity of supply and service reliability .Since the supply doesn't meet the specification requirement of the system that causes economical losses .The proper design according to national standard and the country requirement avoid these technical and economic losses and leads to good results.

### 1.3 Objectives:

The objectives of this research can be summarized as follow:

- To present general characteristics of the harmonics, harmonic indices and measure the distortion of the wave.
- To identify the harmonics sources and explain the harmonics effects in the different components of a distribution system.
- To study the methods used in harmonic analysis and scenarios of harmonic mitigation.
- Take a case study for harmonic analysis using simulation program. If the distortion exceeds the acceptable limit mitigation must be done.

### **1.4 Research Methodology:**

The data was collected by different method. Some of these data was collected from The Sudanese Electric Holding Company. Data was also collected by reading meters and nameplates of some equipment. The simulation was done by using ETAP program. This simulation is concerned with load flow and short circuit studies. Analytical calculations are used to obtain results from planning study. Google earth was used to determine the area of the substation and the path of underground cable.

### **1.5 Research Structure:**

This project consists of five chapters

Chapter one : gives an introduction about the principles of the project, in addition its reasons, motivation and objectives.

Chapter two: represents functions of substation, classifications and main components of the substation.

Chapter three discusses the research's main studies and how they were done.

Chapter

four :shows the results of planning, load flow and short circuits studies and analysis of these results.

Chapter five: provides the conclusion and recommendations.

# CHAPTER TWO

## Power system substation

### 2.1 Introduction:

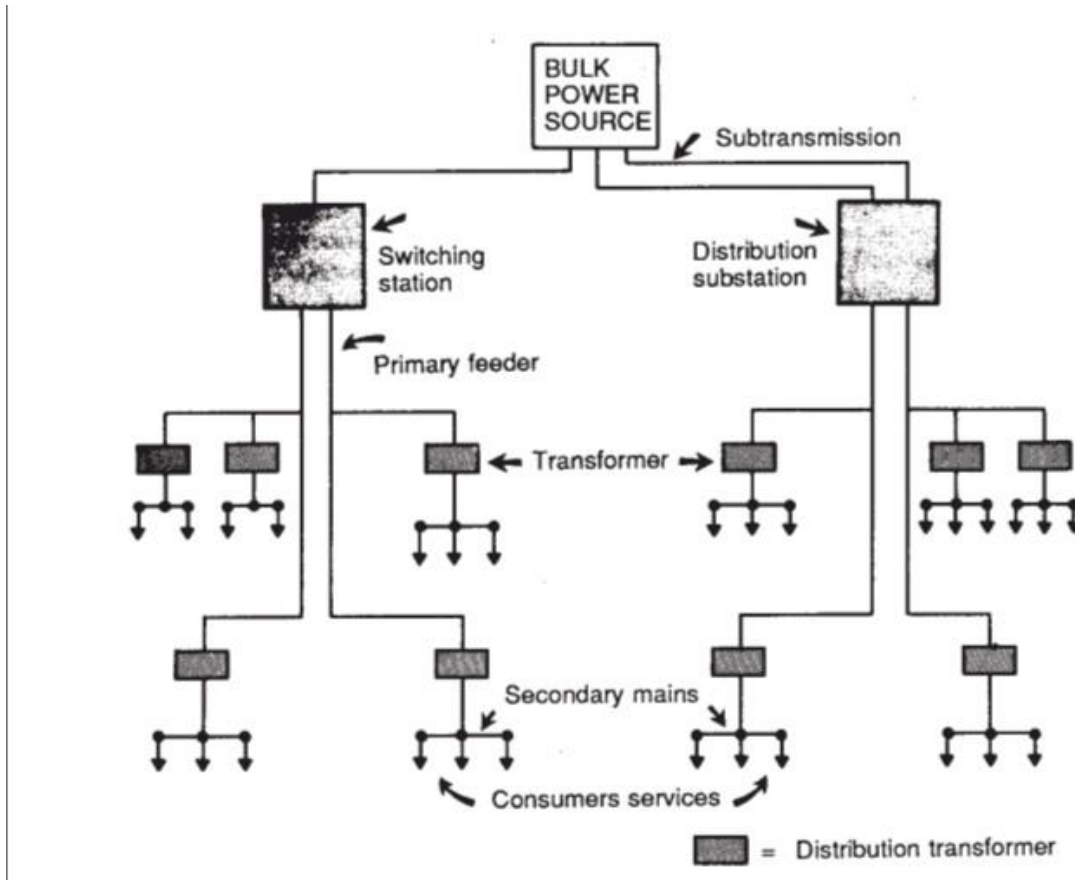
The electricity substation is a network of electrical equipment which is connected in a structured way in order to supply electricity to end consumers. There are numerous electrical substation components like outgoing and incoming circuitry each of which having its circuit breakers, isolators, transformers, and bus bar system and so on. For the smooth functioning of the system. The power system is having numerous ingredients such as distribution, transmission, and generation systems and Substations act as a necessary ingredient for operations of the power system. The substations are entities from which consumers are getting their electrical supply to run their loads while required power quality can be delivered to the customers by changing frequency and voltage levels etc. The electricity substation designs are purely dependent on the need, for instance, a single bus or complex bus system etc.

Moreover, the design is also dependent on the application as well, for instance, indoor substations, generation substations, transmission substations, pole substations, outdoor substation, converter substation, and switching substation etc.

There is a need of collector substation as well in cases of large power generating systems e.g. multiple thermal and hydropower plants connected together for transfer of power to a single transmission unit from numerous co-located turbines. The following in figure 2.1 are major electrical components of substations and their working. Each component functions are explained in detail with machinery, substation components diagram .[14

]





**Figure 2.1: Typical distribution system showing component parts.**

## **2.2 Substation Equipment:**

The main components of any substation are:

- Power Transformers:

The construction of a simple two-winding transformer consists of each winding being wound on a separate limb or core of the soft iron form which provides the necessary magnetic circuit. This magnetic circuit, known more commonly as the “transformer core” is designed to provide a path for the magnetic field to flow around, which is necessary for induction of the voltage between the two windings. However, this type of transformer construction where the two windings are wound on separate limbs is not

very efficient since the primary and secondary windings are well separated from each other. This results in a low magnetic coupling between the two windings as well as large amounts of magnetic flux leakage from the transformer itself. But as well as this “O” shaped construction, there are different types of “transformer construction” and designs available which are used to overcome these inefficiencies producing a smaller more compact transformer. Increasing and concentrating the magnetic circuit around the coils may improve the magnetic coupling between the two windings, but it also has the effect of increasing the magnetic losses of the transformer core. As well as providing a low reluctance path for the magnetic field, the core is designed to prevent circulating electric currents within the iron core itself. In all types of transformer construction, the central iron core is constructed from of a highly permeable material made from thin silicon steel.

The distribution transformer main part:

- i. Radiators
- ii. Breather unit Conservator
- iii. Pressure relief system
- iv. Oil level indicator
- v. Temperature dial
- vi. Tap changer HV/ LV bushing
- vii. Oil filling
- viii. plug Drain plug
- ix. Cable box

- Circuit breakers:  
connect/ or disconnect the power during normal (maintenance, extension ...) or abnormal conditions (faults). These devices have mechanisms for arch extinguish produced during breaking periods. There are many types of circuits' breakers (air blast, oil, vacuum, SF6...).
- Isolators:  
used to provide the visual isolation after already disconnecting the circuit with circuit breakers. There are interlock between the isolator and circuit breaker to grantees that isolator are opened before the circuit breaker because the isolators are not equipped with arch extinguished mechanisms.
- Busbars:  
used to collect the electrical power before distributed it into primary feeders. The busbar are classified into many types according to substation rating.
- Voltage and current transformers:  
special transformers uses for measuring and protection purpose. There always step down the current and voltage to values suitable for measuring and protection devices.
- Capacitors and reactors:  
there can be connected in series or parallel and used for voltage regulation by generation or absorbing the reactive power.
- Lighting arresters:  
used to protect the substation devices from the high voltage generated due the lighting stroke the substation.
- Earthing system:

uses to protect the power system operators from the ground discharge occur in substation devices.

- Earthing switches:

this switches use during maintenance to ground the device in order to protect the power system engineers.

- Protection and measurement panels

- Control panel and communication devices

- Batteries to supplies protecting and measuring relays.

- Current limiting reactors uses to limit the fault currents

-Line trap uses to protect the substation from high voltages generated due to swatting of the breaker.

### **2.3 Roles of Substation:**

- Facilitate the regional interconnection for neighbouring electrical grids. this increase system efficiency and reliability.
- Facilitate the connection of different generation station into electrical power grid.
- Step down the high and medium voltages to value suitable for distribution at the customers' level.
- Regulate the power system voltage using the tap changer with the power transformer, capacitors and reactors (the devices lactated at the substation).
- Facilitate the disconnection of some of subsystem (such as transformer, transmission line) to achieve maintenance, programming tests or even extension works using disconnection switches at the substation.

### **2.4 Substations types:**

There are two main types of substations:

### **2.4.1 Transmission substations:**

These substations transform the high transmission voltage into lower high voltage or even medium voltage before delivering the power to distribution centers.

i. Step-up Transmission Substation

step-up transmission substation receives electric power from a nearby generating facility and uses a large power transformer to increase the voltage for transmission to distant locations

ii. Step-down transmission substation

are located at switching points in an electrical grid. They connect different parts of a grid and are a source for subtransmission lines or distribution lines. The step-down substation can change the transmission voltage to a subtransmission voltage

### **2.4.2 Distribution Substation**

distribution substation is one of the important components of the distribution system. Since the electrical power grid can be considered as a simple circuit including power source, its transmission and distribution lines, and finally the load consumers. In this network the substation plays an important role by converting the voltages in order to match the transmission and distribution levels.

distribution substations are located near to the end-users. distribution substation transformers change the transmission or sub transmission voltage to lower levels for use by end-users

in general the substations are divided according to their insulating design into:

- Air Insulated substation (AIS) :-

all the circuits are located in the external space and the circuits are isolated using the air.

- Gas Insulated Substations (GIS):-  
substations that enclose high voltage bus, switches, and breakers in containers filled with SF6 gas. GISs greatly reduce the substation footprint and protect equipment from many causes of equipment failure.

**i. Underground Distribution Substation**

substations are also located near to the end-users. Distribution substation transformers change the subtransmission voltage to lower levels for use by end-users

**ii. Substation location**

- 1- Locate the substation as much as feasible close to the load centre of its service area.
- 2- Locate the substation such that proper voltage regulation is obtained without extensive measurement.

Locate the substation such that it provides proper access for incoming subtransmission lines to select ideal location for a substation, the following rules should be observed

- 3- and outgoing primary feeders.
- 4- The selected substation location should provide enough space for the future substation expansion.

## **2.5 Substation Bus Schemes:**

The electrical and physical arrangement of the switching and busing at substation are determined by substation type or scheme. The selection of particular substation scheme is based on safety, reliability, economy, simplicity and other consideration. The most commonly used substation bus schemes are (as shown in figure. 3).

1-single bus scheme

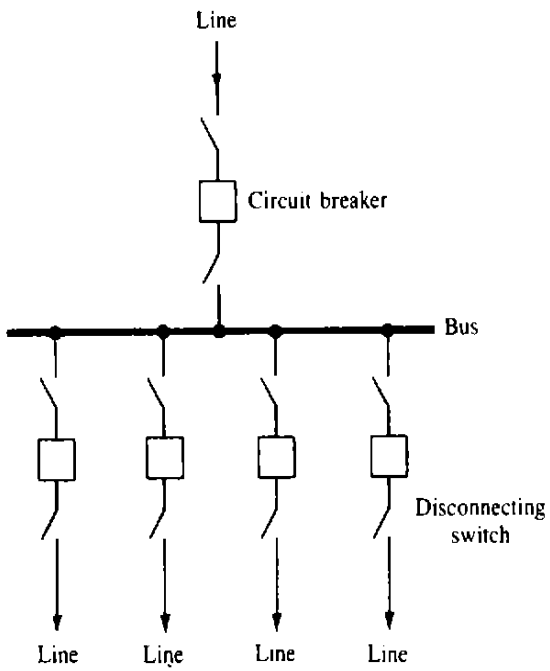
2-double bus double breaker scheme

3-double bus single breaker scheme

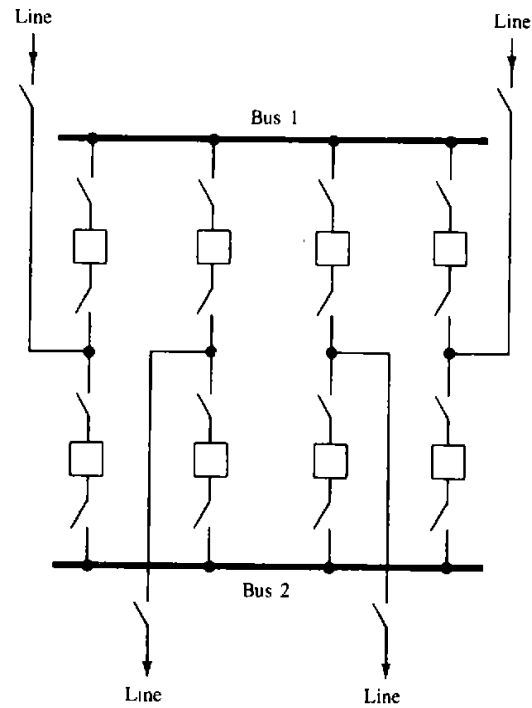
4-main and transfer bus scheme

5-Ring bus scheme

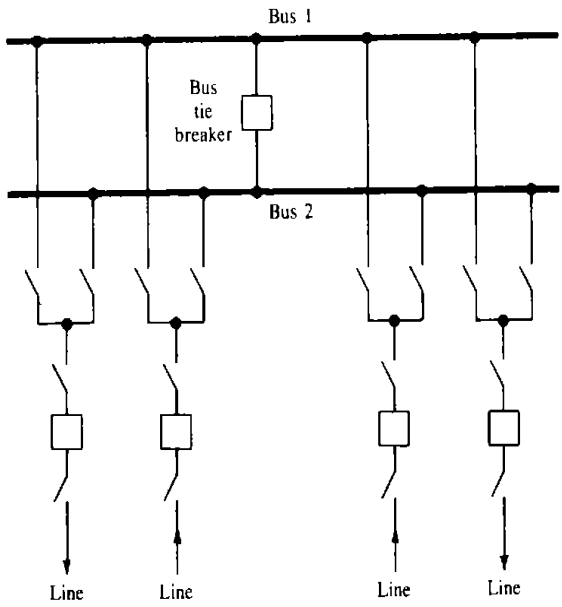
6-breaker and half scheme



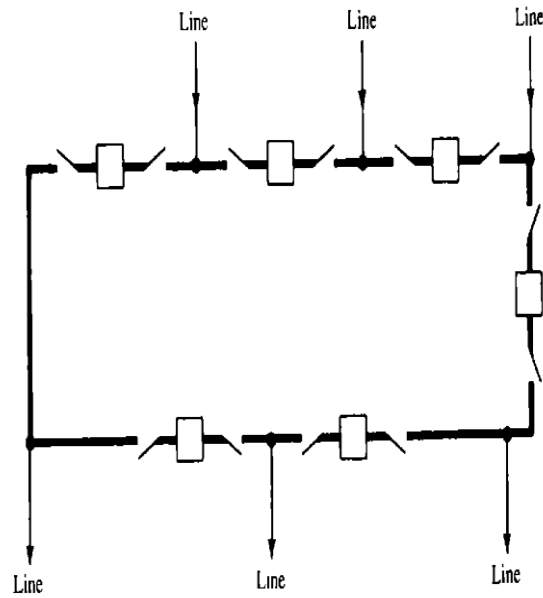
**Figure 2.2 single bus scheme**



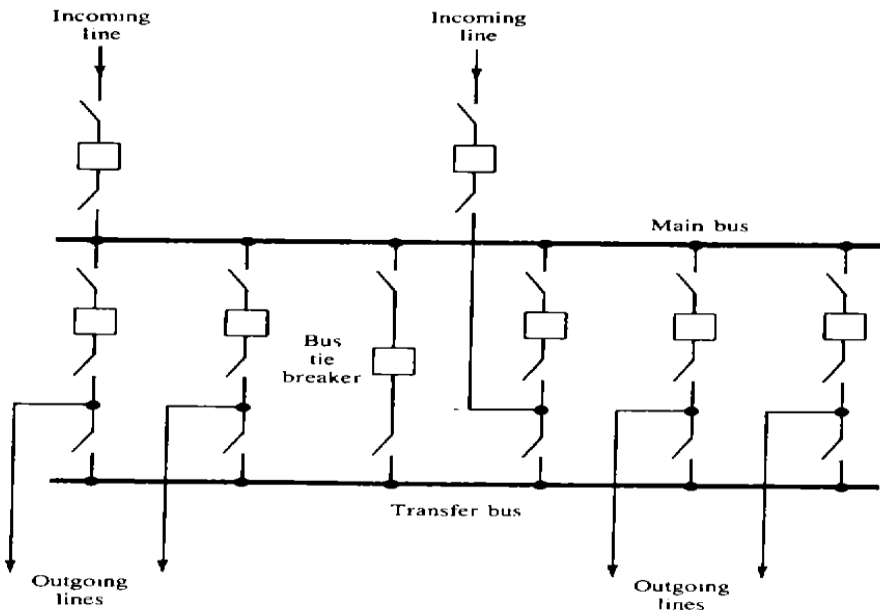
**Figure 2.3 double bus double breaker scheme**



**Figure 2.4 double bus single breaker scheme**

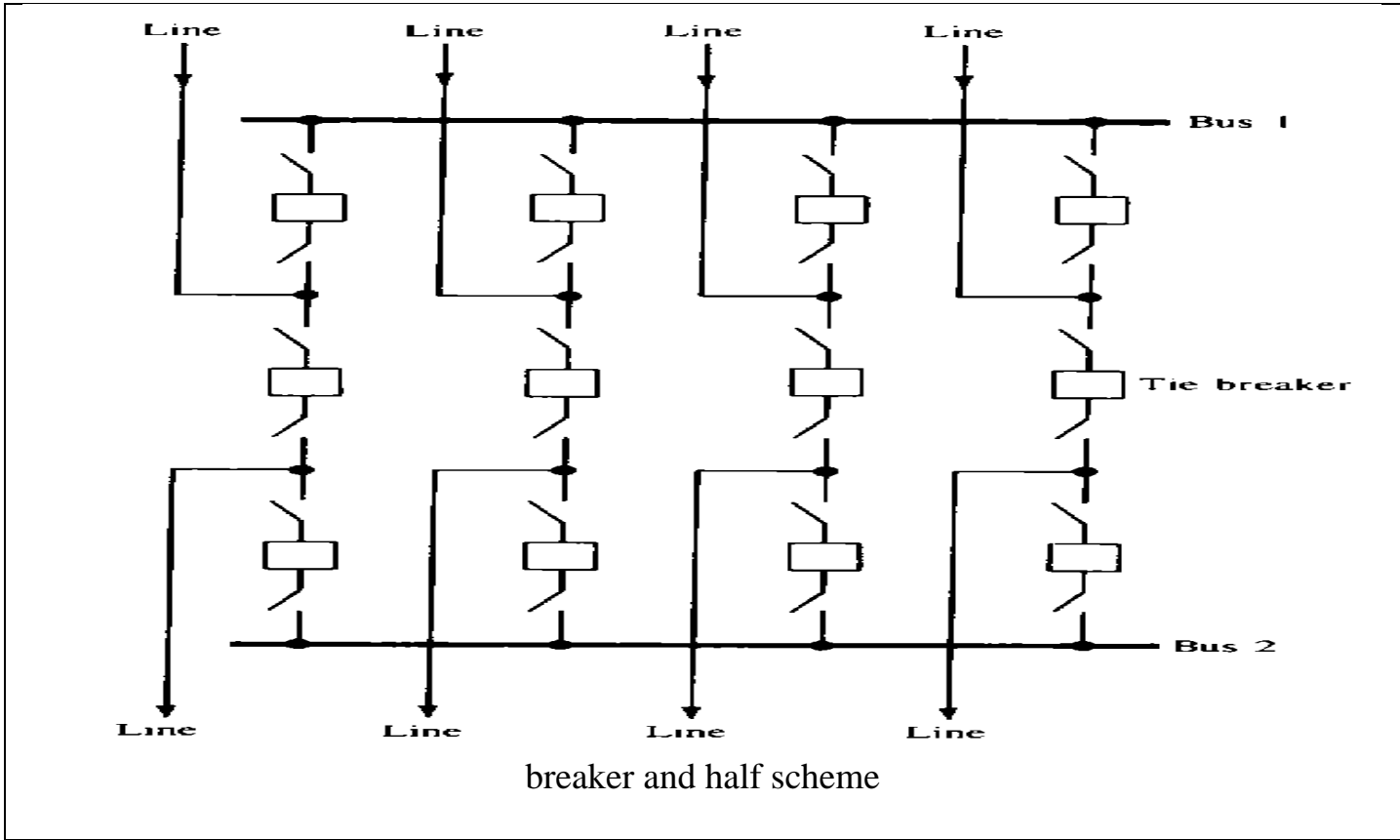


**Figure 2.5 Ring bus scheme**



**Figure 2.6 main and transfer bus scheme**





**Figure 2.7: different schemes of substation busbars**

# CHAPTER THREE

## Power System Harmonic

### 3.1 Introduction:

normally in electrical alternating current power system , the voltage varies sinusoidally at specific frequency usually 50 or 60 Hz. When a linear electrical load is connected to the system ,it draws a sinusoidal current at the same frequency as voltage .

When a non-linear load such as a rectifier, is connected to the system ,it draws a current that is not necessarily sinusoidal. The current waveform can become quite complex, depending on the type of the load and its interaction with other components of the system. Regardless of how complex the current waves becomes , As described through fourier series analysis, it is possible to decompose it into a series of a simple sinusoidal wave , which start at the fundamental power system frequency .

In most cases, power electronic equipment are considered to be the cause of harmonic . Harmonic are also produced by a large variety of conventional equipment like power generation equipment “ slot harmonic” induction motor “ saturated harmonic” , transformer “over excitation leading to saturation”, magnetic ballast\_ floursent lamp “ arcing ” and ac electric furnace.

All these devices will cause harmonic current to flow and some devices directly produce voltage harmonic.

### 3.2 Nature of harmonics

Any distortion that occurs in waveform of voltage called harmonic phenomena and main reason refers to non-linear load that connected to the system. Also any oscillation or perturbations in waveform that let it in abnormal condition which called harmonics .

Waveform distortion, often referred to as dirty power, becomes serious when the power deviates significantly from a pure sine wave.

The electronic devices being used the term harmonics comes into use.

Harmonic should be taken seriously but they are not the only used cause of electrical problem. If have tried everything and are still having problem and have a lot of electronic devices it is something to think about. Any distortion in the voltage or current wave causes harmonics.[13]

### 3.3 Difinitions:

#### 3.3.1 Harmonic Factor (Distortion Factor) (DF):

The ratio of the root-mean square of the harmonic content to the root-mean-square value of the fundamental quantity, expressed as a percent of the fundamental. [1]

$$DF = \sqrt{\frac{\text{sum of squares of amplitudes of all harmonics}}{\text{square of amplitude of fundamental}}} \cdot 100\%$$

#### 3.3.2 Total demand distortion (TDD):

The total root-sum-square harmonic current distortion, in percent of the maximum demand load current (**15** or **30** min demand).as shown in the table 3.1 and table 3.2.

Table3.1

**Current Distortion Limits for General Distribution Systems  
(120 V Through 69 000 V)**

Maximum Harmonic Current Distortion in Percent of $I_L$						
Individual Harmonic Order (Odd Harmonics)						
$I_{sc}/I_L$	<11	$11 \leq h < 17$	$17 \leq h < 23$	$23 \leq h < 35$	$35 \leq h$	TDD
<20*	4.0	2.0	1.5	0.6	0.3	5.0
20<50	7.0	3.5	2.5	1.0	0.5	8.0
50<100	10.0	4.5	4.0	1.5	0.7	12.0
100<1000	12.0	5.5	5.0	2.0	1.0	15.0
>1000	15.0	7.0	6.0	2.5	1.4	20.0

Even harmonics are limited to 25% of the odd harmonic limits above.

Current distortions that result in a dc offset, e.g., half-wave converters, are not allowed.

\*All power generation equipment is limited to these values of current distortion, regardless of actual  $I_{sc}/I_L$ .

where

- $I_{sc}$  = maximum short-circuit current at PCC.
- $I_L$  = maximum demand load current (fundamental frequency component) at PCC.

**Table3.2:**

**Voltage Distortion Limits**

Bus Voltage at PCC	Individual Voltage Distortion (%)	Total Voltage Distortion THD (%)
69 kV and below	3.0	5.0
69.001 kV through 161 kV	1.5	2.5
161.001 kV and above	1.0	1.5

**Ieee std-519-for voltage distortion[]**

**3.3.3 Total Harmonic Distortion (THD):**

Ratio of the r.m.s. value of the sum of all the harmonic components of an alternating quantity up to a specified order (H), to the r.m.s. value of the fundamental component.: [9]

$$\text{THD} = \sqrt{\sum_{h=2}^H \left(\frac{Q_h}{Q_1}\right)^2}$$

### 3.3.4 Individual Harmonic Distortion (IHD):

Individual Harmonic Distortion (IHD) simply calculates the ratio of a given harmonic component to the fundamental component. This value is sometimes used to track the effect of each individual harmonic and examine its magnitude.

### 3.3.5 Fourier Series and Coefficients

Where

$a_0 = \frac{1}{T} \int_0^T f(t) dt$  (By definition, a periodic function,  $f(t)$ , is that where  $f(t) = f(t + T)$ ).

This function can be represented by a trigonometric series of elements consisting of a DC component and other elements with frequencies comprising the fundamental component and its integer multiple frequencies [2]. This applies if the following so-called Dirichlet conditions are met:

If a discontinuous function,  $f(t)$  has a finite number of discontinuities over the period  $T$ :

If  $f(t)$  has a finite mean value over the period  $T$

If  $f(t)$  has a finite number of positive and negative maximum values

The expression for the trigonometric series  $f(t)$  is as follows:

$$f(t) = \frac{a_0}{2} + \sum_{h=1}^{\infty} [a_h \cos(h\omega_0 t) + b_h \sin(h\omega_0 t)]$$

hence

$f(t) \equiv$  Discontinuous Function

$a_0 \equiv$  The Average Value of the Function  $f(t)$

$a_h, b_h \equiv$  The Coefficients of the Series, are the Rectangular Components of the  $n$ th Harmonic

$$\omega_0 = 2\pi / T$$

We can further simplify Equation (2.5), which yields:

$$f(t) = c_0 + \sum_{h=1}^{\infty} c_h \sin(h\omega_0 t + \phi_h)$$

( $a h^2 + b h^2$ ), and  $\phi_h = \tan^{-1}(a h / b h)$

Hence

$(h\omega_0) \equiv$  Hth Order Harmonic of the Periodic Function

$c_0 \equiv$  Magnitude of the DC Component

$C_h \equiv$  and  $\phi_h$  Magnitude and Phase Angle of the hth Harmonic Component

Equation (2.6) is known as a Fourier series and it describes a periodic function made up of the contribution of sinusoidal functions of different frequencies.

phase angle of each harmonic determine the resultant waveform  $f(t)$ .

Equation (2.5) can be represented in a complex form as:

$$f(t) = \sum_{h=1}^{\infty} c_h * e^{ih\omega_0 t}$$

(2.7)

where  $h = 0, \pm 1, \pm 2, \dots$

$$C_H = 1/T \int_{-T/2}^{T/2} f(t) e^{-i\omega_0 t} dt$$

Generally, the frequencies of interest for harmonic analysis include up to the 40th or so harmonics.

The main source of harmonics in power systems is the static power converter. Under ideal operation conditions [2], harmonics generated by a  $p$  pulse power converter are characterized by:

$$I_H = I_1 \div h$$

when  $h = pn \pm 1$

where

$h \equiv$  Stands for the Characteristic Harmonics of the Load;  $n = 1, 2, \dots$ ; and  $p$  is an Integer Multiple of Six.

### 3.3.6 TIF Weighting Factor:

The TIF weighting is a combination of the C message weighting characteristic, which accounts for the relative interfering effect of various frequencies in

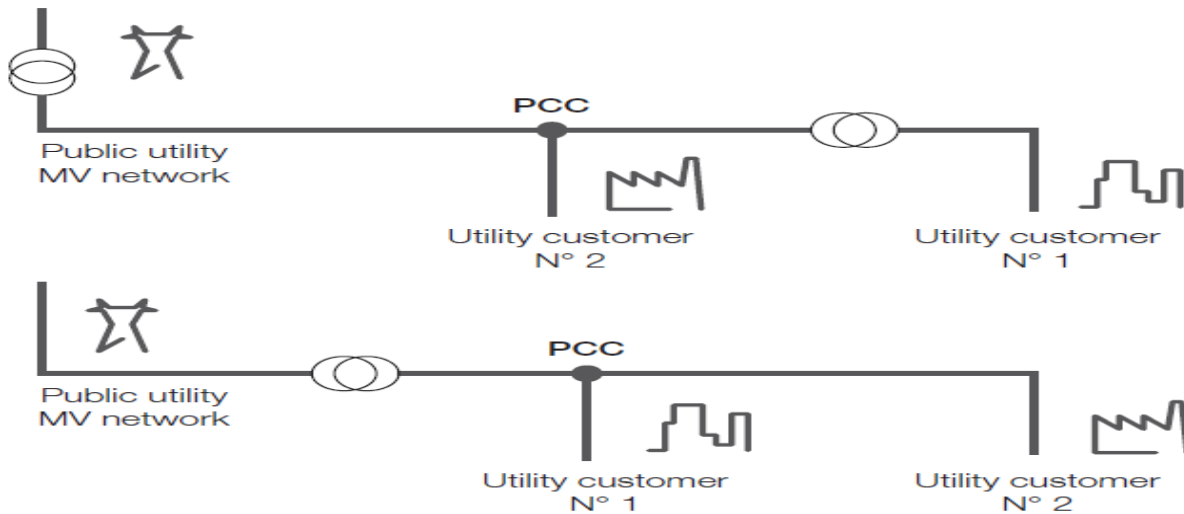
the voice band (including the response of the telephone set and the ear), and a capacitor, which provides weighting that is directly proportional to frequency to account for the assumed coupling function. TIF is a dimensionless quantity that is indicative of the waveform and not the amplitude and is given by

'Reprinted with permission from the Canadian Electric Association.

$$TIF = \frac{\sqrt{\sum (I_f \cdot W_f)^2}}{X_t}$$

### 3.3.7 Point of common coupling (pcc):

Evaluation of harmonic distortion are usually performed at a point between the end user or customer and the utility system where another customer can be served . this point is known as the point of common coupling .as shown in figure 3-1

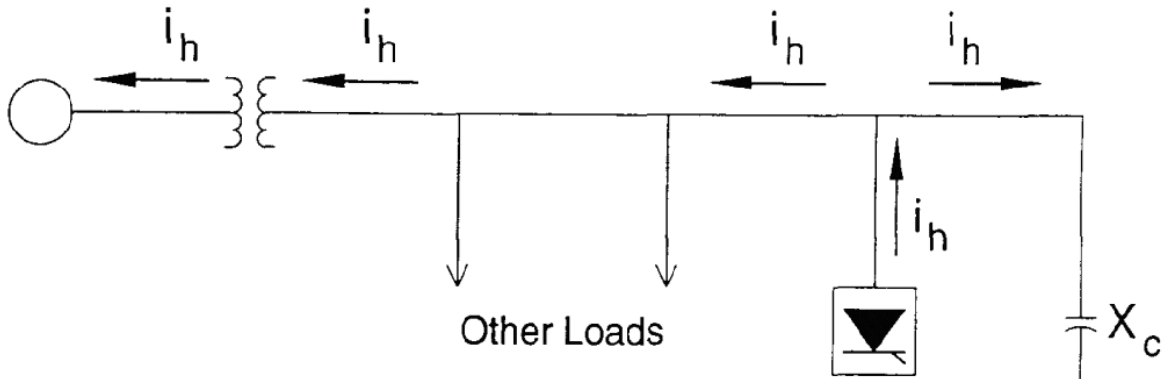


**Figure 3-1: Location of the point of common coupling**

### 3.4 Normal Flow of Harmonic Currents

Harmonic currents tend to flow from the nonlinear loads (harmonic sources) toward the lowest impedance, usually the utility source (see Fig 5.1). The impedance of the utility source is usually much lower than parallel paths

offered by loads. However, the harmonic current will split depending on the impedance ratios. Higher harmonics will flow to capacitors that are a low impedance to high frequencies.



**Figure 3.2 Normal flow of harmonic current**

### **3.5 Source of harmonic:**

#### **3.5.1 Sources of Harmonics:**

The generation of harmonics in power system occurs from two distinct types of loads:

##### **3.5.1.1 Linear Loads:**

These loads display constant steady-state impedance during the applied sinusoidal voltage. As an example transformers and rotating machines, under normal loading conditions. [2]

##### **a - Transformer:**

Harmonics in transformers originate as a result of saturation, switching, high-flux densities, and winding connections where: [2, 8]

i- Triple Harmonics generated on the neutral conductor in the Star- Connected Transformers.

ii- Triple harmonics occur in magnetization currents but they cannot get out of the delta connected coils. Other harmonic components pass to the network side in the Delta-Connected Transformers.

Because of an economic reasons the transformer are operated in the knee point of saturation but when the amplitude of the voltage is large enough to enter the nonlinear region of the B-H curve, the magnetizing current needed will greatly distorted from sinusoidal current and contain harmonics as shown in figure 2.2



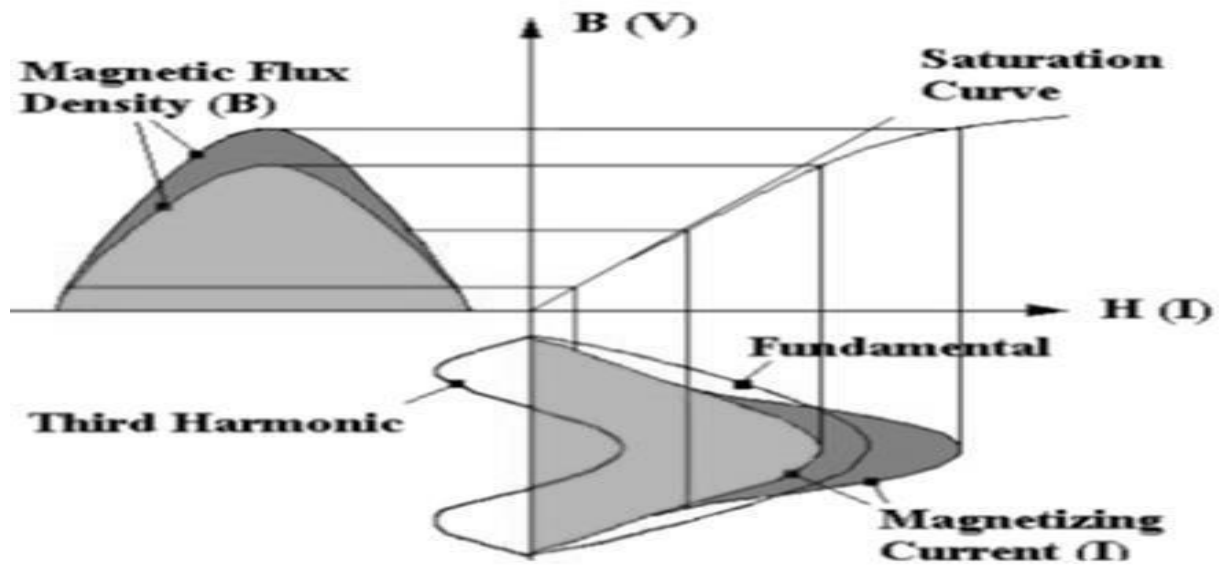
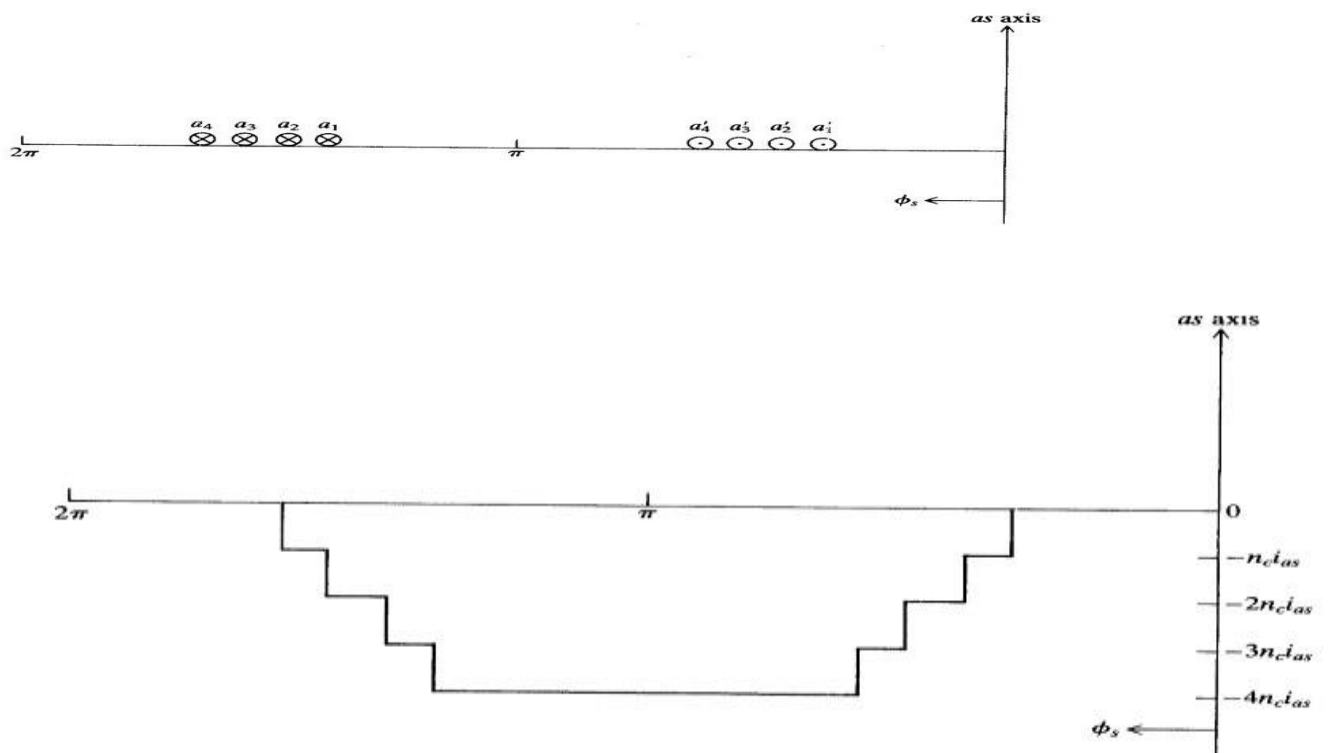


Figure 3-3: Transformer magnetizing current curve

**b- Rotating machines:**

Produce harmonics due to the field distribution of salient poles figure (2.3), slots and the saturation of the main circuit. [2, 8]



**Figure 3.4: non sinusoidal field distribution of rotating machines.**

**3.5.1.2 Nonlinear Loads:**

These loads do not exhibit constant impedance during the entire cycle of applied sinusoidal voltage. Some examples of nonlinear loads are:

- Arc furnaces.
- Variable frequency drivers.
- Uninterrupted power supply.(UPS)
- Computers, copy machines, and television sets.
- Fluorescent lighting and electronic ballasts. [1, 4]

**A- Arc furnaces**

The cause of harmonics on an arc furnaces is mainly related to the non-linear voltage-current characteristic of the arc while the voltage fluctuations are due to the arc length changes that occur during the melting of the scrap. Figure 3.5 Show the voltage-current characteristics and figure 3.6 and show the waves produced from an arc furnace. [2, 5]

Table 3.3 harmonic current of the arc furnances

Furnace Condition	Harmonic Order in %					
	1	2	3	4	5	7
Initial Melting	100	7.7	5.8	2.5	4.2	3.1
Refining	100	-	2.0	-	2.1	-

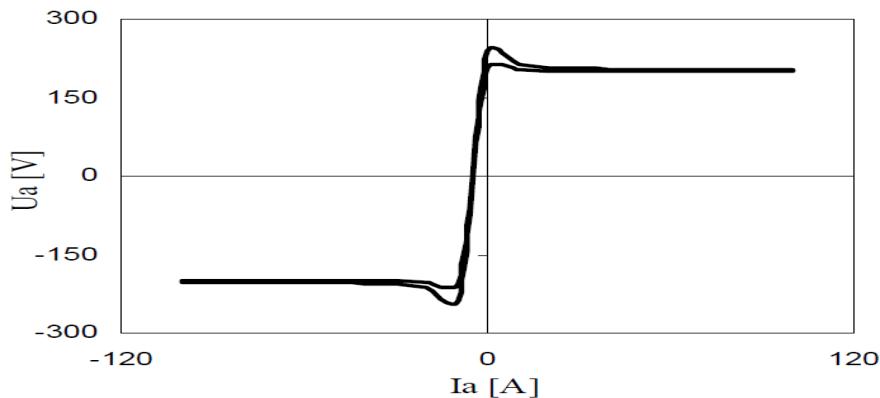


Figure 3.5 Voltage-current characteristics

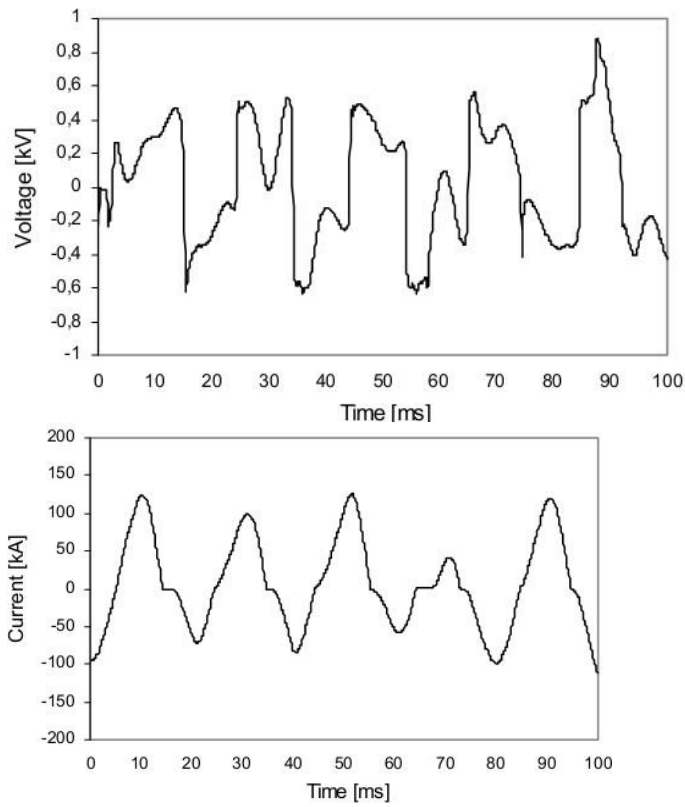


Figure 3-6: Voltage and current waveforms of an arc furnace.

$V_h$  = harmonic component of voltage of the order indicated by the subscript

$$V_H = \sqrt{\sum_2^{\infty} V_h^2}$$

$$\text{TIF} = \sqrt{\sum \left[ \frac{(X_f \cdot W_f)}{X_t} \right]^2}$$

where

$X_t$  = total r.m.s voltage or current

$X_f$

$W_f$  = single frequency TIF weighting at frequency  $f$

= single frequency rms current or voltage at frequency  $f$

The TIF weighting function,  $Wf$ , which reflects the present C message weighting and the

coupling (proportionality component) normalized to 1 kHz, is given by

$$Wf = 5Pf \quad (\text{Eq 6.3})$$

where

$5$  = constant

$Pf$  = C message weighting at frequency  $f$

$f$  = frequency under consideration

## B- Variable frequency drives (VFD)

VFDs are, in reality, power converters. The reason to further address them under a separate section is because, by themselves, VFDs constitute a broad area of application used in diverse and multiple industrial processes.

In a very general context, two types of VFDs can be distinguished, those that rectify AC power and convert it back into AC power at variable frequency and those that rectify AC power and directly feed it to DC motors in a number of industrial applications. In both cases, the front-end rectifier, which can make use of diodes, thyristors, IGBTs, or any other semiconductor switch, carry out the commutation process in which current is transferred from one phase to the other. This demand of current “in slices” produces significant current distortion and voltage notching right on the source side, i.e., at the point of common coupling (pcc). Motor speed variations, which are achieved through firing angle control, will provide different levels of harmonic content on the current and voltage waveforms. Variable frequency drive designs also determine where harmonic currents will predominantly have an impact. For example, voltage source inverters produce complex waveforms showing significant harmonic distortion on the voltage and less on the current waveforms. On the other hand, current source inverters produce current waveforms with considerable harmonic contents with voltage waveforms closer to sinusoidal. None of the drive systems is expected to show large distortion on both voltage and current waveforms, in line with Finney’s observations. Regarding VFDs, the ABB ACS6000 6P has been taken into account as it is available in ETAP harmonics library. [9]

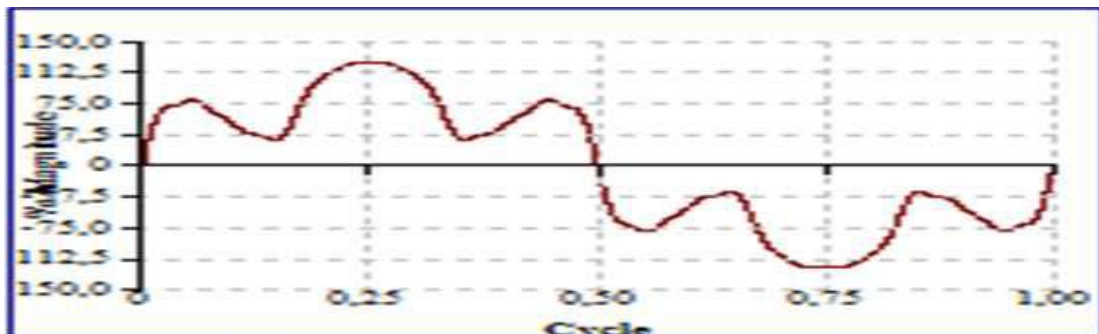


Figure 3.7 : Harmonic Source waveform for VFD



Figure 3.8: Harmonic Source Spectrum for VFD

### C-Uninterruptible power supply systems (UPS)

Uninterruptible power supply systems are usually used to provide “secure power” in the event of generator shutdown or other similar power failure.

Dedicated individual computer UPS systems are usually singlephase and have an input current wave-shape and harmonic currentspectrum similar to that produced by single-phase switched mode powersupplies (SMPS). Three-phase UPS systems are also available.

The majority of three-phase UPS systems have a controlled, SCR input bridge rectifier with characteristic harmonics based on the “pulse number  $\pm 1$ ” format. An IEEE standard spectrum as been considered for UPS devices due to the fact that no supplier information is available at project early stages.[9]

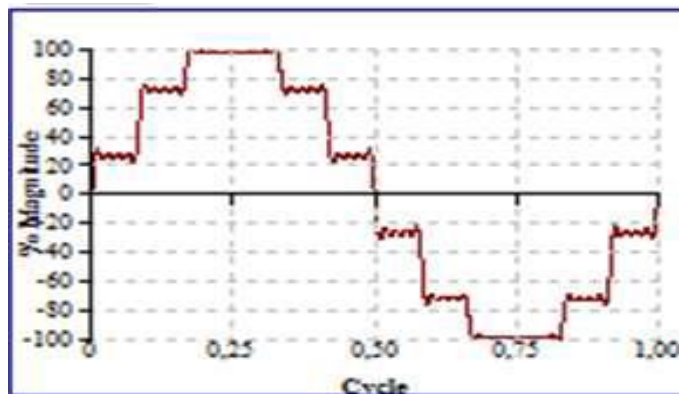


Figure 3.9: Harmonic Source waveform for UPS



Figure 3.10 : Harmonic Source Spectrum for UPS

### D-The rectifier

The rectifier can be thought of as a harmonic current source and produces roughly the same amount of harmonic current over a wide range of power system impedances. The characteristic current harmonics that are produced by a rectifier are determined by the pulse number.

The following equation allows determination of the characteristic harmonics for a given pulse number:

$$h = k q \pm 1 \quad (3.1)$$

where

$h$  is the Harmonic Number (Integer Multiple of the Fundamental)

$k$  is Any Positive Integer

$q$  is The Pulse Number of the Converter

This means that a 6-pulse (or 3-phase) rectifier will exhibit harmonics at the 5th, 7th, 11th, 13th, 17th, 19th, 23rd, 25th, etc. multiples of the fundamental. As a rough rule of thumb, the magnitudes of the harmonic currents will be the fundamental current divided by the harmonic number (e.g. the magnitude of the 5th harmonic would be about 1/5th of the fundamental current).

A 12-pulse (or 6-phase rectifier) will, in theory, produce harmonic currents at the 11th, 13th, 23rd, 25th, etc. multiples. In reality, a small amount of the 5th, 7th, 17th and 19th harmonics will be present with a 12-pulse system (typically the magnitudes will be on the order of about 10 percent of those for a 6-pulse drive). []

### E- Fluorescent lighting

Lighting typically accounts for 40 to 60 percent of a commercial building load. Fluorescent lights are discharge lamps; thus they require a ballast to provide a high initial voltage to initiate the

discharge for the electric current to flow between two electrodes in the fluorescent tube. Once the discharge is established, the voltage decreases as the arc current increases. It is essentially a short circuit between the two electrodes, and the ballast has to quickly reduce the current to a level to maintain the specified lumen output. Thus, a ballast is also a current limiting device in lighting applications. There are two types of ballasts, magnetic and electronic. The iron-core magnetic ballast contributes additional heat losses, which makes it inefficient compared to an electronic ballast. An electronic ballast employs a switch-mode-type power supply to convert the incoming fundamental frequency voltage to a much higher frequency voltage typically in the range of 25 to 40 kHz. This high frequency has two advantages. First, a small inductor is sufficient to limit the arc current. Second, the high frequency eliminates or greatly reduces the 100- or 120-Hz flicker associated with an iron-core magnetic ballast. [electrical power system quality] .[6

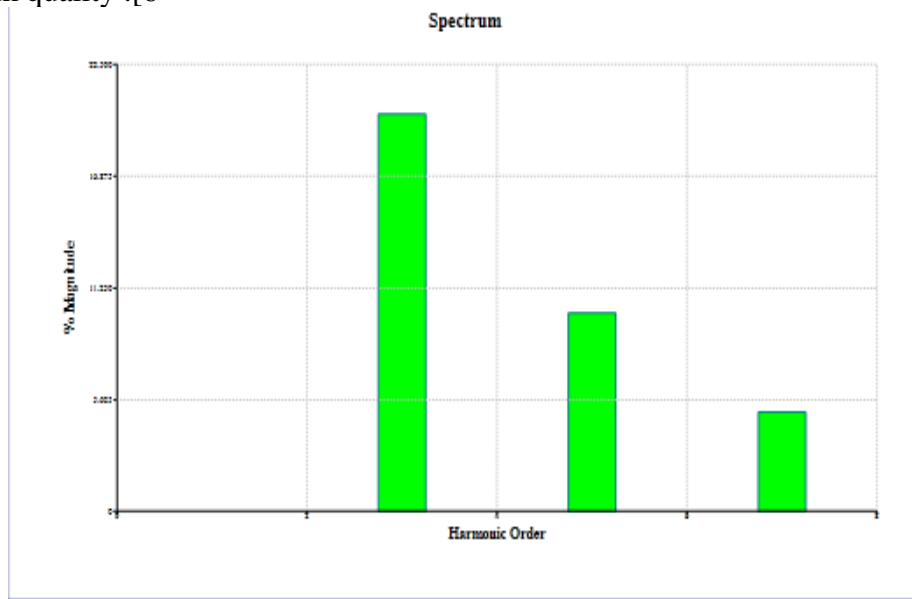


Figure 3.11 harmonic spectra of fluorescent lamp for phase current

### F- Switched mode power supplies

In all personal computers, the switched mode power supplies are used. These are very economical designs in which energy stored in a capacitor and discharged in order to get a dc voltage through an electronic circuit. Since the load seen by the ac side is capacitive, the current flow is not continuous. The typical harmonic components due to a switched mode power supply are shown in Table 3.4 [1].

table 3.4 harmonic content of a Switched power supply:

Harmonic Order	Amplitude, %	Harmonic Order	Amplitude, %
1	100	3	81.0
5	60.6	7	37.0
9	15.7	11	2.40
13	6.30	15	7.90

#### **G- Pulse Width Modulated (PWM) converters**

PWM converters use power Electronic devices that can be turned on and turned off. The input power is usually obtained from a converter source and the output voltage is shaped as per the requirement using thyristor switching. The output pulse widths are varied to obtain a three-phase voltage wave at the load. The load is usually ac motors used as variable speed drives. The harmonic contents due to a typical PWM drive at various load conditions are listed in Table 3.4 [1].

Table 3-4 Harmonic content of PSW



h order	100% Load		75% Load		50% Load	
	Mag.	Angle	Mag.	Angle	Mag.	Angle
1	100.	0	100.	0	100.	0
3	0.35	-159	0.59	-44	0.54	-96
5	60.82	-175	69.75	-174	75.09	-174
7	33.42	-172	47.03	-171	54.61	-171
9	0.5	158	0.32	-96	0.24	-102
11	3.84	166	6.86	17	14.65	16
13	7.74	-177	4.52	-178	1.95	71
15	0.41	135	0.37	-124	0.32	28
17	1.27	32	7.56	9	9.61	10
19	1.54	179	3.81	9	7.66	16
21	0.32	110	0.43	-163	0.43	95
23	1.08	38	2.59	11	0.94	-8
25	0.16	49	3.70	10	3.78	7

### 3.6 Effect of Harmonic:

#### 3.6.1 Motors and Generators:

–Increased heating due to iron and copper losses:

Similar to transformers, rotating machines are exposed to thermal effects from harmonics. Because the effective resistance of a conductor goes up as frequency rises, a current wave rich in harmonics may cause greater heating on winding conductors than a sine wave of the same rms value

.- Reduced efficiency and torque

- Higher audible noise

- Cogging or crawling

-Mechanical oscillations

### **3.6.2 Transformers:**

It should be noted that the transformer losses caused by both harmonic voltages and harmonic currents are frequency dependent. The losses increase with increasing frequency and, therefore, higher frequency harmonic components can be more important than lower frequency components in causing transformer heating. In general, the steady state: 5% at rated load and 10% at no load. The harmonic currents in the applied voltage must not result in a total rms voltage exceeding these ratings. The major effects of transformers are :

-Parasitic heating

A particular aspect of transformers is that, under saturation conditions, they become a source of harmonics. Delta-wye- or delta-delta-connected transformers trap zero sequence currents that would otherwise overheat neutral conductors. The circulating currents in the delta increase the rms value of the current and produce additional heat. This is an important aspect to watch. Currents measured on the high-voltage side of a delta-connected transformer will not reflect the zero sequence currents but their effect in producing heat losses is there. This heat can have a significant impact in reducing the operating life of the transformer insulation

-Increased copper, stray flux and iron losses

### **3.6.3 Capacitors (var compensators):**

The limit of the harmonic of svc shown in the table 3-5

Table 3-5 maximum harmonic amplitude due to svc :

Harmonic Order	Amplitude, %	Harmonic Order	Amplitude, %
1	100	3	13.78
5	5.05	7	2.59
9	1.57	11	1.05
13	0.75	15	0.57
17	0.44	19	0.35
21	0.29	23	0.24
25	0.20		

**-Resonant conditions:**

Resonant conditions involve the reactance of a capacitor bank that at some point in frequency equals the inductive reactance of the distribution system, which has an opposite polarity. This condition may produce a large overvoltage between the parallel-connected elements, even under small harmonic currents. Therefore, resonant conditions may represent a hazard for solid insulation in cables and transformer windings and for the capacitor bank and their protective devices as well.

**-Unexpected fuse operation:**

As mentioned earlier, rms voltage and current values may increase under harmonic distortion. This can produce undesired operation of fuses in capacitor banks or in laterals feeding industrial facilities that operate large nonlinear loads.

**- Abnormal operation of electronic relays:**

Most relays monitor and measure the current (or voltage) amplitude, the distorted waveform can affect the relay's operation and result in power system reliability reducing and system damage. Most of the literatures reveal that the performance of relays in presence of harmonics is not significantly affected when the total harmonic distortion (THD) is less than 20%. Overcurrent relays have to operate with current transformers (CT) which may saturate and distort the current waveform causing a malfunction to the over current relays [11].

**3.6.4 Switchgears:**

- Increased heating and losses
- Reduced steady-state current carrying capability
- Shortened insulation of components life.

**3.6.5 Metering:**

Affected readings

**3.6.6 Power Cables:**

- Involved in system resonance
- Voltage stress and corona

-Leading to dielectric failure-Heating and derating

### **3.6.7 Neutrals of four-wire systems (480/277V; 120/208V)**

-Overheating

### **3.6.8 Fuses:**

-Blowing

### **3.6.9 Communication Systems**

-Interference by higher frequency electromagnetic field

### **3.6.10 Electronic Equipment (computers, PLC)**

-Misoperation

### **3.6.11 System**

-Resonance (series and parallel)

- Poor power factor [5]

## **3.7 Harmonic Mitigation Techniques:**

### **3.7.1 Introduction:**

With the increase in consumer nonlinear loads, the harmonics injected into the power supply system and their consequent effects are becoming of greater concern. Efforts are done to reduce these problems by suggesting many solutions such as:

I- The equipment can be designed to withstand the effect of harmonics, e.g. transformers, cables, and motors can be de-rated.

II- Passive filters at suitable locations preferably close to the source of harmonic generation can be provided so that the harmonic currents are trapped at the source and the currents propagated in the system are reduced.

III- Active filtering techniques, generally, incorporated with the harmonic producing equipment itself can reduce the harmonic generation at source.

Hybrid combinations of active and passive filters are also a possibility.

IV- Alternative technologies can be adopted to limit the harmonics at source, e.g. phase-locked loop (PLL) based active filters.

And one of the most common methods for control of harmonic distortion in industry is the use of passive filtering techniques that make use of single-tuned or band-pass filters. In this chapter we only take one method to discuss all the methods of harmonic mitigation in industrial power systems. [1, 2, 5]

Generally, for three-phase system the well-known harmonic mitigation techniques are: Reducing the overall line current THDi to maintain the current

sinusoidal waveform characteristics is the major role of these harmonic mitigation methods.

### 3.8 HARMONIC FILTERS:

Filtering the dominant harmonics can reduce the effect of harmonics. There are several filters available to perform this function. The single tuned notch filter and the high pass filter are two commonly used devices [1-3].

#### 3.8.1 Passive Filters:

In passive harmonic filters, preventing the circulation of the unwanted harmonic currents in the power system can be achieved by the usage of a high series impedance to block them (series filter concept) or by diverting the harmonic currents to a low impedance shunt path (shunt filter concept). Series passive filters can be purely inductive type or LC tuned type. AC line reactor filter and DC-link inductor filter are the two purely inductive type filters. AC line reactors offer a considerable magnitude of inductance that alters the shape or form factor the current waveform drawn by the rectifier bridge.

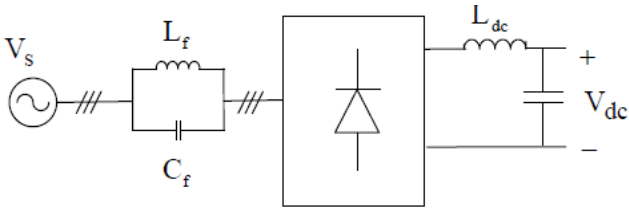


Figure 3.12: Tuned series Passive filter

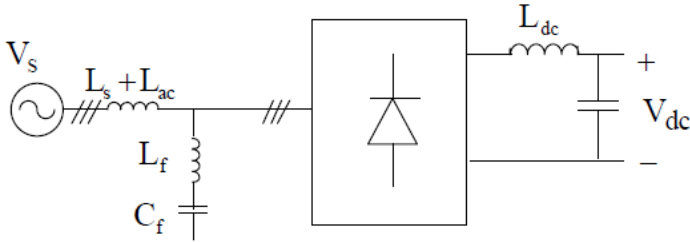


figure 3.13: Shunt passive filter type

The tuned series passive filter type is shown in Fig. 3.12. The filter consists of parallel inductance ( $L_f$ ) and capacitance ( $C_f$ ) that are tuned to provide high

impedance at a selected harmonic frequency. The high impedance then attenuates the flow of harmonic current at the tuned frequency only.

In practice the tuned filters are employed for at most a few dominant harmonics. Filtering must begin with the highest harmonic frequency to be filtered and the utilization of the filters for the lower frequency harmonics is necessary to avoid parallel resonance related over-voltages at the lower harmonic frequency. Therefore, filtering the dominant 7th harmonic would require a 7th harmonic filter along with the 5th harmonic filter.

**Single tuned filters** - A single tuned or a notch filter can be used to filter harmonics at a particular frequency. illustrates a common single tuned notch filter to control a single harmonic. The impedance characteristics of the filter are also shown in Figure 8.4. The following variables are used to describe the filter.

$$MVAR_c = \frac{kV^2}{X_c}$$

$$f_0 = \frac{1}{2\pi\sqrt{LC}}$$

$$Q = \frac{X_c}{R}$$

Where  $MVAR_c$  = Rating of the filter bank

$X_c$  = Reactance of the inductor

$f_0$  = Resonant frequency of the filter

$Q$  = Q factor (typical value of 20 to 150)

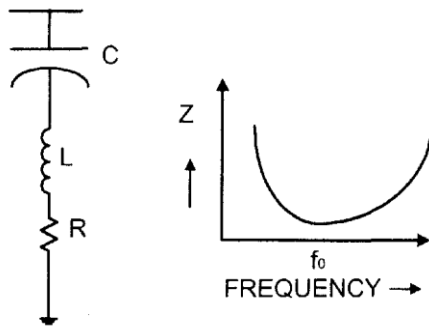


Figure 3-14 Single Tuned Filter With Frequency Response Characteristics

The tuned frequency and the operating point may change due to temperature, tolerances and change in the supply frequency. But the single tuned filter is the simplest device for harmonic control.

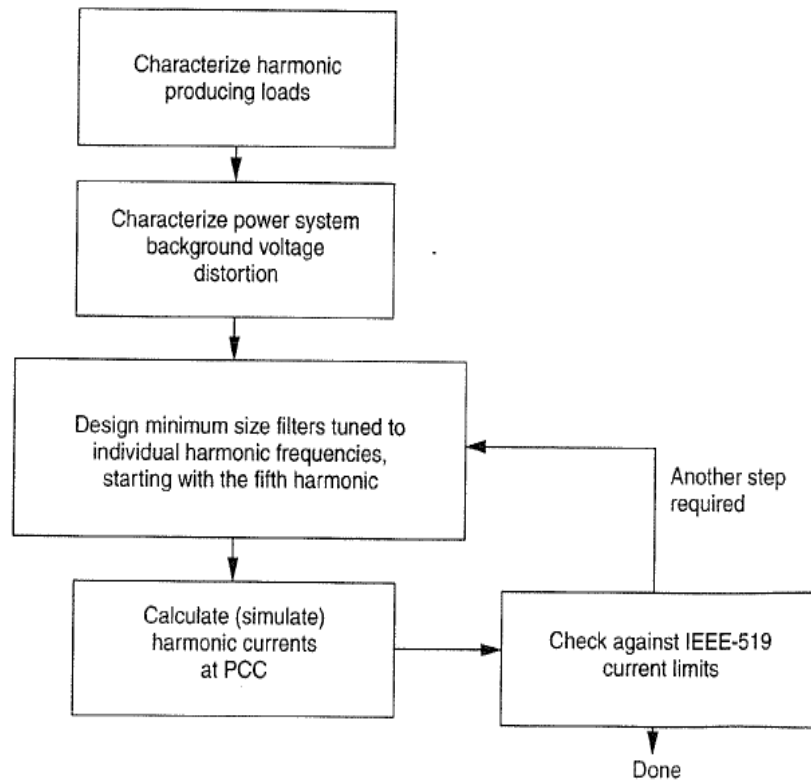


Figure 3.15: General procedures for designing individually tuned filter steps for harmonic control

**\* Phase Multiplication Systems:**

Phase multiplication technique is based on increasing the pulse number for the converter. This increases the lowest harmonic order for the converter and reduces the size of the passive filter needed to filter out the current harmonics.

**3.8.2 Active Harmonic Compensation Systems:**

Active harmonic compensation (filtering) method is relatively a new method for eliminating current harmonics from the line. Active filters give good system performance and current harmonics reduction. They are more adaptive, maintain good harmonic attention and line power factor correction across a wide range of

rectifier load current. However, they are based on sophisticated power electronics systems and thus they are much more expensive than passive filters [10], [12] and are still avoided in most applications due to their high cost and complexity.

In active filters the basic idea is to inject to the line equal magnitudes of the current/voltage harmonics generated by the nonlinear load and with 180 degrees phase angle difference so they cancel each other

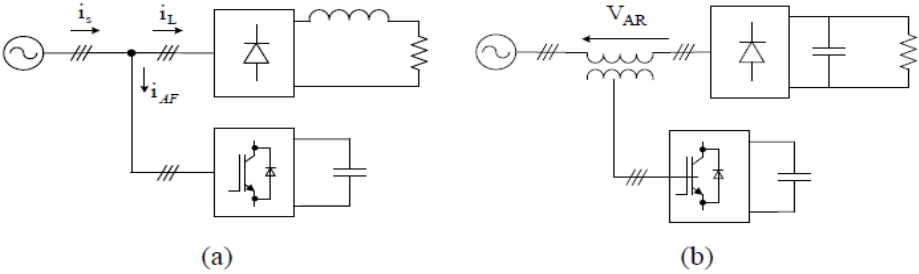


Figure 3.16: Active filter fundamental system configurations:

- (a) Shunt active filter
- (b) Series active filter



# CHAPTER FOUR

## Case study measurement and results

### 4.1 Information about the Substation:

The Sudanese electricity distribution company represents the operation of overall power system in the sudan including substation . The research is compromised of studding information from EL OUMERA SUBSTATION which fed from (2\*15MVA) power transformers and two capacitor banks with 4.5MVar capacity for each section. The basic data of the overall system are given in appendix(A).

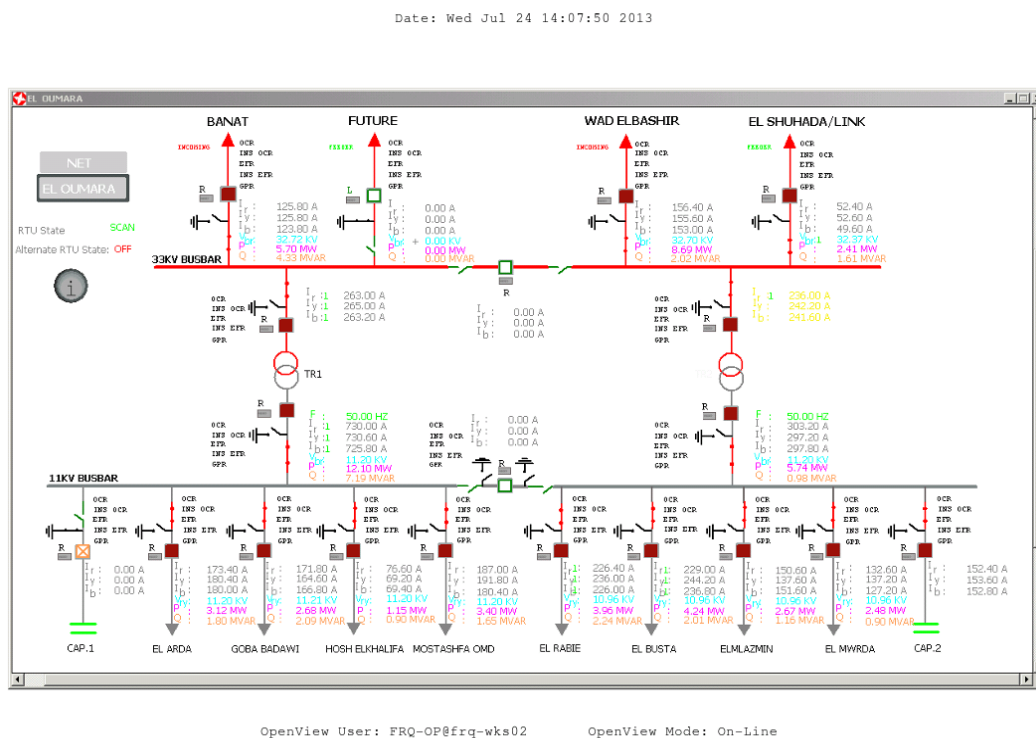


Figure 4-1: Single line diagram of EL OUMERA substation

## Case Study (System Analysis):

This section shows the power flow solution of the system, solved using the ETAP12.6 Newton- Raphson algorithm which includes the PF, load current, in this study the targeted bus is bus 5 and transformer (TR-2). Load flow analysis and harmonic load flow of the system had been carried out by Etap 12.6 and the following three scenarios were applied:

Without capacitor bank.

With capacitor bank.

With capacitor bank and single tuned filter.

Etap software program:

It is a true 64 bit program developed for the Microsoft® Windows® 2008 R2 (SP1), 2012/R2, 7 (SP1), 8/8.1, 10 operating systems. This demo is fully interactive and allows you to make changes to the one-line diagram, run system studies, and graphically review study results - just like the full, commercial release of the program. It gives you the opportunity to explore the many features and capabilities of ETAP including Arc Flash, Load Flow, and AC/DC Short-Circuit (Refer to the demo restrictions document for a full list of capabilities).

PWS 2.3 device:

The PWS 2.3 genX Portable Working Standard is a three-phase portable electronic meter test unit of accuracy class 0.1%, used for testing single and three-phase electricity meters on site. The PWS 2.3 genX allows checking of all meter installation parameters and associated circuits. The unit can be used either with a direct connection in the range of 1 mA ... 12 A, or by using a set of 3 active 120 A error compensated UCT clamp-on CT's (included in the standard accessories set) in the range 10 mA ... 120 A. It is therefore possible to easily and accurately measure both CT and direct connected meters.

The unit can be powered either from the measuring circuit or from an auxiliary single-phase supply.

**Advantages:**

- a- Large 7” (800 x 480 pixels) TFT touch screen color display with graphical user interface
- b- Data transfer and communication via USB (Type B), ETHERNET or WLAN
- c- Built in web server for remote display of graphical user interface and remote control of the unit
- d- Data storage on removable SD memory card
- e- Independent sets of UCT clamp-on CTs allow service, calibration or later purchase of UCT clamp-on CTs without factory return of the device.

**i-Scenario 1(Load flow analysis by ETAP without capacitor)**

The following result shown in tables (4.1, 4.2) represent the load flow result for first scenario.

Table 4.1: Load flow bus data

BUS ID	Nominal kV	Voltage %
Bus10	33	100
Bus11	33	100
Bus9	11	98.18
Bus5	11	94.02

Table 4.2: Load flow load data

ID	Rating	Rated kV	MW	Mvar
ELBOSTA	3696 Kva	11	3.180	3.610
EL RABEI	1943 Kva	11	2.936	2.579
EL MORDA	4592 kVA	11	4.169	3.094

1. Actual readings atsite:

Readings was taken from substation using portable Network Analyzer PWSat 8:00 pm because the price of the kwh at night is less than the morning for industrial load. The device show there is individual harmonic distortion order 5<sup>th</sup> With value 9.5 and the total harmonic distortion THDV are 11.3 AL BOSTA feeder 11kv . The device and wiring diagram are shown in figure 4.1 and figure 4.2.



Figure4.2:PortableNetworkAnalyzerPSW2.3

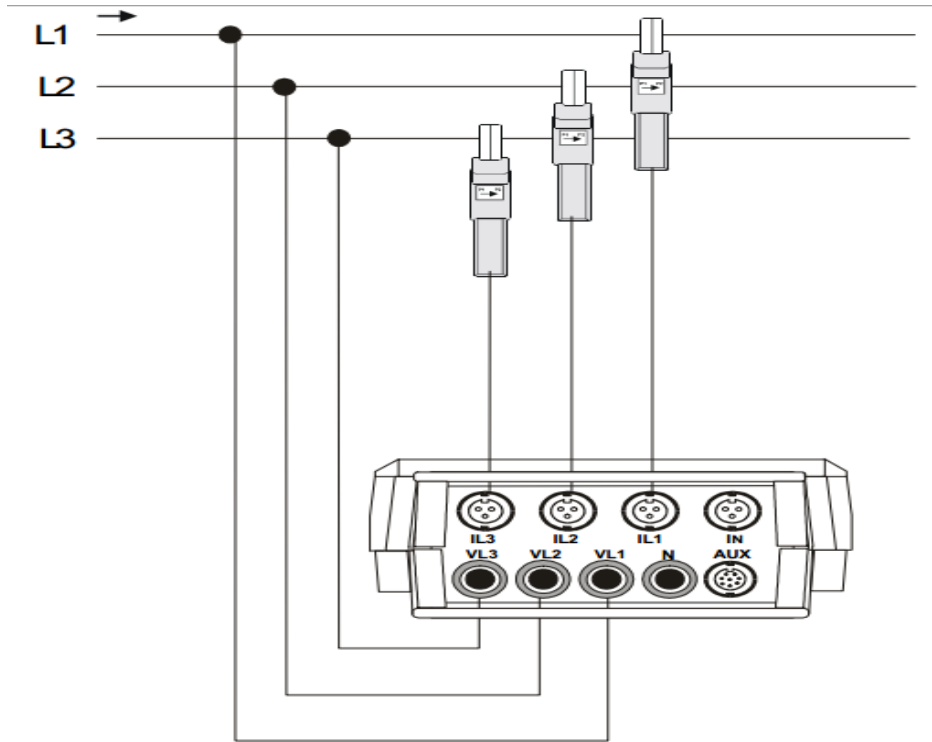


Figure 4.3: Connection diagram of PSW2.3 phase

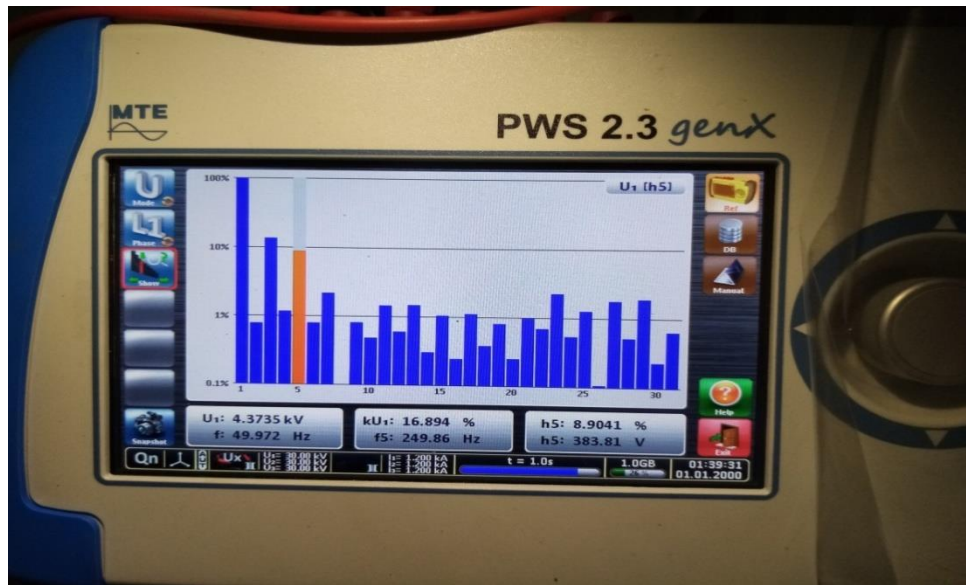


Figure4.4:ActualreadingfromPSW2.3

#### 4.3.2 Harmonic Analysis by ETAP:

This section presents the harmonic analysis of the system ,Newton Raphson algorithm which total harmonic distortion (THD),individual harmonic distortion (IHD) with an indication to which of them had exceed the limits referring to the IEEE519-1992standards.

I. First scenario results: Harmonic

II. load flow result without capacitorbank: Table5.4: VIHD (individual harmonic distortion report)

#### Bus Voltage Distortion

ID	KV	Fund %	VIHD %	Order
Bus 5	11.00		96.44 8.9	5

Indicates buses with IHD (Individual Harmonic Distortion) exceeding the limit

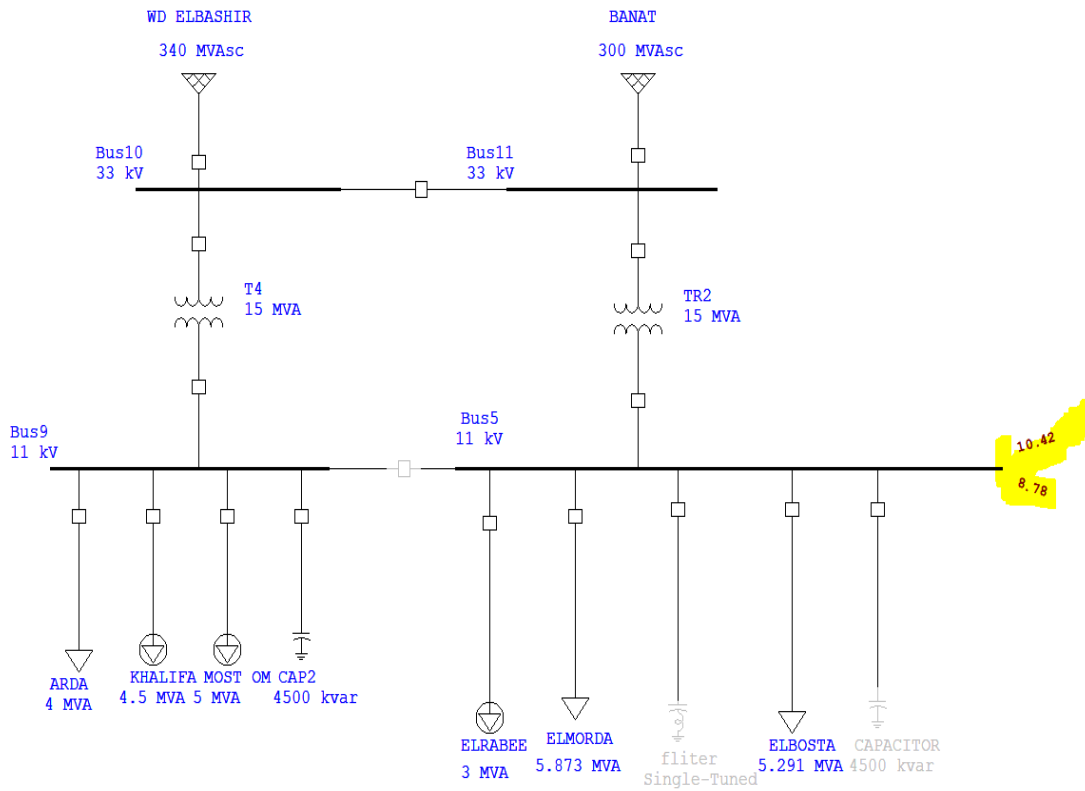


Figure 4.5 Indicates buses with THD (Individual Harmonic Distortion)

## 2-Discussion of scenario one result

It is clearly that there is significant total harmonic distortion (THD) at Bus 5

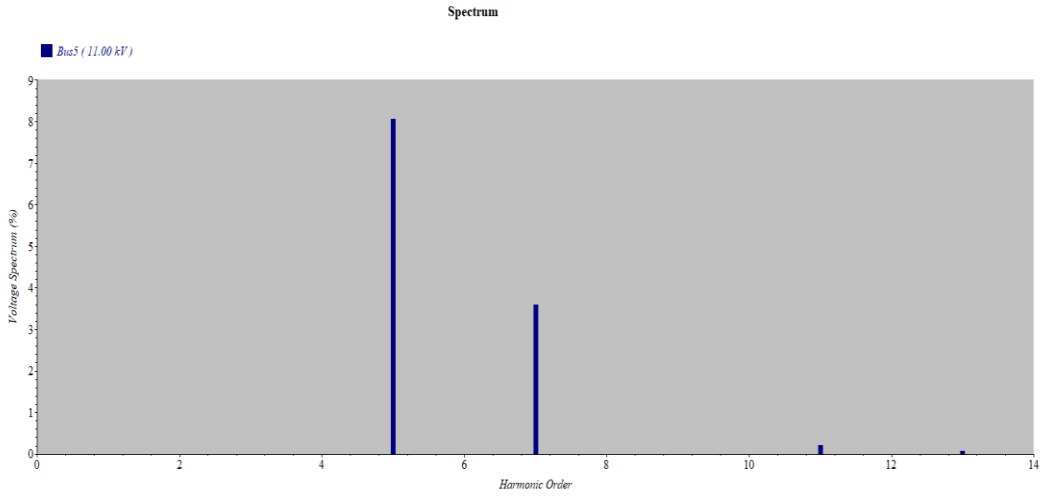


Figure4.6 Bus 5 spectrum

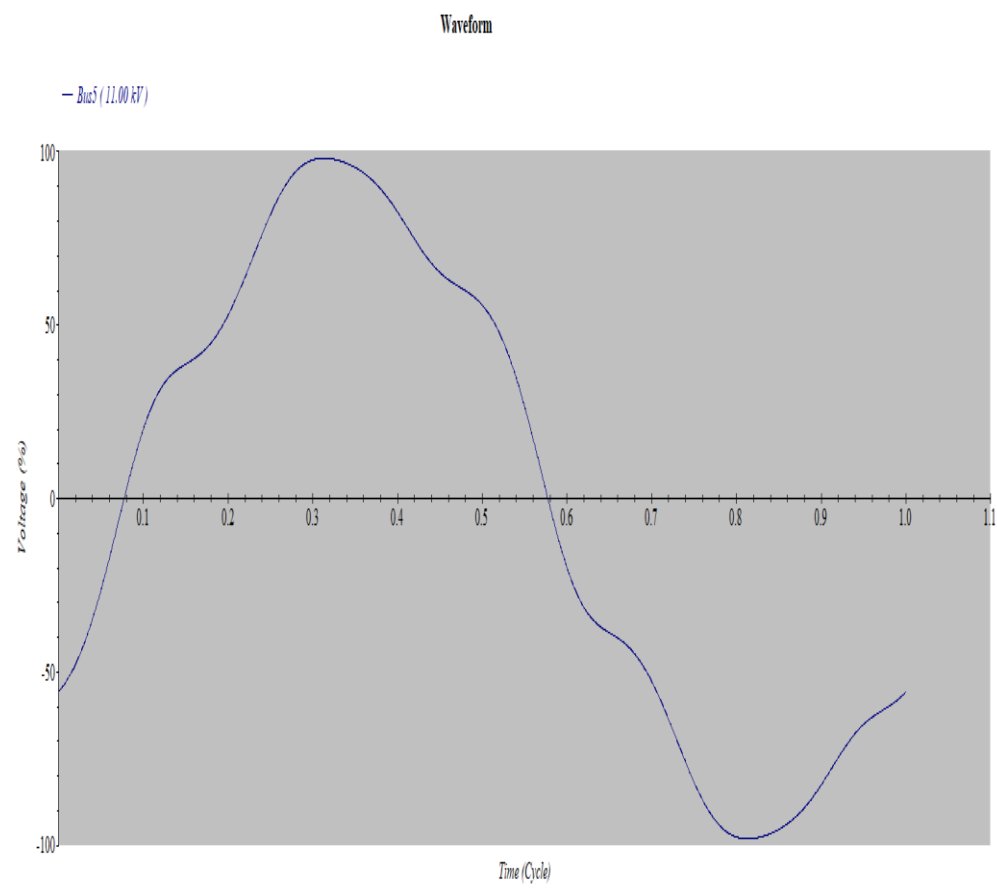


Figure4.7 Bus 5 wave form

II-Second scenario : Insertion of 4.5Mvar capacitor bank atbus4:



Tables 4.5 show the result of harmonic load flow for the second scenario

Table 4.5: VTHD (Total Harmonic Distortion) report

Bus		Voltage Distortion	
ID	KV	Fund. %	VTHD%
*Bus 5	11.00	94.02	8.9

\* Indicates buses with THD (Total Harmonic Distortion) exceeding the limit

: Discussion of scenario two:

Obviously after insertion of 4.5 Mvar capacitor bank at Bus 5 the total harmonic distortion (THD) of overall system increase dramatically as shown in figure (4.11) and this will effect of all equipment through the system specially on transformer and capacitor bank. Figures below show the harmonic voltage and current spectrum and their waveform for each element on Bus 4.

Voltage spectrum at bus 5:

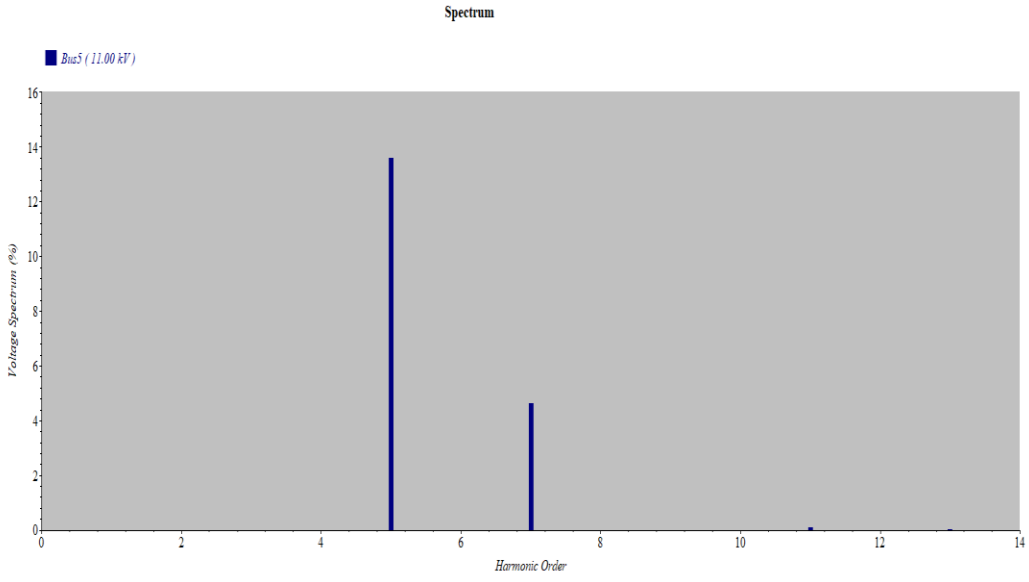


Figure 4.8: Voltage spectrum at Bus5

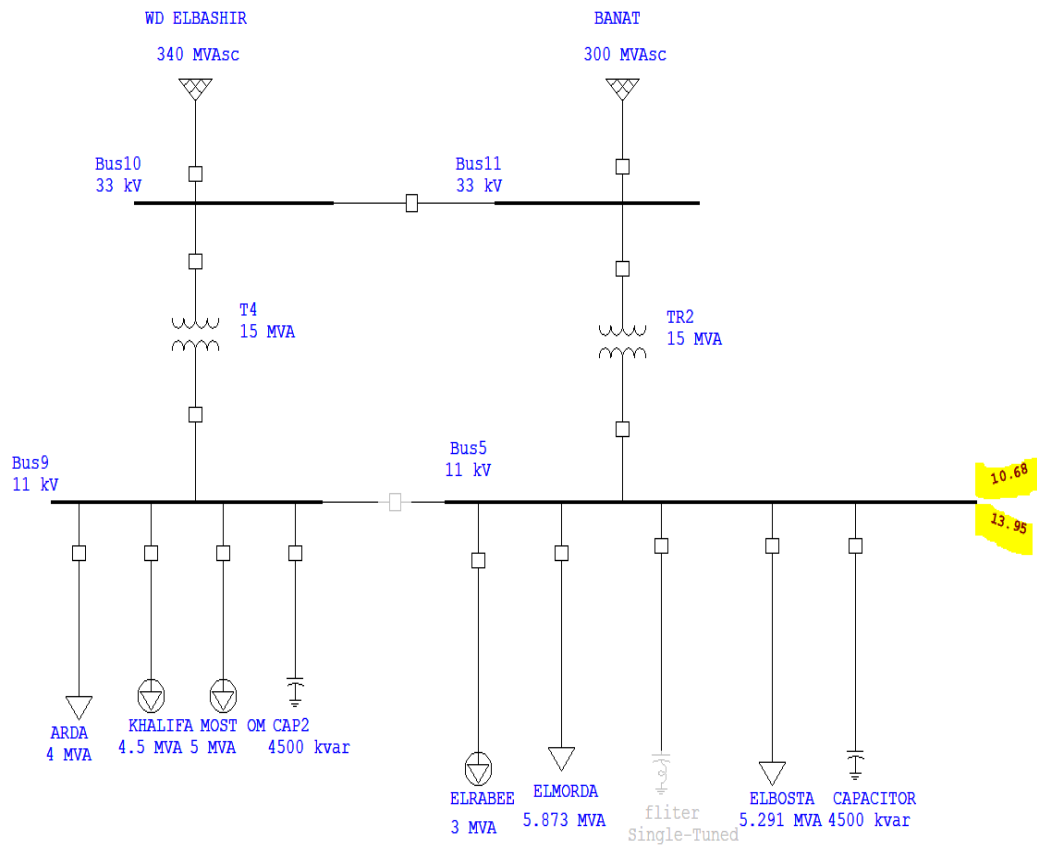


Figure 4.9: Overall system harmonic load flow result for the second scenario

### III-Third scenario : Insertion of single tuned filter at bus5:

Etap automatically sizing the filter and calculate filter parameter (steps details on reference []). Figure 4.12 show the results of third scenario.

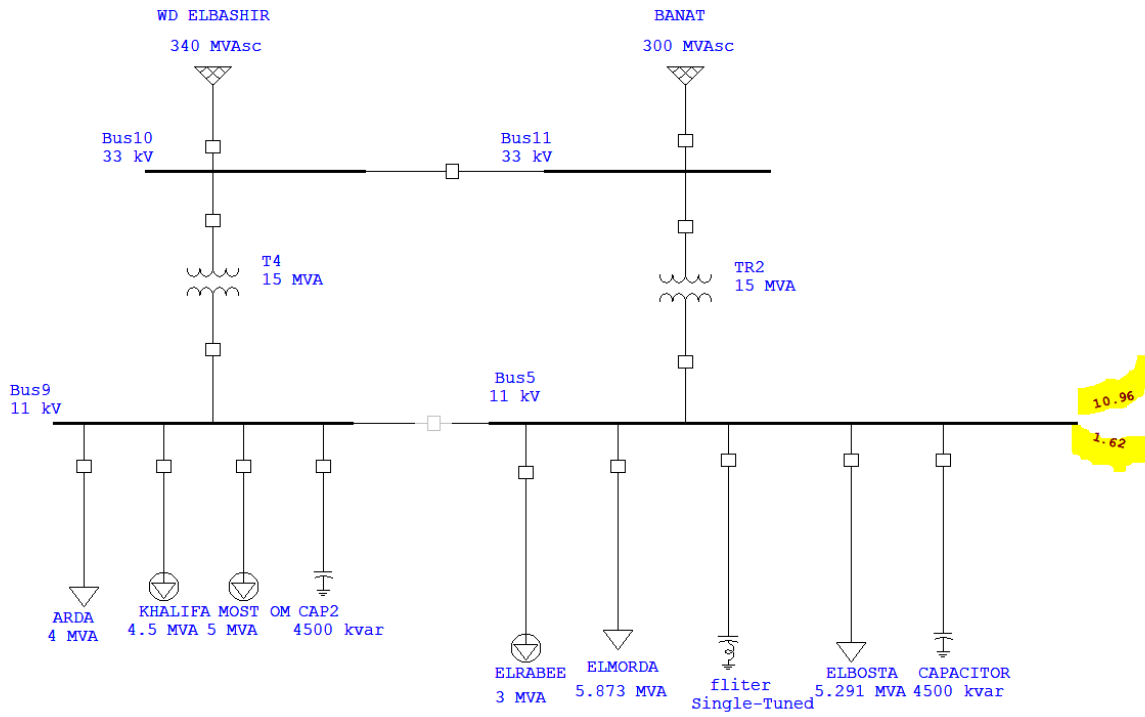


Figure 4.10: Overall system harmonic load flow result for the third scenario

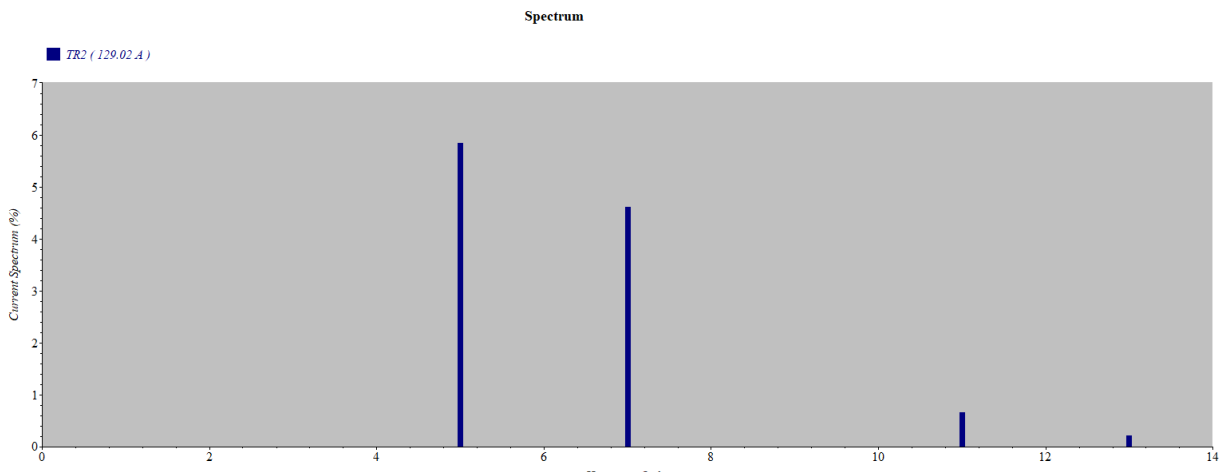


Figure4.11 Spectrum at fliter at transformer

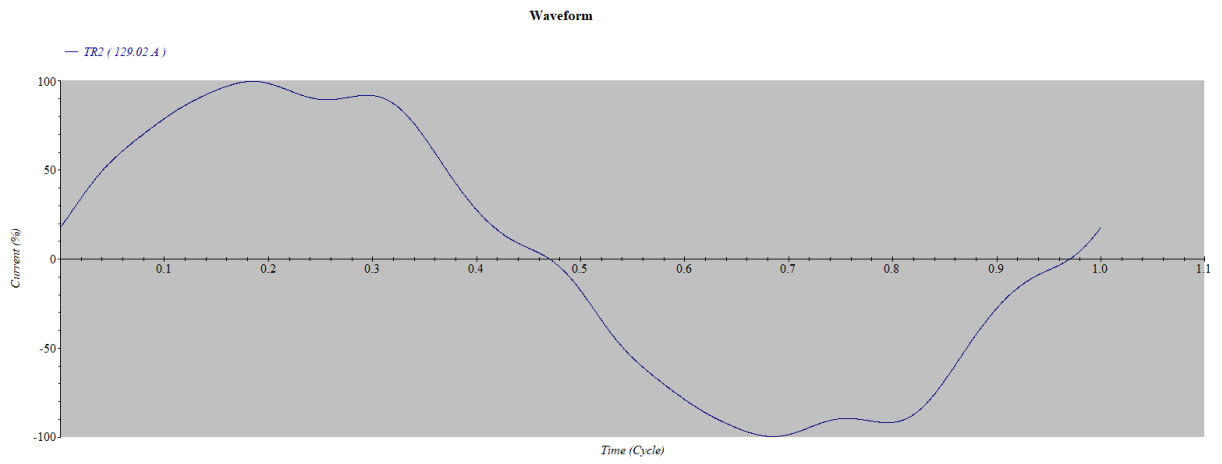
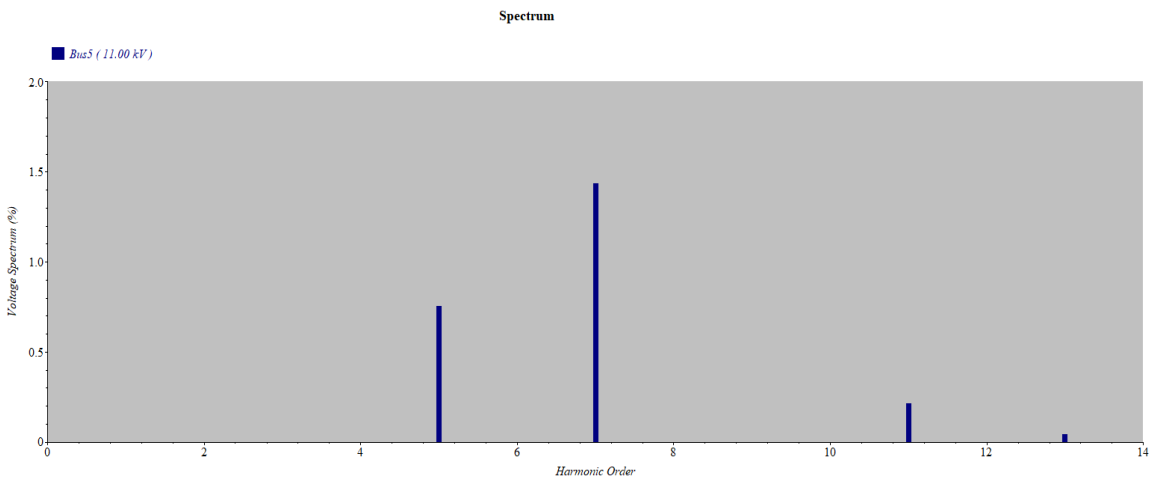


Figure4.12 wave form at fliter:



Figur4.13 Bus5 Spectrum at fliter

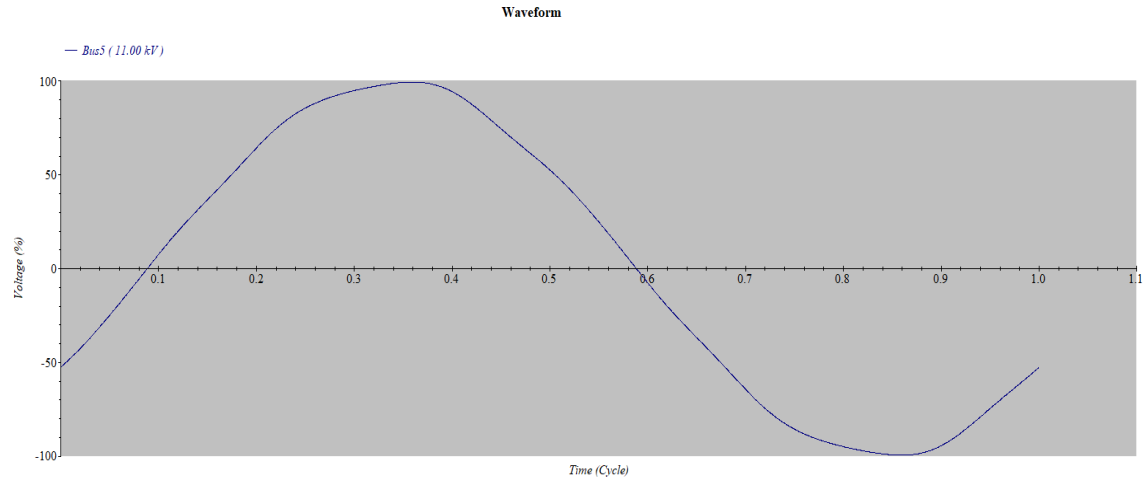


Figure4.14 Bus 5 wave form at filter

#### 4.1.1.1: Discussion of third scenario

It's clearly that the total harmonic distortion (THD) is successfully reaches the acceptable limits.(3%) ,and the wave form had been cleared near to pure sinusoidal after adding the filter.

# CHAPTER FIVE

## Conclusion and Recommendations

### 5.1 Conclusion:

As a whole, harmonic phenomena has been discussed in this research. Also the harmonic sources, effects, analysis methods and mitigation techniques were presented. Sample of Sudanese Electricity Distribution Company (SEDC) network has been taken as a case study By using ETAP software the substation has been analyzed and harmonic distortion was found after on site readings and simulation scenarios. Then the results was shown that the suggested solution for the problem are very good comparing with before solution. And also the result explain that the capacitor banks on the substation can magnify the effect of harmonic, from this research the following points can be concluded:

- Harmonic effects depend on the type of the load and level of distortion.
- The most effective and common technique for controlling harmonic distortion in industry is the passive filtering techniques. Because it economic and provide reactive compensation in addition to filtering action.
- The simulation program ETAP is very simple and effective software for analyzing the complex network.

### 5.2 Recommendations:

From the result it has been notice that insertion of capacitor banks can effect on amplification of harmonic current so the recommendation can be as follow:

- After investigation of load and level of harmonic distortion on substation providing passive filter at every substation will be necessary and considering

resonance conditions must be considered.

- Taking care of using several passive filters because each of them provides amount of reactive power.
- A research must be done, about how the harmonics can be manipulated to be useful rather than reduce it.



## REFERENCES

- [1] Francisco C. De La Rosa. “Harmonic and Power Systems”, Taylor & Francis Group, LLC, 2006.
- [2] IEEE. “IEEE Recommended Practice and Requirements for Harmonic Control in Electrical Systems”, 1992. Standard 519.
- [3] Jos Arrillaga, Bruce C Smith Neville R Watson, Alan R Wood. “Power System Harmonic Analysis, 2<sup>Nd</sup> Edition”, University of Canterbury, New Zealand, 2000.
- [4] Ewald F. Fuchs, Mohammad A.S. Masoum. “Power Quality in Power Systems and Electrical Machines, 1<sup>st</sup> Edition”, University of Colorado, USA, 2008.
- [5] “ETAP 12.6 user guide. Harmonic Analysis”, 2002.
- [6] Timothy James Browne. “Harmonic management in transmission networks”, Ph.D. thesis, University of Wollongong, Australia, 2008.
- [7] Azhar Ahmed. “Mitigation of Triplen Harmonic in 3-Phase 4-Wire Electrical Distribution System”, Ph.D., University of Teknikal Malaysia, Malaysia, 2007.
- [8] Thomas M. Blooming, Daneil J. Carnovale. “Application of IEEE Std 519-1992 Harmonic Limits Standard 519”. 2004
- [9] Schneider Electric Industries, “Harmonic mitigation Solution Handbook”, April 2009.
- [10] H. AKAGI. “Modern active filters and traditional passive filters”, Tokyo Institute of Technology, Japan, 2001
- [11] Hillary Tin, A. Abu-Siada and M. S. Masoum, “Impact of Harmonics on the Performance of Over-Current Relays”, Curtin University, Bentley, WA6102, Australia.
- [12] Herbert L. Ginn, Leszek S. Czarnecki, “An Optimization Based Method for Selection of Resonant Harmonic Filter Branch Parameters”, IEEE TRANSACTIONS ON POWER DELIVERY, VOL. 21, NO. 3, JULY 2006.

[13] A. S, 2279-2-1991, "Disturbances in mains supply network", part 2; "limitation of the harmonics caused by industrial equipment", standards Australia 1991.

[14] Turan Gonen, "Electrical Power distribution System" California state university, California, 2008

[15] Ramasamy Natarajan, "Computer-Aided power System Analysis", Practical Power Associates Raleigh, North Carolina, U.S.A, 2002.