



Sudan University of Science and Technology
College of Graduate Studies



Safety and Security Systems in Buildings

**(A Study of: Sudanese Standards Metrology Organization
& Greater Nile Petroleum Operating Company Buildings)**

أنظمة الأمن والسلامة في المباني

(دراسة مبنى الهيئة السودانية للمواصفات والمقاييس ومبنى شركة النيل الكبرى
للبتروول)

A thesis Submitted in Partial fulfillment of the Requirement for the Degree of
Master of Architecture (Buildings Services)

By: Basma Kamal
Alzubair

Supervised by: **DR. Esam**
Abbakar

Aug 2019

بِسْمِ اللَّهِ الرَّحْمَنِ الرَّحِيمِ
الْحَمْدُ لِلَّهِ رَبِّ الْعَالَمِينَ

بِسْمِ اللَّهِ الرَّحْمَنِ الرَّحِيمِ

يونس (25)

DEDICATION

To my beloved country

To my mother and father

To brothers and sisters

To friends

To both who supported me and tightened my hand

Dedicate my humble efforts

ACKNOWLEDGMENT

I would like to express my deepest appreciation to all those who provided me the possibility to complete this research, and my special thanks of gratitude to my teacher (Dr. Esam Abbakar) as well as our dean and the staff of SUST University.

Secondly i would also like to thank my parents and friends who helped me a lot in finalizing this research within the limited time frame.

المستخلص

وجدت أنظمة الأمن والسلامة (Safety and security systems) مزيداً من الاهتمام في الوقت الحاضر، فهي تعتبر أساسيات لبيئات البناء التي بدأت تظهر في اتجاه البنية الأساسية للمبنى. تقدم هذه الرسالة نظم الأمن والسلامة في المباني.

يركز هذا البحث على نظام التحكم في الدخول (access control system) ونظام كاميرات المراقبة (CCTV) (Closed Circuit Television) ونظام مكافحة الحرائق وإنذار الحريق (firefighting and fire alarm system)، تنفيذ كل نظام والمزايا التي يحققها. حيث توفر هذه الأنظمة حلاً أفضل لمعظم المشكلات التي يواجهها مستخدمو المبنى، حيث تتمثل المشاكل في السرقات والتعدي على الممتلكات بالإضافة لأخطار الحريق وغيرها من المخاطر.

تعتمد منهجية البحث المستخدمة في الإجابة على أسئلة البحث وتحقيق الأهداف البحثية على وصف ظاهرة للوصول إلى أسباب هذه الظاهرة والعوامل التي تتحكم فيها. تمت دراسة بعض الحالات واستخدمت طريقة المسح للإجابة عن الأسئلة التي يطرحها البحث. تم تجميع نماذج البيانات وأجري تحليل البيانات بواسطة (SPSS) (Package for Social Sciences Statistical)، وتم تحليل البيانات ومعالجتها. كانت النتائج تتعلق بشكل أساسي بأهمية هذه الأنظمة وكيفية تنفيذها لمنع الحوادث والأخطار والحرائق من الحدوث وإذا حدثت، فإن هذه الأنظمة تحمي المستخدمين والمبنى. أخيراً، تمت كتابة التوصيات وفقاً للنتائج للتأكيد على أهمية هذه الأنظمة وتطبيقها في المباني مستقبلاً.

ABSTRACT

Safety and security systems have received increased attention nowadays they are fundamental aspects of building environments that are emerging trend adopted across critical infrastructures. This thesis introduces a building safety and security system.

This research focuses on access control system, CCTV system and firefighting system. The implementation of each system and the advantages they achieve. These systems provide a best solution to most of the problems faced by building occupants, which includes thefts, property encroachment, fire hazards and other hazards.

Research methodology used in answering research questions and achieving research objectives is based on describing a phenomenon to reach the causes of this phenomenon and the factors that control it. Survey Method, was used to answer questions. Data forms were compiled and data analysis was performed by the (Statistical Package for Social Sciences) (SPSS), the data were analyzed and then processed. Results were mainly about the importance of these systems and how the implementation of them prevent accidents, dangers and fires from happening and if they occur these systems protect occupants and keep the least damage possible for the building. Finally recommendations were written according to results and to insure the importance of these systems and to be applied to buildings further.

List of contents

Dedication	II
Acknowledgment	II
المستخلص	IV
Abstract	V
List of contents	VI
List of tables	VIII
List of figures.....	IX
CHAPTER ONE: INTRODUCTION	1
1-1Preface:.....	1
1-2 Research problems:.....	1
1-3 The study questions:	2
1-4 Goals of the research:.....	2
1-5 Significance of the research:	2
1-6 Research methodology:.....	2
1-7 Sources of information.....	2
1-8 Structure of the study:.....	3
1-9 The limits of study:	3
1-10 Terminology of study:.....	3
CHAPTER TWO: LITERATURE REVIEW	5
2-1 Building access control systems:.....	5
2-2 CCTV systems:.....	18
2-3 emergency and fire systems	45
2-4 PREVIOUS STUDIES.....	63
CHAPTER THREE: RESEARCH METHODOLOGY	65
3-1 general introduction	65
3-3 Steps of the study:.....	65
3-4 Methodology tools:	66
3-5 Description of the questionnaire.....	66

3-6 Statistical Processing Methods.....	66
3-7 Test Reliability and Stability Tool Study	67
3-8 Analysis and discussion:	69
CHAPTER FOUR: CONCLUSION AND RECOMMENDATIONS	88
4-1 Introduction	88
4-2 Results	88
4-3 Recommendations.....	92
4-4 Suggested topics	92
BIBLIOGRAPHY:.....	93
CHAPTER FIVE: APPENDICES.....	95

LIST OF TABLES

Table (3- 1): Total Cronbach's Alpha.....	67
Table (3- 2): Total Correlation and Cronbach's Alpha.....	67
Table (3- 3): Function of the building	69
Table (3- 4): Age of the building.....	70
Table (3- 5): Number of building users	70
Table (3- 6): Number of floors.....	71
Table (3- 7): Material of building structure	72
Table (3- 8): Material of building finishing.....	72
Table (3- 9): Have you been in trouble to access the building?	73
Table (3- 10): Have you been roped in the building before?.....	74
Table (3- 11): Do you have a backup power supply?	74
Table (3- 12): Do you have an emergency plan?	75
Table (3- 13): Do you have access control system?.....	76
Table (3- 14): What type of Access system?	76
Table (3- 15): How many doors are controlled? (Internal)	77
Table (3- 16): How many doors are controlled? (External)	78
Table (3- 17): Does the system integrate with CCTV?	78
Table (3- 18): Do you have CCTV system in the building?.....	79
Table (3- 19): If yes, where are the cameras applied?	80
Table (3- 20): Camera mounting	80
Table (3- 21): Total number of cameras in the system (Internal).....	81
Table (3- 22): Total number of cameras in the system (External).....	82
Table (3- 23): Have the building been on fire before?	82
Table (3- 24): If yes, what is the cause of the fire?.....	83
Table (3- 25): Is there a designated smoking area provided?.....	84
Table (3- 26): Are there any means of fire detectors?.....	84
Table (3- 27): are there any means of emergency alarms?.....	85
Table (3- 28): Are there fire extinguishers?.....	86
Table (3- 29): Is there an automatic fire fighting system?	86
Table (4- 1): Results summary - General dangers.....	88
Table (4- 2): Results summary - Access Control System.....	89
Table (4- 3): Results summary - CCTV System.....	90
Table (4- 4): Results summary - Firefighting System.....	91

LIST OF FIGURES

Figure (2- 1): Components of a Basic System	6
Figure (2- 2): Door Strikes	7
Figure (2- 3): Magnetic Locks	7
Figure (2- 4): Door Bolt Locks	8
Figure (2- 5): Surface Mount Contacts	9
Figure (2- 6): REX Placement.....	10
Figure (2- 7): PIR.....	11
Figure (2- 8): How Orox Cards/ Readers Work.....	11
Figure (2- 9): Smart Cards	12
Figure (2- 10): Biometric Readers.....	13
Figure (2- 11): Controller Panel	15
Figure (2- 12): Fire-Rated Doors	15
Figure (2- 13): CCTV Component Diagram Example	20
Figure (2- 14): Color Reference Chart	24
Figure (2- 15): Image from Thermal Camera	25
Figure (2- 16): Representative CCTV Lens.....	27
Figure (2- 17): Calculating FOV	29
Figure (2- 18): Distortion Comparison	29
Figure (2- 19): Sealed Camera Housing	31
Figure (2- 20): Impact-Resistant Housing	31
Figure (2- 21): Tamper-Resistant Housing	32
Figure (2- 22): Bullet-Resistant Housing	32
Figure (2- 23): Camera on Pan-Tilt Head with a Pole Mount	34
Figure (2- 24): Microprocessor-Based Switcher.....	36
Figure (2- 25): Monitoring Station with Matrix Switcher.....	37
Figure (2- 26): Coaxial Cable Construction	39
Figure (2- 27): Telephone Network Example	41
Figure (2- 28): Integrated Security System.....	43
Figure (2- 29): Fire Triangle	46
Figure (2- 30): Classification of Fires	50
Figure (2- 31): Coiling fire hose.....	53

Figure (3- 1): Function of the building	69
Figure (3- 2): Age of the building	70
Figure (3- 3): Number of building users.....	71
Figure (3- 4): Number of floors.....	71
Figure (3- 5): Material of building structure.....	72
Figure (3- 6): Material of building finishing	73
Figure (3- 7): Have you been in trouble to access the building?	73
Figure (3- 8): Have you been roped in the building before?	74
Figure (3- 9): Do you have a backup power supply?	75
Figure (3- 10): Do you have an emergency plan?.....	75
Figure (3- 11): Do you have access control system?	76
Figure (3- 12): What type of Access system?.....	77
Figure (3- 13): How many doors are controlled? (Internal)	77
Figure (3- 14): How many doors are controlled? (External)	78
Figure (3- 15): Does the system integrate with CCTV?.....	79
Figure (3- 16): Do you have CCTV camera system in the building?	79
Figure (3- 17): If yes, where are the cameras applied?	80
Figure (3- 18): Camera mounting.....	81
Figure (3- 19): Total number of cameras in the system (Internal).....	81
Figure (3- 20): Total number of cameras in the system (External)	82
Figure (3- 21): Have the building been on fire before?.....	83
Figure (3- 22): If yes, what is the cause of the fire?.....	83
Figure (3- 23): Is there a designated smoking area provided?	84
Figure (3- 24): Are there any means of fire detectors?	85
Figure (3- 25): are there any means of emergency alarms?	85
Figure (3- 26): Are there fire extinguishers?	86
Figure (3- 27): Is there an automatic fire fighting system?	87

CHAPTER ONE: INTRODUCTION

1-1 Preface:

Insecurity and crime constitute some of the major problems facing our immediate society today.

People live with fear of being attacked by burglars, vandals and thieves. Despite all the effort, resources and time that has been devoted to the development of tools that will reduce crime rates and make the world a safer place to live, these problems are still on the increase. These gave rise to the need for an increasing development in the technology of alarm systems which utilizes various principles such as infrared motion detection, light (photo) sensitive electronic devices and so on. Even with the introduction of these alarm systems which have reduced greatly the level of insecurity, there is still a problem of false alarm which needs to be minimized. In order to effectively reduce the level of insecurity and avoid false alarms which can create unnecessary unrest, a touch activated security system is required. This system if properly designed will provide security and ensure alarms are activated only when an unauthorized person try to gain access to the protected area or device by touching the entrance or any other part of the device.

Building assets should have adequate security systems and processes in place to protect people, property, operational capability and information.

Security management is the process of identifying, implementing and monitoring systems and processes for the protection of people and building assets against loss, misuse, damage, fire or any other danger that threatens its safety.

1-2 Research problems:

1. Dangers and ropers in buildings which threats users' lives.
2. Some response to alarms and dangers that threat the buildings are slow (roping, fire, etc.).
3. That users don't have enough awareness about what to do in case of danger.
4. The implementation of safety and security systems.

1-3 The study questions:

1. What are the main dangers that threaten the occupants and the reasons that they occur?
2. Are the safety and security systems applied in buildings according to the standards?
3. Are the safety and security systems working efficiently?

1-4 Goals of the research:

1. Identify what advances in safety and security systems are having the greatest effect on buildings, and how these advances could be applied to buildings.
2. Compare the types of technological approaches used in security systems, access control, people movement control, CCTV, emergency systems, firefighting, and the types of problems they can address in buildings.
3. Identify examples of the application of safety and security systems and what are already deployed or are in development and the benefits they provide.

1-5 Significance of the research:

1. Develop a security management plan.
2. Monitor and review plans to ensure its effectiveness.
3. Enhance modern technology by ensuring safety and security in buildings.

1-6 Research methodology:

Methodology adopted in this research on the case and analytical study and collect information through:

1. Follow based sources and scientific references the scientific method to determine the means and procedures stipulated by the laws in the safety and security in buildings.
2. Follow the statistical and analytical method to check the availability of safety and security systems.
3. Use of engineering schemes available to the researcher to demonstrate these methods and procedures.

1-7 Sources of information

1. Field visits.
2. Interviews and meetings with.

3. Conferences training course and research paper.
4. Research and published studies, journals, newspapers.
5. Reference books.
6. Reports and statistics.

1-8 Structure of the study:

The study consists of five chapters:

Chapter One: It consists of introduction, and begun to identify the problem, objectives and methodology,

Chapter Two entitled: Conceptual framework. Including definition of safety and security systems in buildings, building access control systems, CCTV systems, emergency and fire systems, and the implementation of these systems in buildings and its benefits.

Chapter Three entitled: Research methodology: including introduction, steps of study, data analysis.

Chapter Four: Consists of results and conclusions and recommendations.

Chapter Five: Appendices.

1-9 Scope of study:

Khartoum city.

2018-2019.

1-10 Terminology of study:

Safety:

Safety is the state of being "safe" (from French sauf), the condition of being protected from harm or other non-desirable outcomes. Safety can also refer to the control of recognized hazards in order to achieve an acceptable level of risk.

(Source: www.master.postgraduatestudy.eu)

Security:

Security is freedom from, or resilience against, potential harm (or other unwanted coercive change) from external forces. Beneficiaries (technically referents) of security may be persons and social groups, objects and

institutions, ecosystems, and any other entity or phenomenon vulnerable to unwanted change by its environment.

Security mostly refers to protection from hostile forces, but it has a wide range of other senses: for example, as the absence of harm (e.g. freedom from want); as the presence of an essential good (e.g. food security); as resilience against potential damage or harm (e.g. secure foundations); as secrecy (e.g. a secure telephone line); as containment (e.g. a secure room or cell); and as a state of mind (e.g. emotional security).

The term is also used to refer to acts and systems whose purpose may be to provide security: (e.g. security forces; cyber security systems; security cameras). (Source: www.master.postgraduatestudy.eu)

Building:

"Building," in addition to its ordinary meaning, specifically includes any dwelling, hotel, commercial structure, automobile, truck, watercraft, aircraft, trailer, sleeping car, railroad car, or other structure or vehicle, or any structure with a valid certificate of occupancy. (Source: [2015 Kentucky Revised Statutes](#))

CHAPTER TWO: LITERATURE REVIEW

Introduction:

This chapter deals with the three main topics that representing safety and security systems. This chapter reviews Access control system, CCTV system and firefighting system. And explain each system and its components and benefits and how it works.

2-1 Building access control systems:

2-1-1 Introduction

Access control is a means to authorize, restrict or deny entrance or exit of people and/or vehicles into a specific area.

It is used to protect property, employees and other assets such as inventory, equipment, information and cash.

Although access control can refer to any method for achieving this, such as locks and keys or security guards, it specifically describes a more effective, high-tech means of protection. (Source: [Application notes – access control, Yorkland controls, 2007](#)).

2-1-2 benefits of access control systems

1. Asset Protection
2. Prevention of Illegal Entries
3. Enhancement of Personal Safety
4. Reduction of Security Costs
5. Facilities Management

2-1-3 TYPES OF access control systems

Keys

1. Costly to re-key
2. Easy to duplicate

Human Guards

1. Expensive
2. Possibility of human error

Electronic Access Control

1. Inexpensive to maintain
2. Difficult to duplicate

3. Validate and invalidate a user in seconds
4. Identify Who, Where and When (audit trail)
5. Readily adaptable to changing security needs
6. Temporary users

2-1-4 Basic System

Components

1. Controller
2. Contact
3. Door strikes
4. Card reader
5. Request to exit

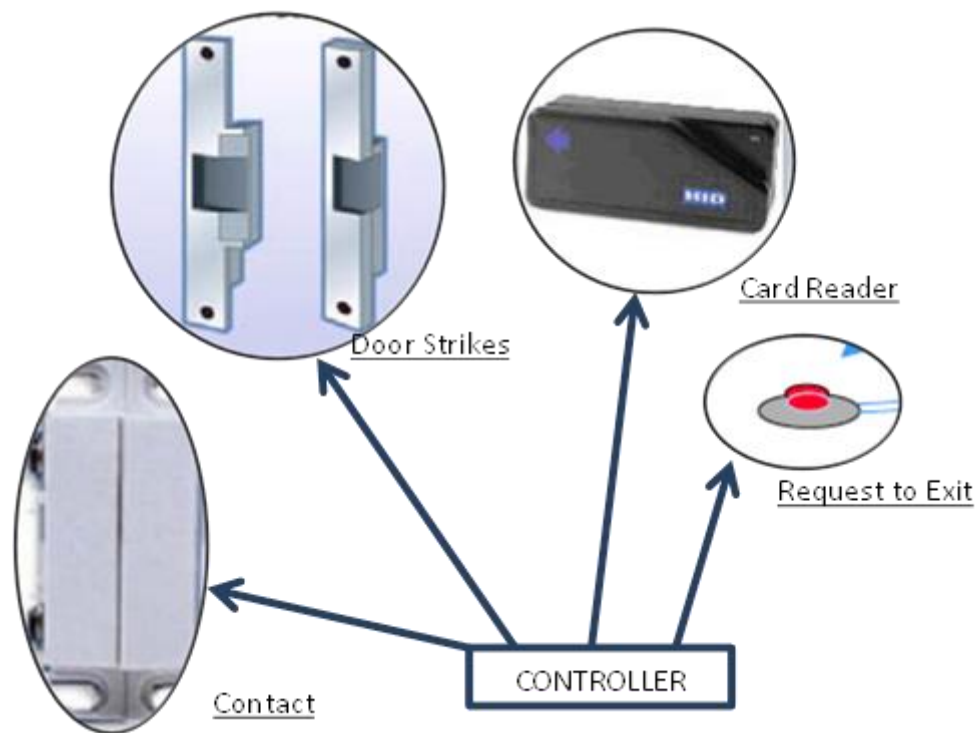

Figure (2- 1): Components of a Basic System

Source: a simple and reliable touch sensitive security system, Adamu Murtala Zungeru1, 2014.

How it Works

1. User swipes card
2. Reader sends card data to controller
3. Controller

- interprets card data
 - checks time and date info
 - makes decision access granted or denied
4. Locking device receives signal from controller to unlock OR remained locked
 5. Activity is logged or recorded on output device

DOOR CONTROL HARDWARE (DOOR STRIKES)

Electric Strikes

Installed on the mechanical lock side of the door, electric strikes are the most common door control apparatus.

Powered by low voltage AC or DC, strikes can be selected to be fail safe, meaning that the door is open if power fails, or fail secure, where the door remains locked in the absence of electrical power.

Door strikes allow the use of panic hardware, so that a person inside the room or building can push the release bar to exit the building even if the strike is in the closed position.

Electric strikes are typically used on framed wooden and metal doors, and are generally the least expensive way to control doors.



Figure (2- 2): Door Strikes

Source: a simple and reliable touch sensitive security system, Adamu Murtala Zungeru1, 2014.

Magnetic Locks

Some door types, such as glass doors or double doors that do not have a center post cannot be controlled with a strike.

Magnetic locks use an electromagnet to provide a powerful locking force to a door.

The electromagnet is installed in a fixed position, while a metal plate is installed on the moving portion of the

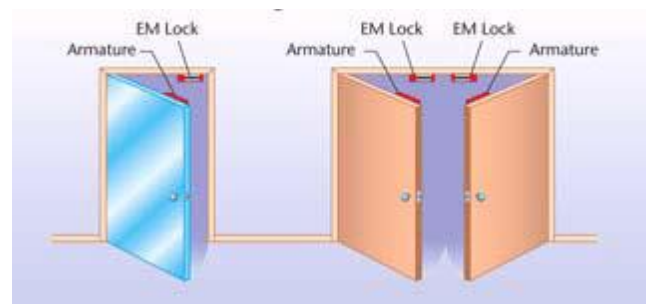

Figure (2- 3): Magnetic Locks

door, lined up with the magnet.

Magnetic locks can provide various amounts of holding pressure, from 300 to 1,200 pounds. These devices are by nature fail safe, as removal of power, whether by the access system's controlling relay or by power failure, will release the door. Power supplies with backup batteries are often used to provide emergency power to magnetic locks.

Door Bolt Locks

Some doors cannot have a strike installed, and the usage of a magnetic lock may be impractical or aesthetically inappropriate. (An ornate arched door in a church).



Figure (2- 4): Door Bolt Locks

Door hardware vendors supply various types of electrical bolt locks, which throw a smooth bolt typically into the top or sometimes the bottom of a door, providing an electrically controlled locking mechanism. (Source: [Application notes – access control, Yorkland controls, 2007](#)).

DOOR POSITION (Status) DEVICES

Door position devices provide status of a door (door is open or closed) to the access control system, allowing it to engage locks, annunciate alarm conditions, and other actions that provide security.

For example, an authorized user may access a door and prop it open, allowing the unauthorized entry of other people and/or the removal of property. A door position device will detect the opening of the door upon the presentation of a valid credential (card), which starts a timer within the access system for perhaps 20 or 30 seconds.

When the door position device indicates that the door has shut, the access system can be set to relock the door control mechanism. If the door is propped open past the timer duration, local and remote alarm signals can be set off and transmitted.

The door contact is the most common type of door position indication. These contacts can be magnetic or mechanical, surface mounted or concealed, and are typically wired into the access control panel.

Any type of door contact can be used for this function, but it is important that this device's contacts be used only for the door position function, and not also connected to the intrusion detection system.



Figure (2- 5): Surface Mount Contacts

Source: Application notes – access control, Yorkland controls, 2007.

If only install one contact set on a door is allowed, DPDT (double pole double throw) contacts are available that provide two electrically separate contacts, one for the access system and one for the intrusion system.

In cases where it is difficult to install a door contact, door status can be achieved by installing specific door strikes or *wired hinges* that include a door status output.

Status is built in to the locking device. Using these devices can reduce the cost of a system, because they can make the installation of a separate contact unnecessary.

Built-in devices are useful when installing an access system on a fire-rated door.

Drilling holes in the fire door for the mounting of a contact set magnet may violate the door's fire rating integrity.

Whether a separate contact or an output from the locking device, door status devices are typically installed on each access-controlled door.

REQUEST TO EXIT DEVICES (REX)

REX devices are installed with the detection device near the controlled door or doors to allow non-alarm exits of individuals.

In the case of an access-controlled door, a card reader is mounted on the outside which allows authorized personnel in. The door is equipped with a position contact (door status) that tells the access control panel whether the door is open or closed. When a person chooses to leave a building through this door, an input

must be provided to the access panel, telling it to unlock the door. This REX input can be another card reader on the inside of the door, and the person can present a valid credential to activate the access system. Placing another reader on the inside of the door is costly, and is generally only used in high-security applications where anti-pass back functions are needed.

Instead, some type of input device is installed near the door, providing either manual or automatic release of the door when people approach it. This release input also allows the door to be opened from the inside without generating an alarm condition.

In some cases, the request to exit device is a labeled switch that is manually pressed. The request to exit input also can be included in the door's panic release push-bar.

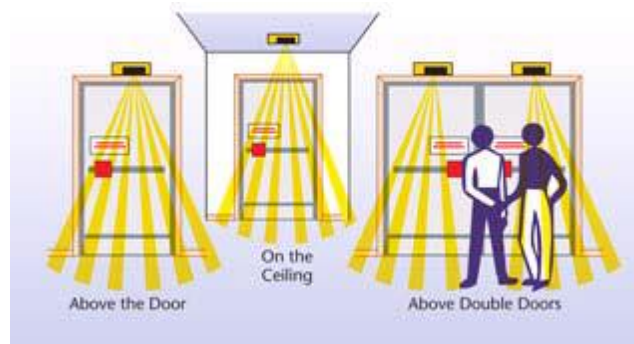

Figure (2- 6): REX Placement

(Source: Application notes – access control, Yorkland controls, 2007).

Lower cost REX sensors use motion detection technology, such as passive infrared (PIR) detection, which senses that a person is standing in proximity to the door. When activated, the electronic REX will release the door for a specified time period, perhaps 30 seconds, and automatically relocks the door when the connected door position sensor indicates a closed position. This method provides a *hands-free* door release capability, with no manipulation or credential required to exit the door.

In some applications, the capability of using secondary sensor inputs can provide added security to the door exiting procedure, while reducing nuisance alarms. An additional sensor, such as a PIR or pressure mat, can be located so that people walking towards the door trip the first sensor, which starts a timer in the REX. If the motion detection in the REX detects movement within 10

seconds, the REX will open the door. If the auxiliary sensor isn't tripped first, the REX will not open the door.

Electronic REXs can provide a variety of door control options, reducing cable runs and labor costs, while providing an easy-to-use system for end users.



Figure (2- 7): PIR

Source: a simple and reliable touch sensitive security system, Adamu Murtala Zungeru1, 2014.

CREDENTIAL TECHNOLOGY

Different types of devices can be installed to provide an input for authorized users to open a door or access a specific device. Credential readers take the input from:

- User's Access Card
- Keypad Input
- Biometric Information

Information is transmitted to the access control panel, which decides to allow or disallow the access request based on its programming and database.

Most credential readers, regardless of type, will standard communications protocol such as Wiegand.

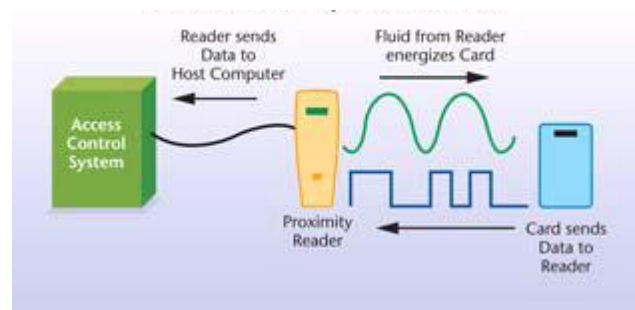

Figure (2- 8): How Orox Cards/ Readers Work

(Source: Application notes – access control, Yorkland controls, 2007).

ADVANTAGES

The card can stay within a purse or wallet, not requiring the user to extract them.

Card read times are very fast because access control information is in a simple, short format. There is no card slot, which can be jammed with glue or ice.

Cards can be printed with the user's photo and other information, providing a combination ID badge and access control card.

SMART CARDS



Figure (2- 9): Smart Cards

Source: Application notes – access control, Yorkland controls, 2007.

Smart cards contain a microchip with read and write capabilities which, in essence, makes the card a mini-computer with the ability to encrypt and authenticate the data – providing sophisticated levels of security for communication. These cards can be used to hold biometric access data, debit card functions, and more.

Smart cards can be read using either a contact or contact-less methodology. Contact-type systems, where the card physically is inserted in the reader, are a mature technology than contact-less and provide higher security, as the data from the card is not transmitted through the air.

Contact-less provides faster read/write capability and greater memory storage. Contact-less smart cards use RF to transmit data to a reader and provides faster user interface and building access.

An advantage to smart card systems is the ability of a single card to store and transmit separate information for different systems. For example, a single card can be used to access a building via the access control reader, and also provide a separate set of user authentication information to allow access to other resources, such as computers or programs within a computer system. A typical usage of smart cards is to combine access control and debit card functions within single-user cards at universities, hospitals, and other such facilities.

KEYPADS



Figure (2- 10): Biometric Readers

(Source: Application notes – access control, Yorkland controls, 2007).

Keypads provide access credential, without the user having to carry or produce a physical card. Although no physical card exists that could be potentially passed to an unauthorized user- the keypad code itself may be told to another person.

Keypads are slower than card readers, as users must remember their code, punch it into the keypad, and wait for the door release. This issue should be carefully considered if high volume user entry is required, for example if all employees must enter through one or more specific doors at nearly the same time.

BIOMETRIC READERS

Fingerprints, palm prints, and the human iris possess individually unique characteristics that can be used to verify a person's identity. This *biometric* information can be stored within an access control system and read by specific devices. The primary advantages of biometrics are very high security and the elimination of specific credential devices (cards) and their related costs.

COMBINED TECHNOLOGY USE

The technologies described can be used in various combinations. For example, a user can drive an automobile into a garage, and use a prox card to gain entry for

parking. The same user/card combination may be presented at the entry door proximity reader to allow door entry, while the card may be used in combination with a biometric reader to allow entry to a sensitive room.

Smart card technology allows cards to contain the biometric characteristic file of the user.

The user first enters a keypad code, presents his or her biometric input (fingerprint, iris), and has the card read. The access system then can verify that the user keypad code presented matches the biometric information contained on the user's card. This can speed up the process of verification, while eliminating the centralized storage of sensitive biometric information.

CONTROLLER PANELS

Once the selection of door release, type of credential reader, door release system and REX issues have been made, the type of controllers and system architecture is considered. Access controller panel hardware and system software differ across manufacturer platforms.

The controller panel will typically have electrical connections for the selected credential reader, a relay output to control the door release, door position input, programmable inputs and outputs, and inputs for the REX.

Access controller panels will house an on board software and microprocessor to review incoming information and activate the system's capabilities. An on-board database contains the credential verifying information for the users of that particular controlled door or device. When a credential is presented, the access controller will compare the input to its database to determine whether access should be allowed to a particular door at a particular time and day.

For larger systems, controllers are usually downloaded with a credential database from a central host computer. The decentralized system allows the controller panels to make programmed access decisions regardless of whether there is communication with the host computer.

In most cases, specific host or administration software must be used with specific access controller panels. This means that the same vendor's software and access controller panels must be used within a single system. Credentials may possibly be used in a cross-platform situation, with the same card being programmed into two (or more) separate systems.

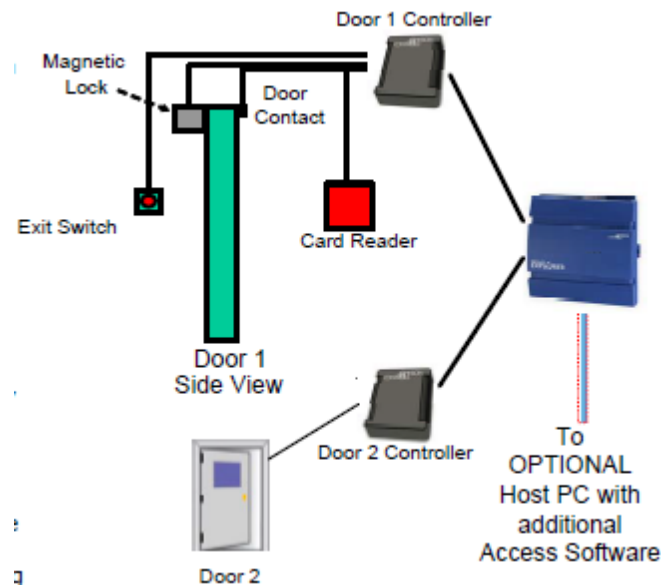

Figure (2- 11): Controller Panel

Source: Application notes – access control, Yorkland controls, 2007.

FIRE-RATED DOORS

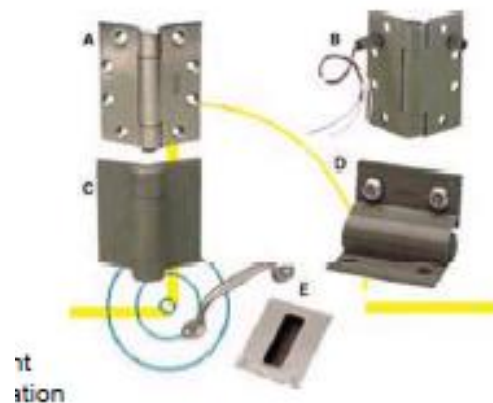

Figure (2- 12): Fire-Rated doors

Source: Application notes – access control, Yorkland controls, 2007.

Doors that are fire rated are designed and built to provide a barrier against the spread of a fire from one room/area to the next. Any modification to a fire-rated door, such as drilling, channeling, or installing a magnet for a door position switch, will violate that door's fire rating as far as the governing authorities are concerned.

Specialized hardware, such as door hinges with *built-in position switches*, can be used successfully on fire-rated doors. It is important to know what doors are

fire rated in an , and to approach the application of access devices for those doors so that the door remains intact and is not modified in any way.

Anti-Pass Back

Anti-passback is a feature to prevent an authorized user from presenting a credential card to access an area, and then he or she “passes back” that card, say through a window or another door, to an unauthorized user, who then uses the same card to access the building.

Anti-passback is accomplished by the installation of two credential readers, one on entry and one on exit, at particular doors. Users must present their card to enter, and also to exit the door. The access control system will register when someone has entered, and when he or she has left. If someone enters and passes back his or her credential to another person, the unauthorized user will not gain entry, because the system will know that the proper user’s credential already has been used to enter the building and that he or she hasn’t yet exited.

Therefore, the use of the credential by the second user is invalid.

Timed Anti-Pass Back feature allows you to enter a specific time so when the card is used, it will not work again for a specified amount of time.

Anti-passback violations can create local or remote alarm conditions, as well as be logged in the access control event data recording. (Source: [Application notes – access control, Yorkland controls, 2007](#)).

DEVICE POWER

The planning of an access control application must include the selection of power supplies to provide adequate power to operate the connected door devices. A number of security equipment vendors provide power supplies specifically designed for use with access control devices.

A system that is fail safe will open door release devices in the event of power failure, while a fail secure system retains the door release in the closed position. Installers should consult local authority requirements for the release of labeled exit doors in the event of primary power failure or fire alarm system activation.

Security system dealers need to calculate the amount of current necessary to operate the door release devices, and how much standby battery power should be provided to maintain the operation of the access system in a power failure.

Separate Power for Strikes & Mag Locks

Door releases are to be powered separately from other electronics in the system.

Door release devices such as strikes and magnetic locks typically operate at 12 or 24 volts AC or DC. Although the amount of current drawn by a strike (typically 150 mA @ 24 VDC) or magnetic lock (125 - 350 mA @ 24 VDC) is not excessive, electrical spikes and surges occur when the device is energized and de-energized. These issues can create interference, which can hamper the performance of other electronic devices connected to the same power supply.

2-2 CCTV systems:

2-2-1 INTRODUCTION

CCTV systems provide surveillance capabilities used in the protection of people, assets, and systems. A CCTV system serves mainly as a security force multiplier, providing surveillance for a larger area, more of the time, than would be feasible with security personnel alone. CCTV systems are often used to support comprehensive security systems by incorporating video coverage and security alarms for barriers, intrusion detection, and access control. For example, a CCTV system can provide the means to assess an alarm generated by an intrusion detection system and record the event.

A CCTV system links a camera to a video monitor using a direct transmission system. This differs from broadcast television where the signal is transmitted over the air and viewed with a television. New approaches within the CCTV industry are moving towards more open architecture and transmission methods versus the closed circuit, hard-wired connection systems of the past.

CCTV systems have many components with a variety of functions, features, and specifications. Key components include cameras, lenses, data distribution, power, and lighting, among others. CCTV technologies continuously undergo feature refinements to improve performance in areas such as digital equipment options, data storage, component miniaturization, wireless communications, and automated image analysis.

The components, configuration options, and features available in today's CCTV market create a complex set of purchasing options. It is the intent of this handbook to provide information on the capabilities and limitations of CCTV components that will aid an agency procuring a new CCTV system or upgrading an existing one. (Source: [CCTV student's handbook, Kristina Irelan and John Ehlers, 2005](#)).

2-2-2 How a camera works:

At its most basic level, a camera has a series of lenses that focus light to create an image of a scene. But instead of focusing light onto a piece of film, video is focused onto a Charge Coupled Device that records light electronically. The semiconductor device (CCD) measures light with a half-inch panel of 300,000 to 500,000 tiny light-sensitive diodes called photosites. Each photo site measures the amount of light (photons) that hits a particular point, and translates this information into electrical charges. A brighter image is represented by a higher electrical charge, and a darker image is represented by a lower electrical charge. But measuring light intensity only gives us a black-and-white image. To create a color image the CCD has to detect not only the total light levels, but also the levels of each color of light. Since you can produce the full spectrum of colors by combining the three colors red, yellow and blue, the CCD only needs

to measure the levels of these three colors to be able to reproduce a full-color picture.

2-2-3 CCTV SYSTEM DESIGN

Following a sound design process enables organizations to make purchasing decisions that result in the procurement and installation of a CCTV system that meets functional and operational requirements. As CCTV is part of a multi-layered security approach, a system design should begin with a comprehensive needs assessment to ensure security risks and mitigation plans are identified. Clear requirements, a comprehensive site survey, and proper equipment selection and installation must all be considered when designing a CCTV system. (Source: CCTV student's handbook, Kristina Irelan and John Ehlers, 2005).

2-2-4 COMPONENTS OF CCTV SYSTEMS

CCTV uses components that are directly connected to generate, transmit, display, and store video data. A CCTV system can be as simple as a camera purchased from a retail electronics store connected to a video monitor. However, larger systems operated by professional security personnel are comprised of a number of components falling into several basic categories:

- ✓ Cameras;
- ✓ Lenses;
- ✓ Housings and mounts;
- ✓ Monitors;
- ✓ Switchers and multiplexers; and
- ✓ Video recorders.

Many features exist within each of these categories that can satisfy an agency's operational requirements in the most challenging environments. The most complex CCTV systems may incorporate hundreds of cameras and sensors integrated into one overall security network. Figure 3-1 provides a CCTV component diagram example.

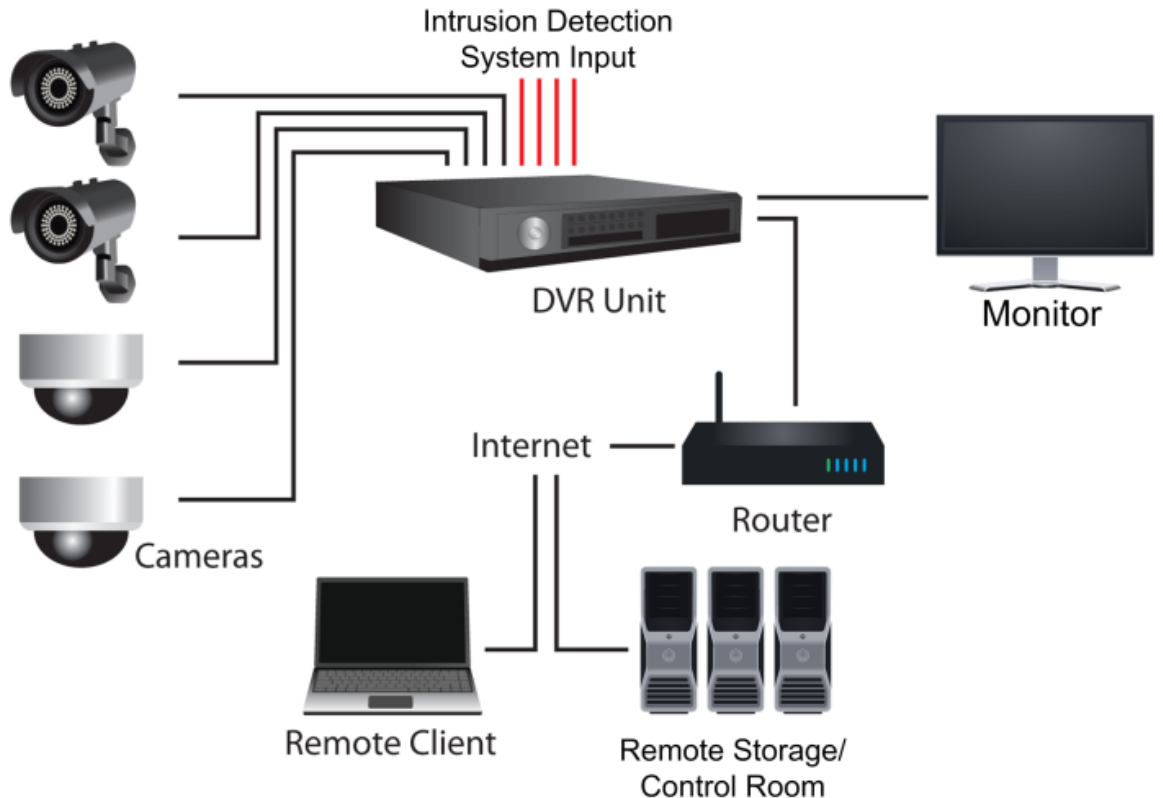

Figure (2- 13): CCTV Component Diagram Example

(Source: CCTV student's handbook, Kristina Irelan and John Ehlers, 2005).

Most new CCTV systems maximize the advantages of digital technologies by utilizing electronic databases, compact components, and wireless transmission techniques. With larger quantities of data being collected, it is essential that the system be capable of retaining data in accordance with the organization's policies and procedures.

Cameras

Cameras are an essential component of any CCTV system. Matching the right CCTV camera to a particular application is increasingly complex due to rapid technological developments and a greater range of applications. A system's performance is affected by many factors beyond those listed in the vendor data sheets. Effective camera selection requires detailed knowledge of the camera, application, supporting architecture, and host environment.

All CCTV system include three basic elements:

Image sensor–Converts light (photons) into electronic signals;

Lens—Gathers light reflected from a subject and focuses the light on the image sensor; and

Image processing circuitry—Organizes, optimizes, and transmits video signals.

The type of camera best suited for a CCTV system depends on the operational environment and how it will integrate into the system. The answers to the following questions may help determine the best camera type:

- ✓ What is the desired image quality?
- ✓ What size is the desired field of view (FOV)?
- ✓ How much lighting is available?
- ✓ Will the camera be installed indoors or outdoors?
- ✓ Will the video be monitored on a full time basis?
- ✓ How will the video be transmitted?
- ✓ Will the camera be exposed to extreme conditions?

There are many types of cameras designed to perform under specific environmental conditions but cameras can be grouped into two primary categories: fixed and pan-tilt-zoom (PTZ). Fixed cameras are intended to constantly view a single scene, while PTZ cameras are motor driven and can pan left or right, tilt up or down, and zoom in or out to instantly customize the view as needed. A combination of fixed and PTZ cameras are often used to provide the required surveillance coverage. (Source: [CCTV student's handbook, Kristina Irelan and John Ehlers, 2005](#)).

Fixed Cameras

Fixed cameras are mounted in a stationary position and are focused on a single FOV, typically one particular area of interest. These cameras can be used indoors or outdoors and can be installed overtly or covertly. Fixed cameras vary in size and can be mounted in a wide range of locations (e.g., inside cabinets or control panels, or on poles, fence lines, or roofs).

Fixed cameras can be integrated with an electronic security system (ESS) and used to assess ESS alarms. For example, a fixed camera can surveil a secured gate but only record data when the gate opens, triggering an alarm. Fixed cameras are usually less expensive than PTZ cameras and require less maintenance as they have fewer moving parts.

PTZ Cameras

PTZ cameras come in a variety of sizes and shapes for interior and exterior uses. Typically, a PTZ camera can be turned and tilted on two axes to provide pan and tilt capabilities and the focal length of the lens can be varied to change the FOV. This enables PTZ cameras to offer more flexibility for viewing and capturing images in real time than fixed cameras. PTZ cameras can be operated manually or in an automatic scan mode, thus capturing the most relevant video possible.

In manual mode, the operator can control the direction of the camera depending on situational needs and zoom in on an object (e.g., a suspicious bag, a person's facial features, or a license plate) to capture specific details of interest.

PTZ cameras can also be configured to automatically scan back and forth over a wide area that cannot be covered by a single fixed camera. Preset positions can be programmed to switch views based upon specified time segments. For example, a PTZ camera could be programmed to change its view every 10 seconds to capture different areas of interest within the camera's overall surveillance area. (Source: [CCTV Technology Handbook, Space and Naval Warfare Systems Center Atlantic, 2013](#))

Connectivity Type

CCTV system may employ one of two types of data transmission:

Network Cameras—Network cameras connect to IP-based networks, including the Internet, and provide remote viewing and recording. Network cameras are also available in high definition (HD) which can provide greater image detail.

Analog Cameras—Despite increasing use of digital network cameras, a market for analog cameras still exists. This may be due to the cost involved in upgrading and converting to a new transmission process. Analog cameras have options for high resolution, making them applicable for various surveillance needs. These cameras also have some cyber security advantages because the coaxial cable they are connected with would require physical access to breach.

Day/Night Cameras

Day/night cameras offer flexibility by automatically adjusting to current lighting conditions. These cameras capture color images in daylight and switch to black-and-white to improve image quality at night. The camera relies on an

analysis of the current image or a photoelectric sensor to determine when to automatically remove the infrared-cut filter and switch to monochrome settings.

Low-Light or Night Vision Cameras

Cameras used to capture images in dark environments are either low-light or night vision cameras.

Low-light cameras are designed to perform in some level of ambient lighting, such as indoor restaurant lighting, street lamps, or a full moon; they are not intended for use in complete darkness.

Night vision cameras used in CCTV systems typically consist of near-infrared (NIR) and IR cameras with built-in IR illuminators. They are designed to allow the operator to view night scenes. The distance from which a CCTV system can detect objects at night depends on the capability of the camera components, such as the lens and sensor, as well as on the intensity of the IR illuminator used. The IR light emitted from these illuminators can be at wavelengths that are invisible to the human eye.

The primary determinant for whether a camera transmits an image in color or monochrome (varying tones of a single color) is the camera's image sensor. Monochrome cameras record images using light in NIR wavelengths outside the range of human perception (i.e., spectroscopic) while the image sensor of a color camera uses filters on the individual light

sensitive elements of the image sensor to limit that element to specific color wavelengths. These filters allow the sensor to detect and transmit color in addition to light intensity, which is what an unfiltered, monochrome sensor would detect. (Source: [CCTV student's handbook, Kristina Irelan and John Ehlers, 2005](#)).

Color cameras are used in daylight and well-lit night situations. There are many applications in which accurate reproduction of color is important. Color reference charts like that shown in Figure 3-2 provide an accurate color source for the selection/evaluation of cameras and optics. CCTV installers and technicians often use a color reference chart to assess the colors in an image. In addition, waveform generators and vector scopes are also used to measure system performance. It is important to remember that video monitor color reproduction is also critical.

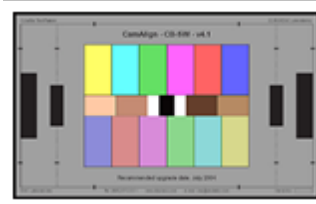

Figure (2- 14): Color Reference Chart

Source: CCTV student's handbook, Kristina Irelan and John Ehlers, 2005.

Monochrome cameras can capture images at night or in near-dark conditions that have more detail than the human eye can perceive. However, images captured with a monochrome camera during the day may lack some contrast and detail because the image is formed from visible and infrared light, which have different planes of focus. Monochrome image sensors are made mostly of silicon and germanium material and have two different spectral responses. This allows the image sensors to perform well in the infrared light region.

Thermal Imaging Cameras

Some operational environments may require a thermal imaging camera to detect through obstructions such as fog or smoke. Thermal imaging cameras detect infrared or heat radiation that is invisible to the human eye. Currently these cameras are sensitive to a temperature difference of one tenth of a degree Fahrenheit. Thermal imagers cannot detect through glass or water, but can provide an image through limited density fog or smoke.

Many thermal imaging cameras have built-in image processing to create images with improved contrast, like that shown in Figure 3-3. This provides better feature definition and sharper, clearer images. Thermal cameras are often mounted in gyro-stabilized, pan-and-tilt devices as well as on boats and helicopters for night surveillance in poorly lit areas. They are also available as small handheld units with built-in displays, which can be used in safety, security, and emergency responder applications. The image sensors in thermal cameras can degrade, so it is important to consult with the camera manufacturer to determine performance characteristics over time and to budget for the cost of periodic maintenance and replacement.



Figure (2- 15): Image from Thermal Camera

Source: CCTV Technology Handbook, Space and Naval Warfare Systems Center Atlantic, 2013

Miniature or Covert Cameras

Special applications may exist that require the installation of small, hidden cameras as part of a CCTV system. These cameras are not usually weather resistant, so they may require an external housing if they are to be used outdoors. These cameras are typically battery operated and may use built-in transmitters to provide a compact wireless solution. Organizations can choose from many types of miniature and covert cameras depending on their requirements.

Optional Camera Features

CCTV system can include a variety of optional features to meet the specific needs of the operational environment. Some of these common features are described below.

Auto Scan—Some PTZ cameras can be programmed to perform automated functions. Auto scan is the term used to describe a constant cycle of sweeping through the surveillance area.

Preset—A preset is a programmed orientation and lens setting, which a PTZ camera moves to either periodically or when a certain type of event occurs. For example, during an intrusion alarm, a camera can be preset to display the high-value assets in the surveillance area or to focus on the access point where the alarm was triggered.

Privacy Masking—A camera with privacy masking capability can selectively block portions of the video image for the purpose of protecting privacy. For example, PTZ cameras may be used to monitor a parking lot adjacent to an apartment building with the images of the windows in the building masked.

This is a feature of the system configuration (software or hardware) and can be complex and costly.

Slip Ring—A slip ring is an electrical connection that allows a PTZ camera to turn without twisting the signal/control cable. Slip rings can use light beams to optically transmit the image, or use a sliding brush contact on a base ring to create an electrical path. Slip rings tend to be sensitive to contamination and temperature changes. (Source: [CCTV Technology Handbook, Space and Naval Warfare Systems Center Atlantic, 2013](#))

Motion Detection—Cameras can be equipped with built-in motion detection features, which can be programmed to trigger an alarm if motion occurs within the FOV. The alarm can be programmed to trigger recording, alert an operator, or both. Motion detection features can also result in nuisance alarms if the environment has natural movement.

Backlight Compensation (BLC)—Some cameras have built-in BLC settings. BLC can compensate for the high contrast of images with a bright background and enhance the image detail accordingly. For example, BLC allows security personnel to see details of a person moving in front of a brightly lit window.

Digital Noise Reduction (DNR)—This feature is common for cameras intended to capture images in low-light or dark environments. DNR removes the noise (grainy appearance displayed as spots known as “raster”) from the video image. This makes the image clearer, brighter, and easier to interpret. Less digital noise can also reduce storage space requirements since there is less extraneous information in the video.

Mobile Compatibility—This application enables remote viewing of video on mobile devices such as smartphones, tablets, and laptops. Some remote viewing methods require special camera software or hardware while other methods and applications can be configured to connect directly with a camera and do not require a personal computer (PC).

Types of Image Sensors

CCTV system commonly uses charge-coupled device (CCD) or complementary metal oxide semiconductor (CMOS) image sensor technology. The smallest part of an image produced on a solid-state chip is the picture element, or pixel. Regardless of the sensor type, pixels are engineered in number, size, and

filtration to provide different resolutions, light sensitivity, and spectral responses.

Lenses

The lens on a CCTV system is the first element in the imaging chain, which consists of the lens, camera, transmission system, image management and analysis software, and monitor. The lens focuses light or IR energy onto the imaging sensor. A lens's role is to deliver an undistorted, evenly focused, accurate image to the imaging sensor. Systems that require superior quality images start with lenses engineered to produce a high-quality image for the imaging sensor. Other components of the imaging chain cannot compensate for an inferior lens.



Figure (2- 16): Representative CCTV Lens

Source: CCTV student's handbook, Kristina Irelan and John Ehlers, 2005.

Variables to consider when selecting a lens include the distance required to clearly focus on objects, FOV, size of the camera's image sensor, and lighting conditions. Lenses are identified by their focal length, usually stated in millimeters; largest aperture, usually stated as an f-number; and the size of the image sensor for which it was designed.

Types of Lenses

Lenses are available in three basic types: fixed focal length, varifocal (variable focal length), and zoom. The focal length of a lens is the distance between the optical center of the lens and the image plane. The lens focal length and the image sensor size determine the camera's FOV.

Fixed Focal Length Lenses

Fixed focal length lenses are built with one set, unchangeable, focal length. Such lenses are useful in situations where the camera remains in a fixed position and the requirements to observe an area do not change.

Varifocal Lenses

The focal length of varifocal lenses can be changed within a specific range; however, each change must be accomplished by hand at the camera. In addition, each time the focal length is changed, the iris and focus may also need adjustment. Varifocal lenses offer the flexibility of varying the scene content and are relatively inexpensive when compared to conventional zoom lenses. Once the focal length and iris are set, the camera will maintain the FOV. Varifocal lenses are identified by the focal length range, aperture range, and size of the image sensor the lens is designed for.

Zoom Lenses

Unlike the varifocal lens, the zoom lens is designed to maintain the focus setting throughout the focal length range. Zoom lenses in the CCTV industry are often built with integral motors to enable changing the focal length from a remote location. They are used on cameras that monitor different parts of a scene or can pan and tilt to monitor different locations. Zoom lenses are

identified by their focal length range, aperture range, and the size of the imaging sensor the lens is designed for.

Features of Lenses

A lens has certain components and characteristics that further determine its capabilities. These include the focal length, type of aperture and focus control, wavelength of light or energy the lens is optimized to transmit, and image sensor size the lens is designed for. Additionally, a camera's resolution and the impact of noise on the image being captured are critical to the overall performance of a CCTV system.

Focal Length and Imager Format

The focal length and size of the image sensor determine the angle from which the lens accepts light to focus on the image sensor. Different lenses of the same focal length are designed to create a focused image on sensors of different sizes. For example, surveillance cameras are built with image sensor formats of $\frac{1}{4}$, $\frac{1}{3}$, $\frac{1}{2}$, $\frac{2}{3}$, or 1 inch. These measures refer to the approximate diagonal measurement of the image sensor. Image sensor formats are denoted in inches, while lens focal lengths are measured in millimeters.

A lens should be selected to match the format of the image sensor so that the image formed on the sensor utilizes most of the available pixels. Lenses are

generally marketed for cameras with specific sizes of image sensors. The camera's FOV is a function of the lens's focal length and the size of the image sensor. (Source: [CCTV Technology Handbook, Space and Naval Warfare Systems Center Atlantic, 2013](#))

A lens built for large-format cameras may be usable on some small-format cameras; however, the reverse is not true as corners and edges of the image will appear darker. For example, a lens designed for a ½-inch sensor can work on a camera with a ⅓-inch sensor, but not the reverse. It is best to use a lens designed for the size of the image sensor in the camera.

3.2.2.2 Field of View

The image sensor size and the focal length can be used to determine the FOV. As shown in Figure 3-5, the FOV is the area seen by the camera and lens. This area is commonly calculated by a tool known as a lens calculator.

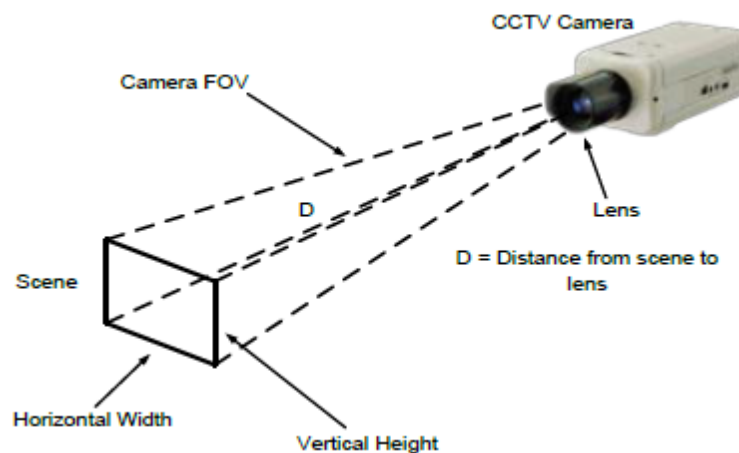

Figure (2- 17): Calculating FOV

Source: [CCTV student's handbook, Kristina Irelan and John Ehlers, 2005](#).

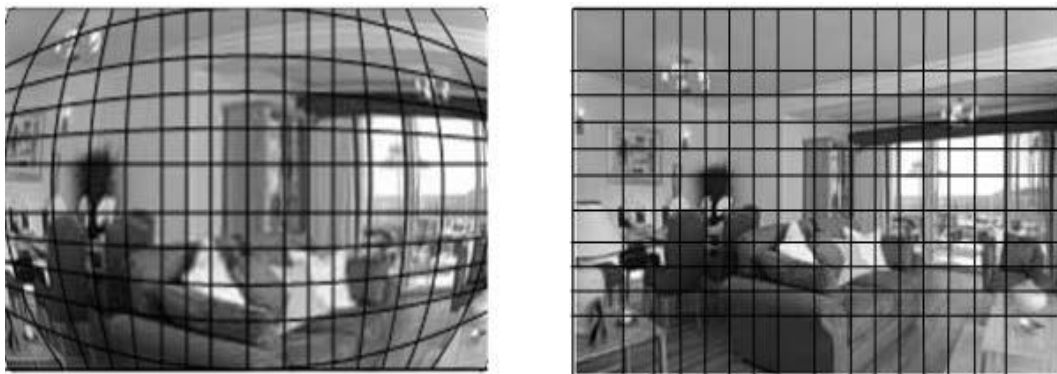

Figure (2- 18): Distortion Comparison

Source: [CCTV student's handbook, Kristina Irelan and John Ehlers, 2005](#).

Housing and Mounts

Part of designing and installing an effective CCTV system includes selection of the camera housings and mounts. Selecting CCTV housing and mounting hardware is directly related to the operational system requirements, which are developed during the design and procurement phases of a CCTV installation project. In any application, the housing and mounting hardware is selected on the basis of several criteria:

Environmental conditions, which include operating temperatures and weather conditions, such as humidity and corrosion;

Architectural considerations, which are important to the aesthetics of the hardware and can affect the architectural design or change the value of the property; and

Installation and other special considerations that match the installed materials to the system's intended use and planned maintenance.

The following hardware and mounting options are briefly described for comparison with system requirements. (Source: [CCTV Technology Handbook, Space and Naval Warfare Systems Center Atlantic, 2013](#))

Camera Housing

Fixed or PTZ cameras may require special housings or enclosures to ensure cameras are protected from elements such as extreme weather conditions and vandalism. Camera housings must be well-suited to the type of equipment installed. The housing will need to complement the CCTV system design and must not interfere with the desired FOV. System requirements, such as resistance to environmental conditions, tampering, and direct assaults, can dictate the

composition and style of the camera housing. The housings listed in this section provide enclosure protection capabilities for specialized applications.

Dome Enclosures—Indoor and outdoor domes are enclosures that protect CCTV equipment, often PTZ cameras, from the elements and provide discrete video surveillance by helping to conceal the direction the camera is facing. Domes can come with built-in heaters and fans as well as vandal-resistant hardened shells. They are usually spherical in shape to minimize wind load and vibration. Various styles and configurations are available. The optical dome must be able to withstand temperature extremes and not become brittle or cloudy with

exposure to solar and ultraviolet radiation. Materials that lose transparency with age in sunlight are unsuitable for outdoor camera use.

Sealed Housings—Special housings are available for cameras that must be placed in a hostile environment, or in areas where electrical components must be sealed to prevent a possible explosion. In these situations, sealed and/or pressurized camera housings are available, similar to that shown in Figure 3-9. A sealed housing uses gaskets to prevent contamination from the outside environment. Pressurized housings employ chemically inert nitrogen gas to replace the air inside the housing.



Figure (2- 19): Sealed Camera Housing

Source: CCTV Technology Handbook, Space and Naval Warfare Systems Center Atlantic, 2013

Impact-Resistant Housings—Impact-resistant, or anti-vandal, housings are often used in high crime areas or as components of military sensor systems. Impact-resistant camera housing bodies, like the example shown in Figure 3-10, are typically heavy-gauge steel, and the optical surfaces are thick acrylic or polycarbonate plastic. Some versions have a wire cage over the acrylic dome to provide greater protection. Observation is not hindered because the minimum focusing distance is several feet outside the wire cage.



Figure (2- 20): Impact-Resistant Housing

Source: CCTV Technology Handbook, Space and Naval Warfare Systems Center Atlantic, 2013

Tamper-Resistant Housings—Tamper-resistant housings are hardened protective housings similar to impact-resistant housings, with additional protection against the use of tools to vandalize the camera. A tamper-resistant housing is lockable and designed to withstand cutting, hammering, or prying.



Figure (2- 21): Tamper-Resistant Housing

Source: CCTV Technology Handbook, Space and Naval Warfare Systems Center Atlantic, 2013

Bullet-Resistant Housings—Bullet-resistant housings are made of impact-resistant materials. The window consists of at least one thick layer of a polycarbonate material.



Figure (2- 22): Bullet-Resistant Housing

Source: CCTV Technology Handbook, Space and Naval Warfare Systems Center Atlantic, 2013

Housing Features

Camera housings offer an array of features intended to extend the life as well as ensure the operational effectiveness of a CCTV system. Several of these features are described below.

Sun Shields—Exposure to high temperatures may adversely affect the life of the camera. Sun shields may be used to protect camera housings from direct sunlight, reducing the heat load on the camera and lens components.

Wipers—Some camera housings employ a wiper, similar to a vehicle windshield wiper, to keep the optical window of the housing clean. However, many experts dispute the effectiveness of wipers and recommend simply waxing the optical window periodically. The use of a wiper can cause debris to erode the optical surface. Wipers also add to the maintenance requirements. Rubber wiper blades must be replaced periodically, and washer fluid reservoirs must be kept filled.

Some systems use a durable film stretched over the optical surface of the housing. The film can be advanced from a cartridge to provide a clean optical path.

Heaters and Ventilators—Temperature differences between the interior and exterior of the camera housing may cause fogging, moisture problems, and icing. Therefore, certain camera housings may require additional hardware or capabilities to ensure the camera can operate under extreme conditions. Heaters and ventilators are often used to address environmental issues with cameras, although the need for additional electrical power increases the operational costs. Regular cleaning and maintenance can prevent problems with heated or ventilated camera housings. (Source: [CCTV Technology Handbook, Space and Naval Warfare Systems Center Atlantic, 2013](#))

Indoor Camera Mounts

The wide variety of CCTV mounting hardware and support equipment enables a security professional to tailor equipment capabilities to system performance requirements. Hardware options may become limited with an increase in specific requirements.

A camera can be mounted to a physical structure such as a wall or ceiling but may require different hardware for each application. Cameras come in many shapes and sizes and the mounting method can vary depending on the application and performance requirements. For example, a lipstick camera, often used for covert surveillance, can be placed in objects such as toys, clocks, or lights. In contrast, a nonfunctioning camera, often referred to as a “drone” or “dummy,” is simply mounted in a conspicuous location to deter unwanted activity.

Wall Mounts—Wall mounts use a bracket to support the camera similar to a shelf’s bracket. This mount often provides a method for adjusting the camera’s view or aim.

Pendant Mounts—Pendant mounts can be used to suspend the camera or equipment from a ceiling.

Corner Mounts—Corner mounts are used to attach a camera at a location where two walls meet at a right angle. There are two types of corner mounts: inner and outer. Corner mounts are often located near the ceiling to provide the best FOV.

Indoor Dome Camera Mounts—Dome mounts are sometimes mounted in highly visible areas. Domes can be partially recessed into a ceiling or mounted flush to a surface. Additionally, a dome unit can provide a platform for a PTZ camera or multiple fixed camera units. Finally, dome units should be located and installed with care to account for potential vibrations from nearby air conditioning and other electromechanical equipment.

Outdoor Camera Mounts

A variety of hardware is available to support and protect sensitive CCTV equipment from weather and the elements. Many of the same indoor mounting configurations are used for outdoor applications. Special mounting hardware is often required to match the styles and aesthetics of the exterior structures' existing trim elements. The mount/bracket should

accommodate the weight of the camera and housing. If using the camera outside, plastic fixtures should be avoided because of their tendency to deteriorate and become brittle when exposed to sunlight. In addition, brackets should be selected that allow for easy repositioning either with knobs or adjustable arms. This will allow for the flexibility to position and adjust the camera to improve the FOV. Two outdoor mounting options are detailed in this section.

Pole Mounts—Pole mounts can be used to raise the elevation of cameras and provide an unobstructed FOV. Often, the stability of the camera on a pole mount is sacrificed for height. Wind-induced movement of the mount may become more noticeable as the camera's height increases. Poles should be heavy duty, galvanized metal and must be completely stable. Pole mounts typically have stainless steel spring clamps for fastening to a variety of poles. Placement of the camera needs to be high enough to prevent tampering, while positioned appropriately for the intended FOV.



Figure (2- 23): Camera on Pan-Tilt Head with a Pole Mount

Source: CCTV Technology Handbook, Space and Naval Warfare Systems Center Atlantic, 2013

Corner Mounts—Corner mounts can be used for fixed or PTZ cameras, but are particularly helpful for PTZ cameras that need a large viewing angle as they pan through an area. Whenever mounts are located on or near the top of a building, the presence of adjacent air conditioning or other vibrating equipment should be noted as a potential source of blurring. Corner mounting brackets not only need to be secure and provide support for the camera, they must also comply with building codes.

Switchers and Multiplexers

In CCTV systems that have more cameras than monitors and recording devices, switchers and multiplexers are used to route the video signal. Switchers are simpler in concept than multiplexers. They can be set manually or automatically to send analog or digital video to a monitor or a recorder. Some switchers can send frames or fields from several cameras to a recorder in a sequential manner, recording a frame or field from each camera in sequence.

Multiplexers, invented in the 1980s, have capabilities not available in switchers. Multiplexers receive the analog video from several cameras and digitize the signal. Multiplexers can be programmed to prioritize the video from the different cameras according to rules. Cameras covering alarmed areas in an integrated security system may be prioritized so that their images are shown on a monitor and all frames recorded. Many multiplexers have imbedded motion detection and analysis software to support the recording or displaying of an image only when the software detects movement or some other phenomenon.

Many multiplexers can be used in networks controlled by computer systems. This flexibility, when combined with digital storage media instead of tape storage systems, blurs the distinction between multiplexers and other components like digital video recorders (DVRs) and network video recorders (NVRs). DVRs and NVRs not only perform the functions of multiplexers, but also include integral hard drive storage so that video is recorded as compressed digital data. Section 3.6 provides additional information on DVRs and NVRs.

Fully digital video systems, using network cameras, do not use switchers or multiplexers. The cameras send compressed digital video data directly to DVRs, or to monitors, over an Ethernet or

other electronic data network. Digital imaging and digital storage devices are becoming standard, but switchers and multiplexers offer a low cost, easy-to-

use alternative. (Source: [CCTV Technology Handbook, Space and Naval Warfare Systems Center Atlantic, 2013](#))

The primary advantage of using switchers and multiplexers in analog CCTV systems is the ability to route the video signal to multiple output devices. Section 4 addresses transmission and storage of video using IP networks. This section on switchers and multiplexers provides information about more traditional CCTV systems, which may use analog or digital components.

Switchers

Switchers are simpler in concept than multiplexers. They can be set manually or automatically to send analog video or a TV signal to a monitor or a recorder. Some switchers can send images from several cameras to a recorder in a sequential manner, recording an image from each camera in sequence.

Selecting the proper switcher largely depends on the number of cameras and monitors used and how the monitors will display the video. The simplest and most common devices used for small CCTV systems are the manual and sequential switcher. Most switchers provide a means to expand the CCTV system as new requirements are identified.



Figure (2- 24): Microprocessor-Based Switcher

Source: [CCTV student's handbook, Kristina Irelan and John Ehlers, 2005.](#)

As CCTV systems are built with greater numbers of cameras and monitors, switchers have become more powerful and versatile. Microprocessor-based switchers have a host of features such as:

- ✓ Camera and lens control;
- ✓ On-screen text;
- ✓ Password protection for programming;
- ✓ Partitioning of video for selected users;
- ✓ Interface capabilities with additional alarm and relaypanels;

- ✓ Remote viewing and control over IP networks;
- ✓ Macro programming and event timers;
- ✓ Integrated color bar generators for setting up monitors; and
- ✓ Networking for several switchers.

CCTV systems with large numbers of components need microprocessor-based switchers that can handle large numbers of video inputs and outputs. These are referred to as matrix switchers.

Matrix switchers offer versatility and some can handle over 4,000 cameras and 500 monitors. These switchers have the ability to control cameras, preset positions, or pan in the event of an alarm. Software programs have been developed to handle all types of camera, monitor, and recording situations. For example, user profiles and priorities can be created for as many as 100 operators and security personnel.

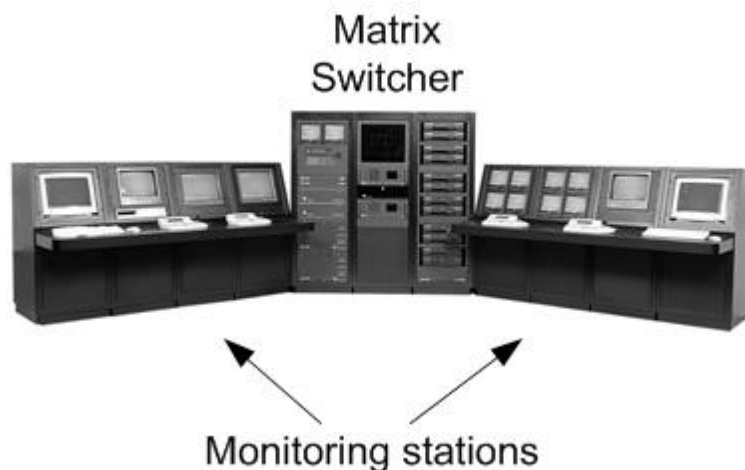

Figure (2- 25): Monitoring Station with Matrix Switcher

Source: CCTV Technology Handbook, Space and Naval Warfare Systems Center Atlantic, 2013

Matrix switchers can often be preprogrammed at the factory to suit a client's specifications, which will save considerable installation time. The ability to upgrade software and the availability of built-in diagnostics for the hardware are also important features in selecting equipment.

TRANSMISSION

The transmission system is an important component of the CCTV imaging chain that sends and receives video signals between the cameras, the processing system (i.e., DVRs, NVRs, and multiplexers) and the monitoring system (i.e. the display). Transmitting a strong video signal with low noise is vital to

producing a high-quality image on the monitor. Many problems associated with the quality of a CCTV system signal are attributable to the transmission system.

Many types of video transmission technologies are available today. High-quality components are needed to produce a high-quality result. The distance between a camera, monitor, and storage system is one of the most important criteria for deciding which means of transmission to use. IP-based systems are quickly gaining popularity as digital formats are becoming more common within CCTV systems. Other selection factors include installation costs, existing infrastructure, and availability of power. The options described below are available when determining the best suited transmission strategy. Any copper conductor (coaxial cable, twisted pair, etc.) exposed to an outdoor environment is susceptible to noise and lightning strikes. Lightning protection is an essential added expense and could degrade the video transmission if improperly installed and maintained.

Wired Transmission

Wired CCTV systems use cables to connect cameras to other CCTV components. Wired transmission can provide good quality video images with fewer instances of interference because cables are shielded. Cameras can be located far away from recording or monitoring equipment. Three types of wired CCTV systems are commonly used today: coaxial cables, UTP cables, and fiber optic cables. Transmission over a public telephone network is not advisable for CCTV

transmission due to the cyber security issues related to an open network; however, it is still used in some CCTV environments.

Coaxial Cable

Coaxial cable is the most common method of transmitting video signals from the camera to the monitor or other CCTV components. Coaxial cable consists of a single wire surrounded first by a nonconductive insulating layer (dielectric), then by a braided wire shield, and finally a plastic or rubber covering. This construction is shown in Figure 4-1. Note that CCTV applications require cable of the highest quality materials and manufacture. Both the center conductor and the braided shield must be copper. Aluminum foil-wrap shield, which is used in some consumer cable applications, does not meet CCTV requirements.

Direct-run distances of up to 2,000 feet can be achieved, depending on the gauge of the cable. Cable runs across greater distances are possible, although this requires the use of amplifiers inserted in the line between the camera and monitor.

Poor quality cable can have a negative impact on reliability and image quality. As transmission through coaxial cable is electrical, it is susceptible to Radio Frequency Interference (RFI) and EMI. It is possible for unauthorized persons to acquire the video signal either through these emissions or by directly tapping into the cable.

Care should be taken to properly ground the entire CCTV system when using coaxial cable or any other form of electrical signal transmission. Improperly grounded devices and cabling can result in poor quality video, loss of video, or a grainy image.

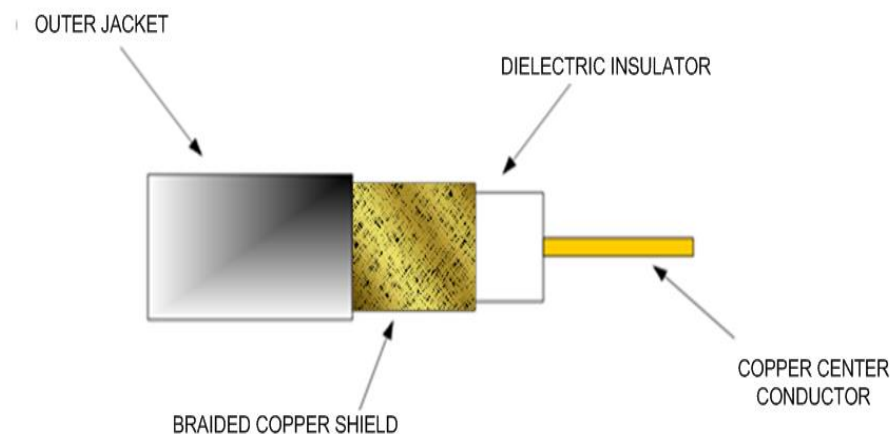

Figure (2- 26): Coaxial Cable Construction

Source: CCTV student's handbook, Kristina Irelan and John Ehlers, 2005.

UTP Wire

In some cases, running coaxial from a camera to a monitoring location is not practical and existing telephone wire can be used. For example, many buildings contain abandoned telephone lines, known as UTP, which can be used for a video system. This has several advantages: overall cost savings, low susceptibility to EMI or induction, no ground loop concerns, and ease of use. Also, telephone wire is smaller and much lighter than coaxial cable. It should be noted that using abandoned telephone wire beyond a facility's boundaries may require an approval process and service agreement with the telephone company.

UTP is comprised of two wires, twisted together. They are most often 22 or 24 American wire gauge (AWG) in size. When considering twisted pair for video transmission, unshielded twisted pair should be used to connect only one camera to a monitor or other device. Twisted pair must be dedicated solely to a particular video camera. While the per foot cost of twisted pair wire is lower than coaxial cable, signal conversion devices (transmitter and receiver) are required at either end of the wire run. Twisted pair wire can be used in runs of up to 5,000 feet. By using repeaters at least every 4,500 feet, twisted pair can be used over greater distances.

UTP, like other electrical transmission mediums, may be susceptible to various forms of interference and unauthorized acquisition of the signal. Performance is compromised when wires are routed through a telephone switching station. This type of wire should be used for continuous point-to-point transmission and routed through “punch down blocks” or splices. The connections should have solid, zero-resistance connections. (Source: [CCTV Technology Handbook, Space and Naval Warfare Systems Center Atlantic, 2013](#))

Fiber Optics

Fiber optic cable is lightweight and made up of a single spun glass or plastic fiber or a group of such fibers encased in a protective covering. It has a broad bandwidth, making it ideal for carrying video signals. Fiber optic cable can be used in runs up to 6 miles without amplification. The video signal coming from the camera must first go through a fiber transmitter which converts electrical signals to light impulses. A fiber receiver at the other end is required for conversion back into electrical signals.

Fiber optic cable is immune to RFI and EMI. In addition, grounding is not an issue with fiber optics and the cable is less susceptible, if not immune, to lightning strikes. Furthermore, in systems designed with top-of-the-line components, fiber optic cable has high cost to performance ratios. A single strand of single mode fiber can carry 32 channels of analog video. In low-end systems, the expense of fiber optic cable may not be warranted. Fiber optic cable requires extremely precise installation as the most minor damage to the cable or sharp bends can cause a major degradation of the signal.

Telephone Network

Another option for wired transmission of video signals is the telephone network. Although standard voice grade telephone lines do not have enough capacity to handle real-time full motion video, they still have value in specialized CCTV

applications. However, telephone lines are not recommended when the security of the video is a concern due to the cyber security vulnerabilities. An example can be seen in Figure 4-2.

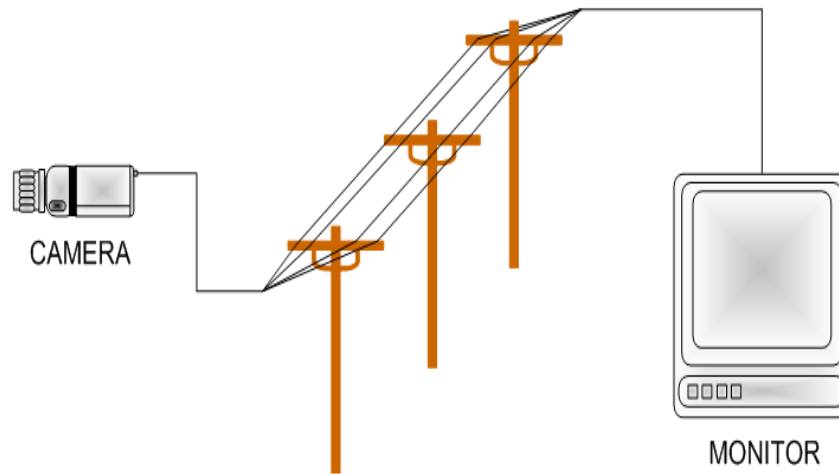

Figure (2- 27): Telephone Network Example

Source: CCTV Technology Handbook, Space and Naval Warfare Systems Center Atlantic, 2013

Some CCTV systems utilize slow-scan video imaging. Instead of using the standard 30 frames or images per second, slow scan video selectively skips images. In addition, each image may be a lower resolution than standard video. Digital compression can improve this transmission method considerably.

Ongoing improvements to compression technology have made it possible to send video images more efficiently across the telephone network. Currently, one video image can be transmitted every 6 to 12 seconds over standard phone lines at 28.8 kilobits per second (Kbps).

Integrated services digital network (ISDN) phone lines have a higher bandwidth because they combine two 56 Kbps channels for a total transmission speed of 112 Kbps. This high speed data transfer rate allows one video image to be transmitted in approximately one second.

Other high speed options are available, including T-1 or Fractional T-1 lines. The T-1 family of technologies allows for multiple 56 Kbps channels to be combined, thereby achieving larger bandwidths. Very large bandwidth lines, such as T-3 or E-1 lines, may be suitable for very large CCTV systems.

Category 5 Cable

Networks transmit video over Category 5 cable. The cable consists of four pairs of UTP 24-gauge copper wire with three twists per inch. The high number of twists per inch reduces the “crosstalk,” or EMI, between signals passing on the strands of the cable. Category 5 cables can be used to carry frequencies of up to 100 megahertz (MHz) and handle data rates up to 1,000 megabits per second (Mbps). The cables are terminated with an RJ45 connector and must meet the Electronics Industry Alliance/Technology Industry Association 568 Commercial Building Telecommunications wiring standard.

Wireless Transmission

Wireless options for transmitting video can be advantageous due to ease of installation, lack of cabling requirements, and assured mobility. There are some disadvantages of wireless systems such as the need for a dedicated frequency to transmit signals, signal interruptions, and signal interference. There are also increasing concerns over cyber security and the need for information assurance hardening. (Source: [CCTV Technology Handbook, Space and Naval Warfare Systems Center Atlantic, 2013](#))

SYSTEM INTEGRATION

The complexity and sheer number of components, software applications, inputs, outputs, transmission infrastructure, processing and storage devices, and customized settings of CCTV systems provide a wide range of possible configurations to meet an organization’s requirements. Integrating CCTV components requires thoughtful planning when new elements are brought online to achieve new capabilities or improve performance.

Systems Approach

Organizations should strive to have all security systems and their subsystems linked together to ensure the system’s components work together as a whole. Achieving systems integration is both a conceptual and a logistical challenge. Figure 7-1 illustrates the many different layers involved in an integrated security system.

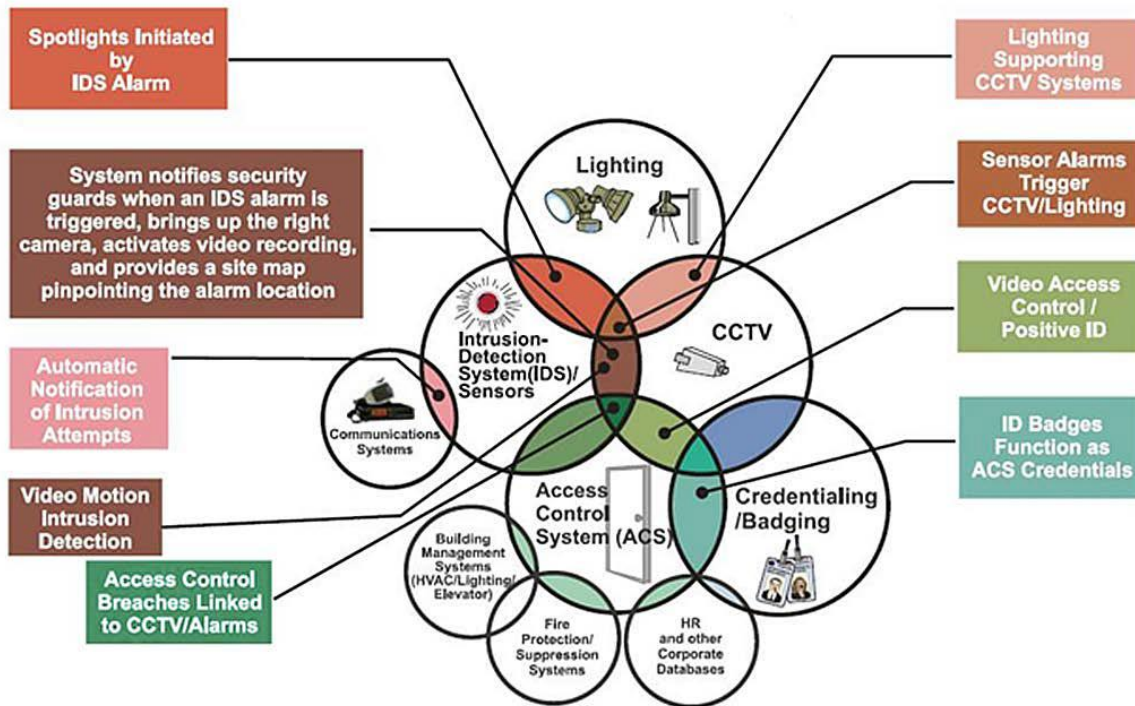

Figure (2- 28): Integrated Security System

Source: CCTV Technology Handbook, Space and Naval Warfare Systems Center Atlantic, 2013

Integrating CCTV Components

Newly designed CCTV systems have an advantage over existing systems because they can be designed from start to finish with current technology components from manufacturers that are easy to integrate. When selecting CCTV devices, organizations should consider future needs and requirements, such as the potential for expansion, scalability, integration, and upgrading.

Some additional technology considerations include:

- ✓ Ability to use a consistent hardware platform throughout the enterprise;
- ✓ Off the shelf software and equipment, not proprietary;
- ✓ Compatibility for data collection and storage;
- ✓ Advanced software graphical user interfaces (GUIs) to integrate controls and displays;
- ✓ Ability to create single security user profiles used by multiple security applications; and
- ✓ Vendor support to facilitate, test, and commission system integration.

2-2-5 VENDOR SELECTION CONSIDERATIONS

Selecting CCTV system vendors can be a challenge. Professional industry support is available from a host of companies, some of which offer a full suite of services and products. Others may offer more specialized services as designers, manufacturers, suppliers or authorized equipment dealers, installers, or integrators. The CCTV market evolves continuously with many vendors both entering and exiting the marketplace. Organizations may have internal expertise that can fill certain roles, but any new, expanded, or upgraded CCTV system will require engagement with some form of professional industry support.

Selection Criteria

Experienced vendors may provide invaluable expertise to organizations seeking upgrades of older technology CCTV systems. However, some new vendors may have more specialized expertise in a particular emerging technology.

Determining the most important criteria prior to selection is a fundamental step in finding the best suited vendor. Criteria can include the

vendor's previous experience and past performance with CCTV products/services, their level of sophistication with integration of CCTV components, technical support offered, and total cost. (Source: CCTV student's handbook, Kristina Irelan and John Ehlers, 2005).

Vendor Resources

Selecting a well-qualified and experienced vendor with the capabilities to meet desired qualifications will help increase the quality and performance of the overall CCTV system. The following organizations' websites provide information on CCTV system vendors, their related areas of expertise, and contact information:

- ✓ ASIS International;
- ✓ Security Industry Association;
- ✓ Security Magazine; and
- ✓ SANS Institute.

2-3 EMERGENCY AND FIRE SYSTEMS

2-3-1 WHAT IS FIRE?

Fire is the rapid oxidation of a material in the exothermic chemical process of combustion, releasing heat, light, and various reaction products. The flame is the visible portion of the fire. If hot enough, the gases may become ionized to produce plasma. Depending on the substances alight, and any impurities outside, the color of the flame and the fire's intensity will be different.

Fire needs three elements to ignite. These three elements are:

Oxygen: When Oxygen in the air combines with flammable vapours given off by Fuels they create a form of heat at a molecular level. Then, a source of ignition (a match or spark, say) can cause it to combust. Without enough Oxygen, ignition cannot happen. In the opposite way, if there is too much Oxygen then the vapours won't be concentrated enough to ignite. The ratio of vapour to Oxygen is known as the 'explosive' or 'flammable' limit and is different for each gas or vapour. (Source: [Handbook on Building Fire Codes, G.B. Menon Fire Adviser, 2005](#))

Heat: Combustion occurs when flammable vapours mix with air (Oxygen) and are ignited by a spark or flame. Solids give off flammable vapours by being heated. Certain solids such as paper or flour appear to ignite almost instantly. This is because they give off vapours and reach a flammable temperature almost immediately. In fact, fine dusts dispersed in the air can explode because they give off vapours and ignite so quickly it appear to happen instantly. Other solids like timber take longer to ignite because they are more dense and so don't give off flammable vapours so easily. Liquids are a bit different to solids. They are a lot more runny for a start. But, where solids need to be heated to give off flammable vapours, some liquids give off vapours even in cold weather.

Fuel: Fuels can take almost any form: Solids like wood, fabric, rubber and plastic. Liquids such as petrol, oil, cooking oil or even nail varnish remover. Gases like propane, butane and 'natural' gas. Different fuels burn at different rates and with different intensities.

The above mentioned elements create the “fire triangle”. Fire triangle in reality is a simple model for understanding the necessary ingredients for most fires.



Figure (2- 29): Fire Triangle

(Source: Handbook on Building Fire Codes, G.B. Menon Fire Adviser, 2005)

The Fire Triangle Theory has been accepted for many years. Today, this theory is modified to explain combustion or fire as a 4-sided figure, called a tetrahedron. A tetrahedron resembles a pyramid and offers a new element when considering combustion. The base of the pyramid represents the chemical chain reaction that occurs when the three other elements heat, fuel and oxygen are present in appropriate proportions. Vapors gases are released during the burning process and are carried into the flame. The heat from the flames drives the chemical reaction. Heat, fuel and oxygen are the three standing sides of the figure and all four elements must be present in order to support combustion.

2-3-2 Chemistry of Fire

MECHANICS OF COMBUSTION.

-From casual observation of a simple wood fire, it seems that the wood itself is burning. Actually, only the vapors given off by it supply the fuel that feeds the flames. Nearly all combustible materials, whether in a liquid or solid state, give off vapors when heated. Even paper, which is not ordinarily regarded as vapor producing, when heated gives off vapors which can be burned at some distance from the paper itself. Most solids must first be converted into a liquid state before vaporization takes place paraffin, for example, as in the case of a candle burning. The ignited wick melts the paraffin into a liquid, and the liquid flows into the wick and gives off vapor to feed the flame.

FLASHPOINT.-

Almost all oils must be heated until a vapor is given off before burning can take place. The temperature at which an oil begins to give off vapors that can be ignited is known as the flashpoint. Most lubricating oils must be heated to over 149 EC (300 EF) before they will flash. However, more highly volatile liquids such as gasoline, alcohol, naphtha, etc., have flashpoints so low they can be ignited readily at room temperature. The fire hazards that these liquids present are due to the fact that even at low temperatures they are constantly giving off highly flammable vapors.

The flashpoint of gasoline is -43 EC (-45 EF), and while the ever-present vapors are not visible to the naked eye, they may be observed by means of a shadow image produced by a powerful light. The flashpoint of a liquid, however, should not be confused with the temperature necessary to ignite the vapors, for unless a source of heat considerably hotter than the flashpoint of the fuel comes into direct contact with the vapors, the fuel will merely continue to give off vapors without burning. (Source: [Fire Fire Training Manual- I.C BRINDLE & COISGOTT, 2011](#))

1.3. OXYGEN REQUIRED FOR COMBUS-TION.-

The second essential factor in the process of combustion is oxygen. Without oxygen, even the most flammable vapors will not burn. Under normal conditions, a flame draws the amount of oxygen necessary to sustain combustion from the air. When the oxygen content of the air falls from normal 21 percent to below 15 percent, there is immediate extinguishment of practically all flames.

The part that oxygen plays in supporting combustion is illustrated in a cutting torch. When only the acetylene gas is used, there is no cutting effect on the metal, but when the oxygen valve is opened the torch readily cuts through the metal on which it is being used. Under normal conditions, the oxygen in the air combines with the combustible vapor in the direct proportion to sustain combustion. With the regulated flow of vapor in an open space, the ready mixture of the two elements is evidenced. The greater the flow of vapor, the greater the mixture with oxygen and the larger the flame. This action is caused by the heat of the flame. The hot-air currents rising from the flame create a draft suction that draws a steady flow of oxygen into the flame area.

With fuel at its flashpoint and vapors combining readily with air, the mixture may be regarded as in a state of readiness. Combustion, however, cannot occur until further heat is applied. An electric spark in some cases, or the heat of an heat.

IGNITION TEMPERATURE.-

There is a wide temperature difference between the flashpoint of a fuel and the ignition temperature; for example, the flashpoint (vapor given off) of gasoline is -43 EC (-45 EF), and the ignition temperature (heat necessary to ignite the mixture) is 257 EC (495 EF). A small flame can be thrown into lube oil which is at average room temperature and it will not burn, but with the addition of burning gasoline, vapors soon rise and burn to raise the temperature of the surrounding oil to the flashpoint. The rate of burning is governed by the surface area; i.e., only the fuel coming into contact with the air is consumed. The greater the surface area, the more readily oxygen reaches the vapors. The surface area of a material in proportion to its volume affects the readiness with which it will ignite. For example, if you cut two identical blocks of wood from the same piece of timber and reduce one of them to a pile of shavings, this greatly increases the surface area of the material; when a lighted match is placed against the solid block, it merely chars and absorbs the heat, while the same flame readily ignites the shavings. (Source: Fire Fire Training Manual– I.C BRINDLE & COISGOTT, 2011)

2-3-3 Classification of Fires

Definition and Types.-Classification of fires is the systematic arrangement in classes of the various substances that as fuels produce heat by combustion, as follows:

Class A: Ordinary combustible materials such as wood, cloth, paper, and some rubber and plastic materials.

Class B: Flammable liquids, gases, greases, and some rubber and plastic materials.

Flammable or inflammable (identical in meaning) liquids do not themselves burn or explode, but, as pointed out previously, the gases or vapors formed when they are heated and evaporated explode; that is, the change of state from liquid to gas must first occur. As long as they are in a liquid state with no vapors being given off, there is little or no hazard. For the more volatile liquids, such as gasoline, storage in a closed container is a necessity. In order for any vapor to

explode, it must have the correct vapor-air ratio, just as in the carburetor of a car. When the engine is flooded with gas, the mixture

is too rich and fails to ignite. The same holds true in gasoline storage. The danger is when the gases being poured from one container to another, thus giving the vapors the change to mix with the correct amount of air to form an explosive moisture. The same circumstances hold true with all flammable oils when enough heat is present to release vapors from the liquid.

Keeping in mind that a flammable liquid is not hazardous as long as It is not hot enough to give off vapors which can mix with the oxygen in air and burn, two things can be done: (a) The liquid can be cooled down to the point where no vapors are given off; and (b) the supply of oxygen can be blanketed out. Some flammable liquids give off vapors at temperatures ordinarily considered cold. For example, gasoline vaporizes at -43 EC (-45 EF) or lower.

Class C: Live electrical equipment.

When equipment is deenergized, extinguishers for class A or B fires could be used safely; however, in fighting an electrical fire there are two important things to be taken into consideration: namely (a) damage to the equipment far beyond what the fire could do, and (b) danger to the Individuals fighting the fire. To avoid these two possibilities, deenergize the circuit and use only the types of extinguishment recommended for class C fires.

Class D: Combustible metals such as magnesium, titanium, sodium, potassium, lithium, and zirconium. (Source: [Handbook on Building Fire Codes, G.B. Menon Fire Adviser, 2005](#))





CLASSES OF FIRES	TYPES OF FIRES	PICTURE SYMBOL
A	Wood, paper, cloth, trash & other ordinary materials.	
B	Gasoline, oil, paint and other flammable liquids.	
C	May be used on fires involving live electrical equipment without danger to the operator.	
D	Combustible metals and combustible metal alloys.	
K	Cooking media (Vegetable or Animal Oils and Fats)	

Figure (2- 30): Classification of Fires

(Source: Handbook on Building Fire Codes, G.B. Menon Fire Adviser, 2005)

2-3-4 PORTABLE FIRE EXTINGUISHERS

Types and Usage.-All extinguishers of a portable type act as a "first-aid" appliance for extinguishing fires in their incipient stage, and they cannot be expected to be effective after a fire has spread to involve a large amount of combustible material. The action of all extinguishers is by cooling the burning substance below its ignition temperature and by excluding the air supply (blanketing out the oxygen), or by a combination of these methods. Also, some types tend to inhibit oxidation by chemical action.

Extinguishers for Class A Fires.-

Multipurpose dry chemical Foamextinguishers Loaded stream extinguishers

Extinguishers for Class B Fires.-

Multipurpose dry chemical Foam Carbon dioxide (CO₂) Dry chemicals Loaded stream extinguishers Bromotrifluoromethane - Halon 1301

Extinguishers for Class C Fires.-

Multipurpose dry chemical Bromotrifluoromethane - Halon 1301 Carbon dioxide (CO₂) Dry chemicals

Extinguishers for Class D Fires.-Ex-tinguishers or extinguishing agents for class D fires shall be types approved for use on the specific combustible metal.

OPERATION.- This volume does not attempt to explain the complete operation of each individual fire extinguisher, as the directions for operation will be found on the equipment. All persons who may have to use an extinguisher should carefully read and adhere to the instructions placed on the extinguisher by the manufacturer. Upon initial assignment and at least annually thereafter, all employees designated to use fire extinguishers will be provided training in the use of such equipment. All other employees will be educated in the general principles of fire-extinguisher use and the hazards with incipient-stage firefighting at least annually. (Source: [Handbook on Building Fire Codes, G.B. Menon Fire Adviser, 2005](#))

INSPECTION AND MAINTENANCE.-

General.- Portable extinguishers shall be maintained in a fully charged and operable condition, and kept in their designated place at all times when they are not being used. Each extinguisher shall be equipped with a tag for registering inspection date. Aluminum tags on which the date can be punched are preferred for a lasting record.

Inspection.- Inspection is a quick check that an extinguisher is available and will operate. Extinguishers shall be inspected monthly, and the following items shall be checked:

- (1) The extinguisher shall be in its designated place.
- (2) Access to, or visibility of, the extinguisher shall not be obstructed.
- (3) The operation instructions on the extinguisher nameplate shall be legible and face outward.
- (4) Any seals or tamper indicators that are broken or missing shall be replaced.
- (5) For water types without gauges, their fullness shall be determined by "hefting."
- (6) Any obvious physical damage, corrosion, leakage, or clogged nozzles shall be noted.

(7) Pressure-gauge readings when not in the operable range shall be noted.

The date the inspection was performed and the initials of the person performing the inspection shall be recorded. When an inspection reveals that tampering has occurred, or that the extinguisher is damaged, impaired, leaking, under- or overcharged, or has obvious corrosion, the extinguisher shall be subjected to applicable maintenance procedures.

Maintenance.-Maintenance is a "thorough check" of the extinguisher intended to give maximum assurance that an extinguisher will operate effectively and safely. It includes a thorough examination and any necessary repair or replacement. Maintenance shall be performed at regular intervals, not more than 1 year apart or when specifically indicated by an inspection. Any extinguishers removed from the premises to be recharged shall be replaced by spare extinguishers during the period they are gone. Refill all extinguishers as soon as they are used.

Stored pressure-dry chemical extinguishers that require a 12-year hydrostatic test will be emptied and subjected to applicable maintenance procedures every 6 years. Dry chemical extinguishers having non-refillable, disposable containers are exempt from this requirement. (Source: [Fire Fire Training Manual– I.C BRINDLE & COISGOTT, 2011](#))

2-3-5 Application of Firefighting Equipment(Portable and Fixed)

Water Extinguishing Systems. Water was man's first means of fighting fire and is still one of the best all-around weapons. However, it should be borne in mind that water can be damaging to insulated conductors and windings, such as in motors and generators, and to switchboard wiring. The damage to the insulation from soaking may require extensive drying out or rewiring operations, and the damage from water may be as much or more than the damage caused by the fire itself. For this reason, water should be used on a fire of this type only as a last resort. Water may also be undesirable from the standpoint that it is sometimes difficult to deenergize all circuits with which the water might come in contact. Since water's effectiveness depends on the speed with which it is applied to the fire after the fire is first discovered, the firefighting force must function as a well-organized team in laying the hoses in order to get the water on the fire.

The male end is always run in the direction of the fire. This is done because all nozzles and fittings are equipped with female couplings. By having the female end on the outside of the coil, the correct end is always at the correct place for coupling, and the threads on the male end are protected against abrasion or damage. To unroll the hose, the foot is placed on the female end, the male end is snapped up sharply and run toward the fire. To roll the hose in a coil, the length is first laid straight, then doubled over, placing the male end on the top about 1.2 m (4 ft) from the female end. Grasped at the fold, the hose is rolled tightly as slack is taken up. Care should be taken to obtain an even, compact roll. Coiled in this manner, the ends are in the correct position, the male end always on the inside. (Source: [Fire Fire Training Manual– I.C BRINDLE & COISGOTT, 2011](#))

Handling of Fire Hose.-The hose must be unrolled so that male and female ends are in the correct position for coupling. All couplings must be made tightly to guard against leakage and loss of pressure. The hose must be spread out or laid so that it will not kink or tangle when the line is advanced toward the fire. Unless all these tasks are performed quickly and efficiently, valuable time will be lost that may mean the difference between a fire being quickly extinguished and a fire getting out of

control. Hose, when coiled as illustrated in figure 2, can be run out without tangling or kinking.

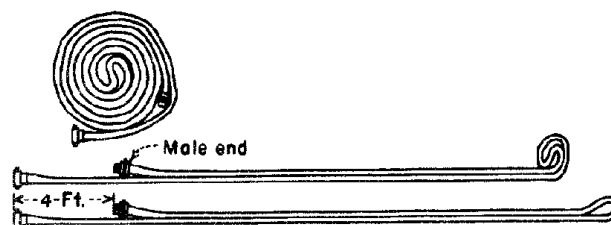

Figure (2- 31): Coiling fire hose

(Source: [Handbook on Building Fire Codes, G.B. Menon Fire Adviser, 2005](#))

2-3-6 FOAM EXTINGUISHING SYSTEMS.-

General. Firefighting foam is a mass of gas-filled bubbles which is lighter than flammable liquids. The foam can float on all flammable liquids and produces an air-excluding, cooling, continuous layer of vapor-sealing, water-bearing

material for purposes of halting or preventing combustion. Two main types of foam are available. These are low- and high-expansion foam as discussed below. The following general rules apply to the application and use of ordinary air foams:

- (1) Most foams are adversely affected by contact with vaporizing liquid extinguishing agents and by many dry chemical agents. These materials should not be used simultaneously with air foams. Gases from decomposing plastic materials have a similar breakdown effect on foams.
- (2) Foam solutions are not recommended for use on electrical fires as the foam is conductive.
- (3) High-expansion foam can seem to completely submerge and apparently extinguish fires, while the fire continues to burn quietly beneath it. This can occur when burning vapors beneath the foam support the foam blanket on heated air.

Low-Expansion Foam. The normal expansion ratios for low-expansion foam range from 4:1 to 12:1. The expansion ratio is the volume of foam generated, divided by the volume of solution used. The primary method of extinguishment with low-expansion foam is smothering, although cooling is a factor. The minimum foam depth for extinguishing a fire is about 6 mm (1/4 in) with an average depth of 76 mm (3 in) or more.

High-Expansion Foam. The normal expansion ratios for high-expansion foam range from 100:1 up to 1000:1. The primary method of extinguishment is the smothering and cooling effect of water. High-expansion foam is particularly suited as a flooding agent for use in confined spaces, for transporting wet foam masses to inaccessible places, and for volumetric displacement of vapor, heat, and smoke.

Limitations of Foam. Foams are primarily used for control and extinguishment of fires involving flammable or combustible liquids, and the following criteria must usually be met for the foam to be effective:

- (1) The liquid must be below its boiling point at the ambient condition of temperature and pressure.

(2) If foam is applied to liquids with a bulk temperature higher than 100 EC (212 EF), the foam forms an emulsion of steam, air, and fuel. This may produce a fourfold increase in volume.

(3) The foam must not be highly soluble in the liquid to be protected, and the liquid must not be unduly destructive to the foam.

(4) The liquid must not be water reactive.

(5) The fire must be a horizontal surface fire as falling fuel fires cannot be extinguished by foam unless the fuel has a relatively high flashpoint and can be cooled to extinguishment by the water in the foam. However, some foams are capable of following a flowing fuel fire. (Source: [Handbook on Building Fire Codes](#), G.B. Menon Fire Adviser, 2005)

2-3-7 CARBON DIOXIDE EXTINGUISHING SYSTEMS.-

Principle. The use of CO₂ as an extinguishing agent is based on the principle of using an inert gas to reduce and displace the oxygen content of the air. Most fires where there are no flowing embers to maintain a high degree of heat for reignition can be extinguished by a reduction of the oxygen content from the normal 21 percent to 15 percent. Since CO₂ is heavier than air, it has the ability to penetrate into loose material and confined spaces where water or foam might not. The rapid expansion of the gas on discharging produces a refrigerating effect, as indicated by the CO₂ snow, which has a temperature of minus 79 EC (-110 EF). This snow turns into gas and in the process absorbs heat from the surrounding atmosphere.

CARBON TETRACHLORIDE, CHLORO- BROMOMETHANE AND

INVERTING-TYPE EXTINGUISHERS- The use of carbon tetra- chloride and chlorobromomethane extinguishers is not allowed in any form at Reclamation installations because of their toxic and corrosive insulations. Inverting-type fire extinguishers, such as self-generating soda acid, self- generating foam, or gas-cartridge, water-type, portable fire extinguishers which operate by inverting the unit to initiate an uncontrolled pressure generating chemical reaction to expel the agent, are prohibited at Reclamation facilities because their shells are subject to metal fatigue and creep at the seams of construction which can cause failure of the units and may injure the operator. fire situation are the availability of proper

DRY-CHEMICAL EXTINGUISHERS.- areas and proper education of employees

Principle and Uses. Dry-chemical extinguishers expel a finely powdered dry chemical which, on striking flame, releases many times its volume in nontoxic fire-extinguishing gases similar to CO₂. The powder consists principally of bicarbonate of soda which has been chemically processed to make it free-flowing. The extinguishers contain a cartridge of CO₂ or nitrogen (depending on size) to expel the dry chemical. These extinguishers can be used for electrical fires, both in rotating machinery and other equipment, since the seconds in the 159-kg (350-lb) size. Effective range of the compound stream is from 10.7 to 13.7 m (35 to 45 ft).

Safety Requirements. Where there is a possibility that personnel may be exposed to a dry-chemical discharge, suitable safeguards shall be provided to ensure prompt evacuation of such locations, and also to provide means for prompt rescue of any trapped personnel.

2-3-8 Emergency Action Plan and Cause, and Prevention of Fires

EMERGENCY ACTION PLAN. The most important factors to consider in providing adequate employee safety in a exit facilities to assure ready access to safe as to the actions to be taken in a fire emergency.

For each workplace, an emergency action plan will be established in writing and shall cover those actions necessary to ensure employee safety from fire and other emergencies.

- 1) Emergency escape procedures and emergency escape route assignments;
- (2) Procedures to be followed by employees who remain to operate critical point operations before they evacuate;
- (3) Procedures to account for all employees after emergency evacuation has been completed;
- (4) Rescue and medical duties for those employees who are to perform them;
- (5) The preferred means of reporting fires and other emergencies; and
- (6) Names or regular job titles or persons or departments who can be contacted for further information or explanation of duties under the plan.

An alarm system which complies with OSHA (29 CFR 1910.165) will be established for alerting employees and/or fire-brigade members.

Before implementing the emergency action plan, each plant will designate and train a sufficient number of persons to assist in the safe and orderly emergency evacuation of employees.

The emergency action plan will be reviewed with each employee covered by the plan at the following times:

- (1) Initially when the plan is developed,
- (2) Whenever the employee's responsibilities or designated actions under the plan change, and
- (3) Whenever the plan is changed.

FIRE PREVENTION. Many fires start as a result of poor housekeeping, not only in the home but in many supposedly fireproof structures. Many building fires can be traced to oily rags and other materials (subject to spontaneous ignition) discarded or inadvertently dropped onto inaccessible places, such as an oily rag falling onto heating system pipes. The temperature of the pipes starts the process of vaporization, and heated vapor entrapped in the rag accumulates and builds up a higher temperature. In time, the ignition temperature of the oil rag is reached and a fire is under way.

A high standard of cleanliness and order is perhaps the most important single element in fire prevention. Simple daily tasks such as regular disposal of wastepaper and other combustible waste are of utmost importance. Waste cans should be metal containers with lids. Also, oily mops, dust rags, etc., should be kept in fire-resistive storage enclosures since they are subject to spontaneous ignition.

Good housekeeping is as essential outdoors as it is within structures. Rubbish and waste should not be allowed to accumulate where it can serve to aid in the spread of fire. Dry weeds or grass around buildings present a fire hazard.

Another likely place for a fire to start is in a locker room where men have left oily clothes or clothes smeared with paint. Matches left carelessly laying around, particularly where there are mice or rats, constitute a fire hazard.

Other items to watch for as a possible source of fire are hot bearings, exposed light bulbs near flammable material, sparks flying from grinding wheels, dust and lint collecting oil in blower and ventilating systems, and careless disposal of cigarettes and matches.

Gasoline fires or explosions are often caused by static electricity, particularly during loading or fueling operations around service stations or on tank cars and trucks. The electric charge is generated by friction of the flowing liquid. When the nozzle is grounded by contact with the tank, the electric charge drains off to the ground; but when the nozzle is not in contact and no grounding exists, static charge is likely to build up and eventually discharge to ground through the shortest path. Since the mouth of the tank is the nearest metal conductor, a spark hot enough to ignite a vapor-oxygen mixture will span the gap between the nozzle and the tank. (Source: **Fire Fire Training Manual– I.C BRINDLE & COISGOTT, 2011**)

COMMON CAUSE OF ELECTRICAL FIRES.

-The more frequent causes of electrical fires are arcs, sparks, overheating, and over loading a circuit. When a current-carrying circuit is interrupted, intentionally or otherwise, an arc is produced such as that formed when a knife switch carrying load is opened. Such arcs have temperatures high enough to ignite any combustible material that may be in the vicinity, as well as through hot metal from the fused conductor. The amount of heat generated in a conductor is in direct proportion to the resistance of the conductor and to the square of the current. For this reason, conductors used to carry power to electrical equipment should be large enough (of low resistance) to carry the load without overheating. Metals such as copper and aluminum are used for this purpose. In many instances, electrical fires are caused by temporary or inadequate wiring jobs which are in violation of the National Electrical Code, which limits the current a conductor shall carry and the type of insulating covering.

Some of the major causes of electrical fires are:

- (1) Use of fuses too large for the circuit they are protecting, or a circuit breaker with too high a setting.
- (2) Adjustable-type circuit breaker switch a blocked tripping element.
- (3) Pennies inserted behind plugfuses.

- (4) Nails or bolts substituted in place of cartridge fuses.
- (5) Refillable fuses in which additional strips have been placed.
- (6) Corrosion of fuses, circuit breakers, or conductors.
- (7) Insulation of conductors deteriorated from age or mechanical injury and exposure to heat, moisture, or vapors.
- (8) Joints not properly soldered and taped.
- (9) Burned and pitted contacts.
- (10) Overheating due to poor contactor

2-3-9 Care and Inspection of Firefighting Equipment

Training.-Fire protection, regardless of how good the equipment may be, is entirely nullified if equipment is not kept in operative condition at all times. Therefore, the importance of proper care of equipment and routine inspection to make sure the equipment is kept in perfect working order for instant use cannot be overemphasized. (Source: [Handbook on Building Fire Codes, G.B. Menon Fire Adviser, 2005](#))

Foremen and other employees should be instructed in the use of all fire equipment so that they will not only be able to bring it quickly into action in the event of fire, but also so that they will realize the importance of its being accessible and unobstructed at all times. Trained employees will not allow firehose or extinguishers to become obstructed by piles of construction materials, supplies, or permanent equipment, or allow fire doors to become blocked open. They will see that aisles are kept clear so that there will be less chance of accidents occurring. Foremen and employees who are instructed in the dangers of poor housekeeping and defective electrical equipment will see to it that clean conditions are maintained, oily rags properly disposed of, and defective wiring, etc., repaired at once.

INSPECTIONS OF EQUIPMENT.-Periodic inspections should be made by capable personnel, preferably two or more, who should alternate in making the inspections. Portable extinguishers shall be inspected as required by section 3.3. Automatic foam or CO₂ systems should be checked to see that they are ready for operation in event of fire.

Fire Doors and Shutters.- All fire doors and shutters and their hardware, including fusible links, should be in good condition. The action of automatic sliding doors should be checked by raising the counterweight by hand. The guides of rolling steel doors should be checked. Any paint on fusible links should be scraped off. Rolling doors should be given an occasional operating test by disconnecting the fusible link. When checking over the fire doors, note if there are any openings in firewalls not properly protected by the fire doors or shutters.

Floor Drains.-Floor drains are provided in some instances to drain the floors of water promptly in event of fire or sprinkler leakage. They should be kept clear at all times. (Source: [Handbook on Building Fire Codes, G.B. Menon Fire Adviser, 2005](#))

Antifreeze Pump-Tank Extinguish-ers.-Antifreeze pump-tank extinguishers should be frequently inspected, kept full at all times, and refilled immediately after use. In recharging, it is desirable that all parts be washed thoroughly with water and the water drained through the hose. It is essential to draw all water from the hose to prevent freezing or clogging of the nozzle. It is recommended that after recharging and during inspections, the pump be operated several times, discharging the liquid back into the tank. Where an antifreeze solution is used, the specific gravity of the solution should be determined periodically with a hydrometer so as to ensure against freezing at the lowest temperature that may be encountered. Liquid which has evaporated or is used must be replaced. Pump tanks should be kept tightly covered so as to retard evaporation.

This type of extinguisher should be examined as to condition of operating parts at least once yearly, and during this examination, a drop of oil should be put on the piston-rod packing. Manufacturers of this type of extinguisher are now marketing a special antifreeze charge for these devices. Common salt or chemicals other than those specified must not be used in these extinguishers for any purpose; they cause corrosion.

Carbon Dioxide Extinguishers.-Carbon dioxide extinguishers should be weighed at least once every 6 months to detect leakage or accidental release and must be recharged immediately after use, even though only partially discharged. CO₂ cylinders should not be lifted by the neck or cap of the cylinder during weighing or handling procedures as the cylinders are not structurally designed to be supported by the neck. If an extinguisher shows a loss of weight of less

than 10 percent of the rated capacity stamped on it, it need not be discharged or refilled; the contents do not deteriorate with age. The extinguisher should be sent to the manufacturer or his authorized agent for recharging. A close check on the condition of rubber and composition hoses should be made, especially where they are exposed to the sun, as in outdoor installations.

Dry-Chemical Extinguishers.-Dry-chemical extinguishers are filled with a compound consisting principally of bicarbonate of soda which has been chemically processed to make it waterproof, noncorrosive, nonconducting, and free flowing. The extinguisher contains a cartridge of carbon dioxide or nitrogen used to expel the dry compound. The carbon dioxide or nitrogen cartridge should be removed and weighed every 6 months. It should be replaced if it shows loss of weight. It is not necessary to be removed to make sure it is full and there is no caking or moisture present. Compound and cartridges other than those furnished by the manufacturer should not be used, and recharging instructions should be carefully followed. A quantity of dry compound and spare cartridges should be kept on hand for immediate recharging after use. Care should be exercised that the extra compound is not contaminated by foreign materials.

Wheeled-Type Units.-Large wheeled-type units of carbon dioxide are available, and the common size for these devices are 23, 24, and 45 kg (50, 75, and 100 lb). The procedure for recharging and maintaining these devices is similar to the procedure on the small devices. Care must be taken in considering these devices to see that the doorways are wide enough to permit passage of the extinguisher from one room or section to another. In switchyards and any other type of structure on which protection is necessary, there should be concrete runways for the large-wheeled units where they are equipped with steel wheels. Where the large-wheeled units come equipped with pneumatic tires, a check should be maintained to see that these tires are properly inflated. Where it is necessary to store these

should be provided to keep the units out of the sun and weather to prevent deterioration of the rubber hose and tires.

Dry-compound extinguishers of the 45- to 159kg (100- to 350-lb) size must be inspected every 6 months to ensure that the nitrogen pressure is available. This is done by pressure gauges forming a part of the extinguisher, similar to those

found on an acetylene welding unit. This extinguisher must be recharged and hose cleaned out by blowing out compound when used or partly used, and the nitrogen cylinder replaced by one fully charged when the pressure gauge shows less than 454 kg (1,000 lb). Compound furnished by other than the manufacturer should not be used. The recharging instructions should be carefully followed. A quantity of dry compound and a spare nitrogen cylinder should be kept on hand for Immediate recharging after use.

Hose. Successful firefighting depends upon adequate fire streams. The fire-hose is a connecting link between the water supply and the fire, and of all firefighting equipment, it is the most essential. The life of firehose may be as short as 3 years or as long as 15 years. Under average fire conditions and with proper care, hose should be serviceable for a period of at least 7 years. Hoses requiring replacement should be replaced with lined hose.

The principal sources of damage to hoses are mechanical Injury, heat, mildew and mold, acid, gasoline, and oil. Tears, snags, and abrasions from dragging hose over ground or rough surfaces account for much damage to hose. Hose on racks, reels, or on firetrucks should be reloaded from time to time. This is to change the hose and prevent kinks which may damage the hose. A satisfactory method of storing hose, not in actual use, is in rolls stored horizontally. All hoses on racks and reels in powerplants or warehouses should be completely unrolled or unfolded at least annually. All racked hoses will be reroled using a different folding pattern. If drying facilities are available, they should be used.

2-4 PREVIOUS STUDIES

STUDY 1:

Research Title: (Source: a simple and reliable touch sensitive security system, Adamu Murtala Zungerul, 2014.)

This research focuses on detection of unauthorized access to residential and commercial buildings when the residents are far away from the access gate of the house. The system is a simple and reliable touch activated security system and uses sensor technology to revolutionize the standards of living. The system provides a best solution to most of the problems faced by house owners in their daily life. Due to its simple electronic components nature, it is more adaptable and cost-effective.

Similarities and differences:

- This study is consistent with the present study because it was interested in studying the security system in buildings and the same statistical methods were used to analyze the data.
- The study differed from the current study in that it is focusing on one of the systems that in the current one sand it is more detailed.

STUDY 2:

Research Title: (Design and Development of a House-Mobile Security System, Ashraf Elfasakhany, Jorge Hernández, Juan Carlos García, Mario Reyes, Francisco Martell, 2014)

The objective of this research was to design, develop and implement an alarm system that triggers the alarm and alerts the owner via a mobile text message if the house has been opened or an attempt has been made to open it illegally. The system will also feature two different forms of activation/deactivation and will automatically open or close the door for the user. The advantages of this house-mobile security system (HMSS) are its high security level, robustness, low cost and ease of use (uncomplicated) and that there is no distance limitation for contact.

Similarities and differences:

- This study is consistent with the present study because it was interested in studying the security system in buildings and the same statistical methods were used to analyze the data.

- The study differed from the current study in that it is focusing on home security and it is integrated to a mobile system and it is more detailed.

STUDY 3:

Research Title: (Study of fire-fighting in the industrial buildings, Tasneem Abdallah Nooraldeen, 2017)

The study represents a number of solutions to reduce the factories fires in Khartoum, fighting them and educates workers and training them on importance of knowledge and to control of fire and means and methods and to contribute to provide sufficient information for this area to the library.

Similarities and differences:

- This study is consistent with the present study because it was interested in studying the firefighting systems in buildings and the same statistical methods were used to analyze the data.
- The study differed from the current study in that it is focusing on industrial buildings only and has only one system to study.

CHAPTER THREE: RESEARCH METHODOLOGY

3-1 GENERAL INTRODUCTION

This chapter deals with the research methodology used in answering research questions and achieving research objectives. This chapter reviews the analytical descriptive approach, and the reason for its selection is that this approach is based on describing a phenomenon to reach the causes of this phenomenon and the factors that control it. The method of the survey, which was used to answer the main question of the research which are:

Are the safety and security systems applied in buildings according to the standards?

What are the main dangers that threat the occupants and the reasons that they occur?

Are the safety and security systems working efficiently?

3-3 Steps of the study:

The method is based on several basic steps. The first of these steps is to determine the sample of the study, its determinants, type and number. A group of buildings were selected in Khartoum State because the accidents in these buildings are a great danger and a worrying concern to the population and officials at all levels, Because of the high number of occupants and the variety of buildings use in Khartoum.

Defining the concepts to be studied:

Each building was studied according to the availability of means of safety and security, including access control system, CCTV system and firefighting system.

The implementation of these means and systems in these buildings.

Procedures of the survey: The location of buildings, buildings function, number of floors and the people who completed the data form were identified.

Data Analysis: Data forms were compiled and data analysis was performed by the SPSS program

3-4 Methodology tools:

The tools used to conduct the study are the direct observation during the visits, as well as taking pictures of the systems implemented in these buildings, comparing them with the systems mentioned in Part Two to ensure their conformity with the standards, in addition to interviews with the employees of the Ministry of Planning, In the state of Khartoum and its places of presence, and meet the employees of the engineering department in the Ministry of Civil Defense to know the Civil Defense Law and to know the technical and administrative measures and procedures provided for by the civil defense to prevent the exposure of disasters and reduce the harmful effects on facilities, property and the lives of citizens, and used the questionnaire as a key tool for collecting information.

3-5 Description of the questionnaire

- The questionnaire was designed according to the rules of writing the questionnaire. The questionnaire was introduced, explained the purpose of it and included the deadline for closing period of answering it. - The questions of the questionnaire were accurate, clear, short and did not need to reflect in depth because the respondent may not be able to answer and was using the closed answer style yes or no because it is characterized by ease and blockade. It was divided into six groups each has 3 to 7 questions. The questionnaire contains access control system, CCTV system and firefighting system Sample study was conducted randomly from the study community where the researcher distributed the questionnaire number of electronic distribution. (Khartoum, Bahri, Omdurman) and includes several buildings. This was presented to the supervisor and presented to a number of engineers to ensure that the questions were clear. And the approval of the questionnaire - the questionnaire was distributed in two ways directly by giving the questionnaire directly to the sample or published on social networking sites.

3-6 Statistical Processing Methods

After completion of the response to the study data by the study sample, these data were coded and entered into the statistical package program (Statistical Package for Social Sciences) (SPSS), the data were analyzed and then processed using the following statistical methods:

- Alpha-Cronbach coefficient to measure stability of the study tool.

- Frequencies and percentages were calculated to identify personal and functional characteristics of sample individuals.

3-7 Test Reliability and Stability Tool Study

The validity of the questionnaire is to ensure that it will measure what it is prepared for, and the clarity of its paragraphs and its vocabulary, so that all the elements that must be included in the analysis are understandable to who use them.

The accuracy of the internal consistency (Alpha Kronbach) is a coefficient of scale or index of the stability of the test (questionnaire), and means that the answer will be one if repeated applied to the same people, and to verify the internal consistency and consistency of the study axes the researcher used Alpha Cronbach.

Test the honesty and consistency of the questions of the means of positive protection:

Table (3- 1): Total Cronbach's Alpha

Source: Researcher

Cronbach's Alpha	N of Items
.831	26

Table (3- 2): Total Correlation and Cronbach's Alpha

Source: Researcher

	Corrected Item-Total Correlation	Cronbach's Alpha if Item Deleted
Have you been in trouble to access the building?	.212	.831
Have you been roped in the building before?	.212	.833
If yes: How many time have you been roped?	.200	.859
Did you find out who roped you?	.237	.852
Do you have a backup power	.245	.831

supply?		
Do you have an emergency plan?	.358	.830
Do you have access control system?	.824	.827
What type?	.746	.804
How many doors are controlled? (Internal)	.724	.805
How many doors are controlled? (External)	.649	.810
Does the system integrate with CCTV?	.819	.799
Do you have CCTV camera system in the building?	.511	.820
If yes, where are the cameras applied?	.835	.803
Location of cameras	.835	.803
Camera mounting	.819	.800
Total number of cameras in the system (Internal)	.789	.801
Total number of cameras in the system (External)	.740	.805
Have the building been on fire before?	.234	.832
If yes, what is the cause of the fire?	.248	.856
Is there a designated smoking area provided with adequate ashtrays?	.380	.830
Are there emergency exits?	.358	.830
Are there any means of fire detectors?	.358	.830
are there any means of emergency alarms?	.358	.830
Are there fire extinguishers?	.358	.830
Are the locations of the extinguishers obvious?	.358	.830
Is there an automatic fire fighting system?	.358	.830

Result: We note from these results that the value of the alpha stability coefficient is 0.831 and the corrected item is between 0.212 and 0.835 and there is no value less than 0.19. Therefore, the previous correlation coefficients are acceptable internal stability coefficients.

3-8 Analysis and discussion:

The buildings were divided into two categories:

Group (I): Those which have safety and security systems applied in.

Group (II): Those which don't have safety and security systems applied in or not all of them.

The results were as follows:

Section One:

Table (3- 3): Function of the building

Source: Researcher

		Residential	Commercial	Industrial	Health care	Investment	Other	TOTAL
GROUP(I)	Frequency	3	7	3	2	3	7	25
	Percent	12	28	12	8	12	28	100
GROUP(II)	Frequency	7	4	1	1	5	7	25
	Percent	28	16	4	4	20	28	100

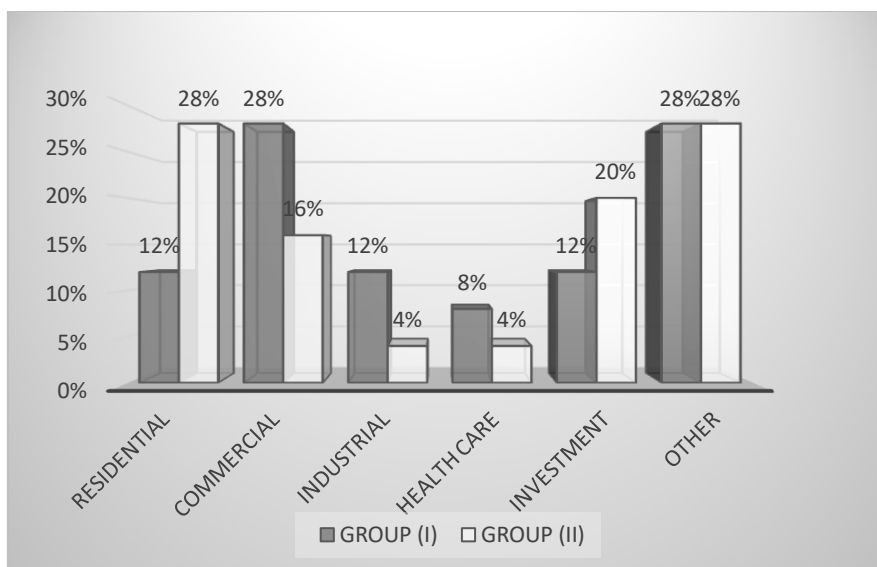

Figure (3- 1): Function of the building

Source: Researcher

Result: Function of buildings varied for the two groups (I, II) as follows: residential (12%, 28%), commercial (28%, 16%), industrial (12%, 4%), healthcare (8%, 4%), investments (12%, 20%) and other functions (28%, 28%).

Table (3- 4): Age of the building

Source: Researcher

		0-1	1-10	11-20	31+	TOTAL
GROUP(I)	Frequency	4	14	6	1	25
	Percent	16	56	24	4	100
GROUP(II)	Frequency	6	15	3	1	25
	Percent	24	60	12	4	100

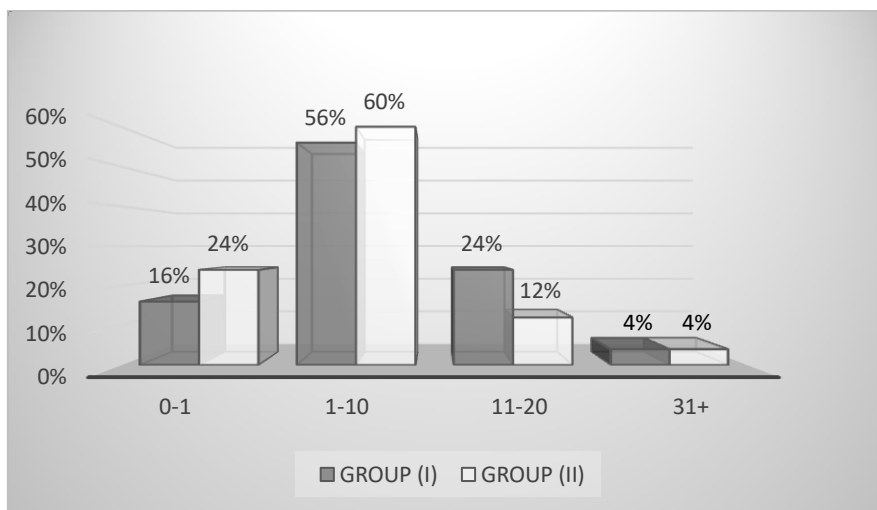

Figure (3- 2): Age of the building

Source: Researcher

Result: Age of building varied for the two groups (I, II) as follows: 0-1 (16%, 24%), 1-10 (56%, 60%), 11-20 (24%, 12%), +31 (4%, 4%).

Table (3- 5): Number of building users

Source: Researcher

		1-10	11-50	51-100	101-150	TOTAL
GROUP(I)	Frequency	7	6	7	5	25
	Percent	28	24	28	20	100
GROUP(II)	Frequency	8	8	6	3	25
	Percent	32	32	24	12	100

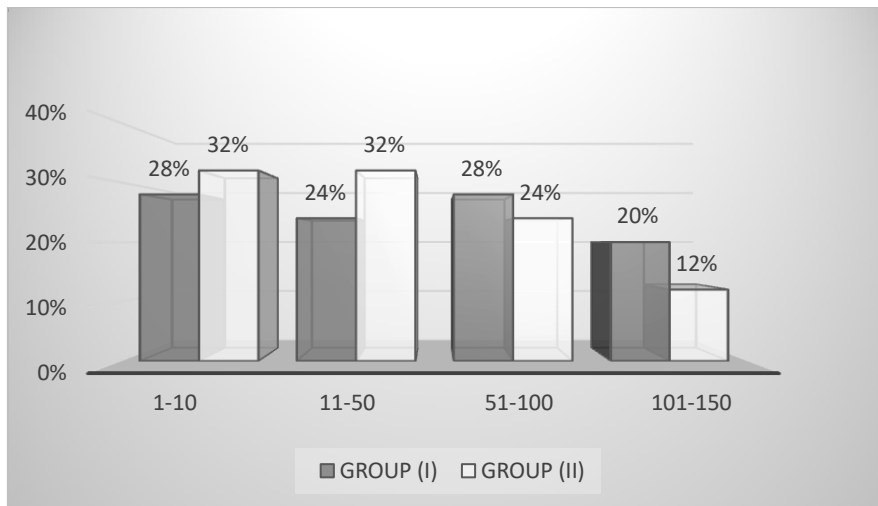

Figure (3- 3): Number of building users

Source: Researcher

Result: Number of building users varied for the two groups (I, II) as follows: 1-10 (28%, 32%), 11-50 (24%, 32%), 51-100 (28%, 24%), 101-150 (20%, 12%).

Table (3- 6): Number of floors

Source: Researcher

		1-3	4-6	7-10	+11	TOTAL
GROUP(I)	Frequency	12	8	3	2	25
	Percent	48	32	12	8	100
GROUP(II)	Frequency	10	10	2	3	25
	Percent	40	40	8	12	100

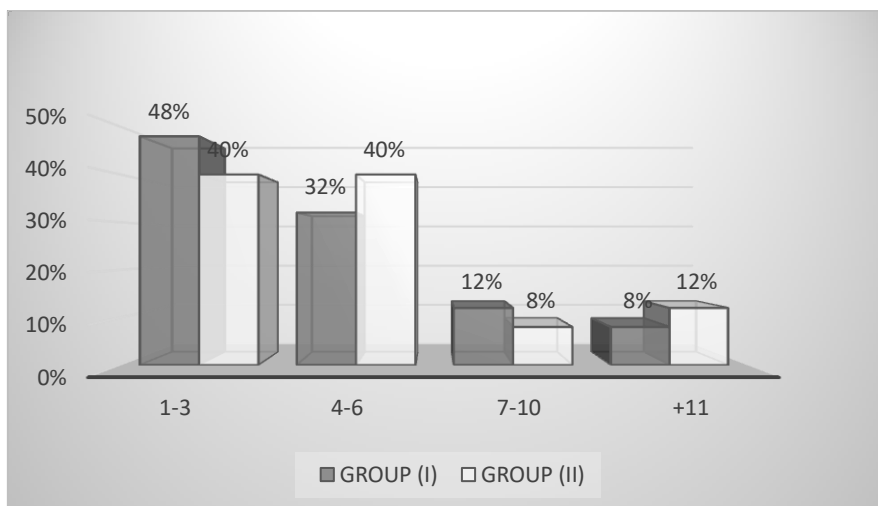

Figure (3- 4): Number of floors

Source: Researcher

Result: Number of floors varied for the two groups (I, II) as follows: 1-3 (48%, 40%), 4-6 (32%, 40%), 7-10 (12%, 8%), +11 (8%, 12%).

Table (3- 7): Material of building structure

Source: Researcher

		Steel	Concrete	Steel & Concrete	Other	Don't Know	TOTAL
GROUP(I)	Frequency	1	20	1	1	2	25
	Percent	4	80	4	4	8	100
GROUP(II)	Frequency	2	15	3	5	0	25
	Percent	8	60	12	20	0	100

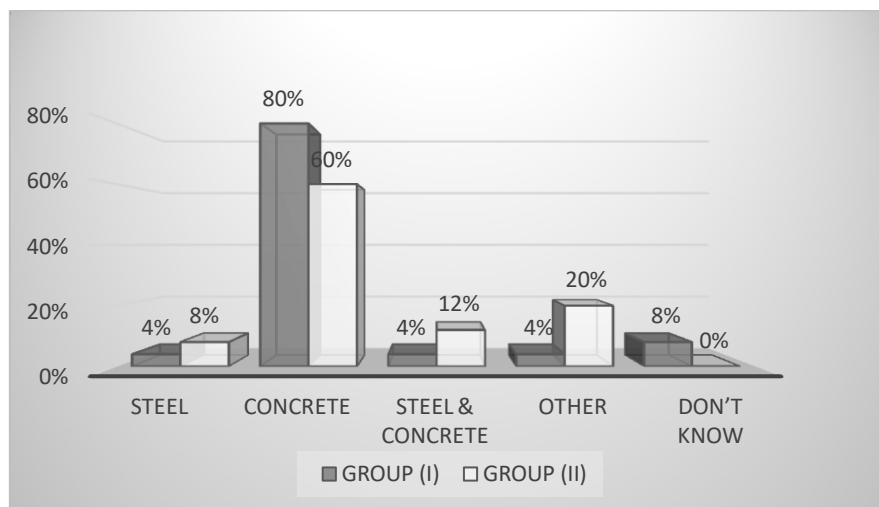

Figure (3- 5): Material of building structure

Source: Researcher

Result: Material building structure varied for the two groups (I, II) as follows: steel (4%, 8%), concrete (80%, 60%), steel & concrete (4%, 12%), other (4%, 20%), don't know (8%, 0%).

Table (3- 8): Material of building finishing

Source: Researcher

		Brick	Cement	Glass	Metal	Several	Other	TOTAL
GROUP(I)	Frequency	4	3	2	1	13	2	25
	Percent	16	12	8	4	52	8	100
GROUP(II)	Frequency	5	3	1	1	12	3	25
	Percent	20	12	4	4	48	12	100

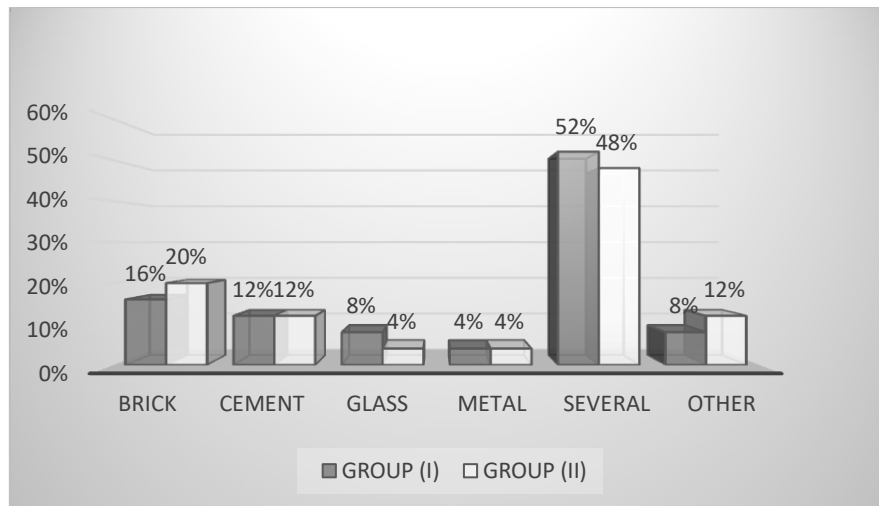

Figure (3- 6): Material of building finishing

Source: Researcher

Result: Material of building finishing varied for the two groups (I, II) as follows: brick (16%, 20%), cement (12%, 12%), glass (8%, 4%), metal (4%, 4%), several (52%, 48%), other (8%, 12%).

Section Two:

Table (3- 9): Have you been in trouble to access the building?

Source: Researcher

		YES	NO	TOTAL
GROUP(I)	Frequency	16	9	25
	Percent	64	36	100
GROUP(II)	Frequency	1	24	25
	Percent	4	96	100

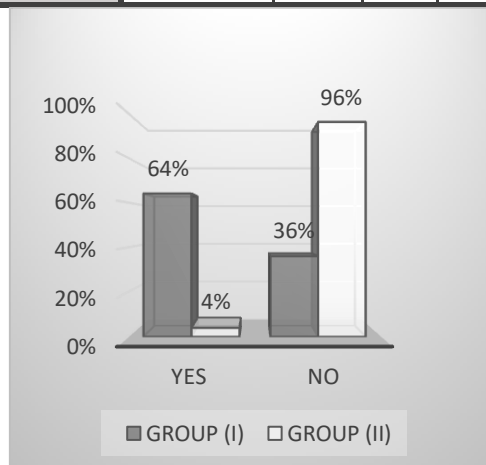

Figure (3- 7): Have you been in trouble to access the building?

Source: Researcher

Result: Those who have you been in trouble to access the building for the two groups (I, II) as follows: (64%, %4).

Table (3- 10): Have you been roped in the building before?

Source: Researcher

		YES	NO	TOTAL
GROUP(I)	Frequency	5	20	25
	Percent	20	80	100
GROUP(II)	Frequency	15	10	25
	Percent	60	40	100

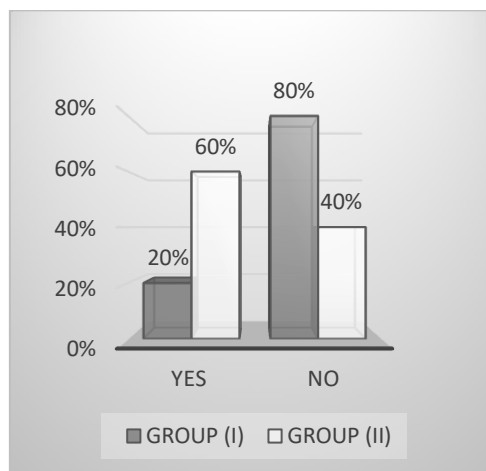

Figure (3- 8): Have you been roped in the building before?

Source: Researcher

Result: Those who have you been roped in the building before for the two groups (I, II) as follows: (20%, %60).

Table (3- 11): Do you have a backup power supply?

Source: Researcher

		YES	NO	TOTAL
GROUP(I)	Frequency	19	6	25
	Percent	76	24	100
GROUP(II)	Frequency	9	16	25
	Percent	36	64	100

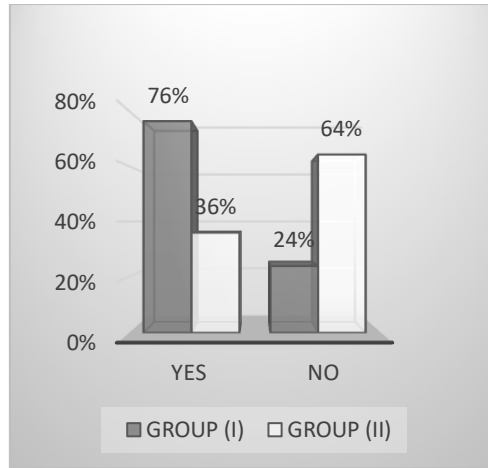

Figure (3- 9): Do you have a backup power supply?

Source: Researcher

Result: Those who have a backup power supply for the two groups (I, II) as follows: (76%, %36).

Table (3- 12): Do you have an emergency plan?

Source: Researcher

		YES	NO	TOTAL
GROUP(I)	Frequency	19	6	25
	Percent	76	24	100
GROUP(II)	Frequency	7	18	25
	Percent	28	72	100

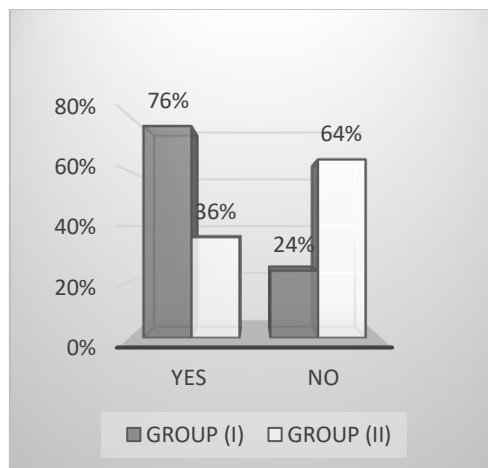

Figure (3- 10): Do you have an emergency plan?

Source: Researcher

Result: Those who have an emergency plan for the two groups (I, II) as follows: (76%, %36).

Section Three:

Table (3- 13): Do you have access control system?

Source: Researcher

		YES	NO	TOTAL
GROUP(I)	Frequency	20	5	25
	Percent	80	20	100
GROUP(II)	Frequency	9	16	25
	Percent	36	64	100

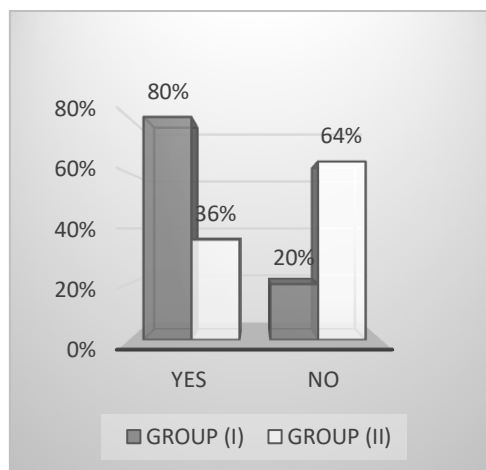

Figure (3- 11): Do you have access control system?

Source: Researcher

Result: Those who have access control system in the building for the two groups (I, II) as follows: (80%, %36).

Table (3- 14): What type of Access system?

Source: Researcher

		Human Guards	Magnetic cards	Finger print	Face/ voice/ eye scan	Other	TOTAL
GROUP(I)	Frequency	3	11	3	1	2	20
	Percent	15	55	15	5	10	100
GROUP(II)	Frequency	7	2	0	0	0	9
	Percent	77.7	22.3	0	0	0	100

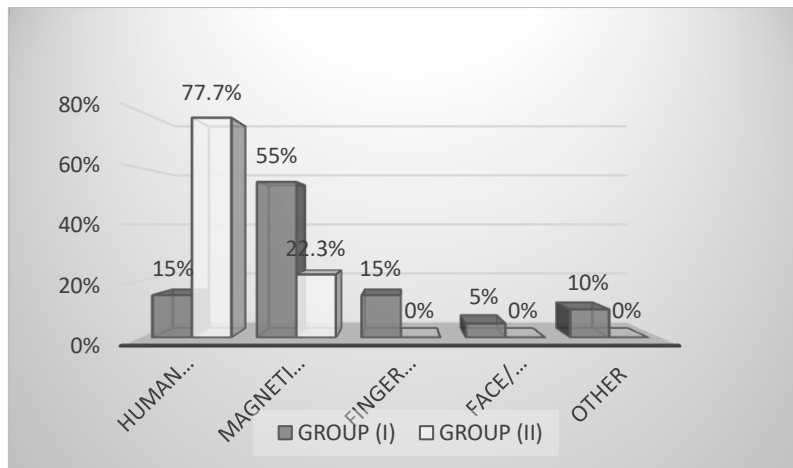

Figure (3- 12): What type of Access system?

Source: Researcher

Result: The type of access control system in the building for the two groups (I, II) as follows: human (15%, 77.7%), magnetic cards (55%, 22.3%), finger print (15%, 0%), face/voice/eye scan (5%, 0%), other (10%, 0%).

Table (3- 15): How many doors are controlled? (Internal)

Source: Researcher

		1-2	3-4	5-6	7-10	16+	TOTAL
GROUP(I)	Frequency	10	2	5	2	1	20
	Percent	50	10	25	10	5	100
GROUP(II)	Frequency	5	3	1	0	0	9
	Percent	55.6	33.3	11.1	0	0	100

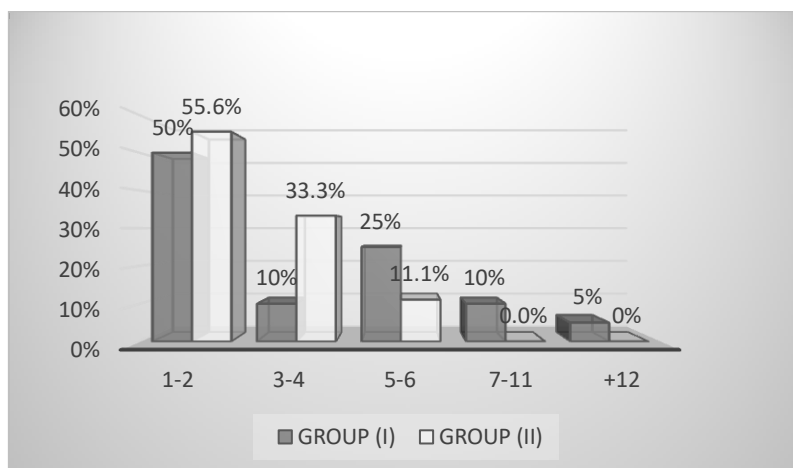

Figure (3- 13): How many doors are controlled? (Internal)

Source: Researcher

Result: Number of internal doors controlled for the two groups (I, II) as follows: 1-2 (50%, 55.6%), 3-4 (10%, 33.3%), 5-6 (25%, 11.1%), 7-11 (10%, 0%), +12 (5%, 0%).

Table (3- 16): How many doors are controlled? (External)

Source: Researcher

		1-2	3-4	5-6	7-10	16+	TOTAL
GROUP(I)	Frequency	9	4	3	2	2	20
	Percent	45	20	15	10	10	100
GROUP(II)	Frequency	5	1	1	1	1	9
	Percent	55.6	11.1	11.1	11.1	11.1	100

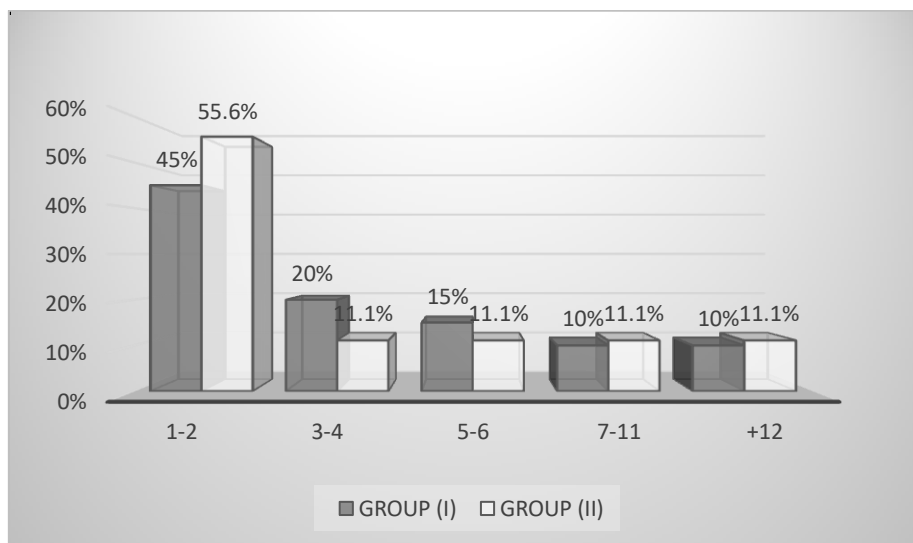

Figure (3- 14): How many doors are controlled? (External)

Source: Researcher

Result: Number of external doors controlled for the two groups (I, II) as follows: 1-2 (45%, 55.6%), 3-4 (20%, 11.1%), 5-6 (15%, 11.1%), 7-11 (10%, 11.1%), +12 (10%, 11.1%).

Table (3- 17): Does the system integrate with CCTV?

Source: Researcher

		YES	NO	TOTAL
GROUP(I)	Frequency	14	6	20
	Percent	70	30	100
GROUP(II)	Frequency	3	6	9
	Percent	33.3	66.7	100

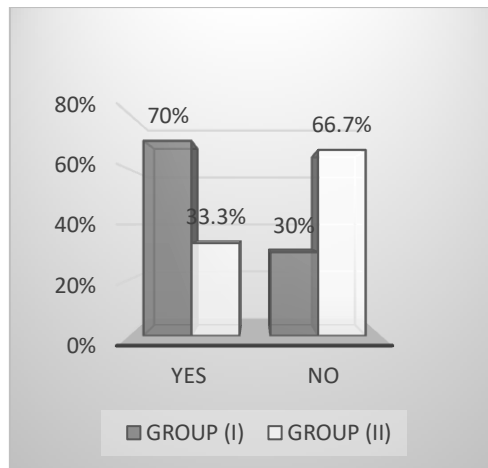

Figure (3- 15): Does the system integrate with CCTV?

Source: Researcher

Result: Those who have access control system integrated with CCTV system in the building for the two groups (I, II) as follows: (70%, 33.3%).

Section Four:

Table (3- 18): Do you have CCTV system in the building?

Source: Researcher

		YES	NO	TOTAL
GROUP(I)	Frequency	20	5	25
	Percent	80	20	100
GROUP(II)	Frequency	4	21	25
	Percent	16	84	100

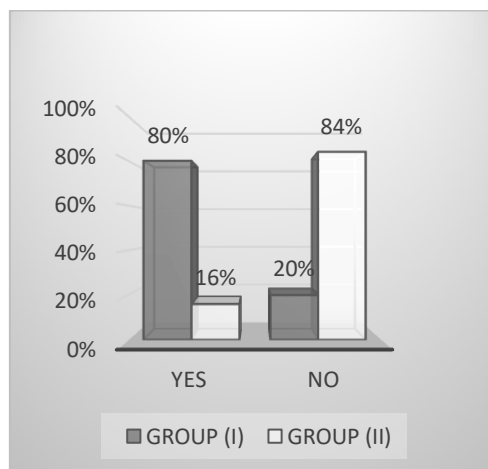

Figure (3- 16): Do you have CCTV system in the building?

Source: Researcher

Result: Those who have CCTV system in the building for the two groups (I, II) as follows: (80%, 16%).

Table (3- 19): If yes, where are the cameras applied?

Source: Researcher

		Indoor	Outdoor	Both in & out	TOTAL
GROUP(I)	Frequency	0	0	20	20
	Percent	0	0	100	100
GROUP(II)	Frequency	0	0	4	4
	Percent	0	0	100	100

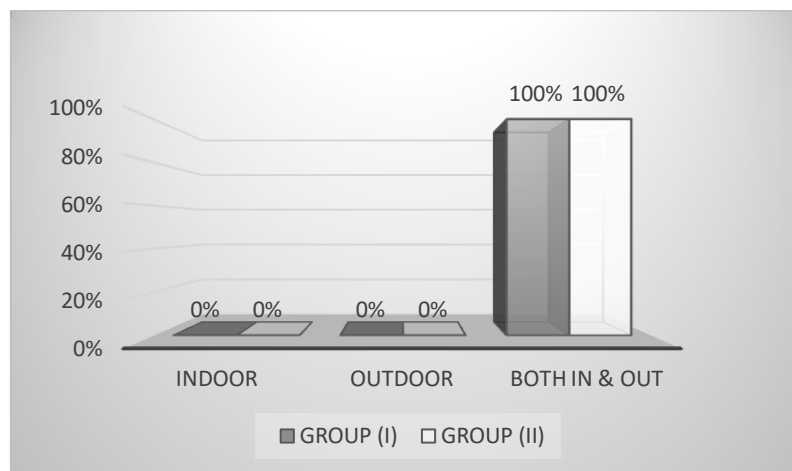

Figure (3- 17): If yes, where are the cameras applied?

Source: Researcher

Result: CCTV application in the building varied for the two groups (I, II) as follows: indoor (0%, 0%), outdoor (0%, 0%), both indoor & outdoor (100%, 100%).

Table (3- 20): Camera mounting

Source: Researcher

		Ceiling	Wall	Multiple	TOTAL
GROUP(I)	Frequency	5	2	13	20
	Percent	25	10	65	100
GROUP(II)	Frequency	1	1	2	4
	Percent	25	25	50	100

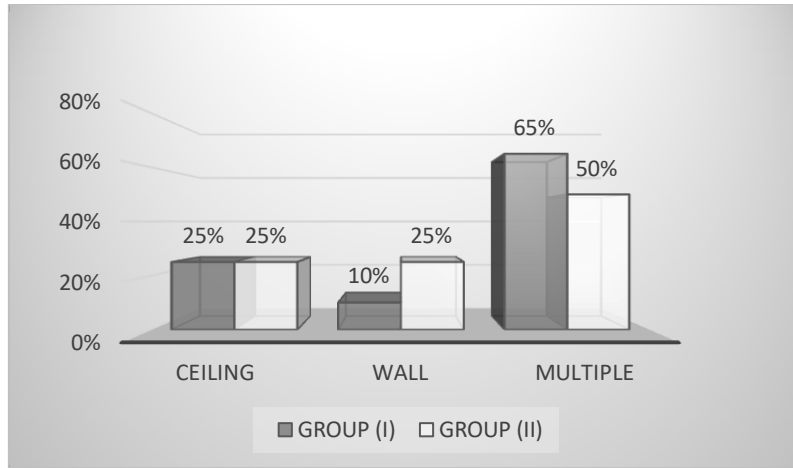

Figure (3- 18): Camera mounting

Source: Researcher

Result: CCTV mounting in the building varied for the two groups (I, II) as follows: ceiling (25%, 25%), wall (10%, 25%), multiple (65%, 50%).

Table (3- 21): Total number of cameras in the system (Internal)

Source: Researcher

		1-10	11-20	21-30	31-40	51-60	71+	TOTAL
GROUP(I)	Frequency	10	5	2	1	1	1	20
	Percent	50	25	10	5	5	5	100
GROUP(II)	Frequency	4	0	0	0	0	0	4
	Percent	100	0	0	0	0	0	100

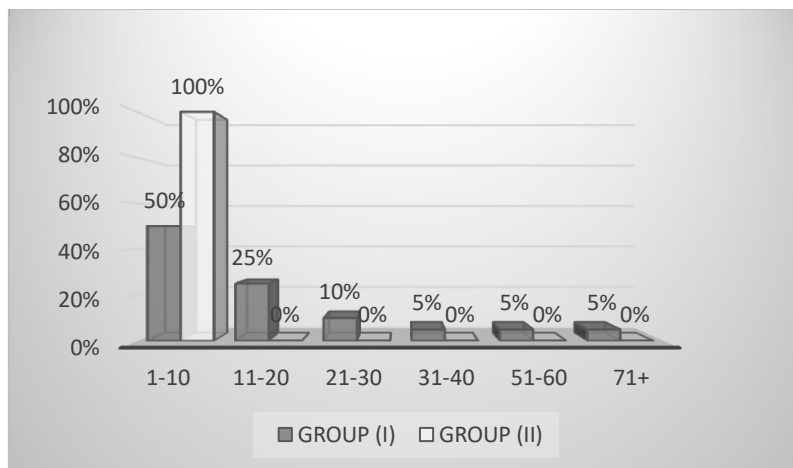

Figure (3- 19): Total number of cameras in the system (Internal)

Source: Researcher

Result: Internal CCTV numbers in the building varied for the two groups (I, II) as follows: 1-10 (50%, 100%), 11-20 (25%, 0%), 21-30 (10%, 0%), 31-40 (5%, 0%), 51-60 (5%, 0%), +71 (5%, 0%).

Table (3- 22): Total number of cameras in the system (External)

Source: Researcher

		1-10	11-20	21-30	31-40	51-60	71+	TOTAL
GROUP(I)	Frequency	14	2	1	1	1	1	20
	Percent	70	10	5	5	5	5	100
GROUP(II)	Frequency	4	0	0	0	0	0	25
	Percent	100	0	0	0	0	0	100

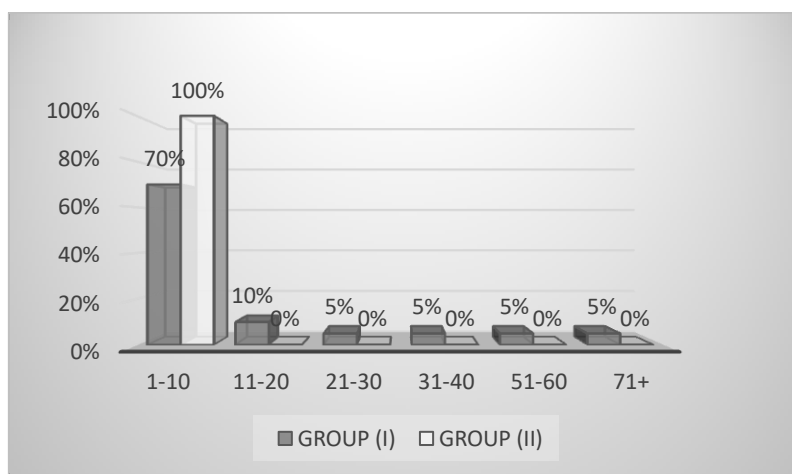

Figure (3- 20): Total number of cameras in the system (External)

Source: Researcher

Result: External CCTV numbers in the building varied for the two groups (I, II) as follows: 1-10 (70%, 100%), 11-20 (10%, 0%), 21-30 (5%, 0%), 31-40 (5%, 0%), 51-60 (5%, 0%), +71 (5%, 0%).

Section Five:

Table (3- 23): Have the building been on fire before?

Source: Researcher

		YES	NO	TOTAL
GROUP(I)	Frequency	4	21	25
	Percent	16	84	100
GROUP(II)	Frequency	13	12	25
	Percent	52	48	100

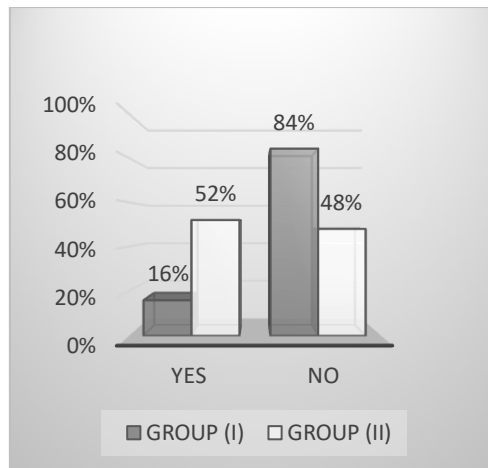

Figure (3- 21): Have the building been on fire before?

Source: Researcher

Result: Those who had fire in the building for the two groups (I, II) as follows: (16%, 52%).

Table (3- 24): If yes, what is the cause of the fire?

Source: Researcher

		Electrical	Smoking	Other	TOTAL
GROUP(I)	Frequency	4	0	0	4
	Percent	100	0	0	100
GROUP(II)	Frequency	8	5	0	13
	Percent	61.5	38.5	0	100

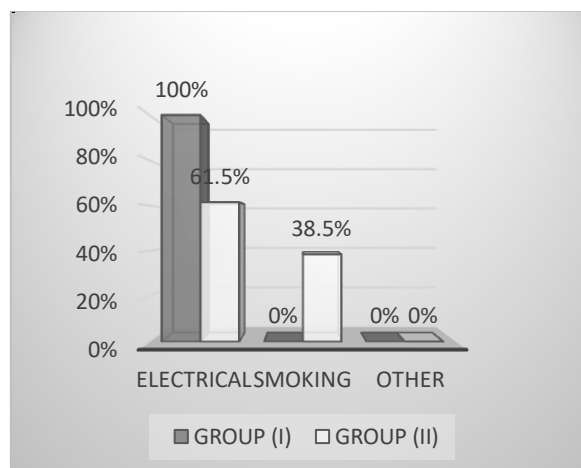

Figure (3- 22): If yes, what is the cause of the fire?

Source: Researcher

Result: Cause of the fire in the building varied for the two groups (I, II) as follows: electrical (100%, 61.5%), smoking (0%, 38.5%), other (0%, 0%).

Table (3- 25): Is there a designated smoking area provided with adequate ashtrays?

Source: Researcher

		YES	NO	TOTAL
GROUP(I)	Frequency	15	10	25
	Percent	60	40	100
GROUP(II)	Frequency	6	19	25
	Percent	24	76	100

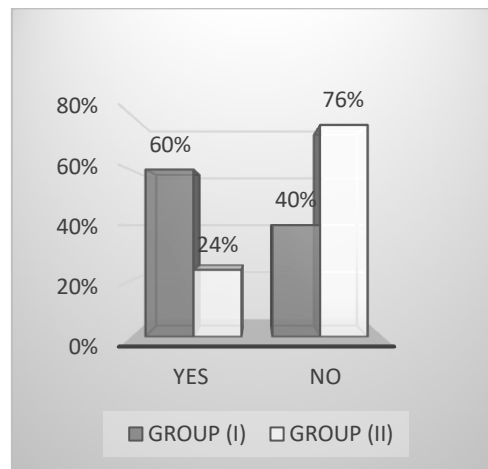

Figure (3- 23): Is there a designated smoking area provided with adequate ashtrays?

Source: Researcher

Result: Those who have designed area for smoking in the building for the two groups (I, II) as follows: (60%, 24%).

Table (3- 26): Are there any means of fire detectors?

Source: Researcher

		YES	NO	TOTAL
GROUP(I)	Frequency	19	6	25
	Percent	76	24	100
GROUP(II)	Frequency	7	18	25
	Percent	28	72	100

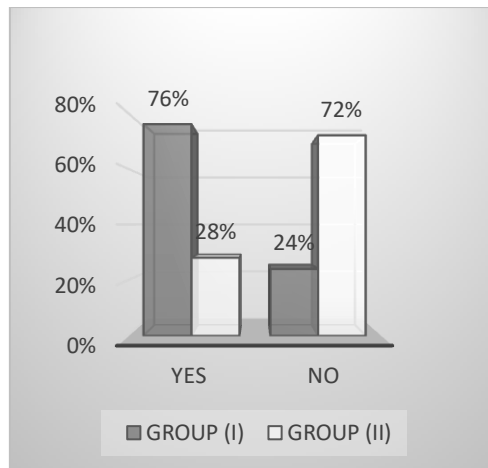

Figure (3- 24): Are there any means of fire detectors?

Source: Researcher

Result: Those who have means of fire detectors in the building for the two groups (I, II) as follows: (76%, 28%).

Table (3- 27): are there any means of emergency alarms?

Source: Researcher

		YES	NO	TOTAL
GROUP(I)	Frequency	19	6	25
	Percent	76	24	100
GROUP(II)	Frequency	7	18	25
	Percent	28	72	100

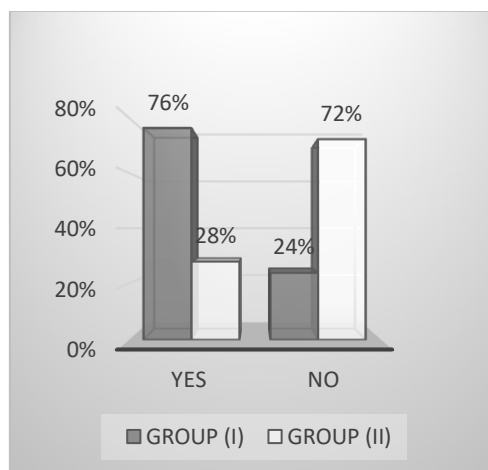

Figure (3- 25): are there any means of emergency alarms?

Source: Researcher

Result: Those who have means of emergency alarms in the building for the two groups (I, II) as follows: (76%, 28%).

Table (3- 28): Are there fire extinguishers?

Source: Researcher

		YES	NO	TOTAL
GROUP(I)	Frequency	19	6	25
	Percent	76	24	100
GROUP(II)	Frequency	7	18	25
	Percent	28	72	100

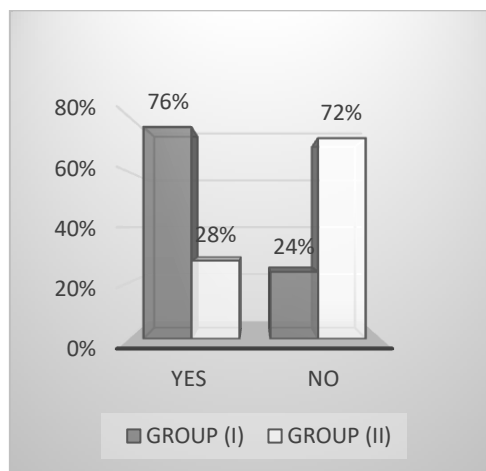

Figure (3- 26): Are there fire extinguishers?

Source: Researcher

Result: Those who have fire extinguishers in the building for the two groups (I, II) as follows: (76%, 28%).

Table (3- 29): Is there an automatic fire fighting system?

Source: Researcher

		YES	NO	TOTAL
GROUP(I)	Frequency	19	6	25
	Percent	76	24	100
GROUP(II)	Frequency	7	18	25
	Percent	28	72	100

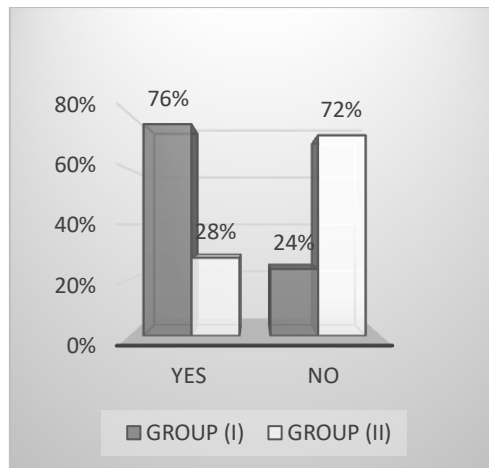

Figure (3- 27): Is there an automatic fire fighting system?

Source: Researcher

Result: Those who have automatic firefighting system in the building for the two groups (I, II) as follows: (76%, 28%).

CHAPTER FOUR: CONCLUSION AND RECOMMENDATIONS

4-1 Introduction

This section contains a summary of the results of the study, questions are grouped in order to answer the questions of the study: What are the main dangers that threaten the occupants and the reasons that they occur? Are the safety and security systems applied in buildings according to the standards? Are the safety and security systems working efficiently?

4-2 Results

What are the main dangers that threaten the occupants and the reasons that they occur?

Table (4- 1): Results summary - General dangers

Source: Researcher

		Have you been roped in the building before?	Have you been in trouble to access the building?	Have the building been on fire before?
GROUP(I)	Yes	20	64	16
GROUP(II)	Yes	60	4	52
		Electrical	Smoking	Other
GROUP(I)	Percent	100	0	0
GROUP(II)	Percent	61.5	38.5	0

Result:

1. Those who have been roped in the building before for the two groups (I, II) as follows: (20%, %60).
2. Those who have you been in trouble to access the building for the two groups (I, II) as follows: (64%, %4).
3. Those who had fire in the building for the two groups (I, II) as follows: (16%, 52%).

4. Cause of the fire in the building varied for the two groups (I, II) as follows: electrical (100%, 61.5%), smoking (0%, 38.5%), other (0%, 0%).

Are the safety and security systems applied in buildings according to the standards? And working efficiently?

Table (4- 2): Results summary - Access Control System

Source: Researcher

Access control system						
		Do you have access control system?		Does the system integrate with CCTV?		
GROUP(I)	Yes	80		70		
GROUP(II)	Yes	36		33.3		
Type of access control						
		Human Guards	Magnetic cards	Finger print	Face/ voice/ eye scan	Other
GROUP(I)	Percent	15	55	15	5	10
GROUP(II)	Percent	77.7	22.3	0	0	0
Doors controlled						
		1-2	3-4	5-6	7-10	16+
GROUP(I)	Internal	50	10	25	10	5
	External	45	20	15	10	10
GROUP(II)	Internal	55.6	33.3	11.1	0	0
	External	55.6	11.1	11.1	11.1	11.1

Result:

1. Those who have access control system in the building for the two groups (I, II) as follows: (80%, %36).
2. Those who have access control system integrated with CCTV system in the building for the two groups (I, II) as follows: (70%, 33.3%).
3. The type of access control system in the building for the two groups (I, II) as follows: human (15%, 77.7%), magnetic cards (55%, 22.3%), finger print (15%, 0%), face/voice/eye scan (5%, 0%), other (10%, 0%).

4. Number of internal doors controlled for the two groups (I, II) as follows:
1-2 (50%, 55.6%), 3-4 (10%, 33.3%), 5-6 (25%, 11.1%), 7-11 (10%, 0%),
+12 (5%, 0%).
5. Number of external doors controlled for the two groups (I, II) as follows:
1-2 (45%, 55.6%), 3-4 (20%, 11.1%), 5-6 (15%, 11.1%), 7-11 (10%,
11.1%), +12 (10%, 11.1%).

Table (4- 3): Results summary - CCTV System

Source: Researcher

CCTV system							
		Have you been roped in the building before?	Do you have CCTV system in the building?	Do you have access control system integrated to CCTV system?	Does the system integrate with CCTV?		
GROUP(I)	Yes		80	70			
GROUP(II)	Yes		16	33.3			
Cameras Location							
		Indoor		Outdoor		Both in & out	
	Percent	0		0		100	
	Percent	0		0		100	
Cameras mounting							
		Ceiling	Wall	Multiple	TOTAL		
	Percent	25	10	65	100		
	Percent	25	25	50	100		
Number of cameras in the system							
		1-10	11-20	21-30	31-40	51-60	71+
GROUP(I)	Internal	50	25	10	5	5	5
	External	70	10	5	5	5	5
GROUP	Internal	100	0	0	0	0	0
	External	100	0	0	0	0	0

Result:

1. CCTV application in the building varied for the two groups (I, II) as follows: indoor (0%, 0%), outdoor (0%, 0%), both indoor & outdoor (100%, 100%).
2. CCTV system mounting in the building varied for the two groups (I, II) as follows: ceiling (25%, 25%), wall (10%, 25%), multiple (65%, 50%).

3. Internal CCTV cameras numbers in the building varied for the two groups (I, II) as follows: 1-10 (50%, 100%), 11-20 (25%, 0%), 21-30 (10%, 0%), 31-40 (5%, 0%), 51-60 (5%, 0%), +71 (5%, 0%).
4. External CCTV cameras numbers in the building varied for the two groups (I, II) as follows: 1-10 (70%, 100%), 11-20 (10%, 0%), 21 -30 (5%, 0%), 31 -40 (5%, 0%), 51 -60 (5%, 0%), +71 (5%, 0%).

Table (4- 4): Results summary - Firefighting System

Source: Researcher

Firefighting system									
		Have the building been on fire before?	Is there a designated smoking area provided with adequate ashtrays?	Are there any means of fire detectors?	are there any means of emergency alarms?	Are there fire extinguishers?	Is there an automatic fire fighting system?	Do you have an emergency plan?	Do you have a backup power supply?
GROUP(I)	Yes	16	60	76	76	76	76	76	76
GROUP(II)	Yes	52	24	28	28	28	28	36	36

Result:

1. Those who had fire in the building for the two groups (I, II) as follows: (16%, 52%).
2. Those who have designed area for smoking in the building for the two groups (I, II) as follows: (60%, 24%).
3. Those who have means of fire detectors in the building for the two groups (I, II) as follows: (76%, 28%).
4. Those who have means of emergency alarms in the building for the two groups (I, II) as follows: (76%, 28%).
5. Those who have fire extinguishers in the building for the two groups (I, II) as follows: (76%, 28%).
6. Those who have automatic firefighting system in the building for the two groups (I, II) as follows: (76%, 28%).
7. Those who have a backup power supply for the two groups (I, II) as follows: (76%, %36).
8. Those who have an emergency plan for the two groups (I, II) as follows: (76%, %36).

4-3 Recommendations

Extracted from the results of the analysis of the data:

1. To deploy security and safety systems in all buildings and facilities
2. Development of existing security and safety systems
3. To sensitize users to the importance of security and protection systems
4. Work to link systems together to operate more efficiently and effectively
5. The importance of linking the systems to the nearest police station and fire brigade
6. Distribution of surveillance cameras to cover all parts of the building or at least important places
7. Attention to the drawings and the implementation of electrical work
8. Ensure that all internal and external building entrances are controlled
9. Provide smoking places in buildings and prevent smoking in public places
10. Make sure there is an emergency plan
11. Make sure there is a backup generator for the building

4-4 Suggested topics

1. Access Control: Types & Implementation
2. The access control management
3. Importance of building access control
4. Closed-circuit television camera types and implementation
5. Importance of building CCTV system
6. Evaluating the Effectiveness of CCTV in buildings
7. A Study on Improving the Location of CCTV system

BIBLIOGRAPHY:

ENGLISH REFERENCES:

1. CCTV student's handbook, Kristina Irelan and John Ehlers, 2005.
2. Handbook on Building Fire Codes, G.B. Menon Fire Adviser, 2005.
3. CCTV Technology Handbook, Space and Naval Warfare Systems Center Atlantic, 2013.
4. Perimeter Security Sensor Technology hand book , Mr. J.A. Koenig and Mr. L. Taylor, 1997.
5. Security Systems, North Charleston, 2011.
6. Oriented Software Architecture, Wiley, 1996.
7. Code of Practices for Fire Precautions in Buildings, 2007.
8. Singapore Standard Code of Practice for Scaffolds, 1996.
9. University of Maryland Fire and Life Safety Guide, 2012.
10. SOLAS, IMO, 2014.
11. FSS CODE, IMO, 2007.
12. Inert Gas Systems, IMO, 1990.
13. Fire Training Manual– I.C BRINDLE & COISGOTT, 2011.

PAPERS AND RESEARCHES:

14. A simple and reliable touch sensitive security system, Adamu Murtala Zungeru1, 2014.
15. Application notes – access control, Yorkland controls, 2007.
16. Kentucky Revised Statutes, 2015.

GOVERNMENT DOCUMENTS:

17. Sudan Civil Defense Administration (2003).
18. Home Security, Crime and violence prevention center, California,2000.

MAGAZINES:

19. International Journal of Advanced Research in Electrical, Electronics and Instrumentation, 2013.

ELECTRONIC WEBSITES:

20. "False alarm", <http://www.alarm.org/false/tips/dealer tip/dealer tip.html>
21. <http://www.icee.org/organization/history center/fire alarm.html>
22. www.master.postgraduatestudy.eu

CHAPTER FIVE: APPENDICES

Questionnaire

Purpose

This questionnaire aims to collect information on the application of safety and security systems in buildings at Khartoum in order to complete the research for a master's degree in Building Services Department. Completing this questionnaire is voluntary, but your assistance would be greatly appreciated to help improve the safety and security of the building occupants.

SECTION 1: Please provide background information about you.

1. **Are you:** Male Female
2. **What is your age?** 18-25 26-35 36-45 46-55 56-65
 66+
3. **What is the highest level of formal education you have completed?**
(Please check only one.) High school BA Postgraduate Diploma
4. **What is your marital status?**
 Currently married Widowed Divorced Separated Never married
5. **What is your specialization?**
 Architect Civil Engineer Electronic Engineer Software Engineer
 Mechanical Engineer Other

SECTION 6: About the Building Questions

1. **Function of the building:** Residential Commercial Industrial Health care Other
2. **Age of the building:** 0-1 1-10 years 11-20 years 21-30 31+
3. **Number of users:** 1-10 11-50 51-100 101-150
4. **Number of floors:** 1-3 4-6 7-10 11+
5. **Material of building structure:** Steel Concrete Steel & Concrete other Don't know
6. **Material of building structure:** Brick Cement Glass Metal Several Other

SECTION 2: General Safety and Security Questions

1. **Have you been in trouble to access the building?** Yes No

2. Have you been roped in the building before? Yes No
3. Do you have a backup power supply? Yes No
4. Do you have an emergency plan? Yes No

SECTION 3: Access Control System Questions

1. Do you have access control system? Yes No
 What type? Human Guards Magnetic cards Finger print
 Face/ voice/ eye scan Other

2. How many doors are controlled?

- Interior 1-2 3-4 5-6 7-10 11-15 16+
 -Exterior 1-2 3-4 5-6 7-10 11-15 16+

3. Does the system integrate with CCTV? Yes No

SECTION 4: CCTV system Questions

1. Do you have CCTV System? Yes No
2. CCTV System application: indoors only outdoors only both
 indoors and outdoors
3. Total number of cameras in the system? 1-10 11-20 31-40
 51-60 71+
4. Camera mounting: ceiling wall multiple

SECTION 5: Firefighting Questions

1. Have the building been on fire before? Yes No
2. What is the cause of the fire? electrical gas smoking children
 play other
3. Is there a designated smoking area provided with adequate ashtrays?
 Yes No
4. Are there any means of fire detectors? Yes No
5. Are there any means of emergency alarms? Yes No
6. Are there fire extinguishers? Yes No
7. Is there an automatic fire fighting system? Yes No

Thank you for your time