

Chapter 1

Introduction and Basic concept

1.1 Introduction

Engineering is concerned with understanding and controlling the materials and forces of nature for the benefit of humankind. Control system engineers are concerned with understanding and controlling segments of their environment, often called systems, to provide useful economic products for society. The twin goals of understanding and controlling are complementary because effective systems control requires that the systems be understood and modeled. Furthermore, control engineering must often consider the control of poorly understood systems such as chemical process systems. The present challenge to control engineers is the modeling and control of modern, complex, interrelated systems such as traffic control systems, chemical processes, and robotic systems. Simultaneously, the fortunate engineer has the opportunity to control many useful and interesting industrial automation systems. Perhaps the most characteristic quality of control engineering is the opportunity to control machines and industrial and economic processes for the benefit of society. Control engineering is based on the foundations of feedback theory and linear system analysis, and it integrates the concepts of network theory and communication theory. Therefore control engineering is not limited to any engineering discipline but is equally applicable to aeronautical, chemical, mechanical, environmental, civil, and electrical engineering. For example, a control system often includes electrical, mechanical, and chemical components. Furthermore, as the understanding of the dynamics of business, social and political systems increases, the ability to control these systems will also increase. Control system is an interconnection of components forming a system configuration that will provide a desired system response. The basis for analysis of a system is the foundation provided by linear system theory, which assumes a cause-effect relationship for the components of a system. Therefore a component or process to be controlled can be represented by a block, as shown in Figure 1.1



Figure 1.1 Process to be controlled

The input-output relationship represents the cause-and-effect relationship of the process, which in turn represents a processing of the input signal to provide an output signal variable, often with power amplification. The PID controller is the most common form of feedback. It was an essential element of early governors and it became the standard tool when process control emerged in the 1940s. In process control today, more than 95% of the control loops are of PID type, most loops are actually PI control. PID controllers are today found in all areas where control is used. The controllers come in many different forms. There are standalone systems in boxes for one or a few loops, which are manufactured by the hundred thousand yearly. PID control is an important ingredient of a distributed control system. The controllers are also embedded in many special purpose control systems. PID control is often combined with logic, sequential functions, selectors, and simple function blocks to build the complicated automation systems used for energy production, transportation, and manufacturing. Many sophisticated control strategies, such as model predictive control, are also organized hierarchically. PID control is used at the lowest level; the multivariable controller gives the set points to the controllers at the lower level. It is an important Component in every control engineer's tool box. PID controllers have survived many changes in technology, from mechanics and pneumatics to microprocessors via electronic tubes, transistors, Integrated circuits. The microprocessor has had a dramatic influence on the PID controller. Practically all PID controllers made today are based on microprocessors. This has given opportunities to provide additional features like automatic tuning, gain scheduling, and continuous adaptation. PID controller is a common instrument used in industrial control applications. It can be used for regulation of speed, temperature, flow, pressure and other process variables.

1.2 A brief History of Systems and Control

Control theory has two main roots: regulation and trajectory optimization. The first, regulation, is the more important and engineering oriented one. The second, trajectory optimization, is mathematics based. However, as we shall see, these roots have to a large extent merged in the second half of the twentieth century. The problem of regulation is to design mechanisms that keep certain to-be controlled variables at constant values against external disturbances that act on the plant that is being regulated, or changes in its properties. The system that is being controlled is usually referred to as the plant, a passé partout term that can mean a physical or a chemical system. It could also be an economic or a biological system, but one would not use the engineering term “plant” in that case. Houses are regulated by thermostats so that the inside temperature remains constant, notwithstanding variations in the outside weather conditions or changes in the situation in the house: doors that may be open or closed the x Preface number of persons present in a room, activity in the kitchen, etc. Motors in washing machines, in dryers, and in many other household appliances are controlled to run at a fixed speed, independent of the load. Modern automobiles have dozens of devices that regulate various variables. It is, in fact, possible to view also the suspension of an automobile as a regulatory device that absorbs the irregularities of the road so as to improve the comfort and safety of the passengers. Regulation is indeed a very important aspect of modern technology. For many reasons, such as efficiency, quality control, safety, and reliability, industrial production processes require regulation in order to guarantee that certain key variables (temperatures, mixtures, pressures, etc) be kept at appropriate values. Factors that inhibit these desired values from being achieved are external disturbances, as for example the properties of raw materials and loading levels or changes in the properties of the plant, for example due to aging of the equipment or to failure of some devices. Regulation problems also occur in other areas, such as economics and biology. One of the central concepts in control is feedback, the value of one variable in the plant is measured and used (fed back)

in order to take appropriate action through a control variable at another point in the plant. A good example of a feedback regulator is a thermostat, it senses the room temperature, compares it with the set point (the desired temperature), and feeds back the result to the boiler, which then starts or shuts off depending on whether the temperature is too low or too high. Man has been devising control devices ever since the beginning of civilization, as can be expected from the prevalence of regulation problems. Control historians attribute the first conscious design of a regulatory feedback mechanism in the west to the Dutch inventor Cornelis Drebbel (1572–1633). Drebbel designed a clever contraption combining thermal and mechanical effects in order to keep the temperature of an oven at a constant temperature. Being an alchemist as well as an inventor, Drebbel believed that his oven, the A than or, would turn lead into gold. Needless to say, he did not meet with much success in this endeavor, notwithstanding the inventiveness of his temperature control mechanism. Later in the seventeenth century, Christian Huygens (1629–1695) invented a flywheel device for speed control of windmills. This idea was the basis of the centrifugal fly-ball governor used by James Watt (1736–1819), the inventor of the steam engine. The centrifugal governor regulated the speed of a steam engine. It was a very successful device used in all steam engines during the industrial revolution, and it became the first mass-produced control mechanism in existence. Many control laboratories have therefore taken Watt's fly-ball governor as their favorite icon. The control problem for steam engine speed occurred in a very natural way. During the nineteenth century, prime movers driven by steam engines were running throughout the grim.

Definition 1.1

Processes: The a process defines to be a natural, progressively continuing operation or development marked by a series of gradual changes that succeed one another in a relatively fixed way and lead toward a particular result or end; or an artificial or voluntary, progressively continuing operation that consists of a series of controlled actions or movements systematically directed toward a particular

result or end. We shall call any operation to be controlled a process. Examples are chemical, economic, and biological processes.

Definition 1.2

System: Is an interconnection of components forming a system configuration that will provide a desired system response. The basis for analysis of a system is the foundation provided by linear system, which assumes a cause effect relationship for the components of a system.

Definition 1.3

The controller: Is an element which accepts the error in some form and decides the proper corrective action. The output of the controller is then applied to the process or final control element. The controlled variable is the quantity or condition that is measured and controlled, the manipulated variable is the quantity or condition that is varied by the controller so as to affect the value of the controlled variable. Normally, the controlled variable is the output of the system.

Definition 1.4

A control system: Is a collection of components working together under the direction of some machine intelligence. This definition will show you the characteristics of each of proportional (P), the integral (I), and the derivative (D) controls, and how to use them to obtain a desired response. The concept of a control system is to sense deviation of output from the desired value and correct it, till the desired output is achieved. The deviation of the actual output from its desired value is called an error.

Definition 1.5

Control: means measuring the value of controlled variable of the system and applying the manipulated variable to the system to correct or limit deviation of the measured value from a desired value. The measurement of error is possible because of feedback. The feedback allows us to compare the actual output with its desired value to generate the error. The error is denoted as $e(t)$. The desired value

of the output is also called reference input or a set point .the error obtained is required to be analyses to take the proper corrective action.

Definition 1.6

Automatic Controllers: An automatic controller compares the actual value of the plant output with the reference input (desired value), determines the deviation, and produces a control signal that will reduce the deviation to zero or to a small value. The manner in which the automatic controller produces the control signal is called the control action. Figure is a block diagram of an industrial control

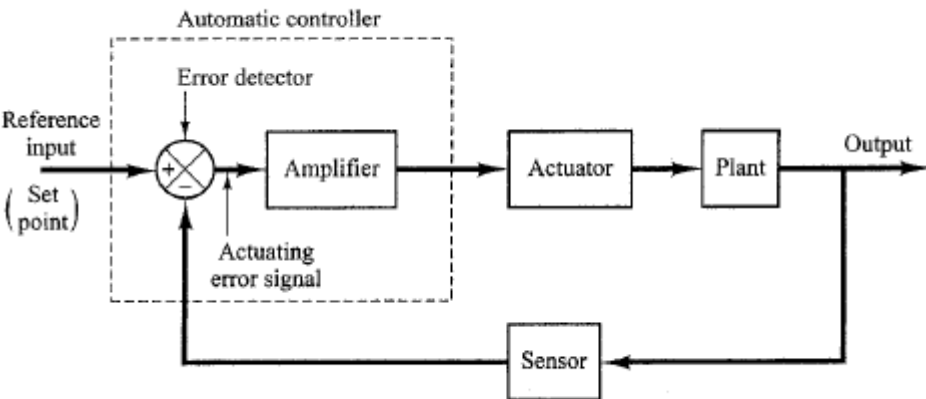

Figure1.2 Block diagram of an automatic controller

System which consists of an automatic controller an actuator a plant, and a sensor (measuring element). The controller detects the actuating error signal, which is usually at a very low power level, and amplifies it to a sufficiently high level. The output of an automatic controller is fed to an actuator, such as an electric motor, a hydraulic motor, or a -pneumatic motor or valve. (The actuator is a power device that produces the input to the plant according to the control signal so that the output signal will approach the reference input signal.)The sensor or measuring element is a device that converts the output variable into another suitable variable, such as a displacement, pressure, or voltage, that can be used to compare the output to the reference input signal. This element is in the feedback path of the closed-loop system. The set point of the controller must be converted to a reference input with the same units as the feedback signal from the sensor or measuring element.

1.3 Modern Control Theory Versus Conventional Control Theory

Modern control theory is contrasted with conventional control theory in that the former is applicable to multiple-input, multiple-output systems, which may be linear or nonlinear, time invariant or time varying, while the latter is applicable only to linear time invariant single-input, single-output systems. Also, modern control theory is essentially time-domain approach and frequency domain approach (in certain cases such as H-infinity control), while conventional control theory is a complex frequency-domain approach. Before we proceed further, we must define state, state variables, state vector, and state space

Definition 1.7

State: The state of a dynamic system is the smallest set of variables (called state variables) such that knowledge of these variables at $t = t_0$, together with knowledge of the input for $t \geq t_0$, completely determines the behavior of the system for any time $t \geq t_0$. Note that the concept of state is by no means limited to physical systems. It is applicable to biological systems, economic systems, social systems, and others.

Definition 1.8

State Variables: The state variables of a dynamic system are the variables making up the smallest set of variables that determine the state of the dynamic system. If a least n variables x_1, x_2, p, \dots, x_n are needed to completely describe the behavior of a dynamic system (so that once the input is given for $t \geq t_0$ and the initial state at $t = t_0$ is specified, the future state of the system is completely determined), then such n variables are a set of state variables. Note that state variables need not be physically measurable or observable quantities. Variables that do not represent physical quantities and those that are neither measurable nor observable can be chosen as state variables. Such freedom in choosing state variables is an advantage of the state-space methods. Practically, however, it is convenient to choose easily measurable quantities for the state variables, if this is possible at all, because optimal control laws will require the feedback of all state variables with suitable weighting.

Definition 1.9

State Vector: If n state variables are needed to completely describe the behavior of a given system, then these n state variables can be considered the n components of a vector \mathbf{x} . Such a vector is called a state vector. A state vector is thus a vector that determines uniquely the system state $\mathbf{x}(t)$ for any time $t \geq t_0$, once the state at $t = t_0$ is given and the input $u(t)$ for $t \geq t_0$ is specified.

Definition 1.10

State Space: The n -dimensional space whose coordinate axes consist of the x_1 axis, x_2 axis, p , x_n axis, where x_1, x_2, p, \dots, x_n are state variables, is called a state space. Any state can be represented by a point in the state space

Definition 1.11

State-Space Equations: In state-space analysis we are concerned with three types of variables that are involved in the modeling of dynamic systems: input variables, output variables, and state variables. The state-space representation for a given system is not unique, except that the number of state variables is the same for any of the different state-space representations of the same system. The dynamic system must involve elements that memorize the values of the input for $t > t_1$. Since integrators in a continuous-time control system serve as memory devices, the outputs of such integrators can be considered as the variables that define the internal state of the dynamic system. Thus the outputs of integrators serve as state variables. The number of state variables to completely define the dynamics of the system is equal to the number of integrators involved in the system. Assume that a multiple-input, multiple-output system involves n integrators. Assume also that there are r inputs $u_1(t), u_2(t), \dots, u_r(t)$ and m outputs $y_1(t), y_2(t), \dots, y_m(t)$. For such system the state variable representation can be arranged in the form of n first order differential equations

$$\dot{x}_1(t) = f_1(x_1, x_2, \dots, x_n; u_1, u_2, \dots, u_r; t) \quad (1.1)$$

$$\dot{x}_2(t) = f_2(x_1, x_2, \dots, x_n; u_1, u_2, \dots, u_r; t) \quad (1.2)$$

.

.

$$\dot{x}_n(t) = f_n(x_1, x_2, \dots, x_n; u_1, u_2, \dots, u_r; t)$$

The outputs $y_1(t), y_2(t), \dots, y_m(t)$ of the system may be given by

$$Y_1(t) = g_1(x_1, x_2, \dots, x_n; u_1, u_2, \dots, u_r; t)$$

$$Y_2(t) = g_2(x_1, x_2, \dots, x_n; u_1, u_2, \dots, u_r; t)$$

⋮

⋮

$$= y_1(t), y_2(t), \dots, y_m(t)$$

Then Equations (1.1) and (1.2) become

$$\dot{x}(t) = f(x, u, t) \tag{1.3}$$

$$y(t) = g(x, u, t) \tag{1.4}$$

Where Equation (1.3) is the state equation and Equation (1.4) is the output equation. If vector functions f and g involve time t explicitly, then the system is called a time varying system. If Equations (1.3) and (1.4) are linearized about the operating state, then we have the following linearized state equation and output equation:

$$\dot{x}(t) = Ax(t) + Bu(t) \tag{1.5}$$

$$y(t) = Cx(t) + Du(t) \tag{1.6}$$

Where $A(t)$ is called the state matrix $B(t)$ the input matrix $C(t)$ the output matrix, and $D(t)$ the direct transmission matrix. A block diagram representation of equations (3) and (4) is shown in Figure 1.3. If vector functions f and g do not involve time t explicitly then the system is called a time-invariant system.

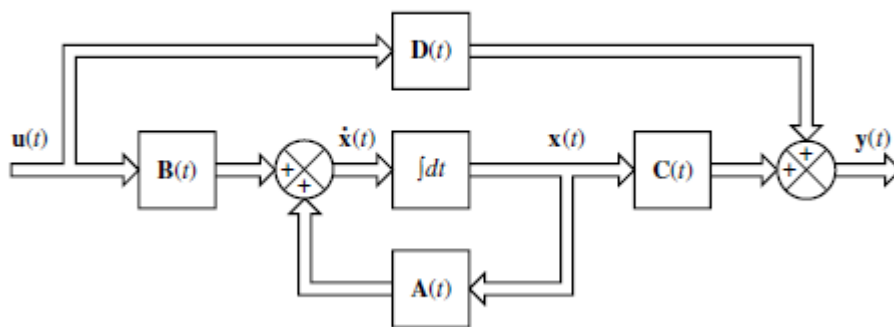

Figure 1.3 the linear, continuous time control system represented in state space

Definition 1.12

Digital Control: In most modern engineering systems, there is a need to control the evolution with time of one or more of the system variables. Controllers are required to ensure satisfactory transient and steady-state behavior for these engineering systems. To guarantee satisfactory performance in the presence of disturbances and model uncertainty, most controllers in use today employ some form of negative feedback. A sensor is needed to measure the controlled variable and compare its behavior to a reference signal. Control action is based on an error signal defined as the difference between the reference and the actual values. The controller that manipulates the error signal to determine the desired control action has classically been an analog system, which includes electrical, fluid, pneumatic, or mechanical components. These systems all have analog inputs and outputs (i.e., their input and output signals are defined over a continuous time interval and have values that are defined over a continuous range of amplitudes). In the past few decades, analog controllers have often been replaced by digital controllers whose inputs and outputs are defined at discrete time instances. The digital controllers are in the form of digital circuits, digital computers, or microprocessors. Digital processing of control signals involves addition and multiplication by stored numerical values. The errors that result from digital representation and arithmetic are negligible. By contrast, the processing of analog signals is performed using components such as resistors and capacitors with actual values that vary significantly from the nominal design values. The speed of computer hardware has increased exponentially since the 1980s. This increase in processing speed has made it possible to sample and process control signals at very high speeds. Because the interval between samples, the sampling period, can be made very small, digital controllers achieve performance that is essentially the same as that based on continuous monitoring of the controlled variable.

Definition 1.13

Cost: Although the prices of most goods and services have steadily increased, the cost of digital circuitry continues to decrease. Advances in very large scale

integration (VLSI) technology have made it possible to manufacture better, faster, and more reliable integrated circuits and to offer them to the consumer at a lower price. This has made the use of digital controllers more economical even for small, low-cost applications.

Definition 1.14

System Order: The order of the system is defined by the highest degree of the linear differential equation that describes the system. In a transfer function representation, the order is the highest exponent in the transfer function. In a proper system, the system order is defined as the degree of the denominator polynomial. In a state-space equation, the system order is the number of state-variables used in the system. The order of a system will frequently be denoted with N , although these variables are also used for other purposes. A proper system is a system where the degree of the denominator is larger than or equal to the degree of the numerator polynomial.

Definition 1.15

A strictly proper system: Is a system where the degree of the denominator polynomial is larger than (but never equal to) the degree of the numerator polynomial. A biproper system is a system where the degree of the denominator polynomial equals the degree of the numerator polynomial. It is important to note that only proper systems can be physically realized. In other words, a system that is not proper cannot be built. It makes no sense to spend a lot of time designing and analyzing imaginary systems.

Definition 1.16

Disturbances: A disturbance is a signal that tends to adversely affect the value of the output of a system. If a disturbance is generated within the system, it is called internal, while an external disturbance is generated outside the system.

1.5 Classification of Control Systems

An Open-Loop Control System

Those systems in which the output has no effect on the control action are called open-loop control systems. In other words, in an open loop control system the output is neither measured nor fed back for comparison with the input. One practical example is a washing machine. Soaking, washing, and rinsing in the washer operate on a time basis. The machine does not measure the output signal, that is, the cleanliness of the clothes. utilizes a controller or control actuator to obtain the desired response. The open-loop control system utilizes an actuating device to control the process directly without using device. An open-loop control system uses a controller and an actuator to obtain the desired response.

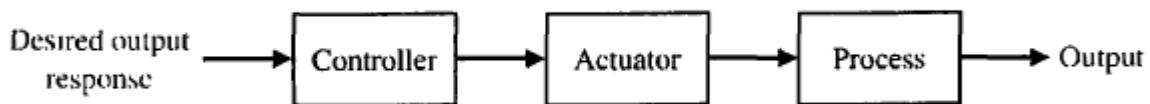

Figure 1.2 Open-loop control systems (without feedback)

A closed-loop control system

Feedback control systems are often referred to as closed-loop control systems. In practice, the terms feedback control and closed-loop control are used interchangeably. In a closed-loop control system the actuating error signal, which is the difference between the input signal and the feedback signal (which may be the output signal itself or a function of the output signal and its derivatives and/or integrals), is fed to the controller so as to reduce the error and bring the output of the system to a desired value. The term closed-loop control always implies the use of feedback control action in order to reduce system error. Utilizes an additional measure of the actual output to compare the actual output with the desired output response. The measure of the output is called the feedback signal.

Inputs and Outputs

Systems can also be categorized by the number of inputs and the number of outputs the system has. Consider a television as a system, for instance. The

system has two inputs: the power wire and the signal cable. It has one output: the video display. A system with one input and one output is called single-input, single output, or SISO. A system with multiple inputs and multiple outputs is called multi-input, multi-output, or MIMO.

A simple closed-loop feedback control system is a feedback control system is a control system that tends to maintain a prescribed relationship of one system variable to another by comparing functions of these variables and using the difference as a means of control. With an accurate sensor, the measured output is a good approximation of the actual output of the system. A feedback control system often uses a function of a prescribed relationship between the output and reference input to control the process. Often the difference between the output of the process under control and the reference input is amplified and used to control the process so that the difference is continually reduced. In general, the difference between the desired output and the actual output is equal to the error, which is then adjusted by the controller. The output of the controller causes the actuator to modulate the process in order to reduce the error. The sequence is such, for instance, that if a ship is heading incorrectly to the right, the rudder is actuated to direct the ship to the left. The system shown in Figure 1.3 is a negative feedback control system, because the output is subtracted from the input and the difference is used as the input signal controller. The Feedback concept has been the foundation for control system analysis.

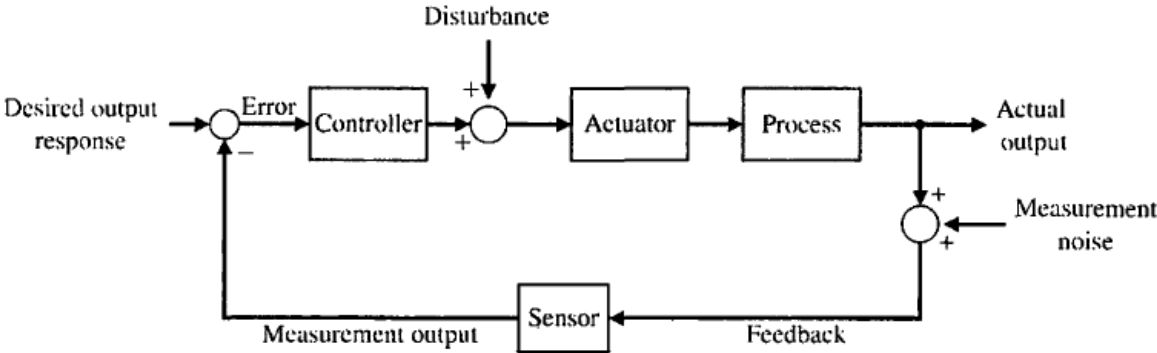

Figure 1.3 Closed-loop feedback control system (with feedback)

The feedback system in Figures 1.3 is single-loop feedback systems. Many feedback control systems contain more than one feedback loop. A common multi loop feedback control system is illustrated in Figure 1.4 with an inner loop and an outer loop. Other varieties of multi loop feedback systems are considered throughout this reach as they represent more practical situations found in real-world applications. However, we use the single-loop feedback system for learning about the benefits of feedback control systems since the outcomes readily extend to multi loop systems.

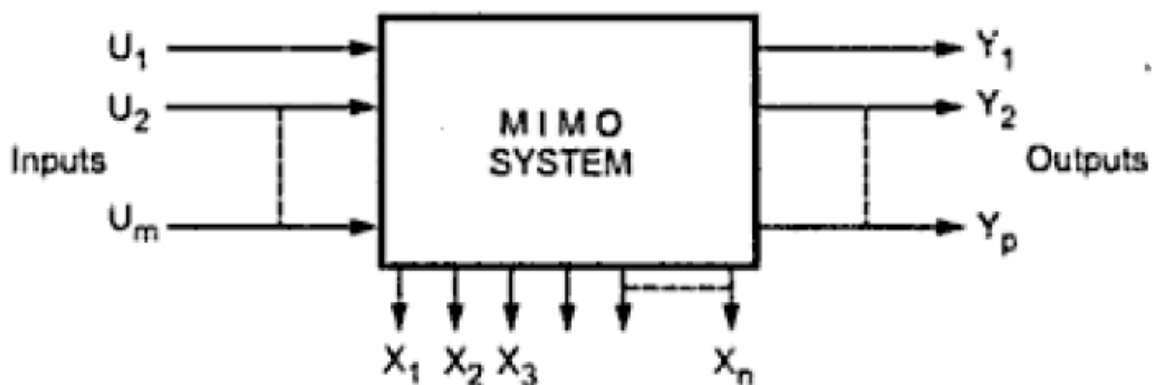

Figure 1.4 Multivariable control systems

Due to the increasing complexity of the system under control and the interest in achieving optimum performance, the importance of control system engineering has grown in the past decade. Furthermore, as the systems become more complex, the interrelationship of many controlled variables must be considered in the control scheme.

Definition 1.17

Linear Systems: A system is called linear if the principle of superposition applies. The principle of superposition states that the response produced by the simultaneous application of two different forcing functions is the sum of the two individual responses. Hence, for the linear system, the response to several inputs can be calculated by treating one input at a time and adding the results. It is this principle that allows one to build up complicated solutions to the linear differential equation from simple solutions.

Definition 1.18

Nonlinear Systems: A system is nonlinear if the principle of superposition does not apply. Thus, for a nonlinear system the response to two inputs cannot be calculated by treating one input at a time and adding the results. Although many physical relationships are often represented by linear equations, in most cases actual relationships are not quite linear. In fact, a careful study of physical systems reveals that even so-called “linear systems” are really linear only in limited operating ranges. In practice, many electromechanical systems, hydraulic systems, pneumatic systems, and so on, involve nonlinear relationships among the variables. For example, the output of a component may saturate for large input signals. There may be a dead space that affects small signals. (The dead space of a component is a small range of input variations to which the component is insensitive.) Square-law nonlinearity may occur in some components. For instance, dampers used in physical systems may be linear for low-velocity operations but may become nonlinear at high velocities, and the damping force may become proportional to the square of the operating velocity.

Linear Time-Invariant Systems and Linear Time-Varying Systems

A differential equation is linear if the coefficients are constants or functions only of the independent variable. Dynamic systems that are composed of linear time-invariant lumped-parameter components may be described by linear time-invariant differential equations that is, constant-coefficient differential equations. Such systems are called linear time-invariant (or linear constant-coefficient systems). Systems that are represented by differential equations whose coefficients are functions of time are called linear time-varying systems. An example of a time-varying control system is a spacecraft control system.

Definition 1.19

A feedback control system: Is a control system that tends to maintain a relationship of one system variable to another by comparing functions of these variables and using the difference as a means of control. As the system is

becoming more complex, the interrelationship of many controlled variables may be considered in the control scheme.

Definition 1.20

Step Response: The step response of a system is most frequently used to analyze systems, and there is a large amount of terminology involved with step responses. When exposed to the step input, the system will initially have an undesirable output period known as the transient response. The transient response occurs because a system is approaching its final output value. The steady-state response of the system is the response after the transient response has ended. The amount of time it takes for the system output to reach the desired value (before the transient response has ended, typically) is known as the rise time. The amount of time it takes for the transient response to end and the steady-state response to begin is known as the settling time.

Definition 1.21

Percent Overshoot: Under damped systems frequently overshoot their target value initially. This initial surge is known as the "overshoot value". The ratio of the amount of overshoot to the target steady-state value of the system is known as the percent overshoot. Percent overshoot represents an overcompensation of the system, and can output dangerously large output signals that can damage a system. Percent overshoot is typically denoted with the term P_0 .

Definition 1.22

Settling Time: After the initial rise time of the system, some systems will oscillate and vibrate for an amount of time before the system output settles on the final value. The amount of time it takes to reach steady state after the initial rise time is known as the settling time. Notice that damped oscillating systems may never settle completely, so we will define settling time as being the amount of time for the system to reach, and stay in, a certain acceptable range. The settling time will be denoted as t_s .

Definition 1.23

Steady-State Error: Usually, the letter e or E will be used to denote error values. Sometimes a system might never achieve the desired steady state value, but instead will settle on an output value that is not desired. The difference between the steady-state output value to the reference input value at steady state is called the steady state error of the system. We will use the variable e_{ss} to denote the steady-state error of the system.

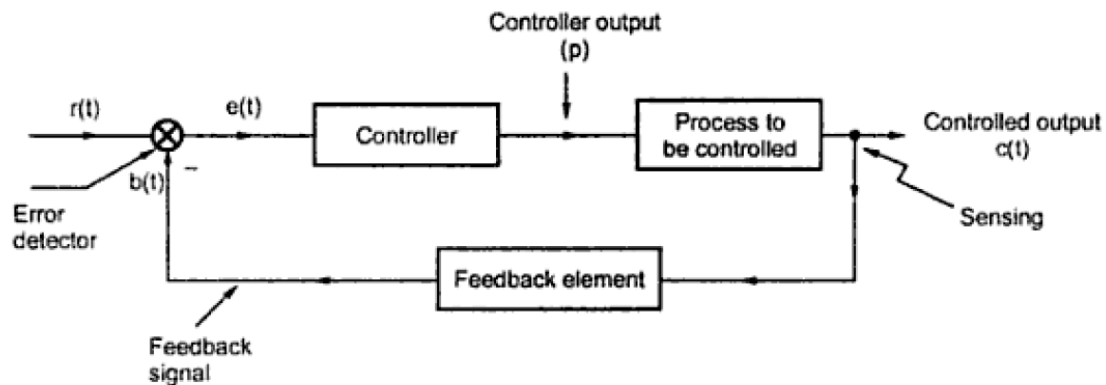

Figure 1-5 control system

The error detector compares the feedback signal $b(t)$ with the reference input $r(t)$ to generate an error $e(t) = r(t) - b(t)$

This gives an absolute indication of an error. The rang of the measured variable $b(t)$ is also called span Thus $span = b_{max} - b_{min}$

Hence error can be expressed as percent of span as

$$e_p = \frac{r - b}{b_{max} - b_{min}} \times 100$$

Where e_p is error as % of span. Errors in a control system can be attributed to many factors. Changes in the reference input will cause unavoidable errors during transient periods and may also cause steady state errors. Imperfections in the system components, such as static friction, backlash, and amplifier drift, as well as aging or deterioration, will cause errors at steady state.

Definition 1.24

Controller output rang: Similar to the controlled variable a rang is associated with a controller output variable. It is also specified in terms of the maximum and minimum values. But often the controller output is expressed as a percentage where minimum controller output is 0% and maximum controller output is 100%. But 0% controller output does not mean zero output. The controller output as a percent of full scale when the output changes within the specified rang is expressed as

$$p = \frac{u - u_{\min}}{u_{\max} - u_{\min}} \times 100$$

Where p = controller output as a percent of full scale

u = value of the output

u_{\max} = maximum value of controlling variable

u_{\min} = minimum value of controlling variable

Definition 1.25

Block Diagrams: A block diagram of a system is a pictorial representation of the functions performed by each component and of the flow of signals. Such a diagram depicts the interrelationships that exist among the various components. Differing from a purely abstract mathematical representation, a block diagram has the advantage of indicating more realistically the signal flows of the actual system. In a block diagram all system variables are linked to each other through functional blocks. The functional block or simply block is a symbol for the mathematical operation on the input signal to the block that produces the output. The transfer functions of the components are usually entered in the corresponding blocks, which are connected by arrows to indicate the direction of the flow of signals. Note that the signal can pass only in the direction of the arrows. Thus a block diagram of a control system explicitly shows a unilateral property. Figure 1-1 shows an element of the block diagram. The arrowhead pointing toward the

block indicates the input, and the arrowhead leading away from the block represents the output. Such arrows are referred to as signals.

Definition 1.26 Block Diagram of a Closed-Loop System

Figure1-5 shows an example of a block diagram of a closed-loop system. The output $C(s)$ is feedback to the summing point, where it is compared with the reference input $R(s)$. The closed-loop nature of the system is clearly indicated by the figure. The output of the block $C(s)$ in this case, is obtained by multiplying the transfer function $G(s)$ by the input to the block $E(s)$. Any linear control system may be represented by a block diagram consisting of blocks, summing points, and branch points. When the output is fed back to the summing point for comparison with the input, it is necessary to convert the form of the output signal to that of the input signal. For example, in a temperature control system, the output signal is usually the controlled temperature. The output signal, which has the dimension of temperature, must be converted to a force or position or voltage before it can be compared with the input signal. This conversion is accomplished by the feedback element whose transfer function is $H(s)$, as shown in Figure 1–4. The role of the feedback element is to modify the output before it is compared with the input. In the present example, the feedback signal that is fed back to the summing point for comparison with the input is $B(s) = H(s)C(s)$

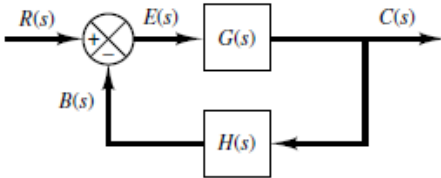

Figure1-6 Block diagram of a closed-loop system

Definition 1.27: State Diagram Representation

State diagram of a linear time invariant continuous system is discussed here for the sake of simplicity. It is a proper interconnection of three basic units.

1. Scalars
2. Adders

3. Integrators

Scalars are nothing but like amplifiers having required gain

Scalar

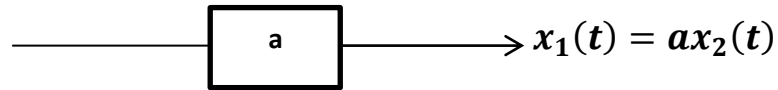

Adder

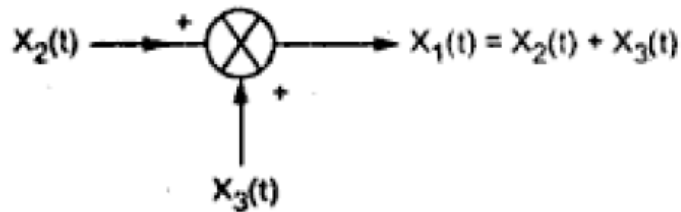

Integrator

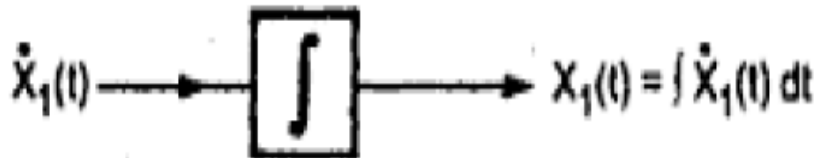

1-5 Singularity Function

Steps, Ramps and Impulses

In the study of control systems and the equations which describe them a particular family of function called singularity functions is used extensively. Each member of this family is related to the others by one or more integrations or differentiations. The three most widely used singularity functions are the unit step, the unit impulse and unit ramp.

Definition

A unit step function $I(t - t_0)$ is defined by

$$I(t - t_0) = \begin{cases} 1 & \text{for } t > t_0 \\ 0 & \text{for } t \leq 0 \end{cases}$$

The unit step function is illustrated in figure below

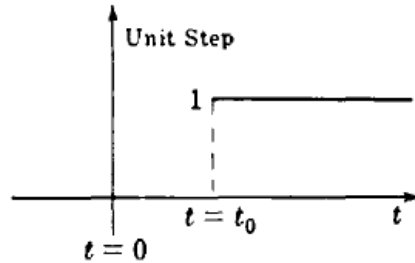

A unit ramp function is the integral of a unit step function

$$\int_{-\infty}^t I(\tau - t_0) d\tau = \begin{cases} t - t_0 & t > t_0 \\ 0 & t \leq 0 \end{cases}$$

The unit ramp function is illustrated in fig below

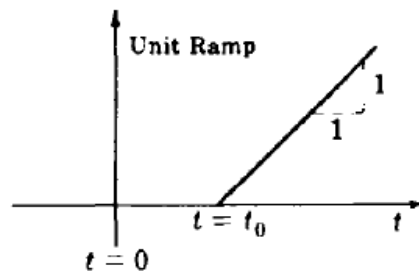

The unit impulse function $\delta(t)$ defined by

$$\delta(t) = \lim_{\Delta t \rightarrow 0} \left[\frac{I(t) - I(t - \Delta t)}{\Delta t} \right]$$

Where $I(t)$ is the unit step function

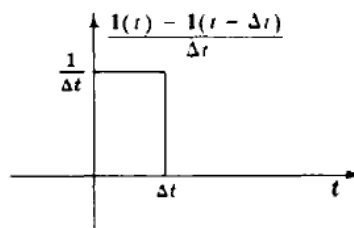

1.6 The Laplace transform

The Laplace transform method is an operational method that can be used advantageously for solving linear differential equations. By use of Laplace transforms, we can convert many common functions, such as sinusoidal functions, damped sinusoidal functions, and exponential functions, into algebraic functions of a complex variable s . Operations such as differentiation and integration can be replaced by algebraic operations in the complex plane. Thus, a linear differential equation can be transformed into an algebraic equation in a complex variable s . If the algebraic equation in s is solved for the dependent variable, then the solution of the differential equation (the inverse Laplace transform of the dependent variable) may be found by use of a Laplace transform table or by use of the partial-fraction expansion technique.

An advantage of the Laplace transform method is that it allows the use of graphical techniques for predicting the system performance without actually solving system differential equations. Another advantage of the Laplace transform method is that, when we solve the differential equation, both the transient component and steady-state component of the solution can be obtained simultaneously.

1-7 Transfer Function and Impulse Response Function

In control theory, functions called transfer functions are commonly used to characterize the input-output relationships of components or systems that can be described by linear, time-invariant, differential equations. We begin by defining the transfer function and follow with a derivation of the transfer function of a differential equation system. Then we discuss the impulse-response function.

Definition 1.26

Transfer Function: The transfer function of a linear, time-invariant, differential equation system is defined as the ratio of the Laplace transform of the output (response function) to the Laplace transform of the input (driving function) under the assumption that all initial conditions are zero. Consider the linear time-invariant system defined by the following differential equation:

$$\begin{aligned}
 & a_0 y^{(n)} + a_1 y^{(n-1)} + \dots + a_{n-1} y' + a_n y \\
 & = b_0 x^{(m)} + b_1 x^{(m-1)} + \dots + b_{m-1} x' + b_m x
 \end{aligned} \tag{1-7}$$

Where y is the output of the system and x is the input. The transfer function of this system is the ratio of the Laplace transformed output to the Laplace transformed input when all initial conditions are zero, or

$$\text{Transfer function } G(s) = \frac{\mathcal{L}[\text{output}]}{\mathcal{L}[\text{input}]_{\text{zero initial conditions}}}$$

$$\frac{Y(s)}{X(s)} = \frac{b_0 s^m + b_1 s^{m-1} + \dots + b_{m-1} s + b_m}{a_0 s^n + a_1 s^{n-1} + \dots + a_{n-1} s + a_n} \tag{1-8}$$

By using the concept of transfer function, it is possible to represent system dynamics by algebraic equations in s . If the highest power of s in the denominator of the transfer function is equal to n , the system is called an n th-order system.

Convolution Integral

For a linear, time-invariant system the transfer function $G(s)$ is

$$G(s) = \frac{Y(s)}{X(s)}$$

Where $X(s)$ the Laplace is transform of the input to the system and $Y(s)$ is the Laplace transform of the output of the system, where we assume that all initial conditions involved are zero. It follows that the output $Y(s)$ can be written as the product of $G(s)$ and $X(s)$

$$Y(s) = G(s)X(s)$$

Definition 1.27

Poles of a Transfer Function

The poles of a transfer function are: (1) the values of the Laplace transform variable s , that cause the transfer function to become infinite or (2) any roots of the denominator of the transfer function that are common to roots of the numerator. Strictly speaking, the poles of a transfer function satisfy part (1) of the definition. For example, the roots of the characteristic polynomial in the

denominator are values of s that make the transfer function infinite, so they are thus poles.

Definition 1.28

Zeros of a Transfer Function

The zeros of a transfer function are: (1) the values of the Laplace transform variables, that cause the transfer function to become zero, or (2) any roots of the numerator of the transfer function that are common to roots of the denominator.

Example 1.1

Given the transfer function $G(s)$ in Figure (a), a pole exists at $s = -5$, and a zero exists at -2 . These values are plotted on the complex S -plane in Figure (b). To show the properties of the poles and zeros, let us find the unit step response of the system. Multiplying the transfer function by a step function yields

$$\begin{aligned} C(s) &= \frac{(s+2)}{s(s+5)} = \frac{A}{s} + \frac{B}{s+5} & (1-9) \\ &= \frac{2/5}{s} + \frac{3/5}{s+5} \end{aligned}$$

Where

$$A = \frac{(s+2)}{(s+5)} \Big|_{s \rightarrow 0} = \frac{2}{5}$$

Thus

$$B = \frac{(s+2)}{s} \Big|_{s \rightarrow 5} = \frac{3}{5}$$

$$C(t) = \frac{2}{5} + \frac{3}{5} e^{-5t}$$

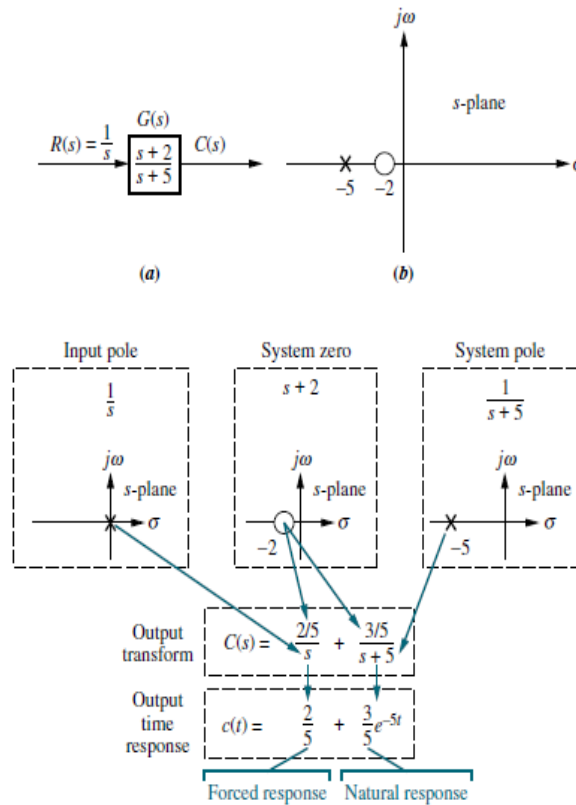

Figure 1-7 (a) System showing input and output ;(b) pole-zero plot of the system; (c) evolution of a system response.

1.8 Transient and Steady-State Response Analyses:

In this section it was stated that the first step in analyzing a control system was to derive a mathematical model of the system. Once such a model is obtained, various methods are available for the analysis of system performance. In practice, the input signal to a control system is not known ahead of time but is random in nature, and the instantaneous input cannot be expressed analytically. Only in some special cases is the input signal known in advance and expressible analytically or by curves, such as in the case of the automatic control of cutting tools. In analyzing and designing control systems, we must have a basis of comparison of performance of various control systems. This basis may be set up by specifying particular test input signals and by comparing the responses of various systems to these input signals. Many design criteria are based on the response to such test signals or on the response of systems to changes in initial conditions (without any test signals).The use of test signals can be justified

because of a correlation existing between the response characteristics of a system to a typical test input signal and the capability of the system to cope with actual input signals. The time response of a control system consists of two parts: the transient response and the steady-state response. By transient response, we mean that which goes from the initial state to the final state. By steady-state response, we mean the manner in which the system output behaves as t approaches infinity. Thus the system response $c(t)$ may be written as

$$C(t) = c_{tr}(t) + c_{ss}(t) \quad (1 - 10)$$

Where the first term on the right-hand side of the equation is the transient response and the second term is the steady-state response.

Impulse-Response Function

Consider the output (response) of a linear time invariant system to a unit-impulse input when the initial conditions are zero. Since the Laplace transform of the unit-impulse function is unity, the Laplace transform of the output of the system is

$$Y(s) = G(s) \quad (1 - 11)$$

The inverse Laplace transform of the output given by Equation (1-11) gives the impulse response of the system. The inverse Laplace transforms of $G(s)$, or

$$L^{-1}(G(s)) = g(t)$$

is called the impulse-response function. This function $g(t)$ is also called the weighting function of the system. The impulse-response function $g(t)$ is thus the response of a linear time-invariant system to a unit-impulse input when the initial conditions are zero. The Laplace transform of this function gives the transfer function. Therefore, the transfer function and impulse-response function of a linear, time-invariant system contain the same information about the system dynamics. It is hence possible to obtain complete information about the dynamic characteristics of the system by exciting it with an impulse input and measuring the response. (In practice, a pulse input with a very short duration compared with the significant time constants of the system can be considered an impulse).

Open-Loop Transfer Function and Feed forward Transfer Function

The ratios of the feedback signal $B(s)$ to the actuating error signal $E(s)$ is called the open-loop transfer function. That is,

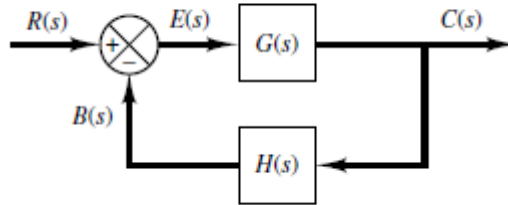

Figure 1-8 open-loop control system

Open-loop transfer function

$$\frac{B(s)}{E(s)} = G(s)H(s)$$

The ratio of the output $C(s)$ to the actuating error signal $E(s)$ is called the feed forward Transfer function, so that feed forward transfer function

$$\frac{C(s)}{E(s)} = G(s)$$

If the feedback transfers function $H(s)$ is unity, then the open-loop transfer function and the feed forward transfer function are the same.

Closed-Loop Transfer Function

For the system shown in Figure blew, the output $C(s)$ and input $R(s)$ are related as follows: since

$$C(s) = G(s)E(s)$$

$$E(s) = R(s) - B(s)$$

$$= R(s) - H(s)C(s)$$

Eliminating $E(s)$ from these equations gives

$$C(s) = G(s)[R(s) - H(s)C(s)]$$

or

$$\frac{C(s)}{R(s)} = \frac{G(s)}{1 + G(s)H(s)}$$

$$C(s) = \frac{G(s)}{1 + G(s)H(s)}R(s)$$

The transfer function relating $C(s)$ to $R(s)$ is called the closed-loop transfer function. It relates the closed-loop system dynamics to the dynamics of the feed forward elements and feedback elements. Thus the output of the closed-loop system clearly depends on both the closed-loop transfer function and the nature of the input.

1.9 First –Order Systems

Consider the first-order system shown in Figure 1.9(a). Physically, this system may represent an RC circuit, thermal system, or the like. A simplified block diagram is shown in Figure 1.9(b). The input-output relationship is given by

$$\frac{C(s)}{R(s)} = \frac{1}{Ts + 1} \quad (1 - 12)$$

In the following, we shall analyze the system responses to such inputs as the unit-step, unit-ramp, and unit-impulse functions. The initial conditions are assumed to be zero. Note that all systems having the same transfer function will exhibit the same output in response to the same input. For any given physical system, the mathematical response can be given a physical interpretation.

Unit-Step Response of First-Order Systems

Since the Laplace transform of the unit-step function is $1/s$, substituting $R(s) = 1/s$ into Equation (1-12), we obtain

$$C(s) = \frac{1}{Ts + 1} \frac{1}{s}$$

Expanding $C(s)$ into partial fractions gives

$$C(s) = \frac{1}{s} - \frac{T}{Ts + 1} = \frac{1}{s} - \frac{1}{s + (\frac{1}{T})} \quad (1 - 13)$$

Taking the inverse Laplace transform of Equation (1-13), we obtain

$$C(t) = 1 - e^{-t/T} \quad \text{for } t \geq 0 \quad (1 - 14)$$

Equation (1-14) states that initially the output $c(t)$ is zero and finally it becomes unity. One important characteristic of such an exponential response curve $c(t)$ is that at $t = T$ the value of $c(t)$ is 0.632, or the response $c(t)$ has reached 63.2% of its total change. This may be easily seen by substituting $t = T$ in $c(t)$. That is,

$$C(T) = 1 - e^{-1} = 0.632$$

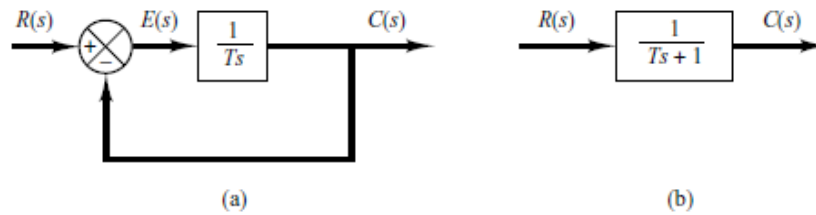

Figure 1-9 Unit-Ramp Response of First-Order Systems

Since the Laplace transform of the unit-ramp function is $1/s^2$, we obtain the output of the system of Figure (a) as

$$C(s) = \frac{1}{Ts + 1} \frac{1}{s^2}$$

Expanding $C(s)$ into partial fractions gives

$$C(s) = \frac{1}{s^2} - \frac{T}{s} + \frac{T^2}{Ts + 1} \quad (1 - 15)$$

Taking the inverse Laplace transform of Equation (1-15), we obtain

$$C(t) = t - T + Te^{-t/T} \quad \text{for } t \geq 0 \quad (1 - 16)$$

The error signal $e(t)$ is then

$$e(t) = r(t) - c(t)$$

$$C(t) = T(1 - e^{-t/T})$$

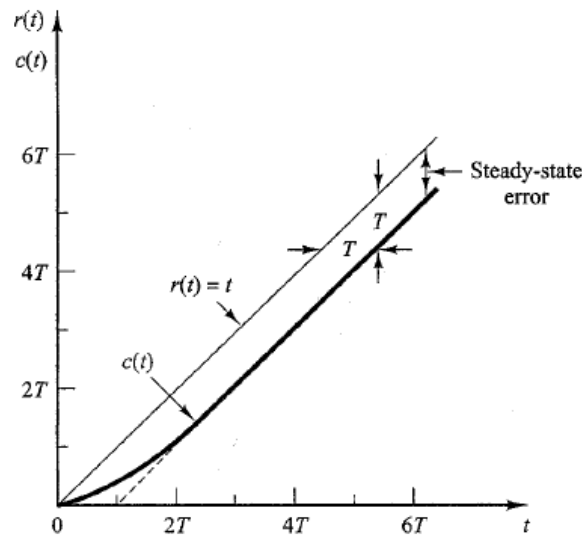

Figure 1-10 Unit-ramp response of the system

As t approaches infinity, $e^{-t/T}$ approaches zero, and thus the error signal $e(t)$ approaches or

$$e(\infty) = T$$

The error in following the unit-ramp input is equal to T for sufficiently large t . The smaller the time constant T , the smaller the steady-state error in following the ramp input.

Unit-Impulse Response of First-Order Systems For the unit-impulse input, $R(s) = 1$ and the output of the system of Figure (a) can be obtained as

$$C(s) = \frac{1}{Ts + 1} \quad (1 - 17)$$

The inverse Laplace transform of Equation (1-17) gives

$$C(t) = \frac{1}{T} e^{-t/T} \quad \text{for } t \geq 0 \quad (1 - 18)$$

The response curve given by Equation (1-18) is shown in Figure(1-11) .

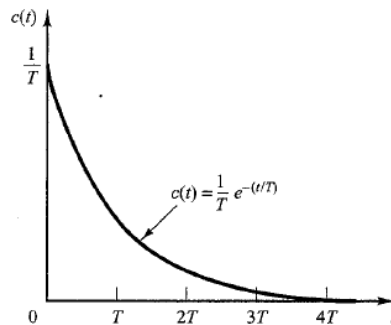

Figure 1-11 Unit-impulse response of the system

The Property of Linear Time-Invariant Systems

In the analysis above, it has been shown that for the unit-ramp input the output $C(t)$ is

$$C(t) = t - T + Te^{-t/T} \quad \text{for } t \geq 0$$

For the unit-step input, which is the derivative of unit-ramp input, the output $C(t)$ is

$$C(t) = 1 - e^{-t/T} \quad \text{for } t \geq 0$$

Finally, for the unit-impulse input, which is the derivative of unit-step input, the output $C(t)$ is

$$C(t) = \frac{1}{T} e^{-t/T} \quad \text{for } t \geq 0$$

Comparing the system responses to these three inputs clearly indicates that the response to the derivative of an input signal can be obtained by differentiating the response of the system to the original signal. It can also be seen that the response to the integral of the original signal can be obtained by integrating the response of the system to the original signal and by determining the integration constant from the zero output initial condition. This is a property of linear time-invariant systems. Linear time-varying systems and nonlinear systems do not possess this property.

Example 1.2

Give the following differential equation, solve for $y(t)$ all initial conditions are zero use the Laplace transform

$$\frac{d^2y}{dt^2} + 12\frac{dy}{dt} + 32y = 32u(t)$$

Solution

$$Y(0) = 0 \quad dy/dt = 0$$

$$\text{Laplace transforms} \quad s^2Y(s) + 12Y(s) + 32Y(s) = \frac{32}{s}$$

$$\text{solving for the response } Y(s) \text{ Yields} \quad Y(s) = \frac{32}{s(s^2 + 12s + 32)} = \frac{32}{s(s+4)(s+8)}$$

To solve for $Y(t)$ then

$$Y(s) = \frac{32}{s(s^2 + 12s + 32)} = \frac{32}{s(s+4)(s+8)}$$

then

$$Y(s) = \frac{32}{s(s+4)(s+8)} = \frac{k_1}{s} + \frac{k_2}{s+4} + \frac{k_3}{s+8}$$

Where from equation

$$k_1 = \left. \frac{32}{(s+4)(s+8)} \right|_{s=0} = 1$$

$$k_2 = \left. \frac{32}{s(s+8)} \right|_{s=-4} = -2$$

$$k_3 = \left. \frac{32}{s(s+4)} \right|_{s=-8} = 1$$

$$Y(s) = \frac{1}{s} - \frac{2}{s+4} + \frac{1}{s+8}$$

$Y(t)$ is sum of the inverse Laplace transform of each term

$$Y(t) = (1 - 2e^{-4t} + e^{-8t})u(t)$$

Stability

Control systems theory as we know it today began to crystallize in the latter half of the nineteenth century. In 1868, James Clerk Maxwell published the stability criterion for a third-order system based on the coefficients of the differential equation. In 1874, Edward John Routh, using a suggestion from William Kingdom Clifford that was ignored earlier by Maxwell, was able to extend the stability criterion to fifth-order systems. In 1877, the topic for the Adams Prize was “The Criterion of Dynamical Stability.” The second method of stability is **root locus** method provides a quick means of predicting the closed-loop behavior of a system based on its open-loop poles and zeros.

Second –Order Systems

In this section, we shall obtain the response of a typical second-order control system to a step input, ramp input, and impulse input. Here we consider a servo system as an example of a second-order system.

Servo System The servo system shown in Figure (a) consists of a proportional controller and load elements (inertia and viscous friction elements). Suppose that we wish to control the output position c in accordance with the input position r . The equation for the load elements is

$$Jc'' + Bc' = T$$

Where T is the torque produced by the proportional controller whose gain is K . By taking Laplace transforms of both sides of this last equation, assuming the zero initial conditions, we obtain

$$Js^2C(s) + BsC(s) = T(s)$$

So the transfer function between $C(s)$ and $T(s)$ is

$$\frac{C(s)}{T(s)} = \frac{1}{s(Js + B)}$$

By using this transfer function. Figure (a) can be redrawn as in Figure (b), which can be modified to that shown in Figure (c). The closed-loop transfer function is then obtained as

$$\frac{C(s)}{R(s)} = \frac{K}{Js^2 + Bs + K} = \frac{K/J}{s^2 + (B/J)s + (K/J)}$$

Such a system where the closed-loop transfer function possesses two poles is called a second-order system. (Some second-order systems may involve one or two zeros.)

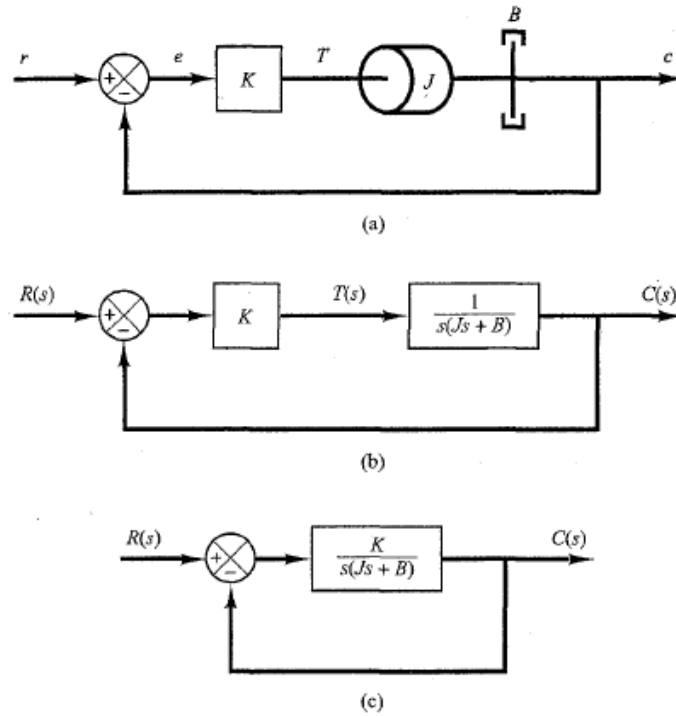

Figure 1-12 (a) Servo system, (b) block diagram; (c) simplified block diagram.

Step Response of Second-Order System.

The closed-loop transfer function of the system shown in Figure (c) above is

$$\frac{C(s)}{R(s)} = \frac{K}{Js^2 + Bs + K} \quad (1 - 19)$$

Which can be rewritten as

$$\frac{C(s)}{R(s)} = \frac{\frac{K}{J}}{\left[s + \frac{B}{2J} + \sqrt{\left(\frac{B}{2J}\right)^2 - \frac{K}{J}} \right] \left[s + \frac{B}{2J} - \sqrt{\left(\frac{B}{2J}\right)^2 - \frac{K}{J}} \right]}$$

The closed-loop poles are complex conjugates if $B^2 - 4JK < 0$ and they are real if $B^2 - 4JK \geq 0$. In the transient-response analysis, it is convenient to write

$$\frac{K}{J} = \omega_n^2 \frac{B}{J} = 2\zeta\omega_n = 2\sigma$$

Where σ is called the attenuation; ω_n the undamped natural frequency and ζ the damping ratio of the system. The damping ratio is the ratio of the actual damping

B to the critical damping $B_c = 2\sqrt{JK}$

$$\zeta = \frac{B}{B_c} = 2\sqrt{JK}$$

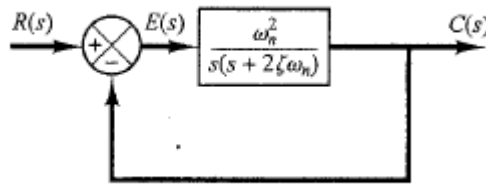

Figure 1-13 second order system

In terms of ζ and ω_n the system shown in Figure (c) can be modified to that shown in Figure, and the closed-loop transfer function $C(s)/R(s)$ given by

$$\frac{C(s)}{R(s)} = \frac{\omega_n^2}{s^2 + 2\zeta\omega_n s + \omega_n^2} \quad (1 - 20)$$

This form is called the standard form of the second-order system. The dynamic behavior of the second-order system can then be described in terms of two parameters ζ and ω_n . If $0 < \zeta < 1$, the closed-loop poles are complex conjugates and lie in the left-half s plane. The system is then called under damped, and the transient response is oscillatory, If $\zeta = 0$, the transient response does not die out. If $\zeta = 1$, the system is called critically damped. Over damped systems correspond to $\zeta > 1$. We shall now solve for the response of the system shown in Figure() to a unit-step input. We shall consider three different cases: the underdamped ($0 < \zeta < 1$), critically damped ($\zeta = 1$), and overdamped ($\zeta > 1$) cases.

(1) Underdamped case ($0 < \zeta < 1$): In this case, $C(s)/R(s)$ can be written

$$\frac{C(s)}{R(s)} = \frac{\omega_n^2}{(s + \zeta\omega_n + i\omega_d)(s + \zeta\omega_n - i\omega_d)}$$

Where $\omega_d = \omega_n\sqrt{1 - \zeta^2}$. The frequency ω_d is called the damped natural Frequency.

For a unit-step input, $C(s)$ can be written

$$C(s) = \frac{\omega_n^2}{(s^2 + 2\zeta\omega_n s + \omega_n^2)s} \quad (1 - 21)$$

The inverse Laplace transform of equation (1-21) can be obtained easily if $C(s)$ is written in the following form:

$$\begin{aligned} C(s) &= \frac{1}{s} - \frac{s + 2\zeta\omega_n}{s^2 + 2\zeta\omega_n s + \omega_n^2} \\ &= \frac{1}{s} - \frac{s + \zeta\omega_n}{(s + \zeta\omega_n)^2 + \omega_d^2} - \frac{\zeta\omega_n}{(s + \zeta\omega_n)^2 + \omega_d^2} \end{aligned}$$

Thus

$$\begin{aligned} L^{-1}\left[\frac{s + \zeta\omega_n}{(s + \zeta\omega_n)^2 + \omega_d^2}\right] &= e^{-\zeta\omega_n t} \cos\omega_d t \\ L^{-1}\left[\frac{\omega_d}{(s + \zeta\omega_n)^2 + \omega_d^2}\right] &= e^{-\zeta\omega_n t} \sin\omega_d t \end{aligned}$$

Hence the inverse Laplace transform of equation(1-21) is obtained as

$$\begin{aligned} L^{-1}[s] &= c(t) \\ &= 1 - e^{-\zeta\omega_n t} \left(\cos\omega_d t + \frac{\zeta}{\sqrt{1 - \zeta^2}} \sin\omega_d t \right) \\ &= 1 - \frac{e^{-\zeta\omega_n t}}{\sqrt{1 - \zeta^2}} \sin\left(\omega_d t + \tan^{-1} \frac{\sqrt{1 - \zeta^2}}{\zeta} \right) \quad \text{for } t \geq 0 \quad (1 - 22) \end{aligned}$$

This result can be obtained directly by using a table of Laplace transforms, from equation (1-22), it can be seen that the frequency of transient oscillation is the damped natural frequency ω_d and thus varies with the damping ratio ζ . The error signal for this system is the difference between the input and output and is

$$\begin{aligned} e(t) &= r(t) - c(t) \\ &= e^{-\zeta\omega_n t} \left(\cos\omega_d t + \frac{\zeta}{\sqrt{1 - \zeta^2}} \sin\omega_d t \right) \quad \text{for } t \geq 0 \end{aligned}$$

This error signal exhibits a damped sinusoidal oscillation. At steady state, or at $t = \infty$ no error exists between the input and output. If the damping ratio ζ is equal to zero, the response becomes undamped and oscillations continue indefinitely. The response $c(t)$ for the zero damping case may be obtained by substituting $\zeta = 0$ in equation (1-22), yielding

$$c(t) = 1 - \cos\omega_n t \quad \text{for } t \geq 0 \quad (1 - 23)$$

Thus, from Equation (1-23), we see that ω_n , represents the undamped natural frequency of the system. That is, ω_n is that frequency at which the system output would oscillate if the damping were decreased to zero. If the linear system has any amount of damping, the undamped natural frequency cannot be observed experimentally. The frequency that may be observed is the damped natural frequency ω_d , which is equal to $\omega_n\sqrt{1-\zeta^2}$. This frequency is always lower than the undamped natural frequency. An increase in ζ would reduce the damped natural frequency ω_d . If ζ is increased beyond unity, the response becomes overdamped and will not oscillate.

(2) Critically damped case ($\zeta = 1$): If the two poles of $C(s)/R(s)$ are equal, the system is said to be a critically damped one.

For a unit-step input, $R(s) = 1/s$ and $C(s)$ can be written

$$\frac{\omega_n^2}{(s + \omega_n)^2 s} \quad (1 - 24)$$

The inverse Laplace transform of Equation (1-24) may be found as

$$C(t) = 1 - e^{-\omega_n t}(1 + \omega_n t) \quad \text{for } t \geq 0 \quad (1 - 25)$$

This result can also be obtained by letting ζ approach unity in equation (1-25) and by using the following limit:

$$\lim_{\zeta \rightarrow 1} \frac{\sin\omega_d t}{\sqrt{1-\zeta^2}} = \lim_{\zeta \rightarrow 1} \frac{\sin\omega_n\sqrt{1-\zeta^2}t}{\sqrt{1-\zeta^2}} = \omega_n t$$

(3) Overdamped case ($\zeta > 1$): In this case, the two poles of $C(s)/R(s)$ are negativereal and unequal. For a unit-step input, $R(s) = 1/s$ and $C(s)$ can be written

$$C(s) = \frac{\omega_n^2}{(s + \zeta\omega_n + \omega_n\sqrt{\zeta^2 - 1})(s + \zeta\omega_n - \omega_n\sqrt{\zeta^2 - 1})s} \quad (1 - 26)$$

The inverse Laplace transform of equation (1-26) is

$$\begin{aligned}
C(t) &= 1 + \frac{1}{2\sqrt{\zeta^2 - 1} \left(\zeta + \sqrt{\zeta^2 - 1} \right)} e^{-(\zeta + \sqrt{\zeta^2 - 1})\omega_n t} \\
&\quad - \frac{1}{2\sqrt{\zeta^2 - 1} \left(\zeta - \sqrt{\zeta^2 - 1} \right)} e^{-(\zeta - \sqrt{\zeta^2 - 1})\omega_n t} \\
&= 1 + \frac{\omega_n}{2\sqrt{\zeta^2 - 1}} \left(\frac{e^{-s_1 t}}{s_1} - \frac{e^{-s_2 t}}{s_2} \right) \quad \text{for } t \geq 0 \tag{1-27}
\end{aligned}$$

Where $s_1 = (\zeta + \sqrt{\zeta^2 - 1})\omega_n$ and $s_2 = (\zeta - \sqrt{\zeta^2 - 1})\omega_n$

Thus, the response $c(t)$ includes two decaying exponential terms. When ζ is appreciably greater than unity, one of the two decaying exponentials decreases much faster than the other, so the faster decaying exponential term (which corresponds to a smaller time constant) may be neglected. That is, if s_2 is located very much closer to the iw axis than $-s_1$ (which means $|s_2| < |s_1|$), then for an approximate solution we may neglect $-s_1$. This is permissible because the effect of $-s_1$ on the response is much smaller than that of $-s_2$, since the term involving s_1 in equation (1-20) decays much faster than the term involving s_2 . Once the faster decaying exponential term has disappeared, the response is similar to that of a first-order system, and $C(s)/R(s)$ may be approximated by

$$\frac{C(s)}{R(s)} = \frac{\zeta\omega_n - \omega_n\sqrt{\zeta^2 - 1}}{s + \zeta\omega_n - \omega_n\sqrt{\zeta^2 - 1}} = \frac{s_2}{s + s_2}$$

This approximate form is a direct consequence of the fact that the initial values and final values of both the original $C(s)/R(s)$ and the approximate one agree with each other. With the approximate transfer function $C(s)/R(s)$, the unit-step response can be obtained as

$$C(s) = \frac{\zeta\omega_n - \omega_n\sqrt{\zeta^2 - 1}}{s + \zeta\omega_n - \omega_n\sqrt{\zeta^2 - 1}}s$$

The time response $c(t)$ is then

$$C(t) = 1 - e^{-(\zeta - \sqrt{\zeta^2 - 1})\omega_n t} \quad \text{for } t \geq 0$$

This gives an approximate unit-step response when one of the poles of $C(s)/R(s)$ can be neglected.

1.10 Definitions of Transient-Response Specifications

In many practical cases, the desired performance characteristics of control systems are specified in terms of time-domain quantities. Systems with energy storage cannot respond instantaneously and will exhibit transient responses whenever they are subjected to inputs or disturbances. Frequently, the performance characteristics of a control system are specified in terms of the transient response to a unit-step input since it is easy to generate and is sufficiently drastic. (If the response to a step input is known, it is mathematically possible to compute the response to any input.) The transient response of a system to a unit-step input depends on the initial conditions. For convenience in comparing transient responses of various systems, it is a common practice to use the standard initial condition that the system is at rest initially with the output and all time derivatives thereof zero. Then the response characteristics of many systems can be easily compared. The transient response of a practical control system often exhibits damped oscillations before reaching steady state. In specifying the transient-response characteristics of a control system to a unit-step input, it is common to specify the following:

1. Delay time, t_d
2. Rise time, t_r
3. Peak time, t_p
4. Maximum overshoot, M_P
5. Settling time, t_s

These specifications are defined in what follows and are shown graphically in Figure .

1. Delay time, t_d The delay time is the time required for the response to reach half the final value the very first time.

2. Rise time, t_r . The rise time is the time required for the response to rise from 10%to 90%, 5% to 95%, or 0% to 100% of its final value. For under damped second order systems, the 0% to 100% rise time is normally used. For over damped systems, the 10% to 90% rise time is commonly used.

3. Peak time, t_p . The peak time is the time required for the response to reach the first peak of the overshoot.

4. Maximum (percent) overshoot, M_p The maximum overshoot is the maximum peak value of the response curve measured from unity. If the final steady-state value of the response differs from unity, then it is common to use the maximum percent overshoot. It is defined by

$$\frac{C(t_p) - C(\infty)}{C(\infty)} \times 100$$

The amount of the maximum (percent) overshoot directly indicates the relative stability of the system.

5. Settling time, t_s .The settling time is the time required for the response curve to reach and stay within a range about the final value of size specified by absolute percentage of the final value (usually 2% or 5%). The settling time is related to the largest time constant of the control system.

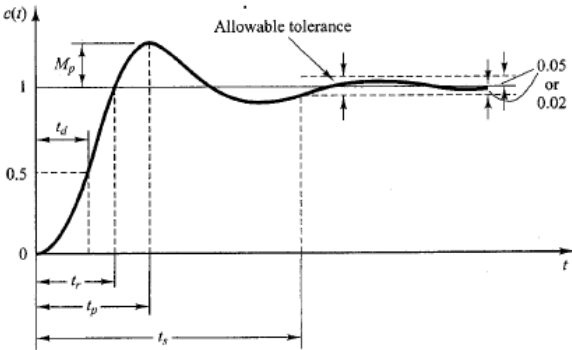

Figure 1-14 Unit-step response curve showing t_d , t_s , t_p , M_p , and t_r

1.11 Second-Order Systems and Transient-Response Specification

In the following, we shall obtain the rise time, peak time, maximum overshoot, and settling time of the second-order system given by Equation (1-20). These values will be obtained in terms of ζ and ω_n . The system is assumed to be under damped. Rise time t_r Referring to Equation (1-22), we obtain the rise time t_r by letting $C(t_r) = 1$.

$$C(t_r) = 1 = 1 - e^{-\zeta\omega_n t_r} \left(\cos\omega_d t_r + \frac{\zeta}{\sqrt{1-\zeta^2}} \sin\omega_d t_r \right) \text{ for } t \geq 0 \quad (1-28)$$

Since $e^{-\zeta\omega_n t_r} \neq 0$ we obtain from Equation (1-28) the following equation

$$\cos\omega_d t_r + \frac{\zeta}{\sqrt{1-\zeta^2}} \sin\omega_d t_r = 0$$

or

$$\tan\omega_d t_r = -\frac{\sqrt{1-\zeta^2}}{\zeta} = -\frac{\omega_d}{\sigma}$$

Thus, the rise time t_r is

$$t_r = \frac{1}{\omega_d} \tan^{-1} \left(\frac{\omega_d}{-\sigma} \right) = \frac{\pi - \beta}{\omega_d} \quad (1-29)$$

Peak time t_p referring to equation (1-22), we may obtain the peak time by differentiating (t) with respect to time and letting this derivative equal zero. Since

$$\begin{aligned} \frac{dc}{dt} &= \zeta\omega_n e^{-\zeta\omega_n t} \left(\cos\omega_d t + \frac{\zeta}{\sqrt{1-\zeta^2}} \sin\omega_d t \right) \\ &\quad + e^{-\zeta\omega_n t} \left(\omega_d \sin - \frac{\zeta\omega_d}{\sqrt{1-\zeta^2}} \cos\omega_d t \right) \end{aligned}$$

and the cosine terms in this last equation cancel each other, dc/dt , evaluated at $t = t_p$ can be simplified to

$$\left. \frac{dc}{dt} \right|_{t=t_p} = (\sin \omega_d t_p) \frac{\omega_n}{\sqrt{1-\zeta^2}} e^{-\zeta \omega_n t} = 0$$

This last equation yields the following equation

or

$$\sin \omega_d t_p = 0$$

$$\omega_d t_p = 0, \pi, 2\pi, 3\pi, \dots$$

Since the peak time corresponds to the first peak overshoot $\omega_d t_p = \pi$. Hence

$$t_p = \frac{\pi}{\omega_d}$$

The peak time corresponds to one-half cycle of the frequency of damped oscillation. Maximum overshoot M_p : The maximum overshoot occurs at the peak Time or at

$$t = t_p = \frac{\pi}{\omega_d}$$

Assuming that the final value of the output is unity, M_p is obtained from equation as

$$\begin{aligned} M_p &= c(t_p) - 1 \\ &= e^{\zeta \omega_n (\pi / \omega_d)} \left(\cos \pi + \frac{\zeta}{\sqrt{1-\zeta^2}} \sin \pi \right) \\ &= e^{-(\sigma / \omega_d) \pi} = e^{-(\zeta / \sqrt{1-\zeta^2}) \pi} \end{aligned}$$

The maximum percent overshoot is $e^{-(\sigma / \omega_d) \pi} \times 100\%$. If the final value $c(\infty)$ of the output is not unity, then we need to use the following equation

$$M_p = \frac{c(t_p) - c(\infty)}{c(\infty)}$$

Settling time t_s : For an under damped second-order system, the transient response is obtained from Equation (1-22) as

$$c(t) = 1 - \frac{e^{\zeta \omega_n t}}{\sqrt{1-\zeta^2}} \sin \left(\omega_d t + \tan^{-1} \frac{\sqrt{1-\zeta^2}}{\zeta} \right) \text{ for } t \geq 0$$

The curves $1 \pm \frac{e^{-\zeta\omega_n t}}{\sqrt{1-\zeta^2}}$ are the envelope curves of the transient response to a unit-step input. The response curve $c(t)$ always remains within a pair of the envelope curves, as shown in Figure 1-15. The time constant of these envelope curves is $1/\zeta\omega_n$

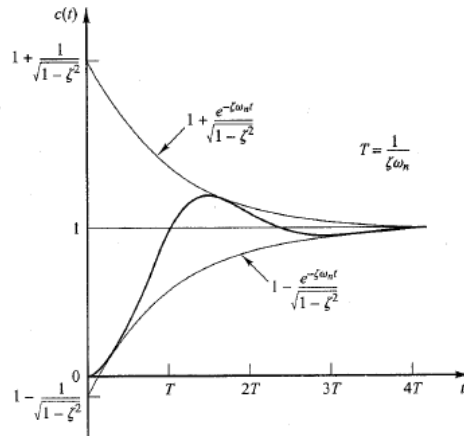

Figure 1-15 Pair of envelope curves for the unit step response curve of the system

Example 1.3

Consider the system shown in Figure (1-16), where $\zeta = 0.6$ and $\omega_n = 5$ rad/sec. Let us obtain the rise time t_r , peak time t_p , maximum overshoot M_p and settling time t_s when the system is subjected to a unit-step input. From the given values of ζ and ω_n

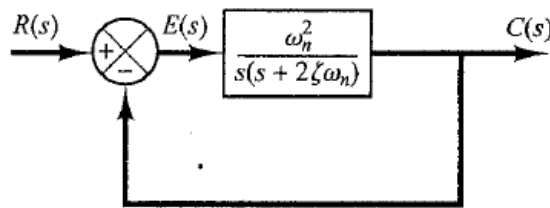

Figure 1-16 Second-order system.

We obtain $\omega_d = \omega_n \sqrt{1 - \zeta^2} = 4$ and $\sigma = \zeta\omega_n = 3$

Rise time t_r : The rise time is

$$t_r = \frac{\pi - \beta}{\omega_d} = \frac{3.14 - \beta}{4}$$

where β is given by

$$\beta = \tan^{-1} \frac{\omega_d}{\sigma} = \tan^{-1} \frac{4}{3} = 0.93 \text{ rad}$$

The rise time t_r is thus

$$t_r = \frac{\pi - \beta}{\omega_d} = \frac{3.14 - 0.93}{4} = 0.55 \text{ sec}$$

Peak time t_p : The peak time is

$$t_p = \frac{\pi}{\omega_d} = \frac{3.14}{4} = 0.785 \text{ sec}$$

Maximum overshoot M_p : The maximum overshoot is

$$M_p = e^{-(\sigma/\omega_d)\pi} = e^{-(3/4) \times 3.14} = 0.095$$

The maximum percent overshoot is thus 9.5%. Settling time t_s : For the 2% criterion, the settling time is

$$t_s = \frac{4}{\sigma} = \frac{4}{3} = 1.33 \text{ sec}$$

For the 5% criterion

$$t_s = \frac{3}{\sigma} = \frac{3}{3} = 1 \text{ sec}$$

1.12 Classification of Control Systems

Control systems may be classified according to their ability to follow step inputs, ramp inputs, parabolic inputs, and so on. This is a reasonable classification scheme because actual inputs may frequently be considered combinations of such inputs. The magnitudes of the steady-state errors due to these individual inputs are indicative of the goodness of the system. Consider the unity-feedback control system with the following open-loop Transfer function

$$G(s) = \frac{K(T_a s + 1)(T_b + 1) \dots (T_m + 1)}{s^N (T_1 s + 1)(T_2 + 1) \dots (T_p + 1)}$$

It involves the terms N in the denominator, representing a pole of multiplicity N at the origin. The present classification scheme is based on the number of integrations indicated by the open-loop transfer function. A system is called type 0, type 1, type 2, . . . , if $N = 0, N = 1, N = 2, \dots$, respectively. Note that this

classification is different from that of the order of a system. As the type number is increased, accuracy is improved; however, increasing the type number aggravates the stability problem. A compromise between steady-state accuracy and relative stability is always necessary. We shall see later that, if $G(s)$ is written so that each term in the numerator and denominator, except the terms N , approaches unity as s approaches zero, then the open loop gain K is directly related to the steady-state error.

1.13 Basic Concept of Controller:

PID Controllers

The PID controllers (P, PD, PI, PID) are very widely used, very well and successfully applied controllers to many applications, for many years, almost from the beginning of controls applications (D'Azzo & Houpis, 1988) (Franklin et al., 1994). (The facts of their successful application, good performance, easiness of tuning are speaking for themselves and are sufficient rational for their use, although their structure is justified by heuristics. These controls called proportional-integral-derivative (PID) control - constitute the heuristic approach to controller design that has found wide acceptance in the process industries (Franklin et al., 1994, pp. 168).

Classification of Controllers

The classification of controllers is based on the response of the controller and mode of operation of the controller. The controllers are basically classification as discontinuous controllers and continuous controllers.

Continuous controller modes

In the discontinuous controller mode the output of the controller is discontinuous and not smoothly varying. But in the continuous controller mode the controller output varies smoothly proportional to the error or proportional to some form of the error. Depending upon which form of the error is used as the input to the controller to produce the continuous controller output these controllers are classified as:

1. Proportional control mode
2. Integral control mode
3. Derivative control mode

A proportional-integral-derivative controller (PID controller) is a control loop feedback mechanism (controller) widely used in industrial control systems. PID controller calculates an error value as the difference between a measured process variable and a desired set point. The controller attempts to minimize the error, by adjusting the process through use of a manipulated variable. Many industrial processes are controlled using PID controllers. The popularity of PID controllers can be attributed partly to their good performance in a wide range of operating conditions and partly to their functional simplicity that allow. The error signal $e(t)$ is used to generate the proportional, integral, and derivative actions, with the resulting signals weighted and summed to form the control signal $u(t)$ applied to the plant model.

Table 1 Effect of Increasing the PID Gains K_P , K_D , and K_I , on the Step Response

PID Gain	Percent Overshoot	Settling Time	Steady-State Error
Increasing K_P	Increases	Minima	I impact
Increasing K_I	Increases	Increases	Decreases
Increasing K_D	Decreases	Decreases	Zero steady-state error No impact

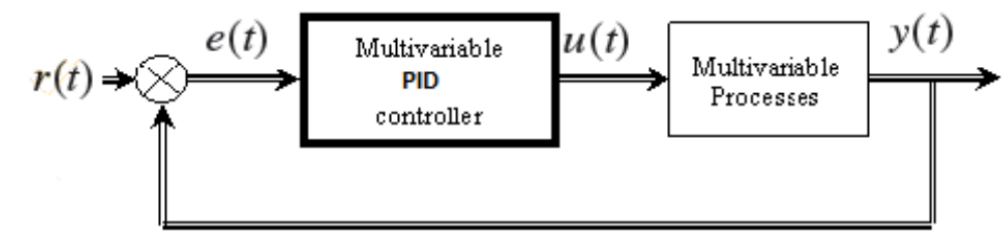

Figure 1-17A structure of a PID control system

Where $u(t)$ is the input signal to the multivariable processes, the error signal $e(t)$ is defined as $e(t) = r(t) - y(t)$, and $r(t)$ is the reference input signal. A standard PID controller structure is also known as the “three-term” controller.

This principle mode of action of the PID controller can be explained by the parallel connection of the P, I and D elements shown in Figure 1-18 Block diagram of the PID controller.

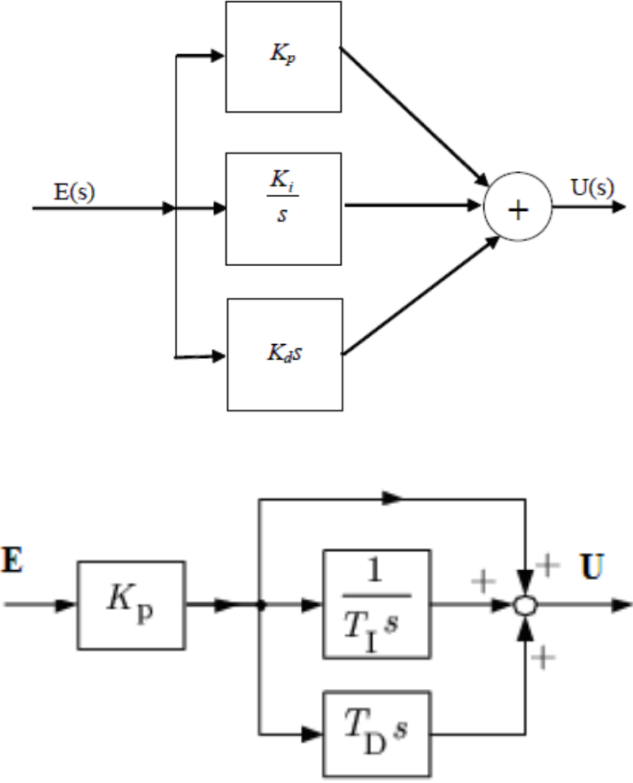

Figure 1-18 Parallel Form of the PID Compensator

These three variables K_p, T_I and T_D are usually tuned within given ranges. Therefore, they are often called the tuning parameters of the controller. By proper choice of these tuning parameters a controller can be adapted for a specific plant to obtain a good behavior of the controlled system. The time response of the controller output is

$$U(s) = K_P(e(t) + \frac{\int_0^t e(t)dt}{T_i} + T_d \frac{d e(t)}{d t})$$

Proportional Control Action

In this control the output of the controller is simple proportional to the error $e(t)$. the relation between the error $e(t)$ and the controller output p is determined by constant called proportional gain constant denoted as K_p . The output of the

controller is a linear function of the error $e(t)$, thus each value of the error has a unique value of the controller output. The range of the error which covers 0% to 100% controller output is called proportional band, The proportional band is the error (expressed in percentage of the range of the controlled variable) required to move the output of the controller from its lowest to its highest value.

Now though there exists linear relation between controller output and the error for a zero error the controller output should not be zero otherwise the process will come to halt. Hence there exists some controller output p_0 for the zero error. Hence mathematically the proportional control mode is expressed as:

$$p(t) = K_p e(t) + p_0$$

Where K_p = proportional gain constant

p_0 = controller output with zero error

The proportional band is mathematically defined by

$$PB = \frac{100}{K_p}$$

Integral Control Action

In a controller with integral control action, the value of the controller output $u(t)$ is changed at a rate proportional to the actuating error signal $e(t)$. That is

$$\frac{du(t)}{dt} = K_i e(t)$$

$$u(t) = K_i \int_0^t e(t) dt$$

Where K_i is an adjustable constant. The transfer function of the integral controller

$$\frac{U(s)}{E(s)} = \frac{K_i}{s}$$

Proportional-Plus-Integral Control Action (PI)

The control action of a proportional plus-integral controller is defined by

$$u(t) = K_p e(t) + \frac{K_p}{T_i} \int_0^t e(t) dt$$

or the transfer function of the controller is

$$\frac{U(s)}{E(s)} = K_p \left(1 + \frac{1}{T_i s} \right)$$

Where T_i is called the integral time

Proportional-Plus-Derivative Control Action (PD)

The control action of a proportional plus- derivative controller is defined by

$$u(t) = K_p e(t) + K_p T_d \frac{de(t)}{dt}$$

and the transfer function is

$$\frac{U(s)}{E(s)} = K_p (1 + T_d s)$$

where T_d is called the derivative time.

Proportional-Plus-Integral-Plus-Derivative Control Action (PID)

The combination of proportional control action, integral control action, and derivative control action is termed proportional-plus-integral-plus-derivative control action. It has the advantages of each of the three individual control actions. The equation of a controller with this combined action is given by

$$u(t) = K_p e(t) + \frac{K_p}{T_i} \int_0^t e(t) dt + K_p T_d \frac{de(t)}{dt}$$

The transfer function of the PID controller looks like the following:

$$\frac{U(s)}{E(s)} = K_p \left(1 + \frac{1}{T_i s} + T_d s \right)$$

Where K_p is the proportional gain, T_i the integral time, and T_d is the derivative time.

The transfer function of the PID controller is

$$G(s) = \frac{U(s)}{E(s)}$$

$$G(s) = K_p + \frac{K_I}{S} + K_D S = \frac{K_D S^2 + K_p S + K_I}{S}$$

PID pole Zero Cancellation

The PID equation can be written in this form:

$$G(s) = \frac{K_d \left(s^2 + \frac{K_P}{K_d} + \frac{K_i}{K_d} \right)}{s}$$

When this form is used it is easy to determine the closed loop transfer function.

$$H(s) = \frac{1}{s^2 + 2\zeta\omega_n + \omega_n^2}$$

$$\frac{K_i}{K_d} = \omega_n^2, \quad \frac{K_P}{K_d} = 2\zeta\omega_n$$

Then

$$G(s)H(s) = \frac{K_d}{s}$$

Chapter 2

Tuning Method for the Basic (PID) Control

2.1 Introduction

In this chapter we will study the tuning of feedback controllers—that is, the adjustment of the controller parameters to match the characteristics (or personality) of the rest of the components of the loop. We will look at two methods for characterizing the process dynamic characteristics: the on-line or closed-loop tuning method, and the step-testing or open-loop method. We will also look at three different specifications of control loop performance: quarter decay ratio response, minimum error integral, and controller synthesis. This latter method, in addition to providing some simple controller-tuning relationships, will give us some insight into the selection of the proportional, integral, and derivative modes for various process transfer functions. Tuning is the adjusting of the feedback controller parameters to obtain a specified closed-loop response. The tuning of a feedback control loop is analogous to the tuning of an automobile engine, a television set, or a stereo system. In each of these cases, the difficulty of the problem increases with the number of parameters that must be adjusted. For example, tuning a simple proportional-only or integral-only controller is similar to adjusting the volume of a stereo sound system. Because only one parameter or “knob” needs to be adjusted, the procedure consists of moving it in one direction or the other until the desired response (or volume) is obtained. The next degree of difficulty is the tuning of a two-mode or proportional-integral (PI) controller, which is similar to adjusting the bass and treble on a stereo system. Two parameters, the gain and the reset time, must be adjusted, so the tuning procedure is significantly more complicated than when only one parameter is involved. Finally, the tuning of three-mode or proportional integral-derivative (PID) controllers represents the next higher degree of difficulty. Here three parameters—the gain, the reset time, and the derivative time—must be adjusted. Although we have drawn an analogy between the tuning of a stereo system and that of a feedback control loop, we do not want to give the impression that the two tasks

have the same degree of difficulty. The main difference lies in the speed of response of the stereo system versus that of a process loop. With the stereo system, we get almost immediate feedback on the effect of our tuning adjustments. On the other hand, although some process loops do have relatively fast responses, for many process loops we may have to wait several minutes and maybe even hours to observe the response that results from our tuning adjustments. This makes tuning feedback controllers by trial and error a tedious and time-consuming task. Yet this is the method most commonly used by control and instrument engineers in industry. A number of procedures and formulas have been introduced to help enhance tuning effectiveness and give insight into tuning itself. We will study some of these procedures in this chapter. However, keep in mind that no one procedure will give the best results for all process control situations. The values of the tuning parameters depend on the desired closed-loop response and on the dynamic characteristics, or personality, of the other elements of the control loop, particularly the process. We saw that if the process is nonlinear, as is usually the case, then its characteristics change from one operating point to the next. This means that a particular set of tuning parameters can produce the desired response at only one operating point, given that standard feedback controllers are basically linear devices. For operation in a range of operating conditions, a compromise must be reached in arriving at an acceptable set of tuning parameters, because the response will be sluggish at one end of the range and oscillatory at the other. One characteristic of feedback control that greatly simplifies the tuning procedure is that the performance of the loop is not a strong function of the tuning parameters. In other words, the performance does not vary much with the tuning parameters. Changes of less than 50% in the values of the tuning parameters seldom have significant effects on the response of the loop. Accordingly, we will not show the values of the tuning parameters with more than two significant digits. With this in mind, let us look at some of the procedures that have been proposed for tuning industrial controllers.

There are many tuning methods, but most common methods are as follows:

1- Manual Tuning Method

2- Ziegler-Nichols Tuning Method

3- Cohen-Coon Tuning Method

4- PID Tuning Software Methods (ex. MATLAB)

One form of controller widely used in industrial process control is the three-terms. This controller has a transfer function

$$G_c(s) = K_P + \frac{K_I}{s} + K_D s \quad (2 - 1)$$

The equation for the output in the time domain is

$$u(t) = K_P e(t) + K_I \int e(t) dt + K_D \frac{de(t)}{dt} \quad (2 - 2)$$

The three-term controller is called a PID controller because it contains a proportional, an integral, and a derivative term represented by K_p , K_i and K_d respectively. The transfer function of the derivative term is actually

$$G_d(s) = \frac{K_D s}{\tau_d s + 1} \quad (2 - 3)$$

But τ_d is usually much smaller than the time constants of the process itself, so it is neglected. If we set $K_D = 0$, then we have the proportional plus integral (PI) controller

$$G_c(s) = K_P + \frac{K_I}{s} \quad (2 - 4)$$

When $K_I=0$, we have

$$G_c(s) = K_P + K_D s$$

Which is called a proportional plus derivative (PD) controller

The PID controller can also be viewed as a cascade of the PI and the PD controllers. Consider the PI controller

$$G_{PI}(s) = K'_P + \frac{K'_I}{s}$$

and the PD controller

$$G_{PD}(s) = K_P^- + K_D^- s$$

where K_P' and K_I' are the PI controller gains and K_P^- and K_D^- are the PD controller gains. Cascading the two controllers (that is, placing them in series) yields

$$\begin{aligned} G_c(s) &= G_{PI}(s)G_{PD}(s) \\ &= \left(K_P' + \frac{K_I'}{s}\right)(K_P^- + K_D^- s) \\ &= (K_P^- K_P' + K_P' K_D^-) + K_P' K_D^- s + \frac{K_P' K_D^-}{s} \\ &= K_P + K_D(s) + \frac{K_I}{s} \end{aligned}$$

Where we have the following relationships between the PI and PD controller gains and the PID controller gains

$$\begin{aligned} K_P &= K_P^- K_P' + K_I' K_D^- \\ K_D &= K_P' K_D^- \\ K_I &= K_P' K_D^- \end{aligned}$$

Consider the PID controller

$$\begin{aligned} G_c(s) &= K_P + \frac{K_I}{s} + K_D s = \frac{K_D s^2 + K_P s + K_I}{s} & (2-5) \\ \frac{K_D(s^2 + as + b)}{s} &= \frac{K_D(s + z_1)(s + z_2)}{s} \end{aligned}$$

Where $a = K_P/K_D$ and $b = K_I/K_D$. Therefore PID controller introduces a transfer function with one pole at the origin and two zeros that can be located anywhere in the s -plane.

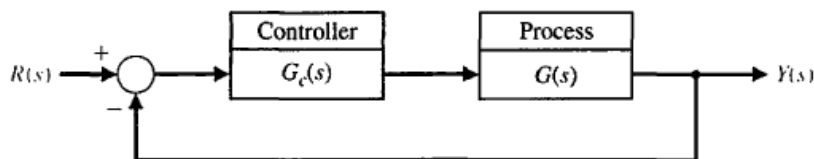

Figure 2-1 Closed-loop system with a controller

One approach to manual tuning is to first set $K_I = 0$ and $K_D = 0$. This is followed by slowly increasing the gain K_P until the output of the closed-loop system oscillates just on the edge of instability. This can be done either in simulation or on the actual system if it cannot be taken off-line.

2.2 Stability

In this section, a qualitative property of control systems—namely, stability—will be introduced. The concept of stability is very important because every control system must be stable. If a control system is not stable, it will usually bum out or disintegrate. There are three types of stability, bounded-input bounded-output (BIBO) stability, marginal stability (or stability in the sense of ROUTH and Root LOCUS), and asymptotic stability.

Routh's Stability Criterion

The most important problem in linear control systems concerns stability. That is, under the conditions will a system become unstable, If it is unstable, how should we stabilize the system. In this it was stated that a control system is stable if and only if all closed-loop poles lie in the left-half s plane. Most linear closed-loop systems have closed-loop transfer functions of the form

$$\frac{C(s)}{R(s)} = \frac{b_0s^m + b_1s^{m-1} + \dots + b_{m-1}s + b_m}{a_0s^n + a_1s^{n-1} + \dots + a_{n-1}s + b_0} = \frac{A(s)}{B(s)} \quad (2 - 6)$$

Where the a's and b's are constants and $m \leq n$. A simple criterion, known as Routh's stability criterion, enables us to determine the number of closed-loop poles that lie in the right-half s plane without having to factor the denominator polynomial. (The polynomial may include parameters that MATLAB cannot handle.)

2.3 Routh's Stability Criterion

Routh's stability criterion tells us whether or not there are unstable roots in a polynomial equation without actually solving for them. This stability criterion applies to polynomials with only a finite number of terms. When the criterion is applied to a control system, information about absolute stability can be obtained directly from the coefficients of the characteristic equation.

The procedure in Routh's stability criterion is as follows

1- Write the polynomial in s in the following form:

$$a_n s^n + a_{n-1} s^{n-1} + \dots + a_1 s + a_0 = 0 \quad (2 - 7)$$

Where the coefficients are real quantities, we assume that $a \neq 0$; that is, any zero root has been removed.

2- If any of the coefficients are zero or negative in the presence of at least one positive coefficient, there is a root or roots that are imaginary or that have positive real parts. Therefore, in such a case, the system is not stable. If we are interested in only the absolute stability, there is no need to follow the procedure further. Note that all the coefficients must be positive. This is a necessary condition, as may be seen from the following argument: A polynomial in s having real coefficients can always be factored into linear and quadratic factors, such as $(s + a)$ and $s^2 + bs + c$ where a , b , and c are real. The linear factors yield real roots and the quadratic factors yield complex-conjugate roots of the polynomial. The factor $s^2 + bs + c$ yields roots having negative real parts only if b and c are both positive. For all roots to have negative real parts, the constants a , b , c , and so on, in all factors must be positive. The product of any number of linear and quadratic factors containing only positive coefficients always yields a polynomial with positive coefficients. It is important to note that the condition that all the coefficients be positive is not sufficient to assure stability. The necessary but not sufficient condition for stability is that the coefficients of Equation (2-7) all be present and all have a positive sign. (If all a 's are negative, they can be made positive by multiplying both sides of the equation by -1 .)

1- If all coefficients are positive, arrange the coefficients of the polynomial in rows and columns according to the following pattern:

$$\begin{array}{rcccccc}
 S^n & a_0 & a_2 & a_4 & a_6 & \dots \\
 S^{n-1} & a_1 & a_3 & a_5 & a_7 & \dots \\
 S^{n-2} & b_1 & b_2 & b_3 & b_4 & \dots \\
 S^{n-3} & c_1 & c_2 & c_3 & c_4 & \dots \\
 S^{n-3} & & d_1 & d_2 & d_3 & d_4 & \dots
 \end{array}$$

$$\begin{array}{ccc}
& : & : \\
& : & : \\
S^2 & e_1 & e_2 \\
S^1 & f_1 & \\
S^0 & g_1 &
\end{array}$$

The process of forming rows continues until we run out of elements. (The total number of rows is $(n + 1)$). The coefficients $b_1, b_2, b_3,$ and so on, are evaluated as follows

$$b_1 = \frac{a_1 a_2 - a_0 a_3}{a_1}$$

$$b_2 = \frac{a_1 a_4 - a_0 a_5}{a_1}$$

$$b_3 = \frac{a_1 a_6 - a_0 a_7}{a_1}$$

$$c_1 = \frac{b_1 a_3 - a_1 b_2}{b_1}$$

$$c_2 = \frac{b_1 a_5 - a_1 b_3}{b_1}$$

$$c_3 = \frac{b_1 a_7 - a_1 b_4}{b_1}$$

:

$$d_1 = \frac{c_1 b_2 - b_1 c_2}{c_1}$$

$$d_2 = \frac{c_1 b_3 - b_1 c_3}{c_1}$$

This process is continued until the n th row has been completed. The complete array of coefficients is triangular. Note that in developing the array an entire row may be divided or multiplied by a positive number in order to simplify the subsequent numerical calculation without altering the stability conclusion.

Routh's stability criterion states that the number of roots of Equation (2-7) with positive real parts is equal to the number of changes in sign of the coefficients of the first column of the array. It should be noted that the exact values of the terms

in the first column need not be known; instead, only the signs are needed. The necessary and sufficient condition that all roots of Equation (2-7) lie in the left-half s plane is that all the coefficients of Equation (2-7) be positive and all terms in the first column of the array have positive signs.

Example 2-1

Let us apply Routh's stability criterion to the following third-order polynomial:

$$a_0s^3 + a_1s^2 + a_2s + a_3 = 0 \quad (2-8)$$

where all the coefficients are positive numbers. The array of coefficients becomes

$$\begin{array}{r} s^3 \quad a_0 \quad a_2 \\ s^2 \quad a_1 \quad a_3 \\ s^1 \quad \frac{a_1a_2 - a_0a_3}{a_1} \\ s^0 \quad a_3 \end{array}$$

The condition that all roots have negative real parts is given by

$$a_1a_2 > a_0a_3$$

Example 2-2

Consider the following polynomial

$$s^4 + 2s^3 + 3s^2 + 4s + 5 = 0 \quad (2-9)$$

Let us follow the procedure just presented and construct the array of coefficients.

(The first two rows can be obtained directly from the given polynomial.

The remaining terms are obtained from these. If any coefficients are missing, they may be replaced by zeros in the array.)

$$\begin{array}{r} s^4 \quad 1 \quad 3 \quad 5 \\ s^3 \quad 2 \quad 4 \quad 0 \\ s^2 \quad 1 \quad 5 \\ s^1 \quad -6 \\ s^0 \quad 5 \end{array}$$

In this example, the number of changes in sign of the coefficients in the first column is 2. This means that there are two roots with positive real parts. Note that

the result is unchanged when the coefficients of any row are multiplied or divided by a positive number in order to simplify the computation.

Special Cases If a first-column term in any row is zero, but the remaining terms are not zero or there is no remaining term, then the zero term is replaced by a very small positive number ϵ and the rest of the array is evaluated.

Example 2-3

Consider the following equation:

$$s^3 + 2s^2 + s + 2 = 0 \tag{2 - 10}$$

The array of coefficients is

$$\begin{array}{r} s^3 \quad 1 \quad 1 \\ s^2 \quad 2 \quad 2 \\ s^1 \quad 0 \approx \epsilon \\ s^0 \quad 2 \end{array}$$

If the sign of the coefficient above the zero (ϵ) is the same as that below it, it indicates that there are a pair of imaginary roots. Actually, equation (2-10) has two roots at $s = \mp i$. If, however, the sign of the coefficient above the zero (ϵ) is opposite that below it, it indicates that there is one sign change. For example, for the equation

$$s^3 - 3s + 2 = (s - 1)^2(s + 2) = 0 \tag{2 - 11}$$

the array of coefficients is

$$\begin{array}{r} s^3 \quad 1 \quad -3 \\ s^2 \quad 0 = \epsilon \quad 2 \\ s^1 \quad -3 - \frac{2}{\epsilon} \\ s^0 \quad 2 \end{array}$$

Example 2-4

Consider the following equation

$$s^5 - 2s^4 + 24s^3 + 48s^2 - 25s - 50 = 0 \tag{2 - 12}$$

$$\begin{array}{r} s^5 \quad 1 \quad 24 \quad -25 \\ s^4 \quad 2 \quad 48 \quad -50 \end{array}$$

$$s^3 \quad 0 \quad 0$$

The terms in the s^3 row are all zero. (Note that such a case occurs only in an odd numbered row.) The auxiliary polynomial is then formed from the coefficients of the s^4 row. The auxiliary polynomial $P(s)$ is

$$P(s) = 2s^4 + 48s^2 - 50$$

which indicates that there are two pairs of roots of equal magnitude and opposite sign (that is, two real roots with the same magnitude but opposite signs or two complex conjugate roots on the imaginary axis). These pairs are obtained by solving the auxiliary polynomial equation $P(s) = 0$. The derivative of $P(s)$ with respect to s is

$$\frac{dp(s)}{ds} = 8s^3 + 96s$$

The terms in the s^3 row are replaced by the coefficients of the last equation, that is, 8 and 96. The array of coefficients then becomes

$$\begin{array}{rcccc} s^5 & 1 & 24 & -25 \\ s^4 & 2 & 48 & -50 \\ s^3 & 8 & 96 & \\ s^2 & 24 & -50 & \\ s^1 & 112.7 & 0 & \\ s^0 & -50 & & \end{array}$$

We see that there is one change in sign in the first column of the new array. Thus, the original equation has one root with a positive real part. By solving for roots of the auxiliary polynomial equation, we obtain

$$\begin{aligned} 2s^4 + 48s^2 - 50 &= 0 \\ s^2 = 1, \quad s^2 &= -25 \\ s = \pm 1, \quad s &= \pm 5i \end{aligned}$$

These two pairs of roots of $P(s)$ are a part of the roots of the original equation. As a matter of fact, the original equation can be written in factored form as follows:

$$(s + 1)(s - 1)(s + 5j)(s - 5j)(s + 2) = 0$$

Clearly, the original equation has one root with a positive real part.

Example 2-5

Consider the system shown in Figure 2-2. Let us determine the range of K for stability. The closed-loop transfer function is

$$\frac{C(s)}{R(s)} = \frac{K}{s(s^2 + 5 + 1)(s + 2) + K} \quad (2 - 13)$$

The characteristic equation is

$$s^4 + 3s^3 + 3s^2 + 2s + K = 0$$

The array of coefficients becomes

s^4	1	3	K
s^3	3	2	0
s^2	$\frac{7}{3}$	K	
s^1	$2 - \frac{9}{7}K$		
s^0	K		

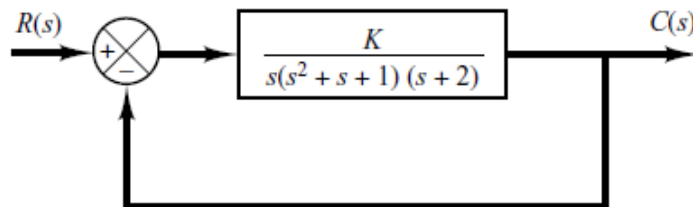

Figure 2-2 Control system

For stability, K must be positive, and all coefficients in the first column must be positive. Therefore,

$$\frac{14}{9} > K > 0$$

When $K = 14/9$ the system becomes oscillatory and, mathematically, the oscillation is sustained at constant amplitude. Note that the ranges of design parameters that lead to stability may be determined by use of Routh's stability criterion.

2.4 Ziegler- Nichols Tuning for PID Controller

The ideas we discuss here are the result of an empirical investigation by Ziegler-Nichols [1942]. We give two methods for specifying PID parameters. The first will be applicable quite often, especially for BIBO stable plants, whereas the second makes some assumptions about the nature of the system. Ziegler and Nichols developed two techniques for controller tuning in the 1940s. The idea was to tune the controller based on the following idea: Make a simple tuning, extract some features of process dynamics to determine controller parameters from the features. One method is based on direct adjustment of the controller parameters and Nichols is based on determination of the open loop step response of the process. Such rules suggest a set of values of K_p , K_i and K_d that will give a stable operation of the system. However, the resulting system may exhibit a large maximum overshoot in the step response, which is unacceptable. In such a case we need series of fine tunings until an acceptable result is obtained. In fact, the Ziegler–Nichols tuning rules give an educated guess for the parameter values and provide a starting point for fine tuning, rather than giving the final settings for and in a single shot. Ziegler and Nichols proposed rules for determining values of the proportional gain K_p , integral time T_i and derivative time T_d based on the transient response characteristics of a given plant. Such determination of the parameters of PID controllers or tuning of PID controllers can be made by engineers on-site by experiments on the plant. There are two methods called Ziegler–Nichols tuning rules: the first method and the second method.

First Method (open loop)

In the first method, we obtain experimentally the response of the plant to a unit-step input, as shown in Figure 2–2. If the plant involves neither integrator(s) nor dominant complex-conjugate poles,

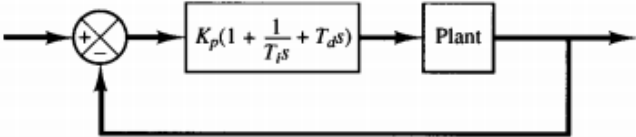

Figure 2-3 PID control of a plant

This method applies if the response to a step input exhibits an S-shaped curve. Such step-response curves may be generated experimentally or from a dynamic simulation of the plant. The S-shaped curve may be characterized by two constants, delay time L and time constant T . The delay time and time constant are determined by drawing a tangent line at the inflection point of the S-shaped curve and determining the intersections of the tangent line with the time axis and line $c(t) = K$



Figure 2-4 Unit – step response of plant

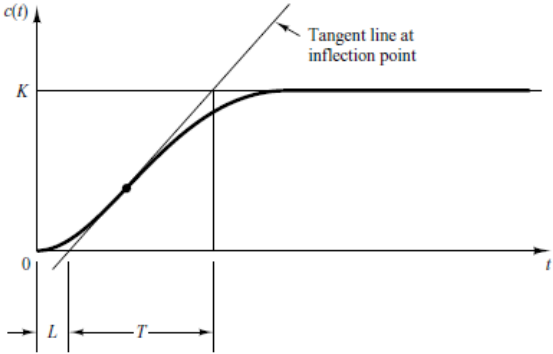

Figure 2-5 S-shaped response curve

Ziegler–Nichols tuning rule based on step response of plant (first method)

Type of controller	K_p	T_i	T_d
P	$\frac{T}{L}$	∞	0
PI	$0.9 \frac{T}{L}$	$\frac{L}{0.3}$	0
PID	$1.2 \frac{T}{L}$	$2L$	$0.5L$

The transfer function $C(s)/U(s)$ may then be approximated by a first-order system with a transport Lag as follows

$$\frac{C(s)}{U(s)} = \frac{Ke^{-Ls}}{Ts+1}$$

Ziegler and Nichols suggested to set the values of K_p , T_i and T_d according to the formula shown in Table above. Notice that the PID controller tuned by the first method of Ziegler–Nichols rules gives

$$\begin{aligned} G_c(s) &= K_p \left(1 + \frac{1}{T_i s} + T_d s \right) \\ &= 1.2 \frac{T}{L} \left(1 + \frac{1}{2Ls} + 0.5Ls \right) \\ &= 0.6T \frac{\left(s + \frac{1}{L} \right)^2}{s} \end{aligned}$$

Thus, the PID controller has a pole at the origin and double zeros at $s = -1/L$.

Second Method (close loop)

In the second method, we first set $T_i = \infty$ and $T_d = 0$.Using the proportional control action only, increase K_p from 0 to a critical value K_{cr} at which the output first exhibits sustained oscillations. Thus, the critical gain K_{cr} and corresponding period P_{cr} . Ziegler and Nichols suggested that we set the values of the parameters K_p , T_i , and T_d according to the formula shown in Table -1

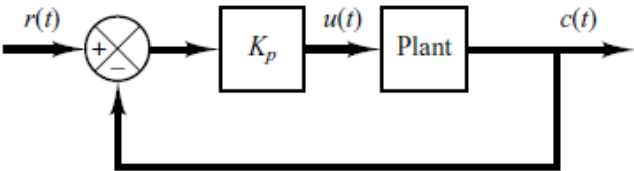

Figure 2-6 closed loop system with a proportional controlled

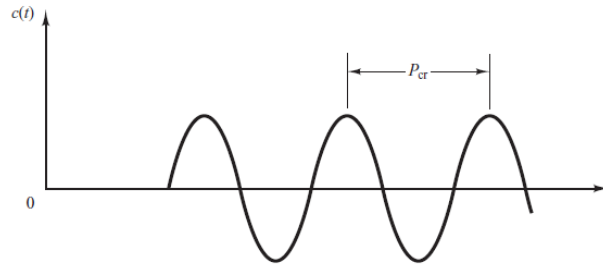

Figure 2-7 Sustained oscillation with period P_{cr}

Table-1 Ziegler-Nichols Tuning Rule Based on Critical Gain K_{cr} , and Critical Period P_{cr}

Type of controller	K_p	T_i	T_d
P	$0.5K_{cr}$	∞	0
PI	$0.45 K_{cr}$	$\frac{1}{1.2} P_{cr}$	0
PID	$0.6K_{cr}$	$0.5 P_{cr}$	$0.125P_{cr}$

Notice that the PID controller tuned by the second method of Ziegler–Nichols rules gives

$$\begin{aligned}
 G_C(s) &= K_p \left(1 + \frac{1}{T_i s} + T_d s \right) & (2-14) \\
 &= 0.6K_{cr} \left(1 + \frac{1}{0.5P_{cr}s} + 0.125P_{cr}s \right) \\
 &= 0.075K_{cr}P_{cr} \frac{\left(s + \frac{4}{P_{cr}} \right)^2}{s}
 \end{aligned}$$

Thus, the PID controller has a pole at the origin and double zeros at $s = -4/P_{cr}$. Note that if the system has a known mathematical model (such as the transfer function), then we can use the root-locus method to find the critical gain K_{cr} and the frequency of the sustained oscillations ω_{cr} , where $2\pi/\omega_{cr} = P_{cr}$. These values can be found from the crossing points of the root-locus branches with the $i\omega$ axis.

Example 2-6

Consider the control system shown in figure 2-7 in which a PID controller is used to control the system. The PID controller has the transfer function

$$G_c(s) = K_p \left[1 + \frac{1}{T_i s} + T_d s \right] \quad (2 - 15)$$

Although many analytical methods are available for the design of a PID controller for the present system, let us apply a Ziegler–Nichols tuning rule for the determination of the values of parameters K_p , T_i , and T_d . Then obtain a unit-step response curve and check to see if the designed system exhibits approximately 25% maximum overshoot. If the maximum overshoot is excessive (40% or more), make a fine tuning and reduce the amount of the maximum overshoot to approximately 25% or less. Since the plant has an integrator, we use the second method of Ziegler–Nichols tuning rules. By setting $T_i = \infty$ and $T_d = 0$ we obtain the closed-loop transfer function as follows

$$\frac{C(s)}{R(s)} = \frac{K_p}{s(s+1)(s+5)K_p} \quad (2 - 16)$$

The value of K_p that makes the system marginally stable so that sustained oscillation occurs can be obtained by use of Routh's stability criterion. Since the characteristic equation for the closed-loop system is

$$s^3 + 6s^2 + 5s + K_p$$

The Routh array becomes as follow

$$\begin{array}{ccc} s^3 & 1 & 5 \\ s^2 & 6 & K_p \\ s^1 & \frac{30 - K_p}{6} & \\ s^0 & K_p & \end{array}$$

Examining the coefficients of the first column of the Routh table, we find that sustained oscillation will occur if $K_{cr} = 30$. Thus, the critical gain K_{cr} is

$$K_{cr} = 30$$

With gain K, set equal to $K_{cr} = 30$, the characteristic equation becomes

$$s^3 + 6s^2 + 5s + 30 = 0$$

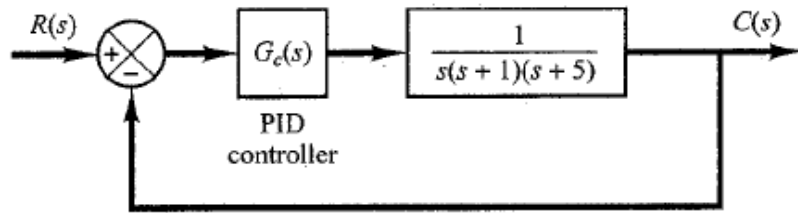

Figure 2-8 PID controller system

To find the frequency of the sustained oscillation, we substitute $s = i\omega$ into this characteristic equation as follows:

$$(i\omega)^3 + 6(i\omega)^2 + 5(i\omega) + 30 = 0$$

$$6(5 - \omega^2) + i\omega(5 - \omega^2) = 0$$

from which we find the frequency of the sustained oscillation to be $\omega^2 = 5$ or $\omega = \sqrt{5}$. Hence, the period of sustained oscillation is

$$P_{cr} = \frac{2\pi}{\omega} = \frac{2\pi}{\sqrt{5}} = 2.8099$$

Referring to Table 2-2, we determine K_p , T_i and T_d as follows

$$K_p = 0.6K_{cr} = 18$$

$$T_i = 0.5P_{cr} = 1.405$$

$$T_d = 0.125P_{cr} = 0.35124$$

The transfer function of the PID controller is thus

$$\begin{aligned} G_c(s) &= K_p \left(1 + \frac{1}{T_i s} + T_d s \right) \\ &= 18 \left(1 + \frac{1}{1.405s} + 0.35124s \right) \\ &= \frac{6.3223(s + 1.4235)^2}{s} \end{aligned}$$

The PID controller has a pole at the origin and double zero at $s = -1.4235$. A block diagram of the control system with the designed PID controller is shown in

Figure 2-9. Next, let us examine the unit-step response of the system. The closed-loop transfer function $C(s)/R(s)$ is given

$$\frac{6.3223s^2 + 18s + 12.811}{s^4 + 6s^3 + 11.3223s^2 + 18s + 12.811}$$

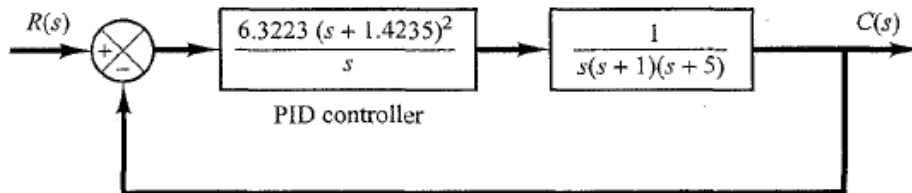

Figure 2- 9The system with PID controller

It can be reduced by fine tuning the controller parameters. Such fine tuning can be made on the computer. We find that by keeping $K_p = 18$ and by moving the double zero of the PID controller to $s = -0.65$, that is, using the PID controller

$$G_c(s) = 18 \left(1 + \frac{1}{3.77s} + 0.7692s \right) = 13.846 \frac{(s + 0.65)^2}{s}$$

Example 2.7

the rang of measured variable for a certain control system is 2 mV to12 mV and a setpoint of 7mv. Find the error as percent of span when the measured variable is 6.5 mv

Solution : $b_{\max} = 12 \text{ mv}$, $b_{\min} = 2 \text{ mv}$, $b = 6.5 \text{ mv}$, $r = 7 \text{ mv}$

$$e_p = \frac{r - b}{b_{\max} - b_{\min}} \times 100 = \frac{7 - 6.5}{12 - 2} \times 100 = 5\%$$

2-5 PID Tuning Gains Toolbox In MATLAB

The PID control scheme is named after its three correcting terms, whose sum constitutes the manipulated variable (MV).The proportional, integral and derivative terms are summed to calculate the output of the PID controller. Defining $u(t)$ as the controller output, Controller manufacturers arrange the Proportional, Integral and Derivative modes into three different controller

algorithms or controller structures. These are called Interactive, Non interactive and parallel algorithms. Some controller manufacturers allow you to choose between different controller algorithms as a configuration option in the controller software. PID tuning is the process of finding the values of proportional, integral, and derivative gains of a PID controller to achieve desired performance and meet design requirements. PID controller tuning appears easy, but finding the set of gains that ensures the best performance of your control system is a complex task. PID controllers are tuned either manually or using rule based method. tuning Manual methods are iterative and time-consuming, and if used on hardware, they can cause damage. Rule-based methods also have serious limitations ,they do not support certain types of plant models, such as unstable plants, high-order plants, or plants with little or no time delay. You can automatically tune PID controllers to achieve the optimal system design and to meet design requirements, even for plant models that traditional rule-based methods cannot handle well. An automated PID tuning work flow involves:

- 1- Identifying plant model from input-output test data
- 2- Modeling PID controllers in MATLAB using PID objects or in Simulink using PID Controller blocks
- 3- Automatically tuning PID controller gains and fine-tune your design interactively.
- 4- Tuning multiple controllers in batch mode
- 5- Tuning single-input single-output PID controllers

PID Tuning Toolbox

Can be use the PID tuning toolbox to determine the parameter of controller depend on the system form MATLAB or Simulink as following step MATLAB. Use the PID Tuner to interactively design a SISO PID controller in the feed-forward path of single-loop, unity-feedback control configuration.

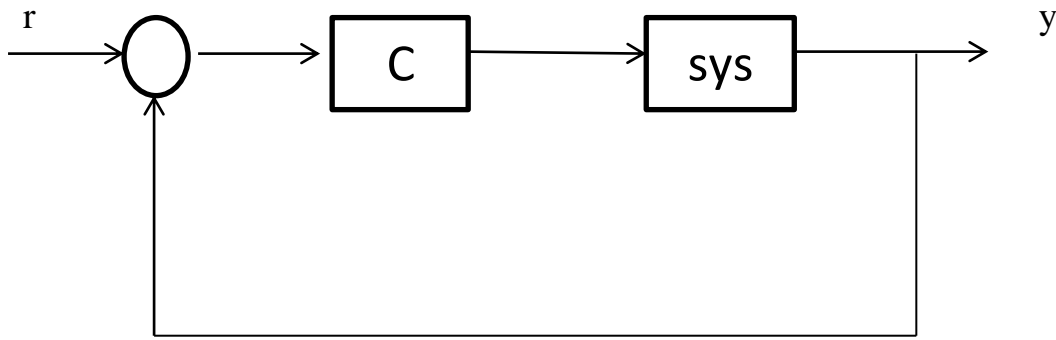
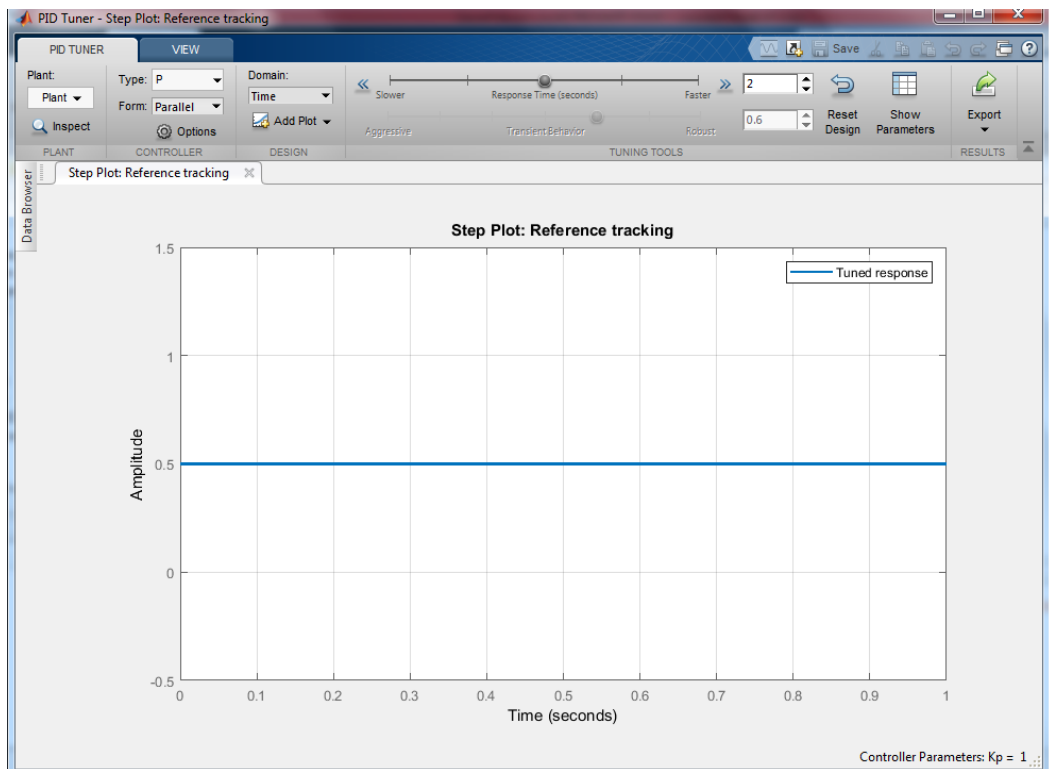

Figure 2-10 The PID control

The PID Tuner automatically designs a controller for your plant. You specify the controller type (P, I, PI, PD, PDF, PID, PIDF) and form (parallel or standard). You can analyze the design using a variety of response plots, and interactively adjust the design to meet your performance requirements. To launch the PID Tuner, use the pid Tuner command: PID Tuner (sys, type) where sys is a linear model of the plant you want to control type is a string indicating the controller type to design.



PID Controller Type

The PID Tuner can tune up to seven types of controllers. To select the controller type, use one of these methods. Provide the type argument to the launch command pid Tuner. In PID Tuner, use the Type menu to change controller types.

Simulink

Select the PID controller block form Simulink Library.

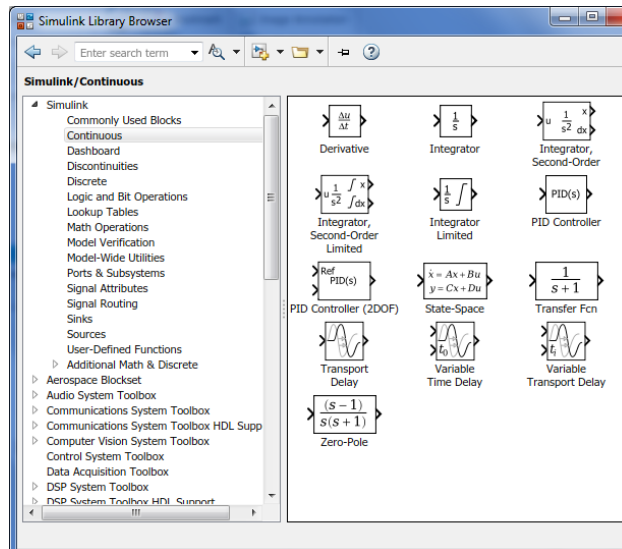

Drag the PID controller and place in the Simulink model, and double click on block.

Example 2-8

This example shows how to use the PID tuner to design a controller for the plant

$$G = \frac{1}{(S + 1)^3} \quad (2 - 17)$$

Create the plant model and open the PID Tuner to design a PI controller for a first pass design.

```

>> G = zpk([], [-1 -1 -1], 1);
>> G

G =

    1
    ----
   (s+1)^3

Continuous-time zero/pole/gain model.

>> pid Tuner (G)

```

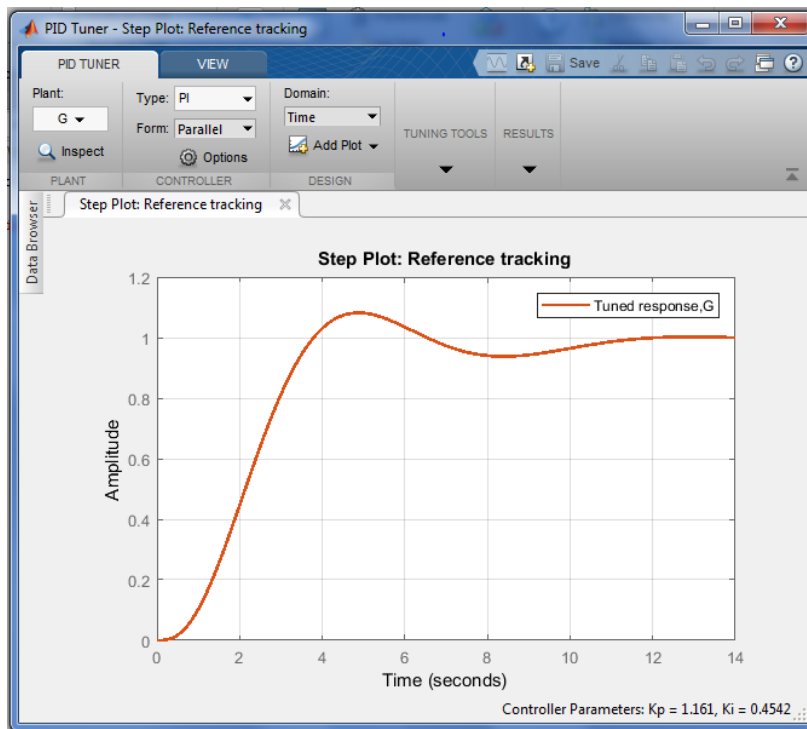

The PID Tuner toolbox

Examine the reference tracking rise time and settling time. Right-click on the plot and select Characteristics > Rise Time to mark the rise time as a blue dot on the plot. Select Characteristics > Settling Time to mark the settling time. To see tooltips with numerical values, click each of the blue dots.

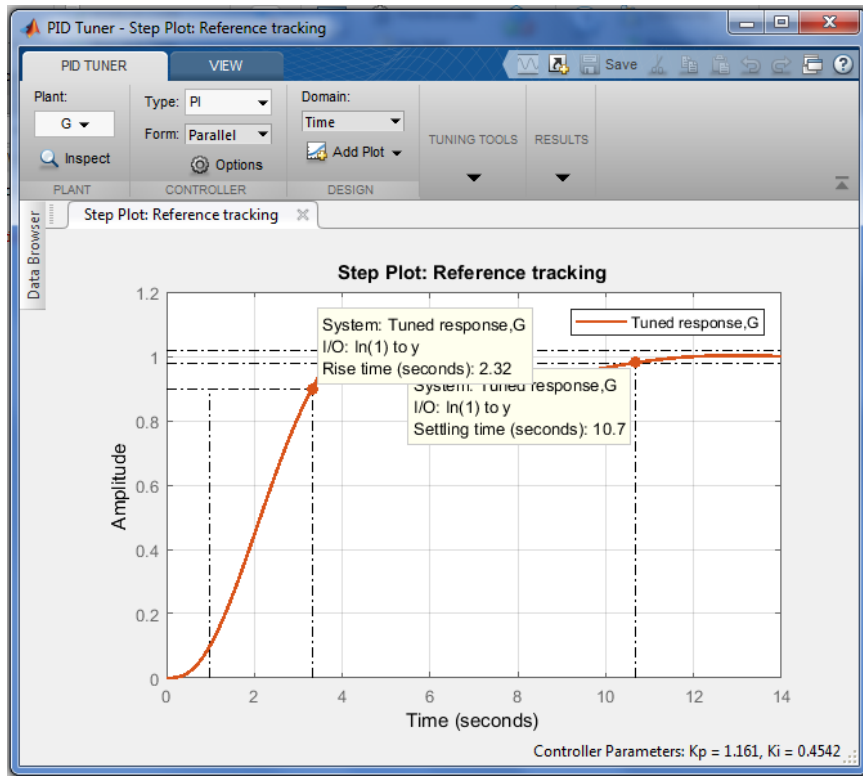

Slide the Response time slider to the right to try to improve the loop performance. The response plot automatically updates with the new design.

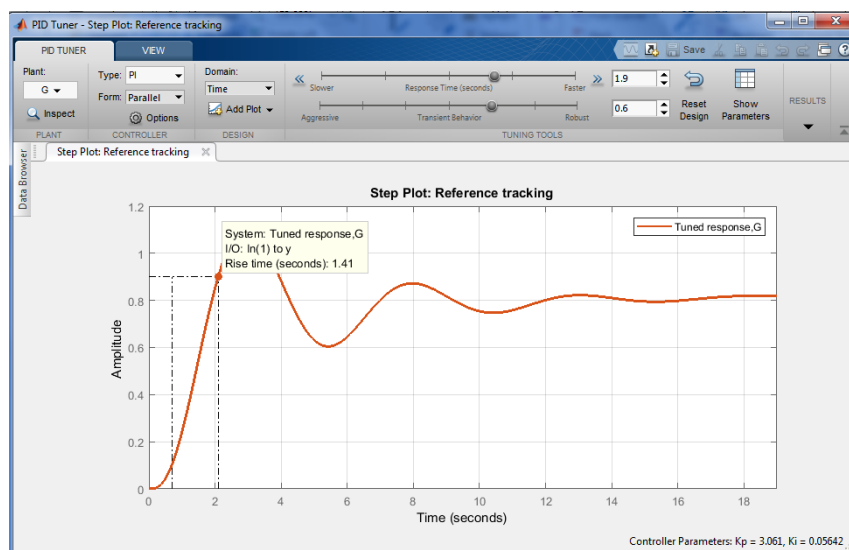

Moving the response time slider far enough to meet the rise time requirement of less than 1.5 s results in more oscillation. Additionally, the parameters display shows that the new response has an unacceptably long settling time.

Controller Parameters	
	Tuned
Kp	3.0615
Ki	0.056416
Kd	n/a
Tf	n/a

Performance and Robustness	
	Tuned
Rise time	1.41 seconds
Settling time	177 seconds
Overshoot	10.6 %
Peak	1.11
Gain margin	8.18 dB @ 1.72 rad/s
Phase margin	39.6 deg @ 1.05 rad/s
Closed-loop stability	Stable

To achieve the faster response speed, the algorithm must sacrifice stability. Change the controller type to improve the response. Adding derivative action to the controller gives the PID Tuner more freedom to achieve adequate phase margin with the desired response speed. In the Type menu, select PIDF. The PID Tuner designs a new PIDF controller.

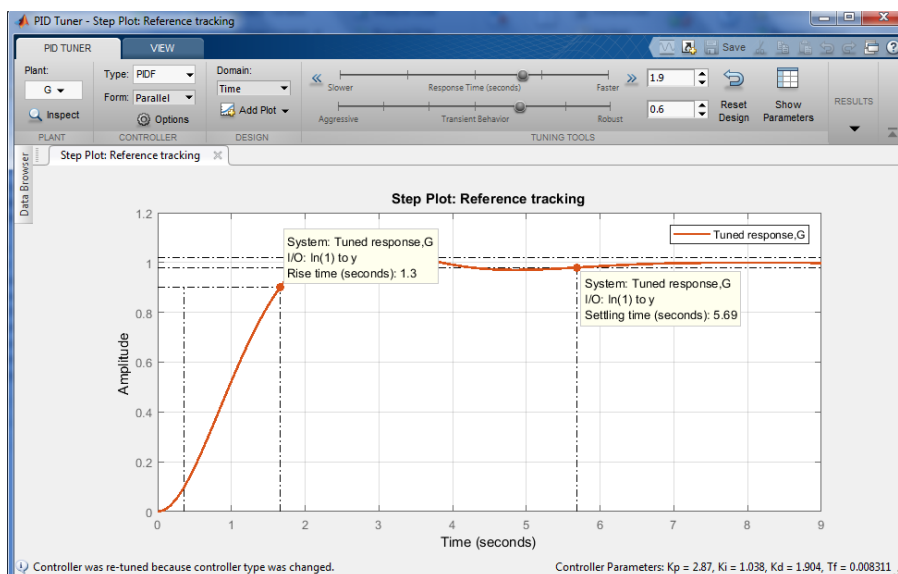

The rise time and settling time now meet the design requirements. You can use the Response time slider to make further adjustments to the response .To revert to the default automated tuning result, click Reset Design.

Analyze other system responses

To analyze other system responses, click Add Plot. Select the system response you want to Analyze.

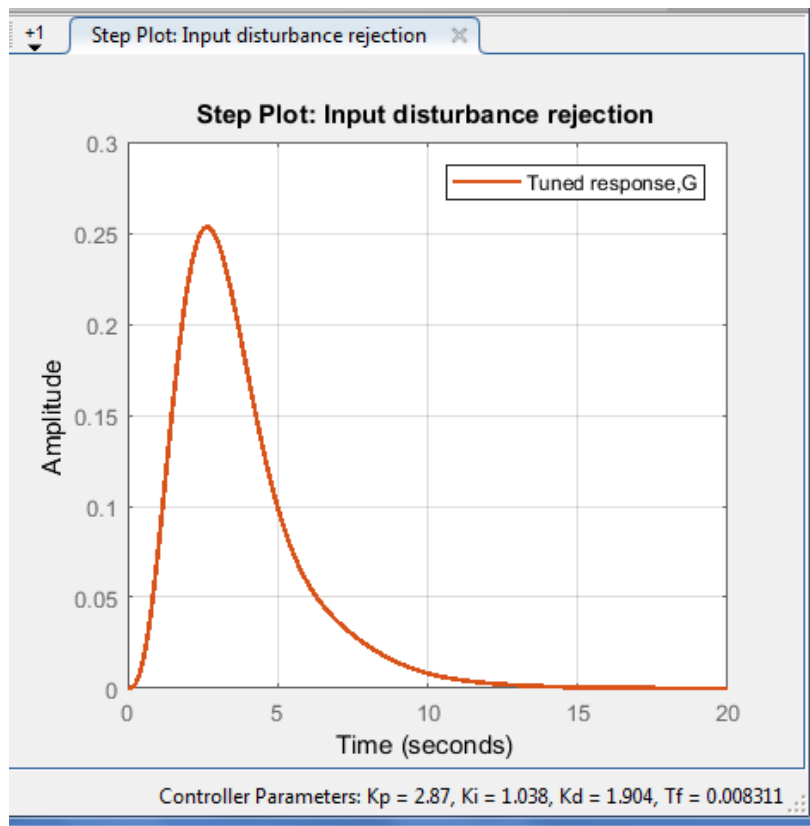

Example 2-9

Using MATLAB to find the parameter of PID controller and step response of the system

$$G(s) = \frac{1}{2s^2 + 10s + 1} \quad (2 - 18)$$

MATLAB Program

```
% .....pid example ....  
num=[1]  
den=[2 10 1]
```

```

Wp=
tf(num,den,'iodelay',2)
Kp=1;
Ki=0;
Kd=0;
Wc=pid(Kp,Ki,Kd)

H=[1]
Yc= feedback(Wp*Wc,H)
Step(Yc) , grid on
Ki=0
Kd=0
Wc =pid(Kp,Ki,Kd)
Mc=feedback(Gc*Gp, H)
Step(Wc)
grid on

```

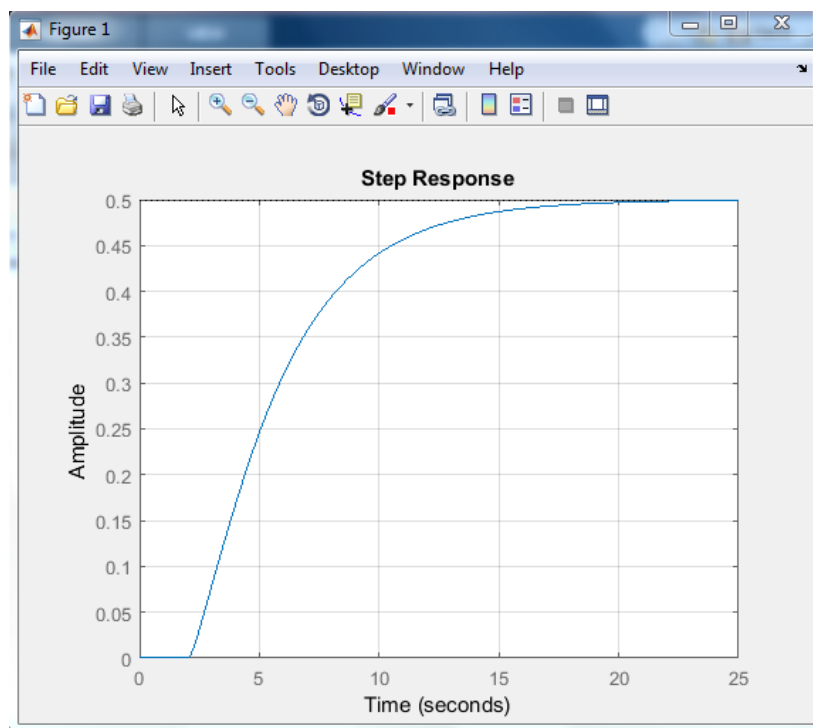

```

Kp=6;
Ki=1
Kd=1

```

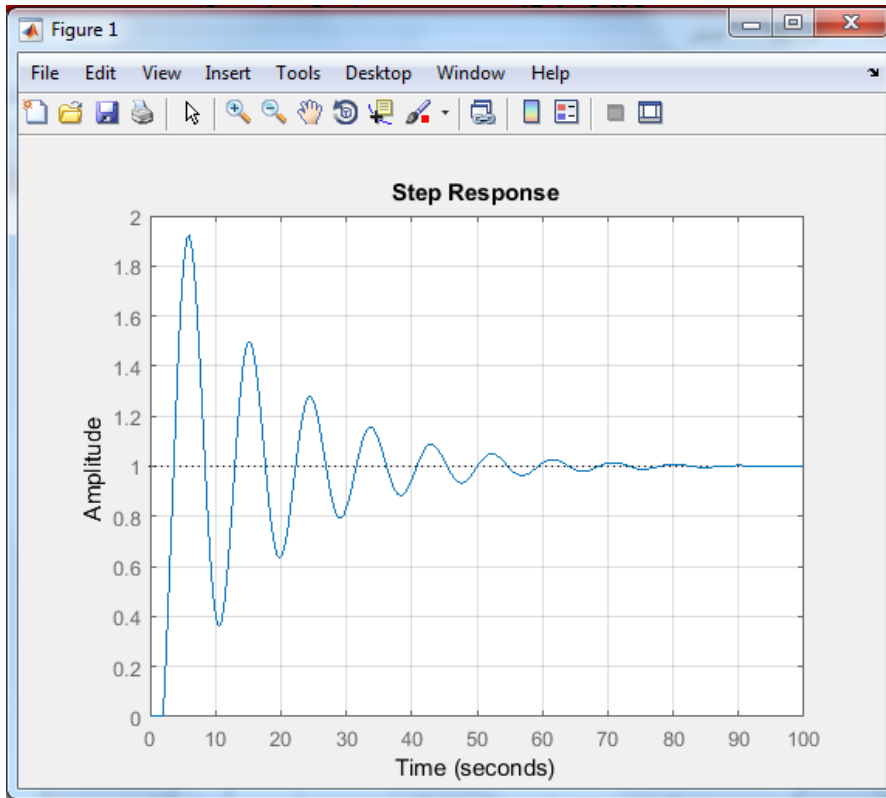

$K_d = 4$

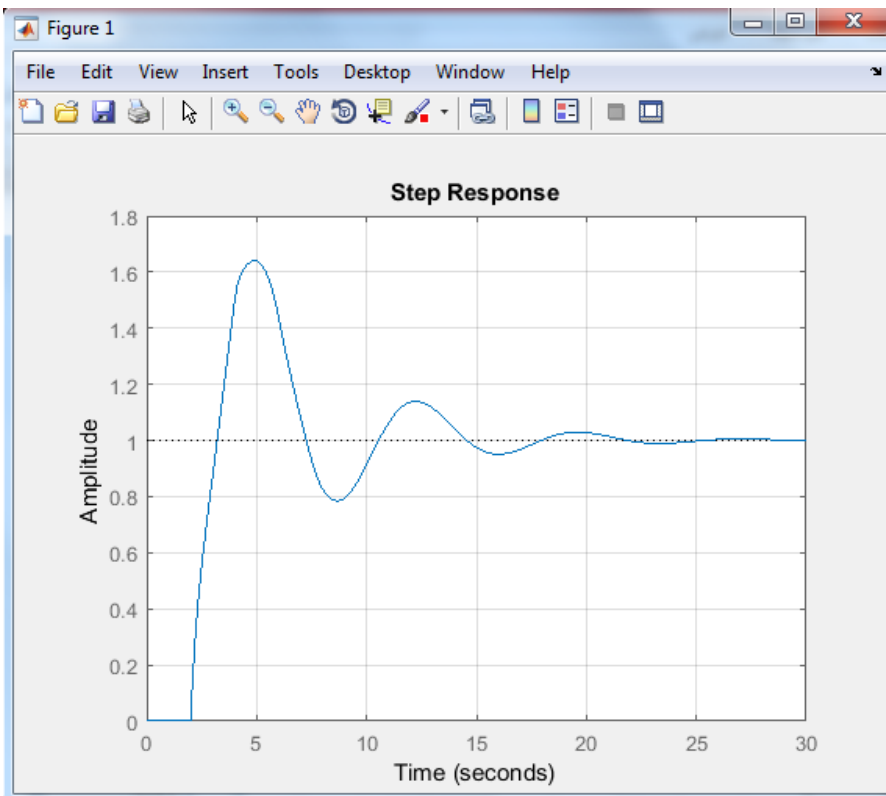

Simulink

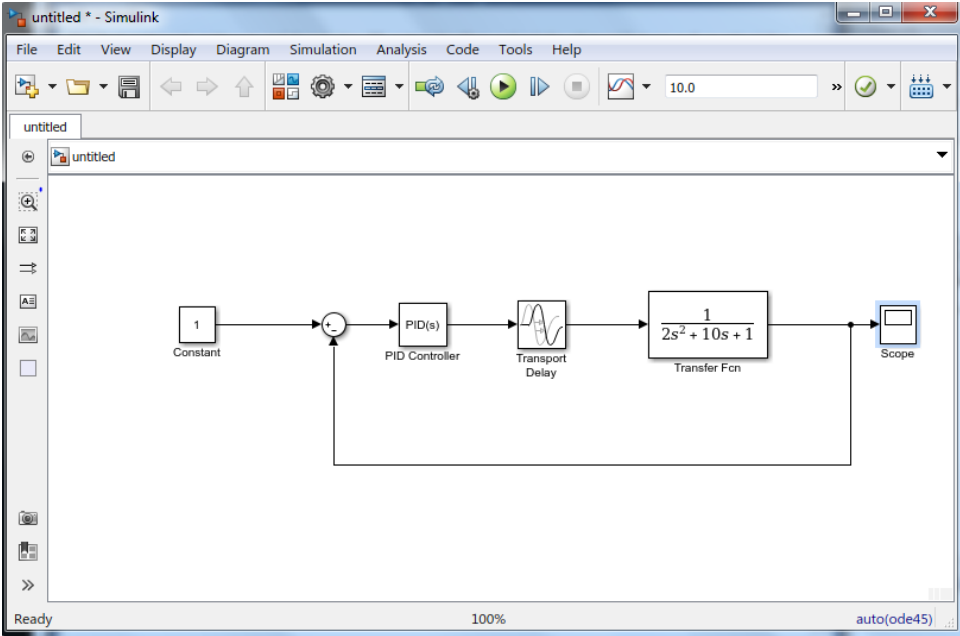

Block Parameters: PID Controller

Time domain:
 Continuous-time
 Discrete-time

Main | PID Advanced | Data Types | State Attributes

Controller parameters

Source: [Compensator formula](#)

Proportional (P):

Integral (I):

Derivative (D):

Filter coefficient (N):

$$P + I \frac{1}{s} + D \frac{N}{1 + N \frac{1}{s}}$$

Initial conditions

Source:

Integrator:

Filter:

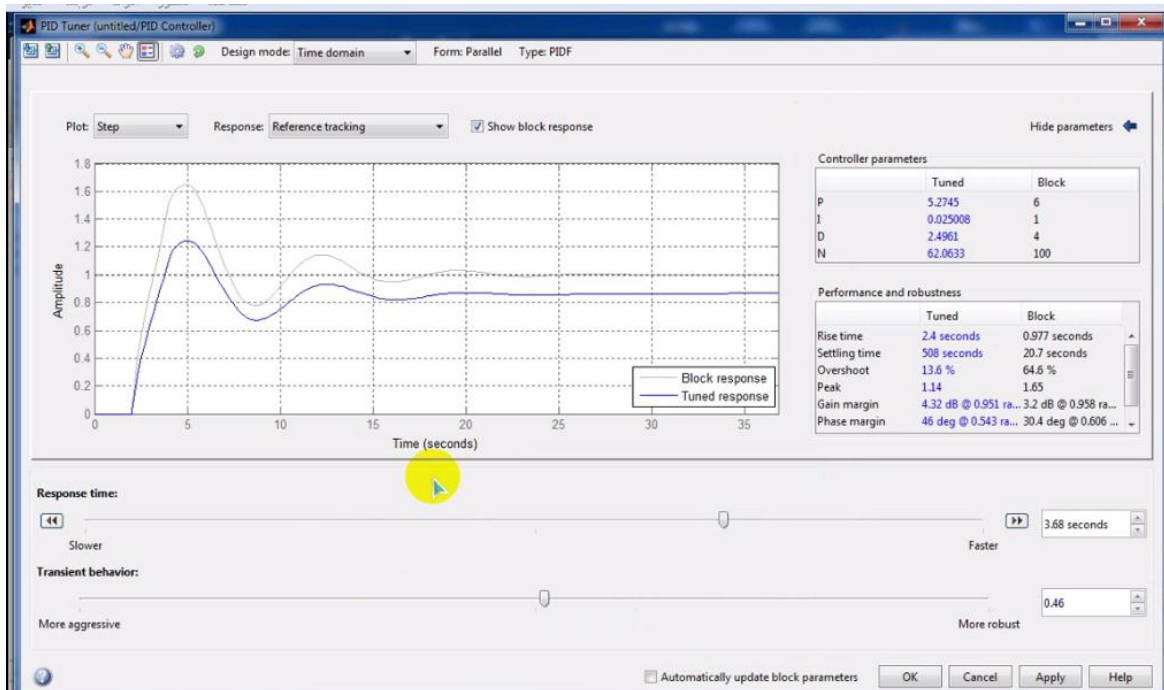

Example 2-10

Obtain the unit-impulse response of the following system:

$$\frac{C(s)}{R(s)} = G(s) = \frac{1}{s^2 + 0.2s + 1} \quad (2 - 19)$$

MATLAB Program will produce the unit-impulse response. The resulting plot is shown in Figure blew then use pid controller

MATLAB Program

```
% .....pid example ....
num=[0 0 1];
den=[1 0.2 1];
Gp=tf (num,den)
H=[1]
M=feedback(Gp, H)
impulse(num, den);
grid on
hold on
title('Unit-Impulse Response of G(s) =
1/(s^2 + 0.2s + 1)')
% .... PID parameter .....
Kp=1
Ki=0
Kd=0
Gc=pid(Kp,Ki,Kd)
Mc=feedback(Gc*Gp, H)
Step(Mc)
grid on
```

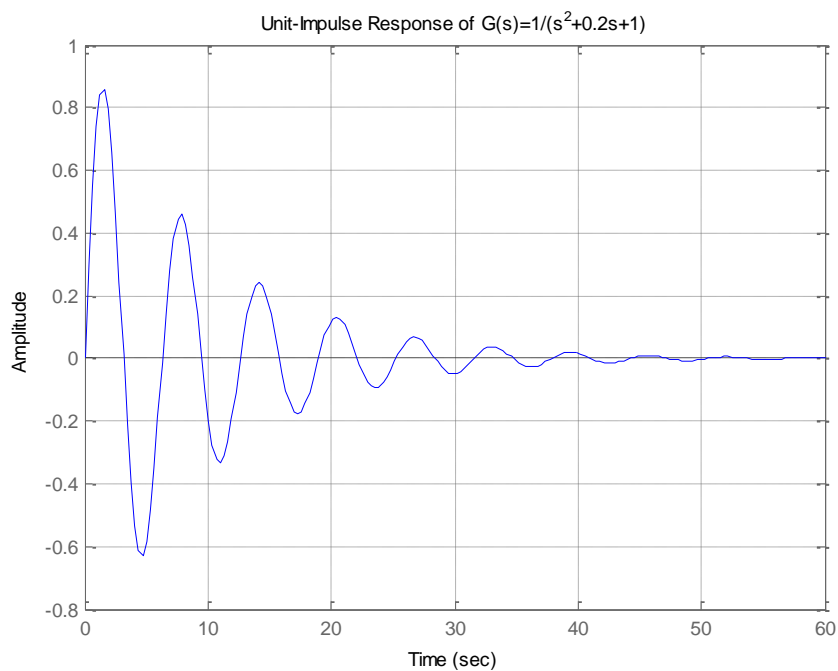
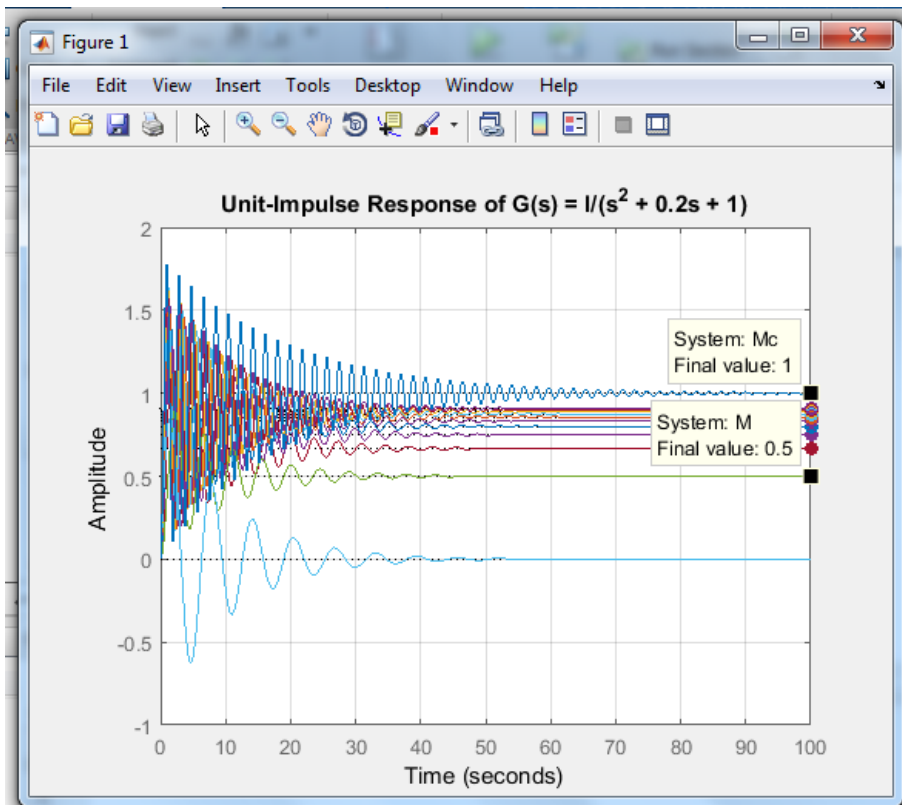
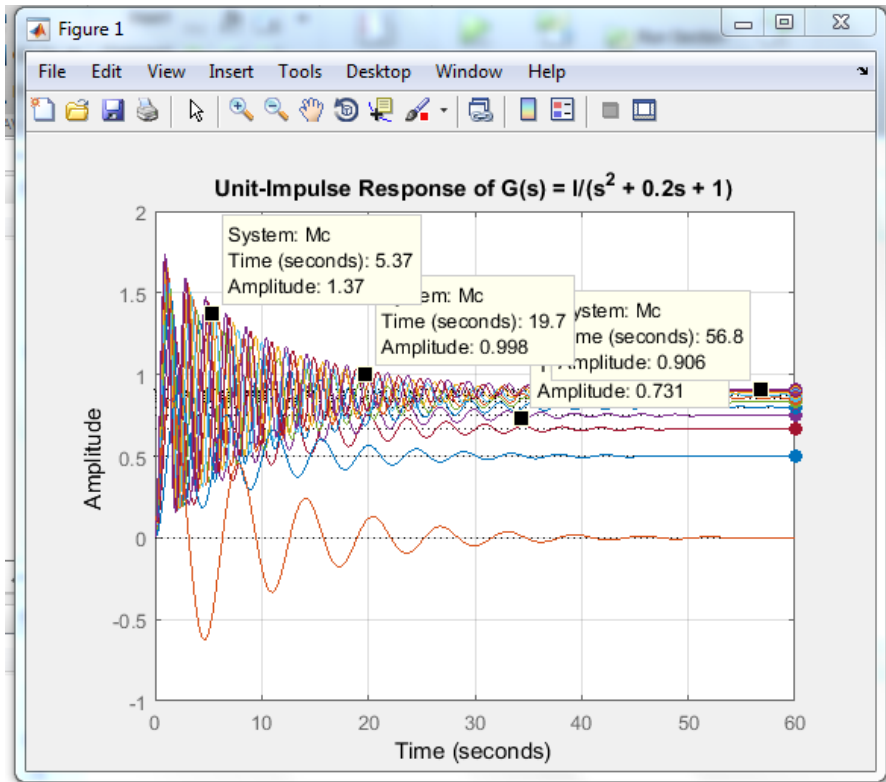

Figure 2-11 Unit-impulse response curve



Chapter 3

Discussion of Computational Approach for Transient -Response Analysis with MATLAB

3.1 Introduction

The practical procedure for plotting time response curves of systems higher than second-order is through computer simulation; in this chapter we present the computational approach for the transient-response analysis with MATLAB. In particular, we discuss step response, impulse response, ramp response, and responses to other simple inputs.

3.2 MATLAB Representation of Linear Systems

The transfer function of a system is represented by two arrays of numbers.

Consider the system

$$\frac{C(s)}{R(s)} = \frac{2s + 25}{s^2 + 4s + 25} \quad (3 - 1)$$

This system can be represented as two arrays, each containing the coefficients of the polynomials in decreasing powers of s as follows

$$\text{num} = [2 \ 25]$$

$$\text{den} = [1 \ 4 \ 25]$$

An alternative representation is

$$\text{num} = [0 \ 2 \ 25]$$

$$\text{den} = [1 \ 4 \ 25]$$

In this expression a zero is padded. Note that if zeros are padded, the dimensions of "num" vector and "den" vector become the same. An advantage of padding zeros is that the "num" vector and "den" vector can be directly added. For example,

$$\begin{aligned} \text{num} + \text{den} &= [0 \ 2 \ 25] + [1 \ 4 \ 25] \\ &= [1 \ 6 \ 50] \end{aligned}$$

If num and den (the numerator and denominator of the closed-loop transfer function) are known, commands such as

$$\text{step}(\text{num}, \text{den}), \quad \text{step}(\text{num}, \text{den}, t)$$

will generate plots of unit-step responses. For a control system defined in a state-space form, where state matrix **A**, control matrix **B**, output matrix **C**, and direct transmission matrix **D** of state-space equations are known, the command

$$\text{step}(\mathbf{A}, \mathbf{B}, \mathbf{C}, \mathbf{D})$$

will generate plots of unit-step responses. The time vector is automatically determined when t is not explicitly included in the step commands. Note that the command `step(sys)` may be used to obtain the unit-step response of a system. First, define the system by

$$\text{sys} = \text{tf}(\text{num}, \text{den})$$

$$\text{or } \text{sys} = \text{ss}(\mathbf{A}, \mathbf{B}, \mathbf{C}, \mathbf{D})$$

Then, to obtain, the unit-step response, enter

$$\text{step}(\text{sys})$$

Into the computer,

when step commands have left-hand arguments such as

$$[y, x, t] = \text{step}(\text{num}, \text{den})$$

$$[y, x, t] = \text{step}(\mathbf{A}, \mathbf{B}, \mathbf{C}, \mathbf{D}, iu)$$

$$[y, x, t] = \text{step}(\mathbf{A}, \mathbf{B}, \mathbf{C}, \mathbf{D}, iut) \quad (3 - 2)$$

Hence it is necessary to use a plot command to see the response curves. The matrices y and x contain the output and state response of the system, respectively, evaluated at the computation time points t. Note in Equation () that the scalar iu is an index into the inputs of the system and specifies which input is to be used for the response, and t is the user-specified time. If the system involves multiple inputs and multiple outputs, the step command, such as given by Equation (), produces a series of step response

$$x = Ax + Bu$$

$$y = Cx + Du$$

Example 3 -1

Consider the following system

$$\begin{bmatrix} \dot{x}_1 \\ \dot{x}_2 \end{bmatrix} = \begin{bmatrix} -1 & -1 \\ 6.5 & 0 \end{bmatrix} \begin{bmatrix} x_1 \\ x_2 \end{bmatrix} + \begin{bmatrix} 1 & 1 \\ 1 & 0 \end{bmatrix} \begin{bmatrix} u_1 \\ u_2 \end{bmatrix}$$
$$\begin{bmatrix} y_1 \\ y_2 \end{bmatrix} = \begin{bmatrix} 1 & 0 \\ 0 & 1 \end{bmatrix} \begin{bmatrix} x_1 \\ x_2 \end{bmatrix} + \begin{bmatrix} 0 & 0 \\ 0 & 0 \end{bmatrix} \begin{bmatrix} u_1 \\ u_2 \end{bmatrix}$$

Obtain the unit-step response curves.

Although it is not necessary to obtain the transfer matrix expression for the system to obtain the unit-step response curves with MATLAB, we shall derive such an expression for reference. For the system defined by

$$\dot{x} = Ax + Bu$$

$$y = Cx + Du$$

The transfer matrix $G(s)$ is a matrix that relates $Y(s)$ and $U(s)$ as follows

$$Y(s) = G(s)U(s)$$

Taking Laplace transforms of the state-space equations, we obtain

$$sX(s) - x(0) = AX(s) + BU(s) \quad (3-3)$$

$$Y(s) = CX(s) + DU(s) \quad (3-4)$$

In deriving the transfer matrix, we assume that $x(0) = 0$. Then, from Equation (3-3), we get

$$X(s) = (sI - A)^{-1}BU(s) \quad (3-5)$$

Substituting Equation (3-5) into Equation (3-4), we obtain

$$Y(s) = C[(sI - A)^{-1}B + D]U(s)$$

Thus the transfer matrix $G(s)$ is given by

$$G(s) = C(sI - A)^{-1}B + D$$

The transfer matrix $G(s)$ for the given system becomes

$$\begin{aligned} G(s) &= C(sI - A)^{-1}B \\ &= \begin{bmatrix} 1 & 0 \\ 0 & 1 \end{bmatrix} \begin{bmatrix} s+1 & 1 \\ -6.5 & s \end{bmatrix}^{-1} \begin{bmatrix} 1 & 1 \\ 1 & 0 \end{bmatrix} \\ &= \frac{1}{s^2 + s + 6.5} \begin{bmatrix} s & -1 \\ 6.5 & s+1 \end{bmatrix} \begin{bmatrix} 1 & 1 \\ 1 & 0 \end{bmatrix} \end{aligned}$$

$$= \frac{1}{s^2 + s + 6.5} \begin{bmatrix} s - 1 & s \\ s + 7.5 & 6.5 \end{bmatrix} \begin{bmatrix} 1 & 1 \\ 1 & 0 \end{bmatrix}$$

Hence

$$\begin{bmatrix} Y_1 \\ Y_2 \end{bmatrix} = \begin{bmatrix} \frac{s - 1}{s^2 + s + 6.5} & \frac{s}{s^2 + s + 6.5} \\ \frac{s + 7.5}{s^2 + s + 6.5} & \frac{6.5}{s^2 + s + 6.5} \end{bmatrix}$$

Since this system involves two inputs and two outputs, four transfer functions may be defined depending on which signals are considered as input and output. Note that, when considering the signal u_1 as the input, we assume that signal u_2 is zero, and vice versa. The four transfer functions are

$$\frac{Y_1}{U_1} = \frac{s - 1}{s^2 + s + 6.5}$$

$$\frac{Y_2}{U_1} = \frac{s + 7.5}{s^2 + s + 6.5}$$

$$\frac{Y_1}{U_2} = \frac{s}{s^2 + s + 6.5}$$

$$\frac{Y_2}{U_2} = \frac{6.5}{s^2 + s + 6.5}$$

The four individual step-response curves can be plotted by use of the command step (A,B,C,D), MATLAB Program 3-1 produces four such step-response curves. The curves are shown in Figure 3-1.

MATLP Program
A=[-1 -1;6.5 0];
B=[1 1;1 0];
C=[1 0 ;0 1];
D=0 0;0 0];
Step (A,B,C,D)

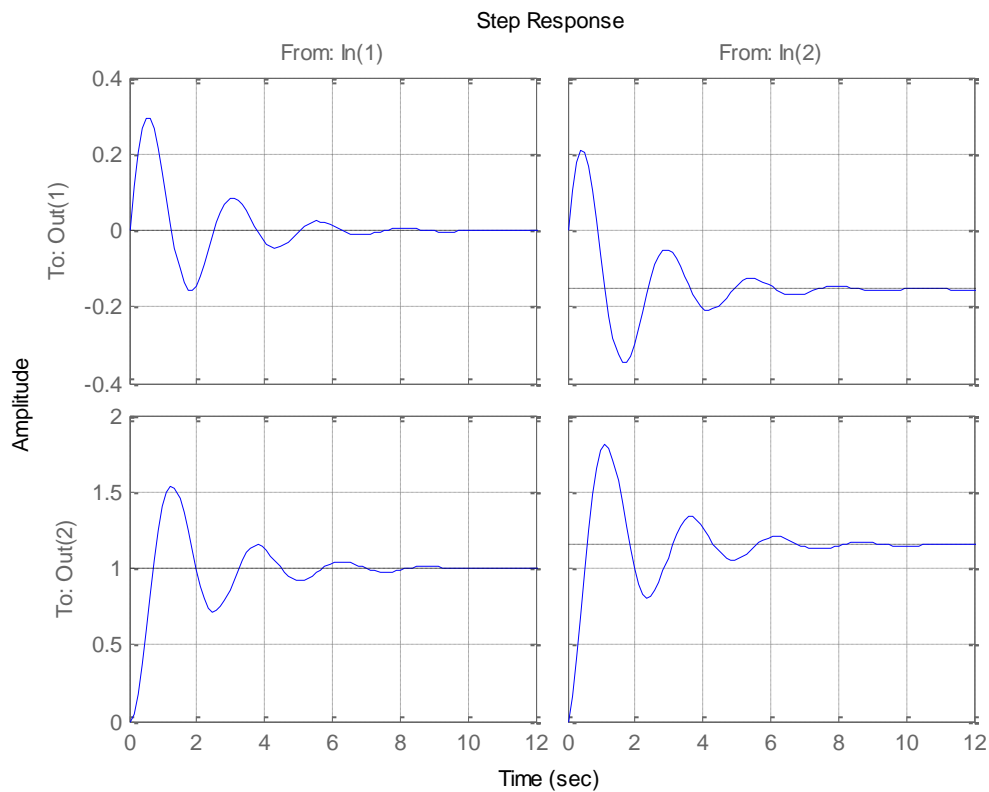

Figure3-1 unit step response curves

3.3 MATLAB Description of Standard Second-Order System

As noted earlier, the second-order system

$$G(s) = \frac{\omega_n^2}{s^2 + 2\zeta\omega_n s + \omega_n^2} \quad (3 - 6)$$

is called the standard second-order system. Given ω_n and ζ , the command prints num/den as a ratio of polynomials in s .

Consider, for example, the case where $\omega_n = 5$ rad/sec and $\zeta = 0.4$. MATLAB Program3-2 generates the standard second-order system where $\omega_n = 5$ rad/sec and $\zeta = 0.4$

MATLAB Program
<pre> wn = 5; damping_ratio = 0.4; [num,den]=ord2(wn,damping_ratio); num = 5^2*num0; printsys(num,den,'s') num/den = $\frac{25}{s^2+4s+25}$ </pre>

The Unit-Step Response of the Transfer-Function System

Let us consider the unit-step response of the system given by

$$G(s) = \frac{1}{s^2 + 4s + 25}$$

MATLAB Program will yield a plot of the unit-step response of this system. A plot of the unit-step response curve is shown in Figure 3-2. Notice in Figure 3-2 that the x axis and y axis labels are automatically determined. If it is desired to label the x axis and y axis differently, we need to modify the step command. For example, if it is desired to label the x axis as 't Sec' and the y axis as 'Input and Output,' then use step-response commands with left-hand arguments, such as

$$c = \text{step}(\text{num}, \text{den}, t)$$

or, more generally,

$$[y, x, t] = \text{step}(\text{num}, \text{den}, t)$$

MATLAB Program

```
%- - - - - Unit-step response -----  
% ***** Enter the numerator and denominator of the transfer  
% function *****  
num = [0 0 25];  
den = [1 4 25];  
% ***** Enter the following step-response command *****  
step(num,den)  
%***** Enter grid and title of the plot *****  
grid  
title (' Unit-Step Response of G(s) = 25/(s^2+4s+25)')
```

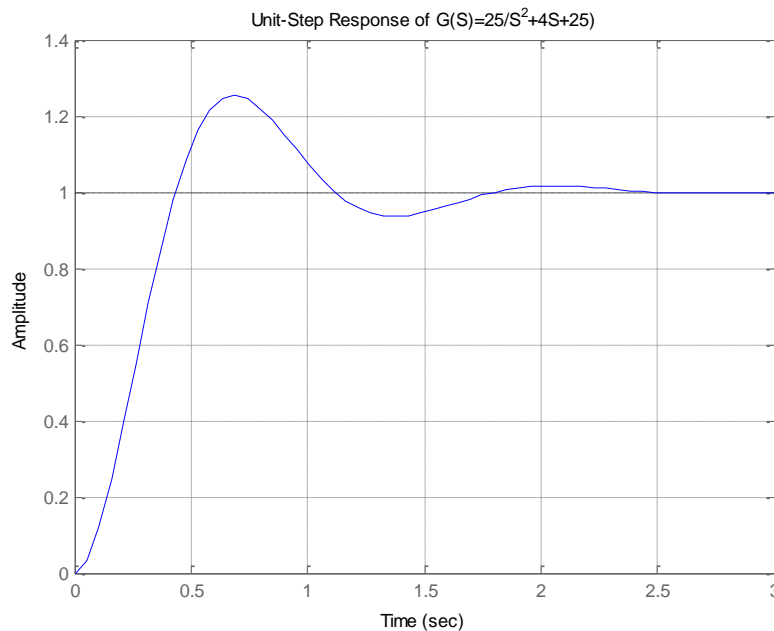

Figure 3-2 Unit-step response curve

Impulse Response .The unit-impulse response of a control system may be obtained by using one of the following MATLAB commands:

$$\textit{impulse}(\textit{num}, \textit{den})$$

$$\textit{impulse}(A, B, C, D)$$

$$[y, x, t] = \textit{impulse}(\textit{num}, \textit{den}) \quad (3 - 7)$$

$$[y, x, t] = \textit{impulse}(\textit{num}, \textit{den}, t)$$

$$[y, x, t] = \textit{impulse}(A, B, C, D)$$

$$[y, x, t] = \textit{impulse}(A, B, C, D, \textit{iu})$$

$$[y, x, t] = \textit{impulse}(A, B, C, D, \textit{iu}, t)$$

The command `impulse (num, den)` plots the unit-impulse response on the screen. The command `impulse (A,B,C,D)` produces a series of unit-impulse-response plots, one for each input and output combination of the system

$$\dot{x} = Ax + Bu$$

$$y = Cx + Du$$

If MATLAB is invoked with the left-hand argument $[y, x, t]$, such as in the case of $[y, x, t] = \textit{impulse}(A, B, C, D)$, the command returns the output and state responses of the system and the time vector t . The matrices y and x contain the output and state responses of the system evaluated at the time points t . y has

many columns as outputs and one row for each element in t . x has many columns.

Example 3-4

Obtain the unit-impulse response of the following system:

$$\begin{bmatrix} \dot{x}_1 \\ \dot{x}_2 \end{bmatrix} = \begin{bmatrix} 0 & 1 \\ -1 & -1 \end{bmatrix} \begin{bmatrix} x_1 \\ x_2 \end{bmatrix} + \begin{bmatrix} 0 \\ 1 \end{bmatrix} u$$

$$y = [1 \quad 0] \begin{bmatrix} x_1 \\ x_2 \end{bmatrix} + [0]u$$

A possible MATLAB program is shown in MATLAB Program .The resulting response curve is shown in figure 3-3.

MATLAB Program
<pre>A=[0 1;-1 -1] B=[0 ;1]; C=[1 0]; D=[0]; impulse(A,B,C,D); grid; title('Unit-Impulse Response')</pre>

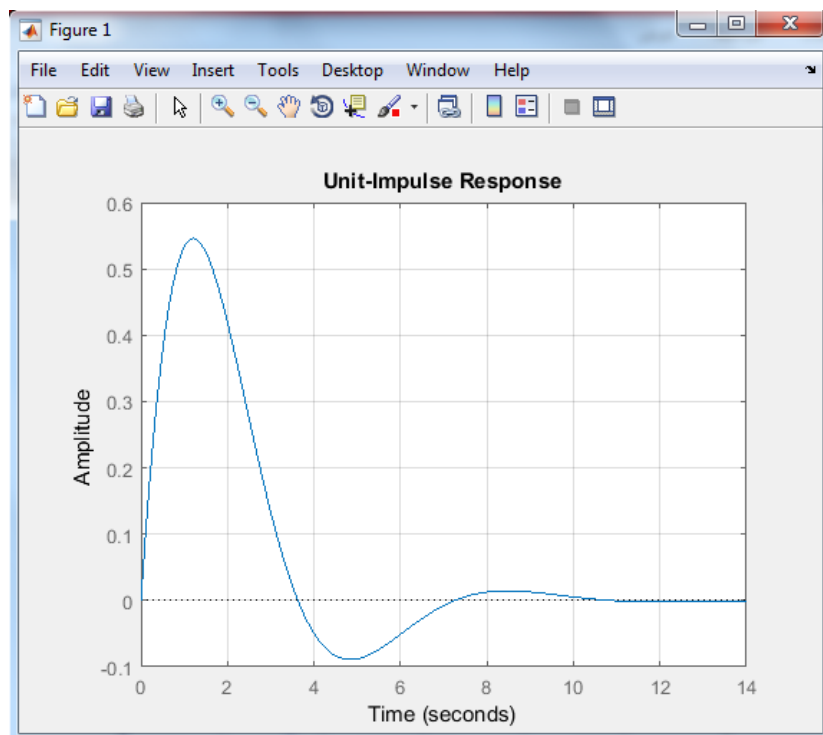

Figure 3-3 Impulse Response

Ramp response

There is no ramp command in MATLAB. Therefore, we need to use the step command or the lsim command to obtain the ramp response. Specifically, to obtain the ramp response of the transfer-function system $G(s)$, divide $G(s)$ by s and use the step-response command.

Example 3-5

Consider the closed loop system

$$\frac{C(s)}{R(s)} = \frac{1}{s^2 + s + 1}$$

For a unit-ramp input, $R(s) = 1/s^2$. Hence

$$C(s) = \frac{1}{s^2 + s + 1} \frac{1}{s^2}$$

To obtain the unit-ramp response of this system, enter the following numerator and denominator into the MATLAB program,

```
num=[0 0 0 1]
```

```
den=[1 1 1 0]
```

and use the step-response command. See MATLAB Program, the plot obtained by using this program is shown in figure 3-4.

MATLAB Program

```
%- ----- U n it-ramp response -----  
% ***** The unit-ramp response is obtained as the unit-step  
% response of G(s)/s *****  
% ***** Enter the numerator and denominator of G(s) *****  
num = [0 0 0 1];  
den = [1 1 1 0];  
% ***** Specify the computing time points (such as t = 0:0.1:7)  
% and then enter step-response command: c = step(num,den,t) *****  
t = 0:0.1:7  
c = step(num,den,t)  
%***** In plotting the ramp-response curve, add the reference  
% input to the plot. The reference input is t. Add to the  
% argument of the plot command with the following: t,t,'-'. Thus  
% the plot command becomes as follows: plot(t,c,'o',t,t,'-') *****  
plot(t,c,'o',t,t,'-')  
% ***** Add grid, title, xlabel, and ylabel *****
```

```

grid
title('Unit-Ramp Response Curve for System G(s) = 1/(s^2 + s + 1)')
xlabel('t Sec')
ylabel('Input and Output')

```

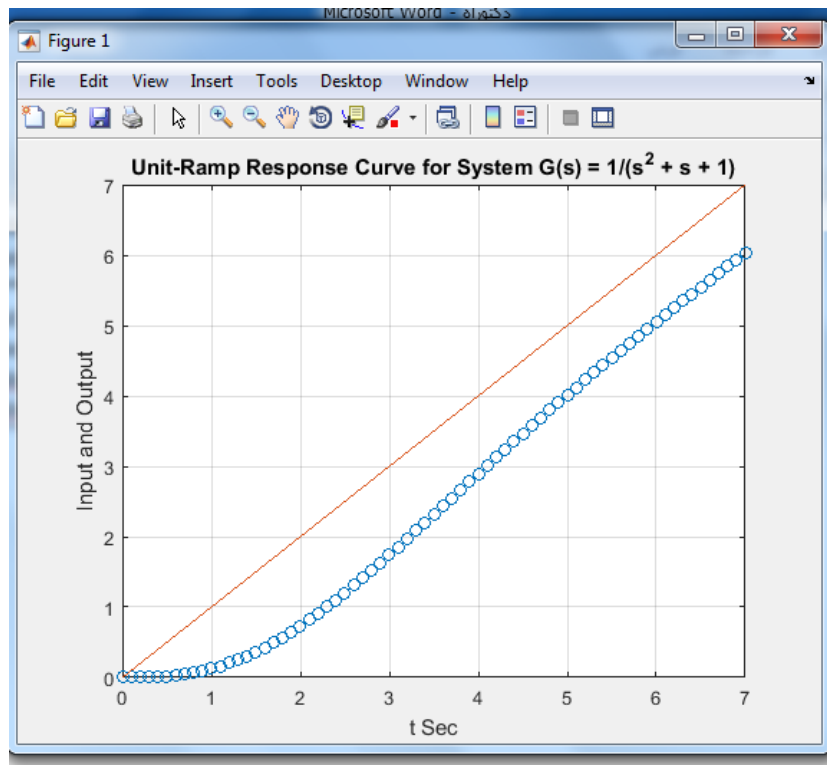

Figure 3-4 Unit Ramp Response Curve for System

Unit-Ramp Response of a System in State Space

Next, we shall treat the unit-ramp response of the system in state-space form.

Consider the system described by

$$\dot{x} = Ax + Bu$$

$$y = Cx + Du$$

To obtain the response to an arbitrary input, the command `lsim` may be used. The commands like

$$lsim(num, den, r, t)$$

$$lsim(A, B, C, D, u, t)$$

$$y = lsim(num, den, r, t)$$

$$y = lsim(A, B, C, D, u, t)$$

Example 3-6

Using the lsim command, obtain the unit-ramp response of the following system:

$$\frac{C(s)}{R(s)} = \frac{1}{s^2 + s + 1}$$

We use MATLAB Program into the computer to obtain the unit-ramp response.

The resulting plot is shown in Figure 3-5.

MATLAB Program

```
% - - - - - Ramp Response - - - - -  
num = [0 0 1];  
den = [1 1 1];  
t = 0:0.1:8;  
r = t;  
y = lsim(num,den,r,t);  
plot(t,r,'-',t,y,'o')  
grid  
title('Unit-Ramp Response Obtained by Use of Command "lsim"')  
xlabel('t Sec')  
ylabel('Unit-Ramp Input and System Output')
```

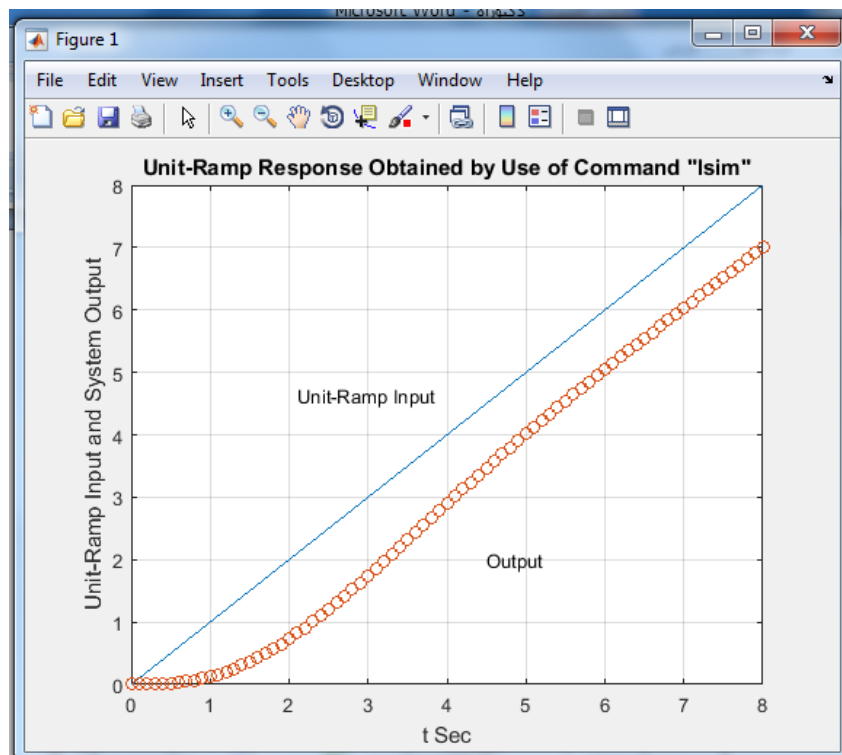

Figure 3-5 Unit Ramp Response

Example 3-7

Consider the system

$$\begin{bmatrix} \dot{x}_1 \\ \dot{x}_2 \end{bmatrix} = \begin{bmatrix} -1 & 0.5 \\ -1 & 0 \end{bmatrix} \begin{bmatrix} x_1 \\ x_2 \end{bmatrix} + \begin{bmatrix} 0 \\ 1 \end{bmatrix} u$$
$$y = [1 \quad 0] \begin{bmatrix} x_1 \\ x_2 \end{bmatrix}$$

Using MATLAB, obtain the response curves $y(t)$ when the input u is given by

1. $u = e^{-t}$

Assume that the initial state is $x(0) = 0$. A possible MATLAB program to produce the responses of this system of the exponential input [$u = e^{-t}$ is shown in MATLAB Program]. The resulting response curves are shown in figures 3-6

MATLAB Program

```
t = 0:0.1:12;
A = [-1 0.5; -1 0];
B = [0; 1];
C = [1 0];
D = [0];

%For the response to exponential input u = exp(-t), use the command
% z = lsim(A,B,C,D,u,t).
u = exp(-t);
z = lsim(A,B,C,D,u,t);
plot(t,u,'-',t,z,'o')
grid
title('Response to Exponential Input u = exp(-t)')
xlabel('t Sec')
ylabel('Exponential Input and System Output')
text(2.3,0.49,'Exponential input')
text(6.4,0.28,'Output')
```

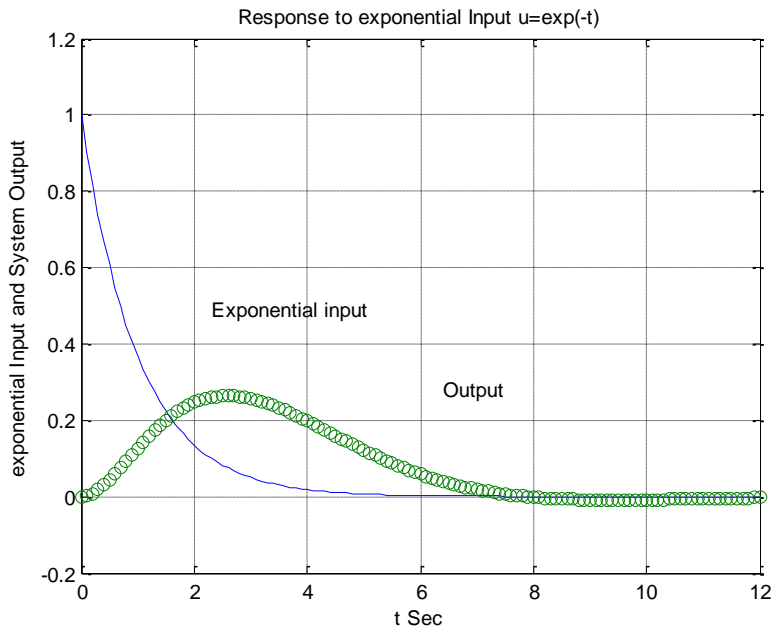

Figures 3-6 Response to exponential input

Example 3-8

Consider the mechanical system shown in Figure 3-7, where $m = 1 \text{ kg}$, $b = 3 \text{ N-sec/m}$, and $k = 2 \text{ N/m}$. Assume that at $t = 0$ the mass m is pulled downward such that $x(0) = 0.1 \text{ m}$ and $\dot{x}(0) = 0.05 \text{ m/sec}$. The displacement $x(t)$ is measured from the equilibrium position before the mass is pulled down. Obtain the motion of the mass subjected to the initial condition. The system equation is with the initial conditions $x(0) = 0.1 \text{ m}$ and $\dot{x}(0) = 0.05 \text{ m/sec}$. the system equation gives

$$m\ddot{x} + b\dot{x} + kx = 0$$

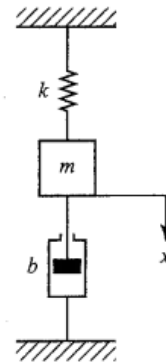

Figure 3-7 mechanical system

With the initial conditions $x(0) = 0.1m$ and $\dot{x}(0) = 0.05m/sec$. (x is measured from the equilibrium position.) The Laplace transform of the system equation gives

$$m[s^2X(s) - sx(0) - \dot{x}(0)] + b[sX(s) - x(0)] + kX(s) = 0$$

$$(ms^2 + bs + k)X(s) = mx(0)s + m\dot{x}(0) + bx(0)$$

Solving this last equation for $X(s)$ and substituting the given numerical values, we obtain

$$X(s) = \frac{mx(0)s + m\dot{x}(0) + bx(0)}{ms^2 + bs + k}$$

$$X(s) = \frac{0.1s + 0.35}{s^2 + 3s + 2}$$

This equation can be written as

$$X(s) = \frac{0.1s^2 + 0.35s}{s^2 + 3s + 2} \frac{1}{s}$$

Hence the motion of the mass m may be obtained as the unit-step response of the following system:

$$X(s) = \frac{0.1s^2 + 0.35s}{s^2 + 3s + 2}$$

MATLAB Program will give a plot of the motion of the mass. The plot is shown in figure 3-8.

MATLAB Program

```
%----- Response to initial condition -----
%***** System response to initial condition is converted to
%a unit-step response by modifying the numerator polynomial *****
%***** Enter the numerator and denominator of the transfer
% function G(s) *****
num = [0.1 0.35 0];
den = [1 3 2];
%***** Enter the following step-response command *****
    step(num,den)
% ***** Enter grid and title of the plot *****
grid
title('Response of Spring-Mass-Damper System to Initial Condition')
```

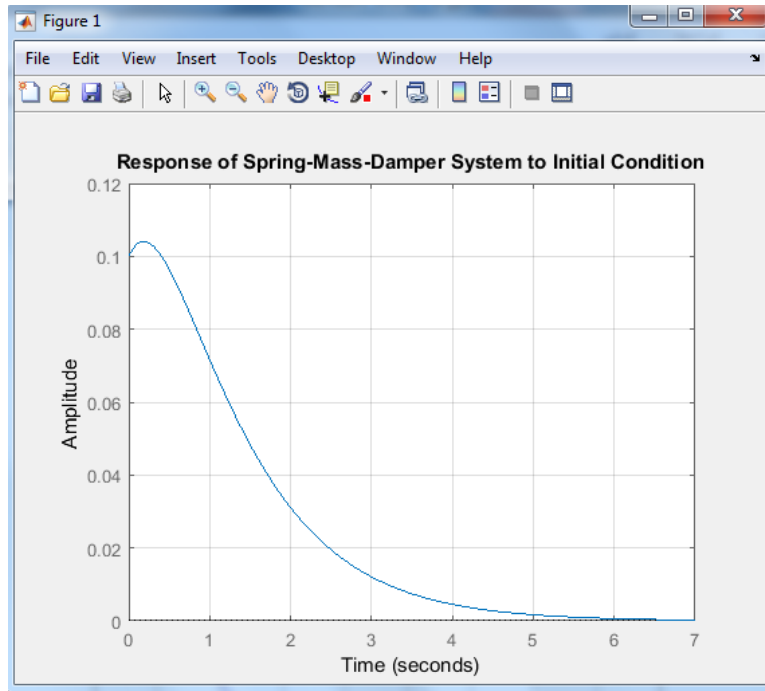

Figure 3-8 Response of Spring- Mass-Damper System to Initial Condition
Response to Initial Condition (State-Space Approach, Case 1)

Consider the system defined by

$$\dot{x} = Ax \quad x(0) = x_0 \quad (3 - 8)$$

Let us obtain the response $x(t)$ when the initial condition $x(0)$ is specified. Assume that x is an n -vector. First, take Laplace transforms of both sides of equation (3-8).

$$sX(s) - x(0) = AX(s)$$

This equation can be rewritten as

$$sX(s) = AX(s) + x(0) \quad (3 - 9)$$

Taking the inverse Laplace transform of Equation (3-9), we obtain

$$\dot{x} = Ax + x(0)\delta(t) \quad (3 - 10)$$

(Notice that by taking the Laplace transform of a differential equation and then by taking the inverse Laplace transform of the Laplace-transformed equation we generate a differential equation that involves the initial condition.) Now define

$$z = x \quad (3 - 11)$$

Then Equation (3-10) can be written as

$$z' = Az + x(0)\delta(t) \quad (3 - 12)$$

By integrating Equation (3-12) with respect to t , we obtain

$$\dot{z} = Az + x(0)1(t) = Az + Bu \quad (3 - 13)$$

Where

$$B = x(0) \quad u = 1(t)$$

Referring to Equation (3-11), the state $x(t)$ is given by $z'(t)$. Thus,

$$x = z' = Az + Bu$$

The solution of equations (3-12) and (3-13) gives the response to the initial condition. Summarizing, the response of equation (3-13) to the initial condition $x(0)$ is obtained by solving the following state-space equations:

$$\dot{z} = Az + Bu$$

$$x = Az + Bu$$

where

$$B = x(0) \quad u = 1(t)$$

MATLAB commands to obtain the response curves in one diagram are given next.

$$[x, z, t] = \text{step}(A, B, A, D);$$

$$x_1 = [1 \ 0 \ 0 \ \dots \ 0] * x';$$

$$x_2 = [0 \ 1 \ 0 \ \dots \ 0] * x';$$

•

•

•

$$x_n = [0 \ 0 \ 0 \ \dots \ 1] * x';$$

$$\text{plot} = (t, x_1, t, x_2, \dots, t, x_n)$$

Response to Initial Condition (State-Space Approach, Case 2)

Consider the system defined by

$$\dot{x} = Ax \quad x(0) = x_0 \quad (3 - 14)$$

$$y = Cx \quad (3 - 15)$$

(Assume that x is an n -vector and y is an m -vector.) Similar to case 1, by defining

$$z' = x$$

we can obtain the following equation

$$\dot{z} = Az + x(0)1(t) = Az + Bu \quad (3 - 16)$$

where

$$B = x(0) \quad u = 1(t)$$

Noting that $x = z'$, Equation (3-15) can be written as

$$y = C z' \tag{3-17}$$

By substituting equation (3-16) into equation (3-17), we obtain

$$y = C(Az + Bu) = CAz + CBu \tag{3-18}$$

The solution of equations (3-16) and (3-18) gives the response of the system to a given initial condition. MATLAB commands to obtain the response curves (output curves y_1 versus t , y_2 versus t , ... , y_m versus t) are shown next.

$$[y, z, t] = \text{step}(A, B, C * A, C * B)$$

$$y_1 = [1 \ 0 \ 0 \ \dots \ 0] * y';$$

$$y_2 = [0 \ 1 \ 0 \ \dots \ 0] * y';$$

.

.

$$y_m = [0 \ 0 \ 0 \ \dots \ 1] * y';$$

$$\text{plot}(t, y_1, t, y_2, \dots, t, y_m)$$

Example 3-9

Obtain the response of the system subjected to the given initial condition.

$$\begin{bmatrix} x_1 \\ x_2 \end{bmatrix}' = \begin{bmatrix} 0 & 1 \\ -10 & -5 \end{bmatrix} \begin{bmatrix} x_1 \\ x_2 \end{bmatrix}, \quad \begin{bmatrix} x_1(0) \\ x_2(0) \end{bmatrix} = \begin{bmatrix} 2 \\ 1 \end{bmatrix}$$

or

$$x' = Ax, x(0) = x_0$$

Obtaining the response of the system to the given initial condition becomes that of solving the unit step response of the following system:

$$z' = Az + Bu$$

$$x = Az + Bu$$

Where

$$B = x(0) \quad u = 1(t)$$

Hence a possible MATLAB program for obtaining the response may be given as shown in MATLAB Program. The resulting response curves are shown in figure 3-10.

MATLAB Program

```
t = 0:0.01:3;
A = [0 1 ; -10 -5];
B = [2 ; 1 ];
[x,z,t]= step(A,B,t);
x1 = [1 0]*x';
x2 = [0 1 ]*x';
plot(t,x1,'x',t,x2,'-')
grid
title('Response to Initial Condition')
xlabel('t Sec')
ylabel('State Variables x1 and x2')
gtext('x1 ')
gtext('x2')
```

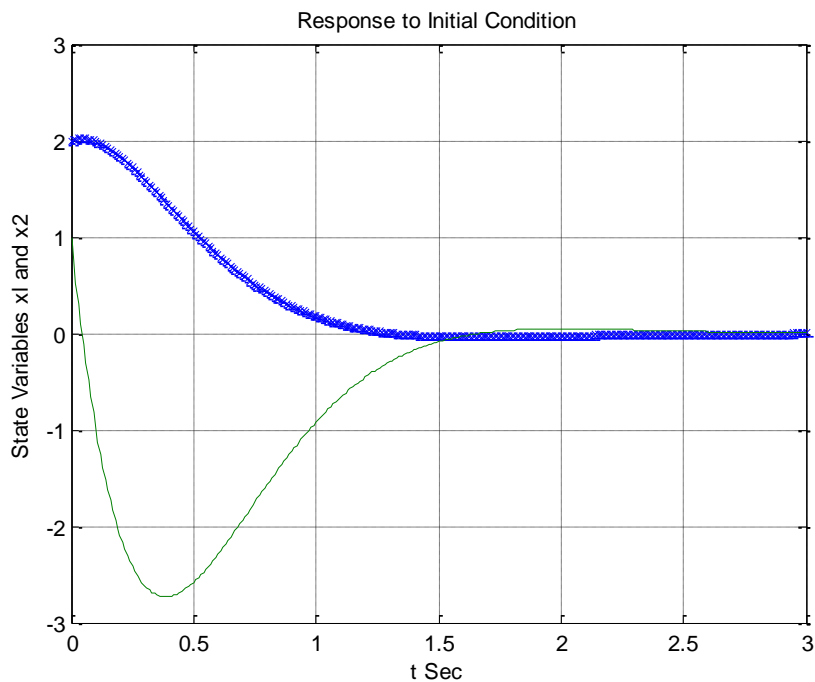

Figure3-10 Response of system initial condition

Obtaining Response to Initial Condition by Use of Command Initial

If the system is given in the state-space form, then the following command

$$\text{Initial (A,B,C,[initial condition],t)}$$

will produce the response to the initial condition. Suppose that we have the system defined by

$$\dot{x} = Ax + Bu \quad x(0) = x_0$$

$$y = Cx + Du$$

Where

$$A = \begin{bmatrix} 0 & 1 \\ -10 & -5 \end{bmatrix} \quad B = \begin{bmatrix} 0 \\ 0 \end{bmatrix} \quad C = [0 \quad 0] \quad D = [0]$$

$$x_0 = \begin{bmatrix} 2 \\ 1 \end{bmatrix}$$

Then the command "initial" can be used as shown in MATLAB Program to obtain the response to the initial condition. The response curves $x_1(t)$ and $x_2(t)$ are shown in figure 3-11.

MATLAB Program

```
t = 0:0.05:3;
A = [0 1 ; -10 -5];
B = [0;0];
C = [0 0];
D = [0 ];
[y,x]= initial(A,B,C,D,[2;1],t);
x1=[1 0]*x';
x2 = [0 1]*x';
plot(t,x1,'o',t,x1,t,x2,'x',t,x2)
grid
title('Response to Initial Condition')
xlabel('t Sec')
ylabel('State Variables x1 and x2')
gtext('x1 ')
gtext('x2')
```

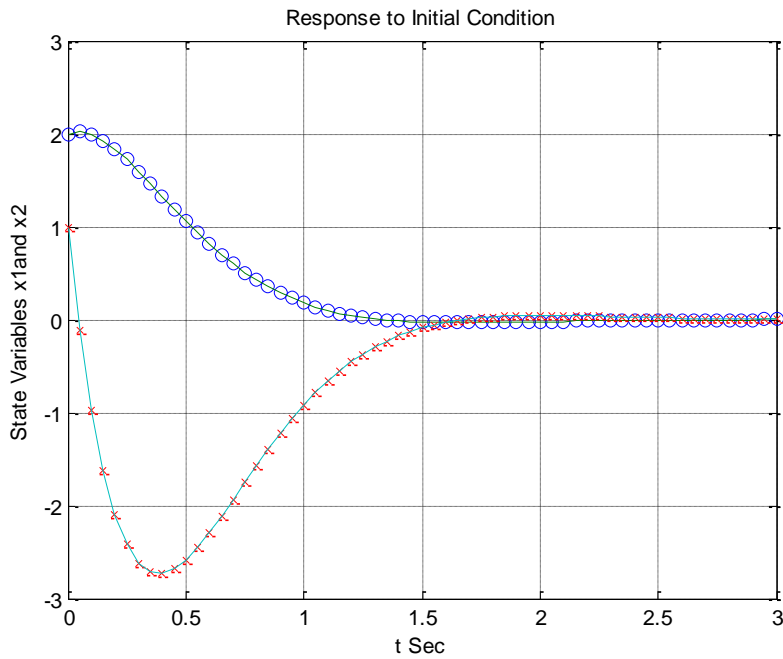

Figure 3-11 Response to Initial Condition

Example 3-10

Consider the following system that is subjected to the initial condition. (No external forcing function is present.)

$$y''' + 8y'' + 17y' + 10y = 0$$

$$y(0) = 2, \quad y'(0) = 1, \quad y''(0) = 0.5$$

Obtain the response $y(t)$ to the given initial condition.

By defining the state variables as

$$x_1 = y$$

$$x_2 = y'$$

$$x_3 = y''$$

We obtain the following state-space representation for the system:

$$\begin{bmatrix} \dot{x}_1 \\ \dot{x}_2 \\ \dot{x}_3 \end{bmatrix} = \begin{bmatrix} 0 & 1 & 0 \\ 0 & 0 & 1 \\ -10 & -17 & -8 \end{bmatrix} \begin{bmatrix} x_1 \\ x_2 \\ x_3 \end{bmatrix}, \quad \begin{bmatrix} x_1(0) \\ x_2(0) \\ x_3(0) \end{bmatrix} = \begin{bmatrix} 2 \\ 1 \\ 0.5 \end{bmatrix}$$

$$y = [1 \quad 0 \quad 0] \begin{bmatrix} x_1 \\ x_2 \\ x_3 \end{bmatrix}$$

A possible MATLAB program to obtain the response $y(t)$ is given in MATLAB Program .The resulting response curve is shown in figure 3-12.

MATLAB Program

```
t = 0:0.05:10;  
A = [0 1 0;0 0 1 ;-10 -1 7 -8];  
B = [0; 0; 0];  
C = [1 0 0];  
D = [0];  
y = initial(A,B,C,D,[2;1;0.5],t);  
plot(t,y)  
grid  
title('Response to Initial Condition')  
xlabel('t (sec)')  
ylabel('Output y')
```

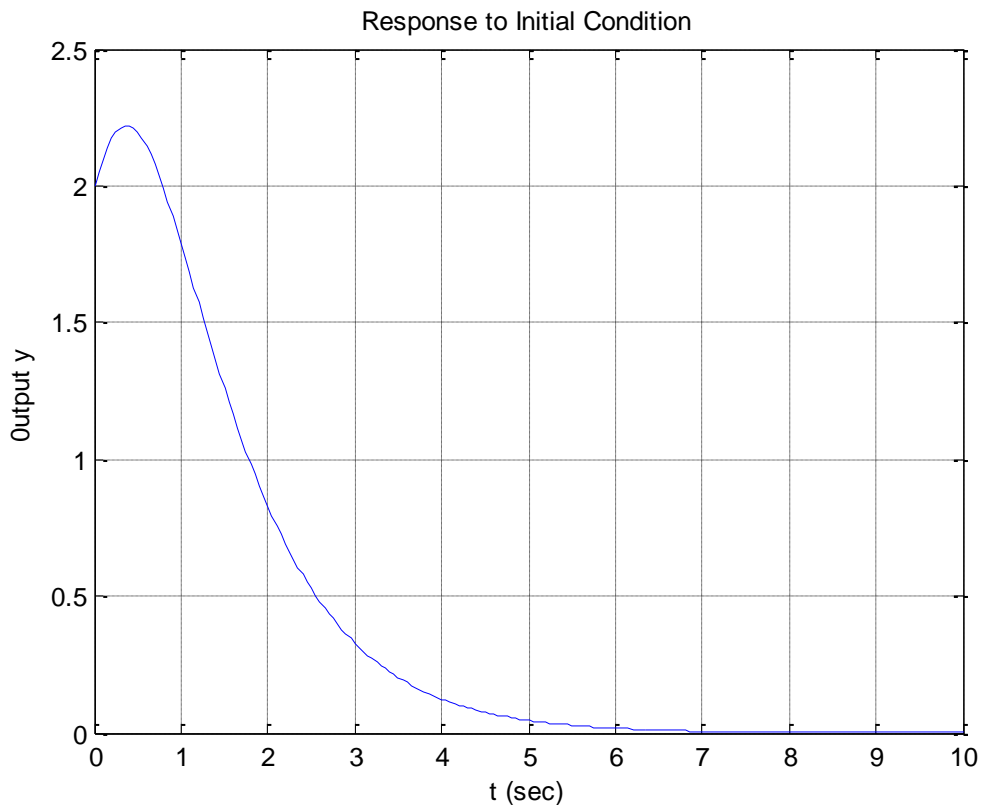

Figure 3-12 Response to Initial Condition

Example 3-11

Obtain both analytical and computational solutions of the unit-step response of a unity-feedback system whose open-loop transfer function is

$$G(s) = \frac{5(s + 20)}{s(s + 4.59)(s^2 + 3.41s + 16.35)}$$

Solution

The closed-loop transfer function is

$$\begin{aligned}\frac{C(s)}{R(s)} &= \frac{5(s+20)}{s(s+4.59)(s^2+3.41s+16.35)+5(s+20)} \\ &= \frac{5s+100}{s^4+8s^3+32s^2+80s+100} \\ &= \frac{5s+100}{(s^2+2s+10)+(s^2+6s+10)}\end{aligned}$$

The unit-step response of this system is then

$$\begin{aligned}C(s) &= \frac{5(s+20)}{(s^2+2s+10)+(s^2+6s+10)} \\ &= \frac{1}{s} + \frac{\frac{3}{8}(s+1) - \frac{17}{8}}{(s+1)^2+3^2} + \frac{-\frac{11}{8}(s+3) - \frac{13}{8}}{(s+3)^2+1^2}\end{aligned}$$

The time response $C(t)$ can be found by taking the inverse Laplace transform of $C(s)$ as follows:

$$C(t) = 1 + \frac{3}{8}e^{-t}\cos 3t - \frac{17}{24}e^{-t}\sin 3t - \frac{11}{8}e^{-t}\cos t - \frac{13}{8}e^{-t}\sin t \quad \text{for } t \geq 0$$

A MATLAB program to obtain the unit-step response of this system. The resulting unit-step response curve is shown in figure 3-13.

MATLAB Program

```
% ----- U nit-step-response -----  
num = [0 0 5 100];  
den = [18 32 80 100];  
step(num,den)  
grid  
title('Unit-Step Response of C(s)/R(s) = (5s + 100)/(s^4 + 8s^3 + 32s^2 + 80s + 100)')
```

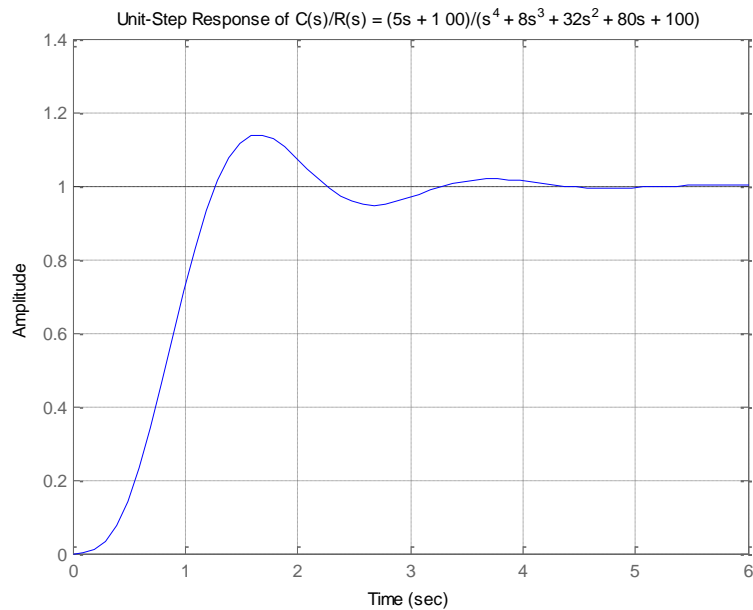

Figure 3-13 Unit Response

Example 3-12

Obtain the response of the closed-loop system defined by

$$\frac{C(s)}{R(s)} = \frac{5}{s^2 + s + 5}$$

When the input $r(t)$ is given by

$$r(t) = 2 + t$$

The input $r(t)$ is a step input of magnitude 2 plus unit-ramp input.

A possible MATLAB program is shown in MATLAB Program. The resulting response curve, together with a plot of the input function, is shown in figure 3-14

MATLAB Program

```
num = [005];
den = [1 1 5];
t = 0:0.05:10;
r = 2+t;
c = lsim(num,den,r,t);
plot(t,r,'-',t,c,'o')
grid
title('Response to Input r(t) = 2 + t')
xlabel('t Sect)
ylabel('Output c(t) and Input r(t) = 2 + t')
```

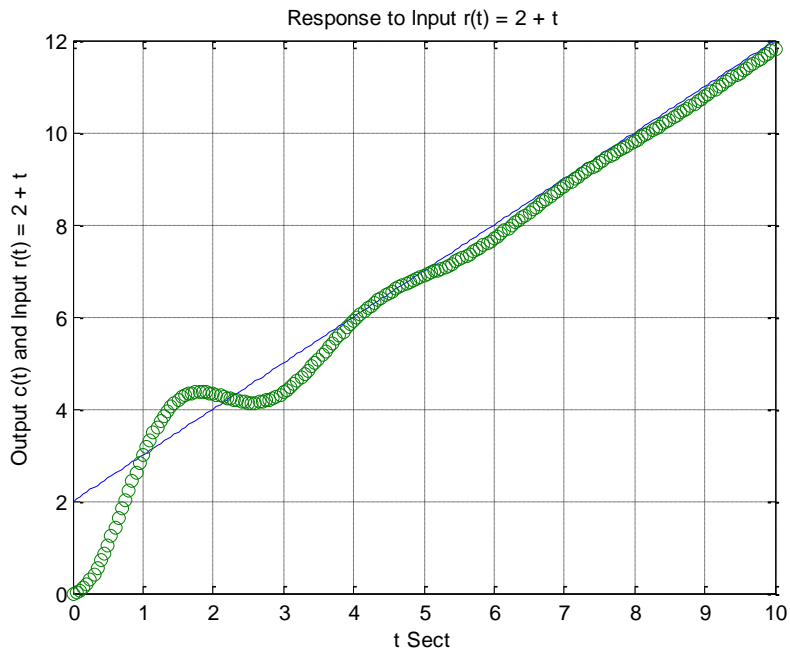



Figure 3-14 Response to input $r(t) = 2 + t$.

Example 3-13

Obtain the response of the system shown in Figure 3-13 when the input $r(t)$ is given by

$$r = \frac{1}{2}t^2$$

Solution

The closed-loop transfer function is

$$\frac{C(s)}{R(s)} = \frac{2}{s^2 + s + 2}$$

MATLAB Program produces the unit-acceleration response. The resulting response, together with the unit-acceleration input, is shown in figure 3-15.

MATLAB Program

```
num = [ 0 0 2];
den = [1 1 2];
t = 0:0.2:10;
r = 0.5*t^2;
y = lsim(num,den,r,t);
plot(t,r, '- ',t,y,'o',t,y, '- ')
grid
title('Unit-Acceleration Response')
xlabel('t Sec')
ylabel('Input and Output')
```

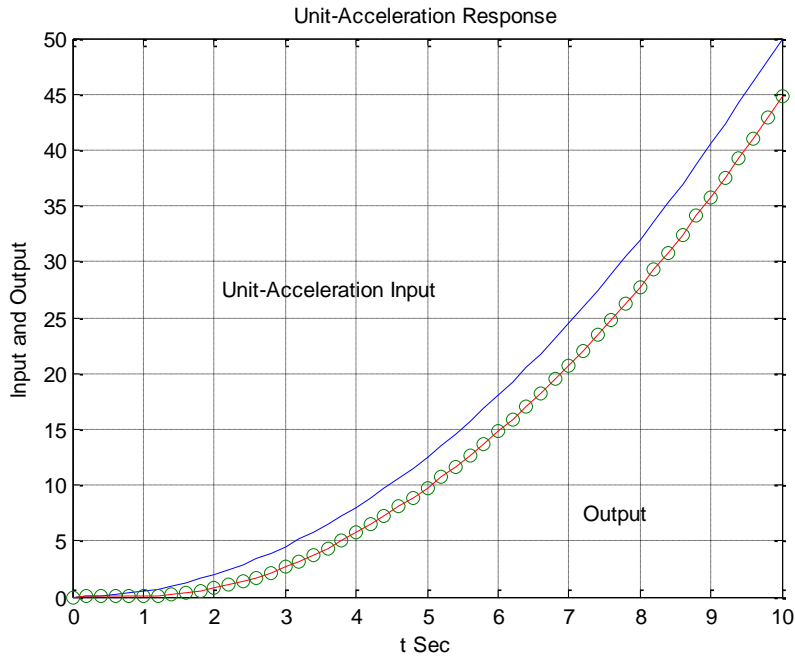

Figure 3-15 Response to unit acceleration input

3.4 Modifications of PID Control Schemes

Consider the basic PID control system shown in Figure (a) blew, where the system is subjected to disturbances and noises. Figure (b) is a modified block diagram of the same system. In the basic PID control system such as the one shown in Figure(b), if the reference input is a step function, then, because of the presence of the derivative term in the control action, the manipulated variable $u(t)$ will involve an impulse function (delta function). In an actual PID controller, instead of the pure derivative term, we employ.

$$\frac{T_d s}{1 + \gamma T_d s} \quad (3-19)$$

Where the value of γ is somewhere around 0.1. Therefore, when the reference input is a step function, the manipulated variable $u(t)$ will not involve an impulse function, but will involve a sharp pulse function. Such a phenomenon is called set-point kick.

PI-D Control

To avoid the set-point kick phenomenon, we may wish to operate the derivative action only in the feedback path so that differentiation occurs only on the feedback signal and not on the reference signal. The control scheme arranged in this way is called the PI-D control a Figure shows a PI-D-controlled system. From figure blew it can be seen that the manipulated signal $U(s)$ is given by

$$U(s) = K_p \left[1 + \frac{1}{T_i s} \right] R(s) - K_p \left[1 + \frac{1}{T_i s} + T_d s \right] B(s) \quad (3 - 20)$$

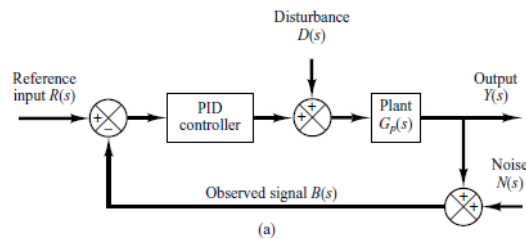
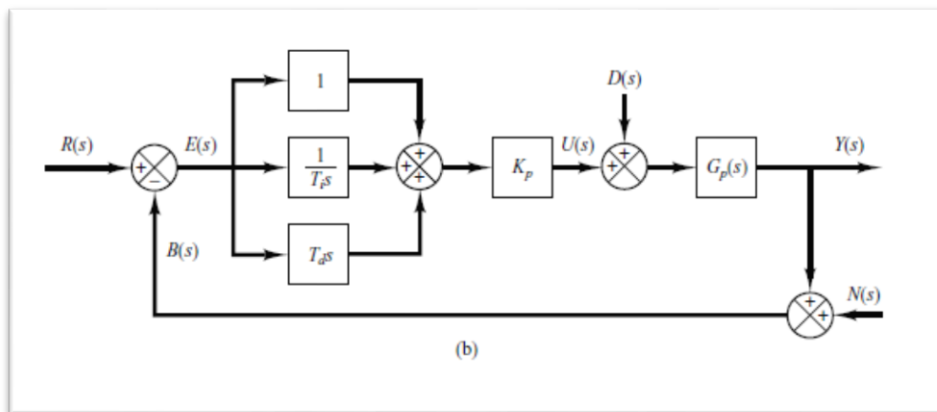

Figure (a) PID controlled system and (b) equivalent block diagram

$$\frac{Y(s)}{R(s)} = \left(1 + \frac{1}{T_i s} + T_d s \right) \left(\frac{K_p G_p}{1 + \left(1 + \frac{1}{T_i s} + T_d s \right) K_p G_p} \right) \quad (3 - 21)$$

$$\frac{Y(s)}{R(s)} = \left(1 + \frac{1}{T_i s} \right) \left(\frac{K_p G_p}{1 + \left(1 + \frac{1}{T_i s} + T_d s \right) K_p G_p} \right)$$

It is important to point out that in the absence of the reference input and noises, the closed-loop transfer function between the disturbance $D(s)$ and the output



$Y(s)$ in either case is the same and is given by

$$\frac{Y(s)}{D(s)} = \frac{G_p s}{1 + K_p(s)G_p(s) \left[1 + \frac{1}{T_i s} + T_d s \right]} \quad (3 - 22)$$

I-PD Control

Consider the case where the reference input is a step function. Both PID control and PI-D control involve a step function in the manipulated signal. Such a step change in the manipulated signal may not be desirable in many occasions. Therefore, it may be advantageous to move the proportional action and derivative action to the feedback path so that these actions affect the feedback signal only. Figure 3-16 shows such a control scheme. It is called the I-PD control. The manipulated signal is given by

$$U(s) = K_p \frac{1}{T_i s} R(s) - K_p \left[1 + \frac{1}{T_i s} + T_d s \right] B(s) \quad (3 - 23)$$

Notice that the reference input $R(s)$ appears only in the integral control part. Thus, in I-PD control, it is imperative to have the integral control action for proper operation of the control system.

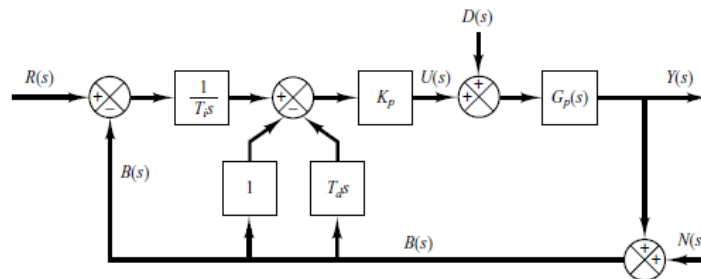

Figure 3-16 I-PD controlled system

The closed-loop transfer function $Y(s)/R(s)$ in the absence of the disturbance input and noise input is given by

$$\frac{Y(s)}{R(s)} = \left[\frac{1}{T_i s} \right] \frac{K_p G_p(s)}{1 + K_p G_p(s) \left[1 + \frac{1}{T_i s} + T_d s \right]}$$

It is noted that in the absence of the reference input and noise signals, the closed-loop transfer function between the disturbance input and the output is given by

$$\frac{Y(s)}{D(s)} = \frac{G_p(s)}{1 + K_p G_p(s) \left[1 + \frac{1}{T_i s} + T_d s \right]}$$

This expression is the same as that for PID control or PI-D control.

The basic idea of the I-PD control is to avoid large control signals (which will cause a saturation phenomenon) within the system. By bringing the proportional and derivative control actions to the feedback path, it is possible to choose larger values for K_p and T_d than those possible by the PID control scheme. Compare, qualitatively, the responses of the PID-controlled system and I-PD-controlled system to the disturbance input and to the reference input. Consider first the response of the I-PD-controlled system to the disturbance input. Since, in the I-PD control of a plant, it is possible to select larger values for K_p and T_d than those of the PID-controlled case, the I-PD-controlled system will attenuate the effect of disturbance faster than the PID-controlled case. Next, consider the response of the I-PD-controlled system to a reference input. Since the I-PD-controlled system is equivalent to the PID-controlled system with input filter, the PID-controlled system will have faster responses than the corresponding I-PD-controlled system, provided a saturation phenomenon does not occur in the PID-controlled system

Example 3-14

Show that the I-PD controlled system show in figure is equivalent to the PID controlled system with input filter shown in figure

Solution

The closed loop transfer function $C(t)/R(t)$ of the I-PD controlled system is

$$\frac{C(s)}{R(s)} = \frac{\frac{K_p}{T_i s} G_p(s)}{1 + K_p \left(1 + \frac{1}{T_i s} + T_d s\right) G_p(s)}$$

The closed loop transfer function $C(t)/R(t)$

of the PID controlled system with input filter show in figure is

$$\frac{C(s)}{R(s)} = \frac{1}{1 + T_i s + T_i T_d s^2} \frac{K_p \left(1 + \frac{1}{T_i s} + T_d s\right) G_p(s)}{1 + K_p \left(1 + \frac{1}{T_i s} + T_d s\right) G_p(s)}$$

$$\frac{C(s)}{R(s)} = \frac{\frac{K_p}{T_i s} G_p(s)}{1 + K_p \left(1 + \frac{1}{T_i s} + T_d s\right) G_p(s)}$$

The closed loop transfer functions of both systems are the same thus the two system are equivalent

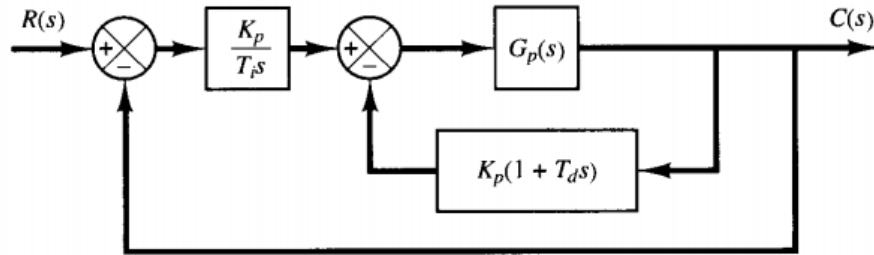

(a)

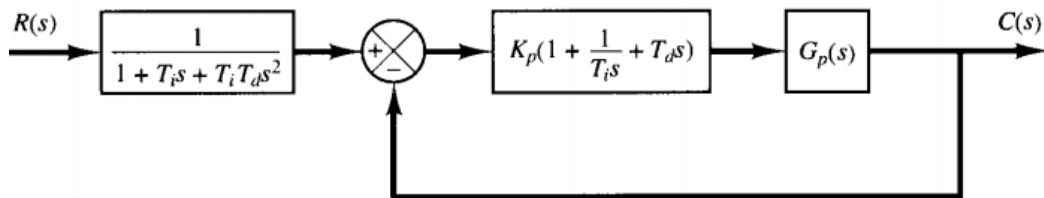

(b)

(a) I-PD controlled system (b) PID controlled system with input filter

Chapter 4

Two-Degrees-of-Freedom PID Control

4.1 Introduction

We have shown that PI-D control is obtained by moving the derivative control action to the feedback path, and I-PD control is obtained by moving the proportional control and derivative control actions to the feedback path. Instead of moving the entire derivative control action or proportional control action to the feedback path, it is possible to move only portions of these control actions to the feedback path, retaining the remaining portions in the feed forward path. In the literature, PI-PD control has been proposed. The characteristics of this control scheme lie between PID control and I-PD control. Similarly, PID-PD control can be considered. In these control schemes, we have a controller in the feed forward path and another controller in the feedback path. Such control schemes lead us to a more general two-degrees-of-freedom control scheme. We shall discuss details of such a two degrees of freedom control scheme in subsequent sections.

4.2 Two Degree of Freedom Control

As in most of the existing industrial process control applications, the desired value of the controlled variable, or set-point, normally remains constant but needs to be changed servo-control or set point tracking operation, we are mainly interested in the two-degree-of-freedom(2DoF) implementation of the PID control algorithms. The extra parameter that the 2 DoF control algorithm provides is used to improve their servo-control behavior while considering the regulatory control performance and the closed-loop control system robustness. This 2DoF feature can be incorporated both into a PI or a PID control algorithm. Although all the controllers with a proportional integral (PI) control algorithm are implemented in the same way, have the same transfer function, this is not the case with commercial controllers with proportional integral derivative (PID) control algorithms. In fact, usually, the control algorithm implementation is manufacturer dependent and not all of its variations are available in the same controller.

Consider the system shown in Figure below, where the system is subjected to the disturbance input $D(s)$ and noise input $N(s)$, in addition to the reference input $R(s)$. $G_c(s)$ is the transfer function of the controller and $G_p(s)$ is the transfer function of the plant. We assume that $G_p(s)$ is fixed and unalterable

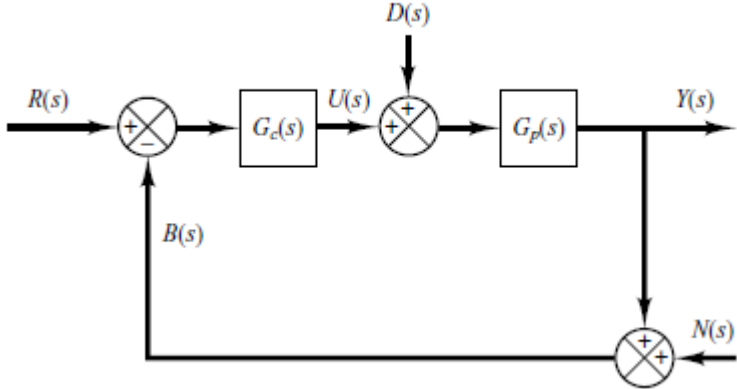

Figure 4-1 One-degree-of freedom control system

For this system, three closed-loop transfer functions $Y(s)/R(s) = G_{yr}$, $Y(s)/D(s) = G_{yd}$, and $Y(s)/N(s) = G_{yn}$ may be derived. They are.

$$G_{yr} = \frac{Y(s)}{R(s)} = \frac{G_c G_p}{1 + G_c G_p}$$

$$G_{yd} = \frac{Y(s)}{D(s)} = \frac{G_p}{1 + G_c G_p}$$

$$G_{yn} = \frac{Y(s)}{N(s)} = \frac{G_c G_p}{1 + G_c G_p}$$

In deriving $Y(s)/R(s)$, we assumed $D(s) = 0$ and $N(s) = 0$. Similar comments apply to the derivations of $Y(s)/D(s)$ and $Y(s)/N(s)$. The degrees of freedom of the control system refers to how many of these closed-loop transfer functions are independent. In the present case, we have

$$G_{yr} = \frac{G_p - G_{yd}}{G_p}$$

$$G_{yn} = \frac{G_{yd} - G_p}{G_p}$$

Among the three closed-loop transfer functions G_{yr} , G_{yn} , and G_{yd} if one of them is given, the remaining two are fixed. This means that the system shown in figure 4-1 is a one-degree-of-freedom control system. Next consider the system shown

in Figure, where $G_P(s)$ is the transfer function of the plant. For this system, closed-loop transfer functions G_{yr} , G_{yn} , and G_{yd} are given, respectively, by

$$G_{yr} = \frac{Y(s)}{R(s)} = \frac{G_{c1}G_P}{1 + (G_{c1} + G_{c2})G_P} \quad (4 - 1)$$

$$G_{yd} = \frac{Y(s)}{D(s)} = \frac{G_P}{1 + (G_{c1} + G_{c2})G_P} \quad (4 - 2)$$

$$G_{yn} = \frac{Y(s)}{N(s)} = \frac{(G_{c1} + G_{c2})G_P}{1 + (G_{c1} + G_{c2})G_P} \quad (4 - 3)$$

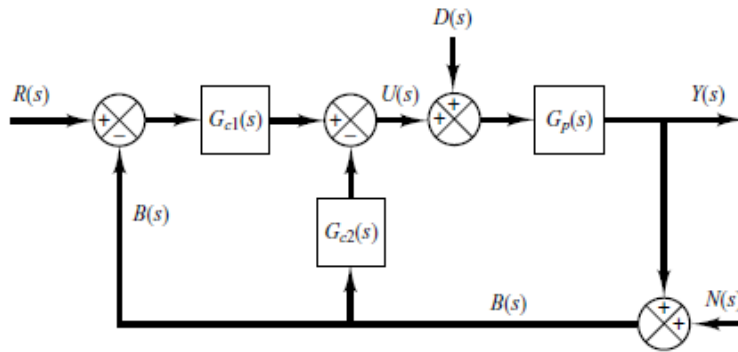

Figure 4-2 Two degrees of freedom control system

$$G_{yr} = G_{c1}G_{yd}$$

$$G_{yn} = \frac{G_{yd} - G_p}{G_p}$$

In this case, if G_{yd} is given, then G_{yn} is fixed, but G_{yr} is not fixed, because G_{c1} is independent of G_{yd} . Thus, two closed-loop transfer functions among three closed-loop transfer functions G_{yr} , G_{yd} , and G_{yn} are independent. Hence, this system is a two-degrees-of-freedom control system. Similarly, the system shown in Figure 4-3 is also a two-degrees-of-freedom control system, because for this system

$$G_{yr} = \frac{Y(s)}{R(s)} = \frac{G_{c1}G_p}{1 + G_{c1}G_p} + \frac{G_{c2}G_p}{1 + G_{c1}G_p}$$

$$G_{yd} = \frac{Y(s)}{D(s)} = \frac{G_p}{1 + G_{c1}G_p}$$

$$G_{yn} = \frac{Y(s)}{N(s)} = \frac{G_{c1}G_p}{1 + G_{c1}G_p}$$

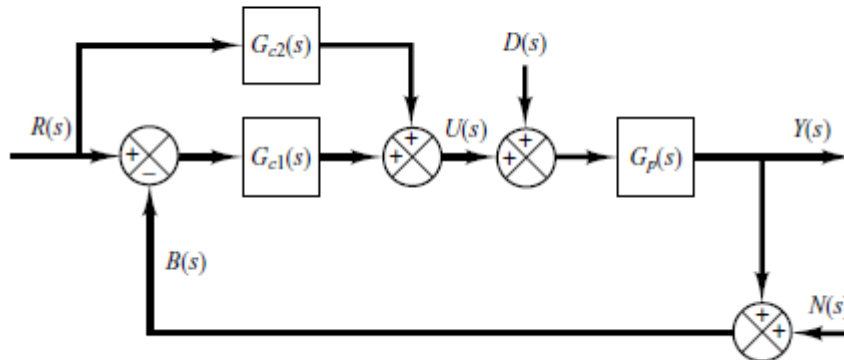

Figure 4-3 Two degree of PID control

Hence

$$G_{yr} = G_{c2}G_{yd} + \frac{G_p - G_{yd}}{G_p}$$

$$G_{yn} = \frac{G_{yd} - G_p}{G_p}$$

Clearly, if G_{yd} is given, then G_{yn} is fixed, but G_{yr} is not fixed, because G_{c2} is independent of G_{yd} .

Example 4-1

Consider the two-degrees-of-freedom control system shown in Figure below. The plant $G_p(s)$ is given by

$$G_p(s) = \frac{100}{s(s+1)} \quad (4-4)$$

Assuming that the noise input $N(s)$ is zero, design controllers $G_{c1}(s)$ and $G_{c2}(s)$ such that the designed system satisfies the following:

1. The response to the step disturbance input has small amplitude and settles to zero quickly (on the order of 1 sec to 2 sec).

2. The response to the unit-step reference input has a maximum overshoot of 25% or less, and the settling time is 1 sec or less.
3. The steady-state errors in following ramp reference input and acceleration reference input are zero.

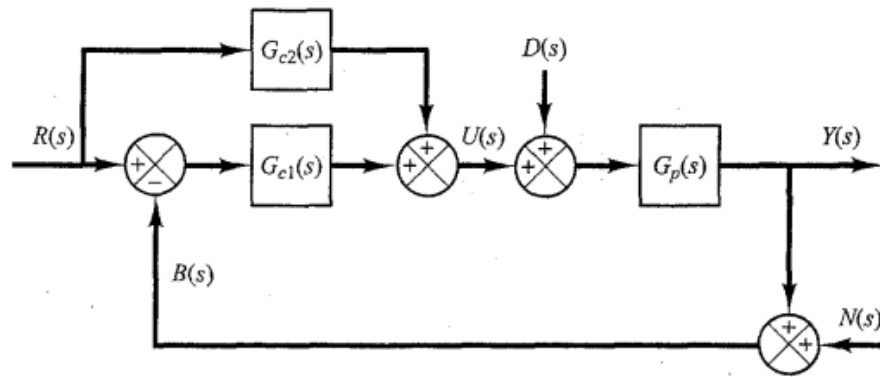

Figure 4-4 Two-degrees-of- freedom control system

Solution

The closed-loop transfer functions for the disturbance input and reference input are given, respectively, by

$$\frac{Y(s)}{D(s)} = \frac{G_P(s)}{1 + G_{c1}(s)G_P(s)}$$

$$\frac{Y(s)}{R(s)} = \frac{G_P(s)}{1 + G_{c1}(s)G_P(s)}$$

Let us assume that $G_{c1}(s)$ is a PID controller and has the following form:

$$G_{c1}(s) = K \frac{(s + a)^2}{s} \quad (4 - 5)$$

The characteristic equation for the system is

$$1 + G_{c1}(s)G_P(s) = 1 + K \frac{(s + a)^2}{s} \frac{100}{s(s + 1)}$$

Notice that the open-loop poles are located at $s = 0$ (a double pole) and $s = -1$. The zeros are located at $s = -a$ (a double zero). In what follows, we shall use the root-locus approach to determine the values of a and K . Let us choose the dominant closed-loop poles at $s = -5 + 5i$. Then, the angle deficiency at the desired closed-loop pole at $s = -5 + 5i$ is

$$-135^\circ - 135^\circ - 128.66^\circ + 180^\circ = -218.66^\circ$$

The double zero at $s = -a$ must contribute 218.66° . By a simple calculation, we find

$$a = -3.2460$$

The controller $G_{c1}(s)$ is then determined as

$$G_{c1}(s) = \frac{K(s + 3.2460)^2}{s}$$

The constant K must be determined by use of the magnitude condition. This condition is

$$|G_{c1}(s)G_P(s)|_{s=-5+5i} = 1$$

$$G_{c1}(s)G_P(s) = K \frac{(s + a)^2}{s} \frac{100}{s(s + 1)}$$

$$K = \left| \frac{s^2 + (s + 1)}{100(s + 3.2460)^2} \right|_{s=-5+5i} = 0.11403$$

The controller $G_{c1}(s)$ thus become

$$\begin{aligned} G_{c1} &= \frac{0.11403(s + 3.2460)^2}{s} \\ &= \frac{0.11403s^2 + 0.7403s + 1.20148}{s} \\ &= 0.7403 + \frac{1.20148}{s} + 0.11403s \end{aligned}$$

Then, the closed-loop transfer function $Y(s)/D(s)$ is obtained as follow

$$\begin{aligned} \frac{Y(s)}{D(s)} &= \frac{G_P(s)}{1 + G_{c1}(s)G_P(s)} & (4 - 6) \\ &= \frac{\frac{100}{s(s+1)}}{1 + \frac{0.11403(s+3.2460)^2}{s} \frac{100}{s(s+1)}} \\ &= \frac{100s}{s^3 + 12.403s^2 + 74.0284s + 120.148} \end{aligned}$$

The response curve when $D(s)$ is a unit-step disturbance is shown in Figure blew

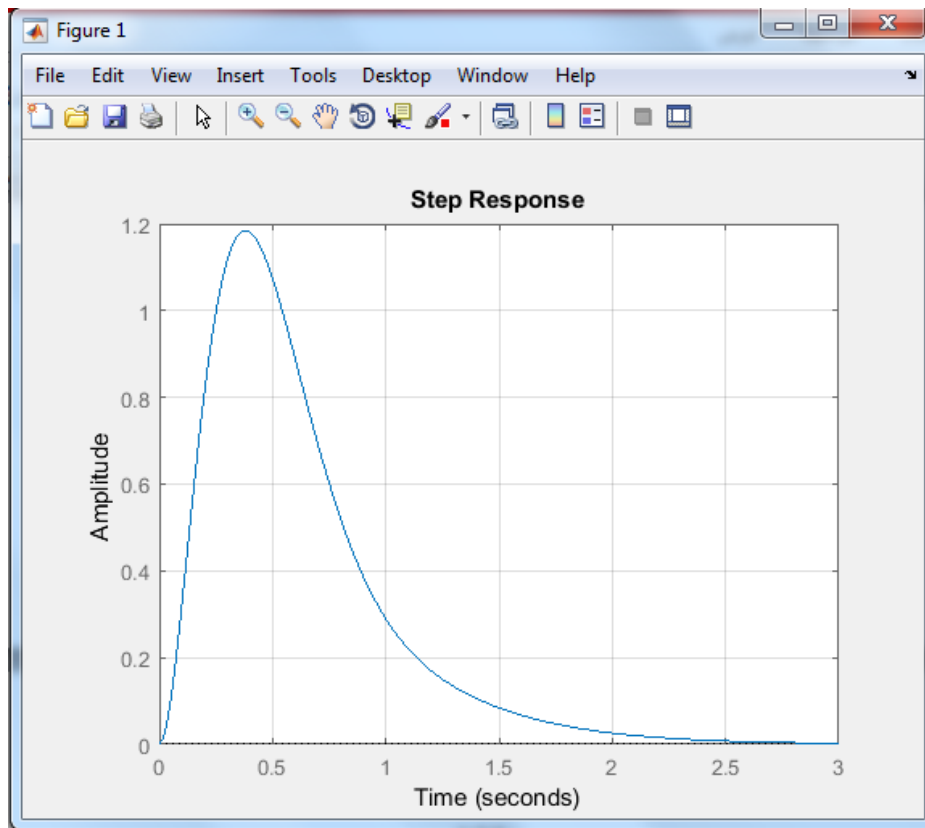

Next, we consider the responses to reference inputs. The closed-loop transfer function $Y(s)/R(s)$ is

$$\frac{Y(s)}{R(s)} = \frac{[G_{c1}(s) + G_{c2}(s)]G_P(s)}{1 + G_{c1}(s)G_P(s)} \quad (4 - 7)$$

$$G_{c1}(s) + G_{c2}(s) = G_c(s)$$

Then

$$\begin{aligned} \frac{Y(s)}{R(s)} &= \frac{G_c(s)G_p(s)}{1 + G_c(s)G_p(s)} \\ &= \frac{100sG_c(s)}{s^3 + 12.403s^2 + 74.0284s + 120.148} \end{aligned}$$

To satisfy the requirements on the responses to the ramp reference input and acceleration reference input, we use the zero-placement approach. That is, we choose the numerator of $Y(s)/R(s)$ to be the sum of the last three terms of the denominator, or

$$100sG_c(s) = 12.403s^2 + 74.0284s + 120.148$$

We get

$$\begin{aligned} G_c(s) &= \frac{12.403s^2 + 74.0284s + 120.148}{s} \\ &= 0.7403 + \frac{120.148}{s} + 12.403s \end{aligned}$$

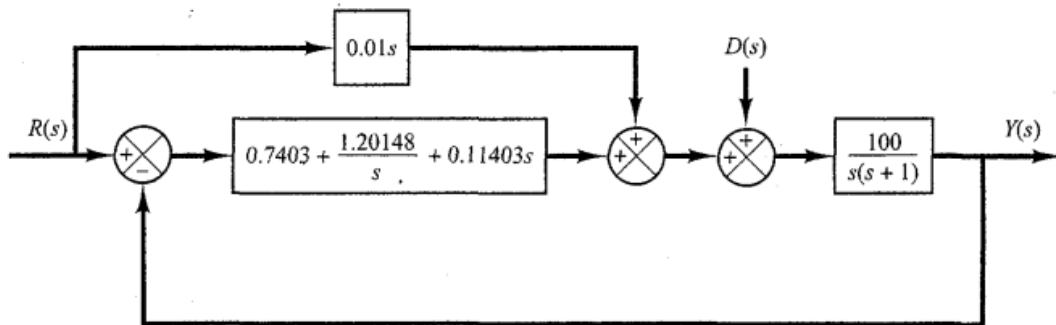

Figure 4-5 control system

Hence, the closed-loop transfer function $Y(s)/R(s)$ becomes as

$$\frac{Y(s)}{R(s)} = \frac{12.403s^2 + 74.0284s + 120.148}{s^3 + 12.403s^2 + 74.0284s + 120.148}$$

2-DOF PID controller

The design of control systems is a multi-objective problem, so a two degree-of-freedom (abbreviated as 2DOF) control system naturally has advantages over a one degree-of freedom (abbreviated as 1DOF) control system. The process will be controlled with a two-degree-of-freedom proportional integral derivative (PID) controller whose output is expressed as in equation (1). A general form of the 2-DOF PID controller is shown in Figure below, where the controller consists of two compensators $G_{ff}(s)$, $G_c(s)$ which are known as

1. Set point controller transfer function also known as feed-forward compensator which is $G_{ff}(s)$ and given by

$$G_{ff}(s) = K \left[\beta + \frac{1}{T_i s} \right] \tag{4 - 8}$$

2. Feedback transfer function (feedback compensator) which is $G_c(s)$ is given by

$$G_c(s) = K \left[1 + \frac{1}{T_i s} + sT_d \right] \tag{4 - 9}$$

Where, β is set point weighting factor or controller parameter ($0 \leq \beta \leq 1$) and K, T_i, T_d are PID controller parameter that is Proportional Gain K_p , integral time T_i and derivative time T_d respectively. The block diagram of this controller is shown in figure 4-6

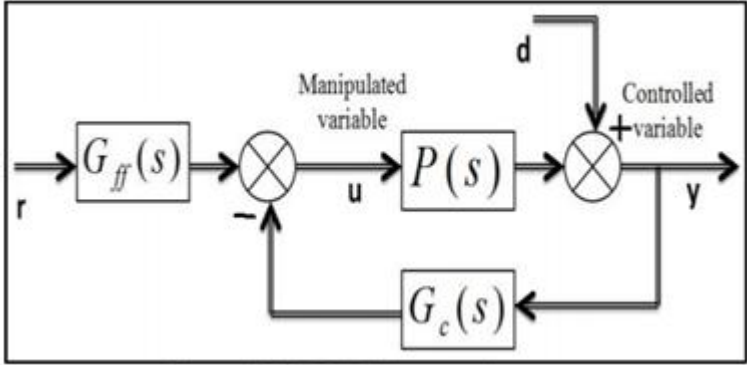

Figure4-6 DOF PID controller structure

Where, $P(s)$ = Plant transfer function, u = Manipulated variable, y =controlled variable or output, r = set point. Manipulated variable (u) for continuous controller is given as

$$u(t) = K_p \left[\beta r(t) - y(t) \frac{1}{T_i s} (r(t) - y(t) + sT_d y(t)) \right] \quad (4 - 10)$$

For the purpose of analysis only, the controller output (4) will be rewritten as follows:

$$u(t) = K_p \left[\beta r(t) - \frac{1}{T_i s} \right] r(t) - K_p \left[1 + \frac{1}{T_i s} + T_d s \right]$$

$$u(t) = G_{ff}(s)r(t) - G_c(s)y(t)$$

The closed-loop transfer function from the set-point to the controlled variable is given by

$$\frac{y(s)}{r(s)} = M_{yr}(s) = \frac{G_{ff}(s)P(s)}{1 + G_c(s)P(s)}$$

Where, the loop sub index has been suppressed for simplicity. In addition the closed-loop transfer function from the load-disturbance to the controlled variable is given by

$$\frac{y(s)}{d(s)} = M_{yd}(s) = \frac{P(s)}{1 + G_c(s)P(s)}$$

Which are related by

$$M_{yr}(s) = G_{ff}(s)M_{yd}(s)$$

Many different ways of discretize the continuous controller of equation 4.

However here forward difference approximation is used for integral mode and backward difference approximation is used for derivative mode. So after discretizing, final discrete 2-DOF controller equation is

$$u(n) = \frac{T_c(z)}{R_c(z)} r(n) - \frac{S_c(z)}{R_c(z)} y(n)$$

Where $\frac{T_c(z)}{R_c(z)}$ is feed-forward compensator and $\frac{S_c(z)}{R_c(z)}$ is feedback compensator, and $R_c(z)$, $S_c(z)$, $T_c(z)$ are given by following polynomials

$$R_c(z) = [1 - z^{-1}]$$

$$T_c(z) = [\beta + (b_i - \beta)z^{-1}]$$

$$S_c(z) = [1 + b_d]$$

Controller Design:

The second order processes without time delay are represented by a linear model in the form of following general transfer function

$$P(s) = \frac{K}{(T_1s + 1)(T_2s + 2)} \quad (4 - 11)$$

Where, K is gain, T_1 and T_2 are time constant. Usually the design of two-degree-of-freedom PID controller is performed in two stages. First the parameter pid K, T_1 and T_2 of the feedback controller required to obtain the desired regulatory control performance. Second the set-point controller, weighting parameter is used to improve the servo-control performance. In what follows a different approach is taken to obtain PID controller parameter. The complete set of PID controller parameters are obtained using Good Gain method. Second to obtain set-point controller weighting parameter is obtained using the equation

$$\beta = \min \left\{ \frac{T_i * T_d}{K_p}, 0.8 \right\}$$

So, complete set of parameter of two-degree-of-freedom PID controller are obtained by using these two steps. Two simulation examples are provided. The first one exemplifies the application of the presented method. The system

descriptions used are, however, of higher order and second order system without time delay are therefore used. The performance of the two-degree-of-freedom PID controller is compared to that one of a PID controller, therefore showing the benefits of using the 2-DOF control configuration.

Example 4-2

Consider that second order controlled process without time delay or fast process is given by

$$P(s) = \frac{1}{(2s + 1)(0.5s + 1)} \quad (4 - 12)$$

Simplifying above process

$$P(s) = \frac{1}{s^2 + 2.5s + 1}$$

For above example or second order process 2-DOF PID controller is design. Controller parameter obtained using Zeigler –Nicolous method, and these parameters are $K_p = 32$, $T_i = 2.55$, $T_d = 0.6375$.

Proportional Integral Derivative Control Algorithm

Consider the general controller block diagram depicted in Fig blew. The output or control effort of a proportional (P)integral (I) and derivative (D) control algorithm is given, in general, by

$$U(t) = Action [U_p(t) + U_I(t) + U_D(t) + U_b] \quad (4 - 13)$$

If $0\% \leq U(t) \leq 100\%$, and 0 or 100%, depending on the controller action if the controller output reaches one of its limits. In U_p is the proportional term or proportional control action, given by

$$U_p(t) = K_p E(t) = K_p [R(t) - Y(t)] \quad (4 - 14)$$

with a proportional gain K_p ; U_I is the integral term or integral control action, givenby

$$U_I(t) = K_I \int_0^t E(\xi) d\xi = K_p \int_0^t [R(\xi) - Y(\xi)] d\xi \quad (4 - 15)$$

with an integral gain K_I ; and U_D the derivative term or derivative control action, given by

$$U_D(t) = K_D \frac{dE(t)}{dt} = K_D \frac{d[R(t) - Y(t)]}{dt}$$

with a derivative gain K_p . The controller output bias U_b is usually set of controller inputs $R(t)$ and $Y(t)$, and output $U(t)$ change in the range from 0 to 100%. The controller Action sign, +1 (Reverse) or -1 (Direct), must be selected equal to the controlled process gain sign to preserve the negative feedback characteristic of the control loop.

2DoF Standard PID

2DoF proportional integral derivative control algorithm is the Standard PID whose output is given by the following:

$$u(t) = K_p \left\{ e_p(t) + \frac{1}{T_i} \int_0^t e_i(\xi) d\xi + T_d \frac{de_d(t)}{dt} \right\} \quad (4 - 16)$$

$$u(s) = K_p \left\{ e_p(s) + \frac{1}{T_i s} e_i(s) + \frac{T_d s}{\alpha T_d s + 1} e_d(s) \right\} \quad (4 - 17)$$

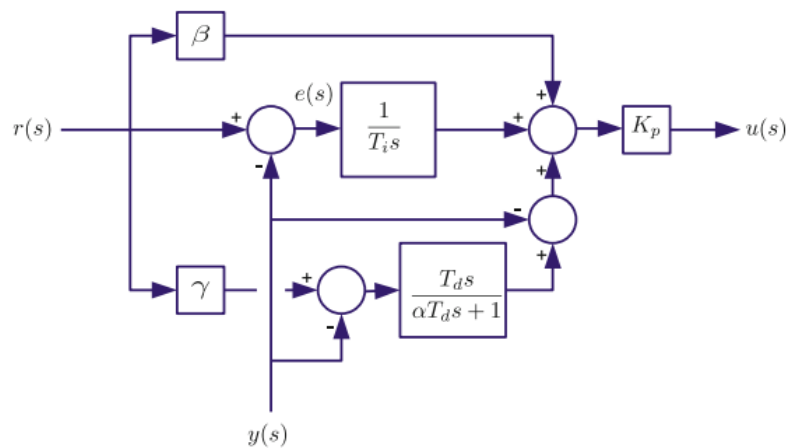

Figure 4-7 Two-degree-of-freedom Standard PID controller

With

$$e_p = \beta r(s) - y'(s)$$

$$e_i = r(s) - y'(s)$$

$$e_d = \gamma r(s) - y'(s)$$

$$y'(s) = y(s) - n(s)$$

Where K_p is the controller gain, T_i the integral time constant, T_d the derivative time constant, β and γ the set-point weights, and α the derivative filter constant. The 2DoF PID block diagram is depicted in Fig above. To avoid an extreme instantaneous change at the controller output signal when a set-point step change occurs normally γ is set to zero. The equation(4-17) reduces to

$$u(s) = K_p \left\{ \beta r(s) - y'(s) + \frac{1}{T_i s} [r(s) - y'(s)] - \left(\frac{T_d s}{\alpha T_d s + 1} \right) y'(s) \right\} \quad (4 - 18)$$

that will be denoted as PID. In addition, in the following it is assumed that the measurement noise is filtered, then $y'(s) \approx y(s)$. The controller output above may be rearranged, for analysis purposes, as follows:

$$u(s) = K_p \left(\beta + \frac{1}{T_i s} \right) r(s) - K_p \left(1 + \frac{1}{T_i s} + \frac{T_d s}{\alpha T_d s + 1} \right) y(s)$$

Where the $C_r(s)$ and $C_y(s)$ controller aspects read as

$$C_r(s) = K_p \left(\beta + \frac{1}{T_i s} \right)$$

$$C_y(s) = K_p \left(1 + \frac{1}{T_i s} + \frac{T_d s}{\alpha T_d s + 1} \right)$$

2DoF Parallel PID

The parallel or “independent gains” PID control algorithm

$$u(s) = \left(\beta_p K_p + \frac{K_i}{s} \right) r(s) - \left(K_p + \frac{K_i}{s} + \frac{K_d s}{\alpha_p K_d s + 1} \right) y(s) \quad (4 - 19)$$

where the $C_r(s)$ and $C_y(s)$ controller aspects read as

$$C_r(s) = \left(\beta_p K_p + \frac{K_i}{s} \right)$$

$$C_y(s) = \left(K_p + \frac{K_i}{s} + \frac{K_d s}{\alpha_p K_d s + 1} \right)$$

2DoF Series or “Industrial” PID

The 2DoF version of the series “interacting” implementation of the PID algorithm

$$u(s) = K_p' \left(\beta' + \frac{1}{T_i' s} \right) r(s) - K_p' \left(1 + \frac{1}{T_i' s} \right) \left(\frac{T_d' s}{\alpha' T_d' s + 1} \right) y(s) \quad (4 - 20)$$

where the $C_r(s)$ and $C_y(s)$ controller aspects read as

$$C_r(s) = K_p' \left(\beta' + \frac{1}{T_i' s} \right)$$

$$C_y(s) = K_p' \left(1 + \frac{1}{T_i' s} \right) \left(\frac{T_d' s}{\alpha' T_d' s + 1} \right)$$

Zero –Input Response and Zero-State Response

The response of linear, in particular LTIL, systems can always be decomposed into the zero-input response and zero-state response. In this section we shall use a simple example to illustrate this fact and then discuss some general properties of the zero input response. The Laplace transform is needed for the following discussion.

Example 4-3

Consider the differential equation

$$\frac{d^2 y(t)}{dt^2} + 3 \frac{dy(t)}{dt} + 2y(t) = 3 \frac{du(t)}{dt} + u(t) \quad (4 - 21)$$

Many methods are available to solve this equation. The simplest method is to use the Laplace transform. The application of the Laplace transform to (4-21) yields,

$$\begin{aligned} s^2 Y(s) - sy(0^-) - y'(0^-) + 3[sY(s) - y(0^-)] + 2Y(s) \\ = 3[sU(s) - u(0^-)] - U(s) \end{aligned} \quad (4 - 22)$$

Where $y(t) = dy(t)/dt$ and capital letters denote the Laplace transforms of the corresponding lower case letters, Equation (4-22) is an algebraic equation and can be manipulated using addition, subtraction, multiplication, and division. The grouping of $Y(s)$ and $U(s)$ in (4-21) yields

$$(s^2 + 3s + 2)Y(s) = sy(0^-) + y'(0^-) + 3y(0^-) - 3u(0^-) + (3s - 1)U(s)$$

Which implies

$$Y(s) = \frac{(s + 3)y(0^-) + y'(0^-) - 3u(0^-)}{s^2 + 3s + 2} + \frac{3s + 1}{s^2 + 3s + 2} U(s) \quad (4 - 23)$$

This equation reveals that the solution of (2-23) is partly excited by the input $u(t)$, $t \geq 0$, and partly excited by the initial conditions $y(0^-)$, and $u(0^-)$. These initial conditions will be called the initial state . The initial state is excited by the input applied before $t = 0$. In some sense, the initial state summarizes the effect of the past input $u(t)$, $t < 0$, on the future output $y(t)$, for $t \geq 0$. If different past

input $u_1(t), u_2(t), \dots, t \leq 0$, excite the same initial state, then their effects on the future output will be identical. Therefore, how the differential equation acquires the initial state at $t = 0$ is immaterial in studying its solution $y(t)$, for $t \geq 0$. We mention that the initial time $t = 0$ is not the absolute time; it is the instant we start to study the system. The response can be decomposed into two parts. The first part is excited exclusively by the initial state and is called the zero-input response. The second part is excited exclusively by the input and is called the zero state response. In the study of LTIL systems, it is convenient to study the zero-input response and the zero-state response separately. We first study the zero-input response and then the zero-state response.

Zero-Input Response-Characteristic Polynomial

Consider the differential equation in (4-21). If $u(t) = 0$, for $t \geq 0$, then reduces

$$\frac{d^2y(t)}{dt^2} + 3\frac{dy(t)}{dt} + 2y(t) = 0 \quad (4-24)$$

This is called the homogeneous equation. We now study its response due to a nonzero initial state. The application of the Laplace transform yields, as in (4-24),

$$s^2Y(s) - sy(0^-) - y'(0^-) + 3[sY(s) - y(0^-)] + 2Y(s) = 0$$

which implies

$$Y(s) = \frac{(s+3)y(0^-) + y'(0^-)}{s^2 + 3s + 2} + \frac{s + 3y(0^-) + y'(0^-)}{(s+1)(s+2)}$$

This can be expanded as

$$Y(s) = \frac{k_1}{s+1} + \frac{k_2}{s+2}$$

$$\text{With } k_1 = \left. \frac{(s+3)y(0^-) + y'(0^-)}{s+2} \right|_{s \rightarrow -1} = 2y(0^-) + y'(0^-)$$

$$\text{And } k_2 = \left. \frac{(s+3)y(0^-) + y'(0^-)}{s+1} \right|_{s \rightarrow -2} = -[y(0^-) + y'(0^-)]$$

Thus the zero-input response is

$$y(t) = K_1 e^{-t} + K_2 e^{-2t}$$

No matter what the initial conditions $y(0^-)$ and $y'(0^-)$ are, the zero-input response is always a linear combination of the two functions e^{-t} and e^{-2t} . The two functions e^{-t} and e^{-2t} are the inverse Laplace transforms of $1/(s+1)$ and

$1/(s + 2)$. The two roots -1 and -2 or, equivalently, the two roots of the denominator of (**) are called the modes of the system . The modes govern the form of the zero-input response of the system. We now extend the preceding discussion to the general case. Consider the n th order LTIL differential equation

$$a_n y^{(n)}(t) + a_{n-1} y^{(n-1)}(t) + \dots + a_1 y^{(1)}(t) + a_0 y(t) = b_m u^{(m)}(t) + b_{m-1} u^{(m-1)}(t) + \dots + b_1 u^{(1)}(t) + b_0 u(t)$$

Where $y^{(i)}(t) = \frac{d^i}{dt^i} y(t)$

$$u^{(i)}(t) = \frac{d^i}{dt^i} u(t)$$

We define

$$D(p) = a_n p^n + a_{n-1} p^{n-1} + \dots + a_1 p + a_0$$

and

$$N(p) = b_m p^m + b_{m-1} p^{m-1} + \dots + b_1 p + b_0$$

Where the variable p is the differentiator d/dt defined by

$$p y(t) = \frac{d}{dt} y(t) \quad p^2 y(t) = \frac{d^2}{dt^2} y(t) \quad p^3 y(t) = \frac{d^3}{dt^3} y(t)$$

and so forth. This can be written as

$$D(p)y(t) = N(p)u(t)$$

In the study of the zero-input response, we assume $u(t) = 0$. Then reduces to

$$D(p)y(t) = 0$$

This is the homogeneous equation. Its solution is excited exclusively by initial conditions. The application of the Laplace transform yields, as in,

$$Y(s) = \frac{I(s)}{D(s)}$$

We call $D(s)$ the characteristic polynomial ,The roots of the polynomial $D(s)$ are called the modes. For example, if

$$D(s) = (s - 2)(s + 1)^2(s + 2 - 3i)(s + 2 + 3i)$$

Then the modes are $2, -1, -1, -2 + 3i$, and $-2 - 3i$. The root 2 and the complex roots $-2 \pm 3i$ are simple modes and the root -1 is a repeated mode with multiplicity 2. Thus for any initial conditions, $Y(s)$ can be expanded as

$$Y(s) = \frac{k_1}{s - 2} + \frac{k_2}{s + 2 - j3} + \frac{k_3}{s + 2 + j3} + \frac{c_1}{s + 1} + \frac{c_2}{(s + 1)^2}$$

and its zero-input response is,

$$Y(t) = k_1 e^{2t} + k_2 e^{-(2-j3)t} + k_3 e^{-(2+j3)t} + c_1 e^{-t} + c_2 t e^{-t}$$

This is the general form of the zero-input response and is determined by the modes of the system.

Example 4-4

Consider the system shown in Figure. If

$$G(s) = \frac{8}{(s + 1)(s^2 + 2s + 2)}$$

Then the transfer function from r to y is

$$G_0(s) = \frac{8K}{(s + 1)(s^2 + 2s + 2) + 8K} = \frac{8K}{s^3 + 3s^2 + 4s + (8K + 2)}$$

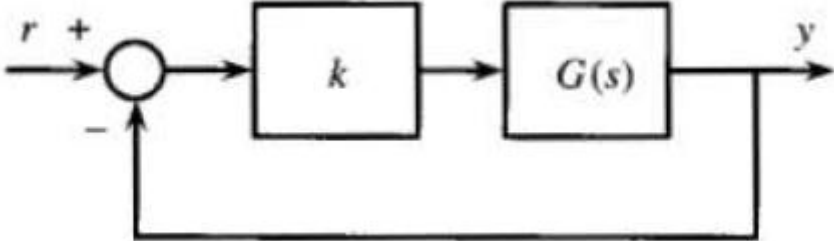

Figure 4-8 unity-feedback system

We form the Routh table for its denominator:

s^3	1	5
s^2	3	K_p
s^1	$\frac{01 - 8K}{3}$	
s^0	$2 + 8K$	

The conditions for $G_0(s)$ to be stable are

$$\frac{10 - 8K}{3} > 0 \quad \text{and} \quad 2 + 8K > 0$$

These two inequalities imply

$$1.25 = \frac{10}{3} > K \quad \text{and} \quad K > \frac{-2}{8} = -0.25$$

They are plotted in Figure (a) From the plot we see that $1.25 > K > -0.25$, then k meets both inequalities, and the system is stable.

Steady-State Response of Stable Systems-Sinusoidal Inputs

Consider a system with proper transfer function $G_0(s) = Y(s)/R(s)$. It is assumed that $G_0(s)$ is stable. Now we shall show that if $r(t) = a \sin \omega_0 t$, then the output $y(t)$ will approach a sinusoidal function with the same frequency as $t \rightarrow \infty$ If $r(t) = a \sin \omega_0 t$ then

$$R(s) = \frac{a\omega_0}{s^2 + \omega_0^2}$$

Hence, we have

$$Y(s) = G_0(s)R(s) = G_0(s) \cdot \frac{a\omega_0}{s^2 + \omega_0^2} = G_0(s) \cdot \frac{a\omega_0}{(s + i\omega_0)(s - i\omega_0)}$$

Because $G_0(s)$ is stable, $s = \pm i\omega_0$ are simple poles of $Y(s)$. Thus $Y(s)$ can be expanded as, using partial fraction expansion,

$$Y(s) = \frac{K_1}{(s - i\omega_0)} + \frac{K_1^*}{(s + i\omega_0)} + \text{terms due to the poles of } G_0(s)$$

With

$$K_1 = G_0(s) \cdot \frac{a\omega_0}{s + i\omega_0} \Big|_{s \rightarrow i\omega_0} = G_0(i\omega_0) \cdot \frac{a\omega_0}{2i\omega_0} = \frac{a}{2i} G_0(i\omega_0)$$

And

$$K_1^* = \frac{a}{-2i} G_0(-i\omega_0)$$

Since all the poles of $G_0(s)$ have negative real parts, their time responses will approach zero as $t \rightarrow \infty$ Hence, the steady-state response of the system due to $r(t) = a \sin \omega_0 t$ is given by

$$y_s(t) = L^{-1} \left[\frac{aG_0(i\omega_0)}{2i(s - i\omega_0)} - \frac{aG_0(-i\omega_0)}{2i(s + i\omega_0)} \right]$$

All coefficients of $G_0(s)$ are implicitly assumed to be real. Even so, the function $G_0(i\omega_0)$ is generally complex. We express it in polar form as

$$G_0(i\omega_0) = A(\omega_0)e^{i\theta(\omega_0)}$$

Where

$$A(\omega_0) = |G_0(i\omega_0)| = \left[(\operatorname{Re}G_0(i\omega_0))^2 + (\operatorname{Im}G_0(i\omega_0))^2 \right]^{1/2}$$

And

$$\theta(\omega_0) = \angle G_0(i\omega_0) = \tan^{-1} \frac{\operatorname{Im}G_0(i\omega_0)}{\operatorname{Re}G_0(i\omega_0)}$$

Where Im and Re denote, respectively, the imaginary and real parts. $A(\omega_0)$ is called the amplitude and $\theta(\omega_0)$, the phase of $G_0(s)$. If all coefficients of $G_0(s)$ are real, then $A(\omega_0)$ is an even function of ω_0 , and $\theta(\omega_0)$ is an odd function of ω_0 ; that is, $A(-\omega_0) = A(\omega_0)$ and $\theta(-\omega_0) = -\theta(\omega_0)$. Consequently we have

$$G_0(-i\omega_0) = A(-\omega_0)e^{i\theta(-\omega_0)} = A(\omega_0)e^{-i\theta(\omega_0)}$$

The substitution of () and () into () yields

$$\begin{aligned} y_s(t) &= \frac{aA(\omega_0)e^{i\theta(\omega_0)}}{2i} \cdot e^{i\omega_0 t} - \frac{aA(\omega_0)e^{-i\theta(\omega_0)}}{2i} \cdot e^{-i\omega_0 t} \\ &= aA(\omega_0) \frac{e^{i[\omega_0 t + \theta(\omega_0)]} - e^{-i[\omega_0 t + \theta(\omega_0)]}}{2i} \\ &= aA(\omega_0) \sin(\omega_0 t + \theta(\omega_0)) \end{aligned}$$

This shows that if $r(t) = a \sin \omega_0 t$, then the output will approach a sinusoidal function of the same frequency. Its amplitude equals $|G_0(i\omega_0)|$, its phase differs from the phase of the input by $\tan^{-1} \frac{\operatorname{Im}G_0(i\omega_0)}{\operatorname{Re}G_0(i\omega_0)}$.

The steady-state response of a stable $G_0(s)$ due to $\sin \omega_0 t$ is completely determined by the value of $G_0(s)$ at $s = i\omega_0$. Thus $G_0(i\omega_0)$ is called the frequency response of the system. Its amplitude $A(i\omega_0)$ is called the amplitude characteristic. For example, if $G_0(s) = 2/(s + 1)$, then $G_0(0) = 2$, $G_0(i1) = 2/(i1 + 1) = 2/(1.4e^{i45^\circ}) = 1.4e^{-i45^\circ}$, $G_0(j10) = 2/(i10 + 1) = 0.2e^{-i84^\circ}$ and so forth. The

amplitude and phase characteristics of $G_0(s) = 2/(s + 1)$ can be plotted as shown in Figure 4-9. From the plot, the steady-state response due to $\sin \omega_0 t$, for any ω_0 .

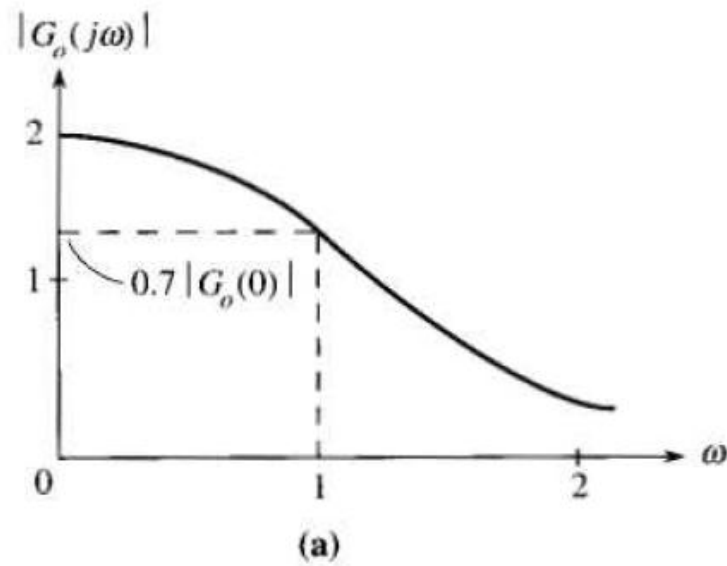

Figure 4-9 Amplitude and phase characteristics

Example 4-5

Consider $G_0(s) = 3/(s + 0.4)$. It is stable. In order to compute its steady-state response due to $r(t) = \sin 2t$, we compute

$$G_0(i2) = \frac{3}{(i2 + 0.4)} = \frac{3}{2.04e^{i1.37}} = 1.47e^{-i1.37}$$

Thus the steady-state response is

$$y_s(t) = \lim_{t \rightarrow \infty} y(t) = 1.47 \sin(2t - 1.37)$$

Note that the phase -1.37 is in radians, not in degrees. This computation is very simple, but it does not reveal how fast the system will approach the steady state.

Example 4-6

Consider $G(s) = 1/(s + 1)^3$. It has three poles at $s = -1$. The time constant of $G(s)$ is 1 second. The unit-step response of $G(s)$ is

$$Y(s) = \frac{1}{(s + 1)^3} \cdot \frac{1}{s} = \frac{1}{s} + \frac{-1}{(s + 1)^3} + \frac{-1}{(s + 1)^2} + \frac{-1}{(s + 1)}$$

or

$$y(t) = 1 - 0.5t^2 e^{-t} - t e^{-t} - e^{-t}$$

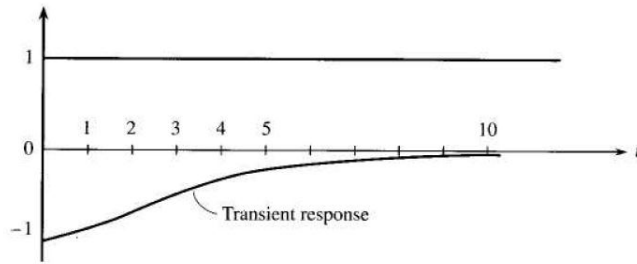

Figure 4-10 Step response

Its steady-state response is 1 and its transient response is

$$-0.5t^2e^{-t} - te^{-t} - e^{-t} = -(0.5t^2 + t + 1)e^{-t}$$

These are plotted in Figure above. At five time constants, or $t = 5$, the value of the transient response is -0.126 ; it is about 13% of the steady-state response. At $t = 9$, the value of the transient response is 0.007 or 0.7% of the steady-state response. For this system, it is more appropriate to claim that the response reaches the steady state in nine time constants.

Poles and Zeros

The zero-state response of a system is governed by its transfer function. Before computing the response, we introduce the concepts of poles and zeros. Consider a proper rational transfer function

$$G(s) = \frac{N(s)}{D(s)}$$

Where $N(s)$ and $D(s)$ are polynomials with real coefficients.

Example 4-7

Consider the transfer function

$$G(s) = \frac{N(s)}{D(s)} = \frac{2(s^3 + 3s^2 - s - 3)}{(s - 1)(s + 2)(s + 1)^3}$$

We have

$$G(-2) = \frac{N(-2)}{D(-2)} = \frac{2((-2)^3 + 3(-2)^2 + (-2) - 3)}{(-3) \cdot 0 \cdot (-1)} = \frac{6}{0} = \infty$$

Therefore -2 is a pole of $G(s)$. Clearly -2 is a root of $D(s)$.

Does this imply every root of $D(s)$ is a pole of $G(s)$.

$$G(1) = \frac{N(1)}{D(1)} = \frac{2(1+3-1-3)}{0.3.8} = \frac{0}{0}$$

It is not defined. However l'Hopital's rule implies

$$\begin{aligned} G(1) &= \left. \frac{N(s)}{D(s)} \right|_{s=1} = \left. \frac{N'(s)}{D'(s)} \right|_{s=1} \\ &= \left. \frac{2(3s^2 + 6s - 1)}{5s^4 + 16s^3 + 12s^2 - 4s - 5} \right|_{s=1} = \frac{16}{24} \neq \infty \end{aligned}$$

Thus $s = 1$ is not a pole of $G(s)$. Therefore not every root of $D(s)$ is a pole of $G(s)$. Now we factor $N(s)$ and then cancel the common factors between $N(s)$ and $D(s)$ to yield

$$G(s) = \frac{N(s)}{D(s)} = \frac{2(s+3)(s-1)(s+1)}{(s-1)(s+2)(s+1)^3} = \frac{2(s+1)}{(s+2)(s+1)^2}$$

We see immediately that $s = 1$ is not a pole of $G(s)$. Clearly $G(s)$ has one zero, -3 .

We now discuss the computation of the zero-state response. The zero-state response of a system is governed by $Y(s) = G(s)U(s)$. To compute $Y(s)$, we first compute the Laplace transform of $u(t)$. We then multiply $G(s)$ and $U(s)$ to yield $Y(s)$. The inverse Laplace transform of $Y(s)$ yields the zero-state response. This is illustrated by an example.

Example 4-8

Find the zero-state response of due to $u(t) = 1$, for $t \geq 0$. This is called the unit-step response. The Laplace transform of $u(t)$ is $1/s$. Thus we have

$$Y(s) = G(s)U(s) = \frac{3s-1}{(s+1)(s+2)} \cdot \frac{1}{s}$$

To compute its inverse Laplace transform, we carry out the partial fraction expansion

$$Y(s) = \frac{3s-1}{(s+1)(s+2)s} = \frac{K_1}{s+1} + \frac{K_2}{s+2} + \frac{K_3}{s}$$

Where

$$K_1 = Y(s) \cdot (s+1) \Big|_{s=-1} = \frac{3s-1}{(s+2)s} \Big|_{s=-1} = \frac{-4}{(1)(-1)} = 4$$

$$K_2 = Y(s) \cdot s + 2 \Big|_{s=-2} = \frac{3s-1}{(s+2)s} \Big|_{s=-2} = \frac{-7}{(-1)(-2)} = -3.5$$

$$K_3 = Y(s) \cdot s \Big|_{s=0} = \frac{3s-1}{(s+1)(s+2)} \Big|_{s=0} = \frac{-1}{2} = -0.5$$

The zero-state response is

$$y(t) = 4e^{-t} - 3.5e^{-2t} - 0.5$$

for $t \geq 0$. Thus, the use of the Laplace transform to compute the zero-state response is simple and straightforward.

This example reveals an important fact of the zero-state response. We see that the response consists of three terms. Two are the inverse Laplace transforms of $1/(s+2)$ and $1/(s+1)$, which are the poles of the system. The remaining term is due to the step input. In fact, for any $u(t)$, the response is generally of the form

$$y(t) = K_1 e^{-t} + K_2 e^{-2t} + (\text{terms due to the poles of } U(s))$$

Thus the poles of $G(s)$ determine the basic form of the zero state response.

Example 4-9

Consider the system

$$Y(s) = G(s)U(s) = \frac{3s-1}{(s+1)(s+2)} \cdot \frac{1}{s}$$

Find a bounded input $u(t)$ so that the pole -1 will not be excited. If

$$U(s) = s + 1, \text{ then}$$

$$\begin{aligned} Y(s) &= G(s)U(s) = \frac{3s-1}{(s+1)(s+2)} \cdot (s+1) \\ &= \frac{3s-1}{s+2} = \frac{3(s+2)-7}{s+2} = 3 - \frac{7}{s+2} \end{aligned}$$

Which implies

$$y(t) = 3\delta - 7e^{-2t}$$

This response does not contain e^{-t} , thus the pole -1 is not excited. Therefore if we introduce a zero in $U(s)$ to cancel a pole, then the pole will not be excited by the input $u(t)$. If $U(s)$ is biproper or improper, as is the case for $U(s) = s + 1$, then its inverse Laplace transform $u(t)$ will contain an impulse and its derivatives and is not bounded. In order for $u(t)$ to be bounded, we choose, rather arbitrarily, $U(s) =$

$(s + 1)/s(s + 3)$, a strictly proper rational function . Its inverse Laplace transform is

$$u(t) = \frac{1}{3} + \frac{2}{3}e^{-3t}$$

For $t \geq 0$ and is bounded .The application of this input yields

$$\begin{aligned} Y(s) &= \frac{3s - 1}{(s + 2)(s + 1)} \cdot \frac{(s + 1)}{s(s + 3)} = \frac{3s - 1}{(s + 2)(s + 3)s} \\ &= \frac{7}{2(s + 2)} - \frac{10}{3(s + 3)} - \frac{1}{6s} \end{aligned}$$

Which implies

$$y(t) = \frac{7}{2}e^{-2t} - \frac{10}{3}e^{-3t} - \frac{1}{6}$$

for $t > 0$. The second and third terms are due to the input, the first term is due to the pole -2 .The term e^{-1} does not appear in $y(t)$,thus the pole -1 is not excited by the input. We shall show here that by use of the zero-placement approach presented later in this Chapter we can achieve the following:

The responses to the ramp reference input and acceleration reference input exhibit no steady-state errors. In high-performance control systems it is always desired that the system output follow the changing input with minimum error. For step, ramp, and acceleration inputs, it is desired that the system output exhibit no steady-state error. In what follows, we shall demonstrate how to design control systems that will exhibit no steady-state errors in following ramp and acceleration inputs and at the same time force the response to the step disturbance input to approach zero quickly. Assume that the plant transfer function $G_p(s)$ is a minimum-phase transfer function and is given by

$$G_p = K \frac{A(s)}{B(s)}$$

where

$$\begin{aligned} A(s) &= (s + z_1)(s + z_2) \dots \dots (s + z_m) \\ B(s) &= s^N (s + p_{N+1})(s + p_{N+2}) \dots \dots (s + p_n) \end{aligned}$$

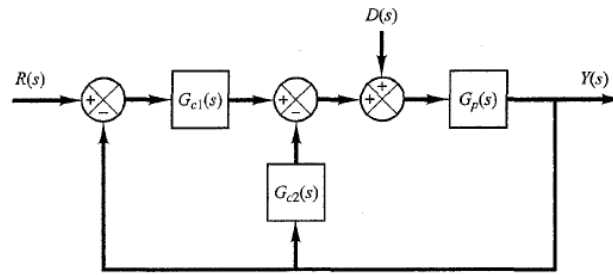

Figure 4-11 control system

Where N may be 0, 1, 2 and $n \geq m$. Assume also that G_{c1} is a PID controller followed by a filter $1/A(s)$, or

$$G_{c1}(s) = \frac{\alpha_1 s + \beta_1 + \gamma_1 s^2}{s} \frac{1}{A(s)}$$

and G_{c2} is a PID, PI, PD, I,D, or P controller followed by a filter $1/A(s)$. That

$$G_{c2}(s) = \frac{\alpha_2 s + \beta_2 + \gamma_2 s^2}{s} \frac{1}{A(s)}$$

where some of α , β and γ may be zero. Then it is possible to write $G_{c1} + G_{c2}$

$$G_{c1} + G_{c2} = \frac{\alpha s + \beta + \gamma s^2}{s} \frac{1}{A(s)}$$

where α, β and γ are constants. Then

$$\begin{aligned} \frac{Y(s)}{D(s)} &= \frac{G_p}{1 + (G_{c1} + G_{c2})G_p} = \frac{K \frac{A(s)}{B(s)}}{1 + \frac{\alpha s + \beta + \gamma s^2}{s} \frac{K}{B(s)}} \\ &= \frac{sKA(s)}{sB(s) + (\alpha s + \beta + \gamma s^2)K} \end{aligned}$$

Because of the presence of s in the numerator, the response $y(t)$ to a step disturbance input approaches zero as t approaches infinity, as shown below. Since

$$Y(s) = \frac{sKA(s)}{sB(s) + (\alpha s + \beta + \gamma s^2)K} D(s)$$

if the disturbance input is a step function of magnitude d , or

$$D(s) = \frac{d}{s}$$

and assuming the system is stable, then

$$y(\infty) = \lim_{s \rightarrow 0} \left[\frac{sKA(s)}{sB(s) + (\alpha s + \beta + \gamma s^2)K} \right] \frac{d}{s}$$

$$\lim_{s \rightarrow 0} \frac{s KA(0)d}{sB(0) + \beta K} = 0$$

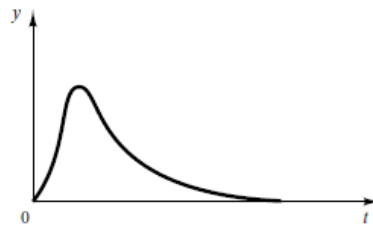

Figure 4-12 step disturbance input

The response $y(t)$ to a step disturbance input will have the general form shown in Figure a bove. Note that $Y(s)/R(s)$ and $Y(s)/D(s)$ are given by

$$\frac{Y(s)}{R(s)} = \frac{G_{c1}G_p}{1 + (G_{c1} + G_{c2})G_p} \quad , \quad \frac{Y(s)}{D(s)} = \frac{G_p}{1 + (G_{c1} + G_{c2})G_p}$$

Notice that the denominators of $Y(s)/R(s)$ and $Y(s)/D(s)$ are the same. Before we choose the poles of $Y(s)/R(s)$, we need to place the zeros of $Y(s)/R(s)$.

Zero Placement

Consider the system

$$\frac{Y(s)}{R(s)} = \frac{p(s)}{s^{n+1} + a_n s^n + a_{n-1} s^{n-1} + \dots + a_2 s^2 + a_1 s + a_0}$$

If we choose $p(s)$ as

$$p(s) = a_2 s^2 + a_1 s + a_0 = a_2 (s + s_1)(s + s_2)$$

that is, choose the zeros $s = -s_1$ and $s = -s_2$ such that, together with a_2 , the numerator polynomial $p(s)$ is equal to the sum of the last three terms of the

denominator polynomial then the system will exhibit no steady-state errors in response to the step input, ramp input, and acceleration input.

Requirement Placed on System Response Characteristics

Suppose that it is desired that the maximum overshoot in the response to the unit-step reference input be between arbitrarily selected upper and lower limits for example, $2\% < \text{maximum overshoot} < 10\%$ where we choose the lower limit to be slightly above zero to avoid having over damped systems. The smaller the upper limit, the harder it is to determine the coefficient a's. In some cases, no combination of the a's may exist to satisfy the specification, so we must allow a higher upper limit for the maximum overshoot. We use MATLAB to search at least one set of the a's to satisfy the specification. As a practical computational matter, instead of searching for the a's, we try to obtain acceptable closed-loop poles by searching a reasonable region in the left-half s plane for each closed-loop pole. Once we determine all closed-loop poles, then all coefficients a_{n-1}, a_1, a_0 will be determined.

Determination of G_{c2}

Now that the coefficients of the transfer function $Y(s)/R(s)$ are all known and $Y(s)/R(s)$ is given by

$$\frac{Y(s)}{R(s)} = \frac{a_2s^2 + a_1s + a_0}{s^{n+1} + a_n s^n + a_{n-1} s^{n-1} + \dots + a_2 s^2 + a_1 s + a_0}$$

$$\begin{aligned} \frac{Y(s)}{R(s)} &= G_{c1} \frac{Y(s)}{D(s)} \\ &= \frac{G_{c1} s K A(s)}{s B(s) + (\alpha s + \beta + \gamma s^2) K} \\ &= \frac{G_{c1} s K A(s)}{s^{n+1} + a_n s^n + a_{n-1} s^{n-1} + \dots + a_2 s^2 + a_1 s + a_0} \end{aligned}$$

Since G_{c1} is a PID controller and is given by

$$G_{c1} = \frac{\alpha_1 s + \beta_1 + \gamma_1 s^2}{s} \frac{1}{A(s)}$$

$Y(s)/R(s)$ can be written as

$$\frac{Y(s)}{R(s)} = \frac{K(\alpha_1 s + \beta_1 + \gamma_1 s^2)}{s^{n+1} + a_n s^n + a_{n-1} s^{n-1} + \dots + a_2 s^2 + a_1 s + a_0}$$

Therefore, we choose

$$K\gamma_1 = a_2, \quad K\alpha_1 = a_1, \quad K\beta_1 = a_0$$

so that

$$G_{c1} = \frac{a_1 s + a_0 + a_2 s^2}{Ks} \frac{1}{A(s)}$$

The response of this system to the unit-step reference input can be made to exhibit the maximum overshoot between the chosen upper and lower limits, such as $2\% < \text{maximum overshoot} < 10\%$.

The response of the system to the ramp reference input or acceleration reference input can be made to exhibit no steady-state error. If we wish to further shorten the settling time, then we need to allow a larger maximum overshoot for example, $2\% < \text{maximum overshoot} < 20\%$. The controller G_{c2} can now be determined

$$G_{c1} + G_{c2} = \frac{\alpha s + \beta + \gamma s^2}{s} \frac{1}{A(s)}$$

we have

$$\begin{aligned} G_{c2} &= \left[\frac{\alpha s + \beta + \gamma s^2}{s} - \frac{a_1 s + a_0 + a_2 s^2}{Ks} \right] \frac{1}{A(s)} \\ &= \frac{(K\alpha - a_1)s + (K\beta - a_0) + (K\gamma - a_2)s^2}{Ks} \frac{1}{A(s)} \end{aligned}$$

Steady-State Errors

Consider the system shown in Figure 4-13. The closed-loop transfer function is

$$\frac{C(s)}{R(s)} = \frac{G(s)}{1 + G(s)}$$

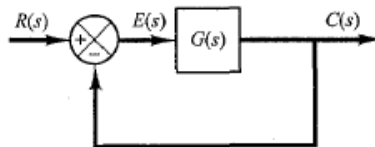

Figure 4-13 Control system

The transfer function between the error signal $e(t)$ and the input signal $r(t)$

$$\frac{E(s)}{R(s)} = 1 - \frac{C(s)}{R(s)} = \frac{1}{1+G(s)}$$

Where the error $e(t)$ is the difference between the input signal and the output signal. The final-value theorem provides a convenient way to find the steady-state performance of a stable system.

Since $E(s)$ is

$$E(s) = \frac{1}{1 + G(s)} R(s)$$

The steady-state error is

$$e_{ss} = \lim_{t \rightarrow \infty} e(t) = \lim_{s \rightarrow 0} sE(s) = \lim_{s \rightarrow 0} \frac{sR(s)}{1 + G(s)}$$

The static error constants defined in the following are figures of merit of control systems. The higher the constants, the smaller the steady-state error. In a given system, the output may be the position, velocity, pressure, temperature, or the like. The physical form of the output, however, is immaterial to the present analysis. Therefore, in what follows, we shall call the output position, the rate of change of the output "velocity," and so on. This means that in a temperature control system "position" represents the output temperature, "velocity" represents the rate of change of the output temperature, and so on.

Static Position Error Constant k_p

The steady-state error of the system for a unit-step input is

$$\begin{aligned} e_{ss} &= \lim_{s \rightarrow 0} \frac{s}{1 + G(s)} \frac{1}{s} \\ &= \frac{1}{1 + G(0)} \end{aligned}$$

The static position error constant K_p is defined by

$$k_p = \lim_{s \rightarrow 0} G(s) = G(0)$$

Thus, the steady-state error in terms of the static position error constant K , is given by

$$e_{ss} = \frac{1}{1 + k_p}$$

For a type 0 system, $K_p = \lim_{s \rightarrow 0} G(s) = \frac{K(T_a s + 1)(T_b + 1) \dots}{(T_1 s + 1)(T_2 + 1) \dots}$

For a type 1 or higher system

$$G(s) = \frac{K(T_a s + 1)(T_b + 1) \dots}{S^N (T_1 s + 1)(T_2 + 1) \dots} = \infty$$

Hence, for a type 0 system, the static position error constant K_p is finite, while for a type 1 or higher system, K_p is infinite.

For a unit-step input, the steady-state error e_{ss} may be summarized as follows:

$$e_{ss} = \frac{1}{1+k} \text{ for type 0 systems}$$

$$e_{ss} = 0 \text{ for type 1 or higher system}$$

From the foregoing analysis, it is seen that the response of a feedback control system to a step input involves a steady-state error if there is no integration in the feed forward path. (If small errors for step inputs can be tolerated, then a type 0 system may be permissible, provided that the gain K is sufficiently large. If the gain K is too large, however, it is difficult to obtain reasonable relative stability.) If zero steady-state error for a step input is desired, the type of the system must be one or higher.

Static Velocity Error Constant K_v

The steady-state error of the system with a unit-ramp input is given by

$$\begin{aligned} e_{ss} &= \lim_{s \rightarrow 0} \frac{s}{1 + G(s)} \frac{1}{s^2} \\ &= \lim_{s \rightarrow 0} \frac{1}{sG(s)} \end{aligned}$$

The static velocity error constant K_v is defined by

$$K_v = \lim_{s \rightarrow 0} sG(s)$$

Thus, the steady-state error in terms of the static velocity error constant K_v is given by

$$e_{ss} = \frac{1}{K_v}$$

$$K_v = \lim_{s \rightarrow 0} \frac{s k (T_a s + 1)(T_b + 1) \dots}{(T_1 s + 1)(T_2 + 1) \dots} = 0$$

For a type 1 system,

$$K_v = \lim_{s \rightarrow 0} \frac{s k (T_a s + 1)(T_b + 1) \dots}{s(T_1 s + 1)(T_2 + 1) \dots} = k$$

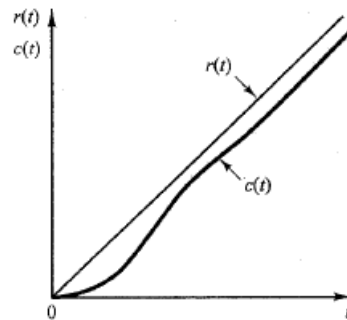

Figure 4-14 Response of a type 1 unity-feedback system to a ramp input.

For a type 2 or higher system

$$K_v = \lim_{s \rightarrow 0} \frac{s k (T_a s + 1)(T_b + 1) \dots}{s^N (T_1 s + 1)(T_2 + 1) \dots} = \infty$$

The steady-state error e_{ss} for the unit-ramp input can be summarized as follows

$$e_{ss} = \frac{1}{K_v} = \infty$$

$$e_{ss} = \frac{1}{K_v} = \frac{1}{K}$$

$$e_{ss} = \frac{1}{K_v} = 0$$

Static Acceleration Error Constant K_a

The steady-state error of the system with a unit-parabolic input (acceleration input), which is defined by

$$r(t) = \frac{t^2}{2} \quad \text{for } t \geq 0$$

$$= 0 \quad \text{for } t < 0$$

$$e_{ss} = \lim_{s \rightarrow 0} \frac{s}{1 + G(s)} \frac{1}{s^3}$$

$$= \frac{1}{\lim_{s \rightarrow 0} s^2 G(s)}$$

The static acceleration error constant K_a is defined by the equation

$$K_a = \lim_{s \rightarrow 0} s^2 G(s)$$

The steady-state error is the

$$e_{ss} = \frac{1}{K_a}$$

Note that the acceleration error, the steady-state error due to a parabolic input, is an error in position. The values of K_a are obtained as follows:

For a type 0 system

$$K_a = \lim_{s \rightarrow 0} \frac{s^2 k (T_a s + 1)(T_b + 1) \dots}{(T_1 s + 1)(T_2 + 1) \dots} = 0$$

For a type 1 system,

$$K_a = \lim_{s \rightarrow 0} \frac{s^2 k (T_a s + 1)(T_b + 1) \dots}{s(T_1 s + 1)(T_2 + 1) \dots} = 0$$

For a type 2 system,

$$K_a = \lim_{s \rightarrow 0} \frac{s^2 k (T_a s + 1)(T_b + 1) \dots}{s^2 (T_1 s + 1)(T_2 + 1) \dots} = k$$

For a type 3 or higher system,

$$K_a = \lim_{s \rightarrow 0} \frac{s k (T_a s + 1)(T_b + 1) \dots}{s^N (T_1 s + 1)(T_2 + 1) \dots} = \infty$$

Thus, the steady-state error for the unit parabolic input is

$$e_{ss} = \frac{1}{K_a}$$

Note that both type 0 and type 1 systems are incapable of following a parabolic input in the steady state. The type 2 system with unity feedback can follow a parabolic input with a finite error signal.

Chapter 5

PID controller Design

5-1 Introduction

This chapter describes methods for finding parameters of a PID controller which is a special case of the problem of control system design that was discussed in this Chapter. Design of PID controllers differs from the general design problem because the controller complexity is restricted. The general design methods give a controller with a complexity that matches the process model. To obtain a controller with restricted complexity we can either simplify the process models so that the design gives a PID controller, or we can design a controller for a complex model and approximate it with a PID controller. Another reason why special design methods for PID controllers emerged is the desire to have simple design methods that can be used by persons with poor knowledge of control. The situation has changed substantially with the advent of tuning tools and automatic tuners, which have made it possible to improve the process knowledge's and permitted the use of more extensive calculations. This has brought design of PID controllers closer to the mainstream of control systems design.

5-2 Root Locus analysis

The **root locus** method provides a quick means of predicting the closed-loop behavior of a system based on its open-loop poles and zeros. The method is based on the properties of the closed-loop characteristic equation

$$1 + KL = 0 \quad (5 - 1)$$

Where the gain K is a design parameter and $L(s)$ is the loop gain of the system.

We assume a loop gain of the form

$$L(s) = \frac{\prod_{i=1}^{n_z} (s - z_i)}{\prod_{j=1}^{n_p} (s + p_j)} \quad (5 - 2)$$

Where $z_i, i = 1, 2, \dots, n_z$, are the open-loop system zeros and p_j

$j = 1, 2, \dots, n_p$ are the open-loop system poles. It is required to determine the loci of the closed loop poles of the system (root loci) as K varies between zero and infinity.¹ Because of the relationship between pole locations and the time response, this gives preview of the closed-loop system behavior for different K .

The complex equality is equivalent to the two real equalities

1- Magnitude condition $K|L(s)| = 1$

2- Angle condition $\angle L(s) = \pm(2m + 1)180^\circ, m = 0, 1, 2, \dots$

Using the preceding conditions, the following rules for sketching root loci can be derived:

3- The number of root locus branches is equal to the number of open-loop poles of $L(s)$.

4- The root locus branches start at the open-loop poles and end at the open loop zeros or at infinity.

5- The real axis root loci have an odd number of poles plus zeros to their right.

6- The branches going to infinity asymptotically approach the straight lines defined by the angle

$$\theta_a = \frac{\pm(2m + 1)180^\circ}{n_p - n_z}, m = 0, 1, 2, \dots \quad (5 - 3)$$

and the intercept

$$\sigma_a = \frac{\sum_{i=1}^{n_p} P_i - \sum_{j=1}^{n_z} Z_j}{n_p - n_z}$$

7- Breakaway points (points of departure from the real axis) correspond to local maxima of K , whereas break-in points (points of arrival at the real axis) correspond to local minima of K .

8- The angle of departure from a complex pole p_n is given by

$$180 - \sum_{i=1}^{n_p-1} \angle(P_n - P_i) + \sum_{j=1}^{n_z} \angle(P_n - Z_j) \quad (5 - 4)$$

The angle of arrival at a complex zero is similarly defined.

Example 5.1

Sketch the root locus plots for the loop gains

$$L(s) = \frac{1}{(s + 1)(s + 3)}$$

$$L(s) = \frac{1}{(s + 1)(s + 3)(s + 5)}$$

$$L(s) = \frac{s + 5}{(s + 1)(s + 3)}$$

Comment on the effect of adding a pole or a zero to the loop gain.

Solution

The root loci for the three loop gains as obtained using MATLAB are shown in blue. We now discuss how these plots can be sketched using root locus sketching rules.

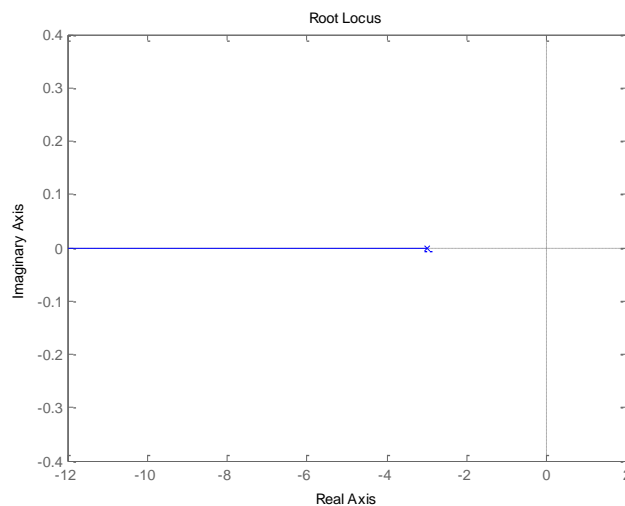
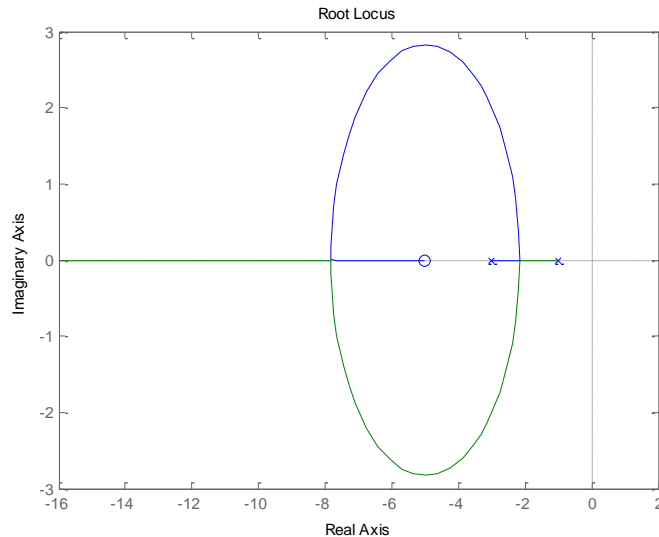

Figure 5-1 Root locus for three loop gain



1- Using rule 1, the function has two root locus branches. By rule 2, the branches start at -1 and -3 and go to infinity. By rule 3, the real axis locus is between (-1) and (-3) . Rule 4 gives the asymptote angles and the intercept. To find the breakaway point using Rule 5, we express real K using the characteristic equation as we then differentiate with respect to s and equate to zero for a maximum to obtain

$$\theta_a = \frac{\pm(2m + 1)180^\circ}{n_p - n_z} \quad m = 0,1,2, \dots$$

$$= \pm 90, \pm 270$$

and the intercept $\sigma_a = \frac{-1-3}{2} = -2$

To find the breakaway point using Rule 5, we express real K using the characteristic equation as

$$K = -(\sigma + 1)(\sigma + 3) = -(\sigma^2 + 4\sigma + 3)$$

We then differentiate with respect to σ and equate to zero for a maximum to obtain

$$-\frac{dK}{d\sigma} = 2\sigma + 4 = 0$$

Hence, the breakaway point is at $\sigma_b = 2$. This corresponds to a maximum of K because the second derivative is equal to -2 (negative). It can be easily shown

that for any system with only two real axis poles, the breakaway point is midway between the two poles.

2. The root locus has three branches, with each branch starting at one of the open-loop poles $(-1, -3, -5)$. The real axis loci are between -1 and -3 and to the left of -5 . The branches all go to infinity, with one branch remaining on the negative real axis and the other two breaking away. The breakaway point is given by the maximum of the real gain K . Differentiating gives which yields $\sigma_b = -1.845$ or -4.155 . The first value is the actual breakaway point because it lies on the real axis locus between the poles and -1 and -3 . The second value corresponds to a negative gain value and is therefore inadmissible. The gain at the breakaway point can be evaluated from the magnitude condition and is given by

$$K = -(-1.845 + 1)(-1.845 + 3)(-1.845 + 5) = 3.079$$

The asymptotes are defined by the angles

$$\theta_a = \frac{\pm(2m + 1)180^\circ}{n_p - n_z} \quad m = 0, 1, 2, \dots$$

and the intercept $\sigma_a = \frac{-1-3-5}{3} = -3$

The closed-loop characteristic equation corresponds to the Routh table

s^3	1	23
s^2	9	$15 + K$
s^1	$\frac{192 - K}{9}$	
s^0	$15 + K$	

Thus, at $K = 192$, a zero row results. This value defines the auxiliary equation

$$9s^2 + 270 = 0$$

Thus, the intersection with the $i\omega$ -axis is $\pm i4.796$ rad/s.

3. The root locus has two branches as in (1), but now one of the branches ends at the zero. From the characteristic equation, the gain is given by

$$K = -\frac{(\sigma + 1)(\sigma + 3)}{\sigma + 5}$$

Differentiating gives

$$\begin{aligned}\frac{dK}{d\sigma} &= -\frac{(\sigma + 1 + \sigma + 3)(\sigma + 5) - (\sigma + 1)(\sigma + 3)}{(\sigma + 5)^2} \\ &= -\frac{\sigma^2 + 10\sigma + 17}{(\sigma + 5)^2} \\ &= 0\end{aligned}$$

Which yields $\sigma_b = -2.172$ or -7.828 . the first value is the breakaway point because it lies between the poles, whereas the second value is to the left of the zero and corresponds to the break-in point. The second derivative

$$\begin{aligned}\frac{d^2K}{d\sigma^2} &= -\frac{(2\sigma + 10)(\sigma + 5) - 2(\sigma^2 + 10\sigma + 17)}{(\sigma + 5)^3} \\ &= \frac{-16}{(\sigma + 5)^3}\end{aligned}$$

5-3 Root Locus Using MATLAB

While the above rules together allow the sketching of root loci for any loop gain, it is often sufficient to use a subset of these rules to obtain the root loci. For higher-order or more complex situations, it is easier to use a CAD tool like MATLAB. These packages do not actually use root locus sketching rules. Instead they numerically solve for the roots of the characteristic equations K is varied in a given range and then display the root loci. The MATLAB command to obtain root locus plots is “rlocus”.

Example 5-2

Obtain the root locus of the system

$$G(s) = \frac{s + 5}{s^2 + 2s + 10} \quad (5 - 5)$$

using MATLAB enter

```
>> g = tf ([1, 5], [1, 2, 10]);
>> rlocus (g);
```

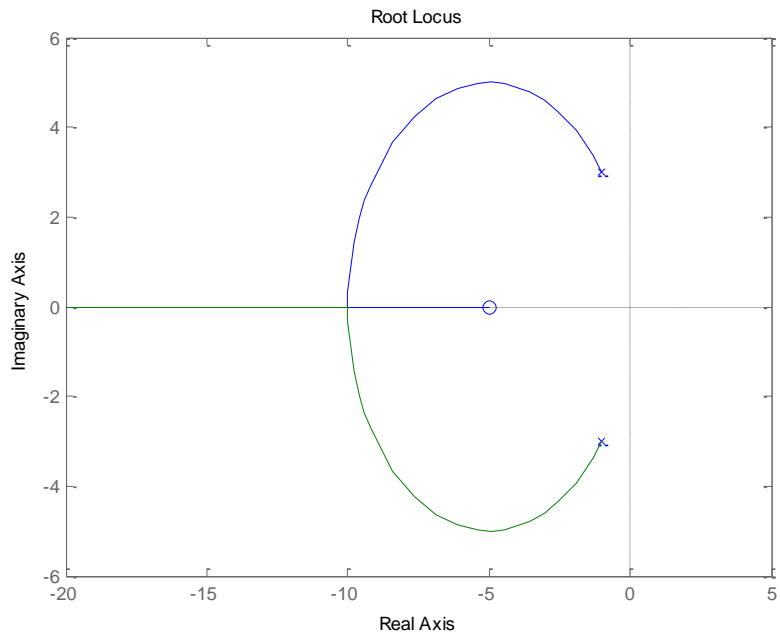

Root locus

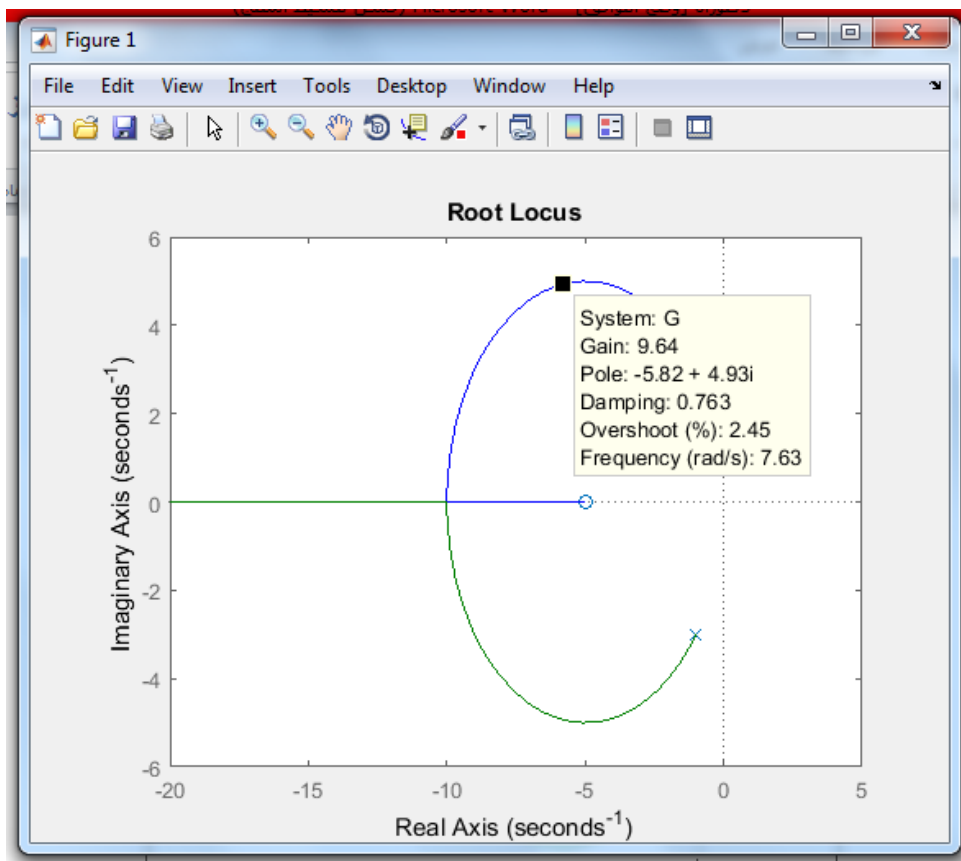

Figure 5-3 Root locus

Example 5-3

Plot the root locus for unity feedback closed loop system whose open loop transfer function is

$$G(s) = \frac{K}{s(s+4)(s^2+2s+2)} \quad (5-6)$$

Solution

Step (1) : find the poles and zeros

$$s(s+4)(s^2+2s+2) = 0 \rightarrow s = 0, -4, (-1+i)(-1-i)$$

Zeros = 0

Step (2) : asymptotes $\frac{\sum \text{poles} - \sum \text{zeros}}{n-m} = \frac{(0-4-1-1)}{4-0} = \frac{-6}{4} = -1.5$

such n number of poles , m number of zeros

Step (3) : angle of asymptotes $\frac{(2q+1)180}{n-m}$ such $q = 0, 1, 2, 3$

If $q = 0 \rightarrow \frac{180}{4} = 45^\circ$

If $q = 1 \rightarrow \frac{3 \times 180}{4} = 135^\circ$

If $q = 2 \rightarrow \frac{5 \times 180}{4} = 225^\circ$

If $q = 3 \rightarrow \frac{7 \times 180}{4} = 315^\circ$

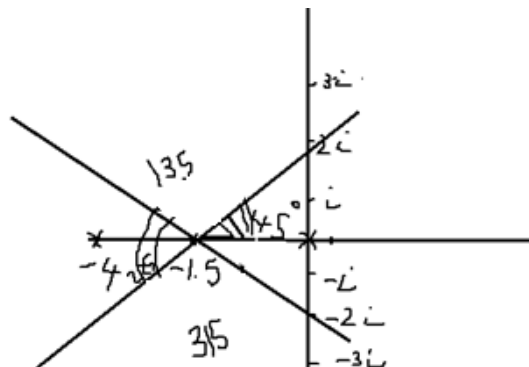

Step (4) : Break away point

Characteristics equations $1 + G(s)H(s) = 0$

$$\therefore 1 + \frac{K}{s(s+4)(s^2+2s+2)} \times 1 = 0$$

Or

$$\frac{(s^2 + 4s)(s^2 + 2s + 2) + K}{(s^2 + 4s)(s^2 + 2s + 2)} = 0$$

$$s^4 + 6s^3 + 10s^2 + 8s + K = 0$$

$$K = -[s^4 + 6s^3 + 10s^2 + 8s]$$

$$\frac{dK}{ds} = -[4s^3 + 18s^2 + 20s]$$

Now we set $\frac{dK}{ds} = 0$

$$-[4s^3 + 18s^2 + 20s] = 0$$

The breakaway point approximated = -3.09

Step (5); To find out imaginary axis erosive we have to form Routh's array

From equation

$$s^4 + 6s^3 + 10s^2 + 8s + K = 0 \quad (5 - 7)$$

s^4	1	10	K	
s^3	6	8	0	
s^2	$\frac{26}{3}$	K	0	
s^1	$\frac{208 - 6K}{\frac{26}{3}}$	0	0	
s^0	K			

$$\frac{208}{3} - 6K = 0, \quad \frac{208}{3} = 6K \rightarrow K = \frac{208}{3}$$

Now Auxiliary equation

$$\frac{26}{3}s^2 + K = 0 \rightarrow s^2 = \frac{-3K}{26} = \frac{-3 \times 208}{26 \times 18} = \frac{-4}{3}$$

$$s^2 = \frac{-4}{3} \quad \therefore S = \mp i \frac{2}{\sqrt{3}} = \mp 1.15 i$$

Step (6) : Angle of departure

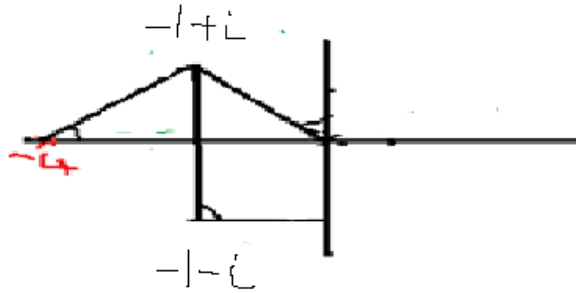

Root locus Design Specifications and the Effect of Gain Variation

The objective of control system design is to construct a system that has a desirable response to standard inputs. A desirable transient response is one that is sufficiently fast without excessive oscillations. A desirable steady-state response is one that follows the desired output with sufficient accuracy. In terms of the response to a unit step input, the transient response is characterized by the following criteria:

1. Time constant t . Time required to reach about 63% of the final value.
2. Rise time T_r . Time to go from 10% to 90% of the final value.
3. Percentage overshoot (PO)

$$PO = \frac{\text{Peak value} - \text{final value}}{\text{final value}} \times 100 \quad (5 - 8)$$

4. Peak time T_p . Time to first peak of an oscillatory response.
5. Settling time T_p . Time after which the oscillatory response remains within a specified percentage (usually 2 percent) of the final value. Clearly, the percentage overshoot and the peak time are intended for use with an oscillatory response (i.e., for a system with at least one pair of complex conjugate poles). For a single complex conjugate pair, these criteria can be expressed in terms of the pole locations.

Consider the second-order system

$$L(s) = \frac{\omega_n^2}{s^2 + 2\zeta\omega_n s + \omega_n^2} \quad (5 - 9)$$

Where ζ is the damping ratio and ω_n is the undamped natural frequency. Then criteria 3 through 5 are given by

$$PO = e^{\pi\zeta} / \sqrt{1 - \zeta^2} \times 100$$

$$T_P = \frac{\pi}{\omega_d} = \frac{\pi}{\omega_n \sqrt{1 - \zeta^2}}$$

$$T_s = \frac{4}{\zeta\omega_n}$$

The damping ratio ζ is an indicator of the oscillatory nature of the response, with excessive oscillations occurring at low ζ values. Hence, ζ is used as a measure of the relative stability of the system. Hence ω_n , is used as a measure of speed of response. For higher-order systems, these measures can provide approximate answers if the time response is dominated by a single pair of complex conjugate poles. This occurs if additional poles and zeros are far in the left half plane or almost cancel. For systems with zeros, the percentage overshoot is higher than predicted, unless the zero is located far in the LHP or almost cancels with a pole. However, are always used in design because of their simplicity. Thus, the design process reduces to the selection of pole locations and the corresponding behavior in the time domain. The root locus summarizes information on the time response of a closed-loop system as dictated by the pole locations in a single plot.

5.4 Root Locus Design

Laplace transformation of a time function yields a function of the complex variable s that contains information about the transformed time function. We can therefore use the poles of the s -domain function to characterize the behavior of the time function without inverse transformation. Shows pole locations in the s -domain and the associated time functions. Real poles are associated with an exponential time response that decays for LHP poles and increases for RHP poles. The magnitude of the pole determines the rate of exponential change.

A pole at the origin is associated with a unit step. Complex conjugate poles are associated with an oscillatory response that decays exponentially for LHP poles and increases exponentially for RHP poles. The real part of the pole determines the rate of exponential change, and the imaginary part determines the frequency

of oscillations. Imaginary axis poles are associated with sustained oscillations. The objective of control system design in the s -domain is to indirectly select a desirable time response for the system through the selection of closed-loop pole locations. The simplest means of shifting the system poles is through the use of an amplifier or proportional controller. If this fails, then the pole locations can be more drastically altered by adding a dynamic controller with its own open-loop poles and zeros. Adding a zero to the system allows the improvement of its time response because it pulls the root locus into the LHP. Adding a pole at the origin increases the type number of the system and reduces its steady-state error but may adversely affect the transient response. If an improvement of both transient and steady-state performance is required, then it may be necessary to add two zeros as well as a pole at the origin. At times, more complex controllers may be needed to achieve the desired design objectives. The controller could be added in the forward path, in the feedback path, or in an inner loop. A prefilter could also be added before the control loop to allow more freedom in design. Several controllers could be used simultaneously, if necessary, to meet all the design specifications. Examples of this control configuration. In this section, we review the design of analog controllers. We restrict the discussion to proportional (P), proportional-derivative (PD), proportional-integral (PI), and proportional-integral-derivative (PID) control.

Proportional Control

Gain adjustment or proportional control allows the selection of closed-loop pole locations from among the poles given by the root locus plot of the system loop gain. For lower-order systems, it is possible to design proportional control systems analytically, but a sketch of the root locus is still helpful in the design process, as seen from the following example.

Example 5-4

A position control system with load angular position as output and motor armature voltage as input consists of an armature controlled DC motor driven by a power amplifier together with a gear train. The overall transfer function of the system is

$$G(s) = \frac{K}{s(s + p)} \quad (5 - 10)$$

Design a proportional controller for the system to obtain

1. A specified damping ratio ζ
2. A specified undamped natural frequency ω_n

Solution

The root locus remains in the LHP for all positive gain values. The closed-loop characteristic equation of the system is given by

$$s(s + p) + K = s^2 + 2\zeta\omega_n s + \omega_n^2 = 0 \quad (5 - 11)$$

Equating coefficients gives

$$P = 2\zeta\omega_n, \quad K = \omega_n^2$$

Which can be solved to yield

$$\omega_n = \sqrt{K}, \quad \zeta = \frac{P}{2\sqrt{K}},$$

Clearly with one free parameter either ζ or ω_n can be selected, but not both. We now select a gain value that satisfies the design specifications.

1. If ζ is given and p is known, then the gain of the system and its undamped natural frequency are obtained from the equations

$$K = \left(\frac{p}{2\zeta}\right)^2, \quad \omega_n = \frac{P}{2\zeta}$$

2. If ω_n is given and p is known, then the gain of the system and its damping ratio are obtained from the equations

$$K = \omega_n^2, \quad \zeta = \frac{P}{2\omega_n}$$

PD Control

As seen from Example above, adding a zero to the loop gain improves the time response in the system. Adding a zero is accomplished using a cascade or feedback controller of the form

$$C(s) = K_p + K_d s = K_d(s + a) \quad (5 - 12)$$

$$a = K_p/K_d$$

This is known as a proportional-derivative, or PD, controller. The derivative term is only approximately realizable and is also undesirable because differentiating noisy input results in large errors. However, if the derivative of the output is measured, an equivalent controller is obtained without differentiation. Thus, PD compensation is often feasible in practice. The design of PD controllers depends on the specifications given for the closed loop system and on whether a feedback or cascade controller is used. For a cascade controller, the system block diagram was shown in Figure (a) and the closed-loop transfer function is of the form

$$G_{cl}(s) = \frac{G(s)C(s)}{1 + G(s)C(s)} \quad (5 - 13)$$

$$= \frac{K_d(s + a)N(s)}{D(s) + K_d(s + a)N(s)}$$

Where $N(s)$ and $D(s)$ are the numerator and denominator of the open-loop gain, respectively. Pole-zero cancellation occurs if the loop gain has a pole at $(-a)$. In the absence of pole-zero cancellation, the closed-loop system has a zero at $(-a)$., which may drastically alter the time response of the system. In figure above shows feedback compensation including a preamplifier in cascade with the feedback loop and an amplifier in the forward path. We show that both amplifiers are often needed. The closed-loop transfer function is

$$= \frac{K_p K_a G(s)}{1 + K_a G(s)C(s)}$$
$$= \frac{K_d K_a N(s)}{D(s) + K_a K_d (s + a)N(s)}$$

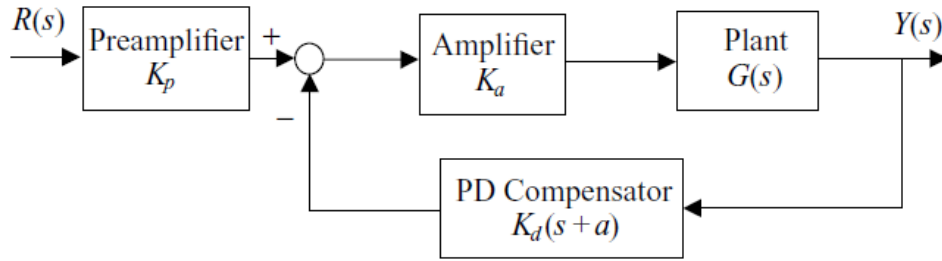

Figure 5-4 Block diagram of a PD feedback compensated system

Example 5-5

Design a PD controller for the type 1 system described

$$G(s) = \frac{K}{s(s + p)} \quad (5 - 14)$$

to meet the following specifications:

1. Specified ζ and ω_n
2. Specified ζ and steady-state error $e(\infty)\%$ due to a ramp input

Consider both cascade and feedback compensation, and compare them using a numerical example.

Solution

The root locus of the PD-compensated system is of the form of figure above. This shows that the system gain can be increased with no fear of instability. With a PD controller the closed-loop characteristic equation is of the form

$$s^2 + ps + K(s + a) = s^2 + (p + k)s + Ka = 0 \quad (5 - 15)$$

$$s^2 + 2\zeta\omega_n s + \omega_n^2 = 0$$

Where $K = K_d$ and $K = K_a K_d$ for feedback compensation

Equating coefficients gives the equations

$$Ka = \omega_n^2, \quad P + K = 2\zeta\omega_n$$

1. In this case, there is no difference between $(K a)$ in cascade and in feedback compensation. But the feedback case requires a preamplifier with the correct gain to yield zero steady-state error due to unit step. We examine the steady-state error in part 2. In either case, solving for K and a gives

$$K = 2\zeta\omega_n - Pa = \frac{\omega_n^2}{2\zeta\omega_n - P}$$

2. For cascade compensation, the velocity error constant of the system is

$$K_v = \frac{Ka}{p} = \frac{100}{e(\infty)\%} \quad (5 - 16)$$

The undamped natural frequency is fixed at

$$\omega_n = \sqrt{Ka} = \sqrt{PK_v}$$

Solving for K and a gives

$$K = 2\zeta\sqrt{PK_v} - P$$

$$a = \frac{PK_v}{2\sqrt{PK_v} - P}$$

For feedback compensation with preamplifier gain K_p and cascade amplifier gain K_a , the error is given by

$$R(s) - Y(s) = R(s) \left[1 - \frac{K_p K_a}{s^2 + (p + K)s + Ka} \right] \quad (5 - 17)$$

$$= R(s) \frac{s^2 + (p + k)a + Ka - K_p K_a}{s^2 + (p + K)s + Ka}$$

Using the final value theorem gives the steady-state error due to a unit ramp input as

$$e(\infty)\% = \lim_{s \rightarrow 0} \frac{1}{s^2} \frac{s^2 + (p + k)a + Ka - K_p K_a}{s^2 + (p + K)s + Ka} \times 100 \quad (5 - 18)$$

This error is infinite unless the amplifier gain is selected such that $K_p K_a = K_a$.

The steady state error is then given by

$$e(\infty)\% = \frac{p + K}{Ka} \times 100$$

The steady-state error $e(\infty)$ is simply the percentage error divided by 100.

Hence, using the equations governing the closed-loop characteristic equation

$$Ka = \frac{p + K}{e(\infty)} = \frac{2\zeta\omega_n}{e(\infty)} = \omega_n^2$$

The undamped natural frequency is fixed at

$$\omega_n = \frac{2\zeta}{e(\infty)}$$

Then solving for K and a we obtain

$$K = \frac{4\zeta}{e(\infty)} - P$$

$$a = \frac{4\zeta^2}{e(\infty)(4\zeta^2 - pe(\infty))}$$

Note that, unlike cascade compensation, ω_n can be freely selected if the steady-state error is specified and ζ is free. To further compare cascade and feedback compensation, we consider the system with the pole $p = 4$, and require $\zeta = 0.7$ and $\omega_n = 10$ rad/s for part

1. These values give $K = K_d = 10$ and $a = 10$. In cascade compensation, gives the closed-loop transfer function

$$G_{cl} = \frac{10(s + 10)}{s^2 + 14s + 100} \quad (5 - 19)$$

For feedback compensation, amplifier gains are selected such that the numerator is equal to 100 for unity steady-state output due to unit step input. For example, one may select

$$K_p = 10 \quad K_a = 10$$

$$K_d = 1 \quad a = 10$$

Substituting in above gives the closed-loop transfer function

$$G_{cl} = \frac{100}{s^2 + 14s + 100} \quad (5 - 20)$$

Therefore, its effect is significant, and the PO increases to over 10% with a faster response. For part 2 with $p = 4$, we specify $\zeta = 0.7$, and a steady-state error of 4%. Cascade compensation requires $K = 10, a = 10$. These are identical to the values of part (i) and correspond to an undamped natural frequency $\omega_n = 10$ rad/s. For feedback compensation we obtain $K = 45, a = 27.222$, gives the closed-loop transfer function

$$G_{cl} = \frac{1225}{s^2 + 49s + 1225} \quad (5 - 21)$$

With $\omega_n = 35$ rad/s.

The PO for the feedback-compensated case is still 4.6%. For cascade compensation, the PO is higher due to the presence of the zero that is close to the complex conjugate poles. Having demonstrated the differences between cascade and feedback compensation. The angle contribution required from the controller for a desired closed-loop pole location s_{cl} is

$$\begin{aligned} \theta_c &= \pm 180 - l(s_{cl}) \\ \theta_c &= \pm 180^\circ - \angle L(s_{cl}) \end{aligned}$$

Where $L(s)$ is the open-loop gain with numerator $N(s)$ and denominator $D(s)$. For a PD controller, the controller angle is simply the angle of the zero at the desired pole location. Applying the angle condition at the desired closed-loop location, it can be shown that the zero location is given by

$$a = \frac{\omega_d}{\tan \theta_c} + \zeta \omega_n$$

Example 5-6

Using a CAD package, design a PD controller for the type 1 position control system of example with transfer function

$$G(s) = \frac{1}{s(s + 4)} \quad (5 - 22)$$

to meet the following specifications:

1. $\zeta = 0.7$ and $\omega_n = 10$ rad/s. $\zeta = 0.7$ and 4% steady-state error due to a unit ramp input
2. The specified steady-state error gives

$$K_v = \frac{100}{e(\infty)\%} = \frac{100}{4\%} = 25 = \frac{Ka}{4} \rightarrow Ka = 100 \quad (5 - 23)$$

The closed-loop characteristic equation of the PD-compensated system is given by

$$1 + K \frac{(s + a)}{s(s + 4)} = 0 \quad (5 - 24)$$

Let K vary with a so that their product K_a remains equal to 100; that the characteristic equation be rewritten as

$$1 + K \frac{s}{s^2 + 4s + 100} = 0$$

The desired location is at the intersection of the root locus with the $\zeta = 0.7$ radial line. The corresponding gain value is $K = 10$, which yields $a = 10$. We obtain the value of K using the MATLAB commands

```
>> g = tf([1, 0], [1, 4, 100]); rlocus(g)
```

The time responses of the two designs are identical and were obtained earlier as the cascade-compensated responses of figure blew, respectively.

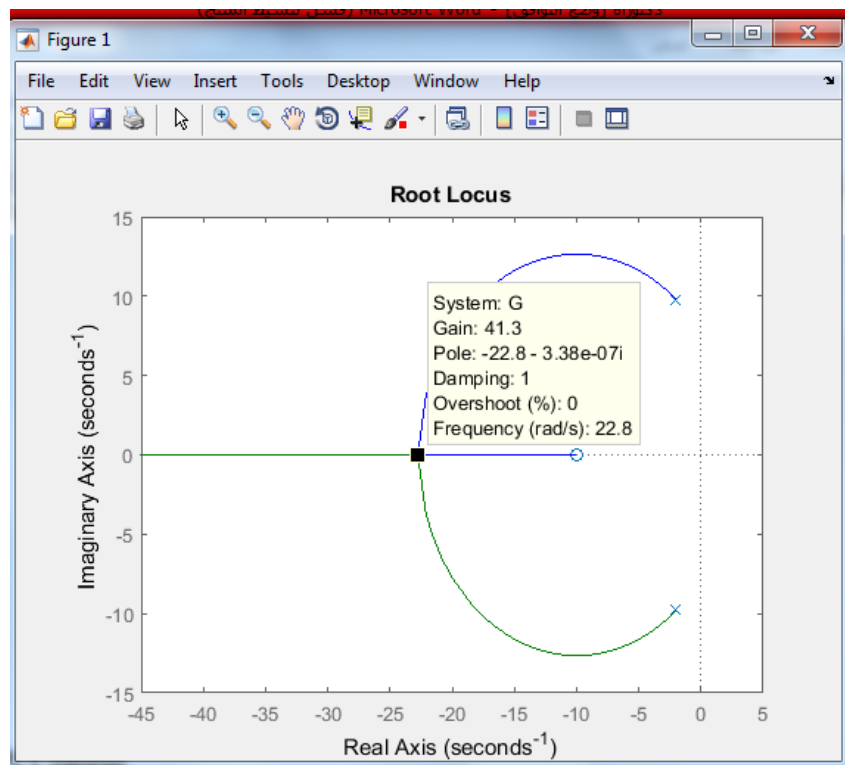
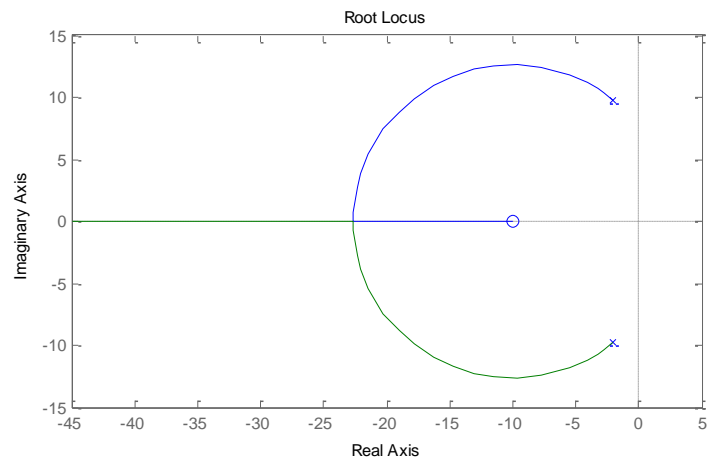

PI Control

Increasing the type number of the system drastically improves its steady-state response. If an integral controller is added to the system, its type number is increased by one but its transient response deteriorates or the system becomes unstable. If a proportional control term is added to the integral control, the controller has a pole and a zero. The transfer function of the proportional-integral (PI) controller is

$$C(s) = K_p + \frac{K_i}{s} = K_p \frac{s + a}{s}, \quad a = \frac{K_i}{K_p} \quad (5 - 25)$$

and is used in cascade compensation. An integral term in the feedback path is equivalent to a differentiator in the forward path and is therefore undesirable. PI design for a plant transfer function $G(s)$ can be viewed as PD design for the plant $G(s)/s$. Thus, can be used for PI design. However, a better design is often possible by placing the controller zero close to the pole at the origin so that the controller pole and zero “almost cancel.” An almost canceling pole-zero pair has a negligible effect on the time response. Thus, the PI controller results in a small deterioration in the transient response with a significant improvement in the steady-state error. The following procedure can be used for PI controller design.

Example 5-7

Plot the root loci for the system shown in Figure 5-5

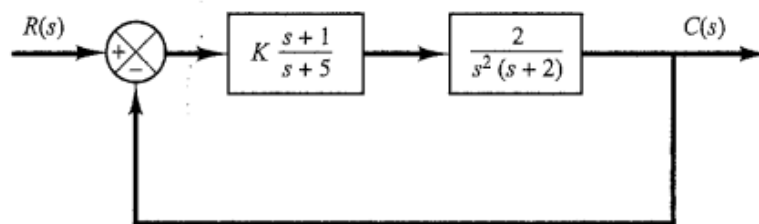
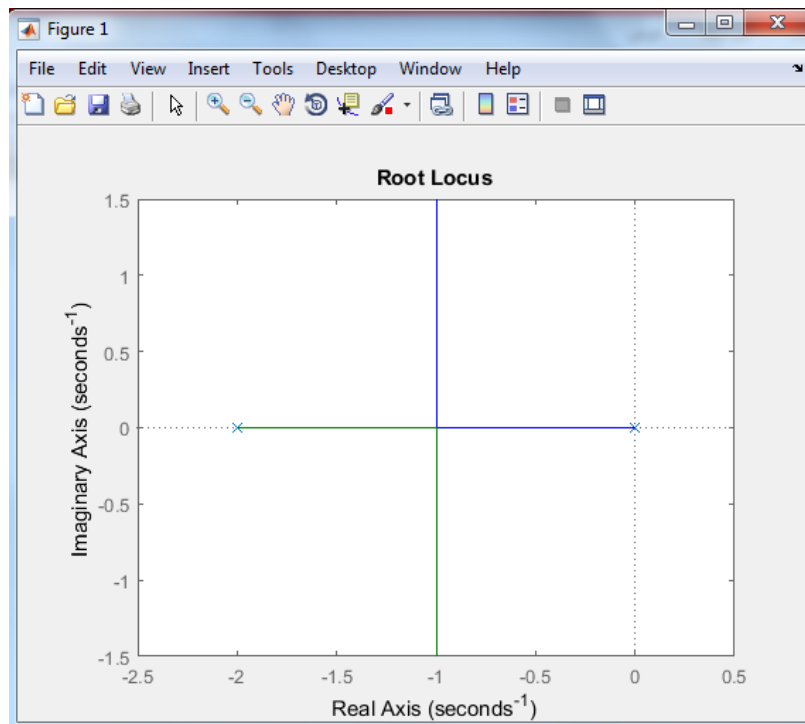

Figure 5-5 control system

```

Editor - C:\Users\yasmien\Documents\MATLAB\Untitled.m
Untitled.m x +
1 - num = [0 0 2]
2 - den = [1 2 0]
3 - rlocus(num,den)

```



Example 5-8

Design a controller for the position control system

$$G(s) = \frac{1}{s(s + 10)} \quad (5 - 26)$$

to perfectly track a ramp input and have a dominant pair with a damping ratio of 0.7 and an undamped natural frequency of 4 rad/s.

Solution

Design 1

Apply Procedure 3.1 to the modified plant

$$G(s) = \frac{1}{s^2(s + 10)}$$

This plant is unstable for all gains as seen from its root locus plot. The design can also be obtained analytically by writing the closed-loop characteristic polynomial as

$$s^3 + 10s^2 + Ks + Ka = (s + \alpha)(s^2 + 2\zeta\omega_n s + \omega_n^2)$$

$$s^3 + (\alpha + 2\zeta\omega_n)s^2 + (2\zeta\omega_n\alpha + \omega_n^2)s + \alpha\omega_n^2$$

Then equating coefficients gives

$$\alpha = 10 - 2\zeta\omega_n = 10 - 2(0.7)(4) = 4.4$$

$$K = \omega_n(2\zeta\alpha + \omega_n) = 4 \times [2(0.7)(4.4) + 4] = 40.64$$

$$\alpha = \frac{\alpha\omega_n^2}{K} = \frac{4.4 \times 4^2}{40.64} = 1.732$$

PID Control

If both the transient and steady-state response of the system must be improved, then neither a PI nor a PD controller may meet the desired specifications. Adding a zero (PD) may improve the transient response but does not increase the type number of the system. Adding a pole at the origin increases the type number but may yield an unsatisfactory time response even if one zero is also added. With a Proportional-integral-derivative (PID) controller, two zeros and a pole at the origin are added. This both increases the type number and allows satisfactory reshaping of the root locus. The transfer function of a PID controller is given by

$$C(s) = K_p + \frac{K_i}{s} + K_d s = K_d \frac{s^2 + 2\zeta\omega_n s + \omega_n^2}{s} \quad (5 - 27)$$

$$2\zeta\omega_n = K_p/K_d \quad \omega_n^2 = \frac{K_i}{K_d}$$

Where K_p , K_i , and K_d are the proportional, integral, and derivative gain, respectively. The zeros of the controller can be real or complex conjugate, allowing the cancellation of real or complex conjugate LHP poles if necessary. In some cases, good design can be obtained by canceling the pole closest to the imaginary axis.

Example 5-9

Design a PID controller for an armature-controlled DC motor with transfer function

$$G(s) = \frac{1}{s(s+1)(s+10)} \quad (5-28)$$

To obtain zero steady-state error due to ramp, a damping ratio of 0.7, and an undamped natural frequency of 4 rad/s.

Solution

Canceling the pole at -1 with a zero and adding an integrator yields the transfer function

$$G(s) = \frac{1}{s^2(s+10)}$$

This is identical to the transfer function. Hence, the overall PID controller is given by

$$C(s) = 50 \frac{(s+1)(s+0.5)}{s}$$

This design is henceforth referred to as Design 1.

A second design is obtained by first selecting a PD controller to meet the transient response specifications. We seek an undamped natural frequency of 5 rad/s in anticipation of the effect of adding PI control.

The gain is reduced to 40, and the controller transfer function for Design 2 is

$$C(s) = 40 \frac{(s+0.349)(s+2.326)}{s}$$

Example 5-10

Design a PID controller to obtain zero steady-state error due to step, a damping ratio of 0.7, and an undamped natural frequency of at least 4 rad/s for the transfer function

$$G(s) = \frac{1}{(s+10)(s^2+2s+10)} \quad (5-29)$$

Solution

The system has a pair of complex conjugate poles, the transfer function

$$G(s) = \frac{1}{s(s + 10)}$$

The root locus of the system, and we can increase the gain without fear of instability. The closed-loop characteristic equation of the compensated system with gain K is

$$s^2 + 10s + K = 0$$

we observe that for a damping ratio of 0.7 the undamped natural frequency is

$$\omega_n = 10/2\zeta = 5/0.7 = 7.143 \text{ rad/s}$$

This meets the design specifications. The corresponding gain is 51.02, and the PID controller is given by

$$C(s) = 51.02 \frac{s^2 + 2s + 10}{s}$$

In practice, pole-zero cancellation may not occur, but near cancellation is sufficient to obtain a satisfactory time response.

Example 5-11

Consider a third-order plant model given by

$$G(s) = \frac{1}{(s + 1)^3} \quad (5 - 30)$$

If a proportional control strategy is selected, i.e., $T_i \rightarrow \infty$ and $T_d \rightarrow 0$ in the PID control strategy, for different values of K_p , the closed-loop responses of the system can be obtained using the following MATLAB statements

```
>> G = tf(1,[1,3,3,1]);
```

```
For Kp = [0.1:0.1:1], G_c = feedback(Kp * G, 1); step(G_c), hold on; end  
figure; rlocus(G, [0,15])
```

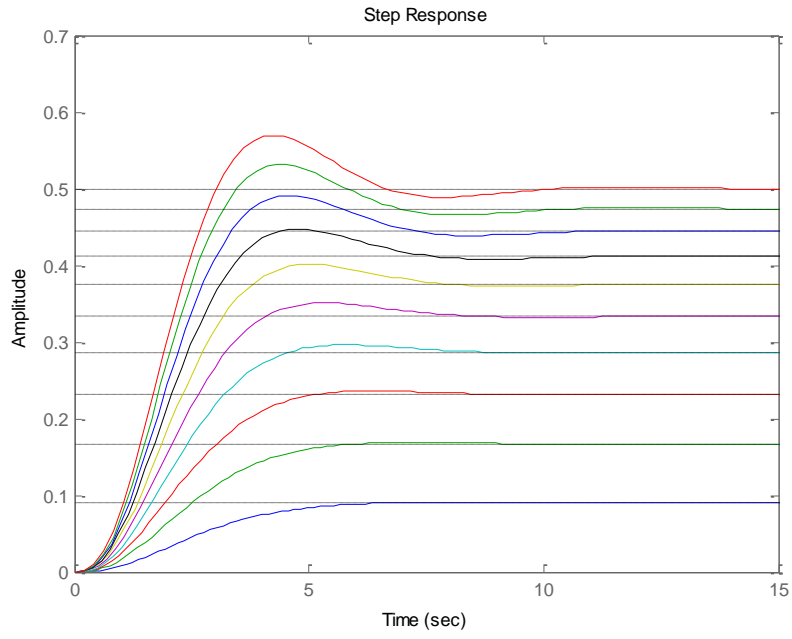

(a) closed-loop step response

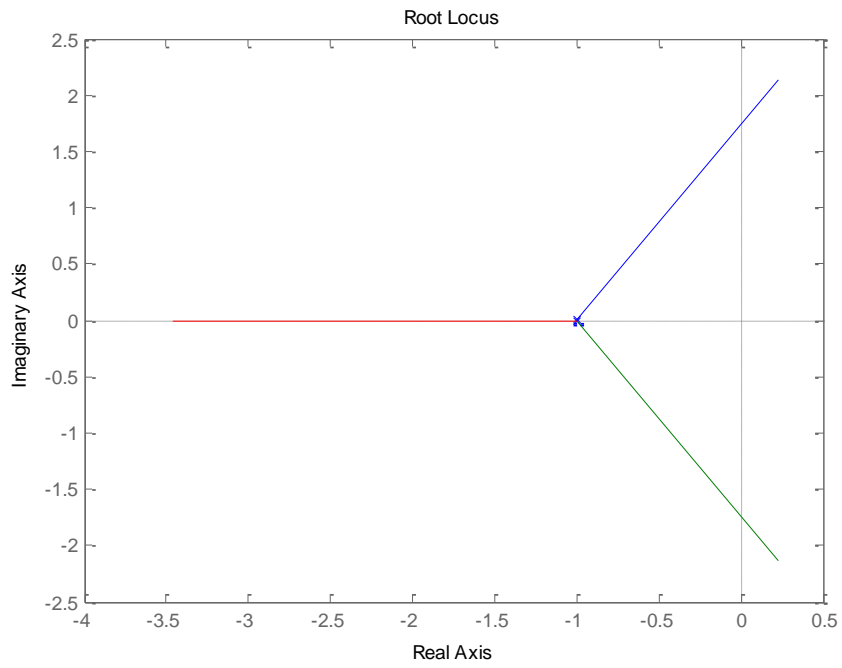

b) Root locus

Chapter 6

Results and Discussion

Model -1

For the system shown determine M_p and T_s when it is excited by unit step input. If for the same system, PD controller having constant $T_d = 1/30$ is used in forward path determine new values of damping ratio, M_p and T_s

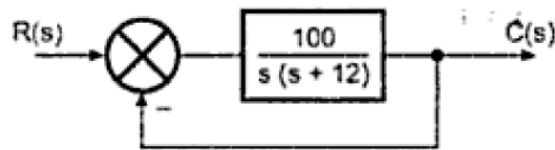

Without controller

$$G(s) = \frac{100}{s(s+12)}, \quad H(s) = 1$$

$$\frac{C(s)}{R(s)} = \frac{100}{s^2 + 12s + 100}$$

$$\omega_n^2 = 100 \quad \therefore \omega_n = 10 \text{ rad/sec}$$

$$2\zeta\omega_n = 12 \quad \therefore \zeta = 0.6$$

$$\omega_d = \omega_n \sqrt{1 - \zeta^2} = 10 \times 0.8 = 8 \text{ rad/sec}$$

$$M_p = e^{-\frac{\pi\zeta}{\sqrt{1-\zeta^2}}} = 9.47 \%$$

$$T_s = \frac{4}{\zeta\omega_n} = 0.666 \text{ sec}$$

With controller

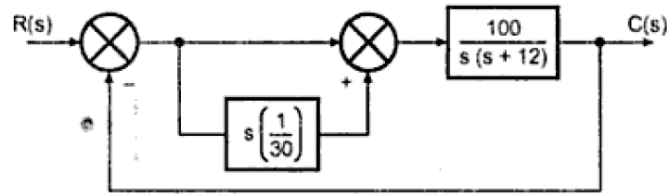

$$G(s) = \frac{\left[1 + \frac{s}{30}\right] 100}{s(s+12)} = \frac{(s+30) \times 3.33}{s(s+12)}, \quad H(s) = 1$$

$$\begin{aligned} \frac{C(s)}{R(s)} &= \frac{\frac{(s+30)3.33}{s(s+12)}}{1 + \frac{(s+30)3.33}{s(s+12)}} = \frac{3.33(s+30)}{s^2 + 12s + 3.33s + 100} \\ &= \frac{3.33(s+30)}{s^2 + 15.33s + 100} \end{aligned}$$

$$\omega_n^2 = 100 \quad \therefore \omega_n = 10 \text{ rad/sec}$$

$$2\zeta\omega_n = 15.33 \quad \therefore \zeta = \frac{15.33}{2 \times 10} = 0.7665$$

$$\therefore \zeta \text{ is improve, } \omega_d = \omega_n \sqrt{1 - \zeta^2} = 10 \sqrt{1 - (0.7665)^2} = 6.4224 \text{ rad/sec}$$

$$M_p = e^{-\frac{\pi\zeta}{\sqrt{1-\zeta^2}}} \times 100 = 2.353 \%$$

$$T_s = \frac{4}{\zeta\omega_n} = 0.5218 \text{ sec}$$

In this model we find different in behavior of the system with controller and without controller. In controller the damping ratio is improve and overshoot decreased to 2.3 from 9.47.

Model -2

The open loop transfer function of a control system is given by

$$G(s) = \frac{1}{s(s+1)(s+4)}$$

Obtain the gain of proportional controller such that the damping ratio will be equal to 0.6?

First we find the poles & zeros, Poles 0, -1, -4 & zeros 0

Then asymptote

$$\frac{\sum \text{poles} - \sum \text{zeros}}{n - m} = \frac{(0 - 1 - 4) - (0)}{3 - 0} = \frac{-5}{3} = -1.66$$

Angle of asymptote

$$\sigma_a = \frac{(2q + 1)\pi}{n - m}$$

Such that n = number of poles , m = number of zeros

$$q = |n - m| - 1 = |3 - 0| - 1 = 2$$

$$q = 0, 1, 2$$

If $q = 0 \rightarrow 60^\circ$, $q = 1 \rightarrow 180^\circ$ If $q = 2 \rightarrow -60^\circ$

Break away point at -0.46 , damping ratio is 0.6

$$\cos\theta = 0.6 \rightarrow \theta = 53.13^\circ$$

$$K = \frac{0.7 * 0.8 * 3.65}{1} = 2.04$$

The proportional controller is adding gain to the system its leads to improve the time response and reduces the error.

Model -3

Suppose the error show in fig below is applied to a PD controller

with $K_p = 3$ and $K_d = 0.2$ sec with $p(0) = 25\%$.

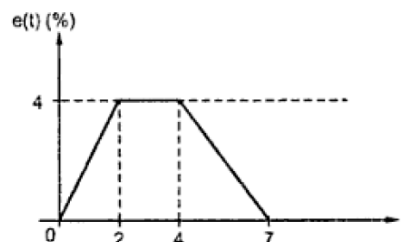

The output PD controller is

$$P(t) = K_p e(t) + K_p K_D \frac{de(t)}{dt} + P(0)$$

It is necessary to obtain output response

$$0 \leq t \leq 2$$

$$e(t) = 2t \quad \text{slop} = 2$$

$$d e(t)/dt = 2$$

$$\therefore P_1(t) = 3 \times 2t + 3 \times 0.2 \times 2 + 25 = 6t + 26.2$$

Thus there is an instantaneous change of $26.2 - 25 = 1.2\%$ produced by this error in the output at $t = 0$

Model-4

An integral controller is used for temperature control within a range $40 - 60^\circ\text{C}$. The set point is 48°C . The controller output is initially 12% when error is zero. The integral constant $K_I = -0.2\%$ controller output per second per percentage error. If the temperature increases to 54°C , calculate the controller output after 2 sec for a constant error.

For integral controller

$$P(t) = K_I \int E_p dt + P(0), \quad E_p = \text{error}$$

$$P(0) = 12\% \quad K_I = -0.2\%$$

$$E_p = \text{constant} = \frac{r - b}{b_{max} - b_{min}} \times 100$$

Now $r = \text{set point} = 48^\circ\text{C}$, $b = \text{Actual temperature} = 54^\circ\text{C}$

$$b_{max} = 60^\circ\text{C}, \quad b_{min} = 40^\circ\text{C}$$

$$E_p = \frac{48 - 54}{60 - 40} \times 100 = -30\%$$

$$\int E_p dt = E_p t \quad \text{as error is constant}$$

$$\therefore P(t) = (-0.2)(-30)(t) + 12$$

$$\text{At } t = 2, \quad P(t) = (0.2 \times 30 \times 2) + 12 = 24 \%$$

The controller change output corresponds to proportional plus integral of the error signal, in this model we use PI controller to eliminate the error.

Model -5

Consider the control system shown in figure below: Draw root locus

(a)- determine the location of dominant poles to have critically damping response then find the time constant the value of K (b) $G_c(s)$ is PD controller, design for specification, damping ratio 0.707 and time constant 0.5 sec.

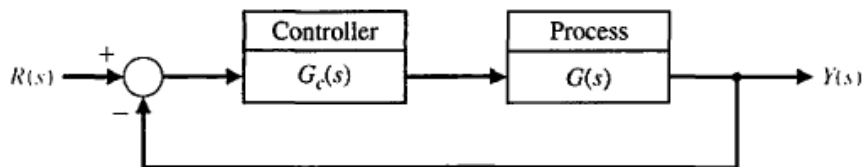

Control system

First we find the poles & zeros, Poles 0, -2, -5 & zeros 0

Asymptote

$$\frac{\sum \text{poles} - \sum \text{zeros}}{n - m} = \frac{(0 - 2 - 5) - (0)}{3 - 0} = \frac{-7}{3} = -2.33$$

Angle of asymptote

$$\sigma_a = \frac{(2q + 1)\pi}{n - m}$$

Such that n = number of poles, m = number of zeros

$$q = |n - m| - 1 = |3 - 0| - 1 = 2$$

$$q = 0, 1, 2$$

If $q = 0 \rightarrow 60^\circ$, $q = 1 \rightarrow 180^\circ$ If $q = 2 \rightarrow -60^\circ$

Break away point at -0.8804

Characteristic equation $s(s + 2)(s + 5) = 0 \rightarrow s^3 + 7s^2 + 10s = 0$

The closed-loop characteristic equation corresponds to the Routh table

$$\begin{array}{r|ll} s^3 & 1 & 10 \\ s^2 & 7 & K \\ s^1 & 70 - K & \\ s^0 & K & \end{array}$$

$$0 < K < 70$$

$$7s^2 + 70 = 0 \rightarrow s = 3.16i$$

The critically damping if $\zeta = 1$, $\theta = \cos^{-1}1 = 0$

$$K = \frac{(0.8804)(1.1296)(4.1196)}{1} = 4.06$$

$$\tau = \frac{1}{0.8804} = 1.136$$

For $\zeta = 0.707$, $\tau = \frac{1}{\zeta\omega_n} = \frac{1}{0.8074} = 1.24$

$$\therefore K = (1.14)(1.44)(4.3) = 7.06$$

The PD controller design

$$\zeta\omega_n = \frac{1}{\tau} = \frac{1}{0.5} = 2$$

$$\theta = \cos^{-1}(0.707) = 45$$

Then

$$\tan 45 = \frac{y}{x} \rightarrow y = x$$

$$\therefore s = x + iy = -2 + 2i$$

To find the angle

$$\theta_{zo} = (135 + 90 + 33.69) - 180$$

$$\therefore \theta_{zo} = 78.69$$

$$\tan 78.69 = \frac{y}{x} \rightarrow x = 0.4$$

$$\therefore z_o = 2.4$$

$$K_D = \frac{(\sqrt{8})(2)(\sqrt{13})}{\sqrt{4.16}} = 10$$

Substituting the value of K_D yield

$$\frac{K_P}{K_D} = z_0 \rightarrow \frac{K_P}{10} = 2.4 \rightarrow K_P = 24$$

$$G_c(s)H(s) = \frac{K_D(s + 2.4)}{s(s + 2)(s + 5)}$$

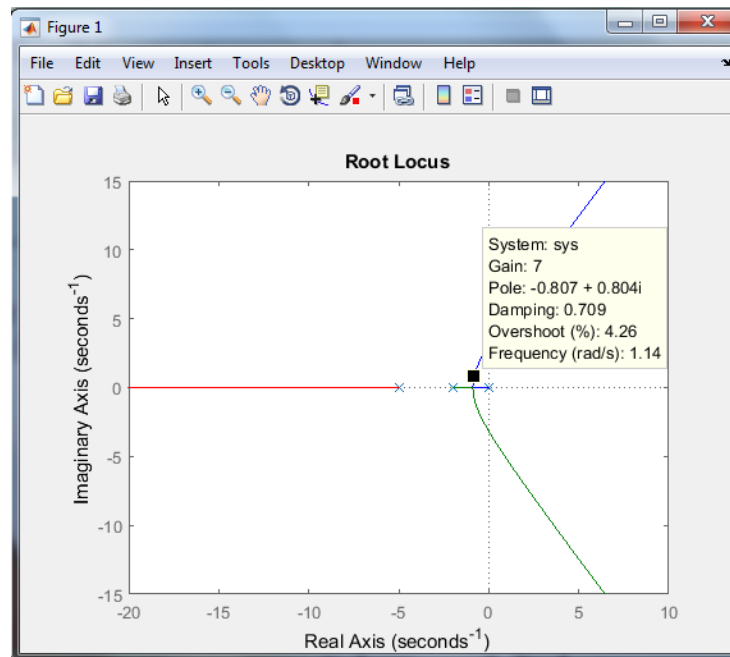

PDcontroller is adding a zero to the system its leading to the desired specification and improve the transeint response.

Model-6

Find the value of paramerter of PID controller using matlab of the system

$$G(s) = \frac{1}{s^2 + 10s + 20}$$

```
>> s= tf('s');  
>> sys =1/(s^2 + 10*s +20);  
>> sys
```

sys =

$$\frac{1}{s^2 + 10 s + 20}$$

Continuous-time transfer function.

```
>> step(sys)
```

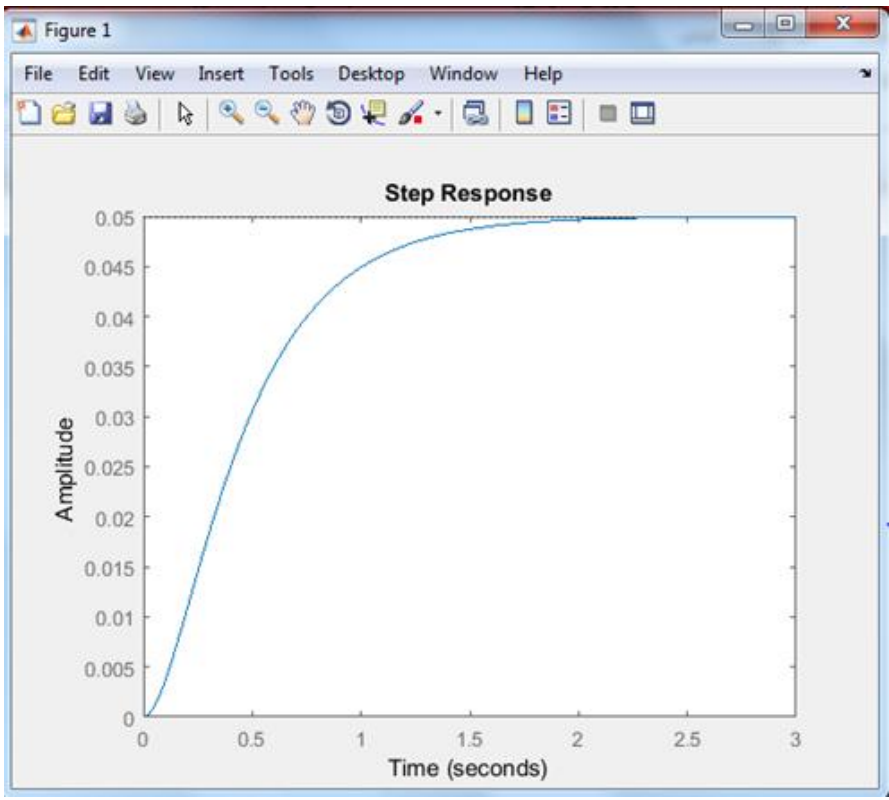

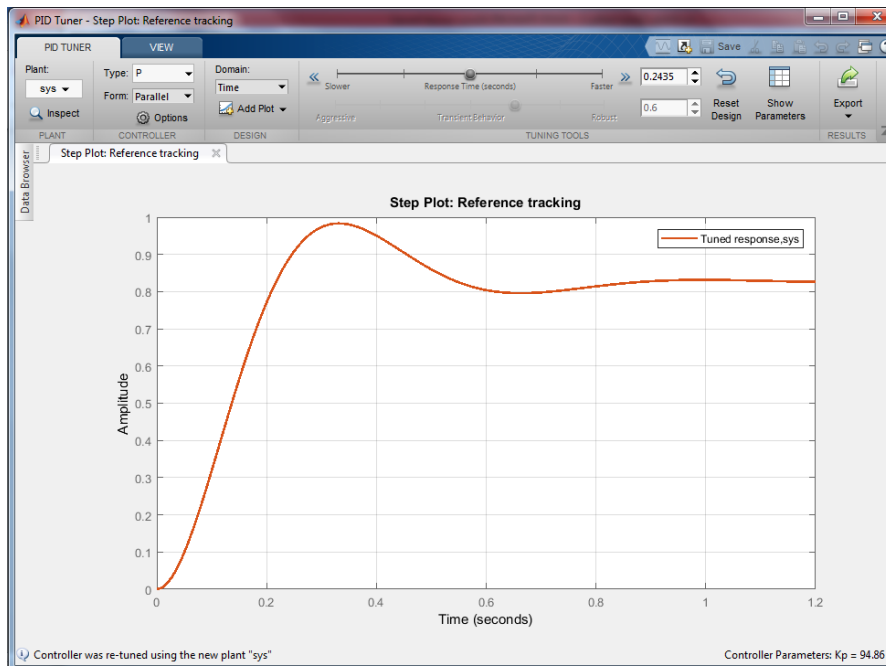
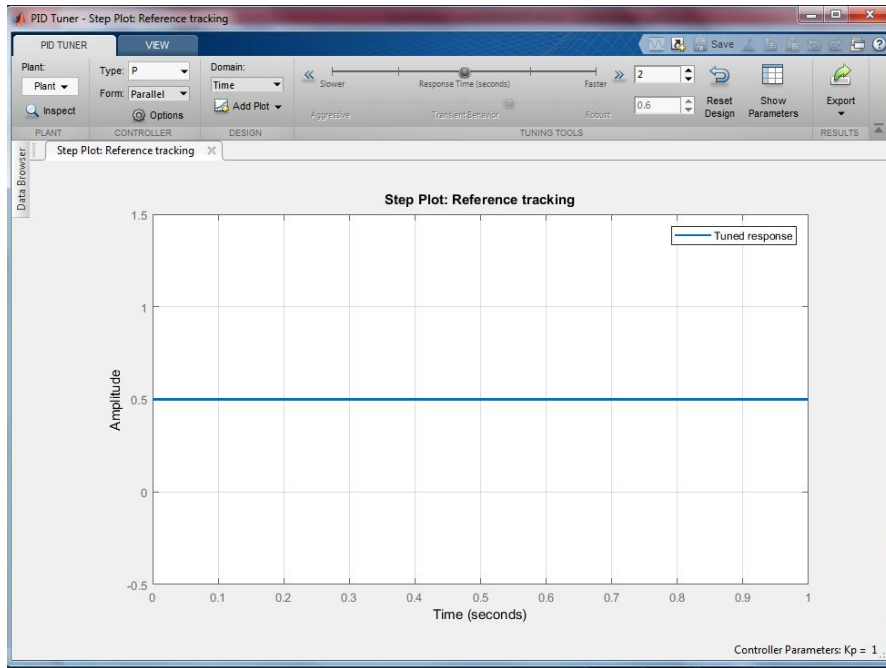

```
>> Kp=152;  
>> Ki=380.5;  
>> Kd=14.2;  
>> cont = Kp+kI/S+Kd*s;
```

```
>> cl_sys = feedback (cont*sys,1);
```

```
>> cl_sys
```

```
cl_sys =
```

```
      14.2 s^2 + 152 s + 380.5  
-----  
s^3 + 24.2 s^2 + 172 s + 380.5
```

Continuous-time transfer function.

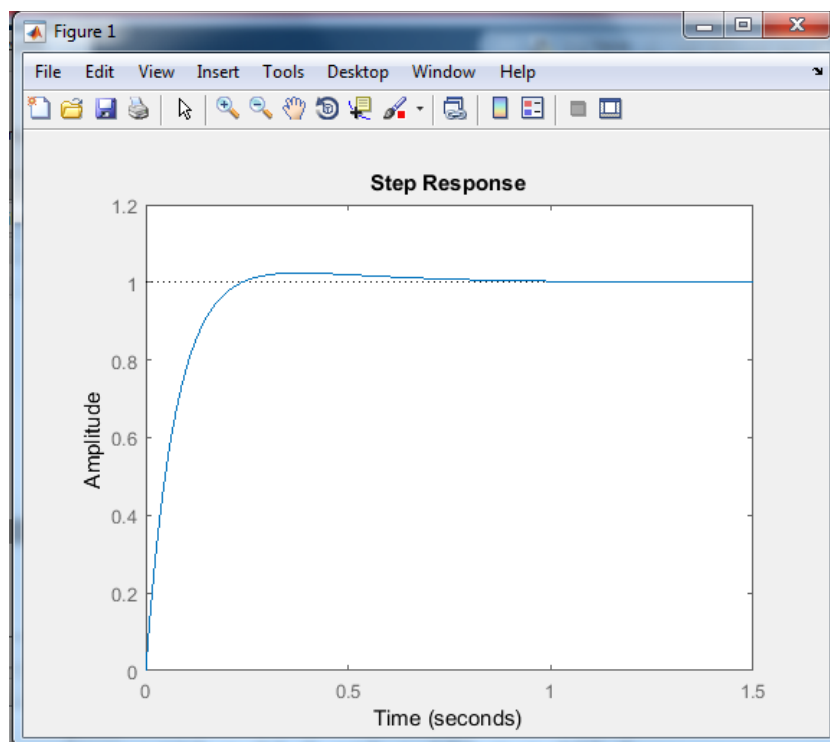

Controller Parameters	
	Tuned
Kp	152.1494
Ki	380.4965
Kd	14.1985
Tf	n/a
Performance and Robustness	
	Tuned
Rise time	0.137 seconds
Settling time	0.492 seconds
Overshoot	2.4 %
Peak	1.02
Gain margin	Inf dB @ NaN rad/s
Phase margin	87 deg @ 14.3 rad/s
Closed-loop stability	Stable

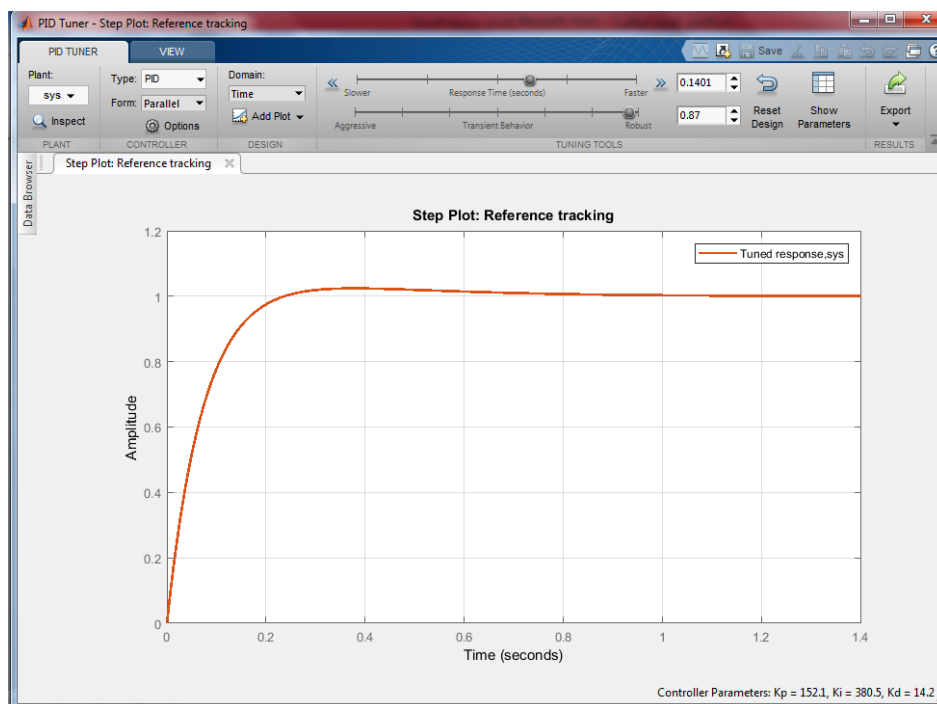

This method is easy and fast to find the parameter of PID controller compare with other method.

Model-7

Consider the system has transfer function

$$G(s) = \frac{20}{s^2 + 10s + 20}$$

Use Simulink?

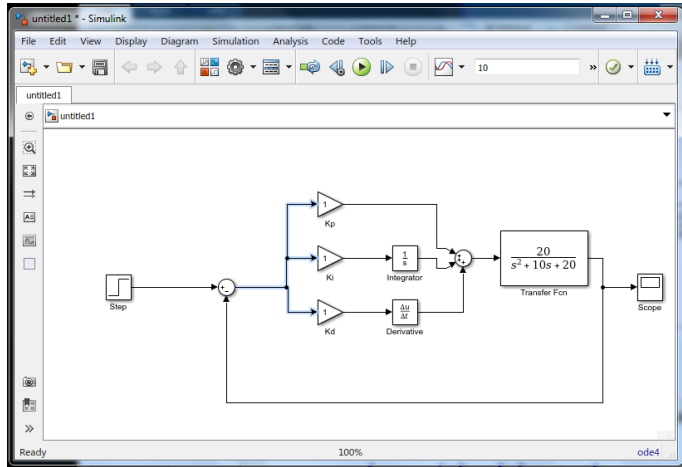
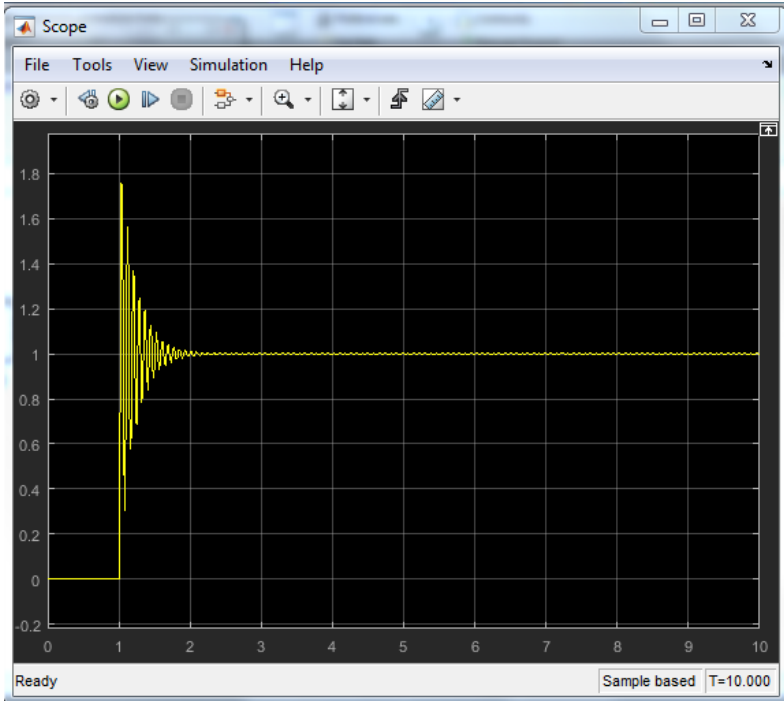
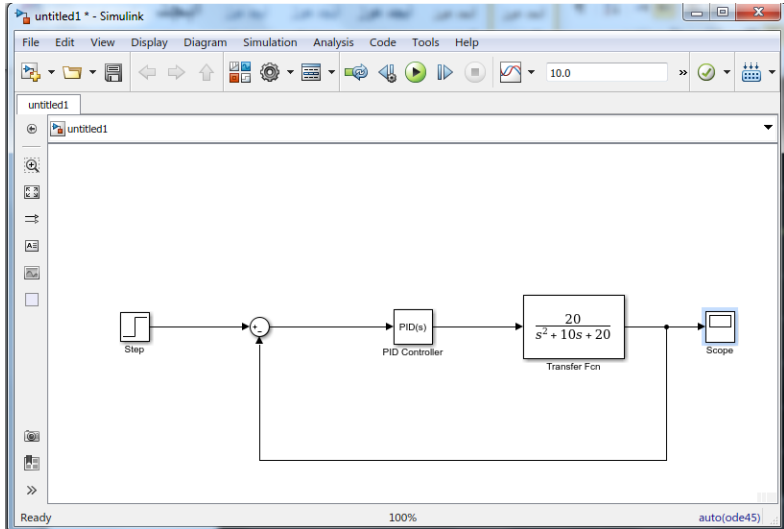

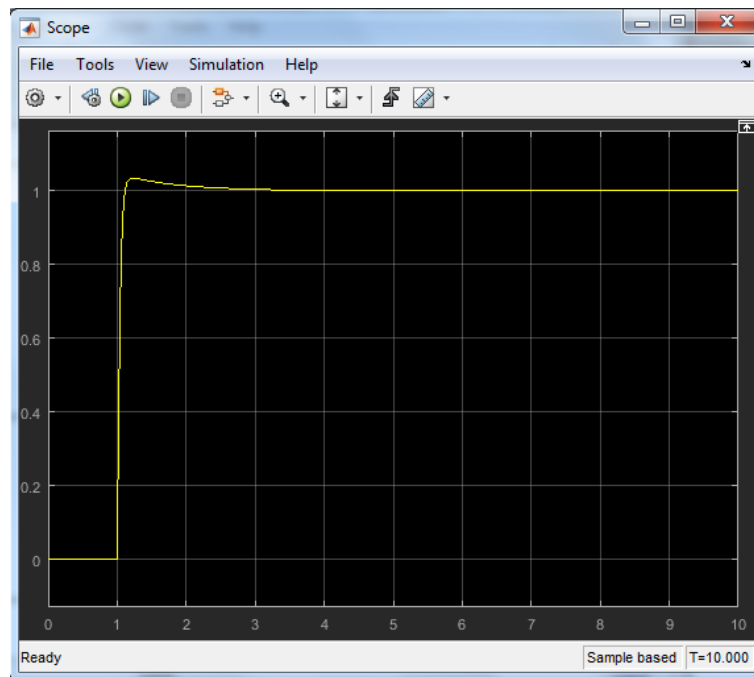
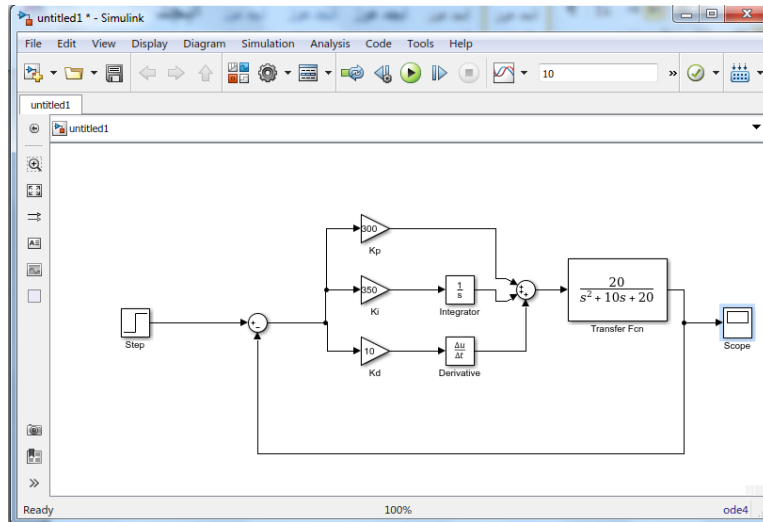

In this model we find that when we add parameter of PID controller (K_P, K_I, K_D) then the system is stable, in case non adding the parameter to the system there is oscillations.

Conclusion

If both the transient and steady-state response of the system must be improved, then neither a PI nor a PD controller may meet the desired specifications. Adding a zero (PD) may improve the transient response but does not increase the type number of the system. Adding a pole at the origin increases the type number but may yield an unsatisfactory time response even if one zero is also added. With a Proportional-integral-derivative (PID) controller, two zeros and a pole at the origin are added. These both increase the type number of the system.

Reference

- [1] Astom, K. J., and T. Hgglund, *Advanced PID Controllers*, ISA Press, 2006.
- [2] D’Azzo, J. J., and C. H. Houpis, *Linear Control System Analysis and Design*, McGraw-Hill, 1988.
- [3] Kuo, B. C., *Automatic Control Systems*, Prentice Hall, 1995.
- [4] Nise, N. S., *Control Systems Engineering*, Benjamin Cummings, 1995.
- [5] O’Dwyer, A., *Handbook of PI and PID Tuning Rules*, Imperial College Press, 2006.
- [6] Ogata, K., *Modern Control Engineering*, Prentice Hall, 1990.
- [7] Van de Vegte, J., *Feedback Control Systems*, Prentice Hall, 1986.
- [8] Visioli, A., *Practical PID Control*, Springer, 2006.
- [9] Mituhiko Araki, Hidefumi Taguchi “Two-Degree-of-Freedom PID controller” *International Journal of control, automation and systems* 2003, pp. 401-411.
- [10] F. G. shinskey, *process control: as taught vs practiced, industrial and engineering chemical research* 41 (16) (2002).
- [11] V.M. Alfao, R. Vilanavo, O. Arrieta, “Simple Robust autotuning of Two-degree-of-freedom(2-DOF) PI controlers”, *ISA transactios* 51(2012), pp. 30-41.
- [12] M. Araki, H. Taguchi, *Two-degree-of-freedom PID controllers- their functions and optimal tuning*, in, *IFAC digital control: past, present and future of PID control* 2000.
- [13] M. Araki, *Two-degree-of-freedom PID control system: part I systems and control* vol. 29 pp. 649-656, 1985.
- [14] K.H. Ang, G. Chong and Y. Li, “PID control system analysis, design and technology,” *IEEE transaction on Control System Technology*, Vol.13, No.4, 2005, pp. 559-576
- [15] K. J. Astrom and Tore H, “PID controller”.
- [16] V.M. Alfao, R. Vilanavo, “Model-reference robust tuning of 2DOF PI controllers for 1st and 2nd order plus dead-time controlled processes”, *Journal of Process control* 22(2012), pp. 359-374.

- [17] F. Haugen, "The Good Gain method for simple experimental tuning of PID controllers", 2012 Norwegian Society of Automatic Control
- [18] Megha jaiswal, Mohan phadnis "speed control of DC motor using genetic algorithm Based PID controller" 2013 IJARCSSE pp. 247-253.
- [19] Michal Kocur, Stefan Kozak, BranislavDvorscak, "Design and Implementation of FPGA - Digital Based PID Controller", IEEE 15th international Carpathian control conference (ICCC), pp. 233-236, 2014.
- [20] Cristina I. Muresan, SilviuFolea, georgeMois, EVA H. Dulf, "Development and implementation of an FPGA based fractional order Controller for a DC motor" Mechatronics 23 (2013), pp. 798-804.
- [21] V.M. Alfao, R. Vilanavo, O. Arrieta, "Robust tuning of Two-degree-of-freedom (2-DOF) PI/PID based cascade control system", Journal of Process Control 19(2009), pp. 1658-1670.
- [22] Sandeep kumar, Temperature control of CSTR using PID and PID (2-DOF) Controller, IJARCSSE may 2012 pp. 326-329.
- [23] Anderson, B. D. O., and J. B. Moore, Linear Optimal Control. Upper Saddle River, NJ: Prentice Hall, 1971.
- [24] Athans, M., and P. L. Falb, Optimal Control: An Introduction to the Theory and Its Applications. New York: McGraw-Hill Book Company, 1965.
- [25] Barnett, S., "Matrices, Polynomials, and Linear Time-Invariant Systems," ZEEE Trans. AutomatCico ntrol, **AC-18** (1973), pp. 1-10.
- [26] Bayliss, L. E., Living Control Systems. London: English Universities Press Limited, 1966.
- [27] Bellman, R., Introductioton Matrix Analysis. New York: McGraw-Hill Book Company, 1960.
- [28] Bode, H. W., Network Analysis and Feedback Design. New York: Van Nostrand Reinhold, 1945.
- [29] Brogan, W. L., Modern Control Theory. Upper Saddle River, NJ: Prentice Hall, 1985.

- [30] Butman, S., and R. Sivan (Sussman), "On Cancellations, Controllability and Observability," *IEEE Trans. Automatic Control*, **AC-9** (1964), pp. 317-8.
- [31] Campbell, D. P., *Process Dynamics*. New York: John Wiley & Sons, Inc., 1958.
- [32] Cannon, R., *Dynamics of Physical Systems*. New York: McGraw-Hill Book Company, 1967.
- [33] Chang, P. M., and S. Jayasuriya, "An Evaluation of Several Controller Synthesis Methodologies Using a Rotating Flexible Beam as a Test Bed," *ASME J. Dynamic Systems, Measurement, and Control*, **117** (1995), pp. 360-73.
- [34] Cheng, D. K., *Analysis of Linear Systems*. Reading, MA: Addison-Wesley Publishing Company, Inc., 1959.
- [35] Churchill, R. V., *Operational Mathematics*, 3rd ed. New York: McGraw-Hill Book Company 1972.
- [36] Coddington, E. A., and N. Levinson, *Theory of Ordinary Differential Equations*. New York: McGraw-Hill Book Company, 1955.
- [37] Craig, J. J., *Introduction to Robotics, Mechanics and Control*. Reading, MA: Addison-Wesley Publishing Company, Inc., 1986.
- [38] Cunningham, W. J., *Introduction to Nonlinear Analysis*. New York: McGraw-Hill Book Company, 1958.
- [39] Dorf, R. C., and R. H. Bishop, *Modern Control Systems*, 9th ed. Upper Saddle River, NJ: Prentice Hall, 2001.
- [40] Enns, M., J. R. Greenwood, J. E. Matheson, and F. T. Thompson, "Practical Aspects of State-Space Methods Part I: System Formulation and Reduction," *IEEE Trans. Military Electronics*, **MIL-8** (1964), pp. 81-93.
- [41] Evans, W. R., "Graphical Analysis of Control Systems," *AIEE Trans. Part II*, **67** (1948), pp. 547-51.
- [42] Evans, W. R., "Control System Synthesis by Root Locus Method," *AIEE Trans. Part II*, **69** (1950), pp. 66-9.
- [43] Evans, W. R., "The Use of Zeros and Poles for Frequency Response or Transient Response," *ASME Trans.* **76** (1954), pp. 135-44.

- [44] Evans, W. R., Control System Dynamics. New York: McGraw-Hill Book Company, 1954.
- [45] Franklin, G. F, J. D. Powell, and A. Emami-Naeini, Feedback Control of Dynamic Systems, 3rd ed. Reading, MA: Addison-Wesley Publishing Company, Inc., 1994.
- [46] Friedland, B., Control System Design. New York: McGraw-Hill Book Company, 1986.
- [47] Fu, K. S., R. C. Gonzalez, and C. S. G. Lee, Robotics: Control, Sensing, Vision, and Intelligence. New York: McGraw-Hill Book Company, 1987.
- [48] Gantmacher, F. R., Theory of Matrices, Vols. I and II. New York: Chelsea Publishing Company, Inc., 1959.
- [49] Gardner, M. F, and J. L. Barnes, Transients in Linear Systems. New York: John Wiley & Sons, Inc., 1942.
- [50] Gibson, J. E., Nonlinear Automatic Control. New York: McGraw-Hill Book Company, 1963.
- [51] Gilbert, E. G., "Controllability and Observability in Multivariable Control Systems," LSIAM Control, ser. A, **1** (1963) , pp. 128-51.
- [52] Graham, D., and R. C. Lathrop, "The Synthesis of Optimum Response: Criteria and Standard Forms," AIEE Trans. Part II, 72 (1953), pp. 273-88.
- [53] Hahn, W., Theory and Application of Liapunov's Direct Method. Upper Saddle River, NJ: Prentice Hall, 1963.
- [54] Halmos, R., Finite Dimensional Vector Spaces. New York: Van Nostrand Reinhold, 1958.
- [55] Higdon, D. T., and R. H. Cannon, Jr., "On the Control of Unstable Multiple-Output Mechanical Systems," ASME Paper no. **63**- WA-148, 1963,
- [56] Irwin, J. D., Basic Engineering Circuit Analysis. New York: Macmillan, Inc., 1984.
- [57] Jayasuriya, S., "Frequency Domain Design for Robust Performance Under Parametric, Unstructured, or Mixed Uncertainties," ASME J. Dynamic Systems, Measurement, and Control, **115** (1993), pp. 439-51.

- [58] Kailath, T., *Linear Systems*. Upper Saddle River, NJ: Prentice Hall, 1980.
- [59] Kalman, R. E., "Contributions to the Theory of Optimal Control," *Bol. Soc Mat. Mex.*, **5** (1960), pp. 102-19.
- [60] Kalman, R. E., "On the General Theory of Control Systems," *Proc First Intern. Cong. IFAC, Moscow, 1960, Automatic and Remote Control*. London: Butterworths & Company Limited, 1961, pp. 481-92.
- [61] Araki, M.: On two-degree-of-freedom PID control system. Tech. rep., SICE research committee on modeling and control design of real systems (1984)
- [62] Araki, M.: Two-degree-of-freedom control system—I. *Syst. Control* **29**, 649–656 (1985)
- [63] Araki, M., Taguchi, H.: Two-degree-of-freedom PID controllers. *Int. J. Control Autom. Syst.* **1**(4), 401–411 (2003)
- [64] Taguchi, H., Araki, M.: Two-degree-of-freedom PID controllers—their functions and optimal tuning. In: *IFAC Digital Control: Past, Present and Future of PID Control*, April 5–7. Terrassa, Spain (2000)
- [65] Taguchi, H., Araki, M.: Survey of researches on two-degree-of-freedom PID controllers. In: *The 4th Asian Control Conference*, Sept 25–27, Singapore (2002)
- [66] Gerry, J.P.: A comparison of PID algorithms. *Control Eng.* **34**(3), 102–105 (1987)
- [67] O'Dwyer, A.: *Handbook of PI and PID Controller Tuning Rules*, 3rd edn. Imperial College Press, London (2009)
- [68] Åström, K.J., Hägglund, T.: *PID Controllers: Theory, Design and Tuning*. Instrument Society of America, Research Triangle Park, NC 27709, USA (1995)
- [69] Seborg, D.E., Edgar, T.F., Mellichamp, D.A.: *Process Dynamics and Control*, 2nd edn. Wiley, Hoboken, NJ 07030, USA (2004)
- [70] Sung, S.W., Lee, I.B.: *Process Identification and PID Control*. John Wiley & Sons (Asia) Pte Ltd, Singapore (2009)
- [71] Tan, W., Yuan, Y., Niu, Y.: Tuning of PID controller for unstable process. In: *IEEE International Conference on Control Applications*. Kohala Coast-Island of Hawai'i, Hawai'i, USA, Aug 22–27 (1999)

- [72] Visioli, A.: Practical PID Control. Springer Verlag London Limited (2006)
- [73] Johnson, M.A.: PID Control—New Identification and Design Methods, chap. PID Control Technology, pp. 1–46. Springer-Verlag London Ltd., U.K. (2005)
- [74] Skogestad, S.: Simple analytic rules for model reduction and PID controller tuning. *J. Process Control* **13**, 291–309 (2003)
- [75] Alfaro, V.M., Vilanova, R.: Conversion formulae and performance capabilities of two-degree-of-freedom PID control algorithms. In: 17th IEEE International Conference on Emerging Technologies and Factory Automation (ETFA 2012) (2012). Sept 17–21, Kraków, Poland
- [76] Hägglund, T.: A unified discussion on signal filter in PID control. *Control Eng. Pract.* **21**, 994–1006 (2013)
- [77] Alfaro, V.M., Vilanova, R.: Performance and robustness considerations for tuning of proportional integral/proportional integral derivative controllers with two input filters. *Ind. Eng. Chem. Res.* **52**, 18287–18302 (2013)
- [78] Anderson, B. D. O. and J. B. Moore. *Linear Optimal Control*, Englewood Cliffs, NJ : Prentice-Hall, 1971 .
- [79] Astrom, K . J. "Robustness of a design based on assignment of poles and zeros," *IEEE Trans . Automatic Control*, Vol . AC-25, pp. 588-591, 1980 .
- [80] Astrom, K . J. and B . Wittenmark. *Computer Controlled Systems : Theory and Design*, Englewood Cliffs, NJ : Prentice-Hall, 1984 .
- [81] *Adaptive Control*, Reading, MA: Addison-Wesley, 1989 .
- [82] Athans, M . and P . L. Falb. *Optimal Control*, New York: McGraw-Hill, 1966.
- [83] Atherton, D. P. *Nonlinear Control Engineering*, London : Van Nostrand Reinhold, 1982.
- [84] Bode, H. W. *Network Analysis and Feedback Amplifier Design*, Princeton, NJ: Van Nostrand, 1945 .

- [85] Boyd, S. P. et al. "A new CAD method and associated architectures for linear controllers," IEEE Trans. Automatic Control, Vol . 33, pp. 268-283, 1988 .
- [86] Callier, F. M. and C . A. Desoer . Multivariable Feedback Systems, New York: Springer-Verlag, 1982.
- [87] Chang, S. S. L. Synthesis of Optimal Control Systems, New York : McGraw- Hill, 1961 .
- [88] Chen, C. T. "Design of feedback control systems," Proc. Natl. Electronic Conf., Vol. 57, pp. 46-51, 1969 .
- [89] Analysis and Synthesis of Linear Control Systems, New York: Holt, Rinehart and Winston, 1975 .
- [90] One-Dimensional Digital Signal Processing, New York: Dekker, 1979.
- [91] "A contribution to the design of linear time-invariant multivariable systems," Proc . Am. Automatic Control Conf., June, 1983.
- [92] Linear System Theory and Design, New York: Holt, Rinehart and Winston, 1984 .
- [93] Control System Design:Conventional, Algebraic and Optimal Methods, Stony Brook, NY : Pond Woods Press, 1987 .
- [94] "Introduction to the Linear Algebraic Method for Control System Design," IEEE Control Systems Magazine, Vol .7, No.5, pp. 36-42, 1987.
- [95] System and Signal Analysis, New York: Holt, Rinehart and Winston, 1989.
- [96] Chen, C. T. and B.Seo."Applications of the Linear Algebraic Method for Control System Design," IEEE Control Systems Magazine,Vol. 10, No. 1, pp. 43-47, 1989 .
- [97] "The Inward Approach in the Design of Control Systems," IEEE Trans . on Education, Vol . 33, pp. 270-278, 1990 .
- [98] Chen, C. T. and S . Y. Zhang. "Various implementations of implementable transfer matrices," IEEE Trans. Automatic Control, Vol . AC-30, pp. 1115-1118, 1985 .

- [99] Coughanowr, D.R. Process Systems Analysis and Control, 2nd ed., New York: McGraw-Hill, 1991.
- [100] Craig, J.J. Introduction to Robotics, 2nd ed., Reading MA: Addison-Wesley, 1989.
- [101] Daryanani, G. Principles of Active Network Synthesis and Design, New York: Wiley, 1976.
- [102] Doebelin, E . O. Control System Principles and Design, New York: John Wiley, 1985 .
- [103] Doyle, J . and G. Stein. "Multivariable feedback design : Concepts for classical/ modern analysis," IEEE Trans. on Automatic Control, Vol . 26, No. 1, pp. 4-16, 1981 .
- [104] Evans, W. R. "Control system synthesis by the root locus method," Trans . AIEE, Vol. 69, pp . 67-69, 1950 .
- [105] Franklin, G . F., J. D. Powell, and M . L. Workman. Digital Control of Dynamic Systems, 2nd ed., Reading, MA: Addison-Wesley, 1990 .
- [106] Franklin, G. F., J.D. Powell, and A. Emami-Naeini. Feedback Control of Dynamic Systems, Reading, MA : Addison-Wesley, 1986.
- [107] Frederick, D . K., C. J. Herget, R . Kool, and C. M. Rimvall. "The extended list of control software," Electronics, Vol. 61, No . 6, p. 77, 1988 .
- [108] Gawthrop, P. J. and P . E. Nomikos . "Automatic tuning of commercial PID controllers for single-loop and multiloop applications," IEEE Control Systems Magazine, Vol. 10, No . 1, pp. 34-42, 1990.
- [109] Gayakwad, R. and L . Sokoloff. Analog and Digital Control Systems, Englewood Cliffs, NJ : Prentice-Hall, 1988 .
- [110] Graham, D. and R.C. Lathrop. "The synthesis of optimum response Criteria and standard forms," AIEE, Vol. 72, Pt. II, pp. 273-288, 1953
- [111] Hang, C. C. "The choice of controller zeros," IEEE Control Systems Magazine, Vol. 9, No . 1, pp . 72-75, 1989 .
- [112] Hang, C.C. and K. K. Sin. "A comparative performance study of PID autotuners," IEEE Control Systems Magazine, Vol . 11, No. 5, pp. 41-47, 1991.

- [113] Horowitz, I . M. Synthesis of Feedback Systems, New York: Academic Press, 1963.
- [114] Jacob, J. M. Industrial Control Electronics: Application and Design, Englewood Cliffs, NJ : Prentice-Hall, 1989 .
- [115] Jury, E. I. Sampled-Data Control Systems, New York : Wiley, 1958.
- [116] Killian, M. J. "Analysis and Synthesis of Phase-locked Loop Motor Speed Control Systems," Master Thesis, State University of New York, 1979.
- [117] Ku, Y. H. Analysis and Control of Linear Systems, Scranton, PA: International Textbook, 1962.
- [118] Kucera, V. Discrete Linear Control-The Polynomial Equation Approach, Chichester, UK: Wiley, 1979 .
- [119] Kuo, B . C. Automatic Control Systems, 3rd ed . Englewood Cliffs, NJ : Prentice-Hall, 1975 .
- [120] Kuo, B. C. Digital Control Systems, New York: Holt, Rinehart and Winston, 1980.
- [121] Lin, J. L., J. J. Sheen, and C. T. Chen . "Comparisons of various implementations of quadratic optimal systems," Technical Report, National Cheng- Kung University, Taiwan, 1986 .
- [122] Luenberger, D . G. "Observing the state of a linear system," IEEE Trans . Military Electronics, Vol. MIL-8, pp . 74-80, 1964 .
- [123] Middleton, R. H. and G.C. Goodwin. Digital Control and Estimation, A Unified Approach, Englewood Cliffs, NJ : Prentice-Hall, 1990 .
- [124] Moler, C . and C. F. Van Loan . "Nineteen dubious ways to compute the exponential of a matrix," SIAM Review, Vol. 20, pp. 801-836, 1978 .
- [125] Newton, G . C. Jr., L. A. Gould, and J . F. Kaiser. Analytical Design of Linear Feedback Controls, New York: Wiley, 1959 .
- [126] Norimatsu, T. and M. Ito. "On the zero non-regular control system," J. Inst. Elec. Eng . Japan, Vol . 81, pp . 566-575, 1961 . See also B.Porter, "Comments on `On undershoot and nonminimum phase zeros'," IEEE Trans . Automatic Control, Vol . AC-32, pp. 271-272, 1987 .

- [127] Northrop, R . B. Analog Electronic Circuits, Analysis and Application, Reading, MA: Addison-Wesley, 1990 .
- [128] Nyquist, H. "Regeneration theory," Bell Syst. Tech . J., Vol. 11, pp. 126-147, 1932.
- [129] Ogata, K. Discrete-Time Control Systems, Englewood Cliffs, NJ : Prentice-Hall, 1987 .
- [130] Rosenbrock, H . H. State-Space and Multivariable Theory, New York: Wiley- Interscience, 1970 .
- [131] Seo, B."Computer-Aided Design of Control Systems" PhD dissertation, SUNY, Stony Brook, NY, 1989 .
- [132] Shipley, D. P. "A unified approach to synthesis of linear systems," IEEE Trans. on Automatic Control, Vol . AC-8, pp. 114-125, April, 1963
- [133] Slotine, J-J . E. and W. Li. Applied Nonlinear Control, Englewood Cliffs, NJ : Prentice-Hall, 1990 .
- [134] Truxal, J. G. Automatic Feedback Control System Synthesis, New York: McGraw-Hill, 1955 .
- [135] Introductory System Engineering, New York: McGraw-Hill, 1972 .
- [136] Tsui, C.C. "An analytical solution to the equation $TA-FT = LC$ and its applications," IEEE Trans. on Automatic Control, Vol . 32, No. 8, pp . 742-744,1987.
- [137]"On preserving the robustness of optimal control system with observers," IEEE Trans.on Automatic Control, Vol. 32, No . 9, pp. 823-826, 1987 .
- [138] Van de Vegte, J . Feedback Control Systems, 2nd ed., Englewood Cliffs, NJ : Prentice-Hall, 1990 .
- [139] Vidyasagar,M."On the well-posedness of large-scale interconnected systems," IEEE Trans . on Automatic Control, Vol . AC-25, pp . 413-421, 1980.
- [140] . Control System Synthesis : A Factorization Approach, Cambridge, MA: MIT Press, 1985 .
- [141] Willems,J. C. The Analysis of Feedback Systems,Cambridge, MA: MIT Press, 1971.

- [142] Wolovich, W. A. *Linear Multivariable Systems*, New York: Springer-Verlag, 1974.
- [143] Wonham, W. M. "On pole assignment in multi-input controllable linear systems," *IEEE Trans. on Automatic Control*, Vol. AC-12, pp. 660-665, 1967.
- [144] *Linear Multivariable Control*, New York: Springer-Verlag, 1985.
- [145] Youla, D.C., J. J. Bongiorno, Jr., and C. N. Lu. "Single-loop feedback stabilization of linear multivariable dynamical plants," *Automatica*, Vol. 10, pp. 159-173, 1974.
- [146] Ziegler, J. G. and N. B. Nichols. "Optimum settings for automatic controllers," *Trans. ASME*, Vol. 64, pp. 759-768, 1942.
- [147] "Process lags in automatic control circuits," *Trans. ASME*, Vol. 65, pp. 433-442, 1943.

