



Sudan University of Science and Technology
College of Graduate Studies



Design of Prosthetic Foot Using Computer Aided Design

تصميم قدم صناعية باستخدام برامج الحاسوب المساعدة في
التصميم

A Thesis submitted in partial fulfilment of the requirement for MSc in
Biomedical engineering

By:

Yousra Yagoub Elmadni Ibrahim

Supervisor:

Dr.Megdi Elnour Abdelrahman

December 2018

"اقرأ باسم ربك الذي خلق، خلق الإنسان من علق، اقرأ وربك الأكرم،
الذي علم بالقلم، علم الإنسان ما لم يعلم".

سورة العلق (1-5)

Dedication

With all love and sincerity, I dedicate this thesis to my family members who encourage and support me through all the levels of my education as well as life.

To all my teachers who taught me and without them I will not be in this success.

To all who helped me in fulfilling this thesis.

To all my dear colleagues and friends.

Acknowledgement

I am very grateful and thankful to ALLAH for giving me the strength and power to accomplish this thesis.

I always appreciate and thank what my father does for me, whenever I feel tired I find him by my side helping and supporting.

I am very thankful to the person who always gave me moral and technical guidance, and he was very patient with me, and generous in giving information my supervisor **Dr.Megdi Alnour** at Sudan University of Science and Technology.

Thanks to National Authority for Prosthetics and Orthotics for supplying with all the information related to this thesis especially ENG. gmal gad.

Abstract

Trans tibial prosthetics in Sudan need to have attention, according to the National Authority for Prosthetics and Orthotics (NAPO) statistics trans tibial amputees represents the biggest number between the other levels of amputation in Sudan. Design of foot and pylon as a single part using SOLIDWORKS 2016 program had been made, and then analysis using FEA method by ANSYS 15.0 program which is powerful Finite Element Analysis Software. Applying ground reaction force during the five stages of stance phase to aluminium alloy, stainless steel, titanium alloy materials had been made and eventually two materials in one design stainless steel and titanium alloy, this means in some parts of the design stainless Steel was used and in others titanium alloy. Using two materials stainless steel and titanium alloy was the best, and it had maximum Equivalent stresses values (77.712MPa, 96.948MPa, 365.1MPa, 494.67MPa, and 750.02MPa) which are less than the yield strength of the material in all stages. The probability of failure of design to withstand the applied loads using safety factor showed that this design is suitable for persons who their mass are below 60 kg and their foot length is 24 cm.

المستخلص

الاطراف الصناعية تحت الركبه فى السودان تحتاج ان تحظى بمزيد من الاهتمام، وفقاً لإحصائيات الهيئة العامه للأجهزة التعويضية للمعاقين يمثل المبتورين تحت الركبه النسبه الاكبر من بين انواع البتر الاخرى. صممت قدم وساق كوحدة واحده باستخدام برنامج سوليدورك، ومن ثم تحليله بواسطة برنامج انسيس الذى يعتبر من اقوى البرامج باستخدام طريقه تحليل العناصر الانهائية. طبقت قوة رد فعل الارض خلال المراحل الخمس من المشى باستخدام مواد سبائك الألومنيوم، الفولاذ المقاوم للصدأ، سبائك التيتانيوم واخيرا اثنين من المواد الفولاذ المقاوم للصدأ وسبائك التيتانيوم فى تصميم واحد، وهذا يعني فى بعض الاجزاء من التصميم تم استخدام الفولاذ المقاوم للصدأ وفى الاجزاء الاخرى سبائك التيتانيوم. تبين ان استخدام المادتين الفولاذ المقاوم للصدأ وسبائك التيتانيوم هو الأفضل، وكان لديه الحد الأقصى من الضغوط المكافئة بقيم (77.712 ميغا باسكال، 96.948 ميغا باسكال، 365.1 ميغا باسكال، 494.67 ميغا باسكال، 750.02 ميغا باسكال) وهى اقل من قوة الخضوع للمادة فى جميع المراحل.احتماليه فشل التصميم فى تحمل الاحمال المسلطه عليه باستخدام عامل الامان اظهر ان التصميم مناسب للاشخاص الذين يقل وزنهم عن 60 كجم وطول اقدمهم 24سم.

Table of Contents

Content	Page No
Dedication.....	III
Acknowledgement.....	IV
Abstract.....	V
المستخلص.....	VI
List of tables.....	XII
List of figures.....	XIV

Chapter One

General Overview

1.1 Introduction.....	1
1.2 Problem Statement.....	2
1.2.1 Solution.....	2
1.3 Objectives.....	2
1.3.1 General objective.....	2
1.3.2 Specific objectives.....	2
1.4 Thesis layout.....	3

Chapter two

Theoretical Background

2.1 Ground reaction force (GRF).....	4
2.2 The Gait.....	4
2.2.1 Gait cycle (stride).....	4
2.2.3 Walking speed.....	5

2.4.4 Stance Phase.....	5
2.2.4.1 Heel strike	6
2.2.4.2 Foot flat	6
2.2.4.3 Midstance	6
2.2.4.4 Heel-off	7
2.2.4.5 Toe-off.....	7
2.2.5 Swing Phase	8
2.2.6 Alignment.....	8

Chapter three

Literature Review, and the Prosthetics in Sudan

3.1 Literature Review.....	9
3.2 prosthetics products and raw materials in Sudan	10
3.2.1 Hard sockets materials	10
3.2.1.1 Polypropylene (PP) socket	10
3.2.1.2 Resin socket	10
3.2.1.3 Endoflex socket.....	11
3.2.2 Soft sockets materials.....	11
3.2.2.1 Ethylene-Vinyl Acetate (EVA)	11
3.2.2.2 Liner	11
3.2.3 Feet.....	12
3.2.3.1 ICRC foot.....	12
3.2.3.2 Ottobock feet.....	12
3.3 Rehabilitation centres in Sudan.....	13
3.3.1 The governmental centres	13
3.3.1.1 National Authority for Prosthetics and Orthotics (NAPO)	13
3.3.1.2 Alamal centre	14

3.3.2 The private centres	14
3.3.3.1 Otad centre	14
3.3.3.2 Paramedic centre	14
3.4 Service providers of prosthetics manufacturing in Sudan.....	15
3.5 prosthetics manufactured per year	16

Chapter four

Methodology, Design, and Analysis

4.1 Methodology	17
4.2 The design	18
4.2.1 Height and foot segment calculation.....	19
4.2.2 The design dimensions	19
4.2.2.1 The socket adaptor	20
4.2.2.2 The core.....	21
4.2.2.3 The connector.....	21
4.2.2.4 The lower	21
4.2.2.5 The bolts.....	22
4.3 The analysis.....	22
4.4 Ground reaction force during gait cycle stages calculation	25
4.5 ISO 10328 tests load	26

Chapter five

Results, and Discussion

5.1 Mechanical analysis background	27
5.1.1 Total Deformation.....	27
5.1.2 Maximum principle elastic strain.....	27
5.1.3 Maximum principal (normal) stress	27
5.1.4 Equivalent (von-Mises) stress	27

5.1.5 Factor of safety.....	27
5.2 Results.....	28
5.2.1 Initial contact stage results.....	28
5.2.1.1 Total deformation.....	28
5.2.1.2 Maximum Principal Elastic Strain.....	29
5.2.1.3 Maximum Principal Stress.....	29
5.2.1.4 Equivalent Stress.....	30
5.2.2 Loading response stage results.....	31
5.2.2.1 Total deformation.....	31
5.2.2.3 Maximum Principal Elastic Strain.....	31
5.2.2.4 Maximum Principal Stress.....	32
5.2.2.5 Equivalent Stress.....	33
5.2.3 Midstance stage results.....	33
5.2.3.1 Total deformation.....	33
5.2.3.2 Maximum Principal Elastic Strain.....	34
5.2.3.3 Maximum Principal Stress.....	35
5.2.3.4 Equivalent Stress.....	35
5.2.4 Terminal Stance stage results.....	36
5.2.4.1 Total deformation.....	36
5.2.4.2 Maximum Principal Elastic Strain.....	37
5.2.4.3 Maximum Principal Stress.....	37
5.2.4.4 Equivalent Stress.....	38
5.2.5 Toe- off stage.....	39
5.2.5.1 Total deformation.....	39
5.2.5.2 Maximum Principal Elastic Strain.....	39
5.2.5.3 Maximum Principal Stress.....	40
5.2.5.4 Equivalent Stress.....	41

5.2.6 Safety factor	41
5.2.7 ISO test load results	42
5.2.7.1 Initial contact results	42
5.2.7.2 Toe-off results	43
5.3 Discussion	44
5.3.1 The cost calculation.....	45

Chapter six

Conclusion, and Recommendations

6.1 The design objectives	46
6.2 Merits and demerits of the design	46
6.3 Comparison between the design and other designs in Sudan	47
6.3.1 The design and NAPO design Comparison	47
6.3.2 The design and endoflex design Comparison	47
6.3.3 The design and private centres design Comparison	47
6.4 Conclusion	48
6.5 Recommendations	48
6.6 Future work	48
References	51

List of tables

Table	Page No
Table 4.1 Materials properties.	24
Table 5.1 maximum values of Total deformation in the initial contact stage for all materials.	28
Table 5.2 maximum values of Maximum Principal Elastic Strain in the initial contact stage for all materials.	29
Table 5.3 maximum values of Maximum Principal Stress in initial contact stage for all materials.	30
Table 5.4 maximum values of Equivalent Stress in initial contact stage for all materials.	31
Table 5.5 maximum values of Total deformation in loading response stage for all materials.	31
Table 5.6 maximum values of maximum Principal Stress in loading response stage for all materials.	32
Table 5.7 maximum values of maximum Principal Stress in loading response stage for all materials.	33
Table 5.8 maximum values of Equivalent Stress in loading response stage for all materials.	33
Table 5.9 maximum values of Total deformation in midstance stage for all materials.	34
Table 5.10 maximum values of Maximum Principal Elastic Strain in midstance stage for all materials.	35
Table 5.11 maximum values of maximum Principal Stress in Midstance stage for all materials.	35
Table 5.12 maximum values of Equivalent Stress in midstance stage for all materials.	36
Table 5.13 maximum values of Total deformation in terminal Stance stage for all materials.	37
Table 5.14 maximum values of Maximum Principal Elastic Strain in terminal Stance stage for all materials.	37

Table 5.15 maximum values of maximum Principal Stress in terminal Stance stage for all materials	38
Table 5.16 maximum values of Equivalent Stress in terminal Stance stage for all materials	39
Table 5.17 maximum values of Total deformation in the toe-off stage for all materials	39
Table 5.18 maximum values of Maximum Principal Elastic Strain in the toe-off stage for all materials	40
Table 5.19 maximum values of maximum Principal Stress in the toe-off stage for all materials	41
Table 5.20 maximum values of Equivalent Stress in the toe-off stage for all materials	41
Table 5.21 minimum values of safety factor in all stage for (stainless steel + titanium alloy)	42
Table 5.22 the maximum and minimum values of ISO load test in the initial contact stage for (Stainless steel+ titanium) materials.	43
Table 5.23 the maximum and minimum values of ISO load test in the toe-off stage for (Stainless steel+ titanium) materials.	44

List of figures

Figure	Page No
Fig 1.1 levels of amputations according to NAPO statistics between 2013 and 2015 for Khartoum on PMS_KHA.	1
Fig 2.1 terminologies of the gait cycle.	4
Fig 2.2 Phases of the gait cycle.	5
Fig 2.3 stance phase component.	5
Fig 2.4 (a) initial contact period right foot, (b) and GRF vector position.	6
Fig 2.5 (a) loading response stage, (b) and the GRF vector position.	6
Fig 2.6 (a) midstance stage, (b) and the vector of GRF position.	7
Fig 2.7 (a) terminal stance stage, (b) and the vector of GRF.	7
Fig 2.8 (a) preswing period the beginning, (b) and the ending and the vector of GRF.	7
Fig 2.9 components of swing phase.	8
Fig 2.10 sagittal plane alignment.	8
Fig 3.1 hard sockets. (a) white polypropylene, (b) terra polypropylene, (c) resin sockets and (d) endoflex socket used in paramedic centre.	11
Fig 3.2 soft sockets. (a) EVA, (b) copolymer liner.	12
Fig 3.3 (a) ICRC foot, (b) dog-tailed keel.	12
Fig 3.4 Ottobock feet. (a) SACH, and (b) dynamic feet.	12
Fig 3.5 transtibial prosthesis in Sudan. (a and b) Paramedic centre prosthesis, and (c) ICRC prosthesis.	15
Fig 4.1 methodology flow chart.	17
Fig 4.2 the design.	18
Fig 4.3 the average of human body segments lengths.	19
Fig 4.4 the design dimensions. (a) bottom, front, and right view, (b) the bottom view, (c) the front view and (e) the right view, and (e) design alignment.	20
Fig 4.5 The socket adaptor. (a) The left view, and (b) the front view.	20
Fig 4.6 the core. (a) The right view, and (b) the front view.	21
Fig 4.7 the connector. (a) The front view, (b) the left view, and (c) the bottom view.	21

Fig 4.8 the lower. (a) The front view, (b) the bottom view, and (c) the left view.	22
Fig 4.9 the front view of bolts. (a) Bolt 1(B1), (b) bolt 2 (B2), and (c) bolt 3 and bolt 4 (B3 and B4).....	22
Fig 4.10 the meshed design.....	23
Fig 4.11 faces positions bottom view. (a) Initial contact, (b) loading response, (c) midstance, (d) terminal stance, and (e) toe-off stages.....	24
Fig 4.12 boundary conditions. (a) Stance phase stages, and (b) ISO test load.	25
Fig 4.13 curve of vertical ground reaction force left and right legs.....	25
Fig 5.1 Total deformation in the initial contact stage for all materials. (a) Aluminium alloy, (b) Stainless steel, (c) Titanium alloy, and (d) (Stainless steel + Titanium alloy) materials.....	28
Fig 5.2 Maximum Principal Elastic Strain in the initial contact stage for all materials. (a) Aluminium alloy, (b) Stainless steel, (c) Titanium alloy, and (d) (Stainless steel + Titanium alloy) materials.....	29
Fig 5.3 Maximum Principal Stress in initial contact stage for all materials. (a) Aluminium alloy, (b) Stainless steel, (c) Titanium alloy, and (d) (Stainless steel + Titanium alloy) materials.....	30
Fig 5.4 Equivalent Stress in initial contact stage for all materials. (a) Aluminium alloy, (b) Stainless steel, (c) Titanium alloy, and (d) (Stainless steel + Titanium alloy) materials.....	30
Fig 5.5 Total deformation in loading response stage for all materials. (a) Aluminium alloy, (b) Stainless steel, (c) Titanium alloy, and (d) (Stainless steel + Titanium alloy) materials.....	31
Fig 5.6 Maximum Principal Elastic Strain in loading response stage for all materials. (a) Aluminium alloy, (b) Stainless steel, (c) Titanium alloy, and (d) (Stainless steel + Titanium alloy) materials.....	32
Fig 5.7 Maximum Principal Stress in loading response stage for all materials. (a) Aluminium alloy, (b) Stainless steel, (c) Titanium alloy, and (d) (Stainless steel + Titanium alloy) materials.....	32
Fig 5.8 Equivalent Stress in loading response stage for all materials. (a) Aluminium alloy, (b) Stainless steel, (c) Titanium alloy, and (d) (Stainless steel + Titanium alloy) materials.....	33

Fig 5.9 Total deformation in midstance stage for all materials. (a) Aluminium alloy, (b) Stainless steel, (c) Titanium alloy, and (d) (Stainless steel + Titanium alloy) materials.	34
Fig 5.10 Maximum Principal Elastic Strain in midstance stage for all materials. (a) Aluminium alloy, (b) Stainless steel, (c) Titanium alloy, and (d) (Stainless steel + Titanium alloy) Maximum materials.	34
Fig 5.11 Maximum Principal Stress in Midstance stage for all materials. (a) Aluminium alloy, (b) Stainless steel, (c) Titanium alloy, and (d) (Stainless steel + Titanium alloy) materials.	35
Fig 5.12 Equivalent Stress in midstance stage for all materials. (a) Aluminium alloy, (b) Stainless steel, (c) Titanium alloy, and (d) (Stainless steel + Titanium alloy) materials.	36
Fig 5.13 Total deformation in terminal Stance stage for all materials. (a) Aluminium alloy, (b) Stainless steel, (c) Titanium alloy, and (d) (Stainless steel + Titanium alloy) materials.	36
Fig 5.14 Maximum Principal Elastic Strain in terminal Stance stage for all materials. (a) Aluminium alloy, (b) Stainless steel, (c) Titanium alloy, and (d) (Stainless steel + Titanium alloy) materials.	37
Fig 5.15 Maximum Principal Stress in terminal Stance stage for all materials. (a) Aluminium alloy, (b) Stainless steel, (c) Titanium alloy, and (d) (Stainless steel + Titanium alloy) materials.	38
Fig 5.16 Equivalent Stress in terminal Stance stage for all materials. (a) Aluminium alloy, (b) Stainless steel, (c) Titanium alloy, and (d) (Stainless steel + Titanium alloy) materials.	38
Fig 5. 17 Total deformations in the toe-off stage for all materials. (a) Aluminium alloy, (b) Stainless steel, (c) Titanium alloy, and (d) (Stainless steel + Titanium alloy) materials.	39
Fig 5.18 Maximum Principal Elastic Strain in the toe-off stage for all materials. (a) Aluminium alloy, (b) Stainless steel, (c) Titanium alloy, and (d) (Stainless steel + Titanium alloy) materials.	40
Fig 5.19 Maximum Principal Stress in the toe-off stage for all materials. (a) Aluminium alloy, (b) Stainless steel, (c) Titanium alloy, and (d) (Stainless steel + Titanium alloy) materials.	40

Fig 5.20 Equivalent Stress in the toe-off stage for all materials. (a) Aluminium alloy, (b) Stainless steel, (c) Titanium alloy, and (d) (Stainless steel + Titanium alloy) materials.	41
Fig 5.21 safety factor in all stage for (stainless steel + titanium alloy). (a) Initial contact, (b) loading response, (c) midstance, (d) terminal stance, and (d) toe-off stages.	42
Fig 5.22 ISO load test in the initial contact stage for (Stainless steel+ titanium). (a) Total deformation, (b) equivalent stress, (c) maximum Principal stress, and (d) factor of safety.....	43
Fig 5.23 ISO load tests in the toe-off stage for (Stainless steel+ titanium). (a) Total deformation, (b) equivalent stress, (c) maximum Principal stress, and (d) factor of safety.	44

Chapter One

General Overview

1.1 Introduction

Statistically, the most common level of amputation in the world and in Sudan as well is transtibial (below knee) amputation [1]. Fig 1.1 shows the levels of amputations according to National Authority for Prosthetics and Orthotics (NAPO) between 2013 and 2015.

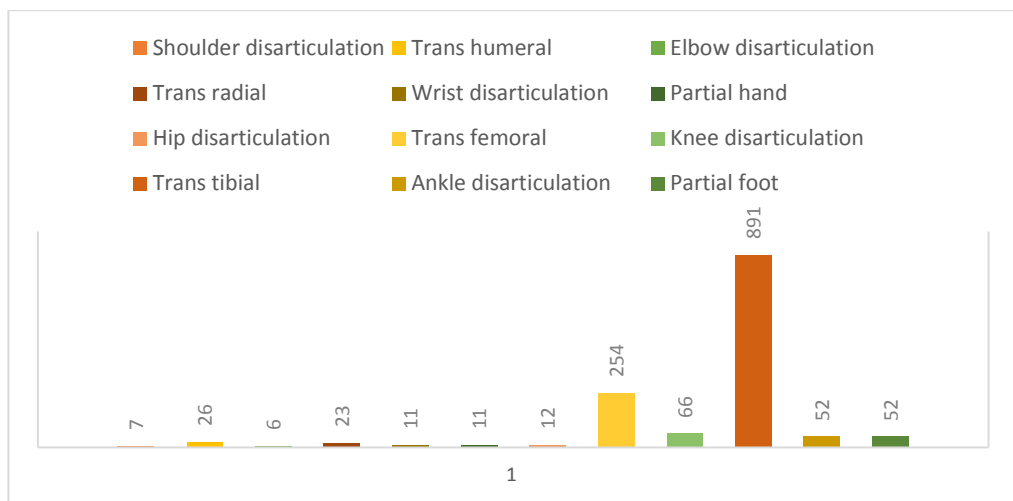

Fig 1.1 levels of amputations according to NAPO statistics between 2013 and 2015 for Khartoum on PMS_KHA.

In Sudan the transtibial prosthesis is provided by the governmental centres which supply their patients with International Committee of Red Cross (ICRC) technology, there are orientations nowadays to enter other technology but this has not executed yet, besides, there are also private centres which provide to the patients mainly Ottobock technology and other technologies on demands.

The prosthetic foot represents the most important component in prosthetic limb [2], indeed, there is demand for design prosthetic feet in Sudan from materials can be available locally as possible which will help to expand the choices, and be a choice for those who cannot afford to buy high-cost components.

Finite element analysis (FEA) is the method used to solve complex problems and systems to approximate the physical behaviour of that system using different

equations, this method saves time and cost, can be applied in different fields, and it is popular between designers engineers from all disciplines[3, 4, 5].

In this thesis, the selection of the foot design materials was based on the needs of the developing countries like aluminium alloy, stainless steel, and some of them due to design needs such as titanium alloy, and lastly two materials stainless steel in some parts, and titanium alloy in other parts.

Aluminium alloy is Lightweight, ductile malleable and good strength to weight ratio material [6, 7]. Stainless steel can be recycled, tough, durable material [8]. Titanium alloy is high strength to weight ratio, high strength, lightweight material [9, 10].

Five biomechanical analysis for the design was done total deformation, maximum equivalent stress, maximum principal stress, maximum principle elastic strain, and lastly safety factor.

1.2 Problem Statement

Prosthetics manufacturing in Sudan depends only on imported components and technologies, the components are either high cost with high function or low cost but its function is not good.

1.2.1 Solution

Making surveys and researches to determine the obstacles of not manufacturing local prosthetic products, after that design a lot of prosthetics models that are applicable, can be manufactured and distributed in the market.

1.3 Objectives

This thesis aims to design prosthetic foot for transtibial amputees by using different kinds of materials and compare between them, and the possibility of using them in such applications, indeed, this thesis will go through some areas that will comprise.

1.3.1 General objective

Design prosthetic foot.

1.3.2 Specific objectives

Design prosthetic foot from metals.

Design prosthetic foot suitable for transtibial amputees their mass is below 60 kg and their foot length is 24 cm.

Design prosthetic foot easy to assembly.

Analysis of the designed prosthetic foot using FEA method.

1.4 Thesis layout

This thesis consists of six chapters. **Chapter one** is a general overview of the problems, the solution, and objectives of the thesis. **Chapter two** is a theoretical background of the thesis. **Chapter three** is a literature review of the thesis, and the prosthetics products existing in Sudan. **Chapter four** is the methodology, the design and analysis of the design. **Chapter five** is the results obtained from analysis and discussion. **Chapter six** is **the** conclusion of the thesis, recommendations, and future work.

Chapter two Theoretical Background

2.1 Ground reaction force (GRF)

Is the generated force when foot contacts the ground as a reaction of the ground to balance the internal forces and this happened in stance phase, it considered as important external force effects on the joints of the body, the reduction of its value causes problems in the joints due the reduction of the forces on the joints [11].

2.2 The Gait

Normal walking is manner where one foot is on the ground, and the other not this activity makes the body moves forward.

Gait is the process or style of walking, and it differentiates the individual from other people, even though everyone has its unique normal gait yet the steps or components are same for all human being [12, 13].

2.2.1 Gait cycle (stride)

It is the repetition of touching of the left, or the right foot the ground after some time again (Fig 2.1).

2.2.2 A stride length

The distance between left foot heel strike and right foot heel strike is called right step length (Fig 2.1) and between the right heel strike and the left heel strike is left step length, the summation of both of them is called stride length [12].

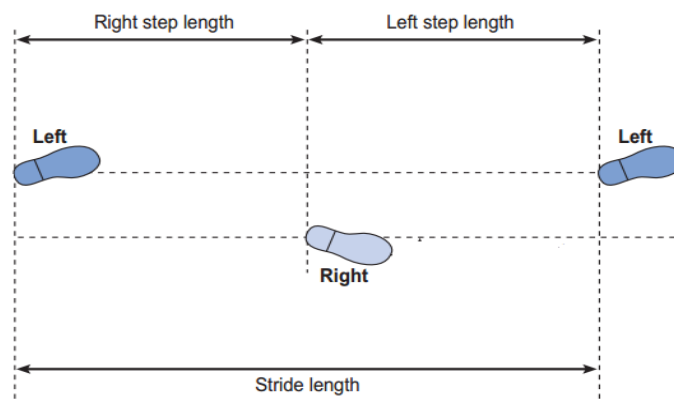

Fig 2.1 terminologies of the gait cycle [13].

2.2.3 Walking speed

When a person walks for a distance, the steps number taken per minute is called walking speed, it increases with fast walking and decreases with slow walking. The period when both the left and right foot on the ground is called double support periods when only one foot on the ground and other not is single support period (Fig 2.2) [12, 13].

Walking terminologies are described by traditional terms which refer to points in time, and other terms refer to periods of time this belong to the Gait Laboratory at Rancho Los Amigos (RLA) Medical Center [12].

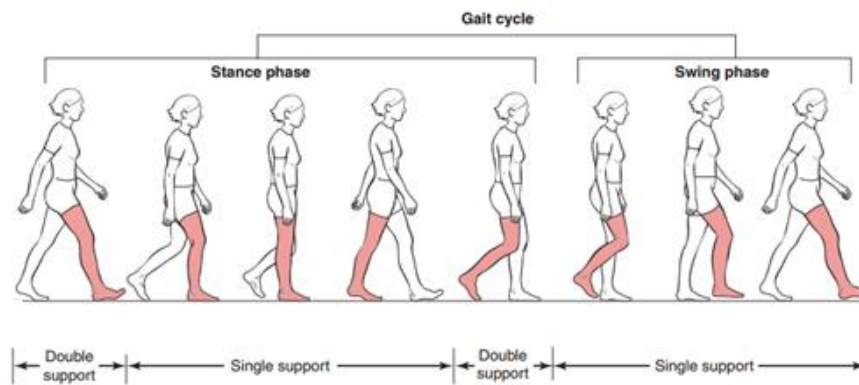

Fig 2.2 Phases of the gait cycle [12].

2.4.4 Stance Phase

It represents 60 % of the gait cycle and it is when the foot is on the ground. It begins with the heel strike of one foot and ends when that foot leaves the ground. The stance phase is divided into five stages (Fig 2.3) [12].

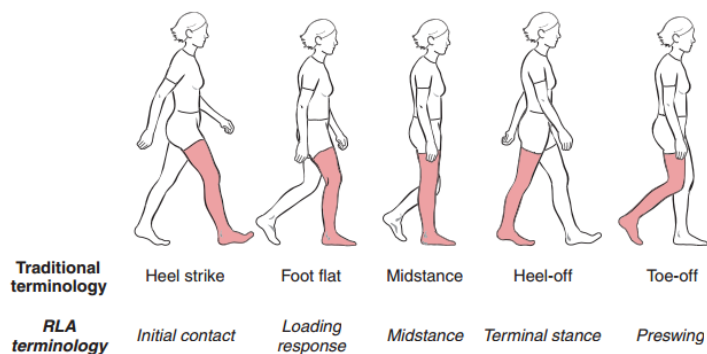

Fig 2.3 stance phase component [12].

2.2.4.1 Heel strike

Stance phase begins with this component, it is also called initial contact, and here heel starts contacting the ground. (Fig 2.4) the initial contact stage for the right leg, and the vector of the ground reaction force position (GRF) [12, 13].

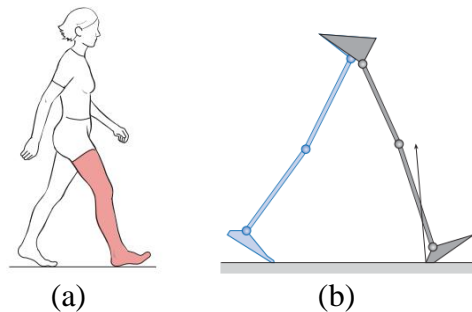

Fig 2.4 (a) initial contact period right foot, (b) and GRF vector position [12, 13].

2.2.4.2 Foot flat

It is also called loading response, it occurred after heel strike and here the whole foot contacting with the ground. (Fig 2.5) the beginning and end of the loading response stage, and the vector of the ground reaction force position [12, 13].

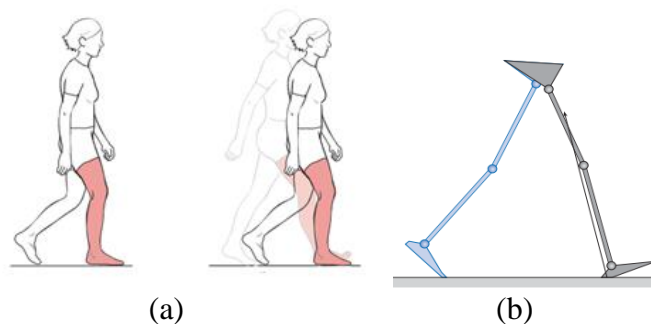

Fig 2.5 (a) loading response stage, (b) and the GRF vector position [12, 13].

2.2.4.3 Midstance

It starts after loading response and in this period the weight bearing of the body happened. (Fig 2.6) the beginning and end of the midstance stage, and the vector of the ground reaction force position [12, 13].

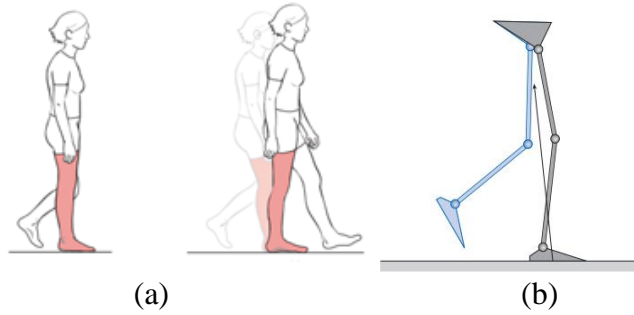

Fig 2.6 (a) midstance stage, (b) and the vector of GRF position [12, 13].

2.2.4.4 Heel-off

It is also called terminal stance, the heel is lifted from the ground in this period. (Fig 2.7) the beginning and end of the terminal stance stage, and the vector of the ground reaction force position [12, 13].

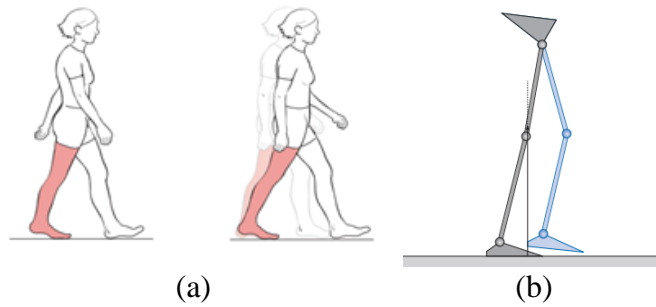

Fig 2.7 (a) terminal stance stage, (b) and the vector of GRF [12, 13].

2.2.4.5 Toe-off

It is called preswing, this period represents the beginning of the swing phase. (Fig 2.8) the beginning and end of the preswing stage, and the vector of the ground reaction force (GRF) position [12, 13].

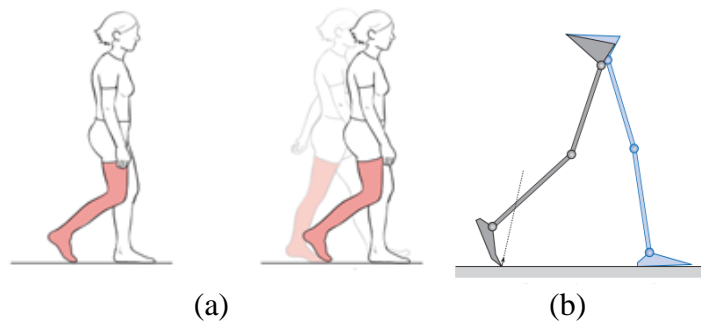

Fig 2.8 (a) preswing period the beginning, (b) and the ending and the vector of GRF [12,13].

2.2.5 Swing Phase

The advancement happened in this stance, and it starts after toe-off, at the beginning of it the foot is not anymore in contact with the ground yet at the end of it the foot touches the floor once again. (Fig 2.9) it composed of three stages acceleration (initial swing), midswing, and deceleration (terminal swing), during this stance the ground reaction force is equal to zero [12, 13].

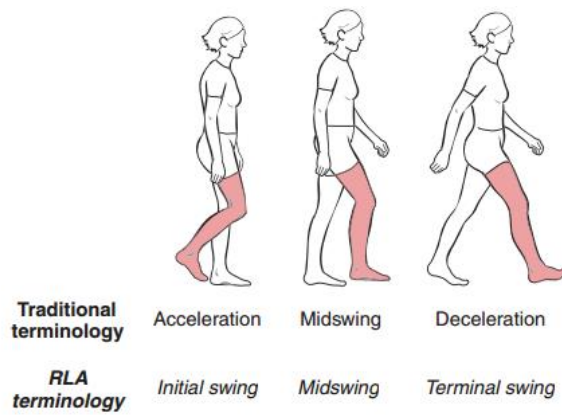

Fig 2.9 components of swing phase [12].

2.2.6 Alignment

Is the relation between prosthesis components and the socket (Fig 2.10). It mimics the normal pattern of gait, and it reduces the undesired forces on the stump [14, 15].

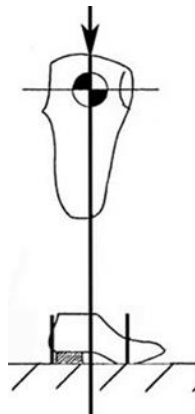

Fig 2.10 sagittal plane alignment [14].

Chapter three

Literature Review, and the Prosthetics in Sudan

3.1 Literature Review

The literature addressing the most consideration to put in mind when designing for developing countries, the feet which were made from metals, and lately, the transtibial prosthetics and the technologies found in Sudan.

Cheng (2004) made adjustable Bicycle Limb from material available in developing countries, the leg is built from the foot which is made from wood and up to the socket, the shank has two part the cylindrical part and the other part in the back which is composed of two sections connected with bolt to make shank adjustable, foot is connected to the shank with bolts [16].

Nicholas G et al. (2010) made a prosthetic foot for the developing countries made of moderate carbon steel divided into two parts, the front part is divided into two parts between them there is a rubber, the other part is C-shape and there is also rubber, this foot is attached to cylindrical shank [17].

Albert E et al. (2012) designed adjustable aluminium shank for children and adult, the ankle joint is made of stainless steel, the foot is divided into two parts the frontal part of is from wood, and the second part is a part of the stainless steel ankle [18].

Taahirah et al. (2015) addressed in their paper the metal alloys and the possibility of using them in developing countries to manufacture prosthetics for pediatric [19].

Martin et al. (2015) concluded the biggest problem faces the organizations supply the low-income countries with prosthetic devices as a lack of funding to provide accessible prosthetic devices at affordable price, the other thing is most of the prosthetic devices come from western countries which are unsuitable for those who are living in another environment which leads to increasing of devices repair, and there is a lack of service providers of prosthetics manufacturing, that is why designing devices for developing countries is an essential issue the low cost and being environmentally suitable should put into consideration when designing [20].

Laferrier et al. (2018) in their review paper said that the transtibial prosthetic feet manufacturing is in continuous improvement via the last decades yet developing countries do not benefit from these advanced technologies for many reasons, the

points need to giving attention, and concern when designing and manufacturing prosthetics is the prosthetic feet it should be durable, economic, and biomechanically appropriate, add to that accessibility of these components options and the ease of maintenance are high issue. The majority of feet used in developing countries are not the local origin, not suitable for environment consideration and there is important issue designers should put in minds such as ease of local manufacturing and fabrication process, and they suggested constructing using simple tools like cutting and injection modelling [21].

3.2 prosthetics products and raw materials in Sudan

The products and the raw material of prosthetics in Sudan are brought from outside either from companies dealing with them directly or from organization brings the products by their own way, so we can say products come from two destinations only the first one is ICRC an organization working in many fields and one of them is prosthetics supplying in the places where there is war. It has its own technique depends on polypropylene technology, it is executed their products by CR equipment company. The second one is Ottobock a German company, its products are of high quality.

3.2.1 Hard sockets materials

In rehabilitation centres in Sudan, there are two materials used in the fabrication of sockets.

3.2.1.1 Polypropylene (PP) socket

Polypropylene is a thermoplastic material, this material tends to stretch when heated because the molecules distance increases due to the high dilation coefficient. And when forming the socket this thing should be put into consideration because the excessive temperature can make the socket not as should be and this can affect the quality of it [22].

In Sudan PP which is used in prosthetics, manufacturing is terra polypropylene of ICRC this the most common one, the other one is white polypropylene (Fig 3.1).

3.2.1.2 Resin socket

The resin is a composite material it is usually made up fibre as reinforcement and resin as a matrix. The mechanical properties of these materials, the fibre length, the position, the fabricating and ratio of the materials all these effects on the quality of the composite [23].

Ottobock 80:20 Orthocryl lamination resin is the kind which is used in Sudan in manufacturing sockets (Fig 3.1), it is colourless and viscous material, it takes its colour after mixing with the hardener and the colour paste [24].

3.2.1.3 Endoflex socket

A combination of socket and pylon using one material is called endoflex (monolimb), it is low cost comparing to the composite materials, and can be connected to many kinds of feet, it has advantages of shear and stress absorption and it provides flexibility as well [25]. (Fig 3.1) the material used in fabricating endoflex here in Sudan is white polypropylene.

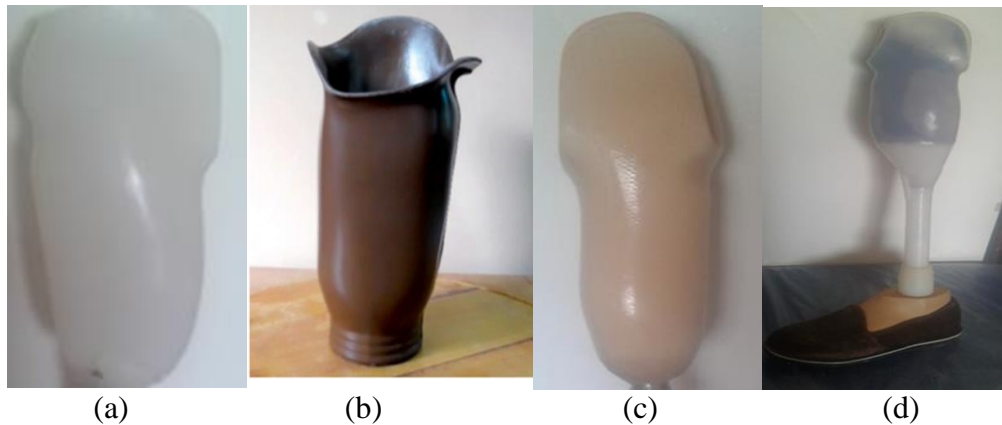

Fig 3.1 hard sockets. (a) white polypropylene, (b) terra polypropylene, (c) resin sockets and (d) endoflex socket used in paramedic centre.

3.2.2 Soft sockets materials

There are two materials used in the manufacturing of soft sockets in Sudan.

3.2.2.1 Ethylene-Vinyl Acetate (EVA)

It is a non-toxic polymer material, used in many applications, it manufactured by using thermoplastic methods (Fig 3.2), this material is resistant to moisture and chemicals which make it a good choice in this application [26].

3.2.2.2 Liner

Copolymer liner (Fig 3.2) is the kind which is found in Sudan, it is copolymer covered with textile, antitoxic and it moisturizes the skin due to medical oil, it is used with shuttle-lock suspension [24]. Fig 3.4 shows the Ottobock copolymer liner used in Sudan.



Fig 3.2 soft sockets. (a) EVA, (b) copolymer liner.

3.2.3 Feet

The feet in Sudan are three kinds.

3.2.3.1 ICRC foot

This foot is Solid Ankle Cushion Heel (SACH) foot, this foot is made of dog-tailed keel made of polypropylene plastic which is the cushion part surrounded by polyurethane foam [27], and it is attached to the shank using a bolt (Fig 3.3). This foot needs to be changed frequently after a year and sometimes less.



Fig 3.3 (a) ICRC foot, (b) dog-tailed keel.

3.2.3.2 Ottobock feet

Ottobock SACH foot is the second type available in Sudan, it is made of a fibreglass-reinforced plastic core and the foam is functional, it is different in shapes and heights. The other kind of feet also from Ottobock is 1D35 a dynamic foot, it is made of rollover carbon fibre, and it offers for the amputee a gait near to the natural [24]. (Fig 3.6) shows Ottobock feet in Sudan.



Fig 3.4 Ottobock feet. (a) SACH, and (b) dynamic feet [24].

3.3 Rehabilitation centres in Sudan

Rehabilitation centres in Sudan are divided into two governmental and private centres, the technologies, and the prices are different between them as well as the quality of the materials.

3.3.1 The governmental centres

In Khartoum there are two centres are working in the fabrication of prosthetics, and twelve centres in Sudan states which are in Senga, Algenena, Alobeed, Atbra, Madani, Dongola, Kassala, Gadaref, Al damazin, Alfasher, Kadogly, and Nyala states.

3.3.1.1 National Authority for Prosthetics and Orthotics (NAPO)

It is the first governmental destination responsible of prosthetics and orthotics in all Sudan, firstly it was a national centre for prosthetics, and it was for civilian and military patients as well as service providers, then it became for civilians only and the name of it became the national authority for prosthetics and orthotics. It was under the supervision of the ministry of health. Now it is under the supervision of the ministry of social affairs.

This authority provides some services makes it distinguish than other centres such as mobile workshop which is a special car designed in Giad, and it contains all the tools needed for manufacturing prosthetic, this car goes to the states and provide services to whom cannot come to Khartoum and get rehabilitation services. Secondly, construction of the rehabilitation centres in Sudan states opened by NAPO in collaboration with the government states and the technical guidance from ICRC. Thirdly, providing periodic training courses for the new technician assistance in collaboration with ICRC.

In the past, the components which are used in NAPO were from Ottobock Company, and the socket was manufactured using resin when WHO was responsible for supplying products, Nowadays, the provider of products is ICRC, and its technology is also adapted in all the states centres.

The other technology which is going to be adapted, and it will be on demand only is resin sockets, the tools for manufacturing this technology had been installed, but the work has not started yet. In NAPO the soft socket is EVA, the foot is ICRC SACH foot, and the pylon and socket are from polypropylene.

ICRC transtibial prosthetic is composed of a bolt connects the SACH foot to the ankle, the ankle is connected to the shank which is two cylindrical parts connects together by

welding them, the hard socket is connected to the shank and cup by bolt and washer (Fig 3.5) [28].

3.3.1.2 Alamal centre

There is another governmental rehabilitation centre in Alamal city, this foundation belongs to the military authority. The military separated from NAPO, and the technicians who are not civilian went to this centre and the service was provided to the military citizens only yet now is open for all citizens. The material which is used in the past to manufacture the socket is resin but now they use monolimb white polypropylene, in Sudan, this prosthesis is known as the white prosthesis.

3.3.2 The private centres

There are two private centres provides prosthetics in Sudan, these centres provide products to patients with demands, and this means they import products due to the request of the patient.

3.3.3.1 Otad centre

It is the first private centre in Sudan specialized in rehabilitation, this centre provides all services of prosthetics and orthotics. It is the second centre used endoflex technology after Alamal centre but there is a difference between the white polypropylene quality used in these centres as well as the foot adaptor shape is also different. The socket in Otad is manufactured from resin and white polypropylene depending upon the demand of the patient. The soft socket is EVA or copolymer liner. The foot which this centre provides is mainly SACH foot.

3.3.3.2 Paramedic centre

This is a new private centre, the special thing in this centre is all the tools and equipments used in it are from Sudan, as for the raw material are from outside Sudan mainly from Ottobock Company.

The materials which are available in this centre is the same in Otad centre when it was opened because the founder is the same person, there is a difference also depending upon the demand of patients. (Fig 3.5) This centre used white polypropylene as well as a resin for sockets, the soft sockets are liner and EVA, the pylon is from aluminium, and the adaptor is from titanium or aluminium.

Teflon sheet is used to manufacture the foot adaptors for the monolimb prosthetics, and it manufactured locally, the feet which are used in this centre are Ottobock SACH foot, and the dynamic foot from the same company.

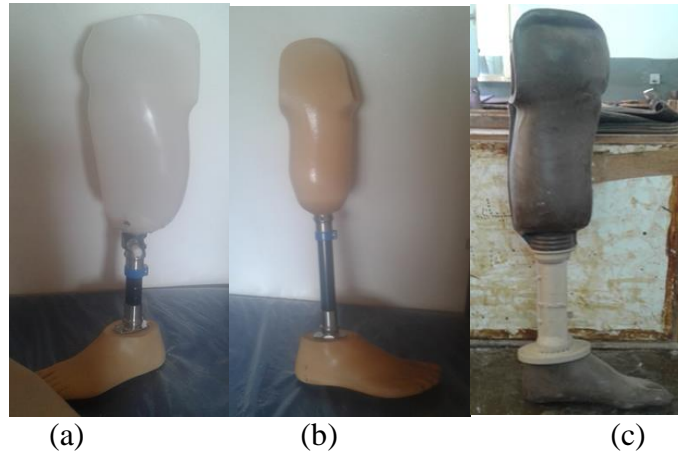

Fig 3.5 trans-tibial prosthesis in Sudan. (a and b) Paramedic centre prosthesis, and (c) ICRC prosthesis.

3.4 Service providers of prosthetics manufacturing in Sudan

Persons who work in manufacturing of prosthetics and orthotics are divided due to the education they took, the names of their jobs is international yet the difference is in the level of education, this means due to local needs the service providers are getting involved in tasks they are not allowed to do them with this level of education, yet the course they took upgraded them, and the lack of service providers obliges to do so. **Prosthetists** are persons who studied a bachelor of prosthetics and orthotics science, these persons supervise the other service provider, and can deal with the patient directly. There is only two prosthetist in Sudan.

Technologists are persons who studied diploma of prosthetics and orthotics science either they took their education inside or outside Sudan. These persons can deal with the patient directly also. Their number is nineteen and seven of them are now working out of Sudan.

Technicians are persons who worked for many years in the field of manufacturing of prosthetics and orthotics, and then took a course for about a year in the field, and some of them have not taken any course, but they worked for more than ten years. These persons can take the cast from patients and deal with them directly. Their number is forty-three.

Technician assistants are persons took a course for about six or three months in the field, and there are others working by experience only, and they do not take any course. These persons are not allowed to deal with patients or even amend the socket, their

work starts only after finishing the shaping of the casting stage. The number of them is forty-one.

Engineers, there are different engineers from different specializations working for NAPO, three mechanical engineers, seven biomedical engineers, two medical instrumentation engineers, and four leather engineers. These engineers do not get involved in manufacturing process their role is still as administrative due to lack of training in the manufacturing process.

3.5 prosthetics manufactured per year

As long as NAPO has the biggest number of patients come to it, and they have system PMS for prosthetics and orthotics statistics, the other centres do not have statistics to depend on, we will depend upon NAPO statistics only.

There is now approximately 30900 patients has all types of prosthetic and orthotics devices, the average of patients of all prosthetic types who come and considered as new patients are 17 per week, and 816 per year, technicians and technologists numbers are 40 in all the branches of NAPO, and 32 technician assistants in all the branches of NAPO, some of these technicians and technologists are working in manufacturing orthotics only this can be about 10 which means 30 technicians and technologists are working to manufacturing prosthetics, this means about 28 patients at least for every technician and technologists, let alone the patients who come to make a new prosthetic because after 2 years the prosthetic almost need to be changed. The technician assistant works in assembling, amending, and finishing the new prosthetics and all the maintenance works for all the new and old cases this means also for every assistance there are about 25 new cases.

The price of the transtibial prosthetics in NAPO starts with 3500 SDG which means 2,856000SDG if we assume all the prosthetics are lower limbs only, and by the upcoming year, there are trends to increase the prices.

Chapter four Methodology, Design, and Analysis

4.1 Methodology

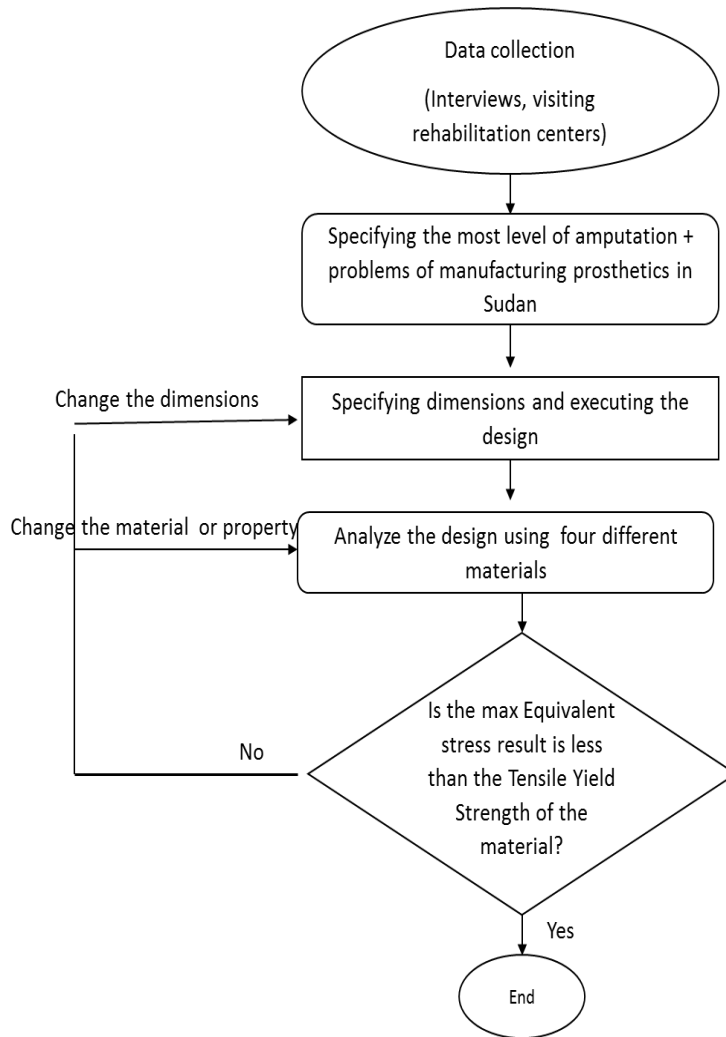

Fig 4.1 methodology flow chart.

Fig 4.1 represents the whole methodology had been executed via this thesis, firstly data had been collected from visiting three rehabilitation centres in Khartoum state which are NAPO, Otad and paramedic centres, interviews had been made with people who get involved in prosthetics manufacturing to determine the most common level of amputations and the manufacturing problems of prosthetics in Sudan, transtibial amputation had been determined as the most common level of amputations, the

problems which had been classified as the biggest problem in the governmental centres is torn of ICRC foot which costs 1500 SDG, and then there are other problems like the governmental centres depends on ICRC provider only, add to that the lack of the service providers. The high cost of prosthetics had been determined as the biggest problem in private centres.

Secondly, the dimensions of the design had been determined and sketched using SOLIDWORKS 2016 program to make the design of foot.

Thirdly the design had been imported to ANSYS 15.0 program to be analyzed using four different materials.

Lastly, the dimensions and materials properties had been changed many times until reaching to max equivalent stress result in less than the tensile yield strength of the material in all stages.

4.2 The design

Javelin prosthetic foot had been chosen to be the executed design, this foot is composed of pylon and foot as one part, and it is connected to hard socket material to be worn by transtibial amputees [29]. (Fig 4.2) shows the whole design had been executed which composed of four parts connected via four bolts.

This design can be a choice for the Sudanese amputees in addition to the existing designs, the original design made from E carbon spring material which is not available locally, it cost is considered as high comparing to metals except titanium alloy [30], besides, it is one of the materials needs from the workers to reduce exposure to it (Seung 2018)[31] and here in Sudan workers do not abide by safety guidelines, as long as looking for material which can be found locally or even easy to be imported was priority, metals had been used in this design for entering in many application manufacturing, moreover, they can be recyclable from scraps [32], and can be manufactured locally.

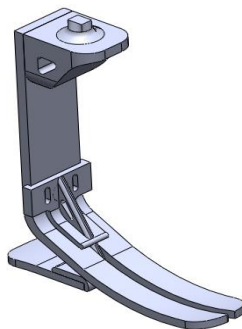

Fig 4.2 the design.

Anthropometry is the science of studying human body physical measurements, and it is essential in biomechanics analysis for it makes data as standard to be applied for every person, and from this data, every length segment of the human body can be predicted from subject height ratio (Fig 4.3) [33].

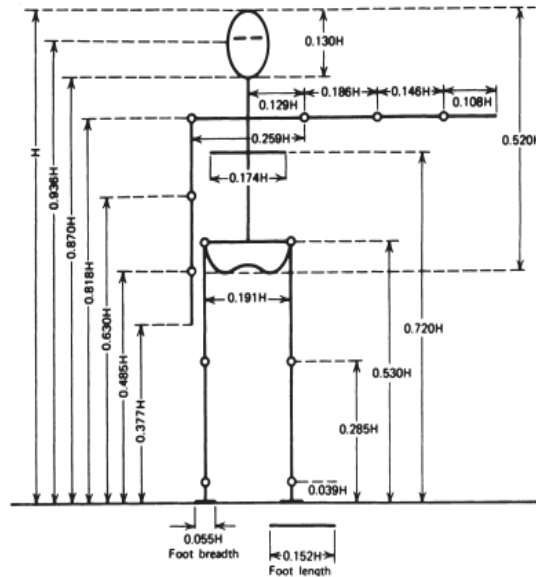

Fig 4.3 the average of human body segments lengths [33].

4.2.1 Height and foot segment calculation

From (Fig 4.3) and knowing that the length of the foot is 24 cm the following calculation had been done:

$$L = 0.152 \times H, \text{ then } H = 24 / 0.152 = 158 \text{ cm.}$$

$$B = .055 \times H = .055 \times 158 = 8.69 \text{ cm [33].}$$

Where L is the foot length, H is the height of the subject, and B is the foot breadth.

B value had been put in mind when designing, where the prosthetic foot width was less than this value to leave some space the foam in the future work.

4.2.2 The design dimensions

The dimensions of the design had been determined from javelin foot design, others are taken after analyzing the design and then it had been altered until reaching to the suitable dimensions, putting in mind anthropometry data especially for the foot width and length dimensions to not be exceeded, and the alignment line as well. The program had been used to make the foot design is SOLIDWORKS 2016. The parts had been sketched separately and then assembled to give the whole design (Fig 4.4), the dimensions are in millimetres.

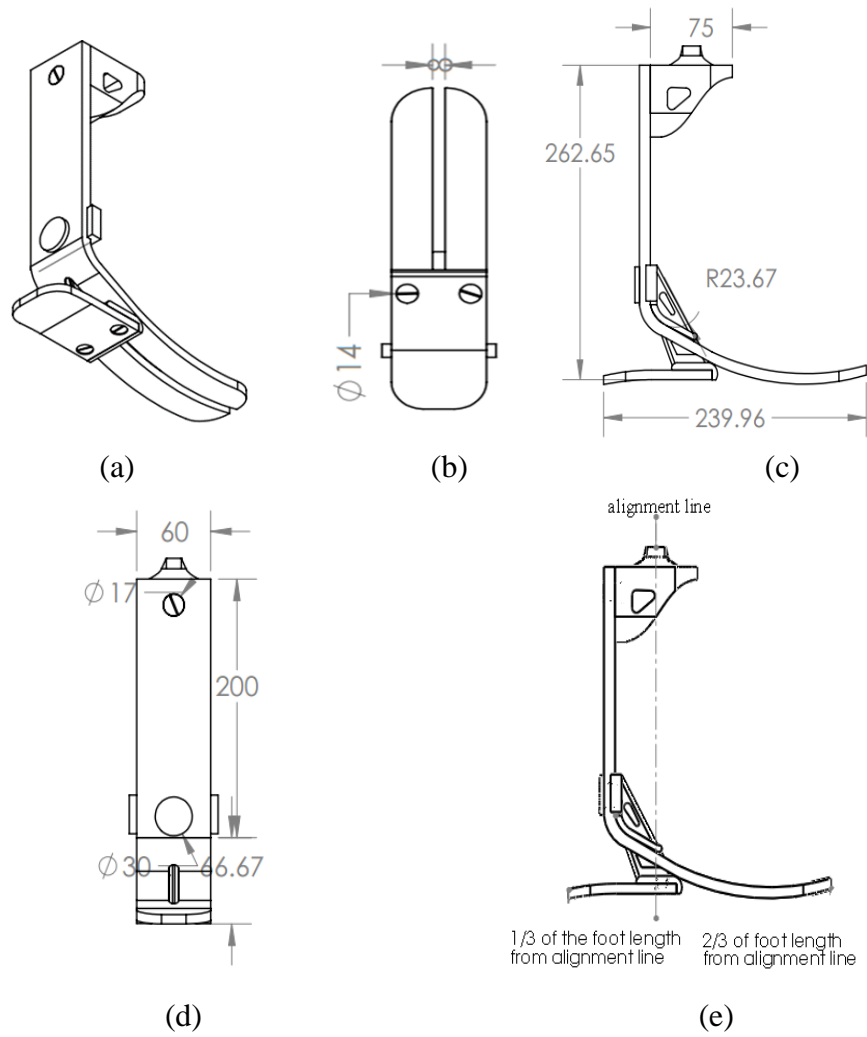

Fig 4.4 the design dimensions. (a) bottom, front, and right view, (b) the bottom view, (c) the front view and (e) the right view, and (e) design alignment.

4.2.2.1 The socket adaptor

Is the part used to connect the pylon (shank) to the transtibial socket (Fig 4.5), and it is connected to the core part via one bolt which is B1.

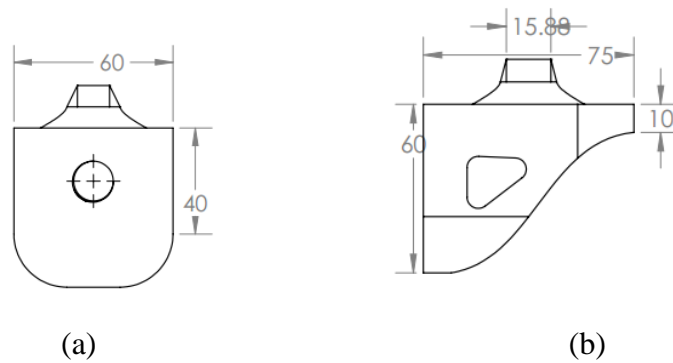

Fig 4.5 The socket adaptor. (a) The left view, and (b) the front view.

4.2.2.2 The core

This part is the main part of the design which composed of the pylon and the frontal part of the foot (Fig 4.6).

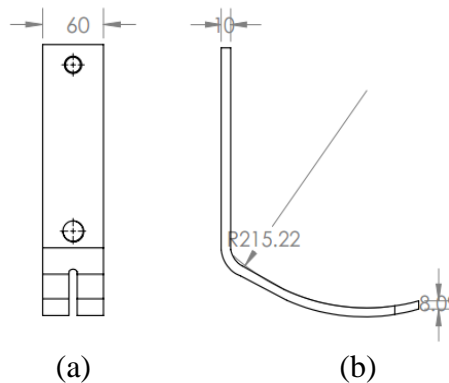

Fig 4.6 the core. (a) The right view, and (b) the front view.

4.2.2.3 The connector

This part plays a vital role because it is connected to two parts the core part, and the lower part. it is connected to the second part of the foot (the lower part) via two bolts B3 and B4, as well as it is connected to the core part via one bolt B2 (Fig 4.7).

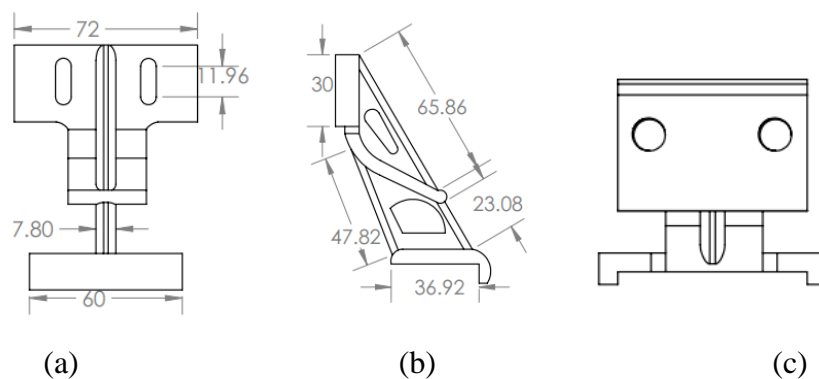

Fig 4.7 the connector. (a) The front view, (b) the left view, and (c) the bottom view.

4.2.2.4 The lower

This part represents the second part of the foot, and it is connected to the connector via two bolts B3 and B4 (Fig 4.8).

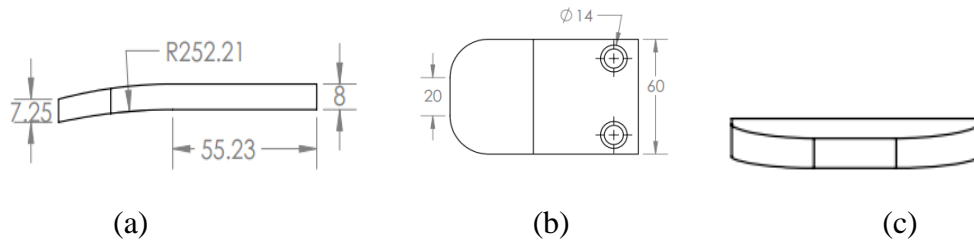

Fig 4.8 the lower. (a) The front view, (b) the bottom view, and (c) the left view.

4.2.2.5 The bolts

In this design we have four bolts (Fig 4.9), bolt 1 (B1) connects the socket adaptor part to the core part, bolt 2 (B2) connects the core part with the connector part, and bolt 3 and bolt 4 (B3, B4) are two bolts connect the connector part to the lower part.

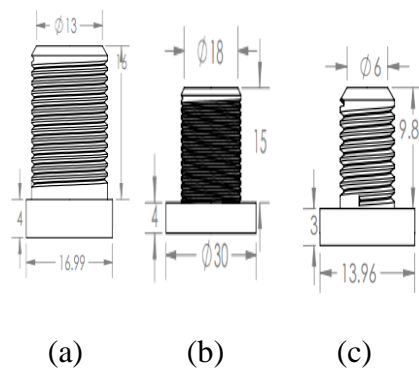

Fig 4.9 the front view of bolts. (a) Bolt 1(B1), (b) bolt 2 (B2), and (c) bolt 3 and bolt 4 (B3 and B4).

4.3 The analysis

The design model had been imported to ANSYS15.0 program as an assembly in (*.asm;*.sldasm) format. The contacts regions were eleven and all the types were bonded contact, Meshing had been generated for the whole design (Fig 4.10), relevance centre and span angle centre had been determined as fine, size of elements was the default elements numbers were 135146, and the nodes numbers were 231852.

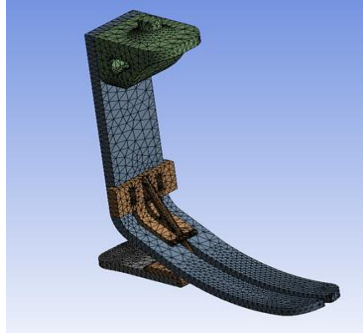

Fig 4.10 the meshed design.

The whole design parts had been analyzed firstly using two different materials aluminium alloy and stainless steel, for these materials can be locally available in the market, on other hands these materials get involved in lots of products manufacturing not only rehabilitation components. The properties of the materials were from ANSYS library, the materials failed to pass the test, then the design had been analysis using titanium alloy material for this material has properties of strength of weight ratio[10], the properties were from ANSYS library, the test also failed, then the properties of the three materials had been modified many times which had been taken from [34, 35], overall all the tries had been done using the same material in all parts failed to pass the test in all stages. Then the design had been analyzed using two materials titanium alloy which had been used in the connector, B2 and lower parts and stainless steel had been used in B1, B3, B4, the core and socket adaptor parts, the two materials titanium alloy and stainless steel materials passed the tests in all stages. Table 4.1 shows the materials properties had been used in the analysis, the same properties of stainless steel and titanium alloy had been used in the two materials.

Table 4.1 Materials properties.

Material properties	aluminium Alloy	Titanium Alloy	Stainless Steel
Density	2.77e-006 kg mm ⁻³	4.62 e-006 kg mm ⁻³	7.75e-006 kg mm ⁻³
Tensile yield strength	280MPa	930MPa	207MPa
Tensile ultimate strength	310MPa	1070MPa	586MPa
Young's Modulus	71000MPa	96000MPa	1.93e+005MPa
Shear Modulus	26692MPa	35294MPa	73664MPa

The foot in the lower part approximately represent the 1/3 of the foot length, this part was divided into two faces by default, a face split had been made to divide the foot in the core part is approximately represents the 2/3 of the foot length, and this step had been done to apply the force on faces (Fig 4.11).

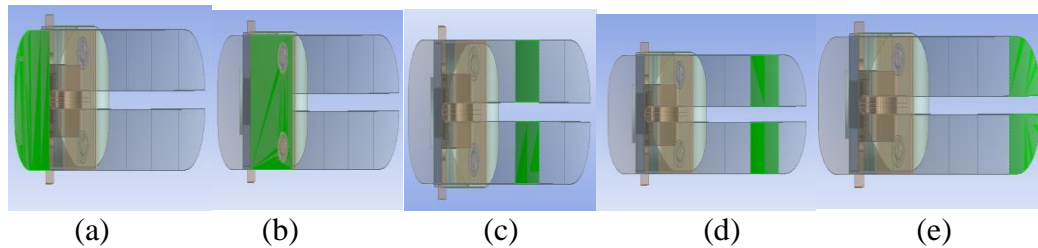
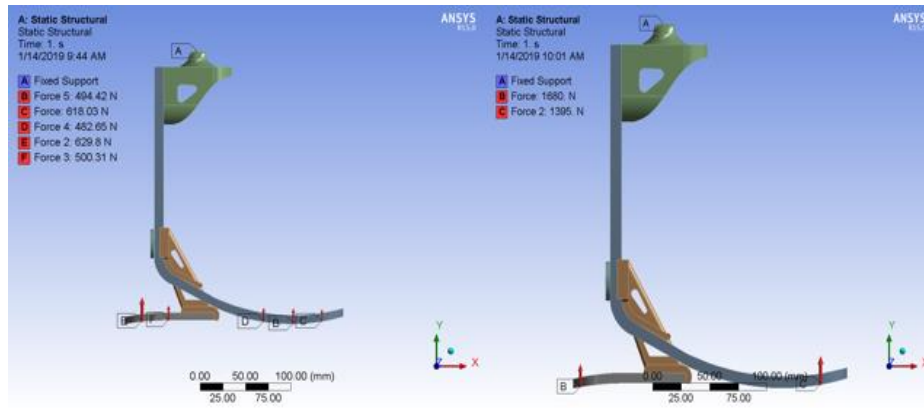

Fig 4.11 faces positions bottom view. (a) Initial contact, (b) loading response, (c) midstance, (d) terminal stance, and (e) toe-off stages.

Forces had been applied as component in y-direction and it is represented in the red vector, the value of the force is the value of the ground reaction force (GRF) in all stages in static position, for x and z component was zero value, the fixed supports had been applied on the top of the socket adaptor on all stages, the same position of the fixed support had been determined for ISO load but the values were different, and here the forces had been applied in initial contact and toe-off stages only. Fig 4.12 shows the Boundary conditions forces and constraints in both cases.



(a) (b)
 Fig 4.12 boundary conditions. (a) Stance phase stages, and (b) ISO test load.

4.4 Ground reaction force during gait cycle stages calculation

Tea et al. (2009) tested the force exerted by the human body on a force plate, this force is the summation of gravity acceleration times the segment masses. Fig 4.13 indicates the vertical ground reaction force in the left which is in dots lines and the right foot which is in connected line, where there are two peaks appears as the maximum values of vertical GRF in initial contact stage 107% of the body weight, and 105% in the toe-off stage, between these two peaks the vertical ground reaction force, decreases due to inertial force direction [36].

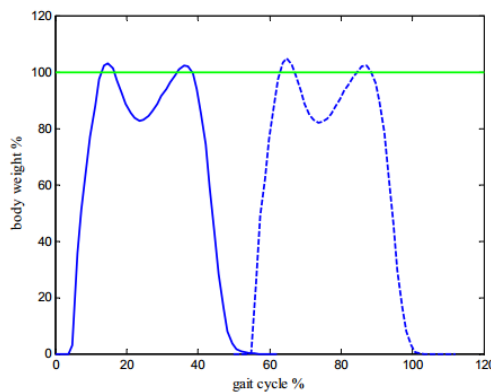

Fig 4.13 curve of vertical ground reaction force left and right legs [36].

To calculate the ground reaction force effects on our subject which we assume to be 60 kg of mass, walking at normal speed, the design is for the right foot.

The weight of the subject is calculated as in equation (4.1)

$$W = m \times a \tag{4.1}$$

Where W is the weight of the subject, m is the mass of the subject, a is the gravity acceleration.

$$W = 60 \times 9.81 = 588.6 \text{ N.}$$

At the end of the initial contact stage, the vertical ground reaction force (GRF v) equal 107% of body weight.

$$\text{GRF v} = (107/100) \times 588.6 = 629.802 \text{ N.}$$

From Fig 4.13 the value of vertical ground reaction force had been approximated in loading response stage and it is 85% of body weight.

$$\text{GRF v} = (85/100) \times 588.6 = 500.31 \text{ N.}$$

From Fig 4.13 the value of vertical ground reaction force had been approximated in midstance stage and it is 82% of body weight.

$$\text{GRF v} = (82/100) \times 588.6 = 482.652 \text{ N.}$$

From Fig 4.13 the value of vertical ground reaction force had been approximated in terminal stance stage and it is 84% of body weight.

$$\text{GRF v} = (84/100) \times 588.6 = 494.424.$$

The end of Toe-off stage the vertical ground reaction force (GRF v) equal 105% of body weight.

$$\text{GRF v} = (105/100) \times 588.6 = 618.03 \text{ N [36].}$$

4.5 ISO 10328 tests load

The load is specified according to ISO 10328 standard for a patient his mass is 60 kg (P3 category) which is equal to 1680 N at initial contact (condition I), and 1395 N at toe-off (condition II) [7, 45].

Chapter five

Results, and Discussion

5.1 Mechanical analysis background

5.1.1 Total Deformation

Also called shaped deformation, it is the summation of the square root of all squared shearing and squared stretching deformations [37].

5.1.2 Maximum principle elastic strain

It is the maximum correspondent value to maximum principal stress in the elastic region.

5.1.3 Maximum principal (normal) stress

When a force applied on a surface of a small volume of material normal and shear components resulted, maximum principal stress is the maximum normal component resulted, this stress is used in maximum stress theory which neglects the shear stress [38].

5.1.4 Equivalent (von-Mises) stress

One of the theories used to predict yielding in ductile material is von Mises theory, it assumes that yielding in these materials occurs if the equivalent stress is equal or bigger than specific stress, and it considers normal principal and shear stress as well [38]. Mathematically, the von Mises is calculated as in Equation (5.1).

$$\sqrt{\left[\frac{(\sigma_1 - \sigma_2)^2 + (\sigma_2 - \sigma_3)^2 + (\sigma_3 - \sigma_1)^2}{2} \right]} \geq S_y \quad (5.1) [39].$$

σ_1 Maximum principle stress, σ_2 Middle principle stress, σ_3 Minimum principle stress, S_y the yield strength of material.

5.1.5 Factor of safety

From an engineering perspective, and Equation (5.2). , the ratio of the strength of the material (S) and the allowable stress (σ) which is here von misses stress is called factor of safety (N), this ratio predicts the probability of failure in design parts. It is preferably to be not too small and not too big depending upon parts of the design and other considerations [40].

$$N = \frac{S}{\sigma} \quad (5.2) [40].$$

5.2 Results

Same faces of forces and values, and same boundary conditions had been applied on Aluminum alloy, stainless steel, titanium alloy materials, and lastly combination of two materials (Stainless steel + Titanium alloy), mechanical analysis using total deformation, maximum principle elastic strain, maximum principal stress, and equivalent stress in the five stages of stance phase initial contact, loading response, midstance, terminal stance, and toe-off had been done to these materials. And the results were as follows.

5.2.1 Initial contact stage results

5.2.1.1 Total deformation

Fig 5.1 shows the total deformations for all materials, the position of the maximum in all the materials was in the core part in the position of toes. Table 5.1 represents the maximum values of total deformation for all materials, where the biggest value is an aluminium alloy and the smallest one is stainless steel.

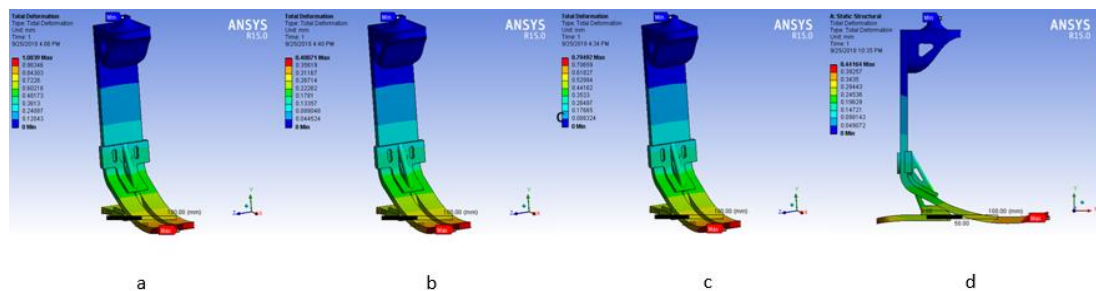

Fig 5.1 Total deformation in the initial contact stage for all materials. (a) Aluminium alloy, (b) Stainless steel, (c) Titanium alloy, and (d) (Stainless steel + Titanium alloy) materials.

Table 5.1 maximum values of Total deformation in the initial contact stage for all materials.

	Aluminium alloy	Stainless steel	Titanium alloy	(Stainless steel + Titanium alloy)
Max total deformation	1.0839 mm	0.40071 mm	0.79492 mm	0.44164 mm

5.2.1.2 Maximum Principal Elastic Strain

Fig 5.2 shows the maximum principal elastic strain for all materials, the position of the maximum in all the materials was in the connector part. Table 5.2 represents the maximum values of maximum principal elastic strain for all materials, where the biggest value is an aluminium alloy and the smallest one is stainless steel.

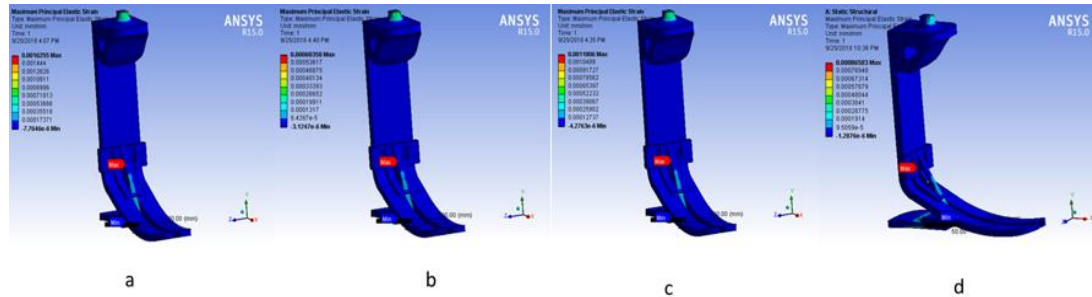

Fig 5.2 Maximum Principal Elastic Strain in the initial contact stage for all materials. (a) Aluminium alloy, (b) Stainless steel, (c) Titanium alloy, and (d) (Stainless steel + Titanium alloy) materials.

Table 5.2 maximum values of Maximum Principal Elastic Strain in the initial contact stage for all materials.

	Aluminium alloy	Stainless steel	Titanium alloy	(Stainless steel + Titanium alloy)
Max Principal Elastic Strain	0.0016255 mm/mm	0.00060358 mm/mm	0.0011806 mm/mm	0.00086583 mm/mm

5.2.1.3 Maximum Principal Stress

Fig 5.3 shows the maximum principal stress for all materials, in all the materials the position of the maximum was in the connector part. Table 5.3 represents the maximum values of maximum principal stress for all materials, where the biggest value is titanium alloy and the smallest one is (stainless steel + titanium alloy).

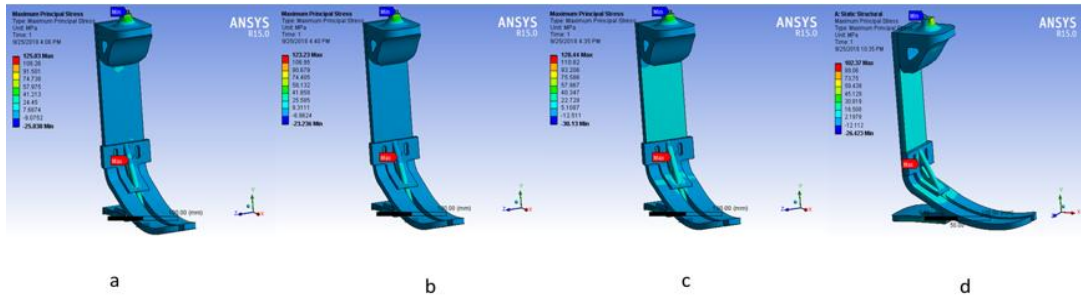

Fig 5.3 Maximum Principal Stress in initial contact stage for all materials. (a) Aluminium alloy, (b) Stainless steel, (c) Titanium alloy, and (d) (Stainless steel + Titanium alloy) materials.

Table 5.3 maximum values of Maximum Principal Stress in initial contact stage for all materials.

	Aluminium alloy	Stainless steel	Titanium alloy	(Stainless steel + Titanium alloy)
Max Principal Stress	125.03MPa	123.23MPa	128.44MPa	102.37MPa

5.2.1.4 Equivalent Stress

Fig 5.4 shows the equivalent stress for all materials, the position of the maximum in all the materials was in the connector part. Table 5.4 represents the maximum values of equivalent stress for all materials, where the biggest value is Stainless steel and the smallest one is (stainless steel + titanium alloy).

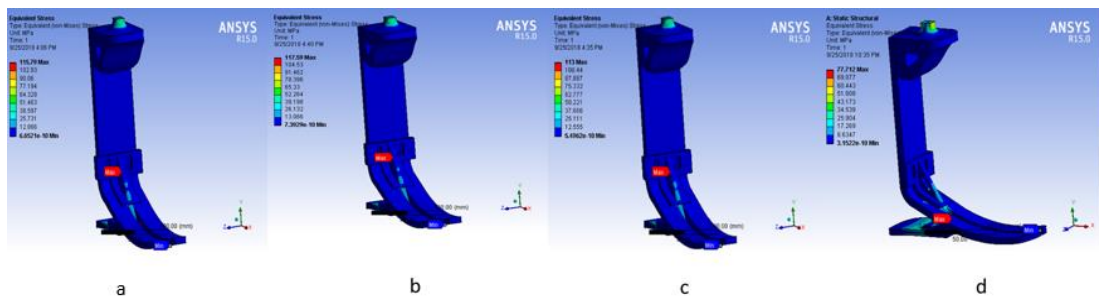

Fig 5.4 Equivalent Stress in initial contact stage for all materials. (a) Aluminium alloy, (b) Stainless steel, (c) Titanium alloy, and (d) (Stainless steel + Titanium alloy) materials.

Table 5.4 maximum values of Equivalent Stress in initial contact stage for all materials.

	Aluminium alloy	Stainless steel	Titanium alloy	(Stainless steel + Titanium alloy)
Max Equivalent Stress	115.79MPa	117.59MPa	113MPa	77.712MPa

5.2.2 Loading response stage results

5.2.2.1 Total deformation

Fig 5.5 shows the total deformations for all materials, the position of the maximum in all the materials was in the core part in the position of toes. Table 5.5 represents the maximum values of total deformation for all materials, where the biggest value is an aluminium alloy and the smallest one is stainless steel.

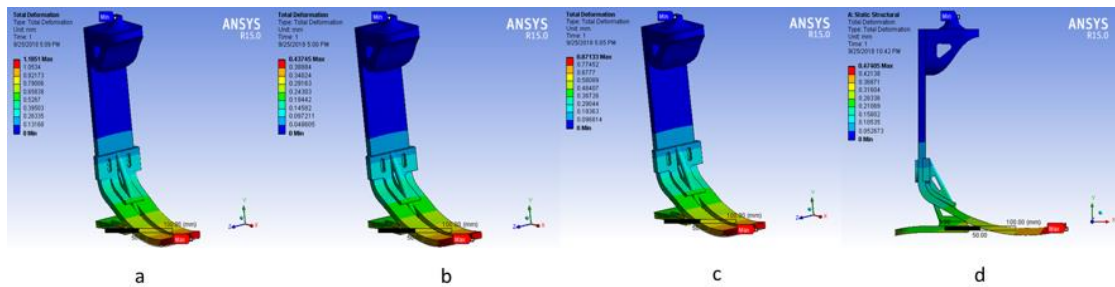

Fig 5.5 Total deformation in loading response stage for all materials. (a) Aluminium alloy, (b) Stainless steel, (c) Titanium alloy, and (d) (Stainless steel + Titanium alloy) materials.

Table 5.5 maximum values of Total deformation in loading response stage for all materials

	Aluminium alloy	Stainless steel	Titanium alloy	(Stainless steel + Titanium alloy)
Max Total deformation	1.1851 mm	0.43745 mm	0.87133 mm	0.47405 mm

5.2.2.3 Maximum Principal Elastic Strain

Fig 5.6 shows the maximum principal elastic strain for all materials, the position of the maximum in all the materials was in the connector part. Table 5.6 represents the

maximum values of maximum principal elastic strain for all materials, where the biggest value is an aluminium alloy and the smallest one is stainless steel.

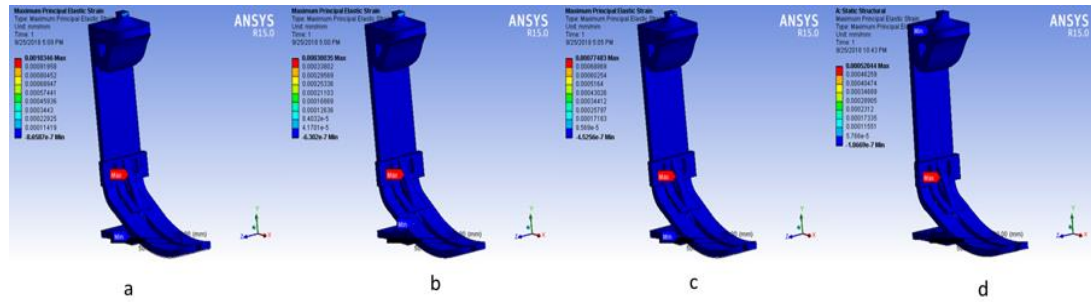

Fig 5.6 Maximum Principal Elastic Strain in loading response stage for all materials. (a) Aluminium alloy, (b) Stainless steel, (c) Titanium alloy, and (d) (Stainless steel + Titanium alloy) materials.

Table 5.6 maximum values of maximum Principal Stress in loading response stage for all materials

	Aluminium alloy	Stainless steel	Titanium alloy	(Stainless steel + Titanium alloy)
Max Principal Elastic Strain	0.0010346 mm/mm	0.00038035 mm/mm	0.00077483 mm/mm	0.00052044 mm/mm

5.2.2.4 Maximum Principal Stress

Fig 5.7 shows the maximum principal stress for all materials, the position of the maximum in all the materials was in the connector part. Table 5.7 represents the maximum values of maximum principal stress for all materials, where the biggest value is titanium alloy and the smallest one is (stainless steel + titanium alloy).

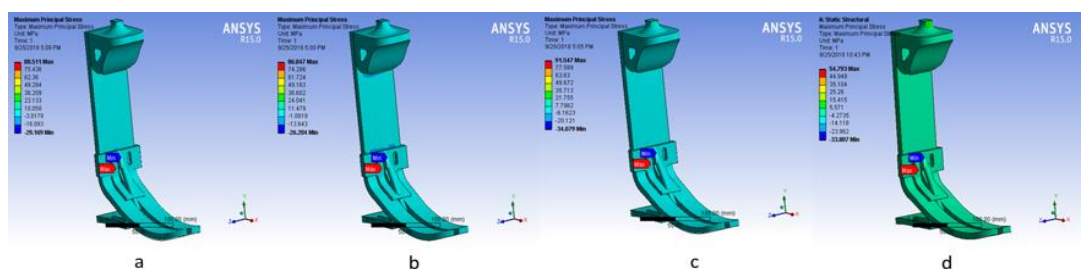

Fig 5.7 Maximum Principal Stress in loading response stage for all materials. (a) Aluminium alloy, (b) Stainless steel, (c) Titanium alloy, and (d) (Stainless steel + Titanium alloy) materials.

Table 5.7 maximum values of maximum Principal Stress in loading response stage for all materials

	Aluminium alloy	Stainless steel	Titanium alloy	(Stainless steel + Titanium alloy)
Max Principal Stress	88.511MPa	86.847MPa	91.547MPa	54.793MPa

5.2.2.5 Equivalent Stress

Fig 5.8 shows the equivalent stress for all materials, the position of the maximum in all the materials was in the connector part. Table 5.8 represents the maximum values of equivalent stress for all materials, where the biggest value is Stainless steel and the smallest one is (stainless steel + titanium alloy).

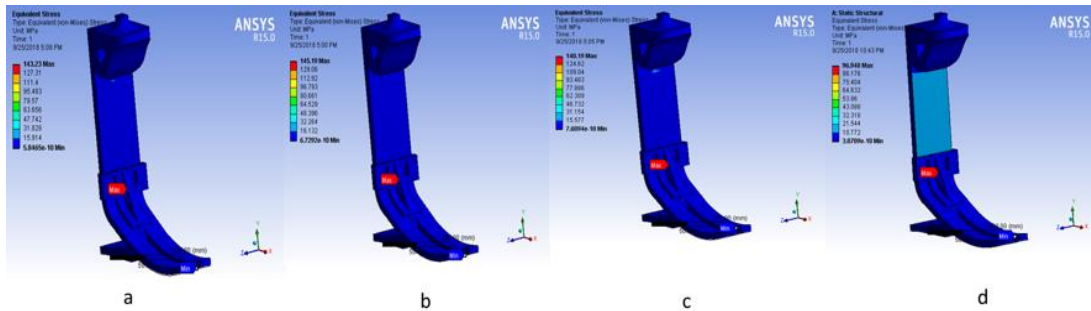

Fig 5.8 Equivalent Stress in loading response stage for all materials. (a) Aluminium alloy, (b) Stainless steel, (c) Titanium alloy, and (d) (Stainless steel + Titanium alloy) materials.

Table 5.8 maximum values of Equivalent Stress in loading response stage for all materials.

	Aluminium alloy	Stainless steel	Titanium alloy	(Stainless steel + Titanium alloy)
Max Equivalent Stress	143.23MPa	145.19MPa	140.19MPa	96.948MPa

5.2.3 Midstance stage results

5.2.3.1 Total deformation

Fig 5.9 shows the total deformations for all materials, the position of the maximum in all the materials was in the core part in the position of toes. Table 5.9 represents the

maximum values of total deformation for all materials, where the biggest value is an aluminium alloy and the smallest one is stainless steel.

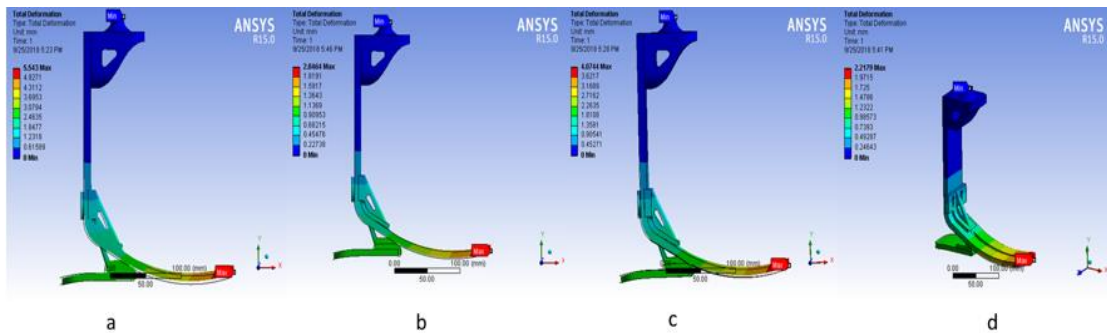

Fig 5.9 Total deformation in midstance stage for all materials. (a) Aluminium alloy, (b) Stainless steel, (c) Titanium alloy, and (d) (Stainless steel + Titanium alloy) materials.

Table 5.9 maximum values of Total deformation in midstance stage for all materials

	Aluminium alloy	Stainless steel	Titanium alloy	(Stainless steel + Titanium alloy)
Max Total deformation	5.543 mm	2.0464 mm	4.0744 mm	2.2179 mm

5.2.3.2 Maximum Principal Elastic Strain

Fig 5.10 shows the maximum principal elastic strain for all materials, the position of the maximum in all the materials was in the connector part. Table 5.10 represents the maximum values of maximum principal elastic strain for all materials, where the biggest value is an aluminium alloy and the smallest one is stainless steel.

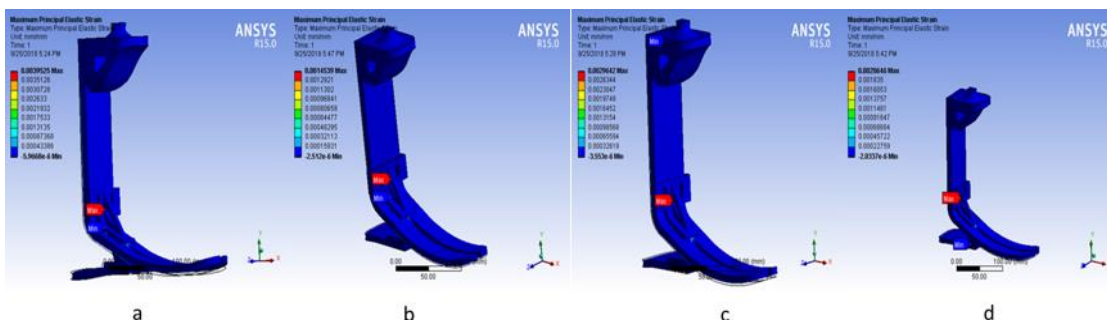

Fig 5.10 Maximum Principal Elastic Strain in midstance stage for all materials. (a) Aluminium alloy, (b) Stainless steel, (c) Titanium alloy, and (d) (Stainless steel + Titanium alloy) Maximum materials.

Table 5.10 maximum values of Maximum Principal Elastic Strain in midstance stage for all materials

	Aluminium alloy	Stainless steel	Titanium alloy	(Stainless steel + Titanium alloy)
Max Principal Elastic Strain	.0039525 mm/mm	.0014539 mm/mm	.0029642 mm/mm	0.0020646 mm/mm

5.2.3.3 Maximum Principal Stress

Fig 5.11 shows the maximum principal stress for all materials, the position of the maximum in all the materials was in the connector part. Table 5.11 represents the maximum values of maximum principal stress for all materials, where the biggest value is titanium alloy and the smallest one is (stainless steel + titanium alloy).

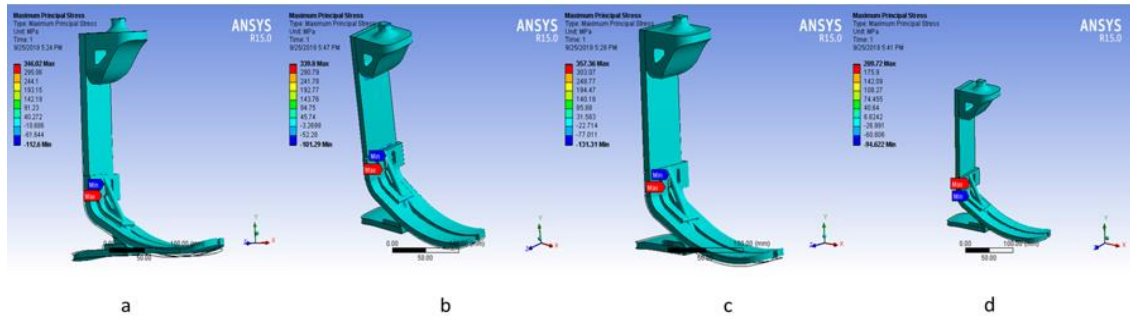

Fig 5.11 Maximum Principal Stress in Midstance stage for all materials. (a) Aluminium alloy, (b) Stainless steel, (c) Titanium alloy, and (d) (Stainless steel + Titanium alloy) materials.

Table 5.11 maximum values of maximum Principal Stress in Midstance stage for all materials

	Aluminium alloy	Stainless steel	Titanium alloy	(Stainless steel + Titanium alloy)
Max Principal Stress	346.02MPa	339.8MPa	357.36MPa	209.72MPa

5.2.3.4 Equivalent Stress

Fig 5.12 shows the equivalent stress for all materials, the position of the maximum in all the materials was in the connector part. Table 5.12 represents the maximum values of equivalent stress for all materials, where the biggest value is Stainless steel and the smallest one is (stainless steel + titanium alloy).

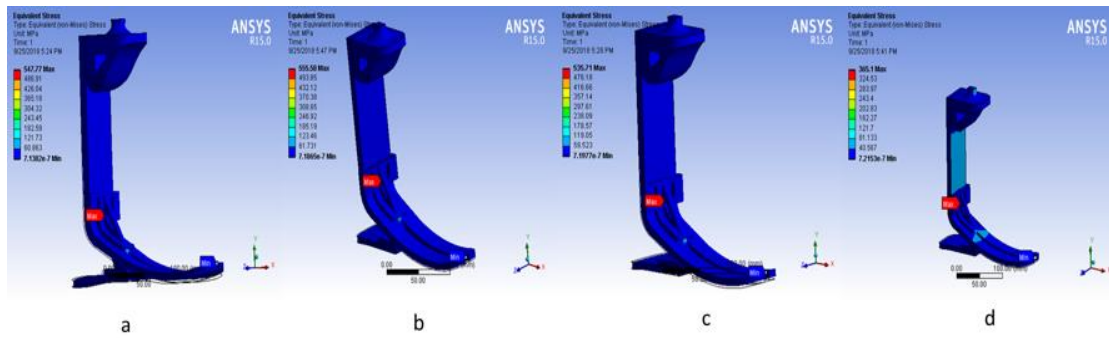

Fig 5.12 Equivalent Stress in midstance stage for all materials. (a) Aluminium alloy, (b) Stainless steel, (c) Titanium alloy, and (d) (Stainless steel + Titanium alloy) materials.

Table 5.12 maximum values of Equivalent Stress in midstance stage for all materials

	Aluminium alloy	Stainless steel	Titanium alloy	(Stainless steel + Titanium alloy)
Max Equivalent Stress	547.77MPa	555.58MPa	535.71MPa	365.1MPa

5.2.4 Terminal Stance stage results

5.2.4.1 Total deformation

Fig 5.13 shows the total deformations for all materials, the position of the maximum in all the materials was in the core part in the position of toes. Table 5.13 represents the maximum values of total deformation for all materials, where the biggest value is an aluminium alloy and the smallest one is stainless steel.

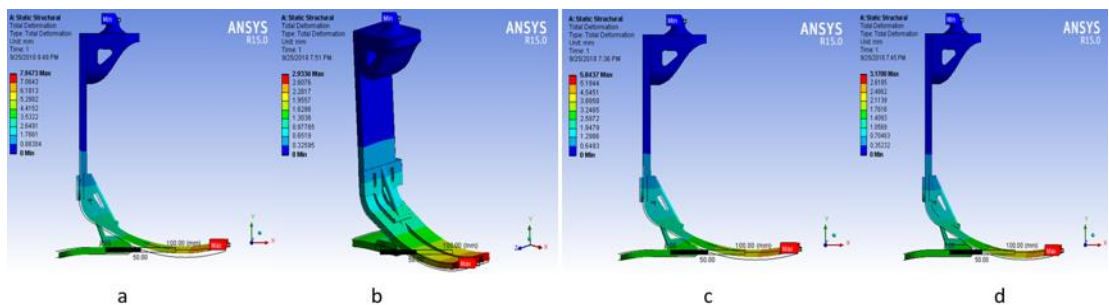

Fig 5.13 Total deformation in terminal Stance stage for all materials. (a) Aluminium alloy, (b) Stainless steel, (c) Titanium alloy, and (d) (Stainless steel + Titanium alloy) materials.

Table 5.13 maximum values of Total deformation in terminal Stance stage for all materials.

	Aluminium alloy	Stainless steel	Titanium alloy	(Stainless steel + Titanium alloy)
Max Total deformation	7.9473 mm	2.9336 mm	5.8437 mm	3.1708 mm

5.2.4.2 Maximum Principal Elastic Strain

Fig 5.14 shows the maximum principal elastic strain for all materials, the position of the maximum in all the materials was in the connector part. Table 5.14 represents the maximum values of maximum principal elastic strain for all materials, where the biggest value is an aluminium alloy and the smallest one is stainless steel.

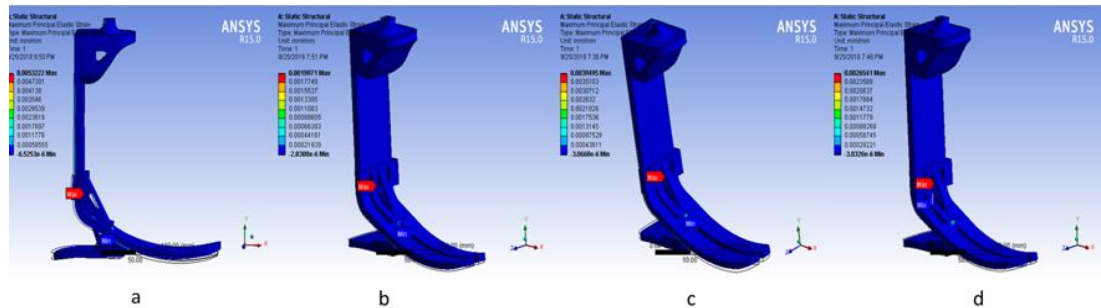

Fig 5.14 Maximum Principal Elastic Strain in terminal Stance stage for all materials. (a) Aluminium alloy, (b) Stainless steel, (c) Titanium alloy, and (d) (Stainless steel + Titanium alloy) materials.

Table 5.14 maximum values of Maximum Principal Elastic Strain in terminal Stance stage for all materials.

	Aluminum alloy	Stainless steel	Titanium alloy	(Stainless steel + Titanium alloy)
Max Principal Elastic Strain	0.0053222 mm/mm	0.0019971 mm/mm	0.0039495 mm/mm	0.0026541 mm/mm

5.2.4.3 Maximum Principal Stress

Fig 5.15 shows the maximum principal stress for all materials, the position of the maximum in all the materials was in the connector part. Table 5.15 represents the

maximum values of maximum principal stress for all materials, where the biggest value is titanium alloy and the smallest one is (stainless steel + titanium alloy).

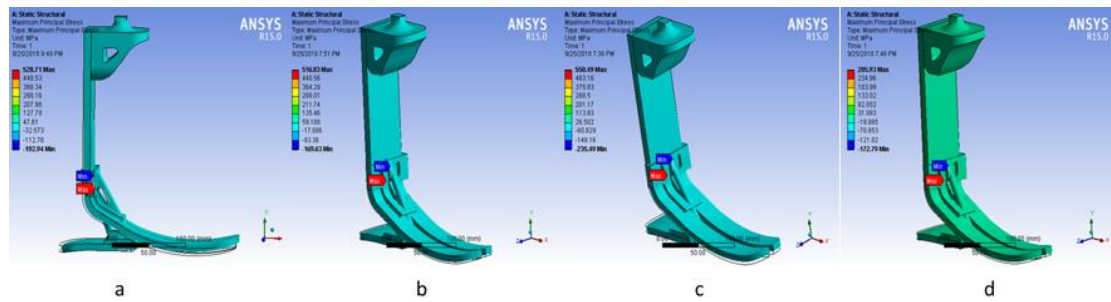

Fig 5.15 Maximum Principal Stress in terminal Stance stage for all materials. (a) Aluminium alloy, (b) Stainless steel, (c) Titanium alloy, and (d) (Stainless steel + Titanium alloy) materials.

Table 5.15 maximum values of maximum Principal Stress in terminal Stance stage for all materials

	Aluminium alloy	Stainless steel	Titanium alloy	(Stainless steel + Titanium alloy)
Max Principal Stress	528.71MPa	516.83MPa	550.49MPa	285.93MPa

5.2.4.4 Equivalent Stress

Fig 5.16 shows the equivalent stress for all materials, the position of the maximum in all the materials was in the connector part. Table 5.16 represents the maximum values of equivalent stress for all materials, where the biggest value is Stainless steel and the smallest one is (stainless steel + titanium alloy).

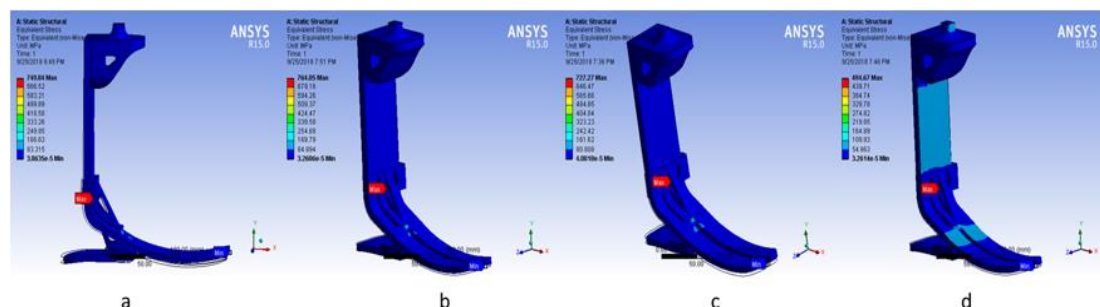

Fig 5.16 Equivalent Stress in terminal Stance stage for all materials. (a) Aluminium alloy, (b) Stainless steel, (c) Titanium alloy, and (d) (Stainless steel + Titanium alloy) materials.

Table 5.16 maximum values of Equivalent Stress in terminal Stance stage for all materials

	Aluminium alloy	Stainless steel	Titanium alloy	(Stainless steel + Titanium alloy)
Max Equivalent Stress	749.84MPa	764.05MPa	727.27MPa	494.67MPa

5.2.5 Toe- off stage

5.2.5.1 Total deformation

Fig 5.17 shows the total deformations for all materials, the position of the maximum in all the materials was in the core part in the position of toes. Table 5.17 represents the maximum values of total deformation for all materials, where the biggest value is an aluminium alloy and the smallest one is stainless steel.

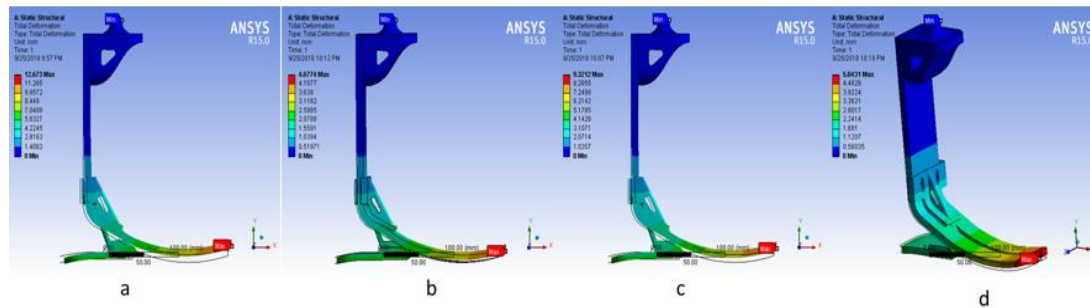

Fig 5. 17 Total deformations in the toe-off stage for all materials. (a) Aluminium alloy, (b) Stainless steel, (c) Titanium alloy, and (d) (Stainless steel + Titanium alloy) materials.

Table 5. 17 maximum values of Total deformation in the toe-off stage for all materials

	Aluminium alloy	Stainless steel	Titanium alloy	(Stainless steel + Titanium alloy)
Max Total deformation	12.673 mm	4.6774 mm	9.3212 mm	5.0431 mm

5.2.5.2 Maximum Principal Elastic Strain

Fig 5.18 shows the maximum principal elastic strain for all materials, the position of the maximum in all the materials was in the connector part. Table 5.18 represents the

maximum values of maximum principal elastic strain for all materials, where the biggest value is an aluminium alloy and the smallest one is stainless steel.

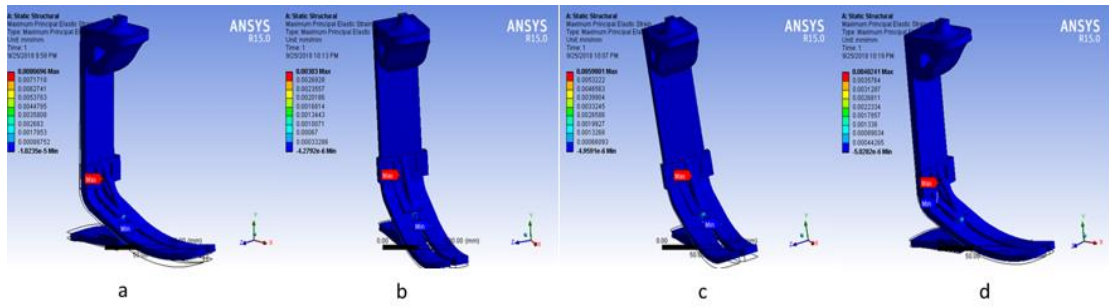

Fig 5.18 Maximum Principal Elastic Strain in the toe-off stage for all materials. (a) Aluminium alloy, (b) Stainless steel, (c) Titanium alloy, and (d) (Stainless steel + Titanium alloy) materials.

Table 5.18 maximum values of Maximum Principal Elastic Strain in the toe-off stage for all materials

	Aluminium alloy	Stainless steel	Titanium alloy	(Stainless steel + Titanium alloy)
Max Principal Elastic Strain	0.0080696 mm/mm	0.00303 mm/mm	0.0059881 mm/mm	0.0040241 mm/mm

5.2.5.3 Maximum Principal Stress

Fig 5.19 shows the maximum principal stress for all materials, the position of the maximum in all the materials was in the connector part. Table 5.19 represents the maximum values of maximum principal stress for all materials, where the biggest value is titanium alloy and the smallest one is (stainless steel + titanium alloy).

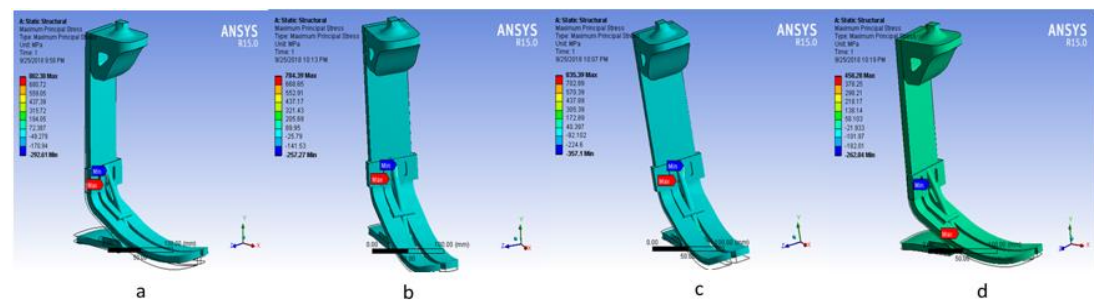

Fig 5.19 Maximum Principal Stress in the toe-off stage for all materials. (a) Aluminium alloy, (b) Stainless steel, (c) Titanium alloy, and (d) (Stainless steel + Titanium alloy) materials.

Table 5.19 maximum values of maximum Principal Stress in the toe-off stage for all materials

	Aluminium alloy	Stainless steel	Titanium alloy	(Stainless steel + Titanium alloy)
Max Principal Stress	802.38Ma	784.39MPa	835.39MPa	458.28MPa

5.2.5.4 Equivalent Stress

Fig 5.20 shows the equivalent stress for all materials, the position of the maximum in all the materials was in the connector part. Table 5.20 represents the maximum values of equivalent stress for all materials, where the biggest value is Stainless steel and the smallest one is (stainless steel + titanium alloy).

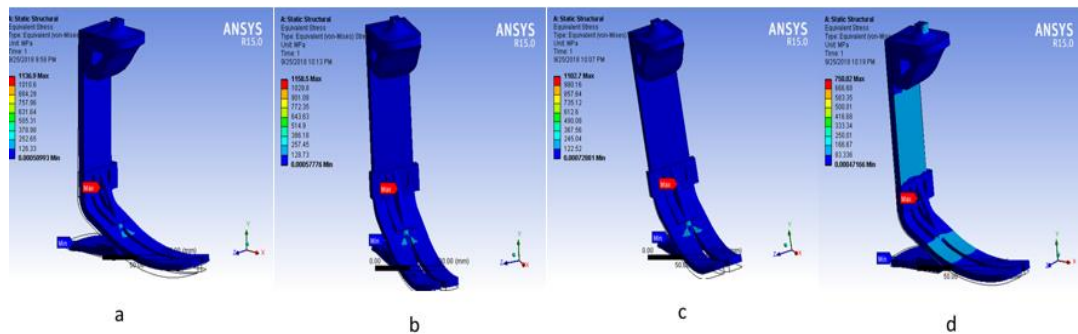

Fig 5.20 Equivalent Stress in the toe-off stage for all materials. (a) Aluminium alloy, (b) Stainless steel, (c) Titanium alloy, and (d) (Stainless steel + Titanium alloy) materials.

Table 5.20 maximum values of Equivalent Stress in the toe-off stage for all materials

	Aluminium alloy	Stainless steel	Titanium alloy	(Stainless steel + Titanium alloy)
Max Equivalent Stress	1136.9MPa	1158.5MPa	1102.7MPa	750.02MPa

5.2.6 Safety factor

The safety factor had been applied for the two materials (Stainless steel + Titanium alloy) in the five stages of stance phase initial contact, loading response, midstance, terminal stance, and toe-off. Fig 5.21 show the results of the safety factor in all stage for (stainless steel + titanium alloy) materials. The maximum position was in the

middle of the core part this place represents the place of the minimum value for the whole design, Table 5.21 lists the minimum values of safety factor in all stages, where the maximum value is in loading response stage and the minimum value in the toe-off stage.

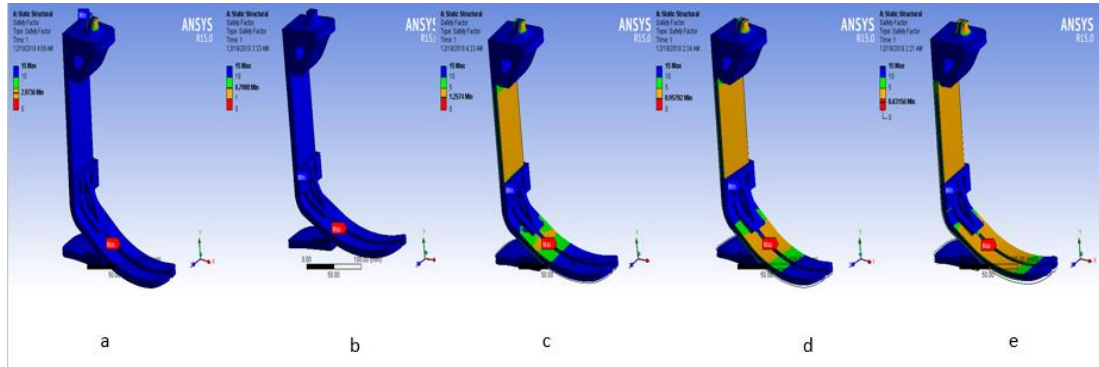

Fig 5.21 safety factor in all stage for (stainless steel + titanium alloy). (a) Initial contact, (b) loading response, (c) midstance, (d) terminal stance, and (e) toe-off stages.

Table 5.21 minimum values of safety factor in all stage for (stainless steel + titanium alloy).

	Initial contact	Loading response	Midstance	Terminal stance	Toe-off
Safety factor (Min)	2.9736	4.7988	1.2574	0.95702	0.63156

5.2.7 ISO test load results

Forces values had been determined from ISO standard for lower limbs prosthetics[7], and then had been applied on two materials (Stainless steel + Titanium alloy), mechanical analysis using total deformation, maximum principal stress, equivalent stress, and factor of safety in the initial contact, and toe-off stages only had been done to the two materials (Stainless steel + Titanium alloy). And the results were as follows:

5.2.7.1 Initial contact results

Fig 5.22 shows the maximum and the minimum values for (Stainless steel+ titanium) materials in the initial contact stage, the maximum total deformation position is on the core part, the connector part is the position of the maximum the equivalent stress and the maximum Principal stress as well, the factor of safety maximum position

represents the minimum value of factor of safety for the whole design and here is in the middle of the core part. Table 5.22 lists the maximum values for total deformation, equivalent stress, maximum principal stress, and the minimum value of factor of safety.

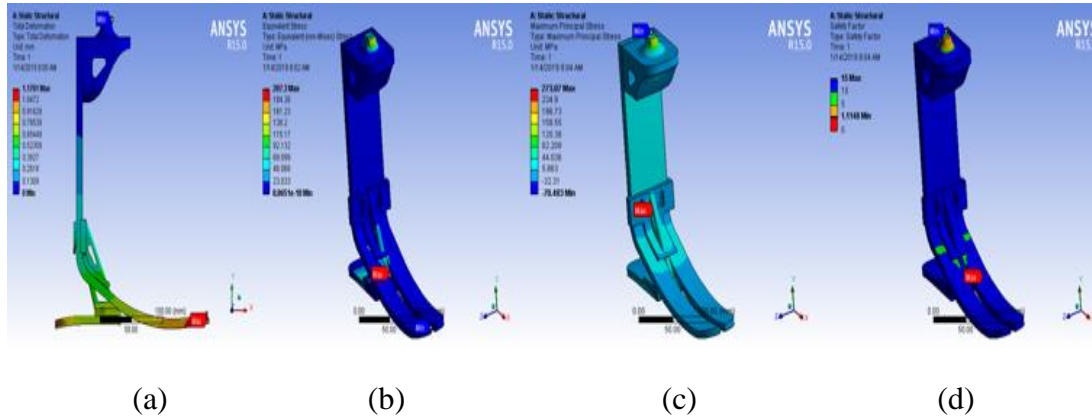

Fig 5.22 ISO load test in the initial contact stage for (Stainless steel+ titanium). (a) Total deformation, (b) equivalent stress, (c) maximum Principal stress, and (d) factor of safety.

Table 5.22 the maximum and minimum values of ISO load test in the initial contact stage for (Stainless steel+ titanium) materials.

	Total deformation (max)	Equivalent stress (max)	Maximum principal stress (max)	Factor of safety (min)
(Stainless steel + titanium alloy)	1.1781mm	207.3MPa	273.07MPa	1.1148

5.2.7.2 Toe-off results

Fig 5.23 shows the maximum and minimum values for (Stainless steel+ titanium) materials in the toe-off stage, the maximum total deformation position is on the core part, the equivalent stress and maximum principal stress maximum positions are in the connector part, the factor of safety maximum position represents the minimum value of factor of safety for the whole design and here is in the middle of the core part. Table 5.23 lists the maximum values for total deformation, equivalent stress, maximum principal stress, and the minimum value of factor of safety.

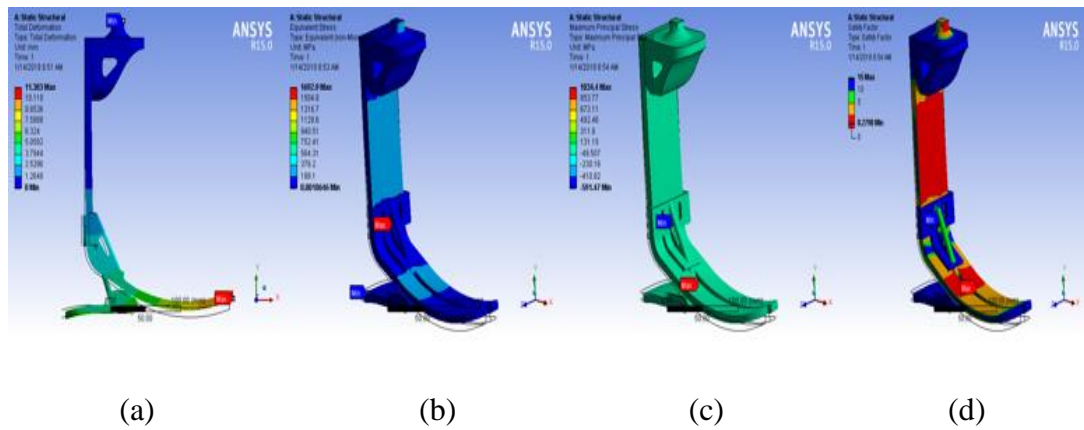

Fig 5.23 ISO load tests in the toe-off stage for (Stainless steel+ titanium). (a) Total deformation, (b) equivalent stress, (c) maximum Principal stress, and (d) factor of safety.

Table 5.23 the maximum and minimum values of ISO load test in the toe-off stage for (Stainless steel+ titanium) materials.

	Total deformation (max)	Equivalent stress (max)	Maximum principal stress (max)	Factor of safety (min)
(Stainless steel + titanium alloy)	11.38mm	1692.9MPa	1034.4MPa	0.2798

5.3 Discussion

The results showed that aluminium alloy had the biggest total deformation values [5], and the biggest maximum principal elastic strain values [41] between all materials in all stages. This due to the property of being malleable (elastic) [6]. Table 4.1 shows aluminium alloy young's modulus is bigger compared to stainless steel and is relatively younger than titanium alloy yet its density is less than titanium alloy. Between all materials, in all stages, Stainless steel had the smallest total deformation values and the smallest maximum principal elastic strain values. And the biggest the maximum Equivalent Stress [5], this because stainless steel is tough material [8], Table 4.1 shows stainless steel has the biggest shear modulus between other materials.

Titanium alloy had the biggest Maximum Principal Stress values between all materials in all stages. This due to the property of high strength [9]. Table 4.1 shows Titanium alloy has the biggest tensile yield strength between other materials.

The two materials (Stainless steel and Titanium alloy) had the smallest maximum principal stress values, and the smallest maximum equivalent stress values in all stages, which are less than tensile yield strength of titanium alloy (Table 4.1), this means it is the only material passed all the tests of maximum equivalent stress in all stages.

Depending on the results of the maximum equivalent stress values only is not enough, the program calculates the values for the two materials and gives the overall maximum value, that is why the safety factor results is needed to assure the equivalent stress is satisfied for both materials, the results showed that in the initial contact, loading response, midstance stages the safety factor is bigger than 1, and in the terminal stance and toe-off stages is less than 1, this means in the two last stages the design withstands less load than the determined allowable stress [40].

According to the load specified from ISO test result showed that in the initial contact stage the total deformation is small, the equivalent stress and maximum principal stress are less than the yield strength of the materials, and the factor of safety is bigger than 1, this means in the initial contact stage the design can withstand the load applied on it [46].

As for, toe-off stage the total deformation is big, the equivalent stress and maximum principal stress are bigger than the yield strength of the materials, and the factor of safety is less than 1, this means in the toe-off stage the design cannot withstand the applied load [46].

5.3.1 The cost calculation

Titanium alloy parts mass is equal to 0.44019 kg, price in dollar 1 kg equal (15 -38) US\$.

Stainless steel mass is equal to 2.9003054 kg.

Price in dollar 2 Ton equal (1450.00 – 2150.00) US\$.

While 2.9003054 kg equal to .002900305 ton

Then 2.9003054 kg price is (2 - 4) US\$.

The total design mass is equal to 3.3405044, an average is 29 US\$ without manufacturing cost [42].

Chapter six

Conclusion, and Recommendations

6.1 The design objectives

As matter of fact, rehabilitation manufacturing in Sudan faces lots of problems, thirteen governmental rehabilitation centres depends upon one technology which is ICRC technology, this means if ICRC stop working in Sudan the manufacturing of prosthesis and orthotics will stop in these centres, and people will go to the private centres, which import the products from outside Sudan by ordering them, this is good and satisfied with the needs of patients but the price is costly and not all patients can afford them. EVA soft socket, the colour of the hard sockets, and the foot of ICRC technology are unsuitable for all patients, the SACH foot is always torn out sometimes after three months due to bad storage of materials even before NAPO received the feet. The number of service providers in manufacturing prosthesis is not enough to cover all amputee numbers which increases every year, this leads to many problems one of them if the worker does not work more than his capacity, this will make patients wait for a long time or decide to live without prosthesis being bored of waiting, secondly if the worker makes a lot of prostheses this will reduce the quality of prosthesis and patients will come back either for amendments or recasting, both cases means more load.

From these points making design for transtibial amputees which can be executed and manufactured locally in Sudan, a design can be manufactured using available tools, less in its price than private centres, takes less time and easy in assembling than the existing work takes, reduces the problem of not having enough workers had been put into consideration when designing.

6.2 Merits and demerits of the design

After executing the design, there are some advantages and disadvantages determines the ability of the design to be in the local market.

The merits of the design are it is easy to design using any sketch computer program, it is composed of fours parts only connected via the bolts, it is inexpensive compared to the existing designs in Sudan, it does not need lots of tools to assemble it, the parts are

easy to be repaired and replaced, and the design can be executed by CNC or 3D printer machines.

The demerits of the design are stainless steel which is used in some parts is considered as heavier than other materials used in prosthetic devices, titanium alloy material which is used in others parts is not available locally but it can be imported, the core part represents the leg and foot this means if any part of it damaged we should change the whole part, the design is for specific patient who their leg length is 24 cm.

6.3 Comparison between the design and other designs in Sudan

We will make a comparison between our designs with the existing designs in the Sudanese market.

6.3.1 The design and NAPO design Comparison

The design price is approximately 29 US\$ without the cost of the manufacturing. The foot and the concave cylinders (P.P CAS as they called it in NAPO) is about 40 US\$, then we can say the price is approximately the same.

The ICRC foot is made from polyurethane foam, and it represents the weakest part in their design, as for ours the keel here is from the same material of leg which is stainless steel this makes it can withstand more than ICRC foot.

6.3.2 The design and endoflex design Comparison

The shank and socket in the endoflex design is one part, which means the person who takes the measurements should be very qualified to not make any mistake in manufacturing which might lead to incorrect alignments and this means consuming a lot of material due to recasting, after some time of wearing the prosthesis the socket itself needs to be changed because the stump shape may change this problem suffer from it especially the new wearer, as for our design does not need a lot of care to adjust alignment like endoflex design needs.

6.3.3 The design and private centres design Comparison

The private centers even though have a unique advantage which provides high-quality prosthetic devices but the transtibial prosthetic in these centres cost between 10000 and 20000 SDG depending upon resin or polypropylene sockets which are considered as costly, that is why persons who go to these centres should be able to buy them, while our design price is cheap compared to their prices.

6.4 Conclusion

Components of the prosthesis in Sudan are brought from outside country, a design of prosthetic foot made from materials can be locally available is an additional choice for the transtibial amputee. Based on the result and discussion we conclude that, the design showed that using one material in all the parts is not effective because some parts need elasticity with high yield strength material while others not, the two material (stainless steel + titanium alloy) is the best choice between the other materials and this foot is suitable for the transtibial amputees who their mass is below 60 kg and their foot length is 24 cm, this size is for adults but it is near to children sizes.

6.5 Recommendations

Here are some recommendations to be put in mind and consideration to continue from where this thesis stopped, and to enhance the results.

Stainless steel is material has good properties makes it involved in many areas separating the core part into two parts and putting elastic material may enhance the foot and reduces the mass, further analysis to determine the best person who can use this prosthetic foot can be made or changing the geometry in the part where the design shows the safety factor less than 1, the load had been applied in y-direction only analyzing the design by putting the other components into consideration makes the analysis mimics natural foot more. Titanium alloy has a high strength to weight ratio increasing the thickness of the connector part and using aluminium with high properties to replace titanium alloy will reduce the cost, this design needs further works to satisfy the ISO standards so searching for the properties materials available in the Sudanese market will make the possibility of manufacturing.

6.6 Future work

In the future there are some steps needs to be done which will make the design manufactured and wore by the transtibial amputees.

Amend the design and analyze it once again, the connector part plays a major role in this design it connects between two important parts which are the core, and the lower parts this makes it suffer from a big load, and the results proved this we found the maximum equivalent stress value was in this part, if in the future this amendment is made it will lead to better results, the design had been amended many times specially this part to fulfill better results yet it is still the weakest part in the design, the problem

is that this part depends upon the position of all other parts to have the correct alignment this part should be in a specific place.

Analyze the design using others materials, the analysis was based on the materials which can be available locally in the market or even can be imported easily, a material which enters in manufacturing lots of products, not only prosthetics that is why the design had been analyzed with these materials, there are lots of other materials can be used in this design, this will expand the choices and then specifying the best material from all, focusing had been given to these materials only to not enlarge the work.

Design cosmetic shell for the foot and analyze it, cosmetic shell of the prosthetic foot gives good, nice, and natural appearance to the prosthetic foot, patient feels comfortable when he wears a foot in the shoes or look at it especially if the shell has the same colour as the skin, in the future we expect if this shell is added the results will be better especially if the shell is functional and made from light material, the second thing is the shell will make the recent foot as keel and this means the foot will expand to all foot sizes not only one size. This step had not been made because the cosmetic shell is considered a project by itself.

Use CNC machine to manufacture the design, computer numeric controlled (CNC) is subtractive technique works on a block of material, it needs a 3D model which created using computer-aided manufacturing (CAM) program, the machine works needs a design in G-Code format [43], the machine then moves in 3 directions after giving it the orders by the operator to complete the design using specific tools, these tools are different according to the design needs. Using a CNC machine to manufacture the design will save time more than using traditional ways. The financial issue had forbidden from reaching this step [44].

Analyzing the design by properties of material that can be found in shape of powder, indeed, 3D printing, is an additive technique this means parts being created layer-by-layer using source of energy, the material which is used by 3D printers are different, this design needs metal powders material using direct metal laser sintering (DMLS) 3D printer. The merits of this technique do not need a qualified operator, it creates complex geometry easily, and no need for many tools for manufacturing [43]. This step will make the design ready to be printed if this machine is available in the market. This machine is not in the market for the time being it might be in the future.

Connect the socket adaptor to a light socket, the step before wearing the patient to the design is to make a specific socket for specific patient, and the socket material can

be white polypropylene because it is light and easy to be found, a qualified person take the cast and not any person, in the future doing this step will make the design accomplish the purpose is made for it, this step had not been done because the design is only software, and the socket should be worn after a short time of taking the cast.

Fit the design to below knee amputee person, to fit the design to a patient this need many things firstly doing lots of analysis, secondly it is not ethical and legal to try design on a real patient unless you consult a specialized body in such issues, also you should have the approval from the destination responsible for such projects, the last thing to find a patient who has the same assumption of your design like weight, and shoes length and lastly being fit to try the design is not that easy.

References

- [1] Smith, D., 2003. Transtibial Amputations: Successes and Challenges. In *Motion*, 13(4), pp.57-63.
- [2] Powelson, T. and Yang, J.J., 2011, January. Prosthetics for Transtibial Amputees: A Literature Survey. In *ASME 2011 International Design Engineering Technical Conferences and Computers and Information in Engineering Conference* (pp. 753-764). American Society of Mechanical Engineers.
- [3] Bettess, P., 1977. Infinite elements. *International Journal for numerical methods in engineering*, 11(1), pp.53-64.
- [4] Pawar, P., Ballav, R. and Kumar, A., 2016. Finite Element Method Broach Tool Drilling Analysis Using Explicit Dynamics Ansys. *International Journal of Modern Manufacturing Technologies*, 8(2), pp.54-60.
- [5] Jabbar, A.A., Rai, A.K., REEDY, P.R. and Dakhil, M.H., 2014. Design and analysis of gas turbine rotor blade using finite element method. *International Journal of Mechanical and Production Engineering Research and Development*, 4(1), pp.73-94.
- [6] Krishna, S. and Ramesh, C.M., 2015. A Comparative Study of Aluminium Alloy and Titanium Alloy, *International Journal on Recent Technologies in Mechanical and Electrical Engineering (IJRMEE)* ISSN: 2349-7947, Volume 2, Issue 8, Available @ (<http://www.ijrmee.org>).
- [7] Yousif, A.E. and Sadiq, A.A., 2012. The Design, Development and Construction of An Adjustable Lower Extremity. *Journal of Engineering, IOSR Journal of Engineering (IOSRJEN)*, e-ISSN: 2250-3021, p-ISSN: 2278-8719, Volume 2, Issue 10, PP 30-42, available at (www.iosrjen.org).
- [8] Baddoo, N.R., 2008. Stainless steel in construction: A review of research, applications, challenges and opportunities. *Journal of Constructional Steel Research*, 64(11), pp.1199-1206.
- [9] Dong, S.L., Xin, Y.C., Lu, G., Yang, D.Z., He, S.Y. and Han, E.H., 2007. Tensile Properties and Deformation-Fracture Behavior of Ti-6Al-4V Alloy at Cryogenic Temperature. In *Materials Science Forum* (Vol. 561, pp. 207-210). Trans Tech Publications.
- [10] Krishnaraj, V., Samsudeensadham, S., Sindhumathi, R. and Kuppan, P., 2014. A study on high speed end milling of titanium alloy. *Procedia Engineering*, 97, pp.251-257.

- [11] Farahani, M.D., Moosavian, S.A.A. and Zarafshan, P., 2014, October. Conceptual design of a lower limb motion assist robot with bodyweight support. In *Robotics and Mechatronics (ICRoM), 2014 Second RSI/ISM International Conference on* (pp. 059-064). IEEE.
- [12] Lynn S. Lippert, MS, PT, 2011, *Clinical Kinesiology and Anatomy*, 5th edition, ISBN 0803623631, 9780803623637.
- [13] Michael W. Whittle, 2007, *GAIT ANALYSIS AN INTRODUCTION*, 4th edition, ISBN 9780750688833, 0750688831.
- [14] Lannon, N., 2003. Trans-tibial alignment: normal bench alignment. *ISPO Ortholetter*, 12, pp.12-3.
- [15] Zahedi, M.S., Spence, W.D., Solomonidis, S.E. and Paul, J.P., 1986. Alignment of lower limb prostheses. *J Rehabil Res Dev*, 23, pp.2-19.
- [16] Strait, E., 2006. Prosthetics in developing countries. *Prosthetic Resident*, pp.1-40.
- [17] McNaughton, D. (2018). Analysis, Testing, and Design of a Low-Cost Prosthetic Foot (University of Arkansas) | RESNA Student Design Competition. [Online] Sites.psu.edu. Available at: <https://sites.psu.edu/resnasdc/2012/06/13/analysis-testing-and-design-of-a-low-cost-prosthetic-foot-university-of-arkansas> [Accessed 2 Sep. 2018].
- [18] Yousif, A.E. and Sadiq, A.A., 2012. The Design, Development and Construction of an Adjustable Lower Extremity. *Journal of Engineering, IOSR Journal of Engineering (IOSRJEN)*, e-ISSN: 2250-3021, p-ISSN: 2278-8719, Volume 2, Issue 10 (October 2012), PP 30-42, available at (www.iosrjen.org).
- [19] Mangera, T.A.A.H.I.R.A.H., Govender, G.O.N.A.S.A.G.R.E.N. and Conning, M.A.R.I.E.T.T.E., 2015, July. Light Metals for the Functional Requirements of Developing World Lower Extremity Paediatric Prosthetics: A Review of Current Material & Technology Trends. In *Materials Science Forum*.
- [20] Marino, M., Pattni, S., Greenberg, M., Miller, A., Hocker, E., Ritter, S. and Mehta, K., 2015, October. Access to prosthetic devices in developing countries: Pathways and challenges. In *Global Humanitarian Technology Conference (GHTC), 2015 IEEE* (pp. 45-51). IEEE.
- [21] Laferriere, J.Z., Groff, A., Hale, S. and Sprunger, N.A., 2018, A Review of Commonly Used Prosthetic Feet for Developing Countries: A Call for Research and Development *Journal of Novel Physiotherapies*, Laferriere et al., *J Nov Physiother* 2018, 8:1, DOI: 10.4172/2165-7025.1000380.

- [22] Icrc.org. (2015). Prosthetics – orthotics thermoforming polypropylene (draping technique) - ICRC. [Online] Available at <https://www.icrc.org/en/doc/resources/documents/publication/p0868-1.htm> [Accessed 12 Jan. 2018].
- [23] Taylor, D.A., Gilbert, J.C. and Lautenschlager, E.P., 1992. Testing of composite materials used in orthotics and prosthetics. *J Assoc Child Prosthet Orthot Clin*, 27(2), p.62.
- [24] Professionals.ottobockus.com. (2019). Ottobock US Healthcare | Homepage. [Online] Available at <https://professionals.ottobockus.com> [Accessed 3 Mar. 2016].
- [25] Valenti, T. (1990). Experience with Endoflex: A Monolithic Thermoplastic Prosthesis for Below-Knee Amputees. *JPO Journal of Prosthetics and Orthotics*, 3(1), pp.43-50.
- [26] Tegegne, A. and Yilma, Y. (2017). Production of Prosthetics and orthotics materials with improved tensile strength and elongation at break from venial acetate, low density polyethylene and additive blends. *International Journal of Engineering Trends and Technology*, 52(3), pp.162-174.
- [27] Carpenter, M., Hunter, C. and Rheume, D. (2008). Testing and Analysis of Low Cost Prosthetic Feet. [online] Digital WPI. Available at: <https://digitalcommons.wpi.edu/atrc-projects/8>.
- [28] Icrc.org. (2006). Trans-Tibial Prosthesis - ICRC. [Online] Available at <https://www.icrc.org/en/doc/resources/documents/publication/p0868-1.htm> [Accessed 12 Jan. 2018].
- [29] Endolite USA - Lower Limb Prosthetics. (2018). Javelin - Carbon, Feet, Sandal Toe, Waterproof Feet - Endolite USA - Lower Limb Prosthetics. [Online] Available at <https://www.endolite.com/products/javelin> [Accessed 5 Sep. 2018].
- [30] Prnewswire.com. (2019). Global and China Carbon Fiber and CFRP Industry Report, 2017-2021. [Online] Available at <https://www.prnewswire.com/news-releases/global-and-china-carbon-fiber-and-cfrp-industry-report-2017-2021-300428040.html> [Accessed 10 Jan. 2019].
- [31] Park, S.H., 2018. Types and Health Hazards of Fibrous Materials Used as Asbestos Substitutes. *Safety and Health at Work*.
- [32] Wernick, I.K. and Themelis, N.J., 1998. Recycling metals for the environment. *Annual Review of Energy and the Environment*, 23.

- [33] Winter, D.A., 2009. Biomechanics and motor control of human movement. John Wiley & Sons, 4th edition, ISBN: 978-0-470-39818-0.
- [34] Matweb.com. (2018). Online Materials Information Resource - MatWeb. [Online] Available at <http://www.matweb.com> [Accessed 1 Sep. 2018].
- [35] AZoM.com. (2019). Material Science | News | Materials Engineering | News. [Online] Available at <https://www.azom.com> [Accessed 4 Sep. 2018].
- [36] Marasović, T., Cecić, M. and Zanchi, V., 2009. Analysis and interpretation of ground reaction forces in normal gait. WSEAS transactions on systems, 8(9), pp.1105-14.
- [37] Gao, S., Yang, S., Xue, M. and Cui, C., 2008. Total deformation and its role in heavy precipitation events associated with deformation-dominant flow patterns. Advances in Atmospheric Sciences, 25(1), pp.11-23.
- [38] Varnes, D.J., 1962. Analysis of plastic deformation according to von Mises' theory, with application to the South Silverton area, San Juan county, Colorado (No. 378-B). US Govt. Print. Off.
- [39] Donato, G.H. and Bianchi, M., 2011. Numerical modeling of uneven thermoplastic polymers behaviour using experimental stress-strain data and pressure dependent von Mises yield criteria to improve design practices. Procedia Engineering, 10, pp.1871-1876.
- [40] Iorga, C., Desrochers, A. and Smeesters, C., 2012. Engineering design from a safety perspective. Proceedings of the Canadian Engineering Education Association (CEEA) Conf, CEEA12; Paper 005 Winnipeg, MB.
- [41] Pawar, P., Ballav, R., and Kumar, A., 2016. Finite Element Method Broach Tool Drilling Analysis Using Explicit Dynamics Ansys. International Journal of Modern Manufacturing Technologies, 8(2), pp.54-60.
- [42] M.alibaba.com. (2018). Source Manufacturers, Suppliers, Exporters & Importers on m.alibaba.com. [Online] Available at <https://m.alibaba.com> [Accessed Sep. 2018].
- [43] Lynn, R., Saldana, C., Kurfess, T., Reddy, N., Simpson, T., Jablokow, K., Tucker, T., Tedia, S. and Williams, C., 2016. Toward rapid manufacturability analysis tools for engineering design education. Procedia Manufacturing, 5, pp.1183-1196.
- [44] Venkata Ramesh Mamilla, Srinivasulu M, Mani Prasad N., 2016, Study on computer numerical control (CNC) machines, International Journal of Advanced Scientific Research, Available at: (www.newresearchjournal.com/scientific), 1(1); PP. 21-25, ISSN: 2456-0421.

[45] Colombo, C., Marchesin, E.G., Vergani, L.A.U.R.A., Boccafogli, E. and Verni, G., 2011. Design of an ankle prosthesis for swimming and walking. *Procedia Engineering*, 10, pp.3503-3509.

[46] Al-Khazraji, K., Kadhim, J. and Ahmed, P.S., 2012, July. Tensile and fatigue characteristics of lower-limb prosthetic socket made from composite materials. In *Proc. of the 2012 International Conference on Industrial Engineering and Operations Management Istanbul, Turkey* (pp. 843-852).