

Chapter Two

Literature Review

2.1 Background of ZFG Backwash Filter

The Backwash filter (ZFG) is designed for different kinds of feeds (Vacuum Gasoil, Heavy Coker Gas, Diesel oil, Vacuum Resides). The Backwash filters Prevents catalyst bed plugging by stopping solids from entering and building up in the beds. No reactor has ever been shut down prematurely due to feed stream solids plugging catalyst beds when equipped with automatic backwashing filter. The filters will lower the overall operating costs, extends reactor run times, get maximum performance out of expensive catalyst and results in higher production rates. The filter consists of six banks paired to common headers. The number of elements per bank and the number of banks in a system are based on the required Flow rate and the viscosity. A major feature of the filter is its automatic backwashing capability as the filter can be washed automatically without shutting down the plant or interrupting the process continuity. The filter enters into the Distributed control system (DCS) directly through the differential pressure signal. Because only one pair of elements is cycled for backwashing at a given time, the filter is always on stream providing uninterrupted service. During filtration mode, liquid flow through ball valve to filter elements form bottom to top and filter element stop all the contaminants that may build up on the surface of the elements, and reduce the effective open area, consequently the differential pressure across the filter increased and at a preset value a differential pressure transmitter activates a solenoid valve so as to sends a pneumatic start signal to the programmer, which will send

programmed pneumatic signal to pneumatic actuator and the actuator will shut off filling valves while opening backwashing valves in sequence. One Bank (pair of elements) is in backwashing while the others Banks in filtration mode. After the whole system has been backwashed the programmer is automatically reset until the rising of a differential pressure again initiates a signal [1].



Figure 2-1: DHT Unit Backwash Filters

2.1.1 Pneumatic Control System Components of BWF

Pneumatic programmer is total pneumatic control system, which consists of several peripheral mentioned below and shown on Figure 2-2:

1. Pneumatic logical circuit.
2. Quick stepper controller.
3. Time delay valves with switch on delay, VZ-3-PK-3.
4. Pneumatic bistable 3/2 valve, J-3-PK-3.
5. Pneumatic bistable 5/2 valve, J-5-PK-3.
6. Short pulse valve, model Vlk-3-PK-3.
7. Solenoid valves.



Figure 2-2: Pneumatic Control System Components

2.1.1.1 Pneumatic Quick stepper Controller

The Quick stepper is a mini control system with 12 switching steps. It has highly safe mode of operation as each given switching step cannot begin until the preceding steps has been executed. Only one output at time is fed with compressed air, in order corresponding to the input sequence of the switching steps while all the other outputs are exhausted. The selected step is activated, when the switch is set to 1, then the pressure is fed to the activated output. When the switch is at 0, the outputs are disabled; and the steps controlled manually. Two indicators are used, the white pressure indicator is for the activated output and the blue pressure indicator is for the acknowledgement signal from last step to be executed. When the port L (reset) is activated, the step indicator always advances to the last step (12) and the step counter for steps 1 to 12 are shown with upward counting function. The Quick stepper has the additional safety feature that it will switch only when continuous signal is present at the auto port and no manual intervention can be made while the Quick stepper is running in automatic mode [2].



Figure 2-3: Pneumatic Controller- Quick stepper –C

2.1.1.2 Time delay valve VZ-3-PK-3 Part number: 5755

The time delay valve consists of a pneumatically actuated 3-way valve and an upstream throttle with additional volume. The directional control valve is activated with a delay depending on the setting of the throttle. It is reset via a mechanical spring. The function of two relay valves is to adjust the time interval of two cylinder operations and extending retention time of single cylinder [2].

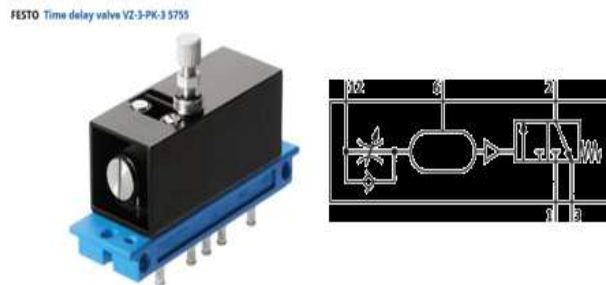

Figure 2-4: Time delay valve VZ-3-PK-3

2.1.1.3 Pneumatic valve J-3-PK-3 Part number: 10772

The air pilot valve is 3/2 bistable valve, and is used to control the direction of the Air. The function of this valve is to stop the backwashing process after the operation cycles complete [2].

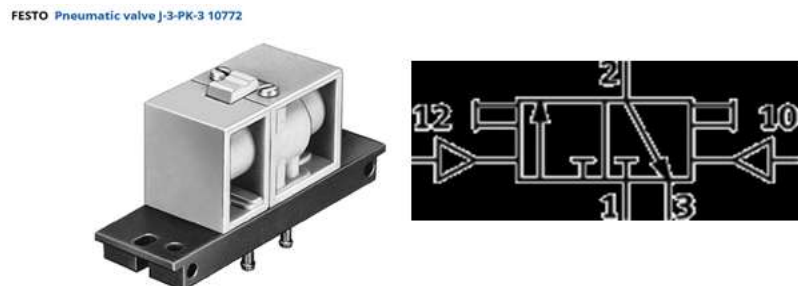

Figure 2-5: Pneumatic valve J-3-PK-3 Part number

2.1.1.4 Pneumatic valve Part number: J-5-PK-3-4 4503

The air pilot valve is 5/2 bistable valve. The standard nominal flow rate is 105 l/min, operating pressure is between 1~8 bar, design structure is poppet seat, nominal size is 2, 5 mm, switching time reversal is 9 ms, ambient temperature is between 0~60 °C, and the weight is 130 g [2].

FESTO Pneumatic valve J-5-PK-3 4503

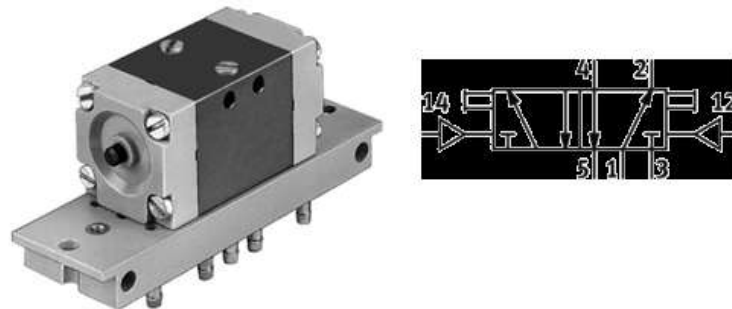

Figure 2-6: Pneumatic valve Part number: J-5-PK-3-4

2.1.1.5 Short pulse valve- vlk-3-PK-3-Part number: 9636

The one-shot valve generates a brief pulse for continuous pulse. When pressure is applied, 1 is linked to 2 simultaneously the pilot pressure rises via a nozzle bore and switches the valve and this causes 1 to be closed and 2 to be vented. The valve is reset only after 1 is vented. The pulse duration is pressure-controlled and is not adjustable [2].

FESTO Short pulse valve VLK-3-PK-3 9636

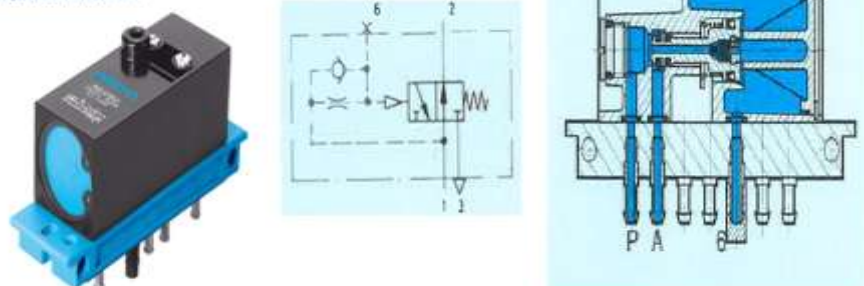

Figure 2-7: Short pulse valve- vlk-3-PK-3

2.2 PC4000 Backwash filter controller

PC4000 is a programmable control center for automatic filtration and backwash with true duplex remote operation. It introduces a new standard of sophistication in automated water treatment for many applications such as swimming pools, cooling towers and industrial water treatment [3].

2.2.1 Features of PC4000 Filter Controller

- Programmable Recirculation Pump Control.
- Flow monitoring and Totaling with safety alarm.
- Influent/Effluent Pressure monitoring with safety alarms.
- Interlock with Chemistry Controller.
- Waste PIT and Surge PIT alarm.
- Automated backwash for single or multiple filters.
- Works with Pneumatic, Hydraulic or Electric Valves.
- Eight (8) Backwash Programs.
- Priority valve program.
- Heater Control with fireman safety and energy saver program.
- Remote computer operation and Graphic Data Display.



Figure 2-8: The Chemtrolm PC4000 controller

2.3 CS400™ Commercial Backwash Filter Controller

The CS400™ Backwash Controller is semi-automatic programmable controller which can backwash up to six (6) filters in sequence via the integral multi-port pressure distribution valve. A backwash can be initiated in three ways: true semi-automatic backwash at the single touch of a button, via an external signal from a master filter room controller or by a signal from an optional differential pressure switch for basic, automatic backwash functionality. The features include user-configurable settings, alarms, automatic calculated backwash cycle time, valve control to ensure pump and heater protection prior to the start of the backwash cycle [4].

2.3.1 Features of CS400™ Controllers

- Multi-port pressure distribution valve actuate diaphragm-style backwash valves using city water pressure or compressed air.
- Calculated backwash cycle time.
- Stored backwash data and history.
- Alarms.
- LCD Display.



Figure 2-9 CS400™ Commercial Backwash Controller

2.4 GB8 Electronic Backwash Filter Controller

The GB8 is the automatic state of the art electronic backwash controllers. The control system coming with solenoids, differential pressure sensor, backwash counter, and an emergency alarm output. The GB8 controller backwash multiple filters, 4-8 or 12. The filters can be cleaned in 3 different modes: D/P, timer, and manual. They are available in 115/230 volts or are battery operated 12VDC. The solenoid needs to be energized to open the flushing valve. The controller will sequence the filters to rinse one at a time [5].

2.4.1 Features of GB8 Electronic Controller

- LCD Display Panel.
- Backwash Counter.
- Weather proof metal enclosure.
- Rinsing D/P. Timer, Manual.
- Periodic – Timer setting.
- Dwell – Waiting time between filters rising.



Figure 2-10: GB8 Electronic Controller

2.5 AUTO-EC-2-E Electric Backwash Filter Controller

The AUTO-EC-2 Backwash Controller is designed to monitor and activate the cleaning cycle for a single filter or two filters in parallel. The controller allows the user to adjust the Flushing duration, Dwell time between backwashes, and the specified periodic backwash. [6].

2.5.1 Features of AUTO-EC-2-E Controller

- Manual Start.
- Backwash and Dwell Time setting.
- Backwashing Duration of each flush cycle.
- Backwashing Counter.
- Displays the number of backwashes.
- Preset time for scheduled backwash cycles.
- Alarm and Counter reset.

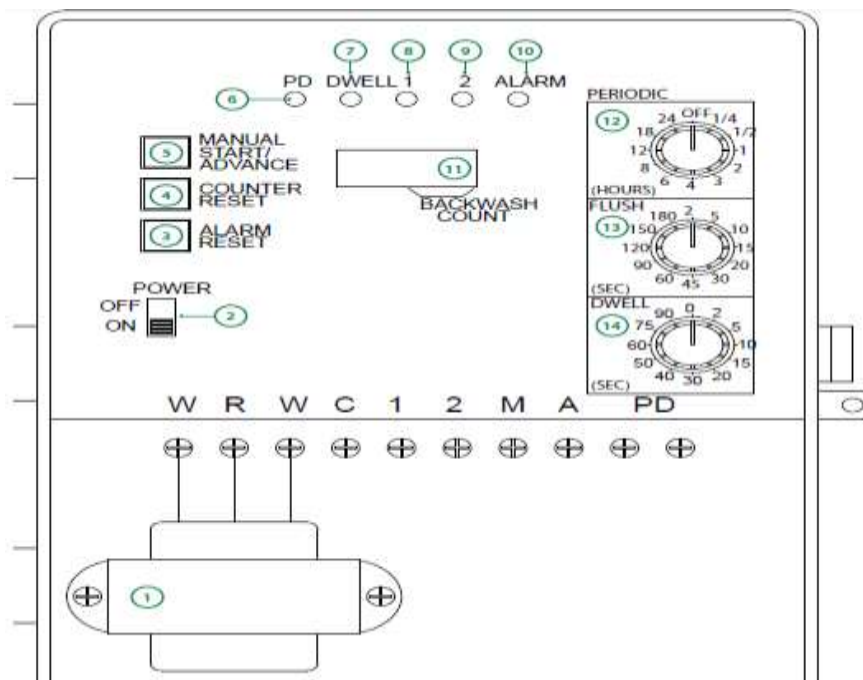

Figure 2-11: AUTO-EC-2-E Electric Filter Backwash Controller

2.6 Rain Bird Synergy Automatic Backwash Controller

The Rain Bird is the most cost-effective automatic control filtration system which allows fully unattended operation. All Rain Bird controllers monitor system operation on both pressure differential and elapsed time [6].

2.6.1 Features of Rain Bird Synergy Controller

- 16-station output.
- Operates up to 2 valves per station plus a master valve.
- Selectable input power: 110V AC, 220V AC, or 12V DC.
- Backwash on time stamp, elapsed time or Pressure differential.
- Programmable filter-backwash frequency, duration and delay.
- Manual start with station advance and stop.
- Water and bug resistant enclosure.
- Pre-dwell 0-5 minutes.
- Continuous backwash
- High pressure with automatic pump.



Figure 2-12: Rain Bird Synergy Automatic Controller

2.7 Leopold® FilterWorx™ Automatic Backwash Control System

The FilterWorx™ Automatic Control System by Leopold is a complete filter control package consisting of all instrumentation and control equipment for the automatic monitoring and control of municipal water filtration systems. The control system designed to keep a constant watch on the essential parameters of the processes in your filter plant.

Features of FilterWorx™ Automatic Control System

- Continuously monitors effluent water quality and condition of the filter media to ensure optimum filtration.
- Automatically adjusts flow rates to compensate for customer demand changes.
- Standard communications protocols that allow easy integration into most other plant DCS and SCADA systems.
- Automatically initiate and control the backwash sequence, which means the filter is cleaned when it needs to be cleaned.
- Filter run times and product quality are optimized at the lowest possible cost.
- Control flow rate changes and automatically sequence equipment properly to avoid surges and potentially disastrous upsets which can damage your system and cost you money.