

**Sudan University of Science and Technology**

**College of Engineering**

**Electrical Engineering Department**



**CRUDE OIL PUMP STATION MONITORING AND  
CONTROLLING DEPEND ON PLC BASED**

المراقبه والتحكم لمحطة ضخ خام البترول إعتماًداً على أساس وحدة  
التحكم المنطقي القابل للبرمجه ال PLC

*A Project Submitted in Partial Fulfillment of the Requirements for*

*The Degree of B.Tech. In Electrical Engineering*

**Prepared By:**

1. Mutasim Abdallah Mohammed Elawad
2. Musaab Mahjoub Allbany Hamad
3. Mozammil Fadl Elmola Mustafa Fadl Elmola
4. Hisham Abdelaziz Osman Mohamed Ahmed

**Supervised By:**

Dr: Awadalla Taifour Ali

**October - 2018**

## الآيه

بسم الله الرحمن الرحيم

يقول الله تعالى: { اقرأ باسم ربك الذي خلق \* خلق

الإنسان من علق \* اقرأ وربك الأكرم \* الذي علم

بالقلم \* علم الإنسان ما لم يعلم }

سورة العلق

رقم الآية (1 - 5)

# **DEDICATION**

TO OUR PARENTS, BROTHERS, SISTERS AND WIVES  
WHO SHOWN US THE ART OF LIVING  
TO OUR TEACHERS WHO TAUGHT US THE SPIRIT OF  
EXPLORATION

# ACKNOWLEDGMENTS

It would be impossible without people who supported us and believed in us. We would like to extend our gratitude and our sincere thanks to our honourable, esteemed supervisor Dr: Awadalla Taifour Ali, he is not only a helpful teacher with deep vision but also most importantly a kind person. We sincerely thank for his exemplary guidance and encouragement. His trust and support inspired us in the most important moments of making right decisions and we are glad to work with him. we would like to thank all my friends for all the thoughtful and mind simulating discussion we had, which make us to think beyond the obvious.

We would like to thank all those who support us in academy of engineering and sciences and all the people who an unforgettable and rewarding experience.

Last but not least we would like to thank our parents, who taught us the value of hard work by their own example.

# **ABSTRACT**

The proposed system provides simulation analysis and components for the implementation of the automatic level control system with the help of the Programmable Logic Controller (PLC), the distribution control system (DCS) and the Supervisory Control and Data Acquisition (SCADA). An automatic pattern has been created in the proposed model, which can effectively supervise of controlling the tank by the presence of sensors if the level of the tank is changed and the PLC program. This data is used to make the required decisions for the pump by turning (on and off) and manual mode is configured to override Automatic system.

Our proposed system can be divided into three main models (sensor, decision and implementation).

In other words, PLC connects the state of the system through the human machine interface (HMI) from the external physical state to the visual reality supervision state.

## مستخلص

يوفر النظام المقترح تحليلاً للمحاكاة ومكونات لتنفيذ نظام التحكم على المستوى التلقائي وذلك بمساعدة وحدة التحكم المنطقي القابلة للبرمجة (PLC) و نظام التحكم في التوزيع (DCS) والتحكم الإشرافي وحياسة البيانات (SCADA) .

تم إنشاء نمط او محاكاة تلقائي في النموذج المقترح بحيث يمكن أن يشرف بشكل فعال على مستوى هذه البيانات ؛ وذلك بالتحكم في مستوى الخزان بتواجد مستشعرين يتغيران في حالة تبديل المستوى وبرنامج ال PLC المستخدم وجد لاتخاذ القرارات المطلوبة للمضخة وذلك بال (التشغيل والإيقاف) بالإضافة إلى الوضع اليدوي تم تكوينه لتجاوز النظام التلقائي.

يمكن تقسيم نظامنا المقترح إلى ثلاثة نماذج رئيسية (الاستشعار ، واتخاذ القرار ، ثم التنفيذ) ؛ أي بمعنى أن ال PLC يقوم بتوصيل حالة النظام من خلال واجهة او شاشة الكمبيوتر من الوضع الفيزيائي الخارجي الى وضع إشراف الواقع المرئي.

# ABBREVIATIONS

PLC	Programmable Logic Controller
RTU	Remote Terminal Unit
DCS	Distributed Control System
SCADA	Supervisory Control And Data Acquisition
PS	Pump Station
AI/AO	Analog input/output
DI/DO	Digital input/output
TC	Thermo-Couples
RTD	Resistance Temperature Detectors
HMI	Human Machine Interface
CPU	Central Processor Unit
CCU	Central Control Unit
TTL	Transistor-Transistor Logic
CMOS	Complementary Metal Oxide Silicon
FPF	Field Production Facility
CPF	Central Production Facility
MAOH	Maximum Allowable Operating Head
IED	Intelligent Electronic Device
MCC	Motor Control Circuit
PC	Personal Computer
MTBF	Means Time Before Failure
MTTR	Means Time To Repair

# TABLE OF CONTENTS

	<b>Page</b>
الآية	i
<b>DEDICATION</b>	ii
<b>ACKNOWLEDGEMENT</b>	iii
<b>ABSTRACT</b>	iv
المستخلص	v
<b>ABBREVIATIONS</b>	vi
<b>TABLE OF CONTENT</b>	vii
<b>CHAPTER ONE INTRODUCTION</b>	1
1.1 General	1
1.2 Problem statement	2
1.3 Objectives	2
1.4 Methodology	2
1.5 layout	2
<b>CHAPTER TWO LITERATURE REVIEW</b>	3
2.1 PLC	3
2.1.1 Power supply	5
2.1.2 Input systems	5
2.1.3 Outputs	7
2.1.4 Central processor unit (real time)	8
2.1.5 Memory unit	9
2.1.6 Programmer units	10
2.1.7 Peripheral devices	11
2.1.8 Differences between computers and PLC	12
2.2 RTU	12
2.2.1 RTU Architecture	12
2.2.2 Power supply	13
2.2.3 Digital (Status) Inputs	13
2.2.4 Analog Inputs	13
2.2.5 Digital (control relay) Outputs	14
2.2.6 Analog Outputs	14
2.2.7 Software and logic control	14
2.2.8 Communications	14
2.2.9 Applications	15



2.3 DCS	16
2.3.1 DCS Technical points	16
2.3.2 DCS Communications	18
2.3.3 DCS Hardware	18
2.3.4 DCS Reliability	19
2.3.5 DCS Alarm Management	20
2.3.6 DCS technical accessories	20
2.3.7 DCS operator station	21
2.3.8 Typical application	21
2.4 SCADA	21
2.4.1 The SCADA concept in control operations	22
2.4.2 SCADA system components	24
2.4.3 Communication infrastructure and methods	25
<b>CHAPTER THREE CRUDE OIL PUMPS STATION COMPONENTS</b>	<b>27</b>
3.1 Introduction	27
3.2 Pumps	29
3.3 Engine's driver (mechanical power)	33
3.4 Generator (electrical power)	34
3.5 Control room	35
3.6 Heating station.	35
3.7 Air compressors	37
3.8 By pass system	39
3.9 Block valves:	39
3.10 Storage tank.	40
<b>CHAPTER FOUR PUMP STATION SYSTEM IMPLEMENTATION</b>	<b>42</b>
4.1 Tools requirement	42
4.2 System implementation	43
4.3 Case study	48
<b>CHAPTER FIVE CONCLUSION &amp; RECOMMENDATIONS OF FUTURE WORK</b>	<b>54</b>
5.1 Conclusion	54
5.2 Recommendations	55
<b>REFERENCES</b>	<b>56</b>

# CHAPTER ONE

## INTRODUCTION

### 1.1 Back ground

Pumping stations are facilities including pumps and equipment for pumping fluids from one place to another. They are used for a variety of infrastructure systems, such as the supply of water to canals, the drainage of low-lying land, and the removal of sewage to processing sites. A pumping station is, by definition, an integral part of a pumped-storage hydroelectricity installation.

The pump manufacturers have always designed and manufactured electronic devices to control and supervise the pumping stations. Today it is also very common to use a (PLC) or (RTU) to do such work, but the experience needed to solve certain particular problems, makes an easy choice to look for a specific pump controller. RTUs are very helpful in remote monitoring of each pumping station from a centralized control room with SCADA systems. This setup can be helpful in monitoring pump faults, levels or any other alarms and parameters making it more efficient. And the manufacturers have always designed and manufactured electronic devices to control and supervise the pumping stations. Today it is also very common to use a (PLC) or (RTU) to do such work, but the experience needed to solve certain particular problems, makes an easy choice to look for a specific pump controller. RTUs are very helpful in remote monitoring of each pumping station from a centralized control room with SCADA systems. This setup can be helpful in monitoring pump faults, levels or any other alarms and parameters making it more efficient.

## 1.2 Problem statement

The project problem statement discussed about the optimum operational methods for crude oil pump station. Additional to field equipments trouble shooting like (oil tank level switch).

## 1.3 Objective

The main objectives of our project:

- To optimization the daily operations of a pumping plant.
- To saving time with regularity and minimization the faults by using the automation control.
- To show the difference between manual human controlling and automatic controlling via PLC. Which its very promising results have been obtained.

## 1.4 Methodology

- Identified and categorised the equipments at crude oil pump station monitoring & controlling by DCS by using PLC.
- Used the ABB Automation Company freelance emulation program for sample of oil tank with feeder & booster pumps.
- Proposed a concept case study of level switched & recommend support tools to design the proper crude oil pump stations.

## 1.5 Layout

This project is organized as follows:-

**Chapter one** reviewed the general information of our project like introduction, objective, methodology and layout.

**Chapter two** presents the literature review of the PLC, RTU, DCS and SCADA.

**Chapter three** deliberates the pump station of Petrodar operation company components at pipe line.

**Chapter four** illustrate the PLC system implementation by controlling the pump for filling and discharge from oil tank.

**Chapter five** will go through the conclusion and recommendation for future study.

# CHAPTER TWO

## LITERATURE REVIEW

### 2.1 PLC

During the past decade, the capabilities of (PLCs) and (DCS) have changed to the extent that today many applications that used to be the exclusive province of one or the other can be handled by both. PLCs were developed by manufacturers who had been making relays for logic and interlock applications, while DCS systems were developed by process control manufacturers, having substantial experience in PID-type analog control.

PLC is an industrially hardened computer-based unit that performs discrete or continuous control functions in a variety of processing plant and factory environments. Originally intended as relay replacement equipment for the automotive industry, the PLC can now be found in some part of virtually every type of industry imaginable. The programmable controller is produced and sold worldwide as stand-alone equipment by at least 10 major control equipment manufacturers.

Table 1.1 lists some of the milestones in the development of Plus. The automotive industry fostered the development of the PLC primarily because of the massive rewiring that had to be done every time a model change occurred. Solid-state logic is much easier to change than relay panels, and this advantage was reflected in the cost of installing and operating the PLC instead of traditional relay systems.

Table 1.1: History of programmable logic controllers (Plus)

1968	Design of Plus developed for General Motors Corporation to eliminate costly scrapping of Assembly-line relays during model changeovers.
1969	First Plus manufactured for automotive industry as electronic equivalents of relays.
1971	First application of plus outside the automotive industry.
1973	Introduction of "smart" Plus for arithmetic operations, printer control, data move, matrix Operations, CRT interface, etc.

1975	Introduction of analog PID (proportional, integral, derivative) control, which made possible The accessing of thermocouples, pressure sensors, etc.
1976	First use of plus in hierarchical configurations as part of an integrated manufacturing system.
1977	Introduction of very small plus based on microprocessor technology. Plus gain wide acceptance, sales, approach \$80 million.
1979	Integration of plant operation through a PLC communication system.
1980	Introduction of intelligent input and output modules to provide high-speed, accurate control In positioning applications.
1981	Data highways enable users to Interconnect many Plus up to 15,000 feet from each other. More 16-bit Plus becomes available. Colour graphic CRTs are available from several suppliers.
1982	Larger Plus with up to 8192 I/O becomes available.
1983	"Third party" peripherals, including graphic CRTs, operators' interfaces, "smart" I/O networks, Panel displays, and documentation packages, become available from many sources.

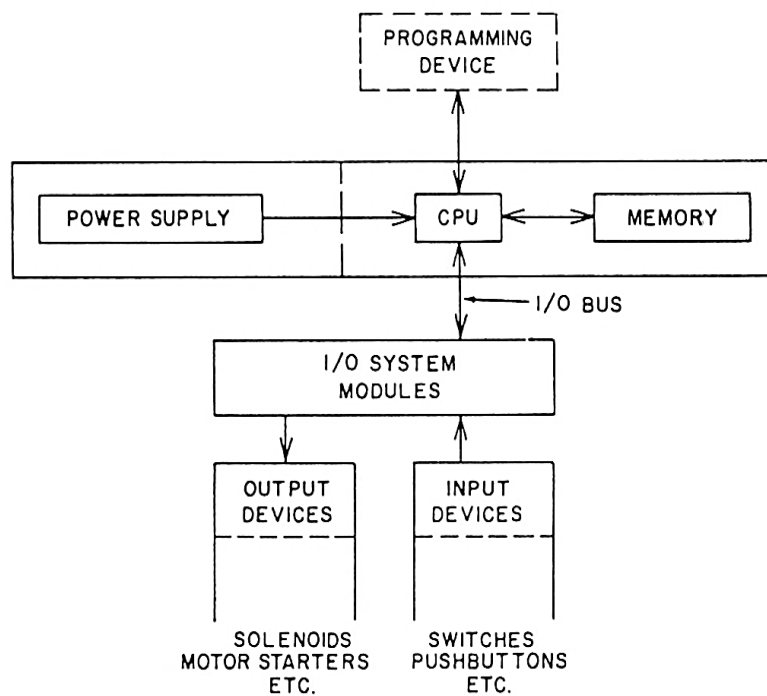

**Figure 2.1: PLC architecture.**

A programmable controller manufactured by any company has several common functional parts. Figure.21 illustrates a generic PLC architecture. The diagram shows power supply, I/O, central processor, memory, and programming and peripheral device subsections. Each is discussed below.

### **2.1.1 Power Supply**

The power supply may be integral or separately mounted. It always provides the isolation necessary to protect solid-state components from most high-voltage line spikes. The power supply converts power line voltages to those required by the solid-state components. All PLC manufacturers provide the option to specify line voltage conditions. In addition, the power supply is rated for heat dissipation requirements for plant floor operation. This dissipation capability allows Plus to have high-ambient-temperature specifications and represents an important difference between programmable controllers and personal computers for industrial applications.

The power supply drives the I/O logic signals, the central processor unit, the memory unit, and some peripheral devices. As I/O is expanded, some Plus may require additional power supplies in order to maintain proper power levels. The additional power supplies may also be separate or part of the I/O structure.

### **2.1.2 Input systems**

Inputs are defined as real-world signals giving the controller real-time status of process variables. These signals can be analogue or digital, low or high frequency, maintained or momentary. Typically they are presented to the programmable controller as a varying voltage, current, or resistance value. Signals from thermocouples (TCs) and resistance temperature detectors (RTDs) are common examples of analogue signals. Some flow meters and strain gauges provide variable frequency signals, while pushbuttons, limit switches, or even electromechanical relay contacts are familiar examples of digital, contact closure type signals.

One additional type of input signal, the register input, reflects the computer nature of the programmable controller. The register input is particularly useful when the

process condition is represented by a collection of digital signals delivered to the PLC at the same time. A binary coded decimal (BCD) thumbwheel is a good example of an input device that is compatible with a register input port. If the thumbwheel represented three and one-half digits of process data, then all fourteen data output wires from the thumb-wheel would provide their digital signal directly to the programmable controller register input unit, which would, in turn, signal condition and transfer the data to the central processor unit.

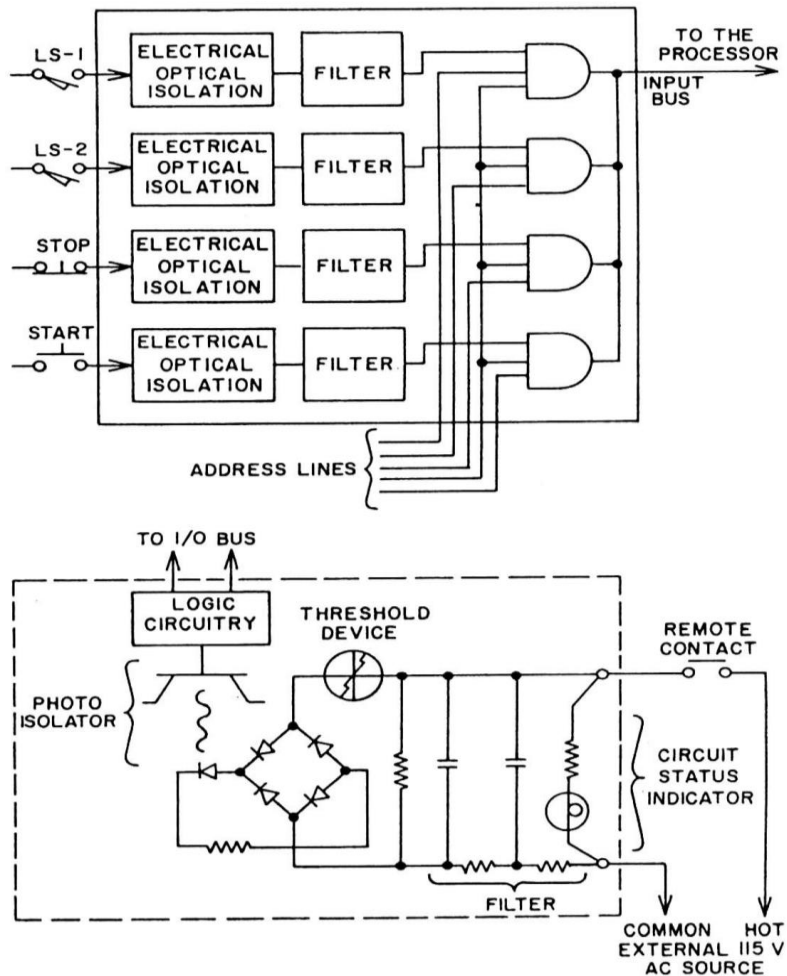

**Figure 2.2:** Typical input area; typical AC input unit.

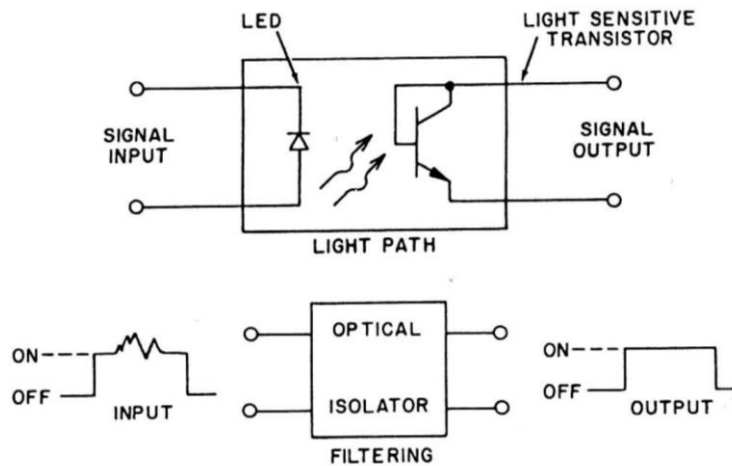

Figure 2.3: Electrical optical isolator.

### 2.1.3 Outputs

There are three common categories of outputs: discrete, register, and analog. Discrete outputs can be pilot lights, solenoid valves, or annunciator windows (lamp box).

Register outputs can drive panel meters or displays; analog out-puts can drive signals to variable speed drives or to I/P (current to air) converters and thus to control valves.

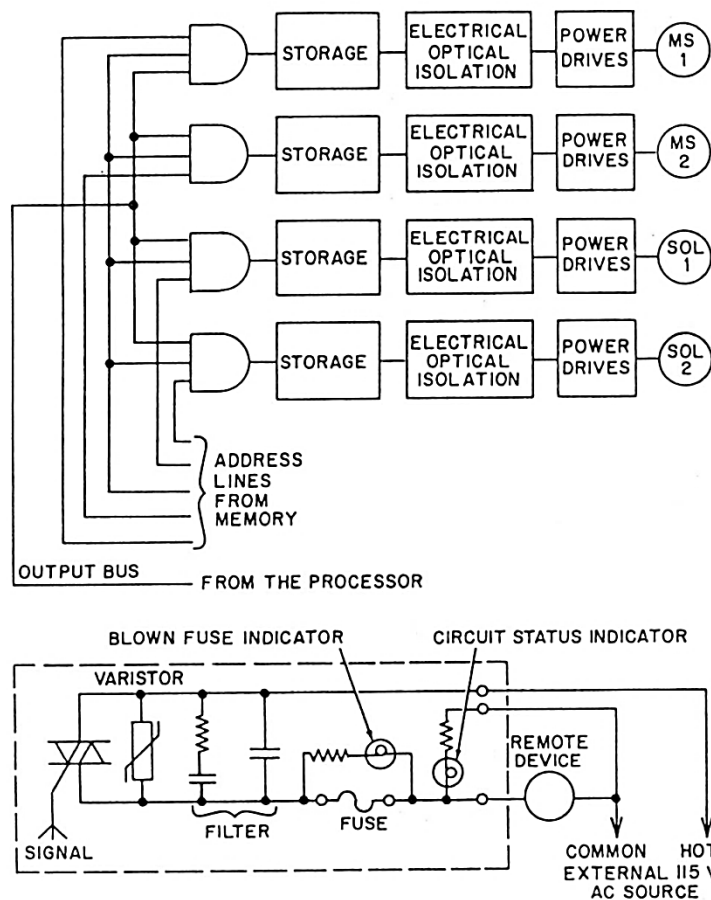

Figure 2.4: Typical output area; typical AC output unit.



Most I/O systems are modular in nature; that is, a system can be arranged by use of modules that contain multiples of I/O points. These modules can be composed of 1, 4, 8, or 16 points and plug into the existing bus structure. The bus structure is really a high-speed multiplexer that carries information back and forth between the I/O modules and the central processor unit. Higher point densities are possible, but their selection may involve a trade-off in wire size used, as well as in ease of wire harness installation to the module.

One of the most important functions of the I/O is its ability to isolate real-world signals (0 to 120 V AC, 0 to 24 V DC, 4 to 20 mA, 0 to 10 V, and thermocouples) from the low signal levels (typically 0 to 5 V DC MAX) in the I/O bus. This is accomplished by use of optical isolators, which trigger a process switch to transfer data in (input module) or out (output module) to a solenoid valve without violating bus integrity. Typical discrete I/O schematics are shown in Figures 2.2, 2.3, and 2.4.

#### **2.1.4 Central Processor Units (Real Time)**

The central processor unit (CPU), or central control unit (CCU), performs the tasks necessary to fulfil the PLC function. Among these tasks is scanning, I/O bus traffic control, program execution, peripheral and external device communications, special function or data handling execution (enhancements), and self-diagnostics.

Central processing units can use TTL (transistor-transistor logic), CORE (ferrite cores), or CMOS (complementary metal oxide silicon) technology or can be microprocessor-based (VLSI). Although TTL is faster (faster scan times), CORE requires no battery backup, CMOS is more compact and requires lower power levels, and microprocessor-based systems are both more powerful and more flexible. Generally, trade-offs must be made between speed and special features. It should be noted that the CPU and memory units are considered separate functions.

One common way of rating how a PLC performs these tasks is its scan time. Scan time is roughly defined as the time it takes for the programmable controller to interrogate the input devices, execute the application program, and provide updated signals to the output devices. Scan times can vary from 0.1 milliseconds per 1 K

(1024) words of logic to more than 50 milliseconds per 1K of logic. Although scan times are often given as performance measures, there are factors that make them misleading. Word size varies from 4 bits to 32 bits depending on the PLC model and manufacturer. Special features, which vary from pre-programmed drum times to full floating point mathematics, have different processing times and may generate longer scan times. Therefore, when selecting a programmable controller other performance factors must be considered. The user should take into account the application as well as the speed of the controller. Generally speaking, process applications need to take advantage of microprocessor power, whereas machine control applications are usually more concerned with program execution speed.

### **2.1.5 Memory Units**

The memory unit<sup>7</sup> of the PLC serves several functions. It is the library where the application program is stored. It is also where the PLC's executive program is stored. An executive program functions as the operating system of the PLC. It is the program that interprets, manages, and executes the user's application program. Finally, the memory unit is the part of the programmable controller where process data from the input modules and control data for the output modules are temporarily stored as data tables. Typically, an image of these data tables is used by the CPU and, when appropriate, sent to the output modules.

Memory can be volatile or non-volatile. Volatile memory is erased if power is removed. Obviously, this is undesirable, and most units with volatile memory provide battery backup to ensure that there will be no loss of program in the event of a power outage. Non-volatile memory does not change state on loss of power and is used in cases in which extended power outages or long transportation times to job site (after program entry) are anticipated.

The basic programmable controller memory element is the word. A word is a collection of 4, 8, 16, or 32 bits that is used to transfer data about the programmable controller. As word length increases, more information can be stored in a memory

location. Even with the ambiguity associated with word length, programmable controllers that provide the equivalent of 32K of 8-bit memory locations can execute application programs that are moderately complicated and interact with 50 to 100 discrete I/O points. More details about programmable controller memory and computer memory in general are available.

### **2.1.6 Programmer units**

The programmer unit provides an interface between the PLC and the user during program development, start-up, and troubleshooting. The instructions to be performed during each scan are coded and inserted into memory with the programmer.

Programmers vary from small hand-held units the size of a large calculator to desktop stand-alone intelligent CRT-based units. These units come complete with documentation, reproduction, I/O status, and on-line and off-line programming ability. Many PLC manufacturers now offer controller models that can use a personal computer as the programming tool. Under these circumstances, the manufacturer will sell a program for the personal computer that usually allows the computer to interface with a serial input module installed in the programmable controller.

Programming units are the liaison between what the PLC understands (words) and what the engineer desires to occur during the control sequence. Some programmers have the ability to store programs on other media, including cassette tapes and floppy disks. Another desirable feature is automatic documentation of the existing program. This is accomplished by a printer attached to the programmer. With off-line programming, the user can write a control program on the programming unit, then take the unit to the PLC in the field and load the memory with the new program, all without removing the PLC. Selection of these features depends on user requirements and budget. On-line programming allows cautious modification of the program while the PLC is controlling the process or the machine.

## 2.1.7 Peripheral Devices

Peripheral devices are grouped into several categories: programming aids, operational aids, I/O enhancements, and computer interface devices are the most common.<sup>5</sup> Each category is described below.

Programming aids provide documentation and program recording capabilities. Although some devices can program many models of different manufacturers' plus, most are dedicated to single suppliers and specific models. The definite trend in programming aids is PC-compatible software that allows the programmable controller to be emulated by the personal computer. This software is sold by the PLC manufacturer or a licensee and is often model-specific. If the software also offers on-line programming and troubleshooting Characteristics it may in fact be used only on a single specific programmable controller. This isolation is achieved by means of software or hardware keys that come with each copy of the software purchased.

Operational aids include a variety of resources that range from colour graphics CRTs to equipment or support programs that can give the operator specific access to processor parameters. In this situation the operator is usually allowed to read and modify timer, counter, and loop parameters but not have access to the program itself. Some aids facilitate the interaction between the programmable controller and dumb terminals, such as printers, to deliver process information in a desired format. Some devices have the ability to set up an entire panel and plug into the PLC through external RS 232C ports, thereby saving enormous panel and wiring costs.

The I/O enhancement group is a large category of PLC peripheral equipment. It includes all types of modules, from dry contact modules to intelligent I/O to remote I/O capabilities. Some I/O simulators used to develop and debug programs can be categorized in the I/O enhancement group. These specific devices are typically hardware modules that can be plugged into the PLC [1].

The computer interface device group is a rapidly expanding section of programmable controller peripheral devices. These devices allow peer-to-peer communications (i.e., one programmable controller connected directly to another), as well as network

interaction with various computer systems. In fact, this group of devices will certainly expand in number as communication standards become commonly accepted and more and more products are provided to facilitate such network interactions.

### **2.1.8 Differences between computers and PLCS**

Plus are often thought of as computers. To a certain extent this is true; however, there are four important differences between Plus and computers.

Maintenance and Troubleshooting
Programming Languages and Techniques
Environmental Considerations
Real-Time Operation/Orientation

## **2.2 RTU**

RTU is a microprocessor-controlled electronic device that interfaces objects in the physical world to a distributed control system or SCADA system by transmitting telemetry data to a master system, and by using messages from the master supervisory system to control connected objects. [1] Other terms that may be used for RTU is remote telemetry unit or remote Tele control unit.

### **2.2.1. RTU ARCHITECTURE**

An RTU monitors the field digital and analogue parameters and transmits data to the Central Monitoring Station. It contains setup software to connect data input streams to data output streams, define communication protocols, and troubleshoot installation problems. An RTU may consist of one complex circuit card consisting of various sections needed to do a custom fitted function or may consist of many circuit cards including CPU or processing with communications interface(s), and one or more of the following: (AI) analog input, (DI) digital (status) input, (DO/CO) digital (or control relay) output, or (AO) analog output card(s).

An RTU might even be a small process control unit with a small Data Base for PID, Alarming, Filtering, Trending functions and so on complemented with some BASIC (programming language) tasks, As it is used in pipeline, grid guarding systems.

### **2.2.2 Power supply**

A form of power supply will be included for operation from the AC mains for various CPU, status wetting voltages and other interface cards. This may consist of AC to DC converters where operated from a station battery system.

RTUs may include a battery and charger circuitry to continue operation in event of AC power failure for critical applications where a station battery is not available.

### **2.2.3 Digital (status) inputs**

Most RTUs incorporate an input section or input status cards to acquire two state real world information. This is usually accomplished by using an isolated voltage or current source to sense the position of a remote contact (open or closed) at the RTU site. This contact position may represent many different devices, including electrical breakers, liquid valve positions, alarm conditions, and mechanical positions of devices. Counter inputs are optional.

### **2.2.4 Analog inputs**

A RTU can monitor analog inputs of different types including 0-1 mA, 4–20 mA current loop, 0–10 V.,  $\pm 2.5$  V,  $\pm 5.0$  V etc. Many RTU inputs buffer larger quantities via transducers to convert and isolate real world quantities from sensitive RTU input levels. An RTU can also receive analog data via a communication system from a master or IED (intelligent electronic device) sending data values to it. The RTU or host system translates and scales this raw data into the appropriate units such as quantity of water left, temperature degrees, or Megawatts, before presenting the data to the user via the human–machine interface.

### **2.2.5 Digital (control relay) outputs**

RTUs may drive high current capacity relays to a digital output (or "DO") board to switch power on and off to devices in the field. The DO board switches voltage to the coil in the relay, which closes the high current contacts, which completes the power circuit to the device. RTU outputs may also consist of driving a sensitive logic input on an electronic PLC, or other electronic device using a sensitive 5 V input.

### **2.2.6 Analogue outputs**

While not as commonly used, analogue outputs may be included to control devices that require varying quantities, such as graphic recording instruments (strip charts). Summed or processed data quantities may be generated in a master SCADA system and output for display locally or remotely, wherever needed.

### **2.2.7 Software and logic control**

Modern RTUs are usually capable of executing simple programs autonomously without involving the host computers of the DCS or SCADA system to simplify deployment and to provide redundancy for safety reasons. An RTU in a modern water management system will typically have code to modify its behaviour when physical override switches on the RTU are toggled during maintenance by maintenance personnel. This is done for safety reasons; a miscommunication between the system operators and the maintenance personnel could cause system operators to mistakenly enable power to a water pump when it is being replaced, for example.

Maintenance personnel should have any equipment they are working on disconnected from power and locked to prevent damage and/or injury.

### **2.2.8 Communications**

A RTU may be interfaced to multiple master stations and IEDs (Intelligent Electronic Device) with different communication media (usually serial (RS232, RS485, RS422) or Ethernet). An RTU may support standard protocols (Mod bus, IEC 60870-5-101/103/104, DNP3, IEC 60870-6-ICCP, IEC 61850 etc.) to interface any third party

software. Data transfer may be initiated from either end using various techniques to insure synchronization with minimal data traffic. The master may poll its subordinate unit (Master to RTU or the RTU poll an IED) for changes of data on a periodic basis. Analog value changes will usually only be reported only on changes outside a set limit from the last transmitted value. Digital (status) values observe a similar technique and only transmit groups (bytes) when one included point (bit) changes. Another method used is where a subordinate unit initiates an update of data upon a predetermined change in analogue or digital data. Periodic complete data transmission must be used periodically, with either method, to insure full synchronization and eliminate stale data. Most communication protocols support both methods, programmable by the installer. Multiple RTUs or multiple IEDs may share a communications line, in a multi-drop scheme, as units are addressed uniquely and only respond to their own polls and commands.

### **2-8-1 IED communications**

IED communications transfer data between the RTU and an IED. This can eliminate the need for many hardware status inputs, analogue inputs, and relay outputs in the RTU. Communications are accomplished by copper or fibre optics lines. Multiple units may share communication lines.

### **2-8-2 Master communications**

Master communications are usually to a larger control system in a control room or a data collection system incorporated into a larger system. Data may be moved using a copper, fibre optic or radio frequency communication system. Multiple units may share communication lines.

## **2.9 Applications**

Remote monitoring of functions and instrumentation for:

- Environmental monitoring systems (pollution, air quality, emissions monitoring)
- Mine sites



- Air traffic equipment such as navigation aids (DVOR, DME, ILS and GP)

Remote monitoring and control of functions and instrumentation for:

- Hydro-graphic (water supply, reservoirs, sewage systems)
- Electrical power transmission networks and associated equipment
- Natural gas networks and associated equipment

## 2.3 DCS

DCS is a computerised control system for a process or plant usually with a large number of control loops, in which autonomous controllers are distributed throughout the system, but there is central operator supervisory control. This is in contrast to non-distributed control systems that use centralised controllers; either discrete controller located at a central control room or within a central computer. The DCS concept increases reliability and reduces installation costs by localising control functions near the process plant, with remote monitoring and supervision.

### 2.3.1 DCS Technical Points

#### 4-20 mA current loop control with "smart" control valve positioner

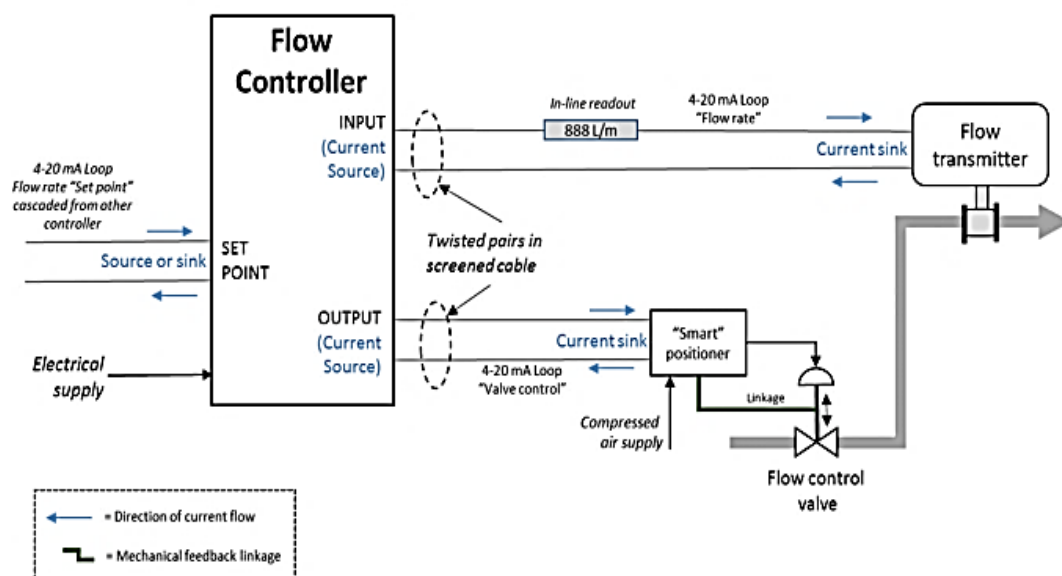

*Example of a continuous flow control loop. Signalling is by industry standard 4–20 mA current loops, and a "smart" valve positioned ensures the control valve operates correctly.*

The processor nodes and operator graphical displays are connected over proprietary or industry standard networks, and network reliability is increased by dual redundancy cabling over diverse routes. This distributed topology also reduces the amount of field cabling by siting the I/O modules and their associated processors close to the process plant. The processors receive information from input modules, process the information and decide control actions to be signalled by the output modules. The field inputs and outputs can be analog signals e.g. 4–20 mA DC current loop or 2 state signals that switch either "on" or "off", such as relay contacts or a semiconductor switch.

DCSs are connected to sensors and actuators and use set point control to control the flow of material through the plant. A typical application is a PID controller fed by a flow meter and using a control valve as the final control element. The DCS sends the set point required by the process to the controller which instructs a valve to operate so that the process reaches and stays at the desired set point. (See 4–20 mA schematic for example). Large oil refineries and chemical plants have several thousand I/O points and employ very large DCS. Processes are not limited to fluidic flow through pipes, however, and can also include things like paper machines and their associated quality controls, variable speed drives and motor control centres, cement kilns, mining operations, ore processing facilities, and many others.

DCSs in very high reliability applications can have dual redundant processors with "hot" switch over on fault, to enhance the reliability of the control system.

Although 4–20 mA has been the main field signalling standard, modern DCS systems can also support field bus digital protocols, such as Foundation Field bus, Profile bus, HART, Mod bus, PC Link etc., and other digital communication protocols such as Mod bus. Modern of DCSs also support neural networks and fuzzy logic applications. Recent research focuses on the synthesis of optimal distributed controllers, which optimizes a certain H-infinity or the H<sup>2</sup> control criterion.

## 2.3.2 DCS Communications

- Individual Controllers communicating to a central computers acting as workstations.
- Communication accomplished by digital data highways, multi drop system, several devices connected to the same network, daisy chain.
- The Database is the key, a well-defined coordinated articulate database, seamless between devices.
- Failure of a single component will not cause system failure, shutdown; sometimes called graceful degradation
- A hardware or software failure will not go undetected. Usually done with status bits, or logic.
- I/O – Input Output, electrical signals connected to the system
- Some systems use redundant I/O to increase reliability

## 2.3.3 DCS Hardware

Production Control Components most equipment found in industry can be divided into four key categories:

A. Process Control Equipment (Control/Automation Level) programmable devices which control processes. These include, industrial computers, PLCs, specialist controllers for robots, CNC machines etc.

B. Mechanical Components (Discrete Process Level), conveyor belts, linear/rotary axes controlled by Motors, automated guided vehicles

C. Actuators (Discrete Process Level) – these include electric motors, pneumatic valves, pistons, Maglev guides, and other similar devices which perform operations.

D. Sensors (Discrete Process Level) – these are used for obtaining measurements and data from the environment. For example, the position of mechanical components, testing the quality of products.

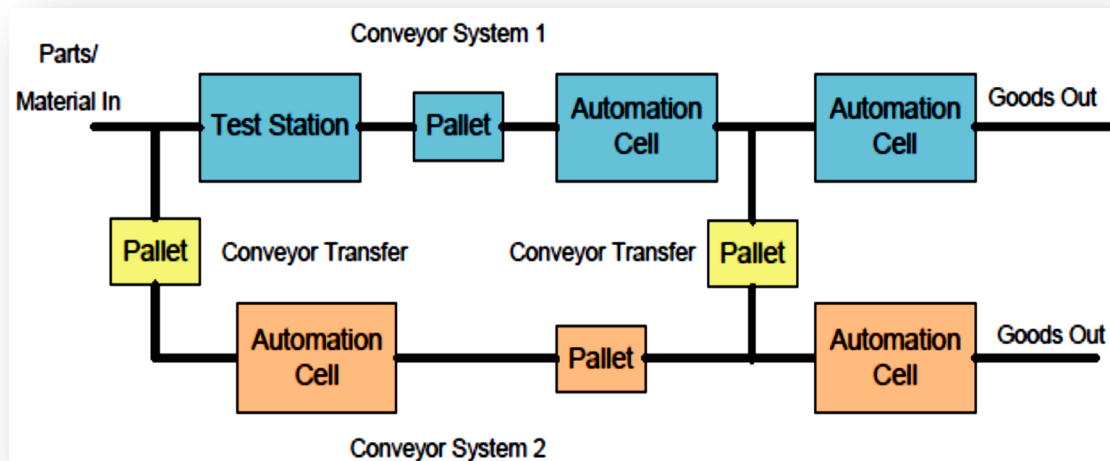

- Analogue input 12 bits 1 in 4069
- Analogue Output 10 bits 1 in 1024
- The I/O are wired in card files and racked in electrical cabinets, most often located in a shelter remote from the operator control room.
- Industrial grade can handle harsh environments, electrical noise transients, radio interference, etc.
- IEEE C37.90.1-1989 was called 472; defines an electrical test that standardizes these conditions.
- Electrical Grounding - usually "isolated" from the plant ground system, however it is connected at one point

### 2.3.4 DCS Reliability

- Reliability – very high, usually defined example 2 hardware failures or less per year.
- MTBF means time before failure 100 years
- MTTR means time to repair 1 hour or less.
- Online diagnostics; provides a report of the network traffic, communication errors, retries.
- Redundancy – will allow some or all components in the system to be redundant. Provides status and alarming for failures.

### **2.3.5 DCS Alarm management**

- Alarms – DCS have sophisticated alarming conventions
- Alarm Hi, HiHi, Lo, LoLo, etc, as well as rate of change.
- Alarms should have dead band to prevent chatter, on and off at the same point due to noise.
- Configured in a priority manor with different sounds colored schemes
- Can be suppressed, example during a start-up, shutdown sequence.
- Acknowledge in the console display where the variable is configured, forces the operator to pay attention to the variable's operation
- Alarm history file can be analysed by an off line software program to sort by various attributes.

### **2.3.6 DCS technical accessories**

The DCS contains some of the following:

- A Control Network; linking the components on the network. Can have separate network for field devices and centralized processor as well as a network for the workstations, PCs Workstations, usually a PC used for real time optimization programs executed there. Route data, configure system
- Real Time Clock; all devices within the system have coordinated and synchronized with a global position sensor.
- Operator Stations, usually a PC for operator interface, can print, log alarms, and generate reports.
- Engineering Workstation PC used to develop control strategy design or configure the system.
- RCU used to communicate with remote units, multiplexers, data concentrators, wireless.
- Application Stations PC run databases, spread sheet interface, simulations. Uses OPC as a data link to the DCS database.

- Mass Storage Device, Archiving data; Data compression algorithms allow archiving large data sets.
- Inter nodal communications DCS system architecture allows data transfer to Manufacturing databases
- Summary – a DCS is more than just a collection of controllers and a way to operate them, it is a system designed to interface with the overall manufacturing environment.

### **2.3.7 DCS Operator station**

- Consoles or HMI computer consoles or workstations are used for operator entry. Special work surfaces are architecturally designed to accommodate telephone, paging in addition to the keyboard and mouse, usually a track ball design.
- Consoles frequently incorporate dual monitors, printers for plots and reports.

### **2.3.8 Typical application**

DCS are dedicated systems used in manufacturing processes that are continuous or batch-oriented. Processes where a DCS might be used include:

- Chemical plants
- Petrochemical (oil) and refineries
- Environmental control systems

## **2.4 SCADA**

**SCADA** is a control system architecture that uses computers, networked data communications and graphical user interfaces for high-level process supervisory management, but uses other peripheral devices such as programmable logic controllers and discrete PID controllers to interface to the process plant or machinery. The operator interfaces which enable monitoring and the issuing of process commands, such as controller set point changes, are handled through the SCADA computer system. However, the real-time control logic or controller calculations are performed by networked modules which connect to the field sensors and actuators.

The SCADA concept was developed as a universal means of remote access to a variety of local control modules, which could be from different manufacturers allowing access through standard automation protocols. In practice, large SCADA systems have grown to become very similar to distributed control systems in function, but using multiple means of interfacing with the plant. They can control large-scale processes that can include multiple sites, and work over large distances as well as small distance. It is one of the most commonly-used types of industrial control systems, however there are concerns about SCADA systems being vulnerable to cyber-warfare/cyber-terrorism attacks.[3], [4],[10],[12],[13].

### 2.4.1. THE SCADA Concept in control operations

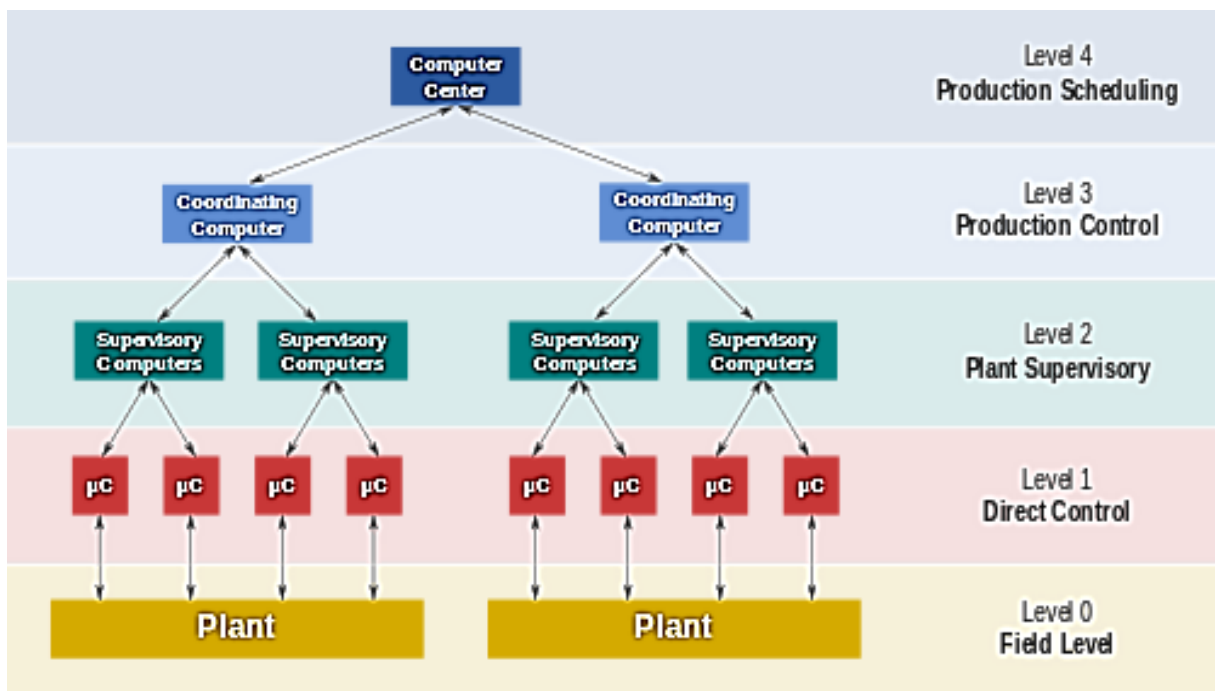

Figure.4.1: SCADA Level diagram

Functional levels of a manufacturing control operation; the key attribute of a SCADA system is its ability to perform a supervisory operation over a variety of other proprietary devices. The accompanying diagram is a general model which shows functional manufacturing levels using computerised control. Referring to the diagram in figure.4.1:

- Level 0 contains the field devices such as flow and temperature sensors, and final control elements, such as control valves.

- Level 1 contains the industrialised input/output (I/O) modules, and their associated distributed electronic processors.
- Level 2 contains the supervisory computers, which collate information from processor nodes on the system, and provide the operator control screens.
- Level 3 is the production control level, which does not directly control the process, but is concerned with monitoring production and targets.
- Level 4 is the production scheduling level.

Level 1 contains the (PLCs) or (RTUs). And level 2 contains the SCADA software and computing platform. The SCADA software exists only at this supervisory level as control actions are performed automatically by RTUs or PLCs. SCADA control functions are usually restricted to basic overriding or supervisory level intervention. For example, a PLC may control the flow of cooling water through part of an industrial process to a set point level, but the SCADA system software will allow operators to change the set points for the flow. The SCADA also enables alarm conditions, such as loss of flow or high temperature, to be displayed and recorded. A feedback control loop is directly controlled by the RTU or PLC, but the SCADA software monitors the overall performance of the loop.

Levels 3 and 4 are not strictly process control in the traditional sense, but are where production control and scheduling takes place.

Data acquisition begins at the RTU or PLC level and includes instrumentation readings and equipment status reports that are communicated to level 2 SCADA as required. Data is then compiled and formatted in such a way that a control room operator using the HMI (Human Machine Interface) can make supervisory decisions to adjust or override normal RTU (PLC) controls. Data may also be fed to a historian, often built on a commodity database management system, to allow trending and other analytical auditing.

SCADA systems typically use a tag database, which contains data elements called tags or points, which relate to specific instrumentation or actuators within the process



system according to such as the Piping and instrumentation diagram. Data is accumulated against these unique process control equipment tag references.

## **2.4.2 SCADA System components**

Typical SCADA mimic. For process plant, these are based upon the piping and instrumentation diagram. A SCADA system usually consists of the following main elements:

### **2.4.2.1 Supervisory computers**

This is the core of the SCADA system, gathering data on the process and sending control commands to the field connected devices. It refers to the computer and software responsible for communicating with the field connection controllers, which are RTUs and PLCs, and includes the HMI software running on operator workstations. In smaller SCADA systems, the supervisory computer may be composed of a single PC, in which case the HMI is a part of this computer. In larger SCADA systems, the master station may include several HMIs hosted on client computers, multiple servers for data acquisition, distributed software applications, and disaster recovery sites. To increase the integrity of the system the multiple servers will often be configured in a dual-redundant or hot-standby formation providing continuous control and monitoring in the event of a server malfunction or breakdown.

### **2.4.2.2 RTU**

RTUs connect to sensors and actuators in the process, and are networked to the supervisory computer system. RTUs are "intelligent I/O" and often have embedded control capabilities such as ladder logic in order to accomplish Boolean logic operations.

### **2.4.2.3 PLC**

The PLCs are connected to sensors and actuators in the process, and are networked to the supervisory system in the same way as RTUs. PLCs have more sophisticated embedded control capabilities than RTUs, and are programmed in one or more IEC

61131-3 programming languages. PLCs are often used in place of RTUs as field devices because they are more economical, versatile, flexible and configurable.

#### **2.4.2.4 Communication infrastructures**

This connects the supervisory computer system to the RTUs and PLCs, and may use industry standard or manufacturer proprietary protocols. Both RTUs and PLCs operate autonomously on the near-real time control of the process, using the last command given from the supervisory system. Failure of the communications network does not necessarily stop the plant process controls, and on resumption of communications, the operator can continue with monitoring and control. Some critical systems will have dual redundant data highways, often cabled via diverse routes.

#### **2.4.3 Communication infrastructure and methods**

SCADA systems have traditionally used combinations of radio and direct wired connections, although SONET/SDH is also frequently used for large systems such as railways and power stations. The remote management or monitoring function of a SCADA system is often referred to as telemetry. Some users want SCADA data to travel over their pre-established corporate networks or to share the network with other applications. The legacy of the early low-bandwidth protocols remains, though.

SCADA protocols are designed to be very compact. Many are designed to send information only when the master station polls the RTU. Typical legacy SCADA protocols include Mod bus RTU, RP-570, Profile bus and connately. These communication protocols, with the exception of Mod bus (Mod bus has been made open by Schneider Electric), are all SCADA-vendor specific but are widely adopted and used. Standard protocols are IEC 60870-5-101 or 104, IEC 61850 and DNP3. These communication protocols are standardized and recognized by all major SCADA vendors. Many of these protocols now contain extensions to operate over TCP/IP. Although the use of conventional networking specifications, such as TCP/IP, blurs the line between traditional and industrial networking, they each fulfil fundamentally differing requirements. Network simulation can be used in conjunction

with SCADA simulators to perform various 'what-if' analyses. With increasing security demands (such as North American Electric Reliability Corporation (NERC) and critical infrastructure protection (CIP) in the US, there is increasing use of satellite-based communication. This has the key advantages that the infrastructure can be self-contained (not using circuits from the public telephone system), can have built-in encryption, and can be engineered to the availability and reliability required by the SCADA system operator. Earlier experiences using consumer-grade VSAT were poor. Modern carrier-class systems provide the quality of service required for SCADA. [4]

RTUs and other automatic controller devices were developed before the advent of industry wide standards for interoperability. The result is that developers and their management created a multitude of control protocols. Among the larger vendors, there was also the incentive to create their own protocol to "lock in" their customer base. A list of automation protocols is compiled here.

OLE for process control Open Platform Communications (OPC) can connect different hardware and software, allowing communication even between devices originally not intended to be part of an industrial network.[1], [4]

# CHAPTER THREE

## CRUDE OIL PUMP STATION

### COMPONENTS

#### 3.1 Back ground

The Pumping Facilities comprises of six(6) numbers of pumping stations [Number of pump stations = total system head / MAOH (MAOH = Maximum Allowable Operating Head)] (for the initial stage) located along the 1,370km pipeline from the starting point in Palogue and ended at Marine Terminal located in Port Sudan via a 32-inch diameter steel pipeline. Upon completion of the Melut Basin Development, the pumping facilities will consist of approximately (11 Pumping Stations) with heating facilities located along the pipeline to transport crude oil at 500,000 bpd of ultimate capacity. Initially, six (6) suggest Pumping Station (PS) with heating system have been installed to cater for the initial flow of 200,000 bpd of crude oil with provision for future expansion to 500,000 bpd. The Pumping Stations is designed complete with all necessary items and associated utility and auxiliary equipment systems that are required to provide a safe and fully operational system. Pumping Station no. 1 is located in Palogue immediately downstream of Palogue Field Production Facility (FPF). Pumping Station no. 2 is located in Al-Jabalayn immediately downstream of Al-Jabalayn Central Production Facility (CPF). Utilities such as power, water (utility and potable), air (instrument and utility) and diesel fuel supply are coming from FPF, CPF and power plant at Palogue and Jabalyn respectively.

PS3 to PS6 is designed with self-sufficient in all utilities and operational support including accommodation see figure.3-1 PDOC pump stations. Main equipments installed at each pump stations (PS) are as follows:

- Pipeline main pump (Centrifugal pumps) driven by dual fuel (diesel/crude) burning engine. 3 numbers in parallel with operating philosophy of (2 running and 1 standby), installed at each PS.

- Each of centrifugal pumps is capable to deliver up to 165,000 Bopd flow rate. With 2 pumps running, the pump station can deliver up to 310,000 Bopd flow rate to the pipeline system during the initial stage. The centrifugal pump is driven by direct coupled via increased speed gear box of 6:1 ratio. The engine is dual fuel diesel/crude burning type and capable of variable speed.
- Electrical driven screw pumps for yo-yo operation. (2 numbers) in parallel with operating philosophy of (1 running and 1 standby) or (2 units) running simultaneously, installed at each PS.
- Pump stations require installation of two electrically driven positive displacement pumps (screw pumps) used for low flow “Yo-Yo” action and for initial start of a gelled pipeline.
- 850 kW generator set unit driven by dual fuel (diesel/crude) burning engine. (3 numbers) in parallel with operating philosophy of (2 running and 1 standby). Installed at PS3 to PS6.
- A manual start 850kW emergency generator is installed at each PS to provide minimum power requirement for start-up of manual 850 kW generators.
- 1 MW generator set unit driven by diesel engine as emergency generator installed at PS1 and PS2. Only (1 unit) for each station.
- Shell and tube heat exchanger. (3 numbers) in parallel with operating philosophy of (2 running and 1 standby), installed at PS3 to PS6.
- Hot Oil Heater burner system. 2 numbers in parallel with operating philosophy of (1 running and 1 standby), installed at PS3 to PS6.
- Station inlet filters. (2 numbers) in parallel with operating philosophy of (1 running and 1 standby), installed at each PS.
- Diesel and crude fuel storage tanks for PS3 to PS6. Crude fuel storage tank is designed to accommodate surge relief volume. As for PS1 and PS2 a dedicated surge relief tank is built for the surge relief system.
- Open and closed drain system, installed at each PS.
- Storage water tank and water treatment facilities, installed at PS3 to PS6.

- Instrument and Utility air system.
- Dedicated crude treatment facilities for the pump drivers, installed at each PS.
- Dedicated crude treatment facilities for generator set drivers, installed at PS3 to PS6.
- Electrical heat tracing system, installed at PS3 to PS6.
- Surge Relief System (which currently the scope of work is disputed by the CONTRACTOR).
- Control building to house the Station Control and Emergency Shutdown system, MCC, and PLC for field equipment

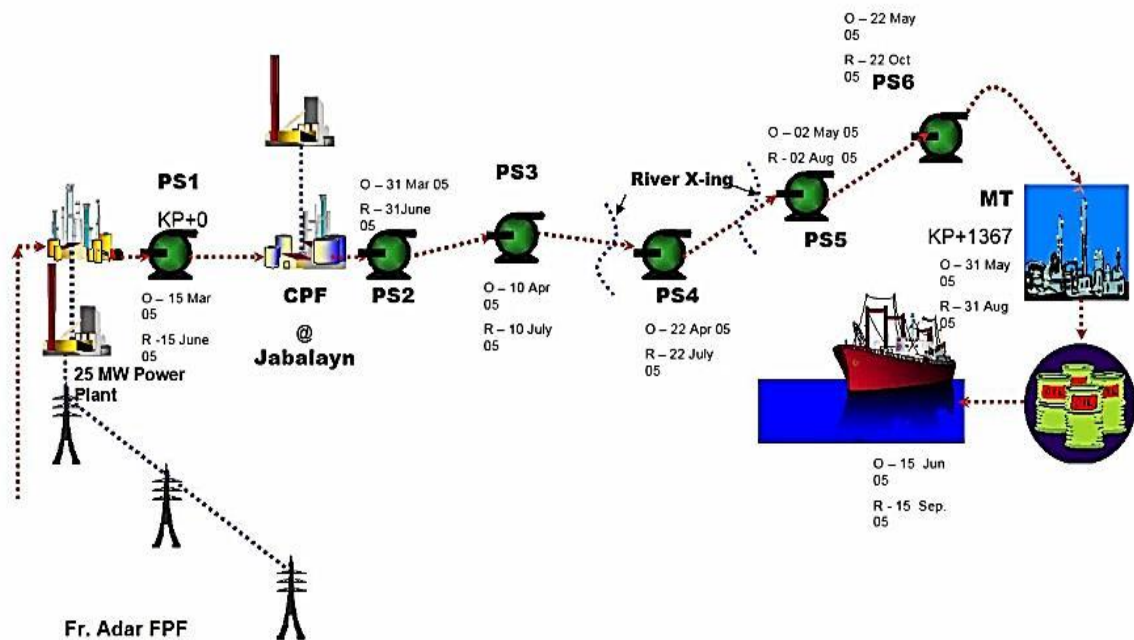

Figure 3.1: PDOC Pump Station

## 3.2. Pumps

### 3.2.1 Classification of pumps

Pumps may be classified on the basis of the applications they serve, the materials from which they are constructed, the liquids they handle, and even their orientation in space. All such classifications, however, are limited in scope and tend to substantially overlap each other. A more basic system of classification, the one used in this handbook, first defines the principle by which energy is added to the fluid, goes on to identify the means by which this principle is implemented, and

finally delineates specific geometries commonly employed. This system is therefore related to the pump itself and is unrelated to any consideration external to the pump or even to the materials from which it may be constructed. Under this system, all pumps may be divided into two major categories: (1) dynamic, in which energy is continuously added to increase the fluid velocities within the machine to values greater than those occurring at the discharge so subsequent velocity reduction within or beyond the pump produces a pressure increase, and (2) displacement, in which energy is periodically added by application of force to one or more movable boundaries of any desired number of enclosed, fluid-containing volumes, resulting in a direct increase in pressure up to the value required to move the fluid through valves or ports into the discharge line. Dynamic pumps may be further subdivided into several varieties of centrifugal and other special-effect pumps. Figure 3.2 presents in outline form a summary of the significant classifications and sub-classifications within this category. Displacement pumps are essentially divided into reciprocating and rotary types, depending on the nature of movement of the pressure-producing members. Each of these major classifications may be further subdivided into several specific types of commercial importance, as indicated in Figure 3.2.

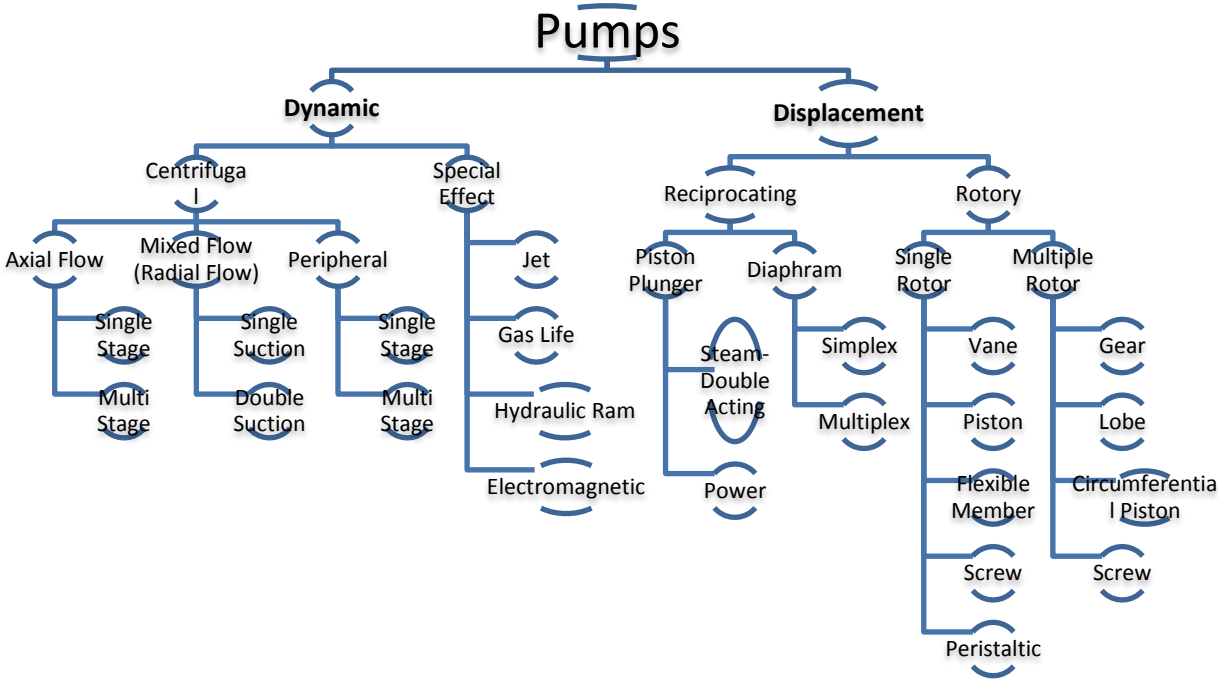

**Figure 3.2:** classification of dynamic & displacement pumps

### 3.2.2 Centrifugal Pumps

A centrifugal pump is a rotating machine in which flow and pressure are generated dynamically. The inlet is not walled off from the outlet as is the case with positive displacement pumps, whether they are reciprocating or rotary in configuration. Rather, a centrifugal pump delivers useful energy to the fluid or “pumpage” largely through velocity changes that occur as this fluid flows through the impeller and the associated fixed passageways of the pump; that is, it is a “rotodynamic” pump. All impeller pumps are rotodynamic, including those with radial-flow, mixed-flow, and axial-flow impellers: the term “centrifugal pump” tends to encompass all rotodynamic pumps. Although the actual flow patterns within a centrifugal pump are three-dimensional and unsteady in varying degrees, it is fairly easy, on a one-dimensional, steady-flow basis, to make the connection between the basic energy transfer and performance relationships and the geometry or what is commonly termed the “hydraulic design” (more properly the “fluid dynamical design”) of impellers and stators or stationary passageways of these machines. In fact, disciplined one-dimensional thinking and analysis enables one to deduce pump operational characteristics (for example, power and head versus flow rate) at both the optimum or design conditions and off-design conditions. This enables the designer and the user to judge whether a pump and the fluid system in which it is installed will operate smoothly or with instabilities. The user should then be able to understand the offerings of a pump manufacturer, and the designer should be able to provide a machine that optimally fits the user’s requirements.

- The complexities of the flow in a centrifugal pump command attention when the energy level or power input for a given size becomes relatively large. Fluid phenomena such as recirculation, cavitation, and pressure pulsations become important; “hydraulic” and mechanical interactions-involving stress, vibration, rotor dynamics, and the associated design approaches, as well as the materials used-become critical; and operational limits must be understood and respected.



- Type of rotodynamic pump to be used depends on the relative values of capacity and head

Low capacity and high	centri
high capacity and low	axial
medium condition	mixe

- Capacity, head and rotational speed are the constituents of the specific speed expression
- The specific speed indicates best pump for the required capacity, head and speed.

### 3.2.3 Screw pumps

Screw pumps are a special type of rotary positive displacement pump in which the flow through the pumping elements is truly axial. The liquid is carried between screw threads on one or more rotors and is displaced axially as the screws rotate and mesh (see Figure 2). In all other rotary pumps, the liquid is forced to travel circumferentially, thus giving the screw pump with its unique axial flow pattern and low internal velocities a number of advantages in many applications where liquid agitation or churning is objectionable. The applications of screw pumps cover a diversified range of markets including navy, marine, and utilities fuel oil services; marine cargo; industrial oil burners; lubricating oil services; chemical processes; petroleum and crude oil industries; power hydraulics for navy and machine tools; and many others. The screw pump can handle liquids in a range of viscosities, from molasses to gasoline, as well as synthetic liquids in a pressure range from 50 to 5000 lb/in<sup>2</sup> (3.5 to 350 bar) and flows up to 8000 gal/min (1820 m<sup>3</sup>/h). Because of the relatively low inertia of their rotating parts, screw pumps are capable of operating at higher speeds than other rotary or reciprocating pumps of comparable displacement. Some turbine-attached lubricating oil pumps operate at 10,000 rpm and even higher. Screw pumps, like other rotary positive displacement pumps, are self-priming and have a delivery flow

characteristic, which is essentially independent of pressure, provided there is sufficient viscosity in the liquid being pumped. Screw pumps are generally classified into single- or multiple-rotor types. The latter is further divided into timed and untimed categories. The single-screw or progressive cavity pump has a rotor thread that is eccentric to the axis of rotation and meshes with internal threads of the stator (rotor housing or body). Alternatively, the stator is made to wobble along the pump center line. Multiple-screw pumps are available in a variety of configurations and designs. All employ one driven rotor in a mesh and one or more sealing rotors. Several manufacturers have two basic configurations available: single-end and double-end construction, of which the latter is the better known. Screw pumps are emergency pumps and they don't operate in normal conditions; and are driven electrically. Mainly they are used for shut down conditions, because they have the ability to generate high head to break the gel that might occur during the shutdown.

### **3.3 Engine's driver (mechanical power):**

It is quite rare that pumps are required to operate at one single point of its characteristic curve. The working speed of a pump is determined by the driver, being a diesel engine or an electric motor.

- Variable speed drives allows pumps to operate at exactly the speed required for the pump duty, without the need for throttling the system. Such flexibility has a favourable effect on the long term economics of the pumping system.
- Variable-speed driving for diesel-driven pumps the required speed variation is facilitated by adjustment of fuel supply to the engine. The higher is the fuel feed rate the higher is the engine speed, the higher is the pump's output, and vice versa. The unit controlling power level of the engine is known as the governor. There are two types of governors currently in use:
  - Mechanical governors.
  - Electronic governors.

- Variable frequency drives (VFD) use electronic components to change motor frequency and hence causes a change in motor and pump speed, as required.
- Frequency inverters are usually positioned in the control panel. The power cable to the motor had to be screened for electromagnetic compatibility.
- Integral frequency inverters are attached directly to the motor. Because of their proximity to the motor, screened cables are unnecessary. To a considerable extent, the devices must be resistant to heat, humidity and vibrations.
- Advantages of VFD:
  - Minimal maintenance
  - Flexible (continuous) operation
  - Energy efficient
  - Interface to data management.

The diesel engines are the drivers for the pumps; each pump is connected to a diesel engine and these engines running by using crude oil fuel small amount of crude is extracted from the flow and passed through the fuel system in order to be injected in the engines.

Normally the start up for the engine will be on diesel and then it will be transferred to crude oil, this will flush the injectors.

### **3.4 Generator (electrical power):**

- 850 kW generator set unit driven by dual fuel (diesel/crude) burning engine. (3 Numbers) in parallel with operating philosophy of (2 running and 1 standby).
- A manual start 80kW emergency generator is installed at each PS to provide minimum power requirement for start-up of manual 850 kW generators. And 1 MW generator set unit driven by diesel engine as emergency generator installed at PS1 and PS2.

- The main purpose for the gensets is to generate the electricity which it need to operate:
  - Control room.
  - Other small instruments.
  - Lighting.
  - Screw pumps.
  - Facilities.

### **3.5 Control room:**

In physical appearance the control equipment used in DCS systems is similar to modern office equipment .CRT-based consoles, keyboards, printers and personal computers are some of the basic high visibility components in this control centers. The main functions of the control room are:

- To control the whole pump station.
- To record all the measurements for the pump station.
- To supervise all the basic maintenance works in the pump station.
- To communicate with Main Control Center. And the function of the MCC:
  - To control the whole pipe line operations in the high level, and to enable secondary control level in case of failures.
  - To record the data all over the pipeline and the involved facilities.
  - SCADA system (Supervisory Control & Data Acquisition.) is used for the control along the pipeline.

### **3.6 Heating Stations**

The sum of unintentional heat gains often entirely offsets building heat losses due to transmission through the structure and infiltration of colder outside air. Any remaining net heat loss must be made up by additional heat supplied to the space. In cold climates, building insulation and double glazing can be used to minimize structure heat losses and reduce condensation. Heat gain in pumping stations usually exceeds their heat loss in moderate weather. The excess heat must be removed by ventilating

with cooler outdoor air; if the ambient air temperature is too high, it must be removed by (1) direct evaporative cooling, (2) indirect evaporative cooling, or (3) refrigeration. Direct evaporative cooling is generally ineffective if the relative humidity of outdoor air exceeds about 75%. Even then, the nearly saturated air supply may promote rusting. Spaces with either high heat gains or a noise level that must be contained may justify the higher costs of refrigerated cooling or the use of some of the pumped water as the heat transfer medium in an air cooling system. The function of the heating station is to raise the temperature to the desired temperature to avoid gelling. There are three basic heating techniques:

- Space heaters (gas, oil, or electric) with a thermostat and a summer fan-only switch. Heater locations and airflow patterns should be chosen to produce thorough circulation through the space. In milder climates this may be the simplest solution. A separate fresh-air heater may also be provided. This approach has the least temperature control, but usually the stations do not require precise temperature control.
- Infrared radiant heating. With either gas or electricity, this is a simple and effective way of heating large, spacious working areas. Comfort conditions are achieved at a lower air temperature with radiant heat than with any other heating method.
- Ducted systems with temperature controls. Mixing dampers can be used to control the proportion of outdoor air to recirculate air in response to room temperature. A supply-air low limit control is recommended. Building heat loss in cold climates should be minimized by using wall and roof insulation, double glazing, and air dampers properly installed with blade and jamb seals to limit unwanted air infiltration. Follow a locally adopted energy conservation code or ASHRAE Standard 90-80. Maintain adequate space temperatures to facilitate essential activities and prevent freezing. Install a manual-reset, capillary-type low-temperature thermostat downstream from the preheating or heating coils

and set it at 30C (370F) to stop the fan and energize a remote warning for 100% outside air units in unattended standard. The pipe line system in PDOC used for heating two types:

- Heat exchanger (Electric heat exchangers to heat fluids (liquid or gas) with pressures ranging from 2 to 300 bars. Used in cases high differences in inlet and outlet temperature and for installations that require a high power input with limited spaces).
- Electric heaters (Armoured electric heaters welded on the flange, used in a wide range of industrial heating processes. Start-up and commissioning services are available on request).

### **3.7 Air Compressors**

The purpose of an air compressor is to provide a continuous supply of pressurized air. Three types of compressors; reciprocating, rotary and centrifugal air compressors. These types are defined by:

- method of cooling (air, water, oil)
- drive method (motor, engine, steam, other)
- how they are lubricated (oil, oil-free)
- packaged or custom-built

In addition to the air compressor package that includes the drive, air end, and cooling system.

The complete air systems contained of (as it shown in figure 3.3):

- Receiver Tanks
- Air Dryers
- Filters
- Piping Distribution

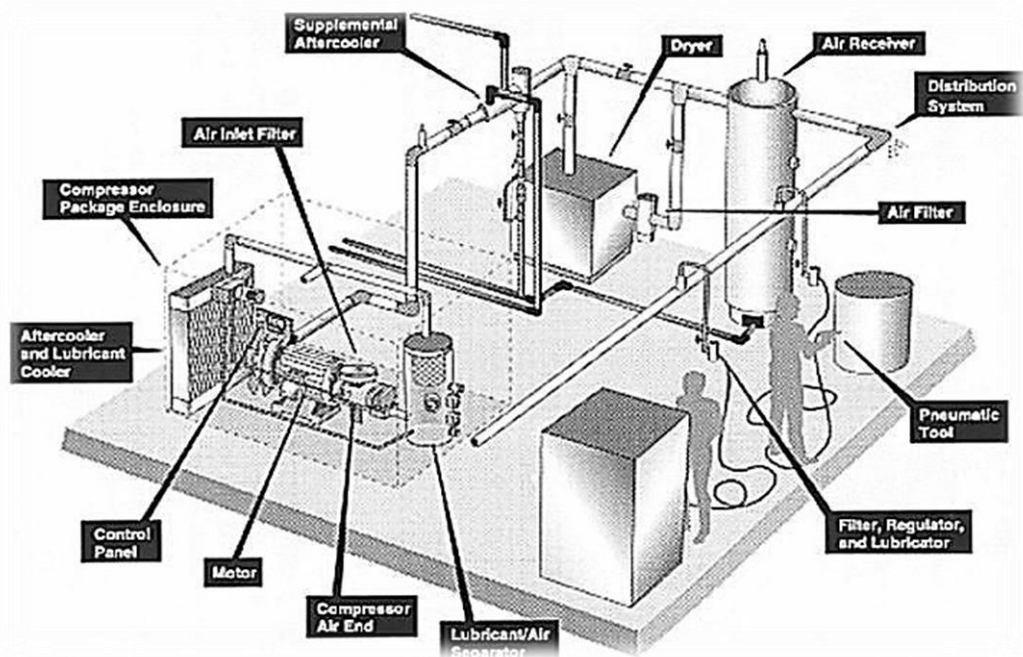

**Figure 3.3:** Air station system

- The single-stage reciprocating compressor has a piston that moves downward during the suction stroke, expanding the air in the cylinder. The expanding air causes pressure in the cylinder to drop. When the pressure falls below the pressure on the other side of the inlet valve, the valve opens and allows air in until the pressure equalizes across the inlet valve.
- The piston bottoms out and then begins a compression stroke. The upward movement of the piston compresses the air in the cylinder, causing the pressure across the inlet valve to equalize and the inlet valve to reseal.
- The piston continues to compress air during the remainder of the upward stroke until the cylinder pressure is great enough to open the discharge valve against the valve spring pressure. Once the discharge valve is open, the air compressed in the cylinder is discharged until the piston completes the stroke.
- The reciprocating air compressor is:
  - Single acting when the compressing is accomplished using only one side of the piston.
  - Double acting when using both sides of the piston.

- The reciprocating air compressor uses a number of automatic spring loaded valves in each cylinder that open only when the proper differential pressure exists across the valve
  - Inlet valves open when the pressure in the cylinder is slightly below the intake pressure.
  - Discharge valves open when the pressure in the cylinder is slightly above the discharge pressure.
- A compressor is considered to be:
  - Single stage when the entire compression is accomplished with a single cylinder or a group of cylinders in parallel.
  - Multi-stage units in which two or more steps of compression are grouped in series.
- Many applications involve conditions beyond the practical capability of a single compression stage. Too great a compression ratio (absolute discharge pressure/absolute intake pressure) may cause excessive discharge temperature or other design problems. The air is normally cooled between the stages to reduce the temperature and volume entering the following stage

### 3.8 Bypass system:

This is the emergency system used in case of major abort halt happened to isolate it from the pipeline.

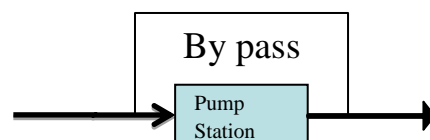

### 3.9 Block valves:

It works as isolation valves. Generally they are used to stop the flow or isolate portion of the system until it is desirable to achieve flow downstream of the valves. The basic requirement is to offer minimum resistance to the flow in fully open position and to exhibit tight shut off Characteristics when fully closed; those valves are controlled from the main



control room/Center. In some cases the power supplied for those valves are generated from solar energy. When two block valves are closed, the section between them can be emptied of natural gas or natural gas liquids without having to empty the rest of the pipeline. They are used to isolate sections of the pipeline for maintenance, or in case of a known or suspected leak. Mainline block valve sites are gravelled and might be fenced. They may contain:

- below-ground block valves
- by-pass valves
- a system to vent natural gas into the atmosphere under controlled conditions, if required

- Features & Benefits
  - Contamination-free, radial-diaphragm technology
  - Block body design eliminates dead leg area
  - Clean, self-draining design
  - Simple assembly with standard clamp-no additional tools needed
  - Integral travel stops
  - Patented shoulder seal
  - Isolates process fluids absolutely
  - Easy to seal and inspect
  - Up to 80% reduction in maintenance costs
  - Reduced down-time when changing diaphragms
  - Never needs re-tightening or adjustment

### **3.10 Storage Tanks**

It is a limited capacity storage facility to run the operation in the pump station.

No of storage tanks - 6 (fitted by Radar Gauge System (dip + temp))

Tank Capacity - 500,000 bbls

Total Storage Capacity - 3,000,000 bbls

Total Dead-Stock - 300,000 bbls

Total Pump-able Capacity - 2,700,000 bbls

Total reference height	-	17.9 m
Safe fill height	-	16 m
Tank Roof Diameter	-	82 m

# **CHAPTER FOUR**

## **PUMP STATION SYSTEM**

### **IMPLEMENTATION**

#### **4.1 Tools requirement.**

**4.1.1 Software:** ABB freelance control builder 800F system Architecture

**4.1.2 Hardware:** Recommended PC system:

##### **A) For Control builder F:**

- Hard disk for installation: 500 MB free disk space
- Hard disk for operation: 10 GB free disk space
- Operating system: Microsoft Windows XP, Prof. SP2, 32
- Speed:  $\geq 2$  GHz
- RAM: 1 GB
- Ethernet card with support: Interface BNC/AUI/TP

##### **B) For DigiVis:**

- Hard disk for installation: 500 MB free disk space
- Hard disk for operation:  $\geq 2$  GB free disk space
- Recommended for archiving :  $\geq 80$  GB (depending on configuration)
- Operating system: Microsoft Windows XP Prof. SP2
- Speed:  $\geq 2$  GHz
- RAM: 1 GB
- Graphics card for dual monitor: AGP Matrox G550, ATI X300.
- Ethernet card with supp.: Interface BNC/AUI/TP

##### **C) For Field equipment & instrument Devices:**

- Pressure Transmitter & switch.
- Temperature Transmitter & switch.
- Level Transmitter & switch.
- Feed & booster pumps
- Storage tank
- Pneumatic valve

## 4.2 System implementation

The System implementation via ABB Automation control builder 800F software has a design sequence for controlling and monitoring are: design project, commissioning & interface the project via DigiVis program

### 4-2-1 Designing project



On control builder F program, the following steps used for designing; the most function block diagram (FBD) which is used in our implementation is briefed in library items as a favorite FBD see figure 4.1

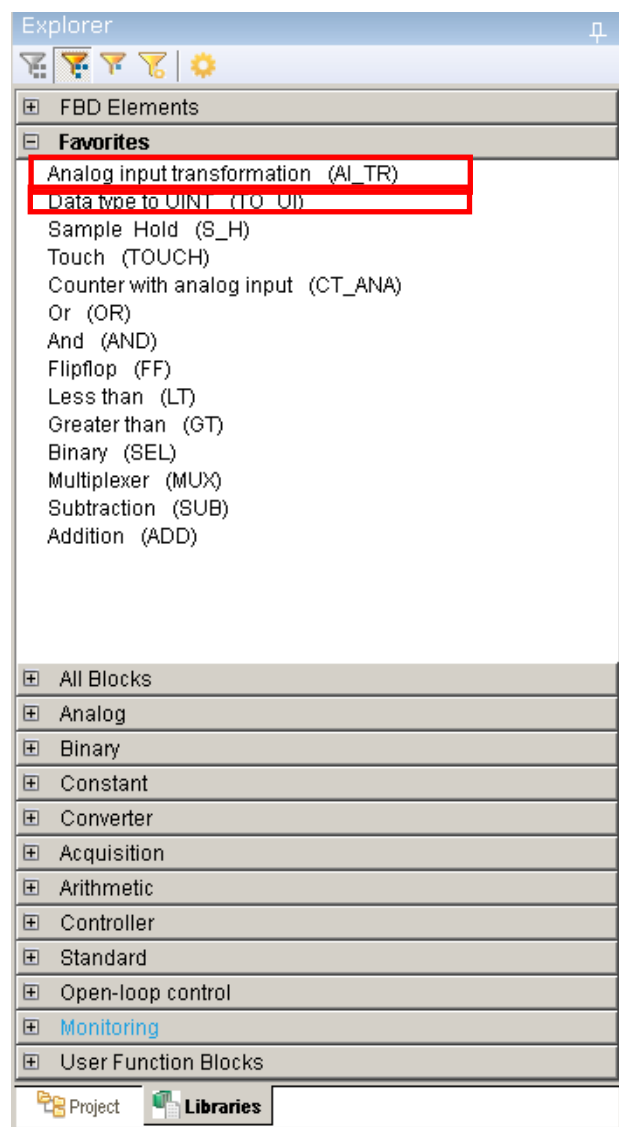

Figure 4.1 favourites' FBD items

- Designed the station equipments graphic by drawing and laying the equipments as required.
- After that some FBD items used for configuration the instrument field devices and mechanical equipments like:
  - Analogue input transformation (AI\_TR) & for conversion the signal from analogue to digital used the data type to UINT (TO\_UI) also used the counter with Analogue input (CT\_ANA) FBD for calculated the level percentage of storage tank see figures. 4.2 & 4.3.
  - For monitoring & processing used some logic gates [OR, AND], basic arithmetic's [addition (ADD), subtraction (SUB)], comparators [Greater Than (GT), less than (LT)], switches [Binary (SEL), flip flop (FF), multiplexer (MUX)] for controlling the level switch of storage tank (LALL & LAHH).
  - For equipments controlling used the breakers like touch button (TOUCH), sample hold (S\_H) for controlling the booster pump by selecting (Auto/Manual) mode and (start/Stop). See figures.4.2, 4.4 & 4.5.

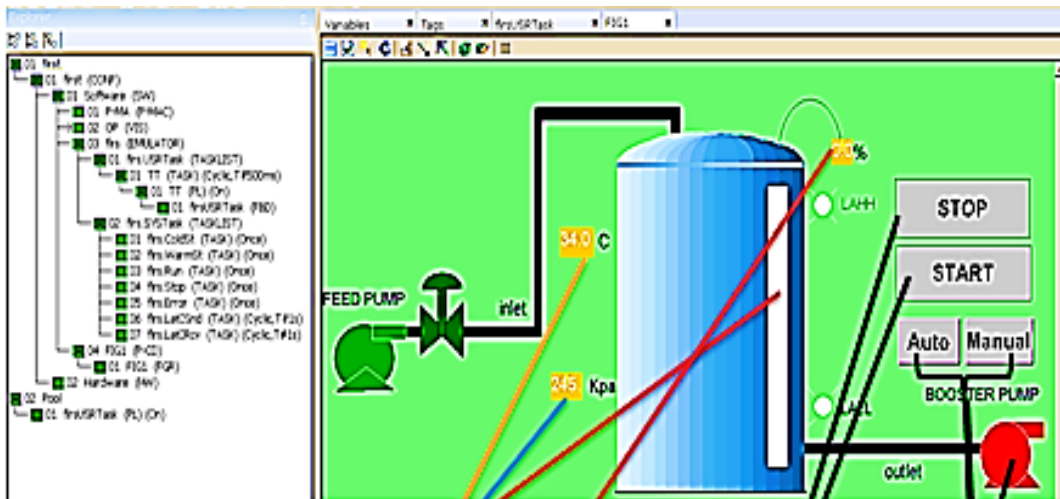

Figure.4-2

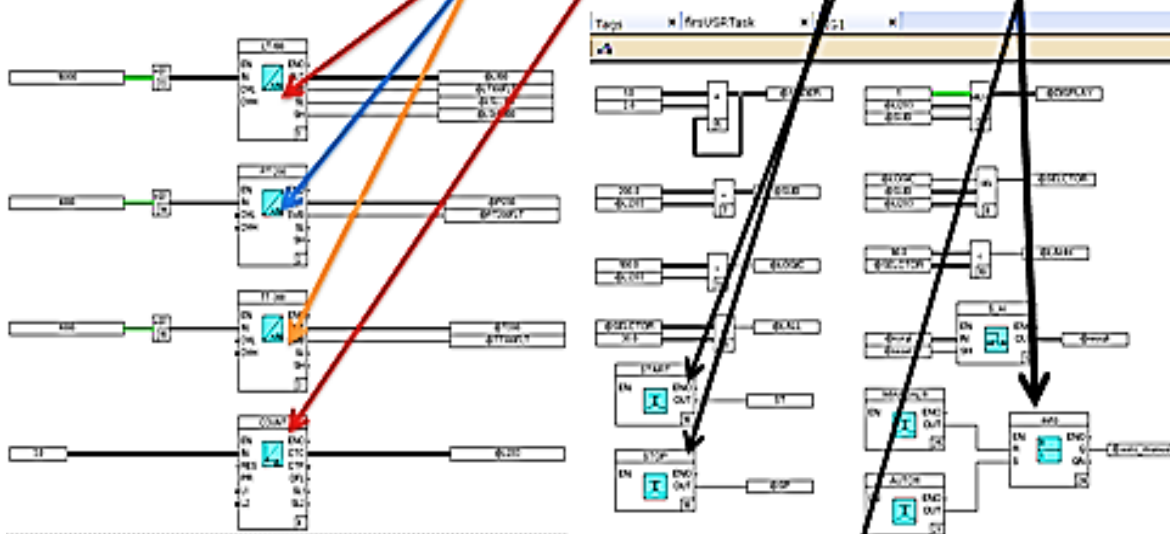

Figure.4-3

Figure.4-4



Figure.4-5

- Finally after complete the configuration you must be check the system configuration sequence by carried out the error check task. This will eliminate the plausibility error check list; if no error listed you can proceed to other step.



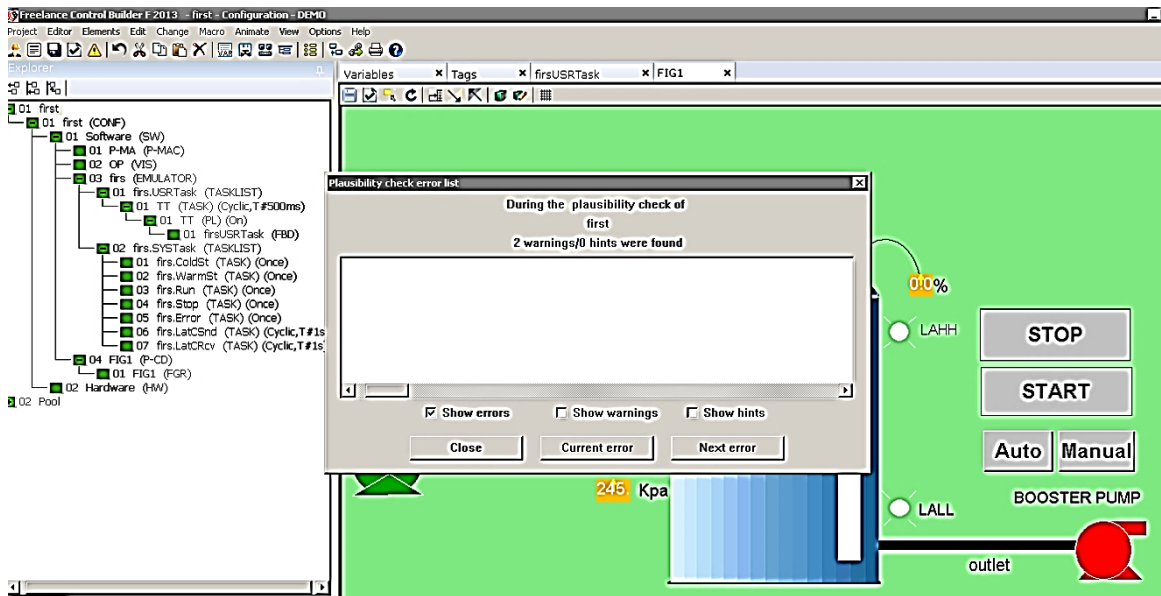

#### 4-2-2 commissioning project:



For healthiness your project you should pass to commissioning project preparing to interface the system simulation that by loading the whole station for both projects station (Emulator) & Operator station or (VIS)

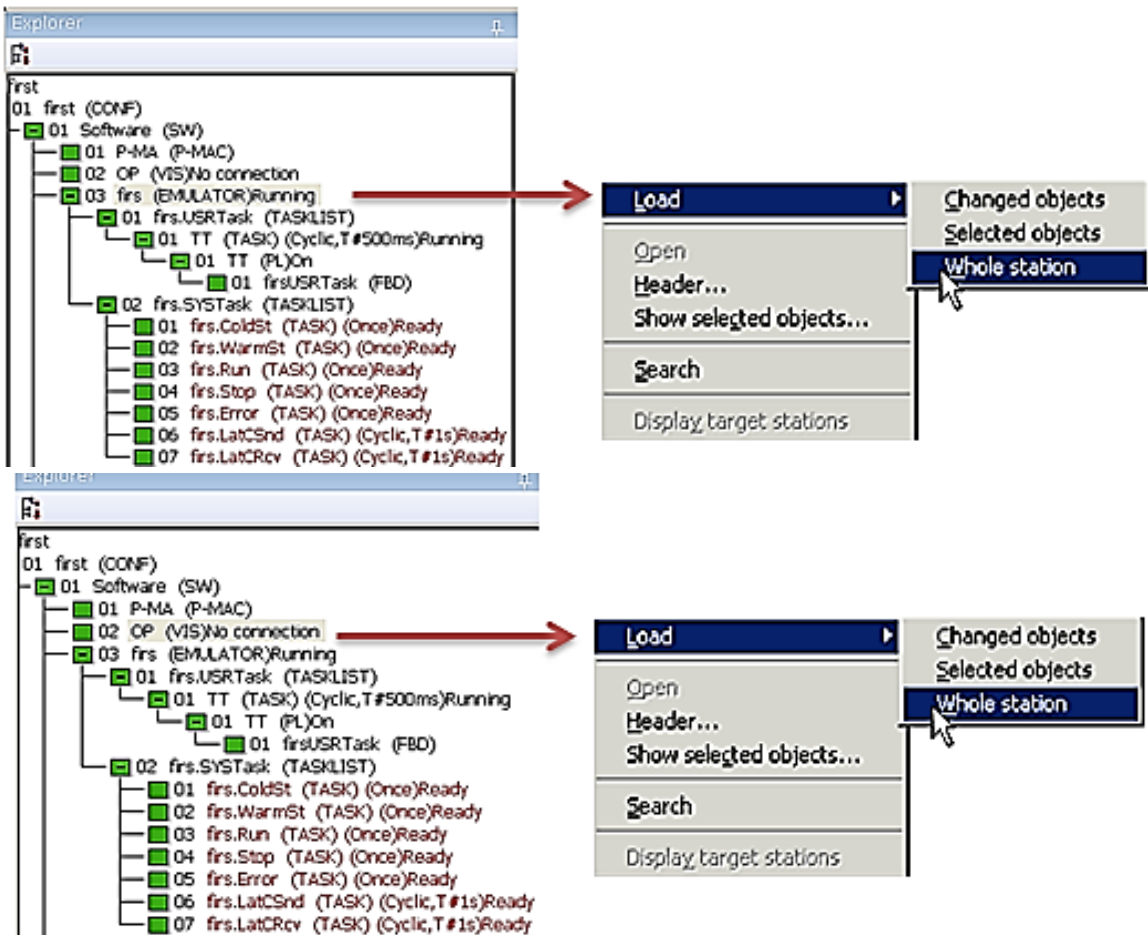





### 4-2-3 Digi-Vis program:



After used the commissioning project task; at same time opened the Digi-Vis program & the website of ABB industrial company local host:http://127.0.0.1:8888 [Frealnce Controller Emulator Administrator Page to activate] on internet explorer see below figure.

Frealnce Controller Emulator Administrator Page 

Station No.	Shutdown	Event Log	GUI Window	Controller WWW-Server
1				

Below you can start a new controller. You must specify a unique station no.

Station No:

---

Last change: May 2013  
Version: V10.1 (8311)

(C) 2013 by ABB / Germany  
If you have any problems please contact your local Frealnce administrator.

Then the project station will appear in DigiVis interface (see below figures for auto & manual modes controlling).

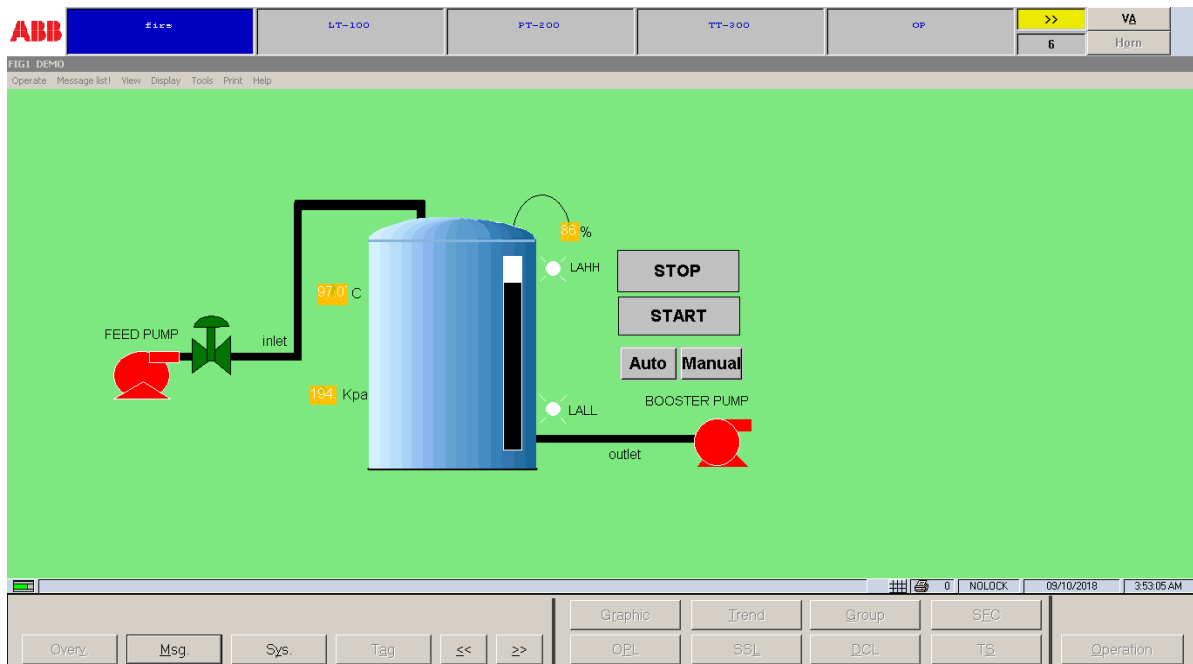

And also Booster pump with local control manually (start/Stop) as per below figure.



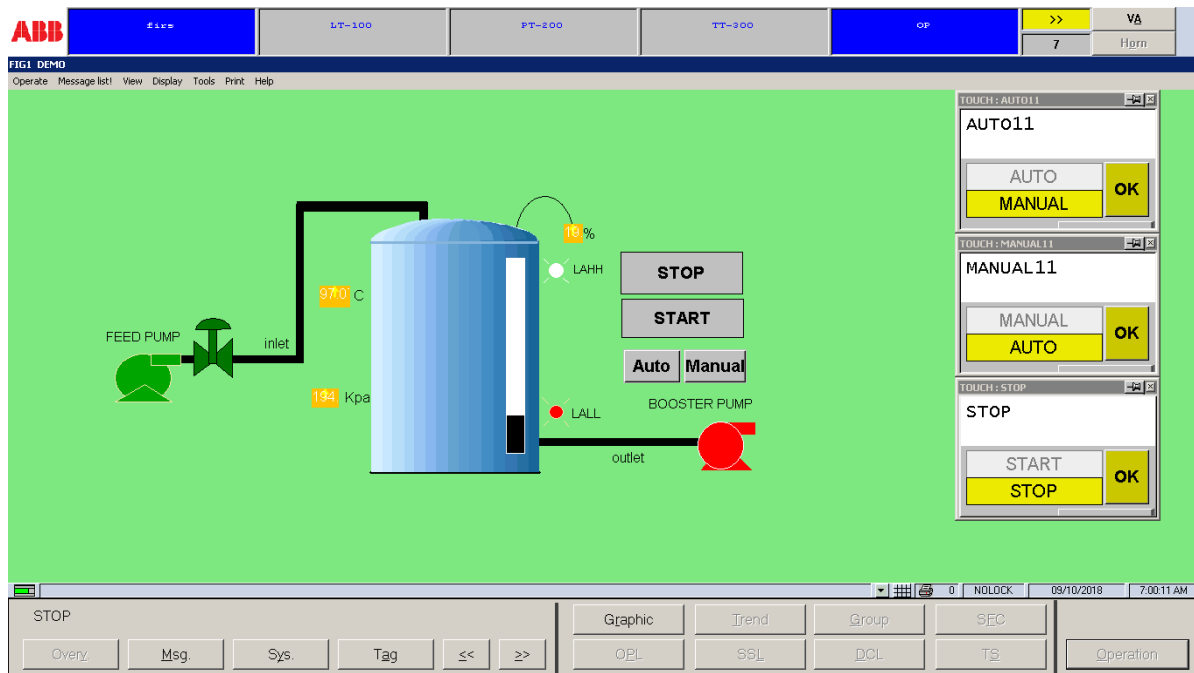

## 4-3 Case study

### 4-3-1 Level switch

The oil tank level sensor is connected on the outside of the tank in diverse positions relying upon the capacity (normal positions are top and base). It has the capacity gather data with respects of the tank level and different parameters utilizing advances like ultrasound and Hall Effect. The sensor accompanies a connection framework and normally controlled by a battery, in some remote areas a sunlight based generator is added to keep the battery charged.

The best approach that can be made to keep oil burglary from the tanks is to utilize an oil tank level screen along with the oil tank level indicator. By utilizing the steel level estimation you can gauge the level of oil in the oil tank. This keeps you educated about the measure of oil in the tank and the level of utilization that is carried out. The oil level screens accompany a sensor alongside a caution that cautions you if there is a drop in the oil level underneath a certain point, educating you therefore if there is the right utilization happening or if the oil has been stolen.

The steel level estimation utilized for oil tanks are tank level pointers which utilize a transmitter over the tank and the ultrasonic level estimation strategies

to quantify the high oil level. The basic system that it uses is that, it has a recipient that conveys data get to; this is further associated with an electric divider attachment that can be kept inside the home. As and when the larger amount of oil in the supply drops to 10 every penny or underneath, the push image shows up, hence educating the holder that the oil tank needs refilling level gauge.

Oil level sensors work the same way that traditional float switches work; except for they work with oil instead of water. Oil level sensors use magnetic reed switches, which are hermitically sealed in a stainless steel or plastic stem, to measure oil levels and automatically turn on or off oil pumps. The reed switch moves up and down the stem to open or break circuits (turn on or off oil pumps) according to oil levels rising and falling.

The crude tank contains unprocessed and unrefined crude oil. Level measurements are necessary to control the amount of oil in the tank and to prevent overflow. To measure the level, non-contact radar level sensors are used. Level sensors which come in contact with the crude oil can fail because crude oil can be very viscous, especially during cold winters. Furthermore, the contacting element often requires maintenance.

#### **4-3-2 Case study of level switched in pumping stations**

The technologies used to measure the level in pumping stations have been traditionally hydrostatic pressure, ultrasonic, or simply switching (on/off) sensors. You may also add to this radar, which is fast becoming a preferred solution to many crude oil and tanks authorities. With the availability of these varied options.

The selection of the level sensor for best performance is determined by many factors including; Range, type of product to be measured, ambient and process conditions, plus mounting position. Each technology has features that will be suited (or may be not suited) to the final application. It is crucial to have an understanding of the principle of operation of these styles of measurement in conjunction with good installation and commissioning by trained personnel. With all factors taken into consideration a reliable level sensor (or sensors) can be installed every time.

In all level monitoring and control applications, but especially pumping stations, there are three important factors to achieve a successful level measurement:

- Selection of the right technology for the application
- Correct mounting position
- Commissioning by a trained person

A crude pumping station is an integral part of pumping. Its primary role is to Collect crude and then pump it from one location to another. The site usually has one or more large, tanks where oil can enter from pump station of incoming Pipes.

A level measuring sensor determines the height of crude oil in the tanks and sends a Signal to a controlling system. The controlling system starts and stops large pumps which Empty the tanks and transfer the oil on its journey towards a crude treatment Plant. Often a line of several tanks pumping stations are needed to transfer the oil from long distances away.

It is important to accurately measure and control the level in tanks primarily to ensure that the tank does not get too high where spills will occur which can harm the environment. Conversely the level cannot get to low as the pumps are designed to allow fluids only and if too much air is injected then damage to the pumps can occur. Much care is taken in the selection of level sensors in tanks to be accurate, reliable, and repeatable he control of the level is usually between about 15-30% to ensure there is enough Capacity in the tanks in case of failure of the pumps. As a backup to the primary level sensor there is usually high and low emergency float Switches which will take over if the level sensor reading is offline.

The level of crude oil in the tanks is measured using a level transmitter. Several different types can use based upon location, conditions, or sometimes simply users Preference. Non-contact sensors like ultrasonic or radar transmitters can be mounted at the top of the pit. Hydrostatic pressure or conductive probes can be inserted into the Medium. A signal from the level transmitter goes to a

controlling and monitoring system which is programmed to start and stop pumps when the level reaches critical points, for example, Start the pump at 30% full and stop the pump at 15% full.

#### **4-3-3 the level sensors types:**

Oil sensors and analysers are used in automotive and industrial applications to gather or send valuable information. They can range from a simple float-type oil level indicator to a complex, in-line laser particle counter and everything in between. This article will outline the different types of oil level sensors, demystify how they work and explain the results they return to the user.

##### ➤ Mechanical Sensors

The mechanical sensor is the simplest and most widely used level sensor. The principle behind magnetic, mechanical, cable and other float level sensors involves the opening or closing of a mechanical switch, either through direct contact with the switch or magnetic operation of a reed. With magnetically actuated float sensors, switching occurs when a permanent magnet sealed inside a float rises or falls to the actuation level. With a mechanically actuated float, switching occurs as a result of the movement of a float against a miniature (micro) switch. The choice of float material also is influenced by temperature-induced changes in specific gravity and viscosity; such changes directly affect buoyancy.

##### ➤ Pneumatic Sensors

Use pneumatic level sensors where hazardous conditions exist, where there is no electric power or its use is restricted, and in applications involving heavy sludge or slurry. Since the compression of a column of air against a diaphragm is used to actuate a switch, no process liquid contacts the sensor's moving parts. These sensors are suitable for use with highly viscous liquids such as grease. This has the additional benefit of being a relatively low-cost technique for point-level monitoring in a lube system.

##### ➤ Ultrasonic Level Transmitters

This type of technology uses sound waves to measure distance. A system usually comprises a sensor which mounts at the top of the pumping station with either an integral or remote transmitter. The transducer of the ultrasonic sensor transmits short high frequency ultrasonic pulses to the measured product. The speed of the sound pulses is about 330m/sec. These pulses are reflected by the product surface and received again by the transducer as echoes. The running time of the ultrasonic pulses from emission to reception is proportional to the distance travelled and hence the level. The determined level is converted into an appropriate output signal and transmitted as a measured value. As the speed of sound can vary depending on the temperature, a temperature sensor is installed in the transducer to compensate for the changes.

➤ Radar Level Transmitters

This type of technology uses microwaves to measure distance. A system usually comprises a sensor which mounts at the top of the pumping station with an integral Transmitter. There are two types of radar level sensor. FMCW (frequency modulated continuous Wave) and pulse radar. In the pulse radar sensor the antenna of the instrument emits short Radar pulses with duration of approximately 1nS. The speed of the microwave pulses is about 300,000km/sec. Similar to an ultrasonic; these pulses are reflected by the product and received by the antenna as echoes. The running time of the microwave pulses from Emission to reception is proportional to the distance travelled and hence the level. The determined level is converted into an appropriate output signal and transmitted as a measured value. The microwaves from a pulse radar have an average power of only about 0.002mW, so are quite suitable for use around people and machines.

➤ Hydrostatic Pressure Transmitters

This type of technology measures pressure. A system usually comprises a submersible Pressure sensor with a length of cable which is terminated outside the pumping station. The pressure forced against a diaphragm is the sum of both the air pressure plus the water Pressure pushing down. This causes a

movement in the measuring cell at the sensor via the diaphragm. The variable atmospheric air pressure is compensated for via a capillary, which runs all the way down the cable to the back of the measuring cell. The two air pressures (one at the front and one at the back) cancel each other out so only the liquid level is considered. The sensor element is a measuring cell with rugged ceramic or thin film metallic diaphragm. Measuring cells are often equipped with a temperature sensor for compensation. Often this temperature change can also be converted into an output. In recent times the use of smart instruments and software can greatly assist in commissioning by offering fast set-ups without the need to empty and fill the vessel. A hydrostatic probe for example can be programmed to the well dimensions and lowered to the correct point, and the output will read correctly straight away. A radar or ultrasonic Transmitter can be programmed after installation using known dimensions. Potential "false echoes" that can occur with these technologies can easily be identified and Suppressed using the software. Generally speaking the most important functions to enter when programming are the minimum and maximum ranges.

# CHAPTER FIVE

## Conclusion & Recommendations of future work

### 5.1 Conclusion

Our project readily achieved its aim of automating the level control process. No human supervision was necessary. The system did not use float sensors yet denoted the accurate level. Hence the short coming of the float sensors that is unwanted vibrations and high cost was easily overcome. The PLC of ABB Freelance control builder F also offers many Input and output ports. Hence this single system can single handedly control as many as 50 tanks making it efficient and cost effective.

We carried out our project and found that DCS & SCADA systems are a very advanced control system. Different aspects of SCADA system have been discussed briefly in the chapter included in the thesis. As we were going on with our project, we got some problems in our way. Collecting data was one of our major problems. Cause no references talking about this issue is available. Another problem is that we couldn't have done the practical side of our project. The reason for that is SCADA is huge and is a fully integrated system that needs a lot of factors to implement even a small branch of it architecture. In addition to what is mentioned we only managed to visit only one pump station, and that is enough to get the complete idea of the practical behaviour of SCADA system.[1], [3]

Generally; there are three important factors need to obtain for a successful level solution in a pumping Station; correct selection of the sensor for the application, ideal mounting position and commissioning by trained persons.

Once the oil in the tank reaches its lowest predetermined point (closed position) the reed switch will create a circuit and automatically send a signal to your pump to start filling your tank up with oil again. The magnetic reed switch will then open the circuit back up again (open position) once the oil level has reached maximum fill capacity.

## **5.2 Recommendations**

Internet and WAP Based Remote Control and Monitoring Alarm messages transferred to the service persons as SMS messages are purely one-way information. If the service person would have the possibility to control the system and change some vital parameters from his mobile phone while being on the field, the total flexibility by the means of a mobile control center can be achieved. The latest improvements in remote control and monitoring techniques involve Internet and WAP Technology to overcome the limitations of traditional monitoring systems described above. The Internet/WAP control and monitoring systems also enable remote monitoring to be offered as service to the municipalities.

The Internet based control and monitoring system allows historical data from the outstations to be viewed and reported from multiple locations, thus enabling the information to be used wherever needed. After typing in the user identification the operation personnel, persons on duty, decision makers, sewage system engineers, etc. are able to browse detailed historical data from the outstations for years backwards e.g. from their own office computers.



## REFERENCES

- [1]. Boys, Walt (18 August 2009). *"Back to Basics: SCADA"*. *Automation TV: Control Global - Control Design*.
- [2]. *"Cyber threats, Vulnerabilities and Attacks on SCADA Networks"* (PDF). Rosa Tang, berkeley.edu. Archived from the original (PDF) on 13 August 2012. Retrieved 1 August 2012.
- [3]. Boyer, Stuart A. (2010). *SCADA Supervisory Control and Data Acquisition*. USA: ISA - International Society of Automation. p. 179. ISBN 978-1-936007-09-7.
- [4]. Jeff Hieb (2008). *Security Hardened Remote Terminal Units for SCADA Networks*. University of Louisville.
- [5]. Aquino-Santos, Raul (30 November 2010). *Emerging Technologies in Wireless Ad-hoc Networks: Applications and Future Development: Applications and Future Development*. IGI Global. pp. 43–. ISBN 978-1-60960-029-7.
- [6]. *"Introduction to Industrial Control Networks"* (PDF). *IEEE Communications Surveys and Tutorials*. 2012.
- [7]. Bergan, Christian (August 2011). *"Demystifying Satellite for the Smart Grid: Four Common Misconceptions"*. *Electric Light & Powers. Utility Automation & Engineering T&D*. Tulsa, OK: PennWell. 16 (8). Four. Retrieved 2 May 2012. *satellite is a cost-effective and secure solution that can provide backup communications and easily support core smart grid applications like SCADA, telemetry, AMI backhaul and distribution automation*
- [8]. *"Office of the manager national communications system"* October 2004. *"Supervisory Control and Data Acquisition (SCADA) Systems"* , national communications system.
- [9]. *"Industrial Security Best Practices"* . Rockwell Automation. Retrieved 26 Mar 2013.

- [10]. *Gordon R. Clarke, Deon Reynders, Edwin Wright, Practical modern SCADA protocols: DNP3, 60870.5 and related systems* Newnes, 2004 ISBN 0-7506-5799-5 pages 19-21  
[https://en.wikipedia.org/wiki/Remote\\_terminal\\_unit](https://en.wikipedia.org/wiki/Remote_terminal_unit)
- [11]. *D'Andrea, Raffaello (9 September 2003). "Distributed Control Design for Spatially Interconnected Systems". IEEE Transactions on Automatic Control. doi:10.1109/tac.2003.816954.*
- [12]. *Massiaoni, Paolo (1 January 2009). "Distributed Control for Identical Dynamically Coupled Systems: A Decomposition Approach". IEEE Transactions on Automatic Control. doi:10.1109/tac.2008.2009574.*
- [13]. [https://en.wikipedia.org/w/index.php?title=Distributed\\_control\\_system&action=history](https://en.wikipedia.org/w/index.php?title=Distributed_control_system&action=history)
- [14]. *Petrodar operation company:*  
<http://www.petrodar.com/content.php?GL=2&PL=9&SL=7>