



# **Sudan University of sciences and Technology**

## **Collage of Engineering**

### **Department of Electrical Engineering**

#### **Distance Protection of Transmission lines using Artificial Neural Networks (ANNs)**

#### **الحماية المسافية لخطوط النقل باستخدام الشبكات العصبية الإصطناعية**

**A Project Submitted In Partial Fulfillment for the Requirements  
of the Degree of B.Sc. (Honor) In Electrical Engineering**

**Prepared by:**

- 1. Alaa Mohammed Babiker Dafaallah**
- 2. Hana AbdElgani Mohammed Osman Salih**
- 3. Sara Siddig Alnow Ali**
- 4. Zainab Taha Ibrahim Ali**

**Supervised by:**

**Dr. Salah Eldeen Gasim Mohammed**

**October 2018**



## الآية

قال تعالى:

(اللَّهُ نُورُ السَّمَاوَاتِ وَالْأَرْضِ ۚ مَثَلُ نُورِهِ كَمِشْكَاةٍ فِيهَا مِصْبَاحٌ ۚ الْمِصْبَاحُ فِي زُجَاجَةٍ ۚ الزُّجَاجَةُ  
كَأَنَّهَا كَوْكَبٌ دُرِّيٌّ يُوقَدُ مِنْ شَجَرَةٍ مُبَارَكَةٍ زَيْتُونَةٍ لَا شَرْقِيَّةٍ وَلَا غَرْبِيَّةٍ يَكَادُ زَيْتُهَا يُضِيءُ وَلَوْ لَمْ تَمْسَسْهُ  
نَارٌ ۙ نُّورٌ عَلَى نُورٍ ۗ يَهْدِي اللَّهُ لِنُورِهِ مَنْ يَشَاءُ ۚ وَيَضْرِبُ اللَّهُ الْأَمْثَالَ لِلنَّاسِ ۗ وَاللَّهُ بِكُلِّ شَيْءٍ عَلِيمٌ)

"صدق الله العظيم"

سورة النور الآية (35)

## **DEDICATION**

To my parents, family and friends for their relentless love and their support both financially and emotionally during the course of my research and thereby making this project a success.

## **Acknowledgments**

In the name of Allah, Most Gracious, and Most Merciful Praise be to Almighty Allah who gave ours the courage and patience to carry out this work.

Firstly, I would like to sincerely express my gratitude to my advisor and my thesis chair Dr. Salah-aldeen Gasim for all his support and cooperation without which this project would never have been possible. We thank him for his constant patience and the financial support he offered to ours during the course of my research.

# Abstract

Transmission lines, among other electrical power system components, suffer from unexpected failures due to various random causes. These failures interrupt the reliability of the operation of the power system. When unpredicted faults occur, protective systems are required to prevent the propagation of these faults and safeguard the system against the abnormal operation resulting from them. The function of these protective systems are to detect and classify faults as well as to determine the location of the faulty line when a fault is detected in the voltage and current line magnitudes. Once the fault is detected and classified the protective relay sends a trip signal to a circuit breakers in order to disconnect (isolate) the faulted line.

The features of neural networks, such as their ability to learn, generalize and parallel processing, among other, have made their applications on many systems ideal. The use of neural networks as pattern classifiers is among their most common and powerful applications.

The project presents a back-propagation artificial neural network architecture approach to detection, classification and location of faults in transmission line system. The objective is to implement a complete scheme for distance protection of a transmission line system. In order to perform this goal, the distance protection task is subdivided into different neural networks for fault detection, fault classification as well as fault location in different zones.

## المستخلص

تعاني خطوط نقل القدرة الكهربائية كباقي مكونات نظام القدرة من الأعطال نتيجة لاسباب متنوعة و مختلفة. تؤثر هذه الأعطال على كفاءة عمل منظومة القدرة الكهربائية. عند ظهور الأعطال الغير متوقعة فإن نظم الحماية مطلوبة لمنع انتشار هذه الأعطال وحماية النظام من العمليات الغير طبيعية الناتجة عنها. إن وظيفة نظم الحماية إكتشاف و تصنيف هذه الأعطال بالإضافة الى تحديد موقع الخط المعطل عند اكتشاف العطل من قيمة مطال موجة الجهد و التيار في الخط. بعد اكتشاف العطل وتصنيفه فإن مرحل الحماية ( Protective Relay ) يرسل اشارة قطع (Trip Signal) لقاطع الدائرة (Circuit Breaker) لعزل الخط المعطل.

إن خصائص الشبكات العصبية الاصطناعية (Artificial neural networks) كمقدرتها على التعلم و التعميم و المعالجة المتوازية من بين الاخریات جعلت تطبيقها على العديد من الأنظمة مثالیا. كما يعتبر استخدام الشبكات العصبية الاصطناعية كنمط للتصنيف من التطبيقات الشهيرة و الفعالة.

إن هذا البحث يستعرض استخدام خوارزمية الانتشار العكسي (Back Propagation Architecture) كنهج لإكتشاف الأعطال و تصنيفها و تحديد موقعها في خطوط نقل القدرة الكهربائية. الهدف من هذا البحث دراسة مخطط متكامل للوقاية المسافية (Distance Protection) لخطوط نقل القدرة الكهربائية. ولتحقيق هذا الهدف قسم مخطط الوقاية المسافية الى عدة دوائر عصبية اصطناعية لإكتشاف الأعطال وتصنيفها وتحديد موقع العطل من عدة مواقع.

# TABLE OF CONTENTS

	Page No
الأية	I
DEDICATION	II
ACNOWLEDGEMENT	III
ABSTRACT	IV
مستخلص	V
TABLE OF CONTENTS	VI
TABLE OF FIGURES	IX
TABLE OF TABLES	XI
TABLE OF ABBREVIATIONS	XII
<b>CHAPTER ONE INTRODUCTION</b>	
1.1 Overview	1
1.2 Problem Statement	3
1.4 Project Objectives	3
1.4 Project Outlines	4
<b>CHAPTER TWO LITERATURE REVIEW</b>	
2.1 General View	5
2.2 Power System Network	6
2.3 Faults	7
2.4 Power System Protection	12
2.5 Distance Protection	18

<b>CHAPTER THREE</b>	
<b>METHODOLOGY</b>	
3.1 Introduction	19
3.2 Transmission Lines Model	20
3.3 Symmetrical Component	21
3.4 Fault Detection Technique	24
3.5 Fault Location Determination Technique	26
3.6 Artificial Neural Network (ANNs)	29
3.7 Type of Neural Networks	33
3.8 Learning Strategy	36
3.9 Advantages and Disadvantages of ANN	38
<b>CHAPTER FOUR</b>	
<b>RESULTS AND DISCUSSION</b>	
4.1 Introduction	40
4.2 The transmission line under study	40
4.3 Overview of the Training Process	50
4.4 Overview of the Testing Process	51
4.5 Fault Detection	52
4.6 Fault Classification	55
4.7 Fault Location	59



<b>CHAPTER FIVE</b>	
<b>CONCLUSI AND RECOMMENDATION</b>	
5.1 Conclusion	62
5.2 Recommendations	63
<b>REFERENCES</b>	64
<b>APPENDIX</b>	66

## LIST OF FIGURES

Figure No.	Title	Page No.
2.1	General representation of a single line-to-ground fault.	10
2.2	General representation of double line fault.	10
2.3	General representation of double line- to-ground.	11
3.1	Pi network for a transmission line model.	20
3.2	Representation of Symmetrical Component.	22
3.3	Faulted Transmission Line illustrating simple-reactance method.	28
3.4	Schematic diagram of a neuron.	30
3.5	Representation of a perceptron	31
3.6	Step activation function.	32
3.7	Linear activation function.	32
3.8	Binary activation function.	33
3.9	Sigmoid function.	33
3.10	Structure of a two-layered feed forward network.	35
3.11	Representation of Feedback Network.	36
3.12	Scheme of supervised learning.	37
4.1	A single line diagram of transmission line.	41
4.2	Three Phase test system model in MATLAB/SIMULIN.	42
4.3	Current waveforms at normal condition.	48
4.4	Current waveforms at single line-to-ground fault.	48

4.5	Current waveforms at line-to-line fault.	49
4.6	Current waveforms at double line-to-ground fault.	49
4.7	Current waveforms at three line fault.	50
4.8	Plot of the training performance the neural network 6-10-1.	54
4.9	Confusion matrices for Training, Testing and Validation Phases.	55
4.10	Performance plot of one hidden layer.	58
4.11	The Receiver Operating Characteristics curve (ROC).	59
4.12	Performmance plot of the location of the network.	61

## LIST OF TABLES

2.1	Fault type and their frequencies.	9
4.1	Sample of Inputs to the neural network for various fault cases far of 15 Km from the source.	43
4.2	Sample of Inputs to the neural network for various fault cases far of 30 Km from the source.	44
4.3	Sample of Inputs to the neural network for various fault cases far of 60 Km from the source.	45
4.4	Sample of Inputs to the neural network for various fault cases far of 90 Km from the source.	46
4.5	Sample of Inputs to the neural network for various fault cases far of 120 Km from the source.	47
4.6	Fault classifier ANN outputs for various faults.	57
4.7	Isolation NN Training Set.	60

## LIST OF ABBREVIATIONS

ANN	Artificial Neural Network.
HV	High Voltage.
AC	Alternative Current.
KVL	Kirchhoff's Voltage Low.
KCL	Kirchhoff's Current Low.
LV	Low Voltage.
SLG	Single Line-Ground.
LL	Line-Line.
LLG	Line-Line-Ground.
CTs	Current Transformers.
VTs	Voltage Transformers.
DFT	Discrete Fourier Transform.
DSP	Digital Signal Processor.
SF6	Sulphurhexa Fluoride
MRA	Multi Resolution Analysis.
FIS	Fuzzy Interference System.
ANFIS	Adaptive Neuro Fuzzy Interference System.
SGN	Signum.
ROC	Receiver Operating Characteristic.
BP	Back Propagation.

# CHAPTER ONE

## INTRODUCTION

### 1.1 Overview

In the past several decades, there has been a rapid growth in the power grid all over the world which eventually led to the installation of a huge number of new transmission and distribution lines. Moreover, the introduction of new marketing concepts such as deregulation has increased the need for reliable and uninterrupted supply of electric power to the end users who are very sensitive to power outages. One of the most important factors that hinder the continuous supply of electricity and power is occurrence of a faults in the power system. Hence, it is very important to have a well-coordinated protection system that detects any kind of abnormal flow of current in the power system, identifies the type of fault and then accurately locates the position of the fault in the power system.

The faults are usually taken care of by devices that detect the occurrence of a fault and eventually isolate the faulted section from the rest of the power system. Hence some of the important challenges for the incessant supply of power are detection, classification and location of faults. Faults can be of various types namely transient, persistent, symmetric or asymmetric faults and the fault detection process for each of these faults is distinctly unique in the sense, there is no one universal fault location technique for all these kinds of faults. The High Voltage Transmission Lines (that transmit the power generated at the generating plant to the high voltage substations) are more prone to the occurrence of a fault than the local distribution lines (that transmit the power

from the substation to the commercial and residential customers) because there is no insulation around the transmission lines unlike the distribution lines

The automatic location of faults can greatly enhance the systems reliability because the faster we restore power, the more money and valuable time we save. Hence, many utilities are implementing fault locating devices in their power quality monitoring systems that are equipped with Global Information Systems for easy location of these faults.

From quite a few years, intelligent based methods are being used in the process of fault detection and location. Among these available techniques, Artificial Neural Networks (ANN) have been used extensively in this research for fault location on electric power transmission lines. These ANN based methods do not require a knowledge base for the location of faults unlike the other artificial intelligence based methods.

Human perform various complex nonlinear tasks with the aid of information processing via biological neural networks. This is done by the huge amount of complex interconnections of the neuronal cells (neurons) which interact amongst each other by exchanging brief electrical pulses or action potential. The biological neural network is the motivation of its computer science version, popularly known as artificial neural networks (ANN). Many scientists and engineers, however, often drop the initial artificial tag to name it just neural network.

Inspired by the biological nervous system, ANN operates on the principle of largely interconnected simple elements operating as a network function. In doing so, no previous knowledge is assumed, but data, record, measurements, observations are considered. ANN research stands on the fact of learning from data to mimic the biological capability of linear nonlinear problem solving.

Due to the possibility of training neural networks with off-line data, they are found useful for power system applications. The neural networks applications in transmission line protection are mainly concerned with improvements in achieving more efficient fault diagnosis and distance relaying.

## **1.2 Problem Statement**

Occurrence of faults in power systems leads to large damages. It interrupts the operation of the power system, deteriorates the reliability of the system, and causes power system components damage. The heavy currents result in the excessive heating of lines, cables and winding resulting in fire or explosion. Also, Stability of the system may be adversely affected, cascade tripping of power system components may take place, and complete blackout may occur. If the fault is not cleared quickly arc on over-head transmission lines may burn the conductors causing it to break resulting in long time interruption of the supply. If the fault detected mistakenly the fault will not clear and the above problem still unsolved so it is important to know the type and zone of the fault to be cleared correct. There are many problems faced the fault classification methods. As in impedance method the fault detection is slow and the results are inaccurate. Mistaken fault report sent to control centers or directly fed to protection systems may deteriorate the problem. It may cause tripping healthy parts and leaving behind faulty parts.

## **1.3 Objectives**

The main objectives of this project are:

1. To perform fault analysis in a real transmission line.
2. To train an artificial neural network (ANN) using the different results of fault analysis.
3. To utilize neural network techniques for fault detection.



4. To utilize neural network techniques for classification of type of fault.
5. To utilize neural network techniques for Location of type of fault.

## **1.4 Project Outlines**

Chapter two introduces general view of power system focusing on transmission lines and their models. It deals with the several problems that hinder the protection of a typical transmission line system, and the symmetrical components (since is the method of fault analysis). The various kinds of faults and the protection techniques that are currently available and employed are briefly discussed.

Chapter three introduces with the types of fault analysis methods (conventional and AI based methods) and the concept behind artificial intelligence and neural networks. A few ANN architectures that are usually employed are discussed and the various learning strategies employed in the training process of the neural networks along with the critical factors that affect the size and output of a trained network are discussed in this chapter.

Chapter four deals with the transmission line model and presents series of simulation results that have been obtained using MATLAB, SimPower Systems .An overview of the training and testing processes employed with neural networks in this work has been outlined in this chapter. The Artificial Neural Networks Toolboxes in simulink in detail to emphasize the efficiency and accuracy factors of the proposed fault locator. Several neural networks with varying configurations have been trained, tested and their performances have been analyzed in this chapter. Chapter five present the conclusion and recommendations of the research.

# **CHAPTER TWO**

## **LITERATURE REVIEW**

### **2.1 General View**

Fault studies form an important part of power system analysis .There are different types of faults. Faults on power transmission lines are divided into three phase balanced faults and unbalanced faults. Different types of unbalanced faults are the single line to ground fault, line to line fault, and double line to ground fault.

In Electric power system, when transmission line fault occurs, plenty of transient components of different frequency will be generated. A lot of fault information is included in the transient components. That can be used to predict, deal and analyze the fault of equipment or power system, therefore the reliability of the power system will be considerably improved. Although we can accurately obtain large amounts of various fault transient information in time, the key problem is how to use those transient signals to detect and classify fault. Therefore, the new information mergence methods and the effective technology used in detection and classification of electric power system faults transient need to be studied.

A power system, when affected by faults, will result in the disruption of power flow. It is absolutely essential to find the fault location so as to repair and restore the electrical flow. The location of faults must be determined quickly and accurately to improve the economy, safety and reliability of such a power system.

## **2.2 Power System Network**

For most practical purpose the electrical network may be divided into three parts namely generation, transmission, and distribution.

### **2.2.1 Power generation**

Electrical power is generated by converting the potential energy into electrical energy such as direct conversion of kinetic energy wind or water turbines or creating steam from boilers to drive the turbines.

### **2.2.2 Power transmission**

The generated electrical power transmitted via transmission lines, usually over long distances with high voltage (HV) through a substations are directly connected the power grid with two or more incoming and outgoing lines, to improve substation's reliability. Normally a high voltages range is 132-800 KV.

Overhead lines are far cheaper than underground cables for long distances. Mainly due to the fact that air is used as the insulation medium between phase conductors, and that no excavation work is required. The support masts of overhead lines are quite a significant portion of the costs that is the reason why aluminum lines are often used instead of copper, as aluminum lines weight less than copper, and are less expensive.

Overhead lines are prone to lightning strikes, causing a temporary surge on the line, usually causing flashover between phases or phase to ground. The line insulators are normally designed to relay the surge to ground, causing the least disruption and/or damage. This is of short duration, and as soon as it is cleared, normal operation may be resumed. Overhead lines have properties of being less expensive for longer distances and easy to locate fault. While they are more expensive for shorter distances, susceptible to lightning, not environment-

friendly which results in maintenance intensive and high level of expertise and specialized equipment needed for insulation.

### **2.2.3 Distribution and utilization**

Power distribution is normally done on the medium-voltage level, in the range of 6.6-33 KV. Three-phase power is transferred, mostly via overhead lines or 3-core MV power cables buried in trenches. Single core-insulated cables are also used, although less often.

The distribution voltage is then transformed to low voltage (LV), either for lighting and small power application.

## **23 Faults**

in this section introduced :

### **2.3.1 Nature of Faults**

A fault on a power system is an abnormal condition that involves an electrical failure of power system equipment operating at one of the primary voltages within the system. Generally, two types of failure can occur. The first is an insulation failure that results in a short-circuit fault and can occur as a result of overstressing and degradation of the insulation over time or due to a sudden over-voltage condition. The second is a failure that results in a cessation of current flow or an open-circuit fault. On mainly underground systems, the vast majority of short-circuit faults are weather related followed by equipment failure. The weather factor that usually cause short-circuit faults are lightning strikes, heavy rain, strong wind or gales, salt pollution depositing on insulators on overhead lines and in substation, floods and fires adjacent to electrical equipment. Equipment failure, e.g. machines, transformers, reactors, cables, etc., causes many short-circuit faults. These may be caused failure of internal insulation due to ageing degradation, breakdown due to high switching or

lightning over-voltages, by mechanical incidents or by inappropriate insulation. Short-circuit faults may also be caused by human error. A three phase to earth short-circuit fault occurs when the equipment is re-energized to return it to service. On mainly overhead line systems, the majority of short-circuit faults, typically 80-90%, tend to occur on overhead lines and the rest on substation equipment and bus-bars combined.

### **2.3.2 Causes and effects**

A fault in the electrical equipment is defined as a defect in its electrical circuit due to which the flow of current is diverted from the intended path. Faults are caused by breaking of conductors or failure of insulation. Fault impedance is generally low, and fault current is generally high. During the faults, the voltages of the three phases become unbalanced and the supply to the neighboring circuits is affected. Fault currents being excessive, they can damage not only the faulty equipment, but the insulation through which the fault current is fed. Faults in certain important equipment can affect the stability of the power system. For example, a fault in the bus-zone of a power station can cause tripping of all the generator units in power station and can affect the stability of the interconnected system.

There are several causes of fault occurring in a particular electrical plant. Faults can be minimized by improved system design, improve quality of components, better and adequate protective relaying, better operation and maintenance, etc.

### **2.3.3 Type of common faults**

The normal operating mode of a power system is a balanced three-phase alternative current (AC). However, there are four common faults may cause

balanced and/or unbalance operation conditions.

Table (2.1) Fault type and their frequencies:

<b>Fault Type</b>	<b>Relative Frequencies</b>
Single-line-to-ground (SLG)	70%
Line-to-line (LL)	15%
Line-to-line-to-ground (2LG)	10%
Other faults	5%
<b>TOTAL</b>	<b>100%</b>

Sometimes instead of using “line” in these fault types, “phase” is used. This section will drive the connections of sequence networks associated with these four faults.

A three-phase system, as shown in Figure (2.1) is used for the development of sequence networks for different fault conditions, note that labeled currents  $I_a$  ,  $I_b$  and  $I_c$  are not the line currents during normal operation conditions. Instead, these currents are fault currents during various type of faults. Therefore, they have a zero value during normal conditions. It is important to assume that there may be some impedance between lines and the ground involved in various faults while developing the sequence networks.

### **2.3.3.1 Single-Line-to-Ground (SLG)**

Single-line-to-ground (SLG) fault (or phase-to-ground fault). As shown in Figure (2.1), a SLG fault is commonly analyzed with phase “a” connecting the ground through the fault impedance  $Z_f$ .

$$I_b = I_c = 0 \tag{2.4}$$

And

$$V_a = I_a Z_f \tag{2.5}$$

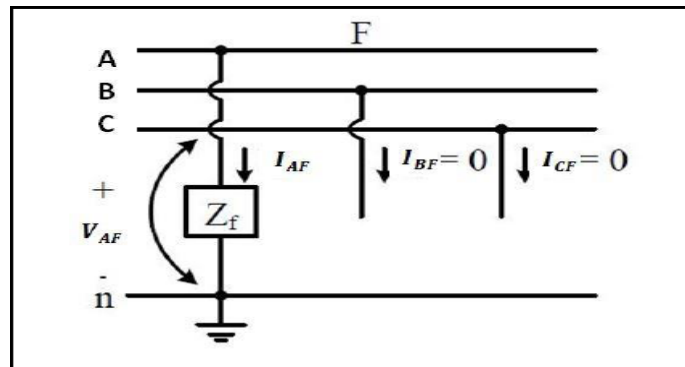

Figure (2.1): General representation of a single line-to-ground fault.

### 2.3.3.2 Line-to-Line Fault (LL)

Line-to-line (LL) fault or phase-to-phase fault is commonly analyzed as phase “b” and “c” connected together through the fault impedance  $Z_f$  while the phase “a” is open, as shown in Figure (2.2).

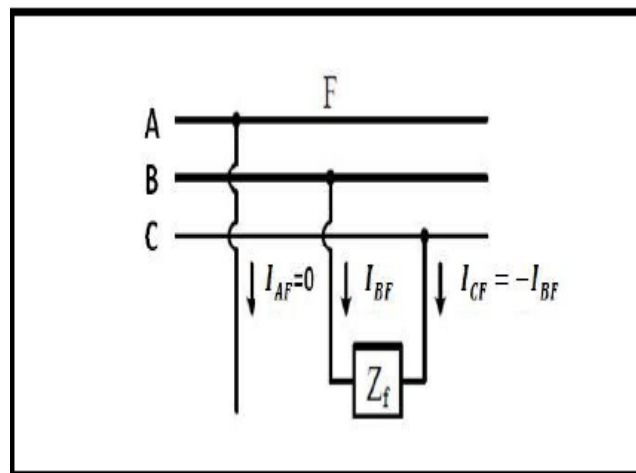

Figure (2.2): General representation of double line fault.

### 2.3.3.3 Line-to-Line-to-Ground (2L G) Fault

The last common type of faults is the line-to-line-to-ground (2L G) fault. Usually the analysis of this type of faults is done with the assumption of phases “b” and “c” shorted together, then, connected the ground through the impedance  $Z_f$ , while phase “a” is open, as shown in Figure (2.3).

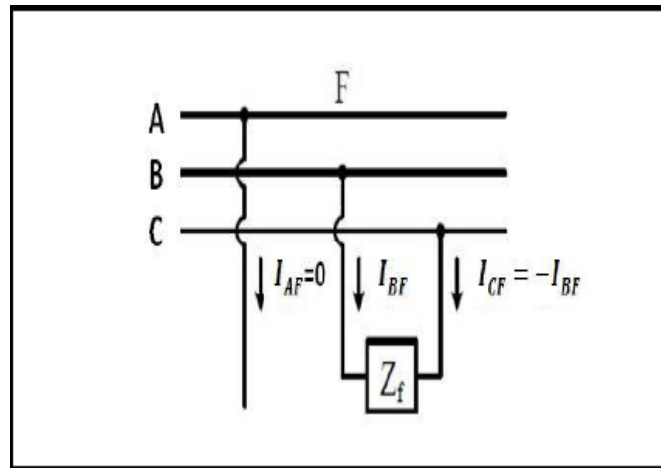

Figure (2.3): General representation of double line- to-ground.

The following three facts can be observed from Figure (2.3):

$$I_a = 0 \tag{2.6}$$

$$V_a = V_c \tag{2.7}$$

And

$$V_b = (I_b + I_c)Z_f \tag{2.8}$$



Recall that the sequence networks for four types of fault are obtained with the assumption of the existence of fault impedance  $Z_f$ . However, in some situation, the calculations may be done with a direct shorted fault. In such cases  $Z_f = 0$ . It implies that a short circuit needs to replace the  $Z_f$  for all of the four sequence network connections.

## 2.4 Power System Protection

Power System Protection is the system that should place to protect the electrical power System from the faults that may happen and make the system under the critical situation. This system has to keep the electrical power system stable, continuous and efficient by reducing the effect of the faults to the lowest property. So, there are several conditions (as below) to adopt or build this system to reduce the fault's effects (inner and outer) to the lower possible limit and keep the electrical power system works properly under and after the fault occurs:

a. Speed:

It is the time that will spend to make the decision if there is a fault or not.

b. Accuracy:

It is the ability to recognize the behavior of the equipment in the electrical power system.

c. Simplicity:

The simplicity of the installation of relay protection is an essential factor in the efficiency and reliability of the relay and the speed of installation and maintenance.

d. Reliability:

It is the ability of the system to work when it should work, that means the system will work when the equipment became abnormal due to the fault.

e. Sensitivity:

It is defined as the ability of the system to find the abnormal behavioral of the electrical power system, when it is exceeding the normal operation, and it considers the efficient of this system.

f. Security:

It is the ability of the system to prevent unnecessary operation when the electrical power system works normal.

g. Economics:

The economy is one of the most important principles of the design and operation of any system. And there are many conditions to adopt and build the Protection System, due to the requirements for the system that wants to be protected. The circumstance played the basic role in these equations.

A fault, which is an abnormal system condition, occurs as a random event. Short circuits occur in power systems when equipment insulation fails, due to system overvoltage caused by lightning or switching surge, to insulation contamination, or to other mechanical and natural causes. Careful design, operation, and maintenance can minimize the occurrence of short circuits but cannot eliminate them. The faulty system component (line, bus, transformer, etc.) must be isolated from the system quickly to prevent power system instability or break-up of the system through the action of other protective devices. Therefore, a protection system must be designed to disconnect the faulted component from the system as quickly as possible.

### **2.4.1 Protection System Components**

Protection systems have three basic components:

1. Instrument transformers.
2. Protective Relays.
3. Circuit breakers.

### 2.4.1.1 Instrument Transformers

There are two type of instrument transformers, voltage transformers (VTs) and current transformers (CTs).

- **Advantages of instruments transformers**

1. **Safety:** Instrument transformers provide electrical isolation from the power system so that personnel working with relays will work in a safer environment.
2. **Economy:** Lower-level relay inputs enable relays to be smaller, simpler, and less expensive.
3. **Accuracy:** Instrument transformers accurately reproduce power system currents and voltages over wide operating ranges.

### 2.4.1.2 Protective Relays

Relays are compact analog, digital, and numerical devices that are connected throughout the power system to detect intolerable or unwanted conditions within assigned area. They, in effect, are a form of active insurance designed to maintain a high degree of service continuity and limit equipment damage, other types of relays applied on a more limited basis or used as part of a total protective relay system will also be covered.

The electromechanical relay in all of its different forms has been replaced successively by static, digital, and numerical relays, each change bringing with it reductions in size and improvements in functionality. Reliability levels have also been maintained or even improved and availability significantly increased due to techniques not available with older relay types. This represents a tremendous achievement for all those involved in relay design and manufacture. This modern digital and numerical protection relay technology is being used, although in the past

number of electro mechanical and static relays are still giving dependable services.

### **1. Electromechanical Relays**

These relays were the earliest forms of relays used for the protection of the power system. They work on the principle of mechanical force causing operating of a relay contact in response to a stimulus. The mechanical force is generated through current flow in one or more winding on a magnetic core or cores, hence the term electromechanical relay. Electromechanical relays can be classified into several different types as follow:

- Attracted armature.
- Moving coil.
- Thermal.
- Motor-operated.
- Mechanical.

However, only attracted armature type have significant application at this time, all other types having been superseded by modern equivalents.

### **2. Static Relays**

The term (static) implies that the relay has no moving parts. This is not strictly the case for a static relay, as the output contacts are still generally attracted armature relays. In a protection relay, the term (static) refers to the absence of moving parts to create the relay characteristic. Their design is based on the use of analog electronic devices instead of coils and magnets to create the relay characteristic. Early version use used discrete devices such as transistors, inductors, etc.

### **3. Digital Relays**

Digital protection relays introduced a step change in technology. Microprocessors and microcontrollers replaced analogue circuits used in static relays to implement relay functions. Early examples began to be introduced into service around 1980, and, with improvements in processing capacity, can still be regarded as current technology for many relay applications.

However, such technology will be completely superseded within the next five years by numerical relays. Compared to static relays, digital relays introduce A/D conversion of all measured analogue quantities and use a microprocessor to implement the protection algorithm. The microprocessor may use some kind of counting technique, or use the Discrete Fourier Transform (DFT) to implement the algorithm.

### **4. Numerical Relays**

The distinction between digital and numerical relay rests on points of fine technical detail, and is rarely found in areas other than Protection. They can be viewed as natural developments of digital relays as a result of advances in technology. Typically, they use a specialized digital signal processor (DSP) as the computational hardware, together with the associated software tools. The input analogue signals are converted into a digital representation and processed according to the appropriate mathematical algorithm. Processing is carried out using a specialized microprocessor that is optimized for signal processing applications, known as a digital signal processor or DSP for short. Digital processing of signals in real time requires a very high power microprocessor.

#### **2.4.1.3 Circuit breakers**

Where fuses are unsuitable or inadequate, protective relays and circuit breakers are used in combination to detect and isolate faults. Circuit breakers are the main making and breaking devices in an electrical circuit to allow or disallow flow of power from source to the load. These carry the load currents

continuously and are expected to be switched ON with loads (making capacity). These should also be capable of breaking a live circuit under normal switching OFF conditions as well as under fault conditions carrying the expected fault current until completely isolating the fault side (rupturing/breaking capacity).

Under fault conditions, the breakers should be able to open by instructions from monitoring devices like relays. The relay contacts are used in the making and breaking control circuits of a circuit breaker, to prevent breakers getting closed or to trip breaker under fault conditions as well as for some other interlocks.

The types of breakers basically refer to the medium in which the breaker opens and closes. The medium could be oil, air, vacuum or SF<sub>6</sub>. The further classification is single break and double break. In a single break type only the bus bar end is isolated but in a double break type, both bus bar (source) and cable (load) ends are broken. However, the double break is the most common and accepted type in modern installations.

### **2.4.2 Transmission Line Protection**

Transmission line protection is required because it can be affected by the changing of the environment. So, in the design of the transmission line must take into account all possible changes that may cause any abnormal behavior.

There are many types of protection applied to the transmission line as below:

- a. Differential protection.
- b. Distance protection.
- c. Directional protection.
- d. Over current protection.
- e. Lightning protection.
- f. Earth fault protection.

## **2.5 Distance Protection**

The problem of combining fast fault clearance with selective tripping of plant is a key aim for the protection of power systems. To meet these requirements, high speed protection systems for transmission and primary distribution circuits that are suitable for use with the automatic reclosed of circuit breakers are under continuous development and are very widely applied. Distance protection, in its basic form, is a non-unit system of protection offering considerable economic and technical advantages. Unlike phase and neutral overcurrent protection, the key advantage of distance protection is that its fault coverage of the protected circuit is virtually independent of source impedance variations. Distance protection is comparatively simple to apply and it can be fast in operation for faults located along most of a protected circuit. It can also provide both primary and remote back-up functions in a single scheme. It can easily be adapted to create a unit protection scheme when applied with a signaling channel. In this form it is eminently suitable for application with high-speed auto reclosing, for the protection of critical transmission lines.

# CHAPTER THREE

## METHODOLOGY

### 3.1 Introduction

The fault analysis of a power system is required in order to provide information for the selection of switchgear, setting of relays and stability of system operation. A power system is not static but changes during operation (switching on or off of generators and transmission lines) and during planning (addition of generators and transmission lines). Thus fault studies need to be routinely performed by utility engineers. Faults usually occur in a power system due to either insulation failure, flashover, physical damage or human error. These faults, may either be three balanced phase faults may be analyzed using an equivalent single phase circuit. With asymmetrical three phase faults, the use of symmetrical components help to reduce the complexity of the calculations as transmission lines and components are by and large symmetrical, although the fault may be asymmetrical. Fault analysis is usually carried out in per-unit quantities (similar to percentage quantities) as they give solutions which are somewhat consistent over different voltage and power ratings, and operate on values of the order of unity phase in nature involving all three phases in a symmetrical manner, or may be asymmetrical where usually only one or two phases may be involved. Faults may also be caused by either short-circuits to earth or between live conductors, or may be caused by broken conductors in one or more phases. Sometimes simultaneous faults may occur involving both short-circuit and broken conductor faults (also known as open-circuit faults).



## 3.2 Transmission Lines Model

The commonly modeled used for AC overhead transmission is called pi model network and shown in Figure (3.1). Where shunt admittance has been even divided into two shunt elements connecting to both ends of a pi equivalent networks.

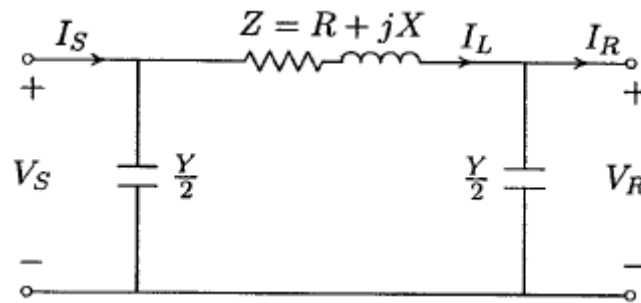

Figure (3.1): pi network for a transmission line model.

By Kirchhoff's voltage law (KVL) analysis:

$$\vec{V}_s = \vec{Z} \left( \vec{I}_r + \frac{\vec{Y}}{2} \vec{V}_r \right) + \vec{V}_r = \left( 1 + \frac{\vec{Z}\vec{Y}}{2} \right) \vec{V}_r + \vec{Z}\vec{I}_r \quad (3.1)$$

And by Kirchhoff's current law (KCL) analysis:

$$\vec{I}_s = \frac{\vec{Y}}{2} \vec{V}_s + \left( \vec{I}_r + \frac{\vec{Y}}{2} \vec{V}_r \right) = \left( \vec{Y} + \frac{\vec{Z}\vec{Y}^2}{2} \right) \vec{V}_r + \left( 1 + \frac{\vec{Z}\vec{Y}}{2} \right) \vec{I}_r \quad (3.2)$$

Where

$\vec{V}_s$  = the sending end voltage.

$\vec{I}_s$  = the sending end current.

$\vec{V}_r$  = the receiving end voltage.

$\vec{I}_r$  = the receiving end current.

$\vec{Z}$  = series line impedance.

$\vec{Y}$  = shunt admittance of transmission line.

The two equations can be re-written in a matrix notation:

$$\begin{bmatrix} \vec{V}_s \\ \vec{I}_s \end{bmatrix} = \begin{bmatrix} 1 + \frac{\vec{Z}\vec{Y}}{2} & \vec{Z} \\ \vec{Y} + \frac{\vec{Z}\vec{Y}^2}{4} & 1 + \frac{\vec{Z}\vec{Y}}{2} \end{bmatrix} \begin{bmatrix} \vec{V}_r \\ \vec{I}_r \end{bmatrix} = \begin{bmatrix} A & B \\ C & D \end{bmatrix} \begin{bmatrix} \vec{V}_r \\ \vec{I}_r \end{bmatrix} \quad (3.3)$$

Where A, B, C and D called transmission parameters.

$$A = 1 + \frac{\vec{Z}\vec{Y}}{2} = D$$

$$B = \vec{Z}$$

$$C = \vec{Y} + \frac{\vec{Z}\vec{Y}^2}{4}$$

### 3.3 Symmetrical Component

Analysis of unbalanced three phase systems can be split into three balanced components, namely Positive Sequence (balanced and having the same phase sequence as the unbalanced supply), Negative Sequence (balanced and having the opposite phase sequence to the unbalanced supply) and Zero Sequence (balanced but having the same phase and hence no phase sequence). These are known as the Symmetrical Components or the Sequence Components and are shown in figure below:

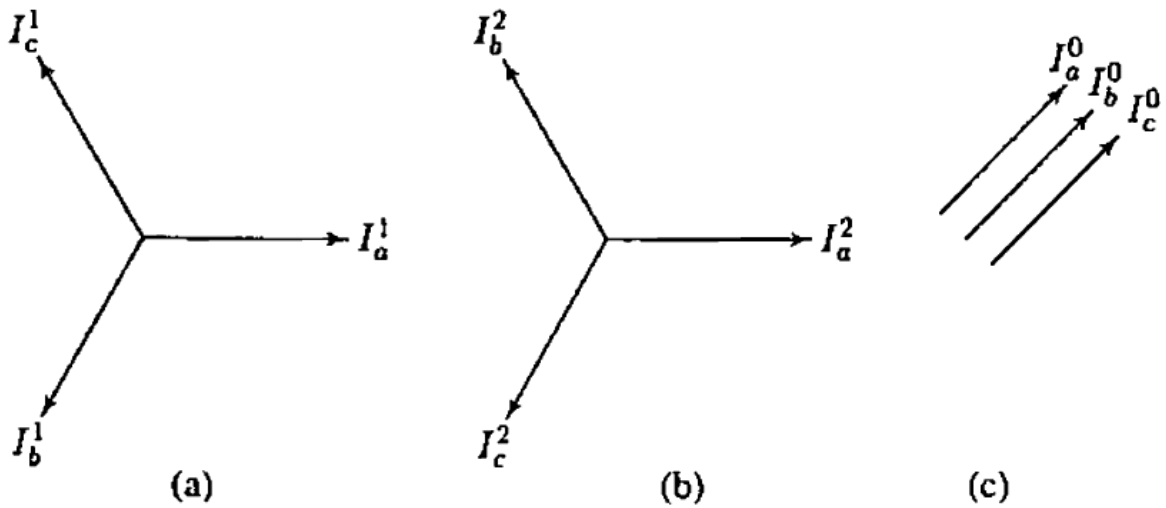

Figure (3.2): Representation of Symmetrical Component

(a) Positive sequence (b) Negative sequence (c) Zero sequence

According to the definition of the symmetrical components, the three- phase unbalanced currents  $I_a, I_b$  and  $I_c$  can be written in term of  $\alpha$  operator:

$$I_a = I_a^0 + I_a^1 + I_a^2 \quad (3.4)$$

$$I_b = I_b^0 + I_b^1 + I_b^2 = I_a^0 + \alpha^2 I_a^1 + \alpha I_a^2 \quad (3.5)$$

$$I_c = I_c^0 + I_c^1 + I_c^2 = I_a^0 + \alpha I_a^1 + \alpha^2 I_a^2 \quad (3.6)$$

To obtained the bus voltages and fault current during fault, for different types of fault as shown below:

### 3.3.1 Single Line-to-Ground Fault

This fault occurs on one phase through impedance  $Z_f$ . Assuming generator is initially on no load.

The fault current is:

$$I_a = 3I_a^0 = \frac{3E_a}{Z^1 + Z^2 + Z^0 + 3Z_f} \quad (3.7)$$

Where

$E_a$  = Phase voltage.

$Z^1$  = Positive sequence impedance.

$Z^2$  = Negative sequence impedance

$Z^0$  = Zero sequence impedance

$Z_f$  = Fault impedance.

### **3.3.2 Line-to-Line Fault**

This fault occur through an impedance  $Z_f$  between phase b and c, assuming the generator is initially on no load.

$$I_a^0 = 0 \quad (3.8)$$

$$I_a^1 = -I_a^2 \quad (3.9)$$

$$I_a^1 = \frac{E_a}{Z^1 + Z^2 + Z_f} \quad (3.10)$$

### **3.3.3 Double Line-to-Ground Fault**

This fault occur on phase b and c through an impedance  $Z_f$  to ground. Assuming the generator is initially on no load.

$$Ia^0 = -\frac{Ea - Z^1 Ia^1}{Z^0 + 3Zf} \quad (3.11)$$

$$Ia^2 = -\frac{Ea - Z^1 Ia^1}{Z^2} \quad (3.12)$$

$$Ia^1 = \frac{Ea}{Z^1 + \frac{Z^2(Z^0 + 3Zf)}{Z^2 + Z^0 + 3Zf}} \quad (3.13)$$

### 3.4 Fault Detection Techniques

Conventional fault detection algorithms are designed based on current or voltage magnitude measurements. Increase of current magnitude or decrease of voltage/impedance magnitude could be considered as a measure to detect a system fault. These algorithms are dependent on various factors such as fault resistance and power system short circuit capacity. Current based starters get confused when load current is significant compared to fault current. Conventional over current based starters may not be able to detect faults with high amount of fault resistance.

For remote low current faults, no clear under voltage condition arises at the relay location. In the case of a close-in fault on a weak system, all voltages deviate from the nominal value. Therefore, the voltage based starters might not be able to perform correctly for different fault conditions. For the conventional based fault detectors, current and voltage magnitudes should be estimated correctly using appropriate filtering algorithms. When a fault happens on a transmission line, the power system goes through a transient period. It might not be easy to determine current/voltage signal magnitude fast and precisely during the transient period after the occurrence of the fault. As power systems grow both in size and complexity, it becomes necessary to identify different system faults faster and more accurately using more powerful algorithms. It would be

desirable to design a reliable and fast algorithm to classify different power system faults for various system parameters and fault states.

### **3.4.1 Impedance Detection**

The impedance detection based its fault detection on the fact that the input impedance of a transmission line changes when a fault occurs. The magnitude of the impedance varies according to the location of the fault from the relay monitoring it, thus it is called distance relay. Distance relay does not to compare the measurement between two ends of protection zone as in overcurrent relays. Earlier systems use conventional method for the fault detection which results in the late detection and inaccurate results. Conventional algorithms are based on deterministic computations on a well-defined model for transmission line protection. Conventional distance relays consider power swing as a fault and tripping because of such malfunctioning would lead to serious consequences for power system stability. To improve the performance, Neural Network architecture is used which results in the earlier fault detection.

### **3.4.2 Intelligent based methods**

From quite a few years, intelligent based methods are being used in the process of fault detection. Three major artificial intelligence based techniques that have been widely used in the power and automation industry are:

- Expert System Techniques.
- Artificial Neural Networks.
- Fuzzy Logic Systems.

An adaptive neuro-fuzzy approach is used to develop an inference system for transmission line fault classification and location. It incorporates the effects of power swings. Fault location is done using wavelet-neuro-fuzzy combined approach. The wavelet transform captures the dynamic characteristics of fault signals using wavelet multi-resolution analysis (MRA) coefficients. The fuzzy inference system (FIS) and the adaptive-neuro-fuzzy inference system (ANFIS)

are both used to extract important features from wavelet MRA coefficients and thereby to reach conclusions regarding fault location. However, combination of different approaches makes the system complicated. This work uses ANN based approach which uses the fluctuations in current level as the key feature to detect faults. Neural network is capable of working with real time data and responds to the changes in surrounding environment immediately and this makes the system more flexible for the fault detection.

ANN based methods do not require a knowledge base for the detection of faults unlike the other artificial intelligence based methods. The prime motive behind this work is that a very accurate fault detector could make if employed in a power transmission and distribution system, in terms of the amount of money and Intelligent Fault Identification System for Transmission Lines Using Artificial Neural Network.

### **3.5 Fault Location Determination Technique**

The importance of power supply reliability is growing with the scale and complexity of electric power systems, and with the increasing use of communication devices and instruments. In modern ultrahigh-voltage transmission networks, a faulty line is identified and de-energized within two or three cycles after a fault occurs. This may seem very fast, but a device must withstand the heavy over current that flows during this period, which requires large size and capacity. Thus, faster fault location would contribute to simpler and more efficient transmission equipment.

The transmission line fault location process, as mentioned before, has been researched for a while and several innovative and efficient techniques have been proposed and analyzed by several authors. These techniques can be broadly classified as Impedance based methods, Travelling wave based methods and Artificial Intelligence based methods. Each of these methods is discussed briefly in the following subsections.

### 3.5.1 Impedance Based Method

In the case of Impedance based methods, the operation of the distance relay greatly relies on the fault resistance and is not successful in cases with very high fault resistance. Impedance based methods can be classified into single-ended methods and two-ended methods depending upon the number of terminals at which the voltage and current data are collected.

The basic logic behind a single-ended impedance based fault locator is to calculate the location of the fault from the apparent impedance seen looking into the line from one end. The various impedance based methods available in literature are discussed in the upcoming subsections.

### 3.5.2 Simple Reactance Method

The measured voltage and current values at the terminal are used to calculate the impedance of the line to the fault position as shown in equation (3.14). Once the line impedance per unit length has been determined, the fault distance can be calculated accordingly as illustrated by equations (3.15) and (3.16).

$$V_A = x \cdot Z_L \cdot I_A + V_f \quad (3.14)$$

Where

$V_A$  : is the voltage at terminal A,  $x$  is the distance to the fault from the terminal A,

$I_A$  : is the current flowing out of the terminal A,  $V_f$  is the fault voltage.

$Z_L$  : is the line impedance.

$$V_A = x \cdot Z_L \cdot I_A + R_f \cdot I_f \quad (3.15)$$

Where  $I_f$  is the fault current and  $R_f$  is the fault resistance as shown in Fig (3.1).

$$x = \frac{(V_A/I_A)}{Z_L} - \frac{R_f}{Z_L(I_A/I_f)} \quad (3.16)$$



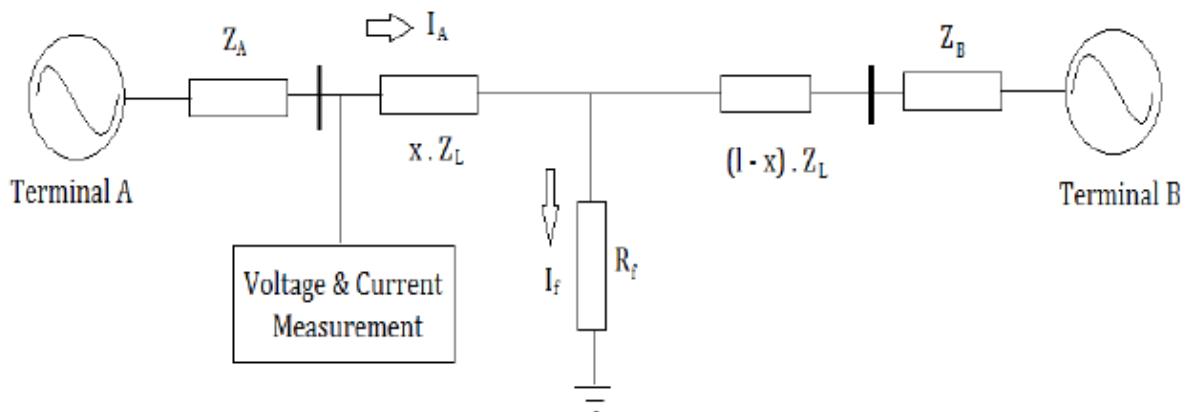

Figure (3.3): Faulted Transmission Line illustrating simple-reactance method

### 3.5.3 Takagi Method

The Takagi method is a very simple yet innovative single-ended impedance based Fault location technique. It requires both the pre-fault and fault data and enhances the simple reactance method by minimizing the effect of fault resistance and reducing the effect of load flow.

### 3.5.4 Modified Takagi Method

The modified Takagi method also called the Zero Sequence current method does not require pre-fault data because it uses zero-sequence current instead of the superposition current for ground faults.

### 3.5.5 Travelling Wave Based Method

Travelling wave based methods have been widely used for the purpose of fault location and are usually based on the correlation between the forward and backward waves travelling along the transmission line. The basic idea is to successively identify the fault initiated by high-frequency travelling waves at the fault locator.

### **3.5.6 Neural Networks Based Method**

Neural networks have been put in use for fault location quite recently and have gained significant importance. Wide usage of neural networks started by late eighties and during early nineties. Neural networks are usually used to achieve greater efficiency in fault detection, classification and location. A lot of research has been done and abundant literature has been published in the field of fault location using neural networks. Certain significant techniques and results that have been published are briefly discussed here. A majority of the work mentioned here made use of feed-forward multilayer perceptron technique. Kulicke and Dalstein used neural networks for the detection of faults on transmission lines and also differentiated between arcing and non-arcing faults. A new technique for the detection and location of high speed faults using neural networks has been proposed by Rikalo, Sobajic and Kezunovic. Neural network based single ended fault location techniques have been widely researched by Chen and Maun while Song used neural networks for fault location on series compensated lines.

## **3.6 Artificial Neural Network (ANNs)**

In this section, the neural network is defined, and the activation function is introduced. Then, different type of activation functions are presented.

### **3.6.1 Definition of Neural Networks:**

The Neural networks are defined as the systems of interconnected neurons. Neurons are the basic building blocks of brains which are the biological neural networks. The structure of Neuron is as shown below:

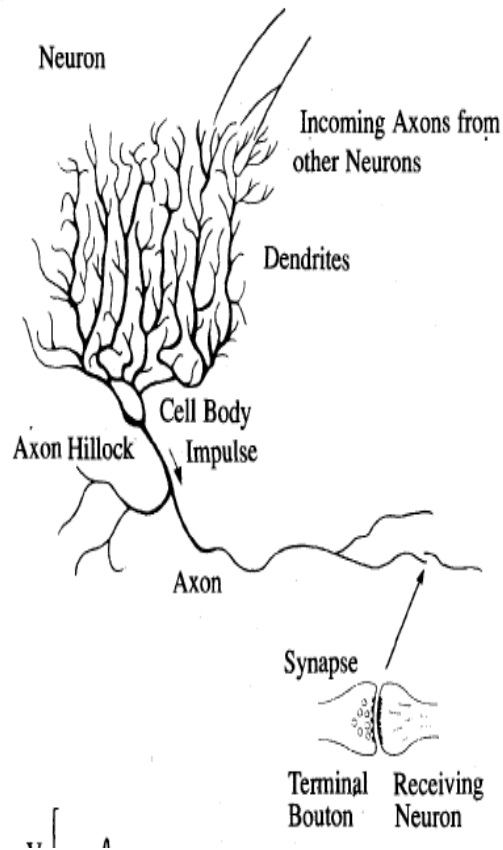

Figure (3.4): Schematic diagram of a neuron

Artificial Neural Networks are the computational tools which are modeled after brains. It is made up of an interconnected structure of artificially produced neurons that function as pathways for data transfer. Researchers are designing artificial neural networks (ANNs) to solve a variety of problems in pattern recognition, prediction, optimization, associative memory, and control. The simplest presentation of the artificial neural cell is a processing unit called perceptron as shown below:

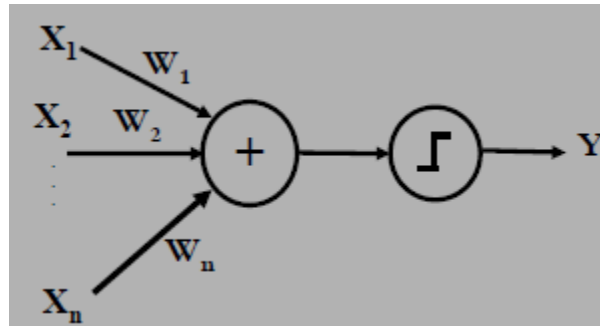

Figure (3.5): Representation of a Perceptron.

Neuron Output:

$$Y = f(\sum_{i=1}^n W_i X_i)$$

(3.17)

$$W = [w_1 \ w_2 \ \dots \ w_n]^t$$

(3.18)

$$X = [x_1 \ x_2 \ \dots \ x_n]^t$$

(3.19)

Where

$f$ =Activation function  $f$  (net).

### 3.6.2 Activation Function:

An activation function decides how powerful the output from the neuron should be, based on the sum of its inputs. Depending upon the application's requirements, the most appropriate activation function is chosen.

The activation function  $f(\varphi)$  can be in different forms a few of which are described below:

## Type of activation function:

### 1. Step function

$$f(\phi) = \begin{cases} 1 & \text{if } \phi \geq 0 \\ 0 & \text{if } \phi < 0 \end{cases}$$

(3.20)

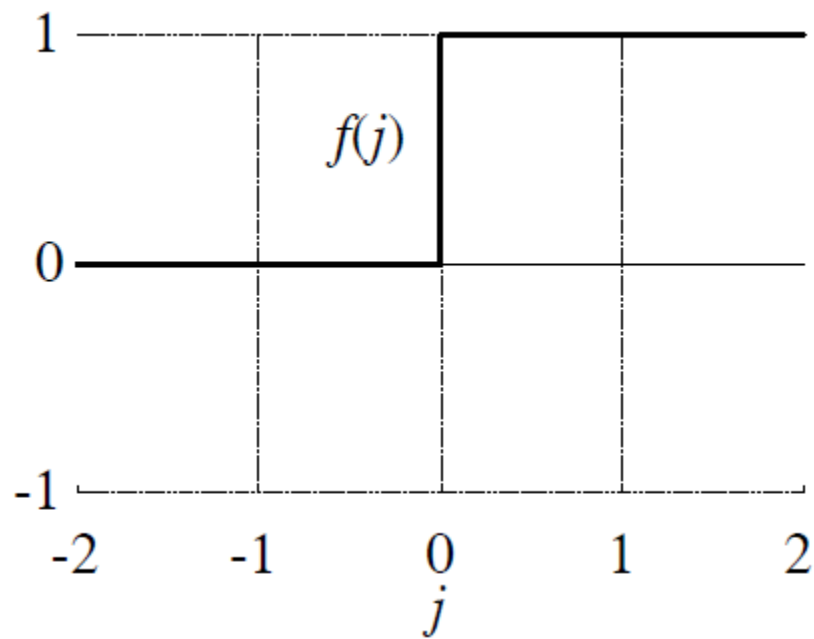

Figure (3.6): Step activation function

### 2. Linear function

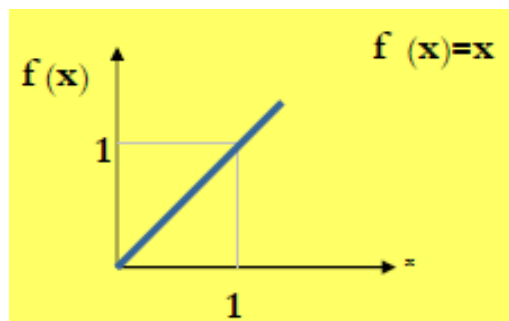

Figure (3.7): Linear activation function

### 3. Binary (Signum (sgn)):

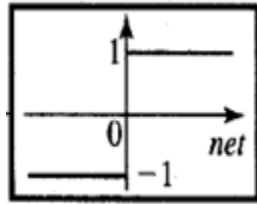

Figure (3.8): Binary activation function

$$f(\mathit{net}) = \mathit{sgn}(\mathit{net}) = \begin{cases} +1, & \mathit{net} > 0 \\ -1, & \mathit{net} < 0 \end{cases} \quad (3.21)$$

### 4. Sigmoid function

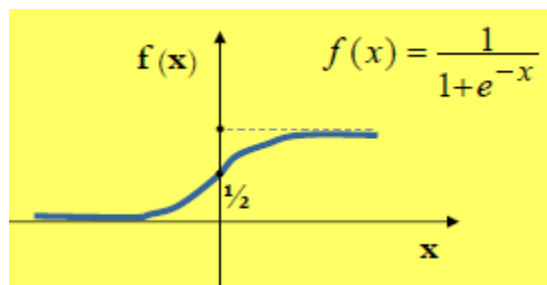

Figure (3.9): Sigmoid function

## 3.7 Type of Neural Networks

Based on the way the neurons are interconnected in a model, neural networks can be broadly classified into two types namely feedforward and feedback networks. As the name suggests, feedback networks unlike feedforward networks have a feedback connection fed back into the network along with the inputs. Due to their simplicity and the existence of a well-defined learning algorithm, only feedforward networks have been used in this project for the simulation.

### 3.7.1 Feedforward Network

Feedforward networks are the simplest neural networks where there is no feedback connection involved in the network and hence the information travel is unidirectional. A feedforward network with  $N_0$  input and  $K_R$  output signals is shown in Fig 3.7. The computation process in the  $i$ th layer can be described by the following equation

$$p^{(i)} = f^{(i)}(w^{(i)} \quad g^{(i-1)}) \quad (3.19)$$

Where

$$p^{(i)} = [p_1^{(i)} \quad p_2^{(i)} \quad \dots \quad p_N^{(i)}]^T \quad (3.20)$$

Equation (3.)Is the signal vector at the output of the  $i$ th layer.

$$\text{And } w^{(i)} = \begin{pmatrix} w_{10}^{(i)} & w_{11}^{(i)} & \dots & w_{1N_{i-1}}^{(i)} \\ w_{20}^{(i)} & w_{21}^{(i)} & \dots & w_{2N_{i-1}}^{(i)} \\ \vdots & \vdots & \ddots & \vdots \\ w_{N_i 0}^{(i)} & w_{N_i 1}^{(i)} & \dots & w_{N_i N_{i-1}}^{(i)} \end{pmatrix} \quad (3.21)$$

Equation (3.) Is the weighing matrix between the  $(i-1)$ th and the  $i$ th layer.

All the neurons in a particular layer are assumed to be similar in all aspects and the number of hidden layers can be more than one and is usually determined by the purpose of the neural network. The output of the processed neural network is represented by the output vector:

$$y = p^{(R)} = [y_1 \quad y_2 \quad \dots \quad y_{N_R}]^T \quad (3.22)$$

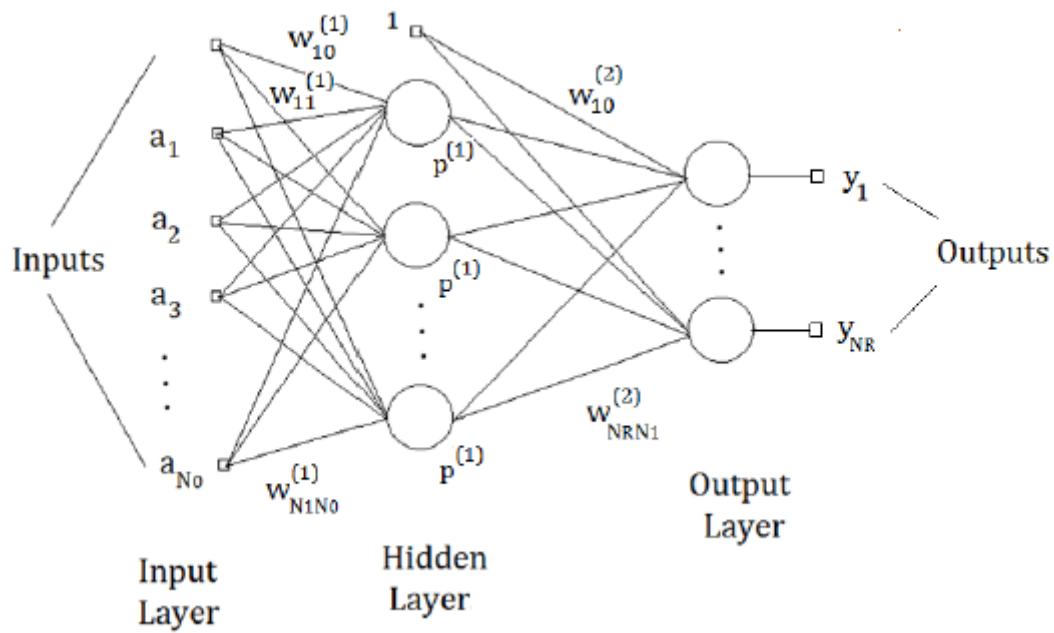

Figure (3.10): Structure of a two-layered feedforward network.

### 3.4.2 Feed-back Network

- A feedback network can be obtained from the feed-forward network by connecting the neurons' outputs to their inputs.
- The input  $x(t)$  is only needed to initialize this network so that  $o(0) = x(0)$ .
- The input is then removed and the system remains autonomous for  $t > 0$ .  $x(t) = x(0)$  and no input is provided to the network thereafter, or for  $t > 0$ .



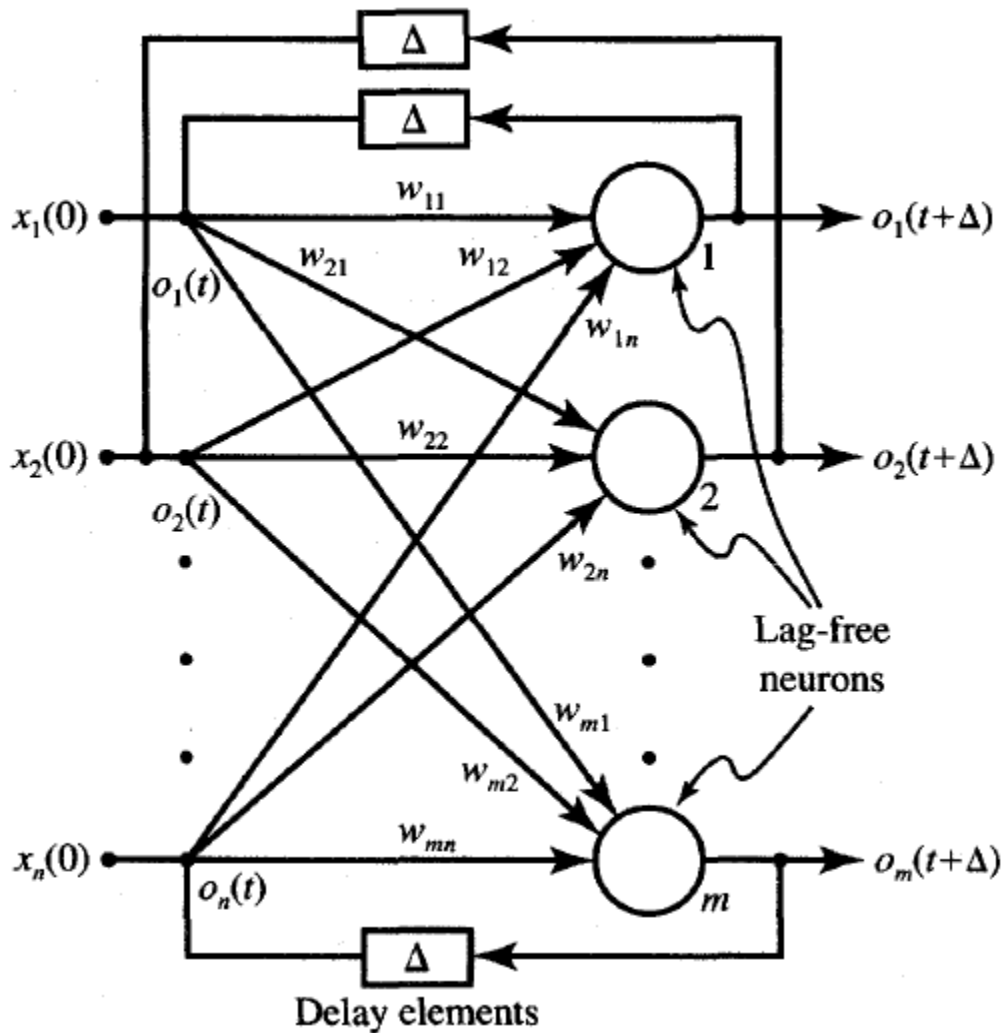

Figure (3.11): Representation of Feedback Network.

### 3.8 Learning Strategy

The basic concept behind the successful application of neural networks in any field is to determine the weights to achieve the desired target and this process is called learning or training. The two different learning mechanisms usually employed are supervised and unsupervised learning. In the case of supervised learning the network weights are modified with the prime objective of minimization of the error between a given set of inputs and their corresponding target value. Hence we know the training data set which is a set of inputs and the corresponding targets the neural network should output

ideally. This is called supervised learning because both the inputs and the expected target values are known prior to the training of ANN.

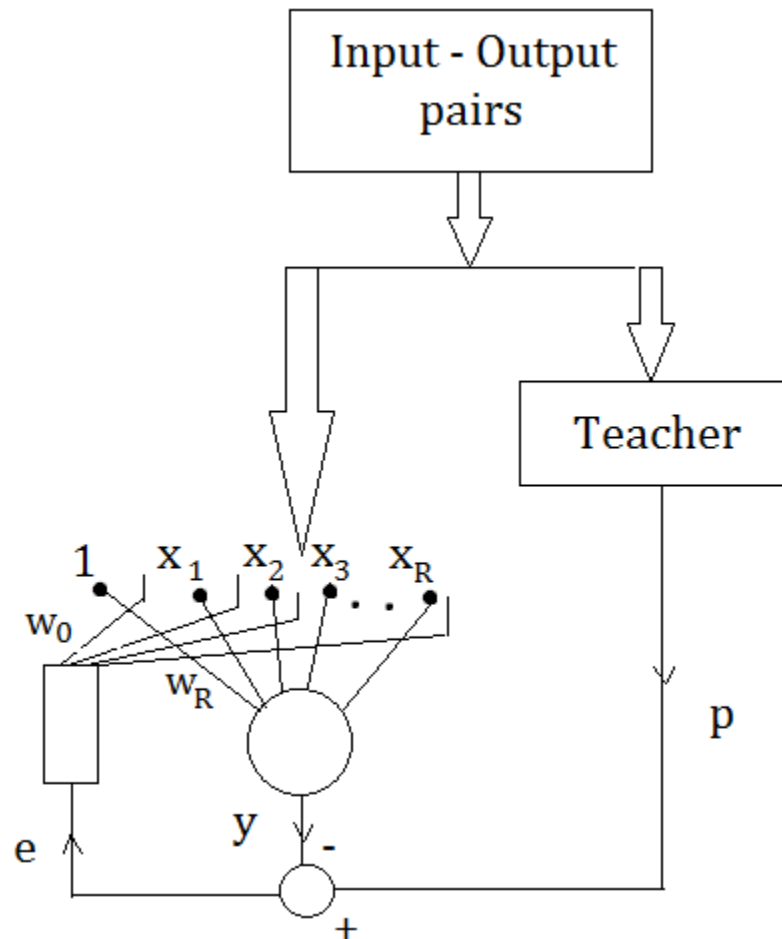

Figure (3.12): Scheme of supervised learning

### 3.8.1 Learning Rule:

An Artificial Neural Network is developed with a systematic step-by-step procedure with optimizes a criterion commonly known as the learning rule. The input/output training data is fundamental of these networks as it communicates the information that will be necessary to discover the optimal operating point. A non-linear nature of neural network make its processing elements flexible in their system.

An artificial neural network is a system and this system is a structure which receives an input, processes the data and provides an output. Once an input is presented to the neural network required target response is set at the output and from the difference of the desired response along with the output of real system an error is obtained. The error information is fed back to the system and it makes many adjustments to their parameters in a systematic order which is commonly known as the learning rule. This process is repeated until the desired output is accepted.

### **3.9 Advantages and Disadvantages of ANN**

In this section, advantages and disadvantages of the ANN are presented.

#### **3.9.1 Advantages of ANN:**

- A neural network can perform tasks in which a linear program cannot perform.
- When an element of the neural network fails, it can continue without any problem by their parallel nature.
- A neural network does not need to be reprogrammed as it learns itself.
- It can be implemented in any easy way without any problem.
- As adaptive, intelligent systems, neural networks are robust and excel at solving complex problems. Neural networks are efficient in their programming and the scientists agree that the advantage of using ANNs outweigh the risk.
- It can be implemented in any application.
- ANNs are flexible and adaptive.
- ANNs are used in sequence and pattern recognition systems, data processing, robotics, modeling, etc.

### **3.9.2 Disadvantages of ANN:**

- The neural network requires training to operate.
- Requires high processing time for large neural network.
- The architecture of a neural network is different from the architecture and history of microprocessors so they have to be emulated.

# **CHAPTER FOUR**

## **RESULTS AND DISCUSSION**

### **4.1 Introduction**

As discussed in the previous chapters, artificial neural networks have been used to aid for the protection of power transmission lines. The excellent pattern recognition and classification abilities of neural networks have been cleverly utilized in this project report to address the issue of transmission line fault location. This chapter presents a neural network-based approach for developing and implementing a complete scheme for distance protection of a transmission line system. In order to perform this goal, the distance protection problem is subdivided into different neural network models for fault detection, fault classification and fault location corresponding to different protection zones.

### **4.2 The Transmission Line under Study**

A 220 KV transmission line system studied as a sample which connects MASHKOR and JEBAL AWLIA (146.7 Km) is studied in this project. This transmission line is used to develop and implement the proposed architectures and algorithms for this problem, and demonstrate the work. The test system is shown in Figure (4.1). In the figure, zone 1 is 30 Km, zone2 is 60 Km, zone3 is 90 Km and zone4 is 120Km from the source. More detailed information regarding to the transmission line parameters are presented in the Appendix.

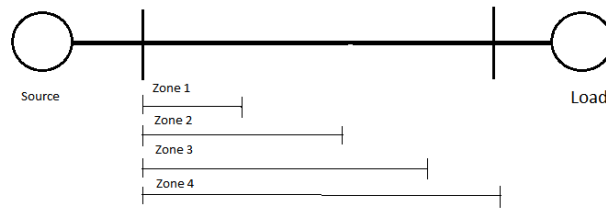

Figure (4.1): A single line diagram of transmission line.

This above single line diagram was modeled by using MATLAB2014a. The line has been modeled using distributed parameters so that it more accurately describes a very long transmission line. The three-phase voltages and currents  $V = [V_a \ V_b \ V_c]^T$  , and  $I = [I_a \ I_b \ I_c]^T$  are measured by using V-I measurement. The transmission line is divided into two lines line 1 & line 2 each line is 73.35 Km long. Model of three phase fault simulator is used to simulate various types of fault. In the subsequent simulation results we consider the following four categories, namely

- (i) Phase to ground faults.
- (ii) Phase to phase faults.
- (iii) Double phase to ground faults.
- (iv) Three-phase fault

The model of the three phase transmission line is shown in figure (4.2) below:

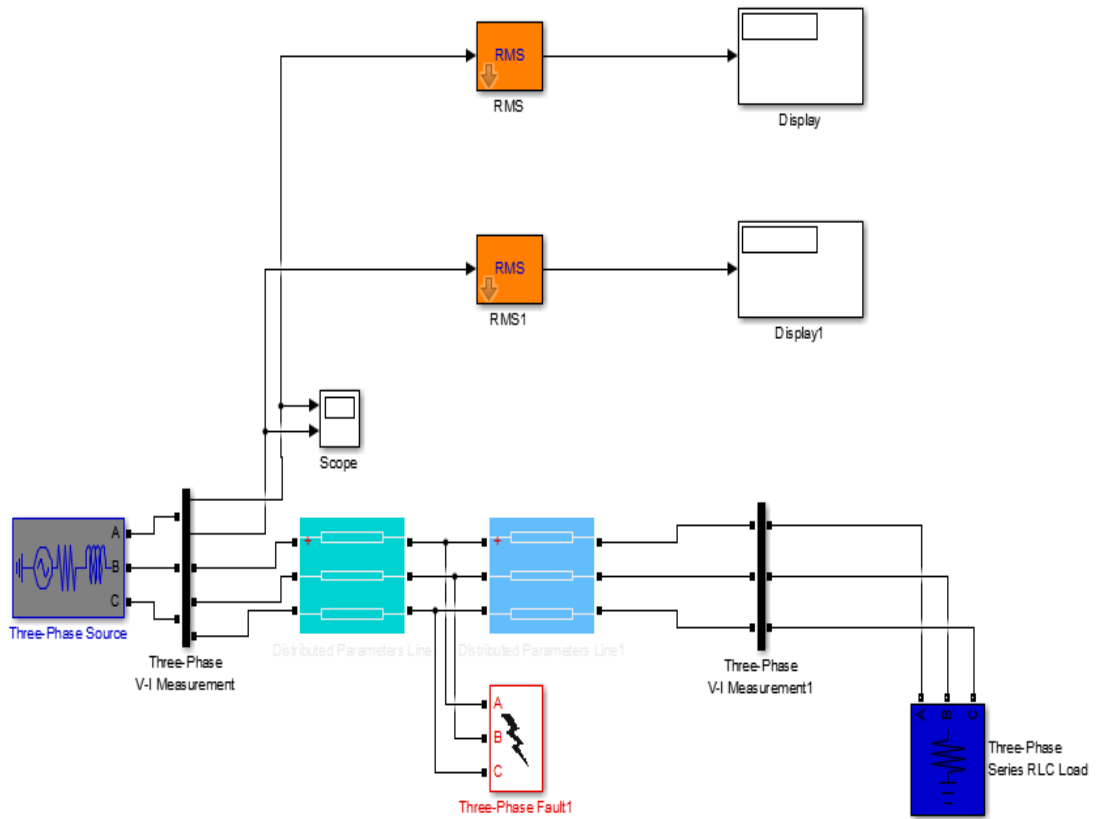

Figure (4.2): Three Phase Test System Model in MATLAB/SIMULINK.

The data set required for training the neural networks developed below is generated from various fault situations considering different fault locations by using MATLAB/SIMULINK as shown in details in tables (4.1), (4.2), (4.3), (4.4) and (4.5):

Table (4.1): Voltage and Current results for various fault cases far of 15 Km from the source:

Type of fault	V a (KV)	V b (KV)	V c (KV)	I a (A)	I b (A)	I c (A)
Normal	127.5	127.5	127.5	302.53	302.53	302.53
A-G	56.25	127.2	127.6	13410.7	280	358.7
B-G	127.6	56.25	127.2	358.9	13410.7	280
C-G	127.2	127.6	56.25	280	358.9	1310.7
AB	72.7	71	127.5	14612.9	14322.8	302.6
BC	127.5	72.7	71	302.6	14612.9	14322.8
AC	71	127.5	72.7	14322.8	302.6	14612.9
AB-G	47.5	48	127.3	15704.7	15314.9	330
BC-G	127.3	47.5	48	330	15704.7	15314.9
AC-G	48	127.3	47.5	15314.9	330	15704.7
ABC	38.8	38.8	38.8	16705	16705	16705

From the above values of the Table (4.1), in case of a single line-to-ground fault, the value of the current at faulty phase was a larger than its nominal value and its voltage value was small. In case of line-to-line fault, value of the current at faulty phases were equally and large when comparing to other phase. The



voltage values of the faulty phases were equally in magnitude and take a minimum value.

Table (4.2): Voltage and Current results for various fault cases far of 30 Km from the source:

Type of fault	V a (KV)	V b (KV)	V c (KV)	I a (A)	I b (A)	I c (A)
Normal	127.5	127.5	127.5	302.53	302.53	302.53
A-G	77.9	127.11	127.7	9300.56	289.65	374.15
B-G	127.7	77.9	127.11	374.15	9300.56	289.65
C-G	127.11	127.7	77.9	289.65	374.15	9300.56
AB	82.484	81.36	127.5	11230	10939	302.5
BC	127.5	82.48	81.36	302.5	11230	10939
AC	81.36	127.5	82.48	10939	302.5	11230
AB-G	67.7	68.13	127.4	11845	11487	334.9
BC-G	127.4	67.7	68.13	344.9	11845	11487
AC-G	68.13	127.4	67.7	11487	344.9	11845
ABC	59.4	59.4	59.4	12799	12799	12799

Table (4.3): Voltage and Current results for various fault cases far of 60 Km from the source.

Type of fault	V a (KV)	V b (KV)	V c (KV)	I a (A)	I b (A)	I c (A)
Normal	127.5	127.5	127.5	302.53	302.53	302.53
A-G	96.67	127.03	127.78	5765.9	298.9	387.7
B-G	127.78	96.67	127.03	387.7	5765.9	298.7
C-C	127.3	127.78	96.67	298.9	387.7	5765.9
AB	95.06	94.5	127.5	7693.5	7401.9	302.59
BC	127.5	95.06	94.5	302.59	7693.5	7401.9
AC	127.5	95.06	94.5	7401.09	302.05	7693.5
AB-G	87.26	87.68	127.4	7997	7691	356.6
BC-G	127.4	87.26	87.68	356.6	7997	7691
AC-G	87.68	127.4	87.26	7691	356.6	7997
ABC	80.99	80.99	80.99	8715	8715	8715

Table (4.4): Voltage and Current results for various fault cases far of 90 Km from the source.

Type of fault	V a (KV)	V b (V)	V c (V)	I a (A)	I b (A)	I c (A)
Normal	127.5	127.5	127.5	302.53	302.53	302.53
A-G	105.07	126.99	127.8	4177	303.6	394.12
B-G	127.8	105.07	126.99	394.12	4177	303.6
C-C	126.99	127.8	105.07	303.6	394.12	4177
AB	102.23	102.07	127.5	5861.6	5569.7	302.6
BC	127.5	102.23	102.07	302.6	5861.6	5569.7
AC	102.07	127.5	102.23	5569.7	302.6	5861.6
AB-G	97.02	97.02	127.4	6051	5771	361.87
BC-G	127.4	97.5	97.5	361.87	6051	5771
AC-G	97.5	127.4	79.02	5771	361.87	6051
ABC	92	92	92	6599.6	6599.6	6599.6

Table (4.5): Voltage and Current results for various fault cases far of 120 Km from the source.

Type of fault	V a (KV)	V b (KV)	V c (KV)	I a (A)	I b (A)	I c (A)
Normal	127.5	127.5	127.5	302.53	302.53	302.53
A-G	109.8	126.9	127.8	3273.2	306.5	398.04
B-G	127.8	109.8	126.9	398.04	3273.2	306.5
C-C	126.9	127.8	109.8	306.5	398.04	3273.2
AB	106.9	106.9	127.5	4739	4447	302.6
BC	127.5	106.8	106.9	302.6	4739	4447
AC	106.9	127.5	106.8	4447	302.6	4739
AB-G	102.9	103.5	127.4	4871	4604.9	365.1
BC-G	127.4	102.9	103.5	365.1	4871	4604.9
AC-G	103.5	127.4	102.9	4604.9	365.1	4871
ABC	99	99	99	5303.5	5303.5	5303.5

It was clearly show that the value of the current reduce when the fault occurs far from the source.

The following waveforms show the currents waveform at various cases:

Note that, the measured values that listed in above tables are represented the Vrms value and the value from the plot is a line value.

The current waveform at normal condition on transmission line:

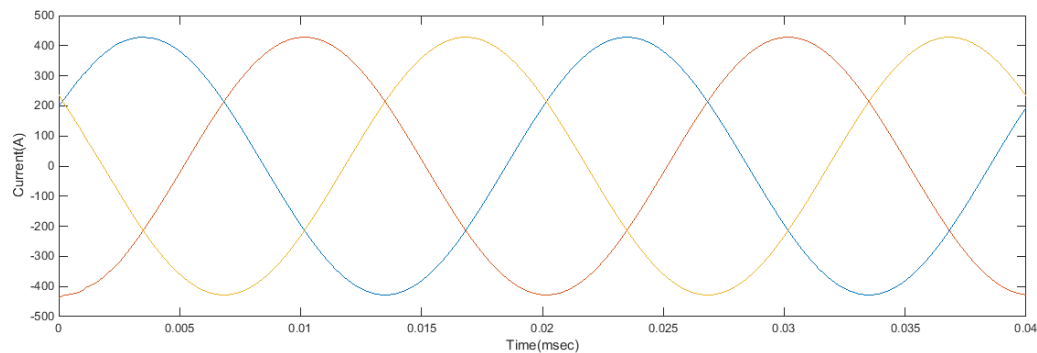

Figure (4.3): Current waveforms at normal condition

As seen from above figure, the value of currents (greater than 400 A) was taken from the scope but the value in the table (302.5 A) describe the momentary value of it.

And at the single line-to-ground fault, the current waveforms are shown below:

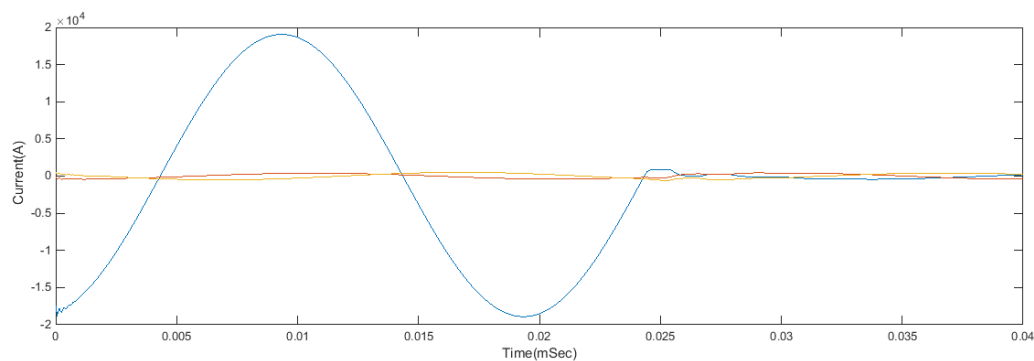

Figure (4.4): Current waveforms at single line-to-ground fault.

From above figure, and when a single line-to-ground fault occurs the value of the current at these phase became greater than of normal condition value. From the scope, the faulty current value is (13410.7A), and its momentary value is greater than (15000 A).

And at the line-to-line fault, the current waveforms are shown below:

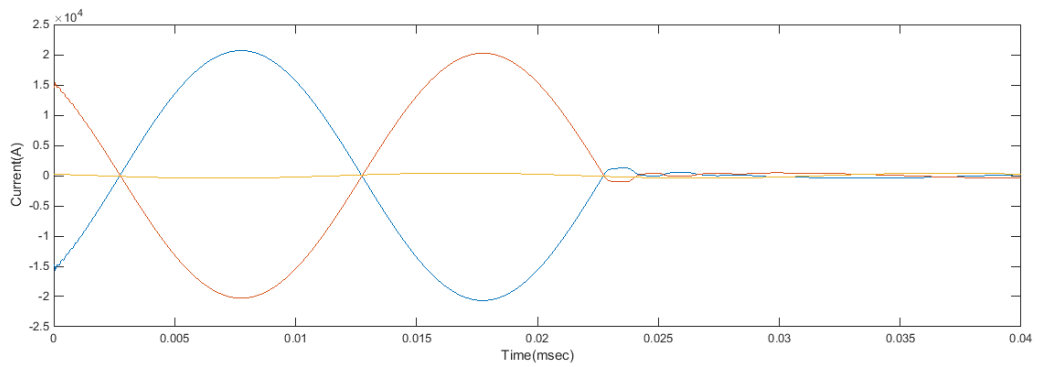

Figure (4.5): Current waveforms at line-to-line fault

And from figure, when double line fault occurs the fault current value was became (14612.9 A), and the momentary value is less than (20000 A).

And at the double line-to-ground fault, the current waveforms are shown below:

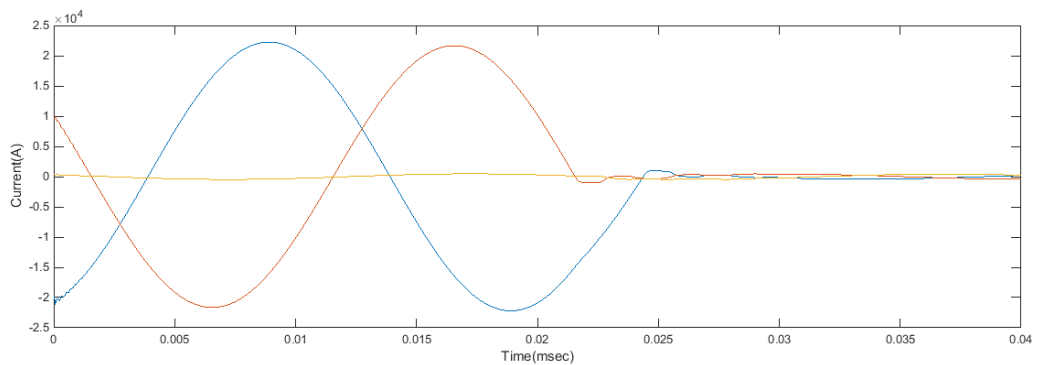

Figure (4.6): Current waveforms at double line-to-ground fault.

From above figure, and when a double line-to-ground fault occurs the value of the faulty current from the scope is (15704.7A), and its momentary value is greater than (20000 A).

And at the double line-to-ground fault, the current waveforms are shown below:

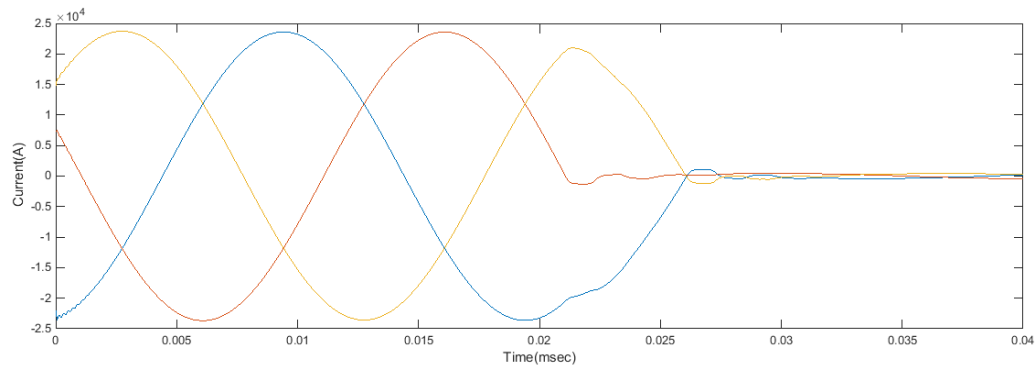

Figure (4.7): Current waveforms at three line fault.

From above figure, when double line-to-ground fault occurs the fault current value was became (16706 A), and the momentary value is less than (25000 A).

### 4.3 Overview of the Training Process

Two important steps in the application of neural networks for any purpose are training and testing. The first of the two steps namely training the neural network is discussed in this section. Training is the process by which the neural network learns from the inputs and updates its weights accordingly. In order to train the neural network we need a set of data called the training data set which is a set of input output pairs fed into the neural network. Thereby, we teach the neural network what the output should be, when that particular input is fed into it. The ANN slowly learns the training set and slowly develops an ability to generalize upon this data and will eventually be able to produce an output when a new data is provided to it. During the training process, the neural network's weights are updated with the prime goal of minimizing the performance function. This performance function can be user defined, but usually feedforward networks employ Mean Square Error as the performance function and the same is adopted throughout this work.

As already mentioned in the previous chapter, all the voltages and currents fed into the neural network are scaled with respect to the corresponding voltage and current values before the occurrence of the fault. The outputs, depending upon the purpose of the neural network might be the fault condition, the type of fault or the location of the fault on the transmission line. For the task of training the neural networks for different stages, sequential feeding of input and output pair has been adopted.

#### **4.4 Overview of the Testing Process**

As already mentioned in the previous section, the next important step to be performed before the application of neural networks is to test the trained neural network. Testing the artificial neural network is very important in order to make sure the trained network can generalize well and produce desired outputs when new data is presented to it.

There are several techniques used to test the performance of a trained network, a few of which are discussed in this section. One such technique is to plot the best linear regression fit between the actual neural network's outputs and the desired targets.

Analyzing the slope of this line gives us an idea on the training process. Ideally the slope should be 1. Also, the correlation coefficient ( $r$ ), of the outputs and the targets measures how well the ANN's outputs track the desired targets. The closer the value of ' $r$ ' is, to 1, the better the performance of the neural network. Another technique employed to test the neural network is to plot the confusion matrix and look at the actual number of cases that have been classified positively by the neural network. Ideally this percentage is a 100 which means there has been no confusion in the classification process. Hence if the confusion matrix indicates very low positive classification rates, it indicates that the neural network might not perform well. The last and a very obvious means of testing



the neural network is to present it with a whole new set of data with known inputs and targets and calculate the percentage error in the neural networks output. If the average percentage error in the ANN's output is acceptable, the neural network has passed the test and can be readily applied for future use.

The Neural Network toolbox in Simulink by The MathWorks divides the entire set of data provided to it into three different sets namely the training set, validation set and the testing set. The training data set as indicated above is used to train the network by computing the gradient and updating the network weights. The validation set is provided during to the network during the training process (just the inputs without the outputs) and the error in validation data set is monitored throughout the training process. When the network starts overfitting the data, the validation errors increase and when the number of validation fails increase beyond a particular value, the training process stops to avoid further overfitting the data and the network is returned at the minimum number of validation errors. The test set is not used during the training process but is used to test the performance of the trained network. If the test set reaches the minimum value of MSE at a significantly different iteration than the validation set, then the neural network will not be able to provide satisfactory performance.

## **4.5 Fault Detection**

For the purpose of fault detection, various topologies of Multi-Layer Perceptron have been studied. The various factors that play a role in deciding the ideal topology are the network size, the learning strategy employed and the training data set size. After an exhaustive study, the back-propagation algorithm has been decided as the ideal topology. Even though the basic back-propagation algorithm is relatively slow due to the small learning rates employed, few techniques can significantly enhance the performance of the algorithm. One

such strategy is to use the Levenberg-Marquardt optimization technique. The selection of the apt network size is very vital because this not only reduces the training time but also greatly enhance the ability of the neural network to represent the problem in hand. Unfortunately there is no thumb rule that can dictate the number of hidden layers and the number of neurons per hidden layer in a given problem.

#### **4.5.1 Training the Fault Detection Neural Network**

In the first stage which is the fault detection phase, the network takes in six inputs at a time, which are the voltages and currents for all the three phases (scaled with respect to the pre-fault values) for ten different faults and also no-fault case. Hence the training set consisted of about 88 input output sets faults with a set of six inputs and one output in each input-output pair. The output of the neural network is just a yes or a no (1 or 0) depending on whether or not a fault has been detected. After extensive simulations it has been decided that the desired network has one hidden layer with 10 neurons in the hidden layer.

Fig 4.8 shows the training performance plot of the neural network 6-10-1 (6 neurons in the input layer, 1 hidden layer with ten neurons in it and one neuron in the output layer).

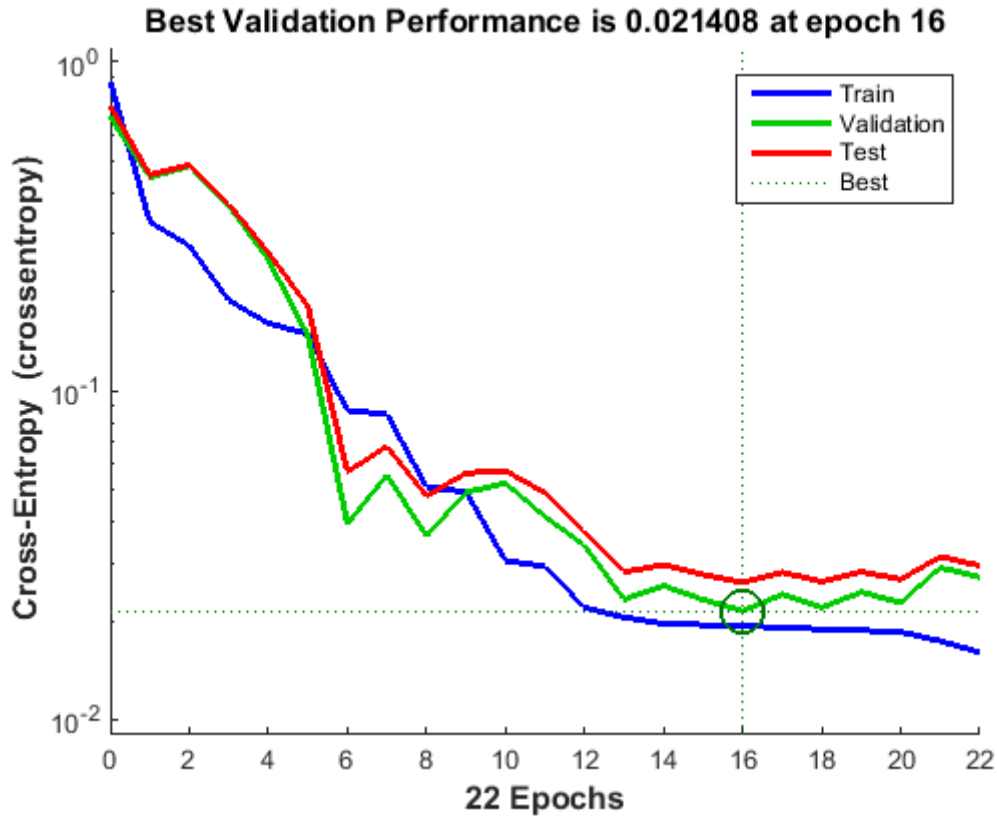

Figure (4.8): Plot of the training performance the neural network 6-10-1.

From the figure above, and after training the network for more time, it observes that the best performance is 0.021408 occurs at epoch 16.

### 4.5.2 Testing of the Fault Detection Neural Network

Once the neural network has been trained, its performance has been tested by plot the confusion matrices for the various types of errors that occurred for the trained neural network. Fig 4.9 plots the confusion matrix for the three phases of training, testing and validation. The diagonal cells in green indicate the number of cases that have been classified correctly by the neural network and the off-diagonal cells which are in red indicate the number of cases that have been wrongly classified by the ANN. The last cell in blue in each of the matrices indicates the total percentage of cases that have been classified

correctly in green and the vice-verca in red. It can be seen that the chosen neural network has 100 percent accuracy in fault detection.



Figure (4.9): Confusion matrices for Training, Testing and Validation Phases.

It can be seen that the chosen neural network has 100 percent accuracy in fault detection.

## 4.6 Fault Classification

Once a fault has been detected on the power line, the next step is to identify the type of fault. This section presents an analysis on the fault classification phase using neural networks. A review of the different neural networks that

were analyzed is provided which is followed by the chosen network. Fault classifiers based on neural networks have been extensively proposed and used in the past and almost all of these classifiers made use of multilayer perceptron neural network and employed the back-propagation learning strategy. Although backpropagation learning strategy is inherently slow in learning and poses difficulty in choosing the optimal size of the network, it is undoubtedly the ideal strategy to be employed when there is a large training set available because back-propagation algorithm can provide a very compact distributed representation of complex data sets.

#### **4.6.1 Training the Fault Classifier Neural Network**

The same process that was employed in the previous section (section 4.4) is also followed in this section in terms of the design and development of the classifier neural network. The designed network takes in sets of six inputs (the three phase voltage and current values scaled with respect to their corresponding pre-fault values). The neural network has four outputs, each of them corresponding to the fault condition of each of the three phases and one output for the ground line. Hence the outputs are either a 0 or 1 denoting the absence or presence of a fault on the corresponding line (A, B, C or G where A, B and C denote the three phases of the transmission line and G denotes the ground). Hence the various possible permutations can represent each of the various faults accordingly. The proposed neural network should be able to accurately distinguish between the ten possible categories of faults. The truth table representing the faults and the ideal output for each of the faults is illustrated in Table 4.5.

Table (4.5) Fault classifier ANN outputs for various faults.

Type of Fault	A	B	C	G
No Fault	0	0	0	0
A-G Fault	1	0	0	1
B-G Fault	0	1	0	1
C-G Fault	0	0	1	1
A-B Fault	1	1	0	0
B-C Fault	0	1	1	0
A-C Fault	1	0	1	0
A-B-G Fault	1	1	0	1
B-C-G Fault	0	1	1	1
A-C-G Fault	1	0	1	1
A-B-C Fault	1	1	1	0

Hence the training set consisted of about 88 input output sets with a set of six inputs and one output in each input-output pair. Back-propagation networks with a variety of combinations of hidden layers and the number of neurons per hidden layer have been analyzed. Of these, the ones that achieved satisfactory performance are shown followed by the best neural network which has been described further in detail. Figures 4.10 show the performance plots of neural networks with 1 hidden layers.

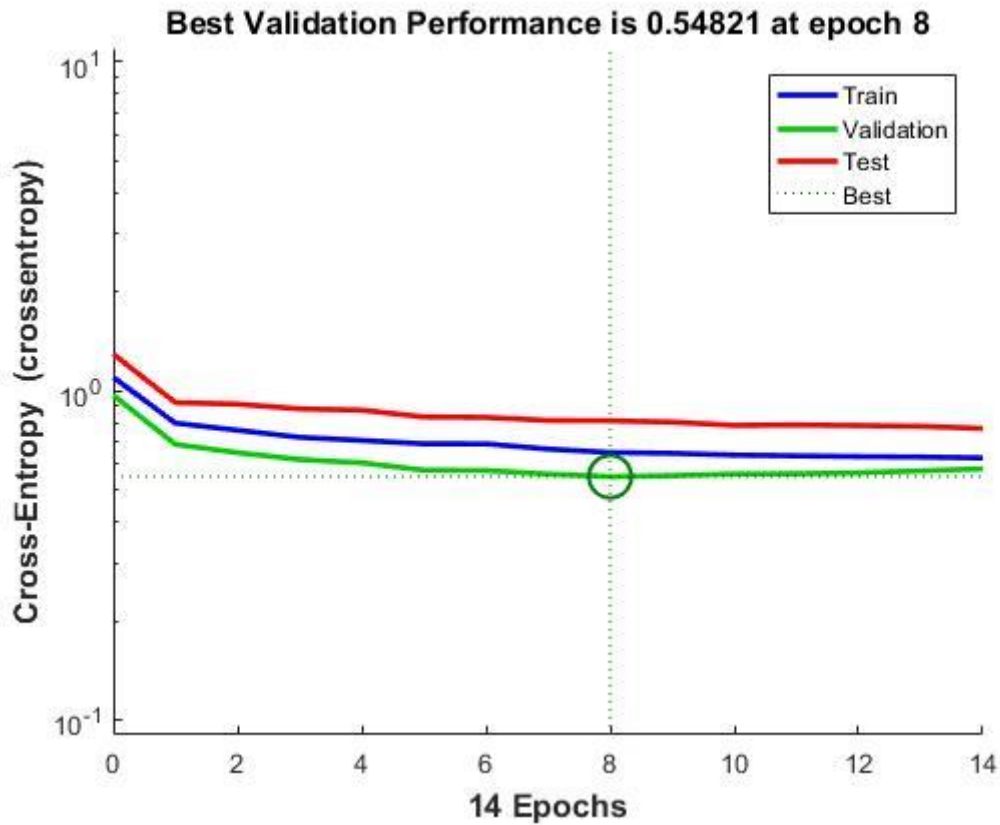

Figure (4.10): Performance plot of one hidden layer.

From the figure above, and after training the network for more time, it observes that the performance is 0.54821 occurs at epoch 8.

#### 4.6.2 The testing process of classifier

The testing process of classifier data set is to plot the Receiver Operating Characteristics curve (ROC). The ROC curves for each of the training, testing and validation phases have been shown in Fig 4.11 along with the overall ROC curve. The ROC curves are actually plots between the true positive rates (rate of positive classification) and the false positive rates (rate of incorrect classification) of the neural network classifier.

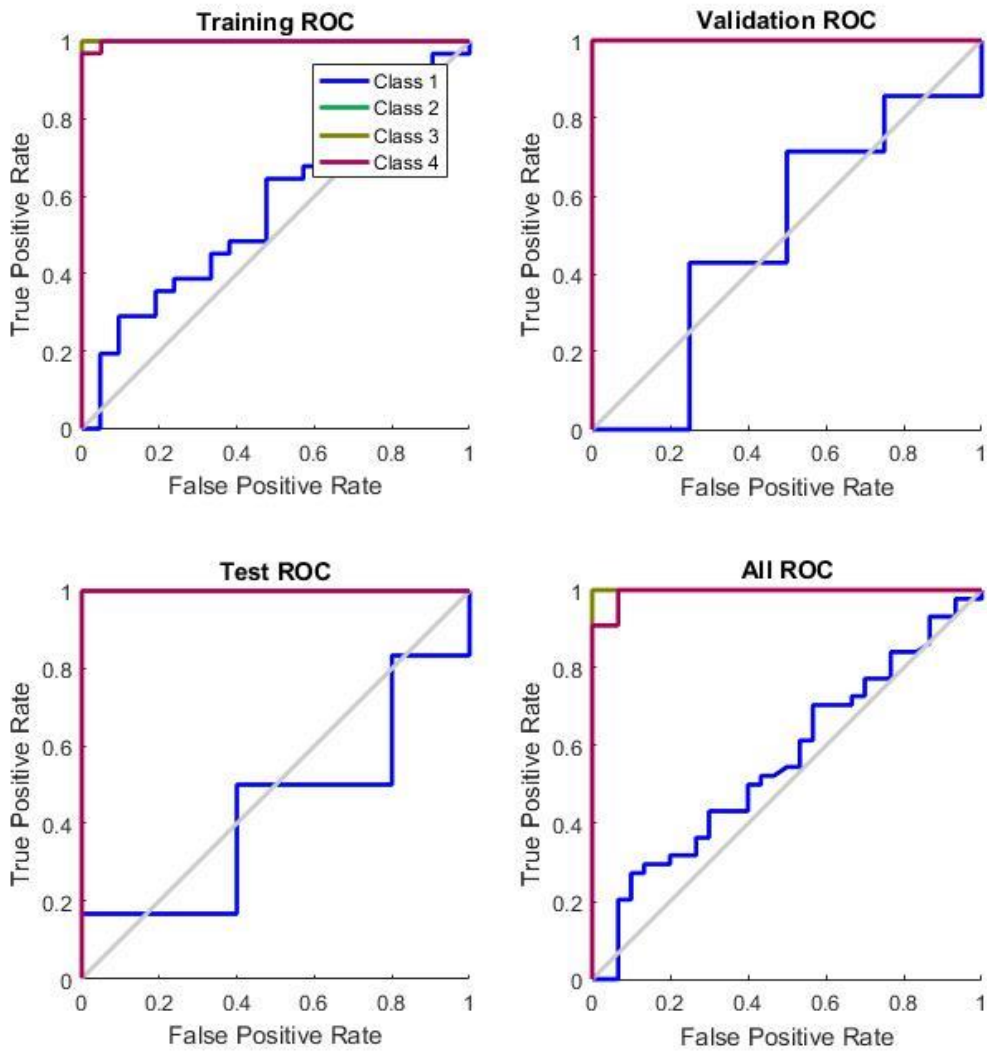

Fig (4.11): The Receiver Operating Characteristics curve (ROC).

It is to be noted that from the ROC curves plotted in Fig (4.11), the test of the data set didn't classify carefully. It will be perfect classification when it has a large number of samples.

## 4.7 Fault Location

Detection of fault location has to be done for the purpose of isolating the faulty section of the system.

The network is expected to identify the location of the fault by classifying the identified fault into one of the three fault zones, namely Zone 1, 2, 3 and 4. The



proposed neural networks here should isolate the specific zone involved in the fault network as shown in the network training Table (4.6)

Table (4.6): Isolation NN Training Set

Fault Location	Z1	Z2	Z3	Z4
Zone 1	1	0	0	0
Zone 2	0	1	0	0
Zone 3	0	0	1	0
Zone 4	0	0	0	1

The data of the zones fed into the neural, and after the classification ended the performance of the network is become 0.26792 at epoch 1 as shown in figure 4.12. It noted that when train the network more, the performance will be more accurate.

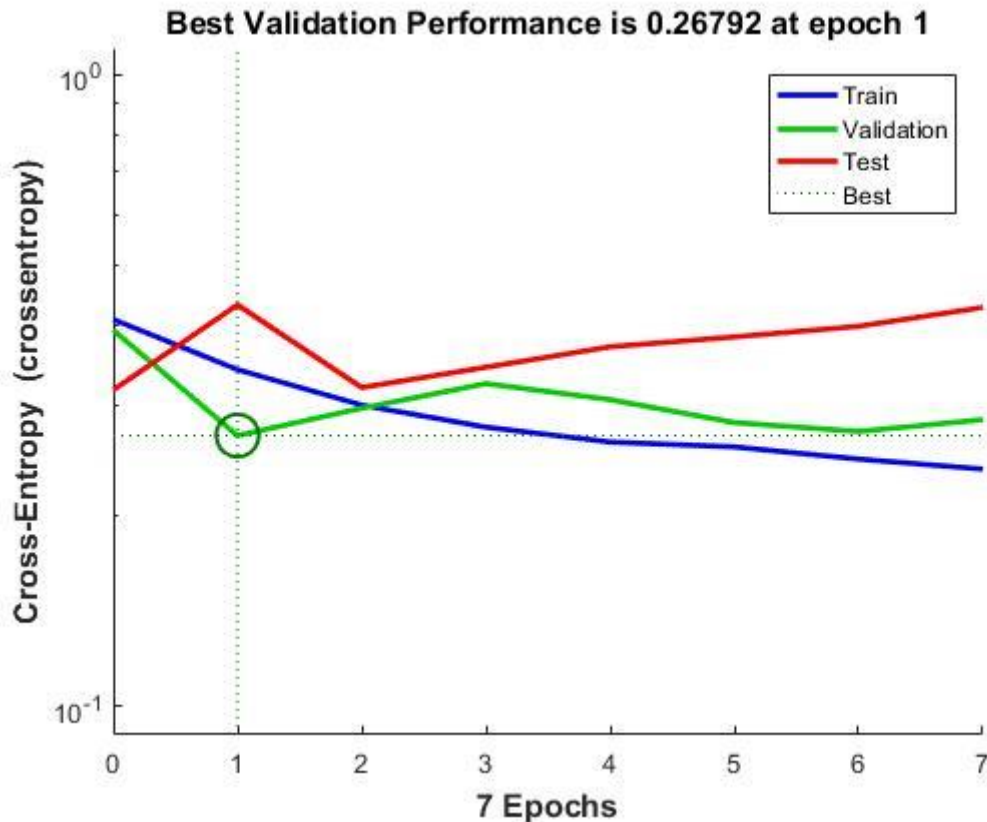

Figure (4.12): Performance plot of the location of the network.

From the figure above, and after training the network for more time, it observes that the performance is 0.26792 occurs at epoch 1.

For the test purpose of the network by using the real values for the case of fault, and when the voltages and currents inputs [56.25, 127.2, 127.6, 13410.7, 280, 358.9] were fed into the neural network, the output result was 0.9987.

And for case of normal condition, when the voltages and currents inputs [127.5, 127.5, 127.5, 302.5, 302.5, 302.5] were fed into the neural network, the output result was 0.05

In order to obtain a large training set for efficient performance, each of the ten kinds of faults has been simulated at different locations along the considered transmission line. In view of all these issues, about 100 different fault cases for each of the 10 kinds of faults have been simulated.

# **CHAPTER FIVE**

## **CONCLUSION AND RECOMMENDATIONS**

### **5.1 Conclusion**

This research has studied usage of back propagation neural networks as an alternative method for detection, classification and determination of location of faults on transmission lines. Value of RMS phase voltages and phase currents are used as inputs to the neural networks. Various possible kinds of faults namely single line-ground, line-line, double line-ground and three phase faults have been taken into consideration into this work and separate ANNs have been proposed for each of these faults. Depending on the application of the neural network and the size of the training data set, the size of the ANN (the number of hidden layers and number of neurons per hidden layer) keeps varying.

MATLAB R2014a has been used along with the SimPowerSystems toolbox in Simulink have been used to simulate the power transmission line model and to obtain the training data set, the Artificial Neural Networks ToolBox has been used to train and analyze the performance of the neural network.

Due to the flexibility of ANNs which accept any real values (highly correlated) as an input, resistant to errors in the training data and fast evaluation the results obtained was highly satisfactory. ANNs provide a reliable and an attractive alternative approach for the development of a protection relaying system for the power transmission system.

## **5.2 Recommendations**

1. It would be useful to convert all the neural networks proposed for the three tasks of fault detection, classification and location in to a single program.
2. Implementation of the proposed networks as part of a real-time control for the protection of power transmission systems.
3. This research concentrated on the back-propagation neural network (BP) architecture. The study of other neural network architectures might be considered useful in future.

## REFERENCES

- [1] Das R, Novosel D, “Review of fault location techniques for transmission and sub – transmission lines”. Proceedings of 54th Annual Georgia Tech Protective Relaying Conference, 2000.
- [2] IEEE guide for determining fault location on AC transmission and distribution lines. IEEE Power Engineering Society Publ., New York, IEEE Std C37.114, 2005.
- [3] Saha MM, Das R, Verho P, Novosel D, “Review of fault location techniques for distribution systems”, Proceedings of Power Systems and Communications Infrastructure for the Future Conference, Beijing, 2002, 6p.
- [4] Eriksson L, Saha MM, Rockefeller GD, “An accurate fault locator with compensation for apparent reactance in the fault resistance resulting from remote-end feed”, IEEE Trans on PAS 104(2), 1985, pp. 424-436.
- [5] Saha MM, Izykowski J, Rosolowski E, Fault Location on Power Networks, Springer publications, 2010.
- [6] Magnago FH, Abur A, “Advanced techniques for transmission and distribution system fault location”, Proceedings of CIGRE – Study committee 34 Colloquium and Meeting, Florence, 1999, paper 215.
- [7] Tang Y, Wang HF, Aggarwal RK et al., “Fault indicators in transmission and distribution systems”, Proceedings of International conference on Electric Utility Deregulation and Restructuring and Power Technologies – DRPT, 2000, pp. 238-243.
- [8] hagan MT, Demuth HB, Beale MH, “Neural network design”, PWS publishing, 1996.

[9] kevin Gurney, “An Introduction to neural networks” UCL press, 1997.

# APPENDIX

## Transmission line parameters Data

No.	from	to	length km	Type Towers	no.of circuit	conductor type & size	nominal voltage kV	R1 $\Omega$ /km)	X1 ( $\Omega$ /km)
55	mushkur	jebel aulia	146.72		2	2*240mm <sup>2</sup> ACSR	220	0.067	0.302
56	mushkur	rabak	106.31		2	2*240mm <sup>2</sup> ACSR	220	0.067	0.302
57	rank	roseires	172.54		2	2*240mm <sup>2</sup> ACSR	220	0.067	0.302
58	rabak	rank	163.46		2	2*240mm <sup>2</sup> ACSR	220	0.067	0.302
59	rabak	tandalti	112.26		2	2*240mm <sup>2</sup> ACSR	220	0.067	0.302

