



**Sudan University of Science and Technology**

**College of Engineering**

**Electrical Engineering**

**Study of Generation Protection at Garri 4  
Thermal Station**

**دراسة حماية التوليد لمحطة قري 4 الحرارية**

*A project Submitted in partial fulfillment for the requirement  
of the degree of B.Sc. (honor) in electrical engineering*

**Prepared by:**

1. Khalid Fathi Mohamaden Ibrahim
2. Abbas Kamal Mohamed Mustafa
3. Abdallah Ahmed Ali Alharith
4. Adnan Algaly Alameen Mustafa

**Supervised By:**

Ust.Gaffar Babiker Osman

**October 2018**

قال تعالى:

بسم الله الرحمن الرحيم

" يَرْفَعِ اللَّهُ الَّذِينَ آمَنُوا مِنْكُمْ وَالَّذِينَ أُوتُوا الْعِلْمَ دَرَجَاتٍ وَاللَّهُ بِمَا تَعْمَلُونَ خَبِيرٌ "

صدق الله العظيم

سوره المجادلة الآية رقم 11

## **DEDICATION**

All praise to Allah, today we fold the days' tiredness and the errand summing up between the cover of this humble work To the utmost knowledge lighthouse, to our greatest and most honored prophet Mohamed - May peace and grace from Allah be upon him To the Spring that never stops giving, to my mother who weaves my happiness with strings from her merciful heart to my mother. To whom he strives to bless comfort and welfare and never stints what he owns to push me in the success way who taught me to promote life stairs wisely and patiently, to my dearest father To those who taught us letters of gold and words of jewel of the utmost and sweetest sentences in the whole knowledge. Who reworded to us their knowledge simply and from their thoughts made a lighthouse guides us through the knowledge and success path, To our honoured teachers and professors.

## **ACKNOWLEDGMENT**

All praise due to Allah the Almighty for granting my strength and health to achieve this accomplishment.

We own our deepest gratitude to our advisor **A. Gaffer Babiker** First for accepting as a student, then for the support and help he has given our throughout the project.

Finally for what we appreciate the most, that he has given us the feeling that his “door is always open” when we had any kind of problem.

We wish to thank our committee members who were more than generous with their expertise and precious time.

We are grateful and thankful to engineers in **GARRI 4 POWER STATION** for their scientific support and their help.

We are also special thanks to Eng. Nihad Salah , Eng. Muhsin Mohamed

Finally we would like to thank the beginning teachers, mentor-Teachers and administrators in our school division that assisted us with this project. Their excitement and willingness to provide feedback made the Completion of this research an enjoyable experience.

## **ABSTRACT**

Generators are the most superior unit in power system, it consists of several parts such as stator, rotor and DC excitation system, each one of these parts must be protected from abnormal condition and faults. Several of protection functions and principles must be discussed and understand for strong generator protection schema. Generator protection schemes for GARRI 4 were carried out by collecting by collecting generator and protection data from the station, for analyzing these schemes and their calculations then simulating those using ETAP program and protection relays. Different scenarios of abnormal conditions and faults were created by using ETAP simulation to study and analyses. Same thing is said to protection relay, different current and voltage values were injected to simulate the abnormal conditions in order to display the relay response time. GARRI 4 generator protection system were studied and simulate.

## المستخلص

يعتبر المولد من الأجزاء الأساسية لنظام القدرة الكهربائية. و يحتوي من عدة أجزاء مثل : العضو الثابت و العضو الدوار و بالإضافة الى إثارة لتيار المستمر. أي جزء من هذه الأجزاء معرض لظروف غير طبيعية لذلك يجب حمايته من هذه الظروف والأعطال لما لها من تأثير سلبي على المولد في العادة تتم حماية المولدات من الأعطال و الظروف الغير طبيعية المسببة لها بواسطة أجزاء من داخل النظام أجزاء اخرى من خارجهم تحصيل المعلومات المطلوبة للحماية من محطة قري الحرارية و من ثم تم اجراء بعض الحسابات على مخططات الحماية و الحصول على نتائج تمت هذه الدراسة باستخدام برنامج (ETAP) حيث تم إدخال هذه النتائج في البرنامج و بدوره قام البرنامج بعملية تحليل المحاكاة في البرنامج تم انشاء عدة أحداث غير طبيعية لاختبار بيانات نظام الحماية فتم الحصول على نتائج مختلفة كاستجابة من نظام الحماية لهذه الظروف الغير طبيعية تمت دراسة و محاكاة بيانات حماية المولد في محطة قري الحرارية.

# TABLE OF CONTENTS

| Section | Contents             |      |
|---------|----------------------|------|
|         | الايه القرانيه       | i    |
|         | DEDICATION           | ii   |
|         | ACKNOWLEDGMENT       | iii  |
|         | ABSTRACT             | iv   |
|         | المستخلص             | v    |
|         | TABLE OF CONTENTS    | vi   |
|         | LIST OF FIGURE       | x    |
|         | LIST OF TABLE        | xii  |
|         | LIST OF ABBRVIATIONS | xiii |

## CHAPTER ONE

### INTRODUCTION

|     |                     |   |
|-----|---------------------|---|
| 1.1 | Overview            | 1 |
| 1.2 | Background          | 1 |
| 1.3 | Problem definition  | 1 |
| 1.4 | Aims and objectives | 2 |
| 1.5 | Methodology         | 2 |
| 1.6 | Thesis outline      | 2 |

## CHAPTER TWO

### ELECTRICAL PROTECTION

|     |              |   |
|-----|--------------|---|
| 2.1 | Introduction | 3 |
|-----|--------------|---|

|       |  |    |
|-------|--|----|
| 2.2   | Overview of electrical fault             | 3  |
| 2.2.1 | Electrical three phase system fault type | 4  |
| 2.3   | Protection component                     | 5  |
| 2.3.1 | Fuses                                    | 5  |
| 2.3.2 | Relays                                   | 5  |
| 2.3.3 | Instrument transformer(CT/VT)            | 8  |
| 2.4   | Zones of protection                      | 8  |
| 2.5   | Protection quality                       | 11 |
| 2.5.1 | Discrimination                           | 11 |
| 2.5.2 | Stability                                | 12 |
| 2.5.3 | Reliability                              | 12 |
| 2.5.4 | Speed of operation                       | 12 |
| 2.5.5 | Sensitivity                              | 13 |
| 2.6   | Generator protection types               | 13 |
| 2.6.1 | Overcurrent protection                   | 13 |
| 2.6.2 | Earth fault protection                   | 14 |
| 2.6.3 | differential protection                  | 15 |



## **CHAPTER THREE**

### **GARRI STATION OVERVIEW**

|       |   |    |
|-------|---|----|
| 3.1   | Introduction  | 17 |
| 3.2   | Garri -4 power plant generator  | 18 |
| 3.2.1 | Specifications of QF-60-2 type turbo generator for Garri -4 power plant | 19 |
| 3.3   | Generator protection scheme   | 19 |
| 3.3.1 | Over voltage  | 19 |
| 3.3.2 | Under voltage protection  | 20 |
| 3.3.3 | Reverse power protection  | 21 |
| 3.3.4 | Unbalance loading   | 23 |
| 3.3.5 | Under / over frequency and over fluxing protection                      | 23 |
| 3.3.6 | Loss of excitation protection   | 26 |
| 3.3.7 | Generator differential protection                                       | 27 |
| 3.3.8 | Stator earth fault protection   | 29 |
| 3.3.9 | Over current protection   | 29 |

## **CHAPTER FOUR**

### **SIMULATION AND RESULTS**

|       |                                    |    |
|-------|------------------------------------|----|
| 4.1   | Introduction                       | 31 |
| 4.2   | The single line diagram simulation | 32 |
| 4.3   | ETAP simulation result             | 33 |
| 4.3.1 | Over voltage protection            | 33 |
| 4.3.2 | Under voltage protection           | 34 |

|        |                               |    |
|--------|-------------------------------|----|
| 4.3.3  | Loss of field                 | 35 |
| 4.3.4  | Reverse power protection      | 35 |
| 4.3.5  | Unbalanced loading protection | 36 |
| 4.3.6  | Over frequency protection     | 37 |
| 4.3.7  | Under frequency protection    | 38 |
| 4.3.8  | Over fluxing protection       | 39 |
| 4.3.9  | Differential protection       | 41 |
| 4.3.10 | Stator earth fault protection | 43 |
| 4.3.11 | Over current protection       | 44 |
| 4.4    | Summary                       | 45 |

## **CHAPTER FIVE**

### **CONCLUSION**

|     |                |    |
|-----|----------------|----|
| 5.1 | Overview       | 47 |
| 5.2 | Recommendation | 47 |
|     | References     | 49 |

## List of figure

| Figure number | Title of figure   | page number |
|---------------|---|-------------|
| 2.1           | Type of faults on a three phase system.                   | 4           |
| 2.2           | Division of power system in to protection zone            | 9           |
| 2.3           | CT locations  | 10          |
| 2.4           | Overlapping zones of protection system                    | 10          |
| 2.5           | Typical Power / Time Relationship for Various Fault Types | 13          |
| 2.6           | Traditional over Current curve                            | 14          |
| 2.7           | Economical CT arrangement for O /C and E/ F               | 15          |
| 2.8           | Machine differential protection                           | 16          |
| 2.9           | Feeder differential protection                            | 16          |
| 3.1           | Generator-Transformer Unit                                | 18          |
| 3.2           | Abnormal operation condition                              | 19          |
| 3.3           | principle of circulating current differential protection  | 28          |
| 3.4           | Method of Discrimination by current                       | 30          |
| 4.1           | Single line Diagram of Simulation Circuit                 | 32          |
| 4.2           | Over Voltage action List                                  | 33          |
| 4.3           | Over Voltage (Voltage vs. Time) Graph at Bus1             | 33          |
| 4.4           | Under Voltage Action List                                 | 34          |
| 4.5           | Under Voltage (Voltage vs. Time) Graph at Bus1            | 34          |

|      |   |    |
|------|---|----|
| 4.6  | Loss of Field (Generator Reactive Power Vs. Time) Graph | 35 |
| 4.7  | Reverse Power action List                               | 35 |
| 4.8  | Reverse Power (Generator Active Power vs. Time) Graph   | 36 |
| 4.9  | Protection Operation of Un Balanced Loading Fault       | 36 |
| 4.10 | Negative Sequence Event Recorder                        | 37 |
| 4.11 | Over Frequency Action List                              | 37 |
| 4.12 | Over Voltage (Voltage vs. Time) Graph at Bus1           | 38 |
| 4.13 | Under Frequency Action list                             | 38 |
| 4.14 | Under Frequency (Frequency vs. Time) Graph at Bus1      | 39 |
| 4.15 | Over fluxing Action List                                | 39 |
| 4.16 | Over Fluxing (V/F vs. Time) Graph at Bus1               | 40 |
| 4.17 | Internal fault  | 41 |
| 4.18 | Differential Protection Event Recorder                  | 41 |
| 4.19 | External Fault  | 42 |
| 4.20 | Protection Operation of stator Earth Fault              | 43 |
| 4.21 | Stator Earth Fault Event Recorder                       | 43 |
| 4.22 | Protection operation of Over Current                    | 44 |
| 4.23 | Overcurrent Event Record                                | 45 |

## LIST OF TABLES

|     |                                 |    |
|-----|---------------------------------|----|
| 3.1 | Generator reverse power Problem | 22 |
|-----|---------------------------------|----|

## LIST OF ABBREVIATION

|       |  |
|-------|--|
| DC    | Direct Current                           |
| CT    | Current Transformer                      |
| CB    | Circuit Breaker                          |
| VT    | Voltage Transformer                      |
| SCADA | Supervisory control and data acquisition |
| DFT   | Discrete Fourier Transform               |
| DSP   | Digital Signal Processor                 |
| IDMT  | Inverse Definite Minimum Time            |
| SI    | Standard Inverse                         |
| VI    | Very Inverse                             |
| EI    | Extremely Inverse                        |
| O/C   | Over Current                             |
| E/F   | Earth Fault                              |
| STG   | Steam Turbine Generator                  |
| GTG   | Gas Turbine Generator                    |
| $X_d$ | Synchronous Reactance                    |
| $X'd$ | Transient Reactance                      |
| $X_e$ | Leakage Reactance                        |
| AVR   | Automatic Voltage Regulation             |
| ETAP  | Electrical Transient Analysis Program    |



# CHAPTER ONE

## INTRODUCTION

### **1.1 Overview:**

Sudan national networks consist of many generation stations that generate electrical power from different sources. GARRI is one of main generation stations that supply Sudan national network by about (500 MW).The reliability of this station is so important for supplying power to the network as well as the stability of the network. This reliability could be enhanced and grantee through proper protection systems.

### **1.2 Background:**

The history of electrical power technology throughout the world is one of steady and, in recent years, rapid progress, which has made it possible to design and construct economic and reliable power systems capable of satisfying the continuing growth in the demand for electrical energy. In this, power system protection and control play a significant part, and progress in design and development in these fields has necessarily had to keep pace with advances in the design of primary plant, such as generators, transformers, switchgears, overhead lines and underground cables, indeed, progress in the fields of protection and control is a vital prerequisite for the efficient operation and continuing development of power supply systems as whole.

### **1.3 Problem definition:**

The protection of generators is a hard task It involves the consideration of more possible abnormal operating conditions than the protection of any other system element. In unattended stations, automatic protection against all harmful abnormal conditions should be provided. But much difference of opinion exists as to what constitutes sufficient protection of generators in attended stations.



#### **1.4 Aims and objectives:**

The objectives of the project are to study protection of the power system elements at Garri4 power station specially the generators and analyze different Methods to protect the generators from potential faults.

#### **1.5 Methodology:**

In this project the investigation of elements protection will be done using data collection From Garri4 power station and simulation using ETAP program because ETAP is the most comprehensive solution for the design, simulation and analysis of Generation, transmission and distribution. Also protection relays will be used to give practical Results from the laboratory.

#### **1.6 Thesis outline:**

Chapter one provides essential background .chapter two will discuss protection system in general way, chapter three will illustrate the generator protection schemes used in Garri4 power station , chapter four with implementation of ETAP will provide the setting calculation used in protection scheme in the generator. Chapter five provides the recommendation and conclusion.

# **CHAPTRE TWO**

## **ELECTRICAL PROTECTION**

### **2.1 Introduction**

It is not economically feasible to design and manufacture electrical equipment that will never fail in service. Equipment will and do fail, and the only way to limit further damage, and to restrict danger to human life, is to provide fast, reliable electrical protection. The protection of a power system detects abnormal conditions, localizes faults, and promptly removes the faulty equipment from service.

Electrical protection is not an exact science, but is rather a philosophy based on a number of principles. There are countless unique circumstances where protection is needed, and the techniques that will be applied have to take the specific conditions into account. Economic principles, namely the cost of the equipment that is protected, the cost of the protection equipment itself, the secondary cost of an electrical fault (for example, lost revenue or production losses), as well as probability analyses, all play a role in determining the protection philosophy that will be followed.

### **2.2 Overview of electrical fault**

Electrical faults usually occur due to breakdown of the insulating media between live conductors or between a live conductor and earth. This breakdown may be caused by any one or more of several factors, for example, mechanical damage, overheating, voltage surges (caused by lightning or switching), ingress of a conducting medium, ionization of air, and deterioration of the insulating media due to an unfriendly environment or old age, or misuse of equipment.

Fault currents release an enormous amount of thermal energy, and if not cleared quickly, may cause fire hazards, extensive damage to equipment and risk to human life. Faults are classified into two major groups: symmetrical and unbalanced (asymmetrical). Symmetrical faults involve all three phases and cause extremely severe fault currents and system disturbances. Unbalanced faults include phase-to-phase, phase-to-ground, and phase-to-phase-to-ground faults. They are not as severe as symmetrical faults because not all three phases are involved. The least severe fault condition is a single phase-to-ground fault with the transformer neutral earthed through a resistor or reactor. However, if not cleared quickly, unbalanced faults will usually develop into symmetrical faults.

### 2.2.1 Electrical three phase System Fault Types:

- Single phase to ground fault
- Phase to Phase fault
- Double Phase to earth fault
- Three phase fault
- Three phase to ground fault

Figure 2.1 represent the types of electrical faults.

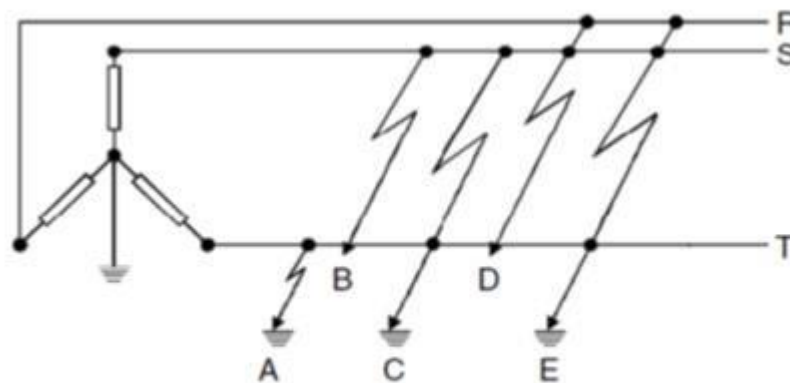

Figure 2.1 Type of faults on a three phase system.

## **2.3 Protection component**

A collection of protection devices (relays, fuses, etc.). Excluded are devices such as CT's, CB's, Contactors, etc.

### **2.3.1 Fuses**

Probably the oldest, simplest, cheapest, and most-often used type of protection device is the fuse. The operation of a fuse is very straightforward: The thermal energy of the excessive current causes the fuse-element to melt and the current path is interrupted. Technological developments have made fuses more predictable, faster, and safer (not to explode) Fuses are very inexpensive and they can operate totally independently, that is, they do not need a relay with instrument transformers to tell them when to blow. This makes them especially suitable in applications like remote ring main units, etc. (1)

### **2.3.2 Relays**

The most versatile and sophisticated type of protection available today, is undoubtedly the relay/circuit-breaker combination. The relay receives information regarding the network mainly from the instrument transformers (voltage and current transformers), detects an abnormal condition by comparing this information to pre-set values, and gives a tripping command to the circuit-breaker when such an abnormal condition has been detected. The relay may also be operated by an external tripping signal, either from other instruments, from a SCADA master, or by human intervention. Relays may be classified according to the technology used into:

#### **- ELECTROMECHANICAL RELAYS**

These relays were the earliest forms of relay used for the protection of power systems, and they date back nearly 100 years. They work on the principle of a

mechanical force causing operation of a relay contact in response to a stimulus. The mechanical force is generated through current flow in one or more windings on a magnetic core or cores, hence the term electromechanical relay. The principle advantage of such relays is that they provide galvanic isolation between the inputs and outputs in a simple, cheap and reliable form therefore for simple on/off switching functions where the output contacts have to carry substantial currents, they are still used. Electromechanical relays can be classified into several different types as follows:

- Attracted armature
- Moving coil
- Induction
- Thermal
- Motor operated
- Mechanical

## **- STATIC RELAYS**

Introduction of static relays began in the early 1960's. Their design is based on the use of analogue electronic devices instead of coils and magnets to create the relay characteristic. Early versions used discrete devices such as transistors and diodes in conjunction with resistors, capacitors, inductors, etc., but advances in electronics enabled the use of linear and digital integrated circuits in later versions for signal processing and implementation of logic functions. While basic circuits may be common to a number of relays, the packaging was still essentially restricted to a single protection function per case, while complex functions required several cases of hardware suitably interconnected. User programming was restricted to the basic functions of adjustment of relay characteristic curves. They therefore can be viewed in simple terms as an analogue electronic replacement for electromechanical relays, with some additional flexibility in settings and some saving in space requirements. In some cases, relay burden is reduced, making for reduced CT/VT output requirements.

## **- Digital Relays**

Digital protection relays introduced a step change in technology. Microprocessors and microcontrollers replaced analogue circuits used in static relays to implement relay functions. Early examples began to be introduced into service around 1980, and, with improvements in processing capacity, can still be regarded as current technology for many relay applications. However, such technology will be completely superseded within the next five years by numerical relays. Compared to static relays, digital relays introduce A/D conversion of all measured analogue quantities and use a microprocessor to implement the protection algorithm. The microprocessor may use some kind of counting technique, or use the Discrete Fourier Transform (DFT) to implement the algorithm. However, the typical microprocessors used have limited processing capacity and memory compared to that provided in numerical relays. The functionality tends therefore to be limited and restricted largely to the protection function itself. Additional functionality compared to that provided by an electromechanical or static relay is usually available, typically taking the form of a wider range of settings, and greater accuracy. A communications link to a remote computer may also be provided.

## **- Numerical Relays**

The distinction between digital and numerical relay rests on points of fine technical detail, and is rarely found in areas other than Protection. They can be viewed as natural developments of digital relays as a result of advances in technology. Typically, they use a specialized digital signal processor (DSP) as the computational hardware, together with the associated software tools. The input analogue signals are converted into a digital representation and processed according to the appropriate mathematical algorithm. Processing is carried out using a specialized microprocessor that is optimized for signal processing applications, known as a digital signal processor or DSP for short.

Digital processing of signals in real time requires a very high power microprocessor. In addition, the continuing reduction in the cost of microprocessors and related digital devices (memory, I/O, etc.) naturally leads to an approach where a single item of hardware is used to provide a range of functions („one-box solution“ approach). By using multiple microprocessors to provide the necessary computational performance, a large number of functions previously implemented in separate items of hardware can now be included within a single item.

### **2.3.3 Instrument transformers (CT\VT)**

Relays need information from the power network in order to detect an abnormal condition. This information is obtained via voltage and current transformers (collectively called instrument transformers), as the normal system voltages and currents are too high for the relays to handle directly, and the instrument transformers protect the relay from system

‘Spikes’ to a certain extent.[1]

### **2.4 Zones of protection**

To limit the extent of the power system that is disconnected when a fault occurs, protection is arranged in zones. The principle is shown in Figure 2.2

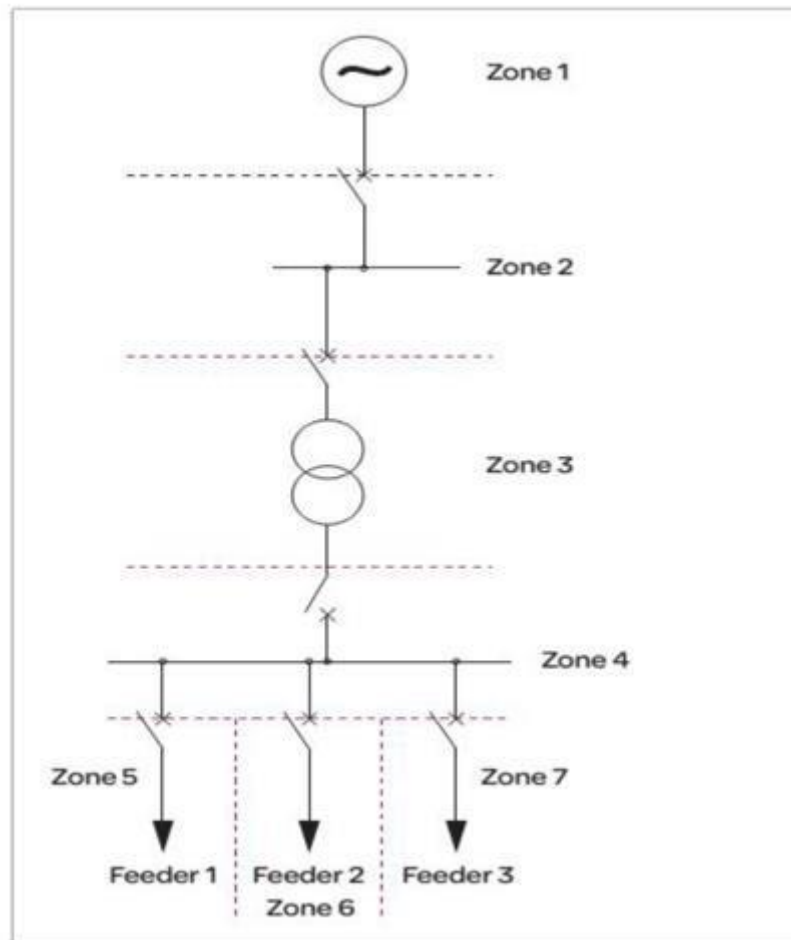

Figure 2.2 Division of Power System into Protection Zone

Ideally, the zones of protection should overlap, so that no part of the power system is left unprotected. The circuit breaker being included in both zones. For practical physical and economic reasons, this ideal is not always achieved, accommodation for current transformers being in some cases available only on one side of the circuit breakers. This leaves a section between the current transformers and the circuit breaker that is not completely protected against faults. In Figure 2.3 a fault at F would cause the bus bar protection to operate and open the circuit breaker but the fault may continue to be fed through the feeder. The feeder protection, if of the unit type, would not operate, since the fault is outside its zone. This problem is dealt with by inter-tripping or some form of zone extension, to ensure that the remote end of the feeder is tripped also.



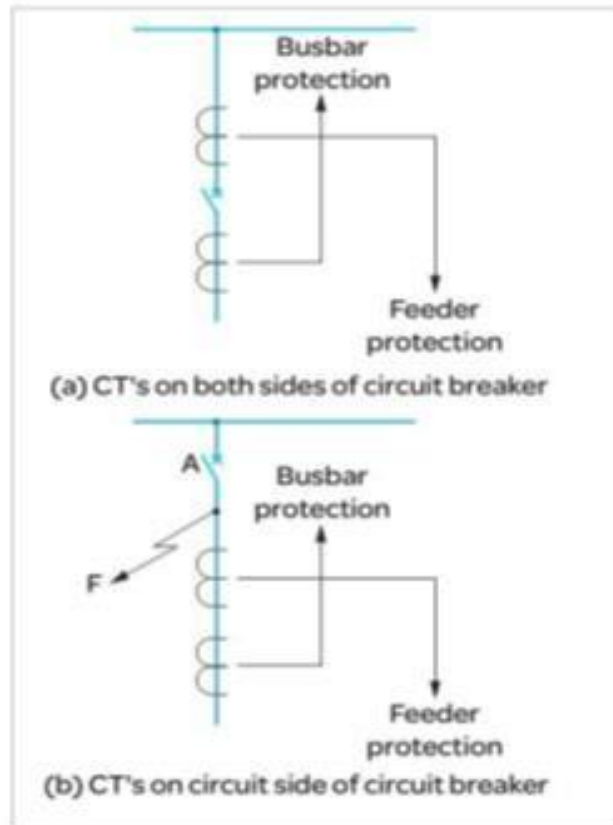

Figure2-3 CT locations

The point of connection of the protection with the power system usually defines the zone and corresponds to the location of the current transformers. Unit type protection will result in the boundary being a clearly defined closed loop. Figure 2.4 illustrates a typical arrangement of overlapping zones. [2]

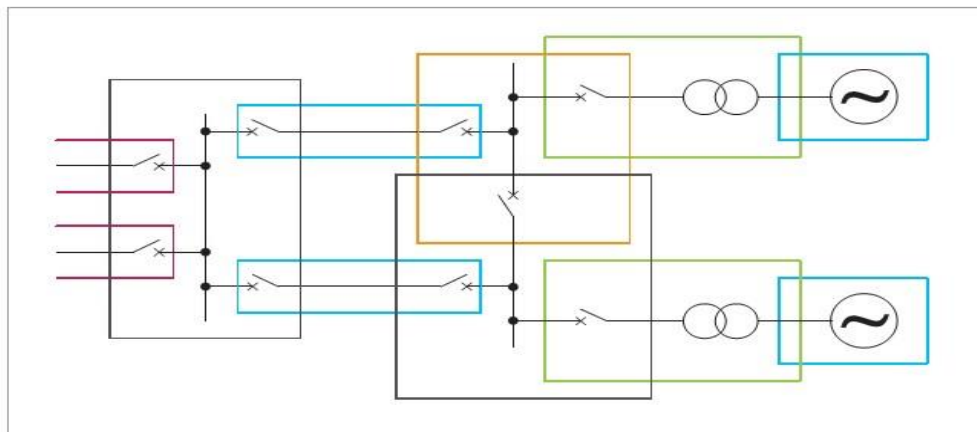

Figure 2.4 Overlapping Zones of Protection System

## **2.5 Protection quality**

Protection quality represents: discrimination, stability, reliability, speed of operation and sensitivity.

### **2.5.1 Discrimination**

Discrimination, or selectivity, is the ability of the protection to isolate only the faulted part of the system, minimizing the impact of the fault on the power network. Absolute discrimination is only obtained when the protection operates exclusively within a clearly defined zone. This type of protection is known as ‘unit protection’, as only one unit is exclusively protected for example, a transformer, or a specific feeder cable. The term ‘zone protection’ is also commonly used. Unit protection can only be achieved when the following essentials are satisfied: • Sensing or measuring devices must be installed at each

(Electrical) end of the protected equipment; and • There has to be a means of communication between the devices at each end, in order to compare electrical conditions and detect a fault when present.

#### **-The main advantages of unit protection are:**

- Only the faulted equipment or part of the network is disconnected, with minimum disruption to the power network.
- Unit protection operates very fast, limiting damages to equipment and danger to human life. Fast operation is possible because the presence or absence of a fault is a very clear-cut case.
  - Unit protection is very stable.
  - Unit protection is very reliable.
  - Unit protection is very sensitive.

**-The major disadvantages of unit protection are the following:**

- It is very expensive.

- It relies on communication between the relays installed at either end

### **2.5.2 Stability**

Stability, also called security, is the ability of the protection to remain inoperative for normal load conditions (including normal transients like motor starting). Most stability problems arise from incorrect application of relays and lack of maintenance.

### **2.5.3 Reliability**

Reliability, or dependability, is the ability of the protection to operate correctly in case of a fault. Reliability is probably the most important quality of a protection system

### **2.5.4 Speed of operation**

The longer the fault current is allowed to flow, the greater the damage to equipment and the higher the risk to personnel. Therefore, protection equipment has to operate as fast as possible, without compromising on stability. The best way to achieve this is by applying unit protection schemes. The phase shift between voltages at different bus bars on the system also increases, and therefore so does the probability that synchronism will be lost when the system is disturbed by a fault. The shorter the time a fault is allowed to remain in the system, the greater can be the loading of the system. Figure 2.5 shows typical relations between system loading and fault clearance times for various type of fault.

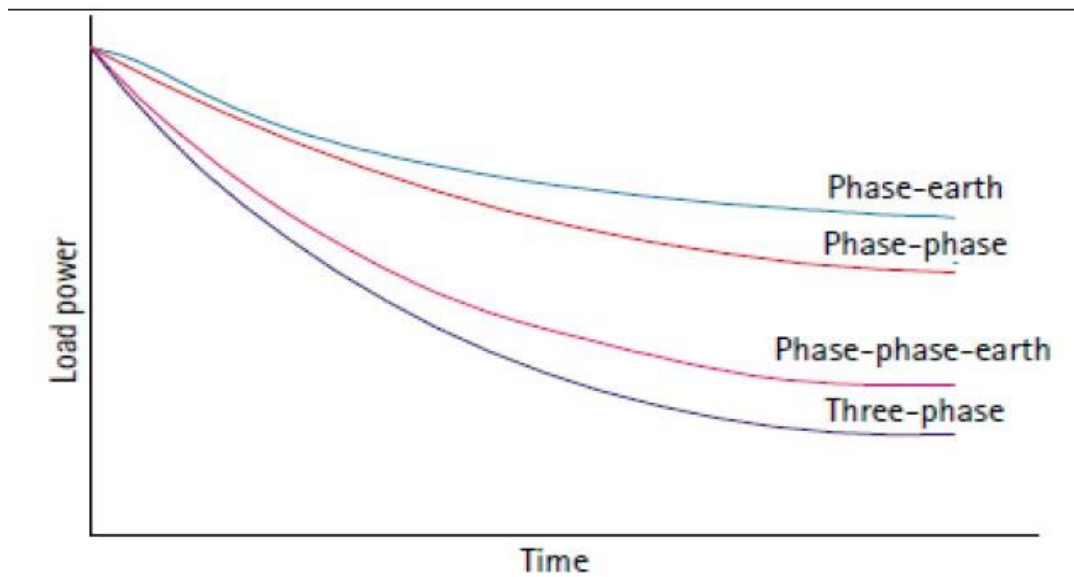

Figure 2.5 Typical Power / Time Relationship for Various Fault Types

### 2.5.5 Sensitivity

The term sensitivity refers to the magnitude of fault current at which protection operation occurs. A protection relay is said to be sensitive when the primary operating current is very low. Therefore, the term sensitivity is normally used in the context of electrical protection for expensive electronic equipment, or sensitive earth leakage equipment [2]

### 2.6 Generator protections Types:

- Over current protection
- Earth fault protection
- Differential protection

#### 2.6.1 Over Current Protection

The term “overcurrent” refers to abnormal current flow higher than the normal value of current flow in an electrical circuit. Uncorrected “overcurrent” can cause serious safety hazards and costly damage to electrical equipment and property. The overcurrent relay typically displays the inverse definite minimum time (IDMT) characteristic as displayed in Figure 2.6

Traditionally, normally inverse (NI), very inverse (VI), and extremely inverse (EI) have been applied, with each type of curve characteristic to a specific type of relay. Multitudes of curves, up to 15 in one relay, user selectable, are available with modern relays.

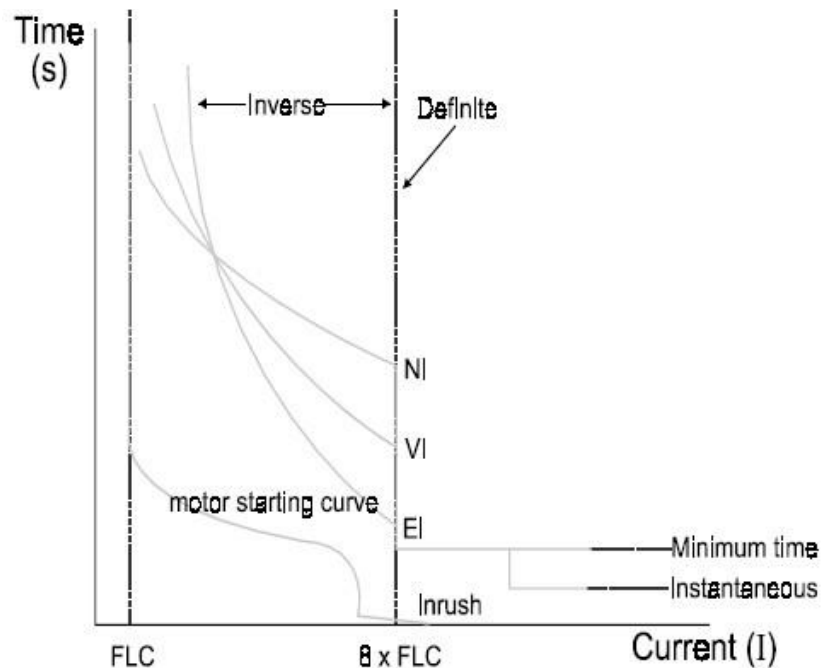

Figure 2.6 Traditional Over Current Curve

## 2.6.2 Earth fault protection

Phase-to-earth faults are covered by earth fault relays. The most common form of earth Fault protection operates on the principle that the vector sum of currents flowing in a balanced three-phase system equals zero. A very effective combination of overcurrent and earth fault protection has developed in the era of electromechanical relays, and the same principle is still used today in most protection schemes. This is illustrated in Figure 2.7

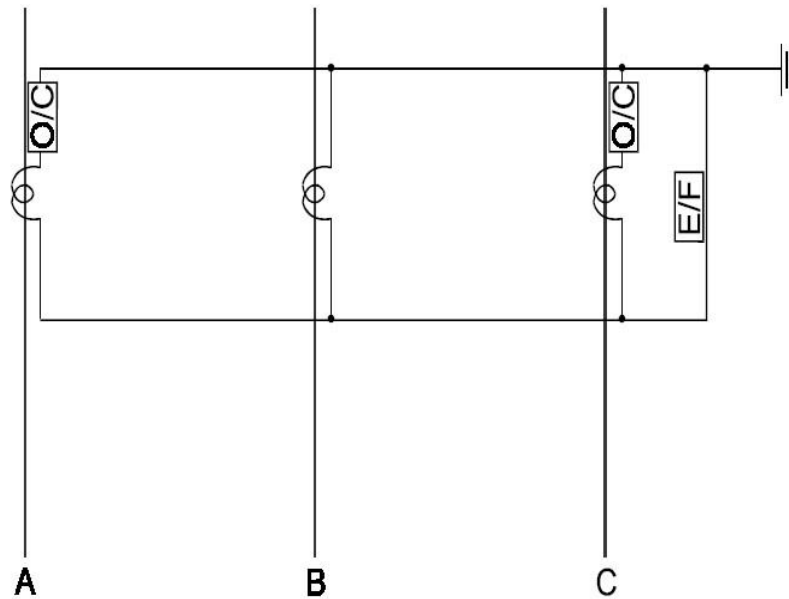

Figure 2.7 Economical CT Arrangement for O /C and E/ F

Only two phases need to be monitored by the overcurrent relay, the reason being that a fault on the third phase will be either to one of the other two phases, or to earth. A phase to-earth fault will cause an unbalance in the three phases, resulting in a current flowing in the earth fault element, tripping the earth fault relay. The same protection CTs are thus being used in this arrangement. [3]

### 2.6.3 Differential protection

Differential protection schemes vary according to the type of equipment to be protected, the most common being machine and feeder differential protection. The protection relays. Differ in their compensation methods for typical internal losses in the equipment to be protected, but operates on basically the same principle. The values of current going into and out of the equipment are measured and compared. The relay trips if the difference in Current exceeds a pre-set value, compensating for internal losses in the equipment and CT Inaccuracies. Figure 2.8 and figure 2.9 illustrate the use of a differential protection scheme.

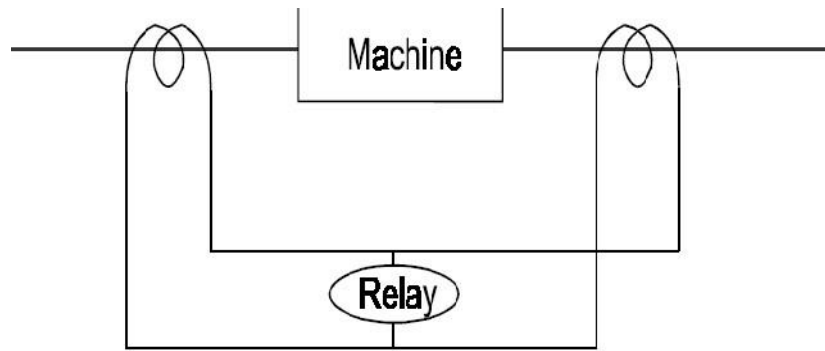

Figure 2.8 Machine Differential Protection

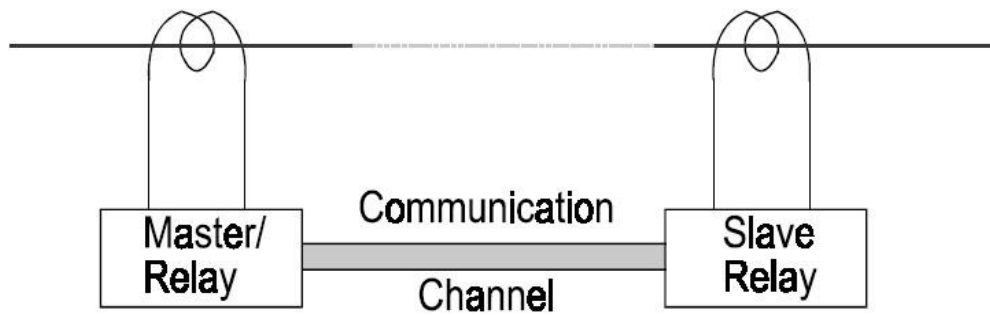

Figure 2.9 Feeder Differential Protection

With machine differential protection (motors or transformers), the sets of CTs are close to each other, and only relay needs to be used in most cases, with current flowing through the relay in case of a difference in current values. With feeder protection, the two sets CTs are far away from each other. Two relays are installed, one at both end of the equipment, one master and one slave. The slave relay measures the current at its end and sends it through to the master relay via the communication channel [1]

# **CHAPTER THREE**

## **GARRI STATION OVERVIEW**

### **3.1 Introduction**

It is imperative need to install some protective system to protect the expensive elements of modern power system such as generators, transformers, station bus-bar, and transmission lines etc. from different types of faults which are likely to occur sooner or later. In generating station as a continuous operation of generators is much more necessary so the fault part has to be cleared very quickly for uninterrupted power supply. Unlike other apparatus, opening a breaker to isolate the faulty generator is not sufficient to prevent further damage. The basic electrical quantities those are likely to change during abnormal fault conditions are current, voltage, phase angle and frequency. Protective elements utilizes one or more of these quantities to detect abnormal conditions in a power system for taking further essential steps to isolate the faulty equipment to keep the healthy part in normal working condition.

A modern generating unit is a complex system comprising the generator stator winding, associated transformer and unit transformer that shown in figure 10 (if present), the rotor with its field winding and excitation system, and the prime mover with its associated auxiliaries. Faults of many kinds can occur within this system for which diverse forms of electrical and mechanical protection are required. The amount of protection applied will be governed by economic considerations, taking into account the value of the machine, and the value of its output to the plant owner. Garri thermal power station consist of three planets; Garri one, Garri two and Garri four. Garri one and two are coupled together. Planet one consist of four Gas Turbines Generator (GTG) which capable rating each with an installed capacity of 10.5kV, 38 MW,



50Hz and two Steam Turbines Generator (STG) which capable rating each with an installed capacity of 10.5kV, 36MW, 50Hz. The study carried out planet four which consist of two Steam Turbines Generator (STG) which capable rating with an installed capacity of 11Kv, 60MW, 50Hz. Figure 3.1 represents generator-transformer unit at the plant.

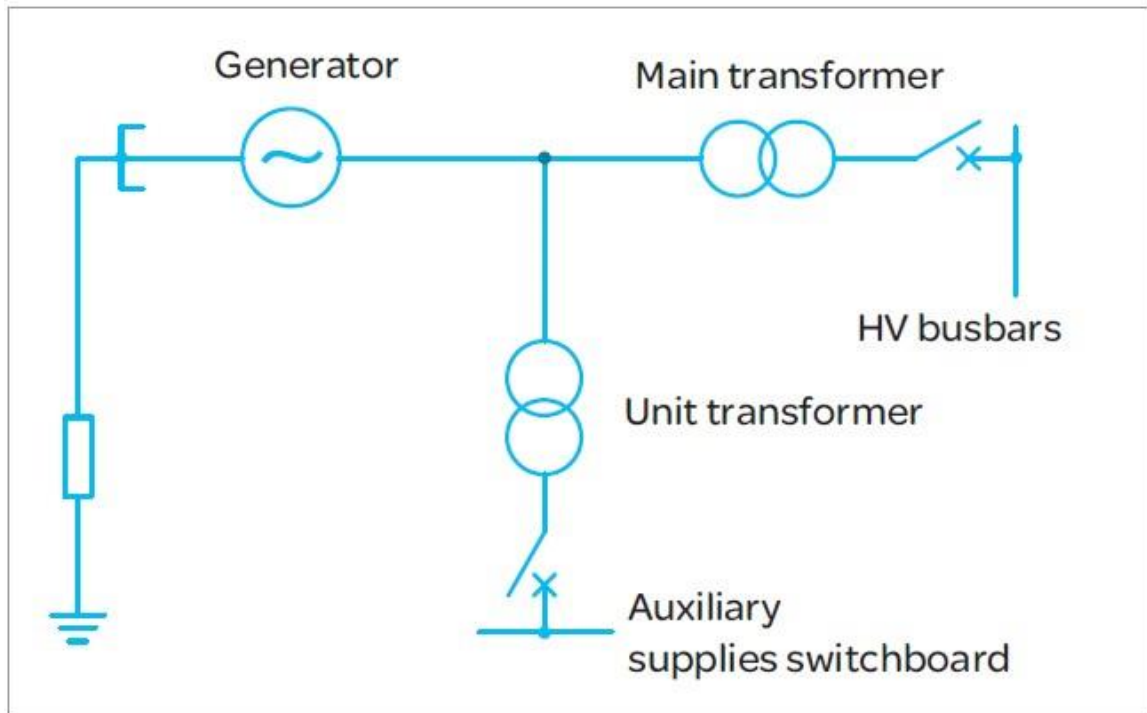

Figure 3.1 Generator-Transformer Unit

### 3.2 Garri-4 Power Plant Generator:

Garri-4 power plant adopts QF-60-2 type turbo-generator manufactured by Shanghai Turbo-Generator Co., Ltd. With the rated voltage of 11kV, the generator is driven by direct-coupled steam turbine, and is cooled by the enclosed circulating cooling air. The generator is of brushless excitation (by coaxial brushless exciter and permanent magnetism pilot exciter). The voltage of generator is adjusted by micro-computer WLZ-4DW automatic exciting regulator produced by the Hebei Industry University Electrical Factory in

China. From the view of steam turbine, the rotating direction of the QF-60-2, 60MW synchronous generator is in clockwise rotation.

### 3.2.1 Specifications of QF-60-2 Type Turbo-Generator for Garri-4 Power Plant

Generator rating : 60MW, 50HZ, 70.6MVA, 11KV, 370A , 0.85 PF ,  $X'_d=18\%$ ,  
 $X_d=166\%$  ,  $X_e=10.7\%$  , CT (5000/1 A) , VT(11/0.11 KV) Type of generator (QF-60-2)

### 3.3 Generator protection scheme

In the following sections, we consider some prominent abnormal operating conditions shown in figure 3.2 that need to be carefully considered while providing protection to the generator.

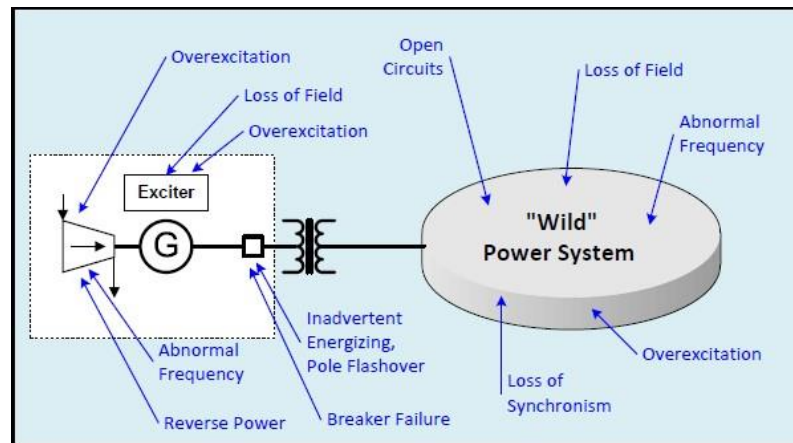

Figure 3.2 Abnormal operation condition

#### 3.3.1 Overvoltage

Over voltage event occurs when the power system loses the load or when the generator is feeding a very small load.

With health voltage regulator (AVR), over voltage should not happened, but it may be caused by the following contingencies:

- Defective operation of the automatic voltage regulator when the machine is in isolated operation.
- Operation under manual control with the voltage regulator out of service. A sudden variation of the load, in particular the reactive power

component, will give rise to a substantial change in voltage because of the large voltage regulation inherent in a typical alternator.

- Sudden loss of load (due to tripping of outgoing feeders, leaving the set isolated or feeding a very small load) may cause a sudden rise in terminal voltage due to the trapped field flux and/or over speed.

For these reasons, it is prudent to provide power frequency overvoltage protection, in the form of a time-delayed element, either IDMT or definite time. The time delay should be long enough to prevent operation during normal regulator action, and therefore should take account of the type of AVR fitted and its transient response.

**- Setting calculation:**

$$\begin{aligned} V>1 \text{ Voltage Set} &= 1.15 \times 110 = 126.5 \text{ V} && = \underline{126 \text{ V}} \\ V>1 \text{ TMS} &= (1.2 - 1) \times 2 = 0.4 && = \underline{0.4 \text{ (IDMT)}} \\ V>2 \text{ Voltage Set} &= 1.5 \times 110 = 165 \text{ V} \\ V>2 \text{ Time delay} &= 0.1 \text{ s} && = \underline{0.1 \text{ s}} \end{aligned}$$

### **3.3.2 Undervoltage Protection**

Undervoltage protection is rarely fitted to generators. It is sometimes used as an interlock element for another protection function or scheme, such as field failure protection or inadvertent energization protection, where the abnormality to be detected leads directly or indirectly to an undervoltage condition. However, it should be addressed by the deployment of 'system protection' schemes. The generation should not be tripped. The greatest case for undervoltage protection being required would be for a generator supplying an isolated power system or to meet Utility demands for connection of embedded generation. In the case of generators feeding an isolated system, undervoltage may occur for several reasons, typically overloading or failure of the AVR. In some cases, the performance of generator auxiliary plant fed

via a unit transformer from the generator terminals could be adversely affected by prolonged undervoltage. Where undervoltage protection is required, it should comprise an undervoltage element and an associated time delay.

**- Setting calculation:**

$$V<1 \text{ Voltage Set} = 0.8 \times 110 = 88 \quad =\underline{88}$$

$$V<1 \text{ TMS} = 3 \text{ s} \quad =\underline{3 \text{ s}} \text{ (for alarm)}$$

$$V<2 \text{ Voltage Set} = 0.7 \times 110 = 77 \text{ V} \quad =\underline{77 \text{ V}}$$

$$V<2 \text{ Time delay} = 2 \text{ s} \quad =\underline{2 \text{ s}}$$

### **3.3.3 Reverse Power Protection**

Protection against reverse power is provided for some generators to protect the prime mover parts which may not be designed to experience reverse torque or they may become damaged through continued rotation after the prime mover has suffered some form of failure. The reverse power protection should be provided with a definite time delay on operation to prevent spurious operation with transient power swings that may arise following synchronization or in the event of a power transmission system disturbance table 3.1 represent the generator reverse power problems.

Table 3.1: Generator reverse power problems

| Prime Mover   | Motoring Power (% of rated) | Possible Damage                     | Protection Setting    |
|---------------|-----------------------------|-------------------------------------|-----------------------|
| Diesel Engine | 5 - 25                      | Fire/explosion due to unburned fuel | 50% of motoring power |
|               |                             | Mechanical damage to gearbox/shafts |                       |
| Gas Turbine   | 10-15 (split shaft)         | gearbox damage                      |                       |
|               | > 50% (single shaft)        |                                     |                       |
| Hydro         | 0.2-2 (blades out of water) | blade and runner cavitation         |                       |
|               | > 2 (blades in water)       |                                     |                       |
| Steam Turbine | 0.5 - 6                     | turbine blade damage                |                       |
|               |                             | gearbox damage on geared sets       |                       |

**- Setting calculation**

Max motoring power for prime mover (IEEE std 242):

For steam turbine 3%

$$P_{1st} = \text{Generator rating} = \underline{60 \text{ MW}}$$

$$P_{2nd} = \text{Generator rating} / (\text{CT Ratio} \times \text{VT Ratio})$$

$$= (60 \times 10^6) / (5000 \times 100) = \underline{120 \text{ W}}$$

$$P_{>1} = 50\% \times 30\% \times P_{2nd}$$

$$= 0.5 \times 0.3 \times 120 = \underline{1.8 \text{ W}}$$

$$\text{Time Delay} = \underline{8 \text{ Sec}}$$

### 3.3.4 Unbalanced Loading

A three-phase balanced load produces a reaction field that, to a first approximation, is constant and rotates synchronously with the rotor field system. Any unbalanced condition can be resolved into positive, negative and zero sequence components. The positive sequence component is similar to the normal balanced load. The zero sequence components produce no main armature reaction.

#### - Effect of Negative Sequence Current

The resulting reaction field of the negative sequence rotates in the opposite direction to the D.Sc. field system. Hence, a flux is produced which cuts the rotor at twice the rotational velocity, thereby inducing double frequency currents in the field system and in the rotor body. The resulting eddy-currents are very large and cause severe heating of the rotor.

#### - Setting calculation:

$$FLC = 60 \times 1000 / (\sqrt{3} \times 11 \times 0.85) = \underline{3704.92 \text{ A}}$$

$$I_{2\text{therm}>1} \text{ Set} = 0.6 \times 0.1 \times 3704.92 \times (1/5000) = \underline{0.0444 \text{ A}}$$

$$I_{2\text{therm}>1} \text{ Delay} = 2\text{s} \therefore 2 \text{ s (for alarm)}$$

$$I_{2\text{therm}>2} \text{ Set} = 0.7 \times 0.1 \times 3704.92 \times (1/5000) = \underline{0.051 \text{ A}}$$

$$I_{2\text{therm}>2} \text{ K} = 15$$

$$I_{2\text{therm}>} t_{\text{max}} = 15 / 0.1^2 = \underline{1500\text{s}}$$

$$I_{2\text{therm}>} t_{\text{min}} = \underline{5\text{s}}$$

### 3.3.5 Under/Overfrequency and Overfluxing Protection

These conditions are grouped together because these problems often occur due to a departure from synchronous speed.

#### - Underfrequency

Underfrequency may occur as a result of overload of generators operating on an isolated system, or a serious fault on the power system that results in a

deficit of generation compared to load. This may occur if a grid system suffers a major fault on transmission lines linking two parts of the system, and the system then splits into two. Prime movers may have to be protected against excessively low frequency by tripping of the generators concerned. An under frequency condition, at nominal voltage, may result in some over fluxing of a generator and its associated electrical plant. The more critical considerations would be in relation to blade stresses being incurred with high-speed turbine generators; especially steam-driven sets. When not running at nominal frequency, abnormal blade resonance's can be set up that, if prolonged, could lead to turbine disc component fractures.

**- Overfrequency:**

Over frequency running of a generator arises when the mechanical power input to the alternator is in excess of the electrical load and mechanical losses. The most common occurrence of over frequency is after substantial loss of load. Over frequency protection may be required as a back-up protection function to cater for governor or throttle control failure following loss of load or during unsynchronized running. Moderate overfrequency operation of a generator is not as potentially threatening to the generator and other electrical plant as underfrequency running.

**- Setting calculation:**

Under/Over frequency protection should be set as per Off-frequency turbine limit but general typical data are considered in this report also these values can be changed as follow customer requirement.

**- Under frequency protection**

**- IEEE standards:**

F<1 Setting = 48.0 Hz

Time Delay = 10 s

F<2 Setting = 47.0 Hz

Time Delay = 3 s  
 F<3 Setting = 46.0 Hz  
 Time Delay = 2 s  
 F<4 Setting = 45.5 Hz  
 Time Delay = 0.1 s

**- Over frequency protection**

F<1 Setting = 52.0 Hz  
 Time Delay = 5 s  
 F<2 Setting = 53.0 Hz  
 Time Delay = 1s

**- Overfluxing**

Overfluxing is most likely to occur during machine start up or shut down whilst the generator is not connected to the system. Failures in the automatic control of the excitation system, or errors in the manual control of the machine field circuit, could allow excessive voltage to be generated. Overfluxing occurs when the ratio of voltage to frequency is too high. The iron saturates owing to the high flux density and results in stray flux occurring in components not designed to carry it. Overheating can then occur, resulting in damage. The problem affects both direct-and indirectly-connected generators. Either excessive voltage, or low frequency, or a combination of both can result in overfluxing, a voltage to frequency ratio in excess of 1.05p.u. , normally being indicative of this condition. Excessive flux can arise transiently, which is not a problem for the generator. For example, a generator can be subjected to a transiently high power frequency voltage, at nominal frequency, immediately after full load rejection.

**- Setting calculation:**

$$1\text{p.u V/Hz setting} = 11000 \times 110/11000 / 50\text{Hz} = 2.2 \text{ V/Hz}$$

$$\text{V/Hz Alm Set} = 2.2 \text{ V/Hz} \times 1.1 = 2.42 \text{ V/Hz}$$



Time Delay = 0.5s (for alarm)

V/Hz > 1 set = 2.2 x 1.1 = 2.42 V/Hz

Time Delay = 45 Sec

V/Hz > 2 Set = 2.2 X 1.15 = 2.53 V/Hz

Time Delay = 6 Sec

V/Hz > 3 Set = 2.2 X 1.2 = 2.64 V/Hz

Time Delay = 2 Sec

V/Hz > 4 Set = 2.2 X 1.25 = 2.75 V/Hz

Time Delay = 1 Sec

### **3.3.6 Loss of Excitation Protection**

A loss of field (LOF) occurs when excitation to the generator field winding fails. This may be a result of equipment failure, inadvertent opening of the field breaker, an open or short circuit in the excitation system, or slip ring flashover. Whatever the cause, this condition poses a threat to the generator and to the power system. The DC current input to the field winding excites the rotor magnetic circuit to establish rotor flux. This flux generates an internal voltage in synchronism with and opposed to the system voltage. When excitation is lost, the rotor current decays at a rate determined by the field circuit time constant. The internal generator voltage will decay at the same rate. If the generator is initially supplying Vars to the power system, the Var output will decrease through zero as the generator draws increasing reactive from the power system to replace excitation formerly provided by the field circuit. Var consumption can exceed the generator MVA rating. The reduction of internal voltage also weakens the magnetic coupling between the rotor and stator. At some point during the decay, the coupling will become too weak to transmit prime mover output power to the electrical system and the generator will lose synchronism.

This is similar to the loss of steady-state stability, to visualize the loss of synchronism following a LOF event; we refer to the power angle equation:

$$P_e = \frac{E_g E_s}{X_T} \sin \delta \quad 3.1$$

**- Setting calculation:**

$$Z_b = (\text{Base kV}^2 / \text{Base MVA}) \times (\text{CT Ratio} / \text{VT Ratio}) =$$

$$(11^2 / 70.6) \times (5000 / 100) = 85.6 \, \Omega$$

$$X_d = X'_d (\text{Pu}) \times Z_b = 0.18 \times 85.6 = 15.408 \, \Omega$$

$$X_d \, \Omega = 1.66 \times 85.6 = 142.096 \, \Omega$$

- Impedance element 1

$$F_{\text{fail}} - X_{a1} = 0.5 X_d = 0.5 \times 15.408 = 7.7 \, \Omega$$

$$F_{\text{fail}} - X_{b1} = X_d = 142.96$$

$$F_{\text{fail}} \text{ Time Delay} = 0.5 \text{ Sec}$$

- Impedance element

$$F_{\text{fail}} - X_{a2} = 0.5 X'_d = 0.5 \times 15.408 = 7.7 \, \Omega$$

$$F_{\text{fail}} - X_{b2} = \text{KV}^2 / \text{MVA} = 85.6 \, \Omega$$

$$F_{\text{fail}} \text{ Time Delay} = 0 \text{ Se}$$

### 3.3.7 Generator Differential Protection

The circulating current differential protection operates on the principle that any current entering and leaving a zone of protection will be equal. Any difference between these currents is indicative of a fault being present in the zone. Figure 3.3 represent the principle of circulating current differential protection.

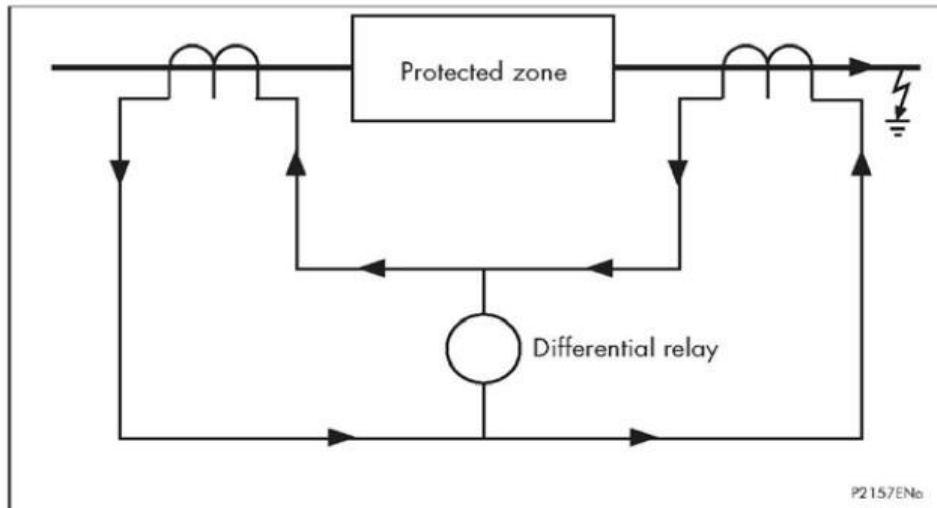

Figure 3.3 Principle of circulating current differential protection

It can be seen that current flowing through the zone of protection will cause current to circulate around the secondary wiring. If the CTs are of the same ratio and have identical magnetizing characteristics they will produce identical secondary currents and hence zero current will flow through the relay. If a fault exists within the zone of protection there will be a difference between the outputs from each CT; this difference flowing through the relay causing it to operate. The calculation is performed on a per phase basis. The differential current is the vector sum of the phase currents measured at either end of the generator. The mean bias current ( $I_{bias}$ ) is the scalar mean of the magnitude of these currents.

**- Setting calculation:**

$$FLC = 60 \times 1000 / (\sqrt{3} \times 11 \times 0.85) = 3704.92A$$

$$Gen\ Diff\ Is1 = 0.1 \times 3704.92 \times (1/5000) = 0.07\ A \quad = 0.1\ A$$

$$Gen\ Diff\ Is2 = 1.2 \times 3704.92 \times (1/5000) = 0.89\ A \quad = 0.9\ A$$

$$Gen\ Diff\ k1 = 10\% \text{ (IEEE Std. 242 recommendation)} = 10\%$$

$$Gen\ Diff\ k1 = 150\% \text{ (Manufacture recommendation)} = 150\%$$

### 3.3.8 Stator earth fault protection

Earth fault protection must be applied where impedance earthing is employed that limits the earth fault current to less than the pick-up threshold of the overcurrent and/or differential protection for a fault located down to the bottom 5% of the stator winding from the star-point. The type of protection required will depend on the method of earthing and connection of the generator to the power system.

#### - Setting calculation:

The maximum generator neutral transformer secondary voltage;

$$V_{max} = (11000/\sqrt{3}) \times (0.11/6.3) \text{ V} = 110.887 \text{ V}$$

For 95% protection of the windings, the relay should be set as follows;

$$I_{N1>1} \text{ Current} = 0.05 \times (110.887/0.191) \times (1/1000) \text{ A} = 0.029 \text{ A} = 0.03 \text{ A}$$

$$\text{Time Delay} = 0.5 \text{ s} = 0.5 \text{ s}$$

[Calculation for 100% stator earth fault protection, 3rd harmonic method]  
100% St. EF

$$V_{N3H} = 1\% \text{ of input voltage}$$

$$= 0.01 \times 110.887 \text{ V} = 1.1088 \text{ V} = 1.1 \text{ V}$$

Time Delay = 1 s = 1 s Existing value 1s should be considered.

### 3.3.9 over current protection

The system requires discriminative protection designed to disconnect the minimum amount of circuit and load that will isolate the fault. Correct over current relay application requires knowledge of the fault current that can flow in each part of the network. Since large-scale tests are normally impracticable, system analysis must be used, the relay settings are first determined to give the shortest operating times at maximum fault levels and then checked to see if operation will also be satisfactory at the minimum fault current expected

thus, the relay farthest from the source has current settings equal to or less than the relays behind it

### - Discrimination by current

Discrimination by current relies on the fact that the fault current varies with the position of the fault because of the difference in impedance values between the source and the fault. Hence, typically, the relays controlling the various circuit breakers are set to operate at suitably tapered values of current such that only the relay nearest to the fault trips its breaker. The figure 3.4 illustrates the method

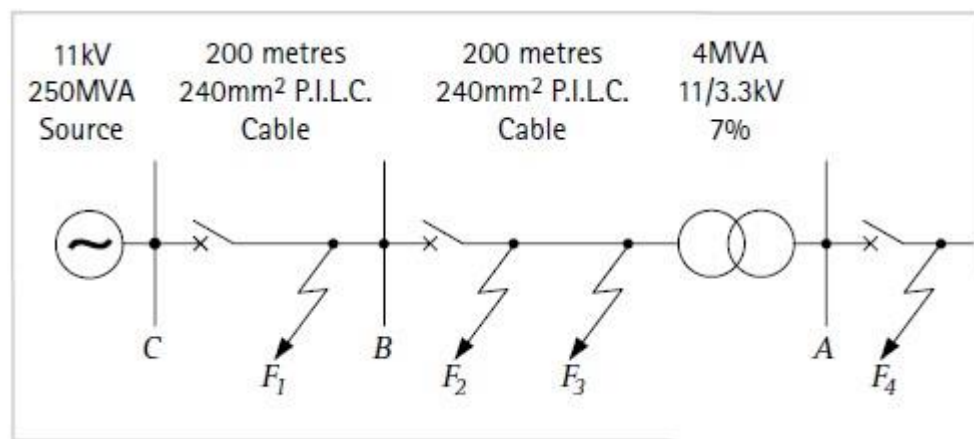

Figure 3.4 Method of Discrimination by Current

The figure illustrates that the relay at zone A trip first, then the relays at zone B, and finally the relay at zone C. it is not practical to distinguish between a fault at F1 and a fault at F2, since the distance between these points may be only a few meters, corresponding to a change in fault current of approximately 0.1%

# **CHAPTER FOUR**

## **SIMULATION AND RESULTS**

### **4.1 Introduction**

Protection system was simulated by using power system software program called ETAP (Electrical Transient and Analysis Program).

ETAP power system software is the most comprehensive analysis platform for the design, simulation, operation and automation of generation, distribution and industrial power system.

ETAP offers a suite of fully integrated electrical engineering software solutions including arc flash, load flow, short circuit, transient stability, relay coordination, optimal power flow and more. Its modular functionality can be customized to fit the needs of any company, from small to large power system.

ETAP is developed under an established quality assurance program and is used worldwide as a high Impact software. ETAP is completely localized in seven languages with translated output reports in eight languages. As a fully integrated enterprise solution, ETAP Extends to a Real-Time Power Management System.

To monitor, control, automate, simulate, and optimize the operation of power systems.

## 4.2 The Single Line Diagram Simulation

The following diagram (figure 4.1) illustrates a single line diagram of the circuit used to simulate the generator protection system

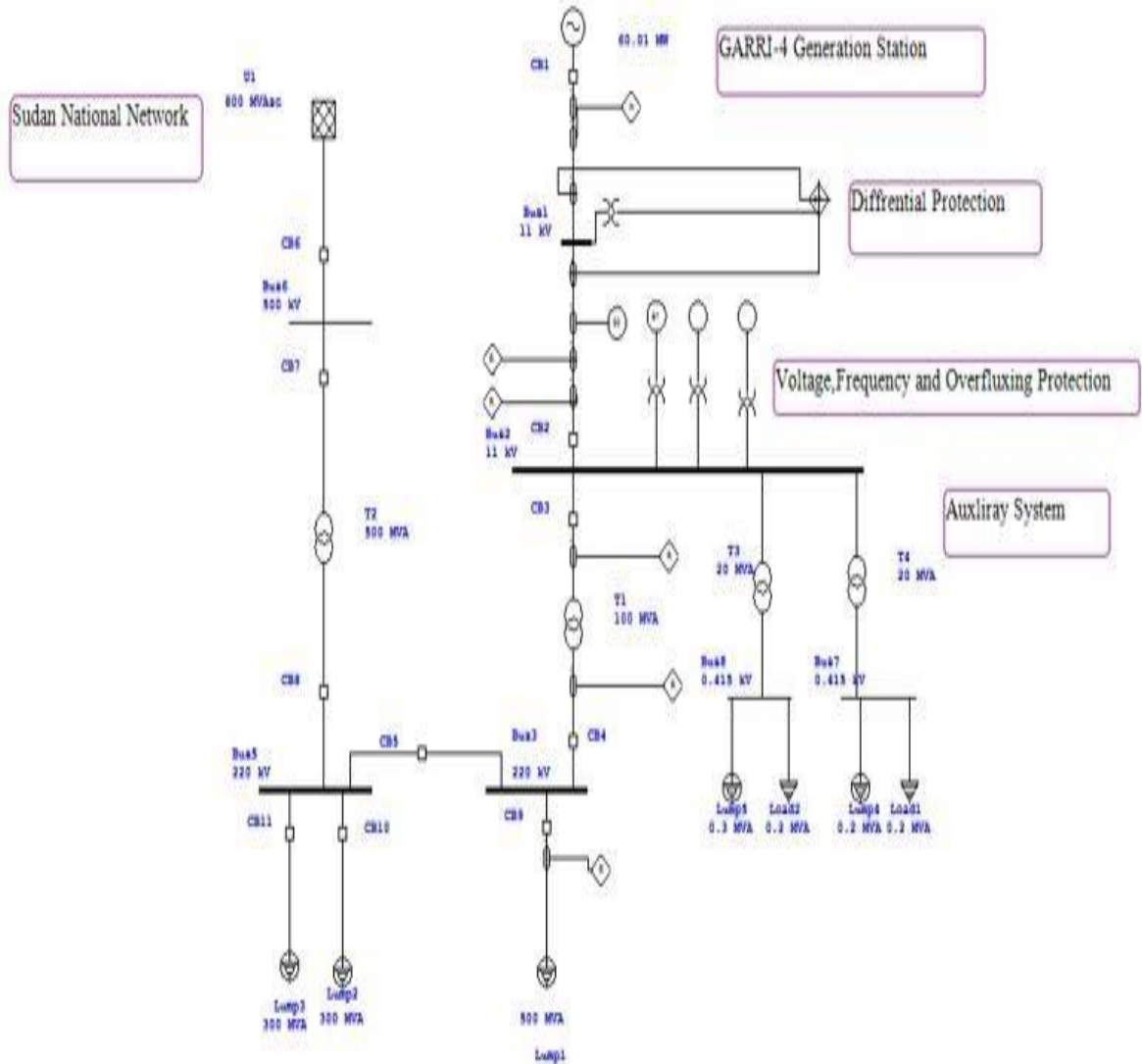

Figure 4.1 Single line Diagram of Simulation Circuit

### 4.3 ETAP simulation result

Result are represent as shown:

#### 4.3.1 OverVoltage Protection

Figure 4.2 illustrates the over voltage action list.

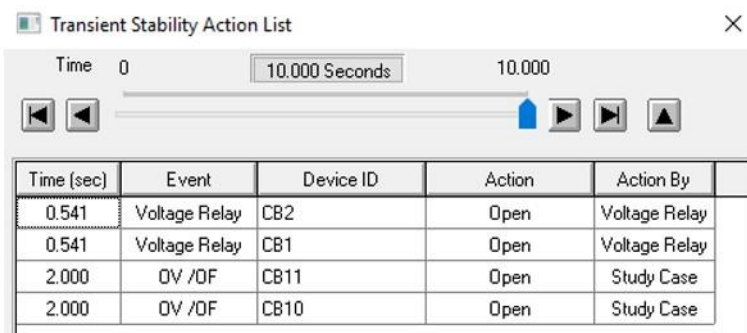

The screenshot shows a window titled "Transient Stability Action List" with a time slider set to 10.000 seconds. Below the slider is a table with the following data:

| Time [sec] | Event         | Device ID | Action | Action By     |
|------------|---------------|-----------|--------|---------------|
| 0.541      | Voltage Relay | CB2       | Open   | Voltage Relay |
| 0.541      | Voltage Relay | CB1       | Open   | Voltage Relay |
| 2.000      | OV /OF        | CB11      | Open   | Study Case    |
| 2.000      | OV /OF        | CB10      | Open   | Study Case    |

Figure 4.2 Over Voltage action List

- The over voltage scenario was created by opening CB 10 and CB11 to disconnect large loads.
- Bus 1 (generator terminal) voltage reached the relay setting, hence, the voltage relay trips

Figure 4.3 represents over voltage (voltage vs. time) graph at bus 1.

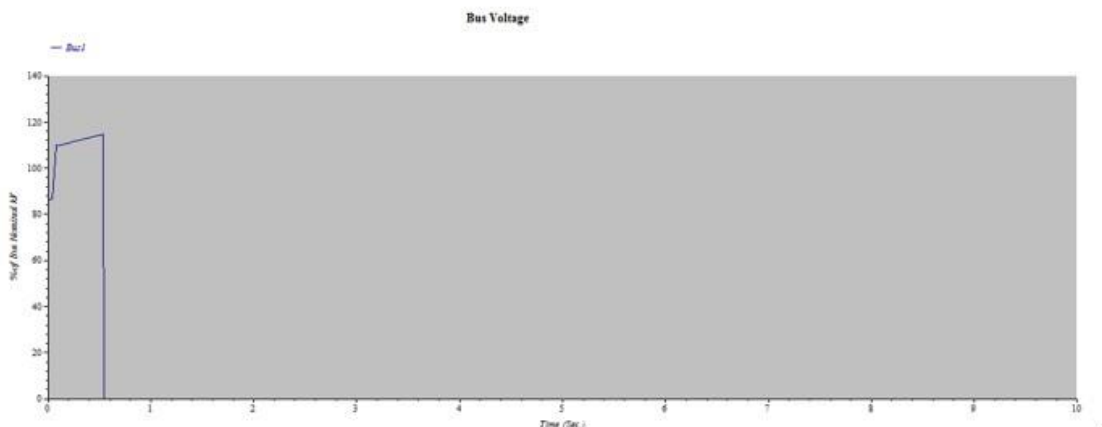
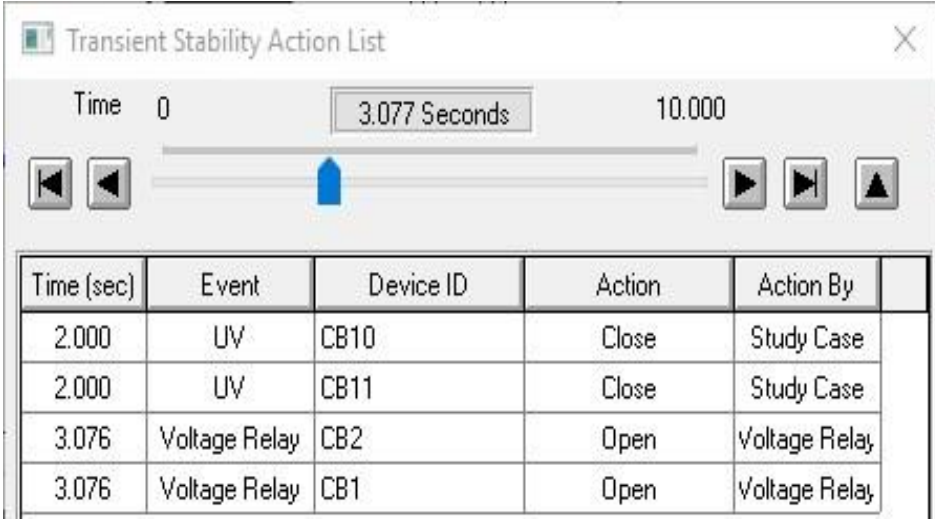

Figure 4.3 Over Voltage (Voltage vs. Time) Graph at Bus1



### 4.3.2 Under Voltage protection

Figure 4.4 represent under voltage action list.



| Time (sec) | Event         | Device ID | Action | Action By     |
|------------|---------------|-----------|--------|---------------|
| 2.000      | UV            | CB10      | Close  | Study Case    |
| 2.000      | UV            | CB11      | Close  | Study Case    |
| 3.076      | Voltage Relay | CB2       | Open   | Voltage Relay |
| 3.076      | Voltage Relay | CB1       | Open   | Voltage Relay |

Figure 4.4 Under Voltage Action List

- The under voltage scenario was created by closing CB 10 and CB11 to insert a large loads.
- CB 1 and CB 2 trip after detecting the under voltage fault in Bus 1 (Generator terminal).

Figure 4.5 represent under voltage (voltage vs. time) graph at bus1.

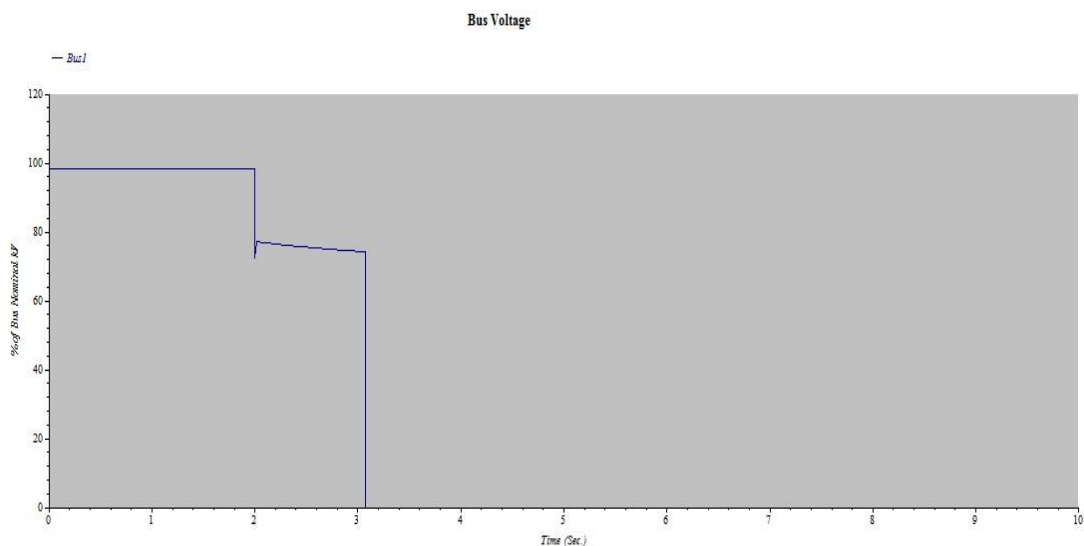

Figure 4.5 Under Voltage (Voltage vs. Time) Graph at Bus1

### 4.3.3 Loss of Field

Figure 4.6 represent loss of field (generator reactive power vs. time) graph.

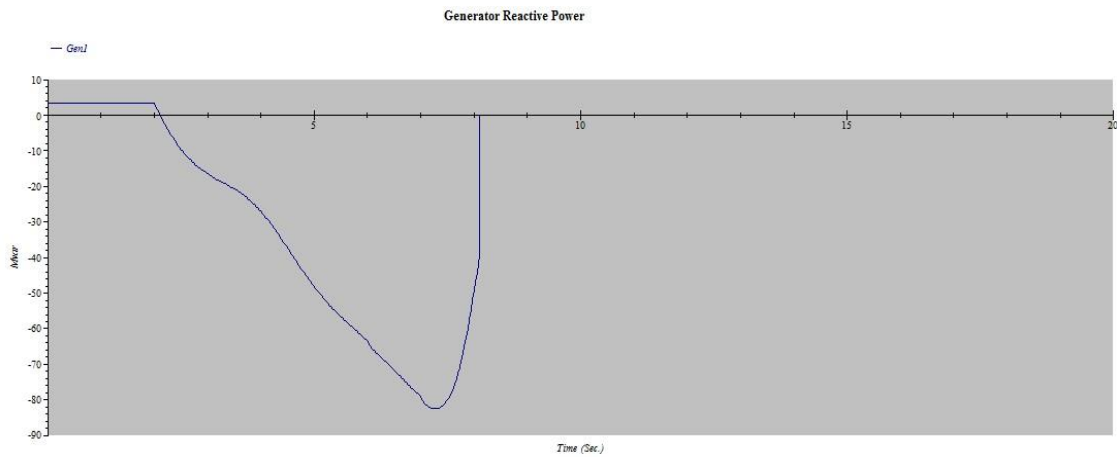

Figure 4.6 Loss of Field (Generator Reactive Power Vs. Time) Graph

- It is created by choosing loss of excitation option from transient stability analysis.
- The reactive power draw from the system before the condition is detected by the relay and then trip.

### 4.3.4 Reverse Power Protection

Figure 4.7 represent the reverse power action list.

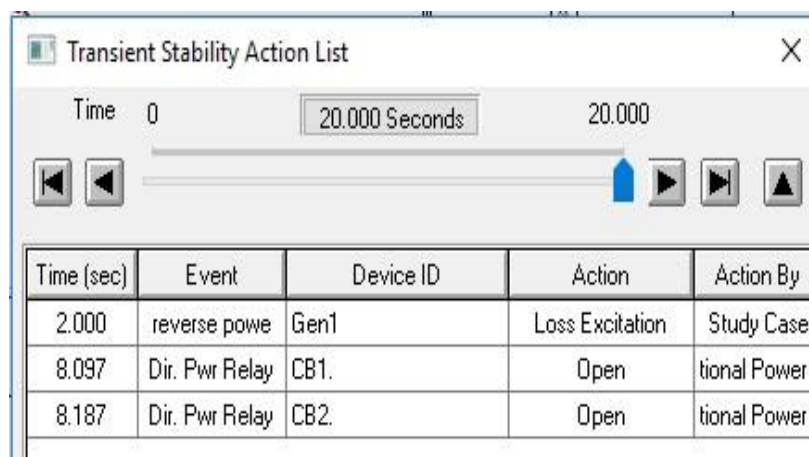

Figure 4.7 Reverse Power action List

- The relay waits 8 seconds then trips.

Figure 4.8 represent the reverse power (generator active power vs. time) graph.

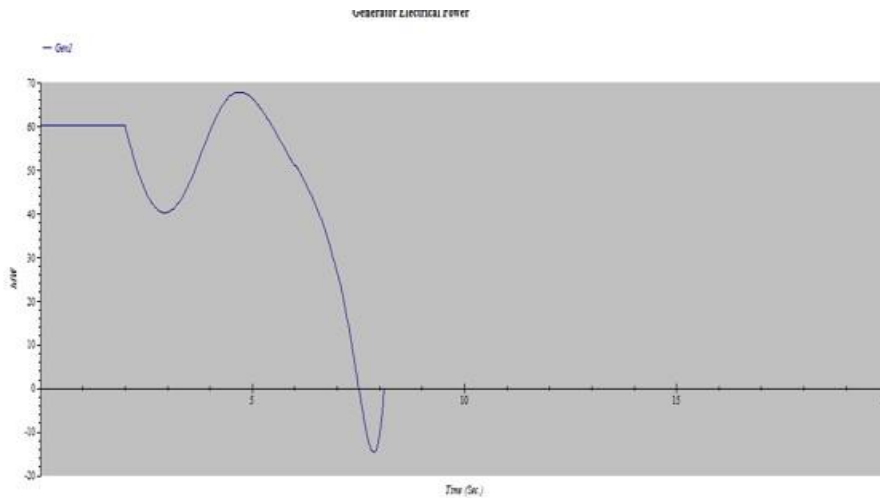

Figure 4.8 Reverse Power (Generator Active Power vs. Time) Graph

- It is created by choosing loss of excitation option from transient stability analysis.
- The direction of the real power reverses before the relay detects the condition.

### 4.3.5 Unbalanced Loading Protection

Figure 4.9 represents Protection Operation of Unbalanced Loading Fault

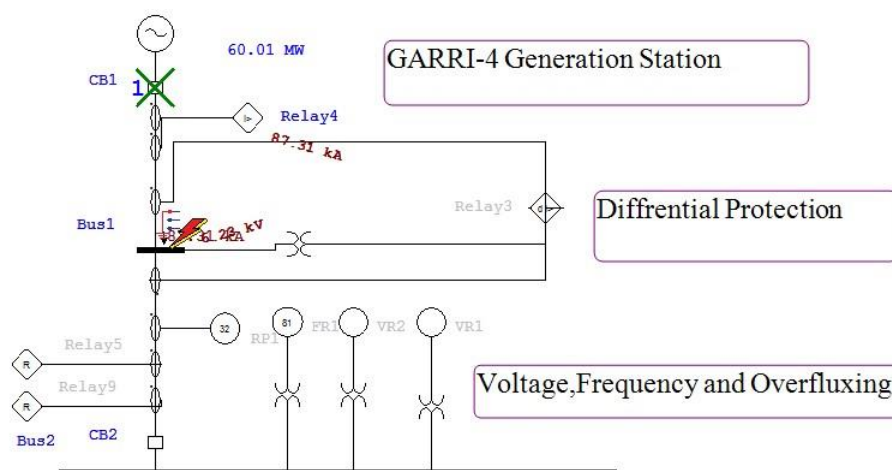

Figure 4.9 Protection Operation of Unbalanced Loading Fault

- In the normal condition positive sequences are applied to the system.
- Negative sequence event created by choosing line to ground fault at Bus1 since the fault occurs. Negative sequence current will appear in the system .Figure 4.10 Negative sequence event recorder.

| Time (ms) | ID     | If (kA) | T1 (ms) | T2 (ms) | Condition                                      |
|-----------|--------|---------|---------|---------|--|
| 2000      | Relay4 | 10.836  | 2000    |         | Negative Sequence - OC1 - 51                   |
| 2010      | CB1    |         | 10.0    |         | Tripped by Relay4 Negative Sequence - OC1 - 51 |
| 2010      | CB2    |         | 10.0    |         | Tripped by Relay4 Negative Sequence - OC1 - 51 |

Figure 4.10 Negative Sequence Event Recorder

- The Multifunction relay used as negative sequence current protection relay to detects the faulty condition.
- CB1 and CB2 trips after 0.01 second from the detected fault.

### 4.3.6 Over frequency protection

Figure 4.11 represents the over frequency action list.

| Time (sec) | Event        | Device ID | Action | Action By    |
|------------|--------------|-----------|--------|--------------|
| 2.000      | over frequen | CB11.     | Open   | Study Case   |
| 2.000      | over frequen | CB10.     | Open   | Study Case   |
| 2.000      | over frequen | CB9.      | Open   | Study Case   |
| 13.201     | Freq. Relay  | CB1.      | Open   | equency Rel. |
| 13.291     | Freq. Relay  | CB3.      | Open   | equency Rel. |
| 13.291     | Freq. Relay  | CB2.      | Open   | equency Rel. |

Figure 4.11 Over Frequency Action List

- The over frequency scenario was created by opening CB 9, CB 10 and CB11 to disconnect large loads.

- Bus 1 (generator terminal) frequency reached the relay setting, hence, the frequency relay trips

Figure 4.12 represents the over voltage (voltage vs. time) graph at bus1.

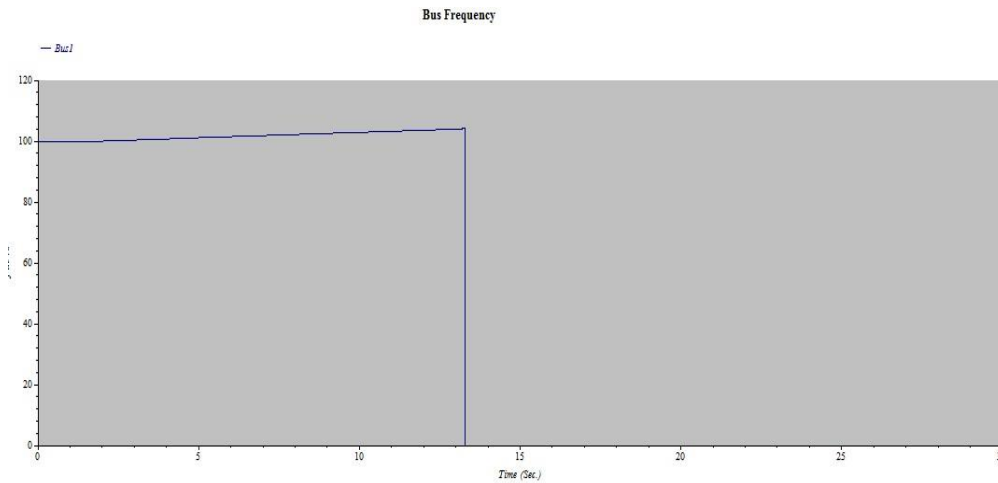

Figure 4.12 Over Voltage (Voltage vs. Time) Graph at Bus 1

### 4.3.7 Underfrequency Protection

Figure 4.13 represents the Under Frequency Action list.

| Time (sec) | Event        | Device ID | Action | Action By    |
|------------|--------------|-----------|--------|--------------|
| 2.000      | underfrequen | CB10.     | Close  | Study Case   |
| 2.000      | underfrequen | CB9.      | Close  | Study Case   |
| 2.000      | underfrequen | CB11.     | Open   | Study Case   |
| 17.686     | Freq. Relay  | CB1.      | Open   | requency Rel |
| 17.776     | Freq. Relay  | CB3.      | Open   | requency Rel |
| 17.776     | Freq. Relay  | CB2.      | Open   | requency Rel |

Figure 4.13 Under Frequency Action list

-The under frequency scenario was created by closing CB 9, CB 10 and CB11 to insert a large loads.

Figure 4.14 represent under frequency (frequency vs. time) graph at bus1.

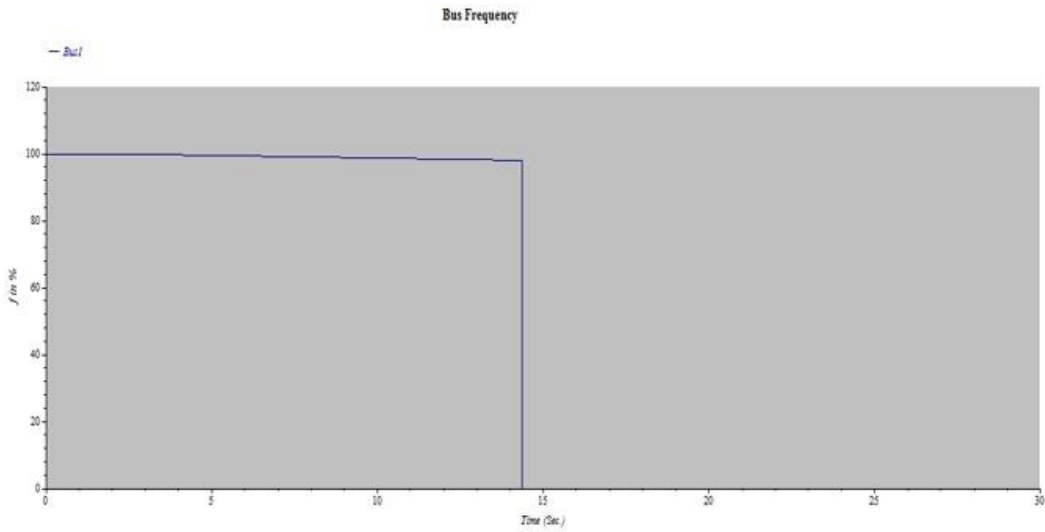

Figure 4.14 Under Frequency (Frequency vs. Time) Graph at Bus1

- Bus 1 (generator terminal) frequency reached the relay setting frequency after 15 seconds from event occurring.

### 4.3.8 Overfluxing Protection

Figure 4.15 represents the over fluxing action list.

| Time (sec) | Event         | Device ID | Action | Action By     |
|------------|---------------|-----------|--------|---------------|
| 2.000      | OV /OF        | CB11      | Open   | Study Case    |
| 2.000      | OV /OF        | CB10      | Open   | Study Case    |
| 6.838      | Voltage Relay | CB2       | Open   | Voltage Relay |
| 6.838      | Voltage Relay | CB1       | Open   | Voltage Relay |

Figure 4.15 Over fluxing Action List

- The over fluxing scenario was created by disconnecting large loads from the system by opening CB10 and CB11.

Figure 4.16 represents over fluxing (v/f vs. time) graph bus1.

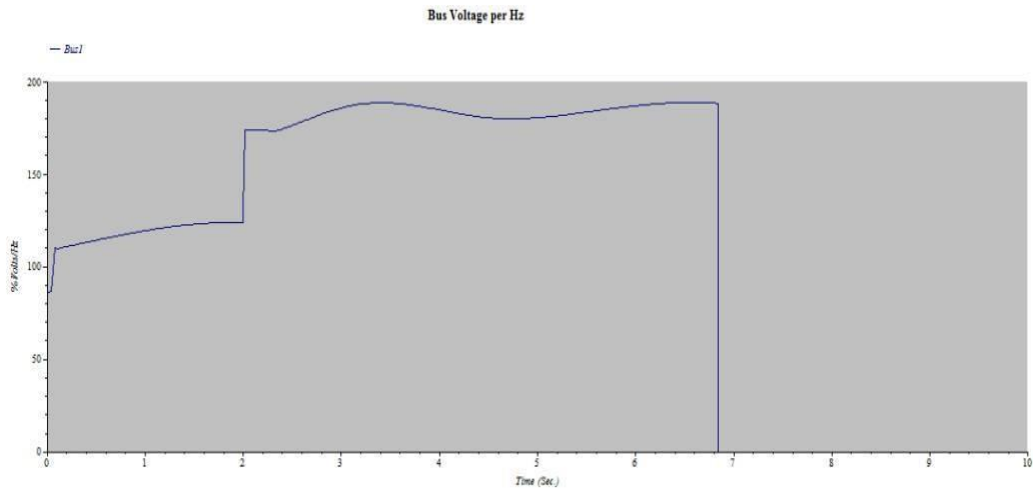

Figure 4.16 Over Fluxing (V/F vs. Time) Graph at Bus1

- CB1 and CB2 trips after Bus1 voltage over frequency ratio reached the relaying setting.

### 4.3.9 Differential Protection

Figure 4.17 represents the internal fault.

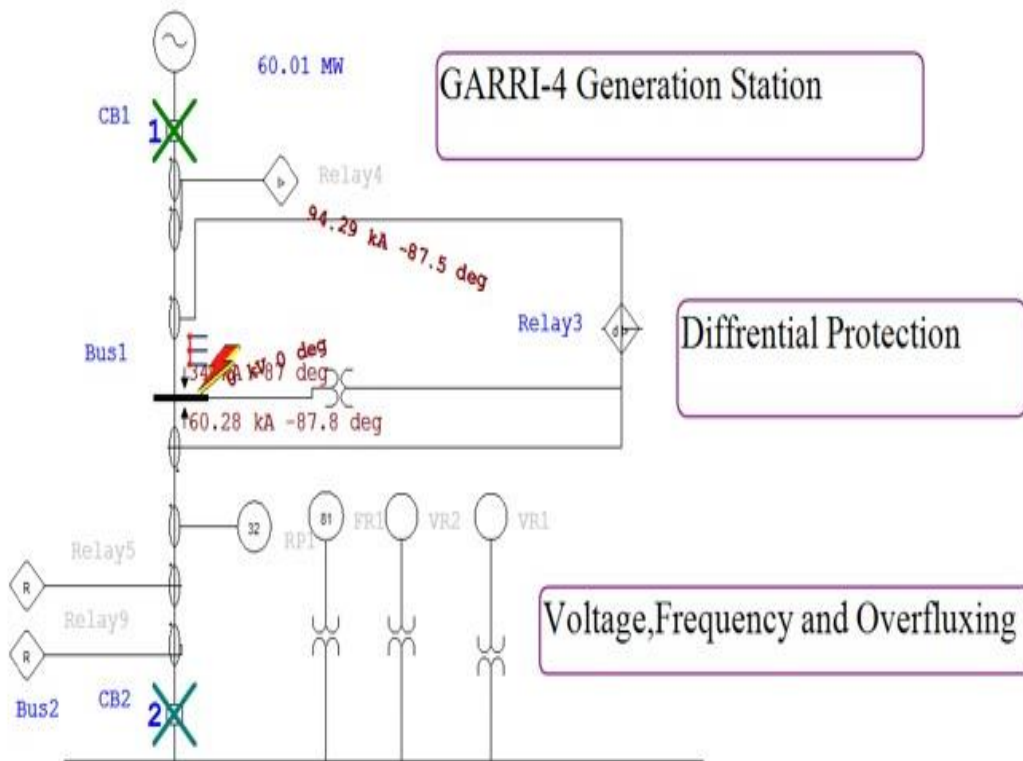

Figure 4.17 Internal fault

- Unit protection for Bus1 was applied by using two current transformers CT 20 and CT 21 with opposite polarity.
- In this case 3 phase fault occurred in the protected zone (Bus 1).

Figure 4.18 represents differential protection event recorder.

| Time (ms) | ID     | If (kA) | T1 (ms) | T2 (ms) | Condition                    |
|-----------|--------|---------|---------|---------|------------------------------|
| 20.0      | Relay3 |         | 20.0    |         | Phase - 87                   |
| 30.0      | CB1    |         | 10.0    |         | Tripped by Relay3 Phase - 87 |
| 30.0      | CB2    |         | 10.0    |         | Tripped by Relay3 Phase - 87 |

Figure 4.18 Differential Protection Event Recorder



- CB1 and CB2 trips after 0.01 second from detecting the fault by differential relay.

Figure 4.19 represents external faults.

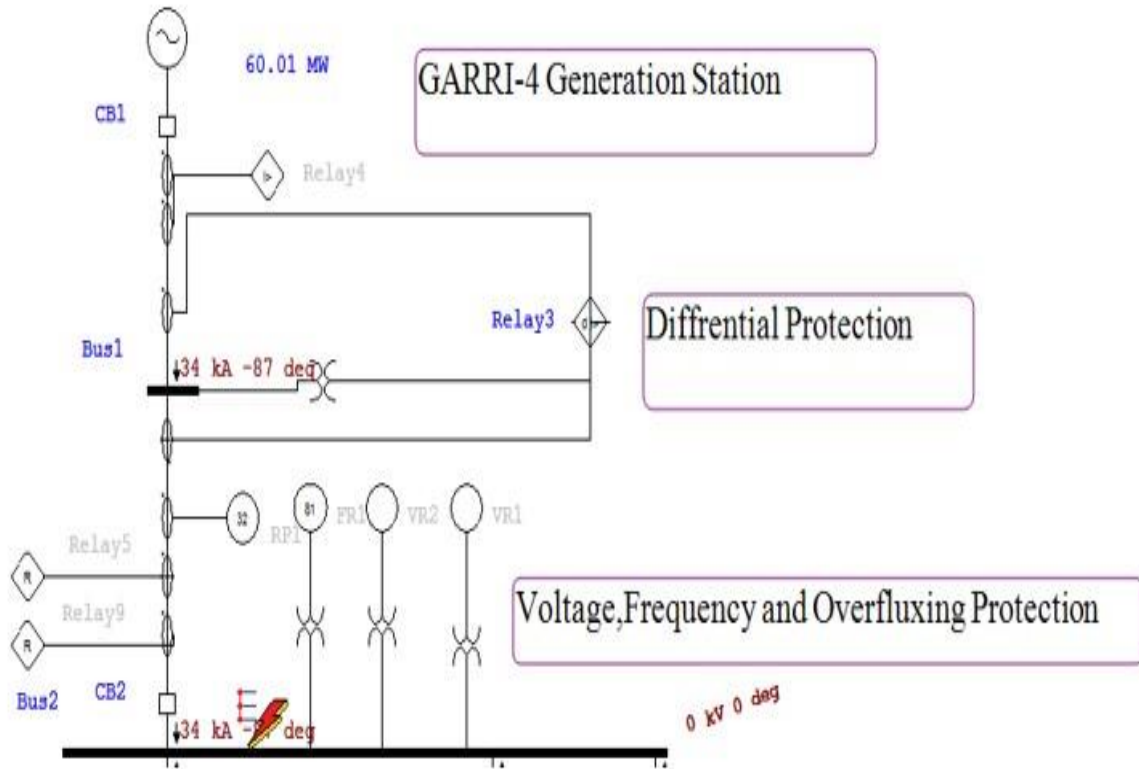

Figure 4.19 External Fault

- The fault occur outside the protected zone bus 1 with the same polarity of CT.

### 4.3.10 Stator Earth Fault Protection

Figure 4.20 represents protection operation of stator earth fault.

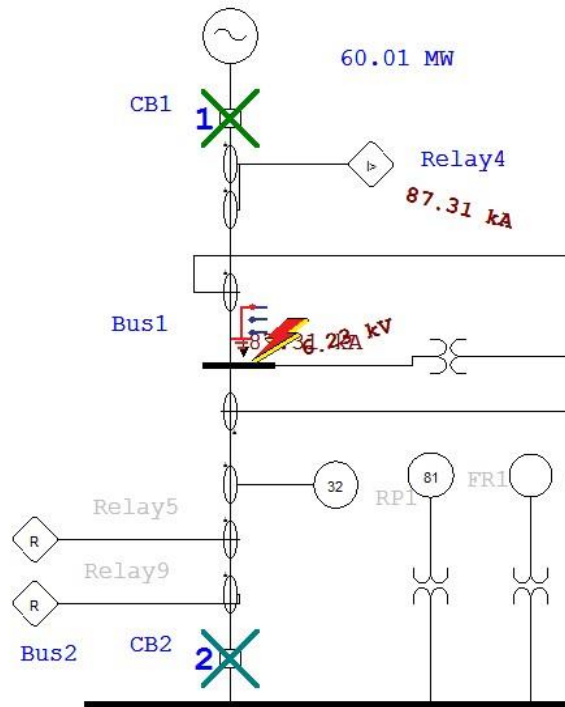

Figure 4.20 Protection Operation of stator Earth Fault

- Stator earth fault event created by choosing line to ground option at bus1 since the fault occurs. Figure 4.2 represents stator earth fault event recorder.

Sequence-of-Operation Events - Output Report: Untitled

Line-to-Ground (Asymmetrical) fault on bus: Bus1

Data Rev.: Base      Config: Normal      Date: 11-10-2017

| Time (ms) | ID     | If (kA) | T1 (ms) | T2 (ms) | Condition                           |
|-----------|--------|---------|---------|---------|-------------------------------------|
| 500       | Relay4 | 87.314  | 500     |         | Ground - OC1 - 51                   |
| 510       | CB1    |         | 10.0    |         | Tripped by Relay4 Ground - OC1 - 51 |
| 510       | CB2    |         | 10.0    |         | Tripped by Relay4 Ground - OC1 - 51 |

Figure 4.21 Stator Earth Fault Event Recorder

- Multifunction relay was used to detects the faulty condition
- CB1 and CB2 trips after 0.01 second.

### 4.3.11 OverCurrent Protection

Figure 4.22 represents protection operation of over current.

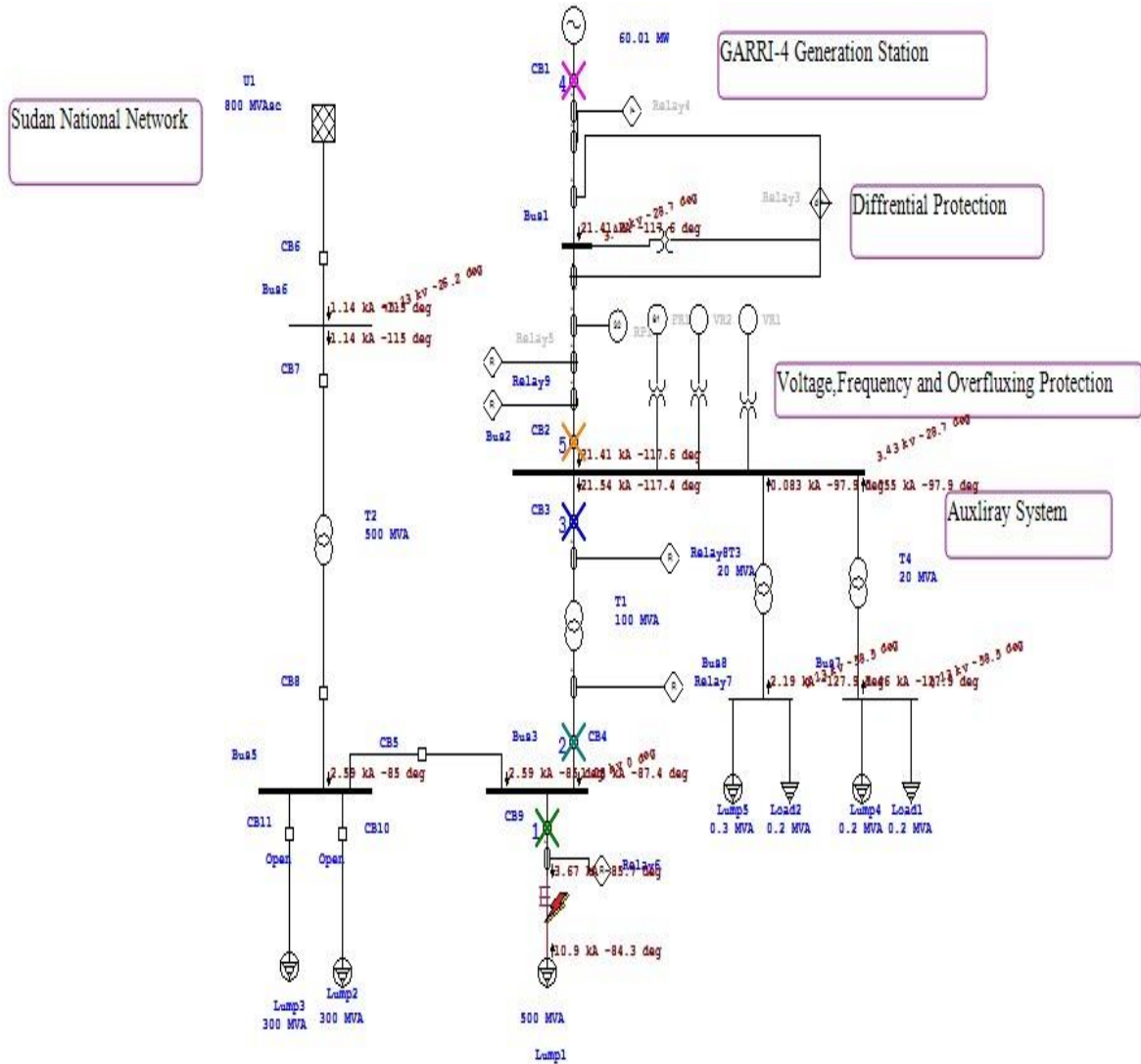

Figure 4.22 Protection operation of Over Current

- For over current protection four relays and CT were used
- Figure 4.23 represents the overcurrent record.

| Sequence-of-Operation Events - Output Report: Untitled                            |        |                |         |                  |  |
|---|--------|----------------|---------|------------------|--|
| 3-Phase (Asymmetrical) fault on connector between CT8 & Lump1. Adjacent bus: Bus3 |        |                |         |                  |  |
| Data Rev.: Base   |        | Config: Normal |         | Date: 11-10-2017 |  |
| Time (ms)   | ID     | If (kA)        | T1 (ms) | T2 (ms)          | Condition                                    |
| 305   | Relay6 | 3.668          | 305     |                  | Phase - OC1 - 51 - Forward                   |
| 315   | CB9    |                | 10.0    |                  | Tripped by Relay6 Phase - OC1 - 51 - Forward |
| 497   | Relay7 | 1.077          | 497     |                  | Phase - OC1 - 51                             |
| 507   | CB4    |                | 10.0    |                  | Tripped by Relay7 Phase - OC1 - 51           |
| 750   | Relay8 | 21.538         | 750     |                  | Phase - OC1 - 51                             |
| 760   | CB3    |                | 10.0    |                  | Tripped by Relay8 Phase - OC1 - 51           |
| 1009  | Relay9 | 21.408         | 1009    |                  | Phase - OC1 - 51                             |
| 1019  | CB1    |                | 10.0    |                  | Tripped by Relay9 Phase - OC1 - 51           |
| 1019  | CB2    |                | 10.0    |                  | Tripped by Relay9 Phase - OC1 - 51           |

Figure 4.23 Over Current Event Record

- CB4, CB3, CB2 and CB1 trip in a sequence order.

#### 4.4 Summary

- The generators starts withdraw reactive power from the system in the event of loss of field. The event will be detected by the reverse power relay which trip the Circuit Breaker. This event is designed using ETAP transient stability analysis by loss of excitation event.

- In reverse power event the direction of the active power reverses. The reverse power relay detects this event and trip the Circuit Breaker. This event was implemented using ETAP by activating loss of excitation for transient stability analysis

- The generator frequency drops when the system is overloaded. Relay measures the frequency of voltage signal given through VT. Under frequency relay detects this event and trip the Circuit Breaker. This event was implemented using ETAP by activating Under Frequency for transient stability analysis.

- Over Frequency event appears when the load is lost or when the generation exceeded the load. Relay measures the frequency of voltage signal given

through VT, over frequency relay trip the Circuit Breaker when the frequency of the system rises above the set value. This event was implemented using ETAP by activating Over Frequency for transient stability analysis.

- Over fluxing event appears when disconnecting a high load. If the percentage V/F increased above the set value the over fluxing relay trips the Circuit Breaker. This event was implemented using ETAP by activating Over Fluxing event for transient stability analysis.

- Overvoltage event appears when the load is suddenly lost. Relay measures the voltage through VT, over voltage relay trip the Circuit Breaker when the voltage of the system rises above the set value. This event was implemented using ETAP by activating over voltage for transient stability analysis.

- Under voltage event occurs when the system is overloaded, so, the generator delivers larger current and the voltage of the system drops. Under voltage relay operates when the voltage of the system goes below the set value. This event is designed using ETAP transient stability analysis by adding a high load.

- The generator voltage drops when the system is overloaded. Relay measures the voltage signal given through VT. Under voltage relay detects this event and trip the Circuit This event is designed using ETAP transient stability analysis by removing a high load.

# **CHAPTER FIVE**

## **CONCLUSION AND RECOMMINDATION**

### **5.1 Conclusion**

Generators are the most important and expensive unites in power system grid. Thus, generator protection must be taken in the consideration.

A real time implementation of multifunctional digital relaying scheme in ETAP for scaled generator is presented in this project. The 3-phase power circuit simulation and prototype implementation of various protection schemes applicable to generator has been carried out.

This project presents a real time implementation of multifunctional digital relaying scheme in ETAP for scaled generator. The 3-phase power circuit simulation and prototype implementation of various protection schemes applicable to generator has been carried out

The developed model is capable of eliminating various type of normal and abnormal faulty condition of generator. Faults protection scheme is designed and implemented to detect all types of faults.

Various type of generator protection was implemented successfully by ETAP programmer with satisfactory result.

### **5.2 Recommendation**

The lack of main and reliability back-up protection schemes in the event of abnormalities and faults, the lack of comprehensive monitoring, the occurrences of abnormalities and faults without protecting the supply units from them is the main reason for instability of power supply.

To make a comprehensive and effective protection for the generation units at GARRI 4, generator protection design scheme must also take into account

some additional considerations to increase the performance of the protection scheme, such as Scheduling maintenance for generation units to avoid frequent outage of the electrical supply, in the event of very sever fault the relay must trip the Circuit Breakers in very short time like what happened in the transient study of over frequency by using ETAB implementation .

Also Study and simulation for generation unit (both generator and its step-up transformer) could be done using protection relays of ETAP software besides online relay testing.

## References

1. Strauss, Cobus. Electrical Network Automation and Communication Systems. 2010.
2. Domin, J. Lewis Blackburn and Thomas J. Protective relaying principle and applications. 1991.
3. Electric, Schneider. Network protection and automation guide. 2014.
4. P. M. Anderson, "Power System Protection ", IEEE Press power engineering series. Mc Graw Hill New York, second addition, 2012.
5. . L.G.Hewitson Mark Brown ,Ramesh Balakrishnan , “ Practical power system protection” first published 2004,copy right 2004,Linacre house ,jordan hill ,oxford OX2 8DP.
6. J.B. Gubta, "Switchgear and Protection", S.K. Kataria & Sons, India, New Delhi, Third Edition, 2013.
7. GARRI4 MANUAL. 2008.





# APPENDIX A

## Voltage Relay Setting

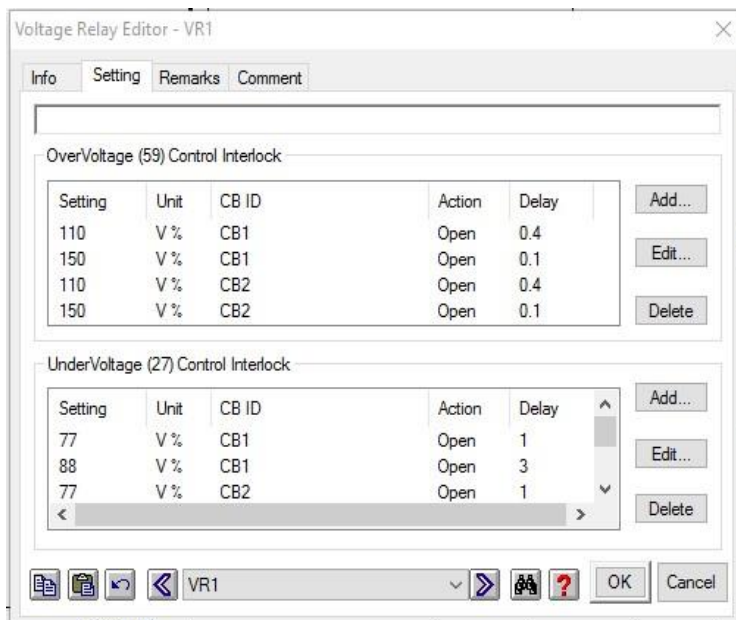

Figure A-1

## Reverse Power Relay Setting

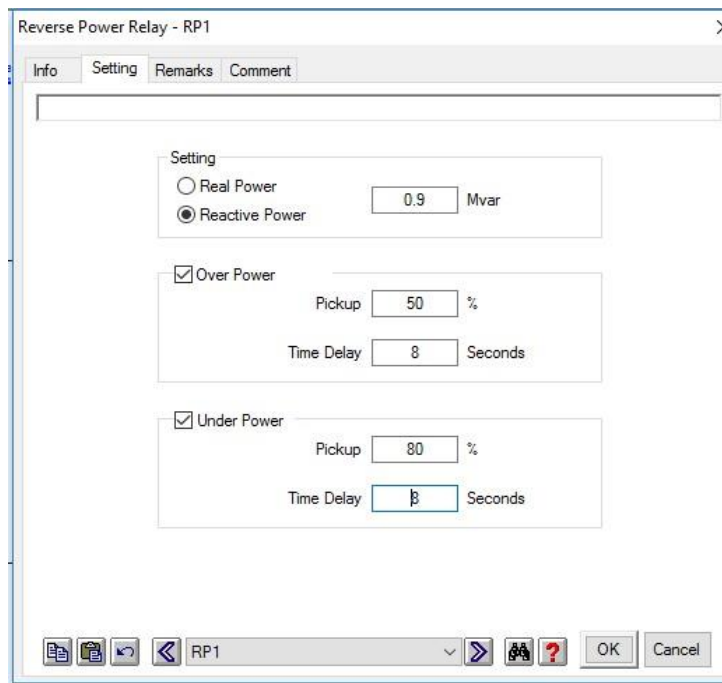
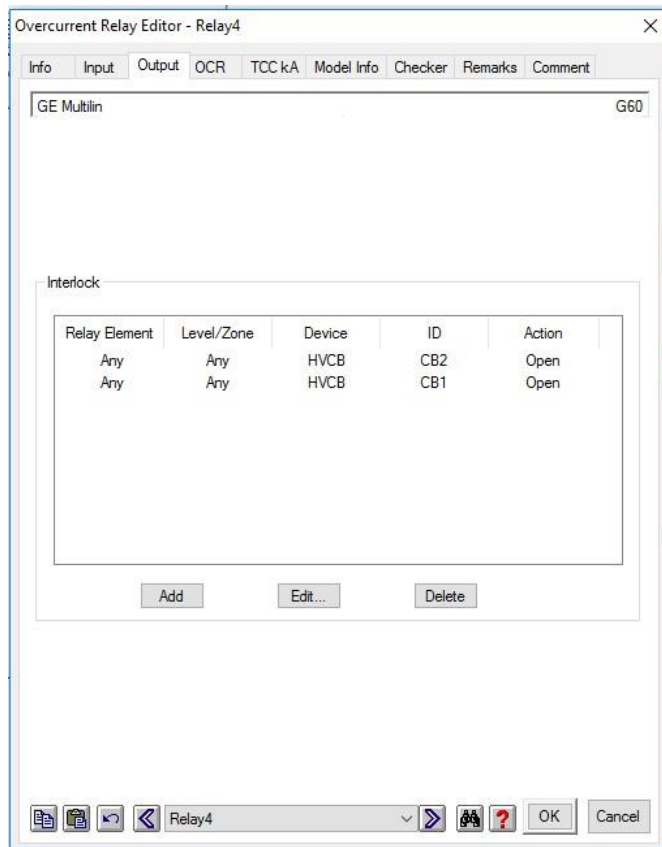

Figure A-2

## Negative Sequence setting



**Figure A-3**

## Negative Sequence Relay Setting

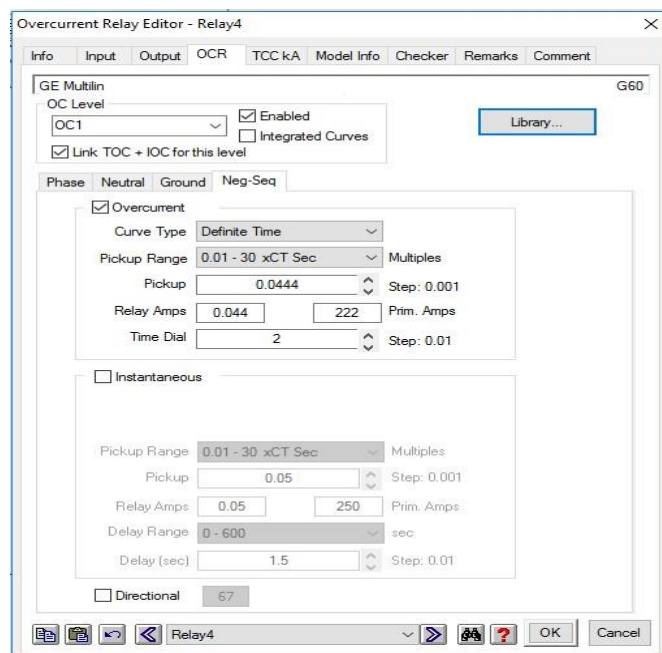

**Figure A-4**

## Over fluxing Setting

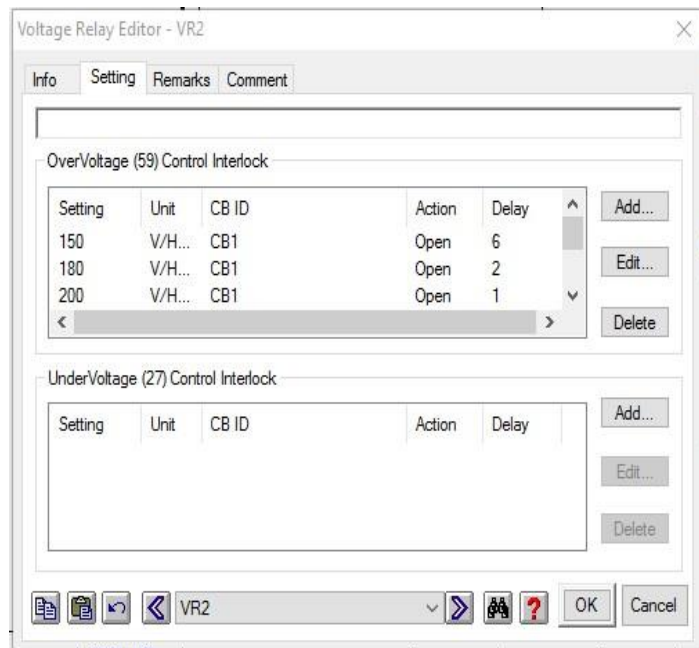

**Figure A-5**

## Differential Relay Setting

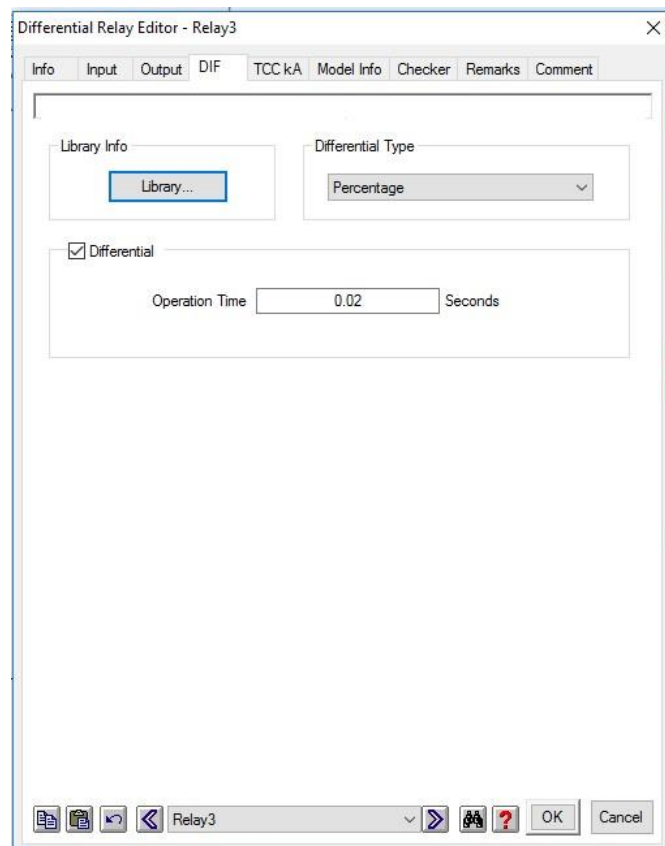

**Figure A-6**

## Frequency Relay Setting

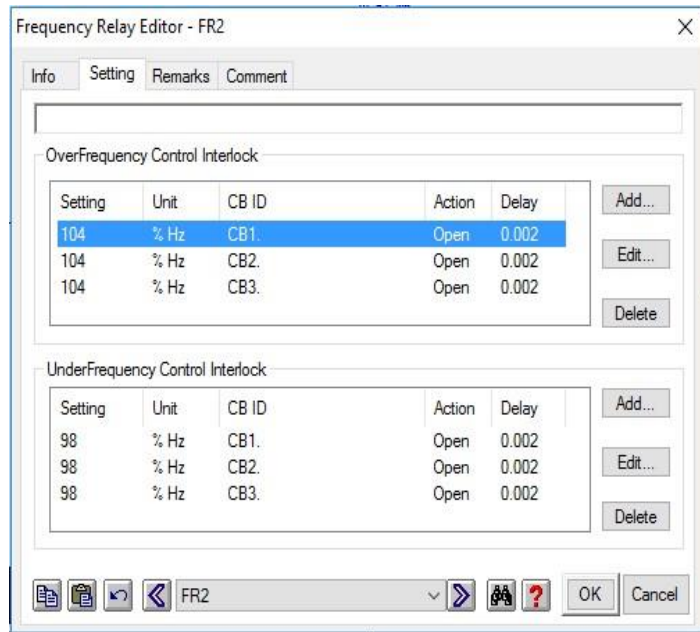

**Figure A-7**

## Stator Earth Fault Relay Setting

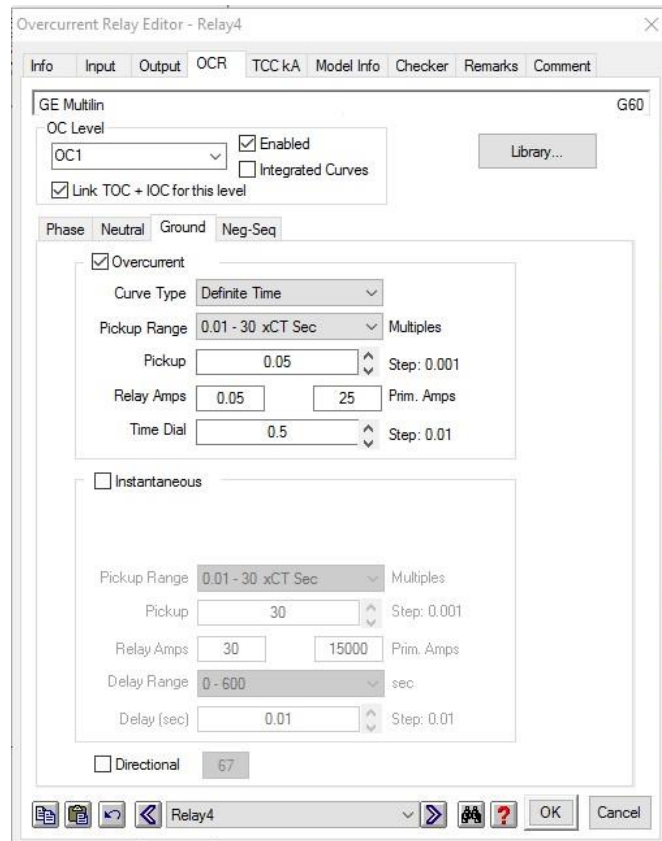

**Figure A-8**

## Stator Earth Fault Setting

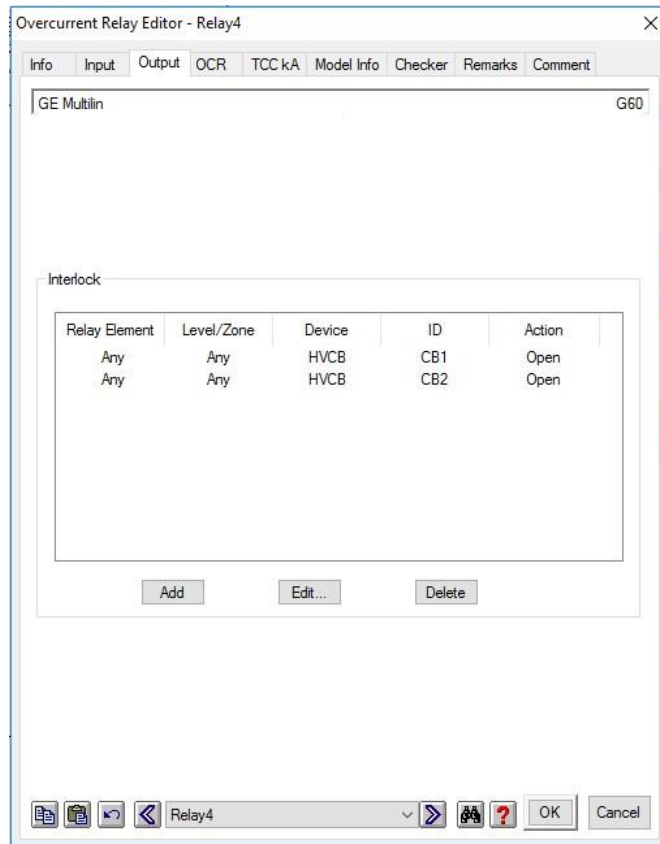

Figure A-9