



**SUDAN UNIVERSITY OF SCIENCE AND  
TECHNOLOGY  
COLLEGE OF COMPUTER SCIENCE &  
INFORMATION TECHNOLOGY  
COMPUTER SYSTEMS AND NETWORKS  
DEPARTMENT**

# **VIDEO CONFERENCE SYSTEM USING WEBRTC**

**نظام مؤتمرات الفيديو باستخدام تقنية WEBRTC**

THESIS SUMMITTED AS A PARTIAL REQUIREMENTS OF B.Sc. (HONOR)  
DEGREE IN COMPUTER SYSTEMS AND NETWORKS

OCTOBER, 2017



بِسْمِ اللَّهِ الرَّحْمَنِ الرَّحِيمِ

**SUDAN UNIVERSITY OF SCIENCE AND  
TECHNOLOGY  
COLLEGE OF COMPUTER SCIENCE &  
INFORMATION TECHNOLOGY  
COMPUTER SYSTEMS AND NETWORK  
DEPARTMENT**

**VIDEO CONFERENCE SYSTEM USING  
WEBRTC**

**نظام مؤتمرات الفيديو باستخدام تقنية WEBRTC**

**THESIS SUMMITTED AS A PARTIAL REQUIREMENTS OF B.Sc. (HONOR)  
DEGREE IN COMPUTER SYSTEMS AND NETWORKS**

**PROPOSED BY:**

**Abrar Adil Abd Elmoula**

**Alaa Bashir Abd Aljabar**

**Tarig Mohammed Taha**

**SUPERVISOR:**

**Intsar Ibraheem Ahmed Alhaj**

**DATE**

...../...../.....

**SUPERVISOR SIGNITUR**

# الآية

قال تعالى:

(يَرْفَعُ اللَّهُ الَّذِينَ آمَنُوا مِنْكُمْ وَالَّذِينَ أُوتُوا الْعِلْمَ دَرَجَاتٍ  
وَاللَّهُ بِمَا تَعْمَلُونَ خَبِيرٌ)

صدق الله العظيم

سورة المجادلة (11)

# الحمد لله

الحمد لله في سري وفي علني والحمد لله في حزني وفي سعدي الحمد لله عمّا كنت أعلمه والحمد لله عمّا غاب عن خلدي.

اللهم إنا نحمدك ونشكرك على إكمال هذا العمل، اللهم لك الحمد حتى ترضى ولك الحمد إذا رضيت ولك الحمد بعد الرضى ولك الحمد على كل حال.

نحمد الله الذي فضلنا على كثير من خلقه وانعم علينا بنعمة العقل وزودنا بأدوات العلم ومهد لنا الطريق لإتمام هذا البحث العلمي المتواضع الذي نأمل من المولى عزوجل ان يكون ذا جدوى لما أخرج له.

# Dedication

*To*

*My mother*

*A strong and gentle soul who taught me to trust in Allah,  
believe in hard work and that so much could be done with  
little.*

*My father*

*For earning an honest living for us and for supporting and  
encouraging me to believe in my self*

*My brothers and sisters*

*For being my guardian my educational career and being my  
first teacher*

# Acknowledgement

At the beginning and in the end all thanks belong to **ALLAH**, thanks to the wisdom and perseverance that he has been bestowed upon us during this research, and indeed, throughout our life, we can do everything through him who gives us strength.

We are grateful to our supervisor **Intsar Ibraheem Ahmed Alhaj** for making this research possible. Her support, guidance, advice throughout the research, as well as her painstaking effort in proof reading the drafts, is greatly appreciated. Indeed, without her guidance, we would not be able to put the topic together or complete this project.

Finally, we would like to thank every teacher who have taught, college of computer science and information technology, Sudan University of science and technology, family, friends and everyone how help or support us to reach this stage thank you.

# Abstract

The tremendous development in the means of communication has effectively contributed to reducing travel effort and mobility between different areas of the meeting, educational, health, etc.

The aim of the study is to create a video conferencing system using (WebRTC) technology.

Our findings after designing the web-based video conference system users can create a video conference or join an existing video conference. They can also record and keep this conference, share files, take attendance, share desktop and chat with conference members.

Video conferences contribute to the preparation and advancement of our country like other developed countries.

The study recommended a set of recommendations:

completing the web site by linking it to the cloud storage and connecting it to the billing system, integrate it with social media.



## المستخلص

ان التطور الهائل في وسائل الاتصال ساهم بفعالية في تقليل جهد السفر والتنقل بين المناطق المختلفة للاجتماع أو الدراسة أو غيرها.  
ان مؤتمرات الفيديو تساهم في تحضر ورقي بلادنا كباقي الدول المتقدمة.  
الهدف من الدراسة هو عمل نظام مؤتمرات فيديو ذات جودة باستخدام تقنية (WebRTC) .

النتائج التي توصلنا إليها بعد تصميم الموقع الالكتروني هي:  
يمكن للمستخدمين انشاء مؤتمر فيديو أو الانضمام لمؤتمر فيديو موجود، كما يمكن تسجيل هذا المؤتمر والاحتفاظ به، ومشاركة الملفات و مشاركة سطح المكتب واخذ الحضور والردشة مع اعضاء المؤتمر. كما أوصت الدراسة بمجموعة من التوصيات هي تكملة الموقع بربطه بوحدة التخزين السحابية وربطه بنظام دفع الفواتير وربطه بمواقع التواصل الاجتماعي.

## Table of Terms

Term	Description
API	Application Programming Interface
CSS	Cascading Style Sheet
HTML	Hypertext Markup Language
JS	Java Script
OSI	Open System Interconnection
PYPL	Python Package Index
RDBMS	Relational Database Management Systems
SRTP	Secure Real-Time Transport
UML	Unified Modeling Language
URL	Uniform Resource Locator
VOIP	Voice Over Internet Protocol
WEBRTC	Web Real Time Communication
XML	Extensible Markup Language

# List of Content

List of Figures.....	xi
List of Tables.....	xiii
Chapter One.....	1
Introduction.....	1
1.1 Introduction.....	2
1.2 Problem Statement.....	2
1.3 Suggested Solution.....	2
1.4 Objectives.....	3
1.5 Scope.....	3
1.6 Importance.....	3
1.7 Structure.....	4
Chapter Two.....	5
Literature Review.....	5
2.1 Introduction.....	6
2.2 Background.....	6
2.3 WebRTC.....	6
2.3.1 WebRTC Advantages.....	6
2.4 Some Video Conferencing Systems.....	7
2.4.1 Video Link 2me.....	7
2.4.2 Veeting Rooms.....	7
2.4.3 Q audio Conf.....	8
2.4.4 Cisco Webex Meeting.....	8
2.4.5 Click meeting.....	8
2.5 previous Studies.....	9
2.5.1 WebRTC Video and Telehealth.....	9
2.5.2 WebRTC in education.....	10
2.6 Comparison between Video Conferencing Systems.....	11
2.7 Conclusion.....	12
Chapter Three.....	13

System Analysis and Design .....	13
3.1 Introduction.....	14
3.2 System Description.....	14
3.3 System Environment.....	14
3.4 System Functionality .....	15
3.4.1 System Administrator and User Functions .....	15
3.4.2 System Administrator Functions .....	15
3.4.3 System user Functions .....	16
3.4.4 System Nonfunctional Requirement.....	17
3.5 System Components .....	18
3.6 System analysis and design using UML.....	19
3.7 Database Analysis.....	19
Chapter Four .....	38
Implementation and Tools .....	38
4.1 Introduction.....	39
4.2 Home Interfaces.....	39
4.3 System Administrator Interface.....	40
4.4 System User Interface.....	43
4.5 Tools and Techniques .....	50
4.5.1 UML (Unified Modeling Language) .....	50
4.5.2 Python .....	51
4.5.2.1 Python Advantages .....	51
4.5.3 Django.....	52
4.5.3.1 Django advantages.....	52
4.5.4 WebRTC.....	52
4.5.4.1 WebRTC Advantages .....	53
4.5.5 SQLite.....	53
4.5.5.1 SQLite Advantages .....	54
4.5.6 Bootstrap.....	54
4.6 Conclusion .....	54
Chapter Five.....	55
Results, Conclusion and.....	55

Recommendations.....	55
5.1 Introduction.....	56
5.2 Results.....	56
5.3 Conclusion .....	56
5.4 Recommendations.....	57
References.....	58
Appendices .....	60

# List of Figures

Figure 3.1 System environment.....	15
Figure 3.2 General use case diagram.....	19
Figure 3.3 Use case diagram create join communication.....	20
Figure 3.4 Use case diagram for add operation.....	21
Figure 3.5 Use case diagram for delete operation.....	21
Figure 3.6 Use case diagram for view operation.....	22
Figure 3.7 Use case diagram for share operation.....	23
Figure 3.8 Use case diagram for call operation.....	23
Figure 3.9 Sequence diagram for add user.....	24
Figure 3.10 Sequence diagram for register operation.....	25
Figure 3.11 Sequence diagram for login operation.....	25
Figure 3.12 Sequence diagram for share file.....	26
Figure 3.13 Sequence diagram for share desktop.....	27
Figure 3.14 Sequence diagram for record.....	27
Figure 3.15 Sequence diagram for delete user.....	28
Figure 3.16 Sequence diagram for create room operation.....	29
Figure 3.17 Sequence diagram for join room operation.....	29
Figure 3.18 Sequence diagram for chat.....	30
Figure 3.19 Sequence diagram for call.....	31
Figure 3.20 Sequence diagram for attendance.....	32
Figure 3.21 Sequence diagram for view users.....	32
Figure 3.22 Activity diagram for system.....	33
Figure 3.23 Activity diagram for admin.....	34
Figure 3.24 Activity diagram for creator.....	35
Figure 3.25 Activity diagram for joiner.....	36
Figure 4.1 Home interface.....	39
Figure 4.2 Administrator's login interface.....	40
Figure 4.3 Add new user.....	41
Figure 4.4 User's database.....	41
Figure 4.5 Delete user.....	42
Figure 4.6 Confirm delete.....	42
Figure 4.7 Successful delete.....	42
Figure 4.8 Signup.....	43
Figure 4.9 Login.....	44
Figure 4.10 Create room.....	44
Figure 4.11 Join room.....	45
Figure 4.12 Permissions.....	45

Figure 4.13 Video and voice call.....	46
Figure 4.14 Share file .....	47
Figure 4. 15 Download shared file .....	47
Figure 4. 16 Chat .....	48
Figure 4. 17 Share desktop permission.....	48
Figure 4. 18 Share desktop .....	49
Figure 4. 19 Voice record .....	49
Figure 4. 20 Video record.....	50

# List of Tables

Table 2.1 Comparison between video conferencing systems.....	12
Table 4.1 Users .....	36
Table 4.2 Rooms .....	37
Table 4.3 Rooms members .....	37



# **Chapter One**

## **Introduction**

# 1.1 Introduction

People are often asked to go to meetings, attend or give lectures from a geographically distant site, away from their own institution or organization. Distance, costs and the duration of the journey are frequently a source of discouragement to attend such meetings or even courses. Videoconferencing has emerged as a most successful solution.

Videoconferencing means to conduct conference between two or more participants at different sites to transmit audio and video.

As the two participants speak to one another, their voices are carried over the network and delivered to the other's speakers, and whatever images appear in front of the video camera appear on the other's device.

Videoconferencing uses audio and video telecommunications to bring people at different sites together. This can be as simple as a conversation between people in private offices or involve several sites in large rooms at multiple locations.

# 1.2 Problem Statement

With the rapid development of technology especially maturity of video conferencing, more companies select video conferencing as their daily communication tool with their colleagues, customers, friends and partners in a convenient and effective way. The current systems do not contain all features and lack of attendance feature.

# 1.3 Suggested Solution

Develop web-based system provide real time communication between participants with desired features such as:

1. Video calls.
2. Voice calls.
3. Share desktop.
4. Share files.
5. Video recording.

6. Audio recording.
7. Group chat.
8. Attendance.

## **1.4 Objectives**

This research aim to:

- Provide video conference system.
- Provide video conference system with attendance.
- Record video session in different format.
- Reduces physical effort by using this video conference system instead of real meeting.

## **1.5 Scope**

Develop web-based system and provide the following features as needed by customers:

- Voice and video calls.
- Share desktop.
- Share files.
- Voice and video record.
- Group chat.
- Attendance.

## **1.6 Importance**

This project can be considered of great importance. That is because other video conferencing systems may be specialized where as it is general.

The system can be used in:

- Social communication.
- Education.
- Health care.
- Business.
- Any other fields.

## **1.7 Structure**

This research consists of five chapters, as follows: chapter one introduction, chapter two literature review, chapter three system analysis and design, chapter four implementation and tools and chapter five results, conclusion and recommendation.

**Chapter Two**  
**Literature Review**

## 2.1 Introduction

This chapter contains background of research also, discuss the WebRTC technology and its benefits, previous studies, show some video conference systems, and compare them.

## 2.2 Background

Old video conferencing systems needed many separated technologies like wideband codecs (voice and video), echo cancellation, automatic gain control, noise reduction, dynamic jitter buffers, network traversal, peer-to-peer protocols and session setup to make it work. However, new technologies like WebRTC is free from these defects.

The aim of WebRTC is to bring all this technology into the browser. Many of these solutions require users to install plugins or applications on their PCs and mobile devices. They also require developers to pay for licensing, creating a huge barrier and deterring new companies to join this space. With WebRTC, the focus is on enabling this technology for every browser user without the need for plugins or hefty technology license fees for developers.

## 2.3 WebRTC

WebRTC (web real time communication) is collection of communications protocols and application programming interfaces that enable real time communication over peer-to-peer connections [1] [2].

It gives us rich and high-quality video streaming via JavaScript APIs.

### 2.3.1 WebRTC Advantages

With today's economy, it is even more important for business to embrace WebRTC as part of their initiative to reduce costs and remain effective and

competitive. WebRTC APIs is supported by most leading Browsers for Windows (Google Chrome, Firefox and Opera) [3].

- WebRTC is an open-source application-programming interface (API).
- WebRTC enabled browser with any operating system and a web services application can direct the browser to create a real-time voice or video connection to another WebRTC device or to a WebRTC media server.
- Always-on voice and video encryption. The Secure Real-time Transport protocol (SRTP) is used for encryption and authentication of both voice and video.
- WebRTC give advanced voice and video quality.
- WebRTC supports reliable session establishment.
- WebRTC supports the negotiation of multiple media types and endpoints.

## **2.4 Some Video Conferencing Systems**

There are many video conferencing systems such as Video Link 2me, Veeting Rooms, Q audio Conf, Cisco Webex Meeting, Click meeting and Ring Central.

### **2.4.1 Video Link 2me**

Videolink2.me is online video calling conferences service use WebRTC technology, which allows users to communicate via instant messaging and video chat in real-time. The website provides the ability to make a video call with up to 5 people at the same time, share screen to conference participants, record and send video messages [4].

### **2.4.2 Veeting Rooms**

Veeting Rooms is a business solution offering a virtual meeting environment use WebRTC technology. In addition to audio and video conferencing, Veeting Rooms includes collaboration functionalities to take your

meetings virtual: business-class slideshow presentation, document sharing, text chat, and other tools. Veeting.com is designed for quick video-meetings to work with anyone with no registration or sign-ups. Veeting Rooms is completely browser-based and does not require any software downloads to run. You schedule meetings just up to 30 minutes for free [5].

### **2.4.3 Q audio Conf**

QCONF conference calls service offer secure, high-quality international audio conferencing at the most cost-effective solution available use WebRTC technology. Audio conferencing through reliable local access numbers in over 50 countries across the globe. No matter how many people join or for how long you talk, still only pay one flat rate per conference call. Scheduling & meeting management from easy-to-use web and mobile apps [6].

### **2.4.4 Cisco Webex Meeting**

Cisco WebEx is often described as a flexible audio and video conferencing solution designed for businesses of all sizes, Cisco WebEx has the capability to hold multiple meetings providing users a real-time experience, this web conferencing software is also highly recommended for large-scale product launches and educational sessions [7].

### **2.4.5 Click meeting**

Click Meeting designed to make online meetings very productive. Designed to connect people regardless of location, operating system, or time zone. Presenters and attendees can easily link with each other and start meetings or deliver presentations, share YouTube videos, or share the screen to get their point across a browser-based web conferencing tool with features [8].

### **2.4.6 Ring central**



RingCentral Meetings is a web conferencing solution with video conferencing, collaborative screen sharing, and large-scale webinars. Hold face-to-face meetings, share your desktops, applications, or whiteboard and engage with large audiences in virtual events [9].

## **2.5 previous Studies**

The following sections illustrate some researches about the effect of WebRTC technology in health and education.

### **2.5.1 WebRTC Video and Telehealth**

This paper examines the inherent security advantages of a telehealth application based on WebRTC video technology. The authors also draw on their experience in WebRTC and telehealth application development to share the challenges of building a secure application, and considerations you need to make when stepping into this exciting and rapidly changing area of healthcare innovation [10].

#### **2.5.1.1 Advantages of using health care application**

The following are advantages of using health care application:

- Mental health care
- Follow up visits
- after surgery
- Patient education
- sessions
- Group visits Nutritionist
- assessments
- Remote consultation
- with specialists
- Chronic disease
- care management

WebRTC common use case in telehealth is remote communication between a doctor and patients in a secure and easy way without the need of installing an application or plugins, and many other features like:

- Follow-up visits
- Pre-screening
- Remote experts
- In home care

WebRTC in health care:

WebRTC is widespread enough now that healthcare enterprises are beginning to adopt it to leverage the many benefits of telehealth for patients and care providers. Security will always be a concern in any healthcare application. WebRTC offers some inherent security advantages that make it attractive to telehealth application developers. The encrypted communications and Peer-to-Peer architecture make it more attractive than commercial off-the-shelf video conferencing solutions. With the addition of media servers, it can also scale to larger conversations and offer enhanced features [10].

## **2.5.2 WebRTC in education**

This paper was published on 2015 and proposes a collaborative system based on WebRTC technology to improve digital universities e-Learning environment. It allows an easy way for communication via web browsers between teachers and students using video, voice calls and chat. It also supports file transfer and screen sharing.

The goal is to provide a simple E-learning system with high quality and without the need of installing a program.

WebRTC technology helps to provide the following features to the e-learning system according to the type of profile:

- Management of users, classes and courses.
- Courses planning.
- Screening and monitoring of distance learning via Videoconferencing.
- Real-time File Transfer (lectures, exercises).

- Teacher's screen sharing toward students.
- Instant messaging between teachers and students.
- Deactivation and reactivation request from user's webcam in the middle of conversation session.

WebRTC was used to support higher education in the context of the student population massification of universities with a non-existent Internet access or limited Internet bandwidth [11].

## **2.6 Comparison between Video Conferencing Systems**

These is a Comparison between features of video conferencing systems such as free trial, Group chat, Audio calls, Video calls, Attendance, Share desktop, Social media integration, Record audio, Record video, Record video.

Most of the systems have share desktop, audio calls (except Video link 2 me), video calls (except Q conf), half of these systems have record videos, three of them don't have Record audio and all of the systems lack of attendance feature [12], as shown in table(2.1).

Table 2.1 Comparison between video conferencing systems

Name	Ring central	Click meeting	Join me	Adobe connect	Amazon chime	Cisco webex	Go to meeting	E voice	Zoho meeting	Video link 2 me	Veeting rooms	Q conf
Group chat	✓	✓	✓	✓	✓	✓	✓	✓	✓	✓	✓	✓
Audio calls	✓	✓	✓	✓	✓	✓	✓	✓	✓	✗	✓	✓
Video calls	✓	✓	✓	✓	✓	✓	✓	✓	✓	✓	✓	✗
Attendance	✗	✗	✗	✗	✗	✗	✗	✗	✗	✗	✗	✗
Share desktop	✓	✓	✓	✓	✓	✓	✓	✓	✓	✓	✓	✓
Record audio	✓	✓	✓	✓	✓	✓	✓	✓	✗	✗	✗	✓
Record video	✓	✓	✓	✗	✓	✓	✗	✓	✗	✗	✗	✗

## 2.7 Conclusion

This chapter transacted with background of research also, dealt with WebRTC technology and its benefits, previous studies and some video conference systems with comparison.

# **Chapter Three**

## **System Analysis and Design**

## **3.1 Introduction**

This chapter discuss a general description of the system and its functions and clarifies the system components, and deals with detailed analysis of the operations of the system using the schemes UML and database.

## **3.2 System Description**

Video conferencing system that provides to the administrator the ability to delete users also view rooms.

It' provides to the user after registration two options create or join room.

Create room option will create a unique room key the user can use it or writes his own key the system will check if its unique and after a permission will be shown to user to allow the system to use the camera and microphone, user can allow both or deny.

Join room option will ask the user to enter the room key and if the room was found all the system functions (chat, record, share desktop and share file) will appear to the joiner user with a special feature (attendance) that will only appear to the room creator.

## **3.3 System Environment**

WebRTC is setup peer-to-peer connection between peers, to do that, we need a signaling server to complete the handshake among peers after that peers can use JavaScript APIs to share media between them as shown in figure (3.1).

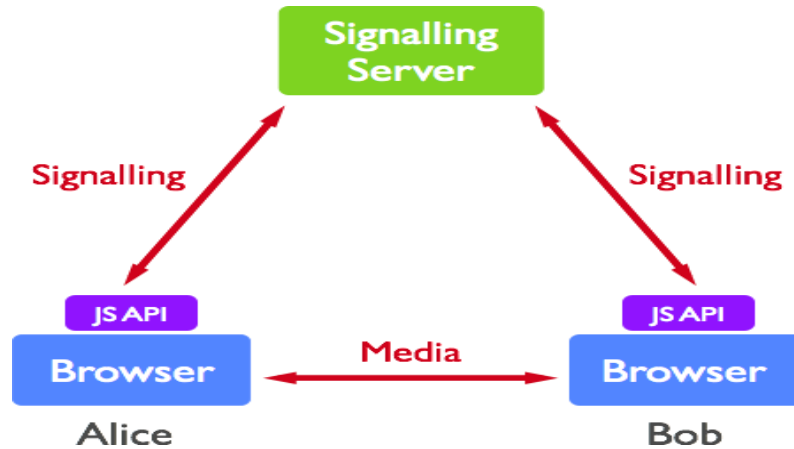

Figure 3.1 System environment

## 3.4 System Functionality

The system divides users according to their authority into two roles:

1. Administrator: we mean by administrator the person who has ability to view, delete users and rooms through the web page.
2. User: the user is the person who create or join session.

### 3.4.1 System Administrator and User

## Functions

There is only one common function between administrator and user Login operation that allows the system administrator or user to login into web page by entering username and password.

### 3.4.2 System Administrator Functions

The administrator have many function such as: add users or rooms, view users or rooms and delete users and room.

- **Add users**

This function allows the administrator to add new user to the system.

- **Add rooms**

It allows the administrator to add new room to the system.

- **View users**

This function allows the administrator to view all registered users in the system.

- **View rooms**

It allows the administrator to view all rooms that were created.

- **Delete user**

This function allows the administrator to delete any user from the system.

- **Delete room**

This function allows the administrator to remove any saved room from the system.

### 3.4.3 System user Functions

The system user have many function such as: sign up, create room or join room, voice or video call, chat, share files or desktop and voice or video record.

- **Sign up**

It allows the system administrator or user to sign up into the application by entering email, username and password.

- **Create a room**

This function allows the user to create a room that have a unique key.

- **Join a room**

This function asks the user to enter a room key and connect the user to other users on this room.



- **Voice call**

This function allows the user to connect to users on the same room through a voice call.

- **Video call**

This function allows the user to connect to users on the same room through a video call.

- **Chat**

This function allows the users to communicate using text messages in a group.

- **Share a desktop**

This function allows the user to share screen content to other users on the same room.

- **Share a file**

This function allows the user to share any type of file with other users on the same room.

- **Voice record**

This function allows the user to record the ongoing session in voice and save the record directly to the user system.

- **Video record**

This function allows the user to record the ongoing session in video and save the record directly to the user system.

### **3.4.4 System Nonfunctional Requirement**

The system has many nonfunctional requirements such as portability, security, and availability.

- **Portability**

The users shall be able to use the system from anywhere on any operating system.

- **Security**

WebRTC has a big advantage over most VoIP services in the security area. Until now, most services have typically treated security as optional, but as WebRTC forbids unencrypted communication, users can be assured that their data remains safe and private.

It encourages WebRTC developers to also take their security seriously.

The main premise of having encryption by default is that a call is private always. Security and encryption are no longer considered to be optional features.

- **Availability**

The service is to be available to all users at any time.

## **3.5 System Components**

The System components are divided into two categories, hardware and software.

### **System hardware Components**

The hardware divided into two device:

- **Server device**

The server device should be at least a core I3 device and has a 4 gigabyte ram.

- **User device**

The computer device must contains a camera, microphone and speaker.

### **System Software Components**

The software divided into two parts:

- **User Part**

This section uses any operating system (windows or Linux) with a browser that support WebRTC technology and requires access to the Internet.

- **Administrator Part**

Is a database that stores information about users and rooms, it was created using SQLite.

## 3.6 System analysis and design using UML

### 3.6.1 General usecase for system

The video conference system consists of three actors: admin, room creator and room joiner.

The admin can do many operations such as: add, view and delete, both room creator and room joiner can create or join a room, the room creator has special operation to view attendance.

All operations in the system require login, to login you must have a registered account. All these operations are an illustrated in figure(3.2)

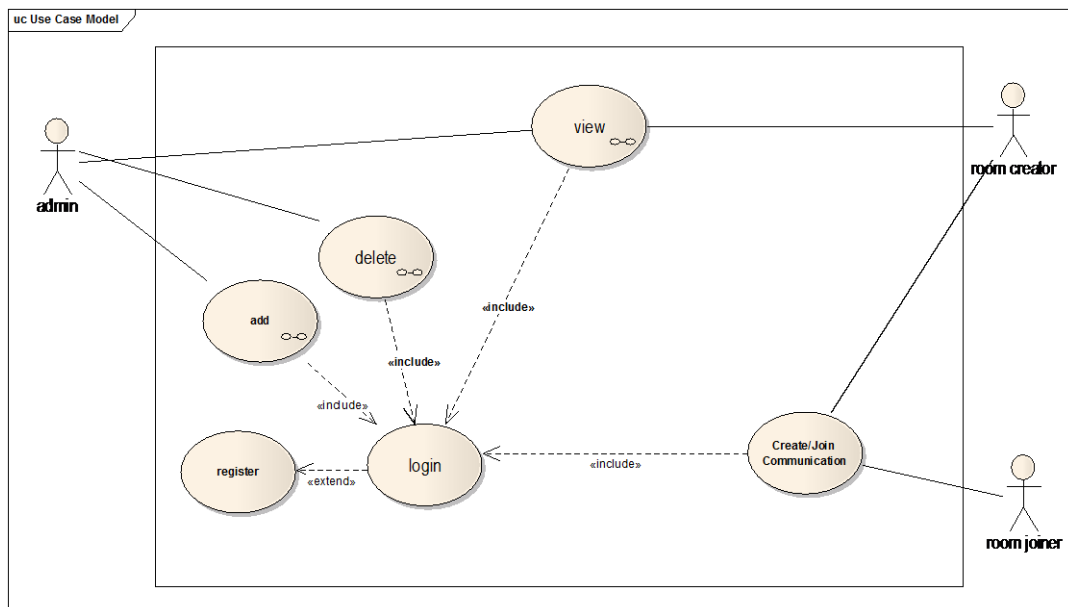

Figure 3.2 General use case diagram

## 3.6.2 Usecase for Create/ Join

### Communication

The room creator and room joiner in create or join room operation can make share, chat, call and record. This illustrated in figure (3.3).

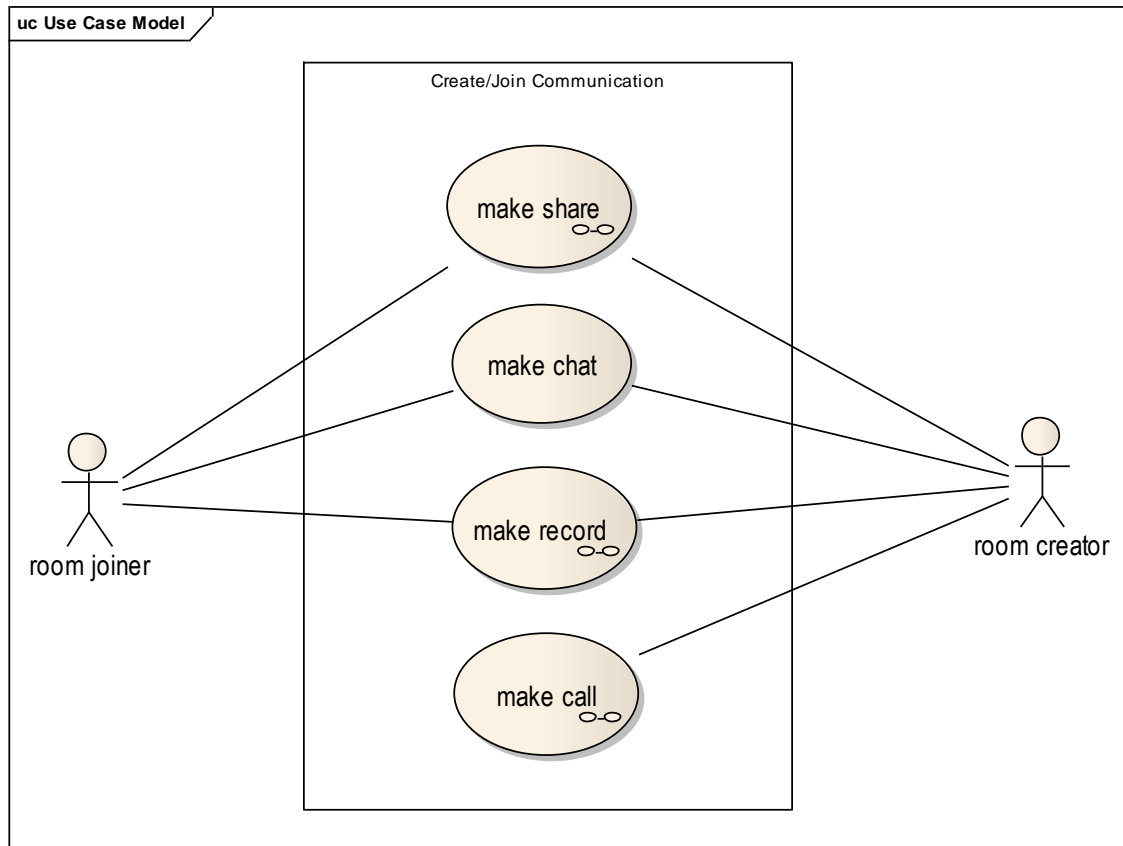

Figure 3.3 Use case diagram create join communication

## 3.6.3 Usecase for add operation

The admin can add new user or room to the system. This illustrates in figure(3.4).

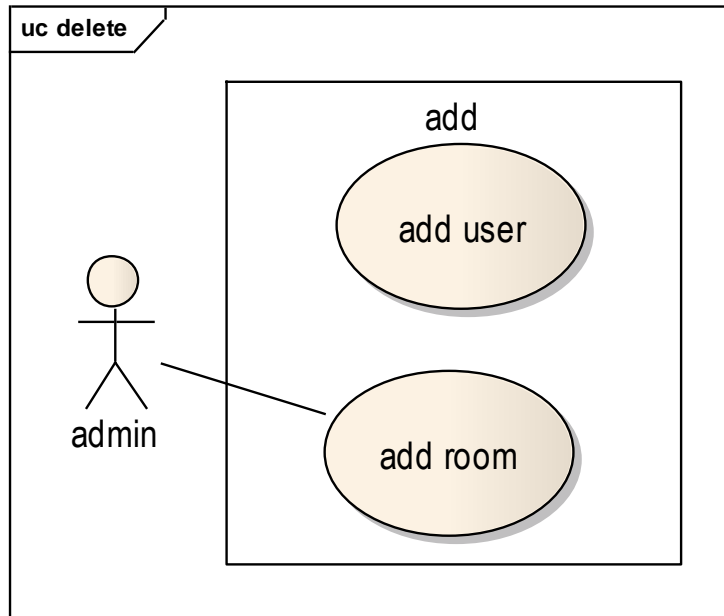

Figure 3.1 Use case diagram for add operation

### 3.6.4 Usecase for delete operation

The admin can delete existing user or room from the system. This illustrates in figure (3.5).

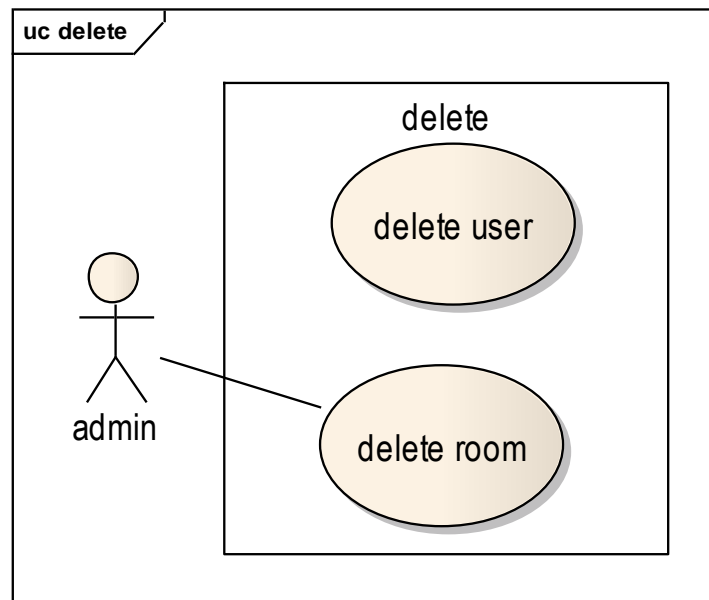

Figure 3.2 Use case diagram for delete operation

## 3.6.5 Use case for view operation

The admin can view all rooms and users in the system, room creator can view all room joiners (attendance). This illustrates in figure (3.6).

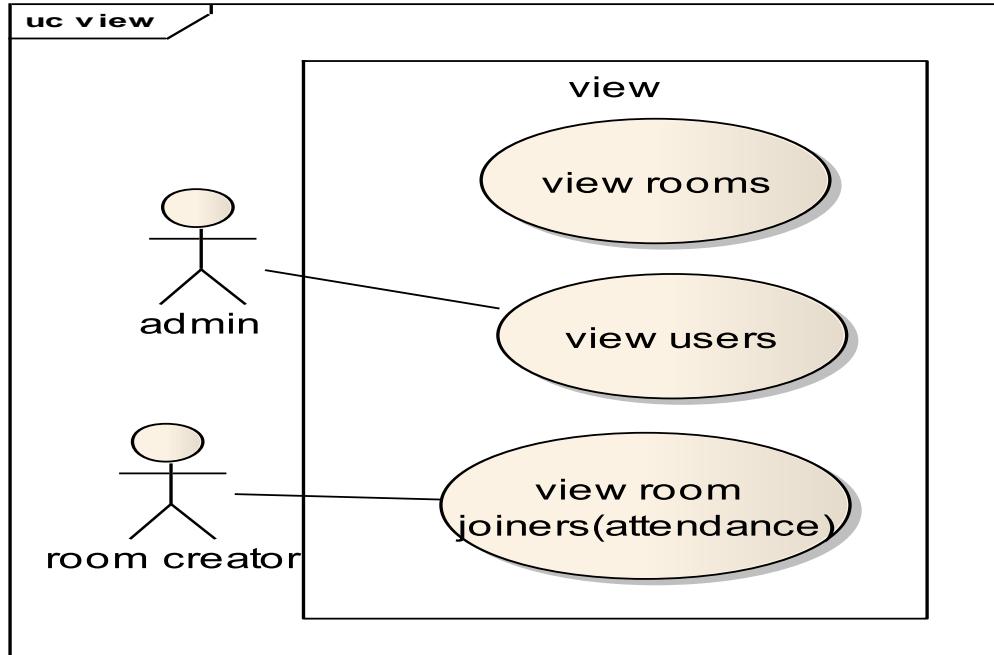

Figure 3.3 Use case diagram for view operation

## 3.6.6 Use case for share operation

The room creator and room joiners can share their desktop with each others also, can share files. This illustrate in figure (3.7).

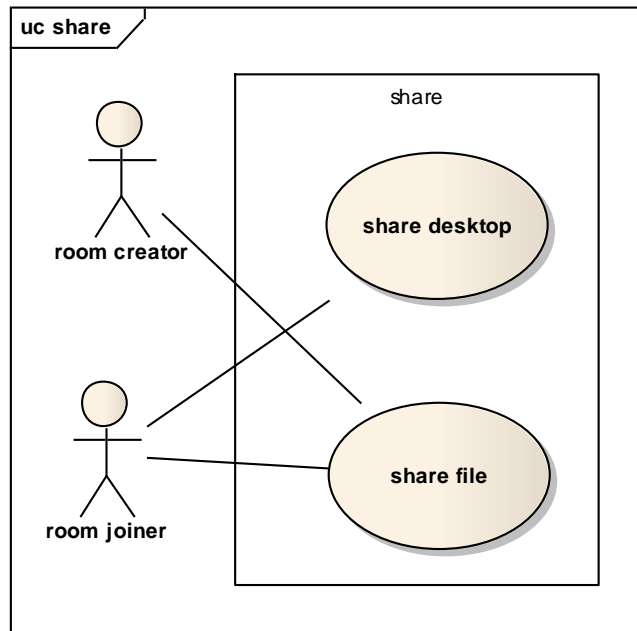

Figure 3.4 Use case diagram for share operation

### 3.6.7 Use case for call operation

The room creator and room joiners can make voice or video calls.

This illustrates in figure (3.8).

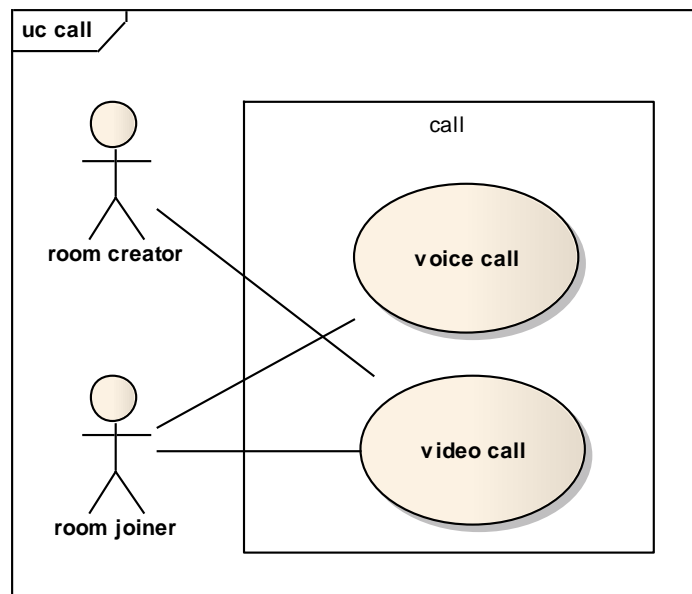

Figure 3.5 Use case diagram for call operation

## 3.6.8 Sequence diagram for add user

The admin first enters username, password and email in the system interface, when he click save data will be sent to the server then the database, the database check if this information valid to save it or not. This illustrates in figure (3.9).

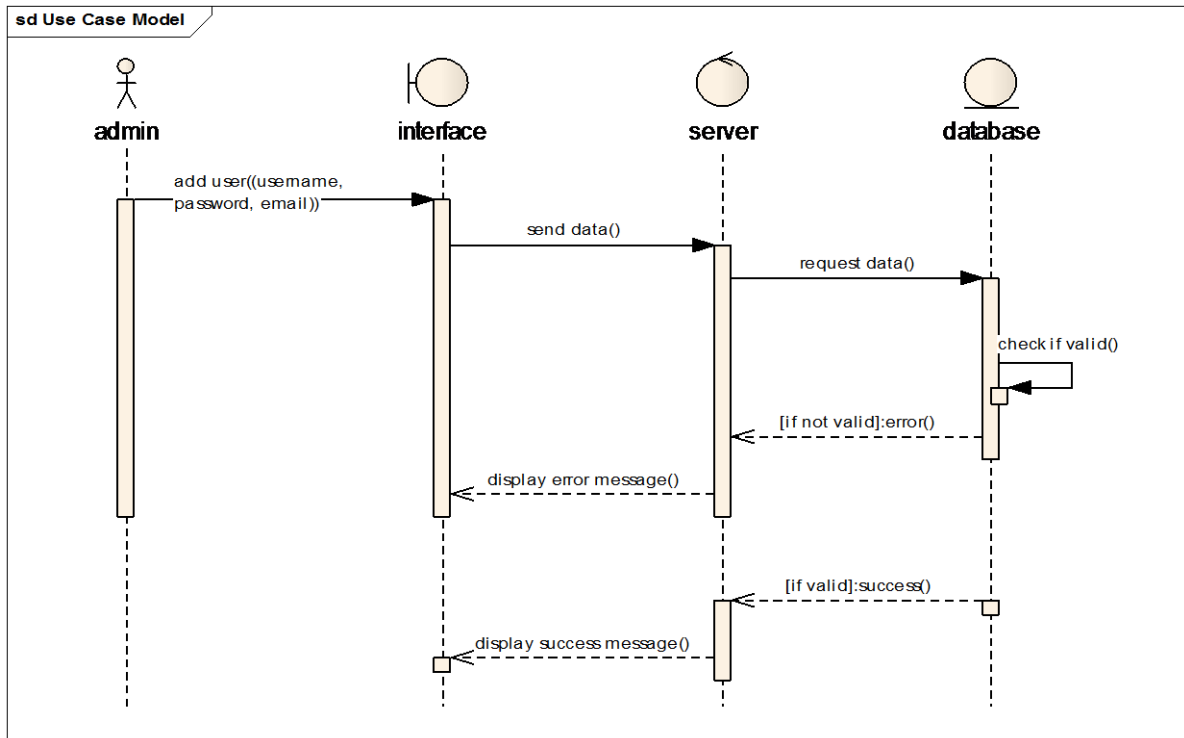

Figure 3.6 Sequence diagram for add user

## 3.6.9 Sequence diagram for register

The user first enters username, password and email in the system interface, when he clicks sign up data will be sent to the server then the database, the database check if this information valid to save it or not. This illustrates in figure (3.10).



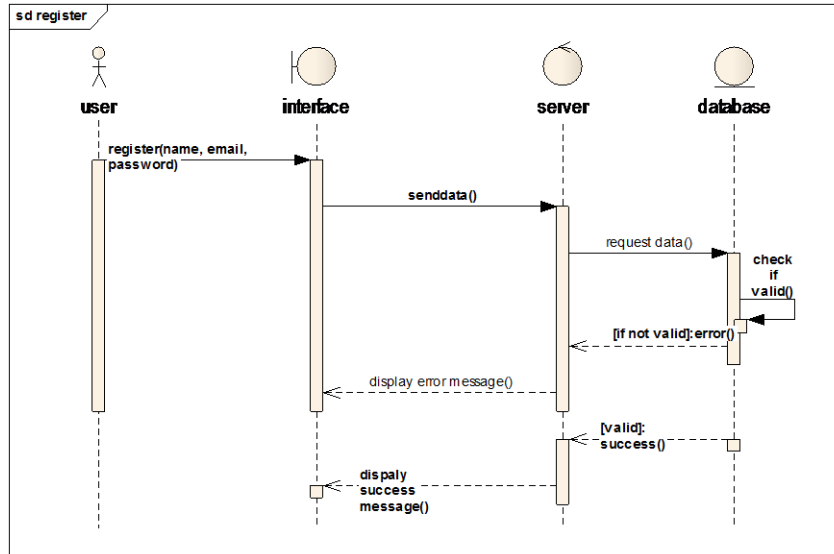

Figure 3.7 Sequence diagram for register operation

### 3.6.10 Sequence diagram for login

All users must login to use the system operations, to log in users first enter the username and password in the system interface, when they click log in data will be sent to the server then the database, the database check if this user exists to login or not. This illustrates in figure (3.11).

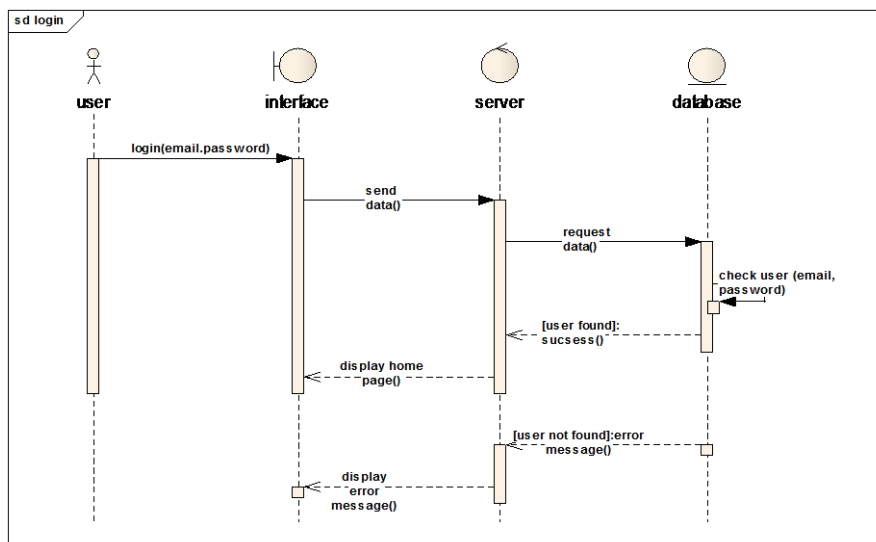

Figure 3.8 Sequence diagram for login operation

## 3.6.11 Sequence diagram for share files

Share a file in the system happened between user's interfaces, one user send file, then all other users will receive this file and they can download it. This illustrates in figure (3.12).

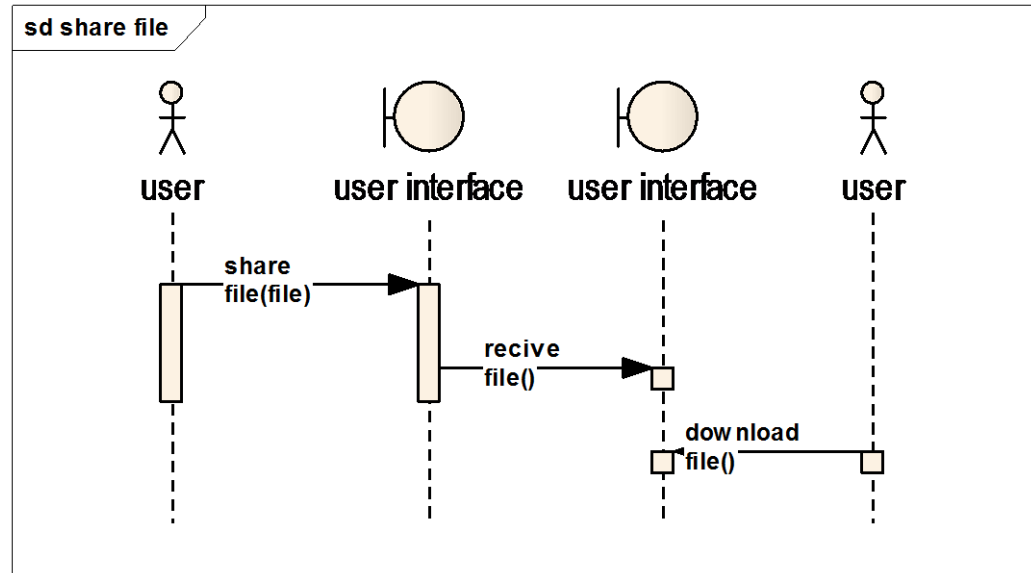

Figure 3.9 Sequence diagram for share file

## 3.6.12 Sequence diagram for share desktop

Share a desktop in the system happened between user's interfaces, one user share it's desktop, then all other users will view this desktop. This illustrates in figure (3.13).

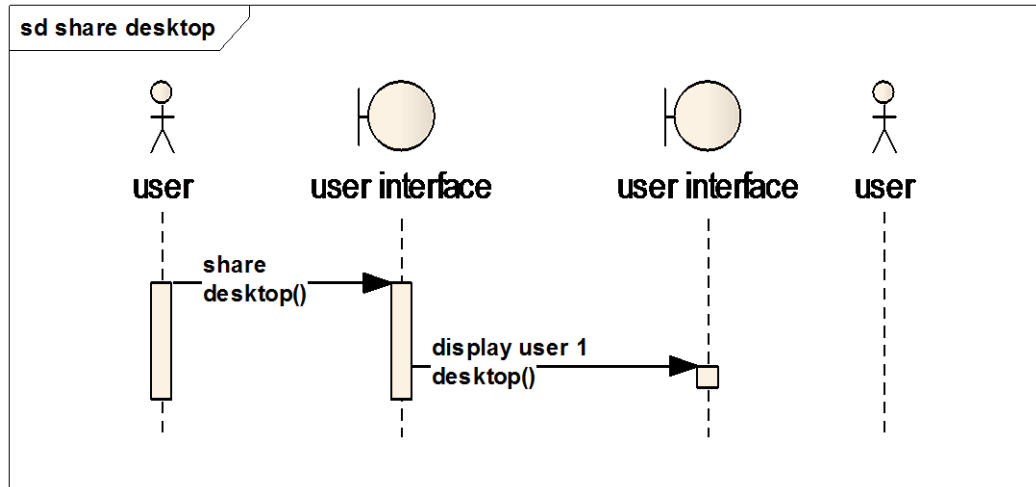

Figure 3.10 Sequence diagram for share desktop

### 3.6.13 Sequence diagram for record

The user first click record in system interface after he stop recording and click save, then data will be sent to the server and store in user local storage. This illustrates in figure (3.14).

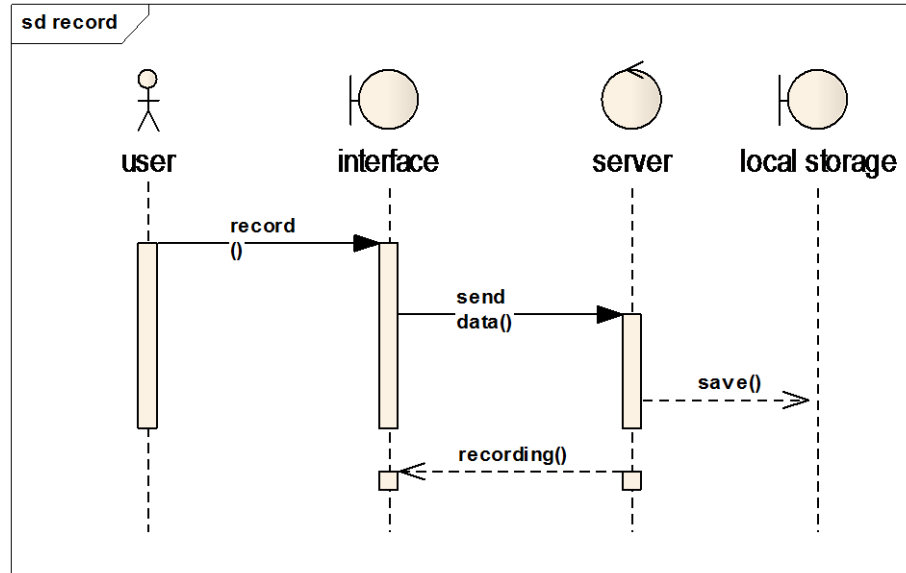

Figure 3.11 Sequence diagram for record

## 3.6.14 Sequence diagram for delete user

The admin first mark the user or users to delete in the system interface, when he clicks ok data will be sent to the server then the database, the database check if this user exists to delete it or not. This illustrates in figure (3.15).

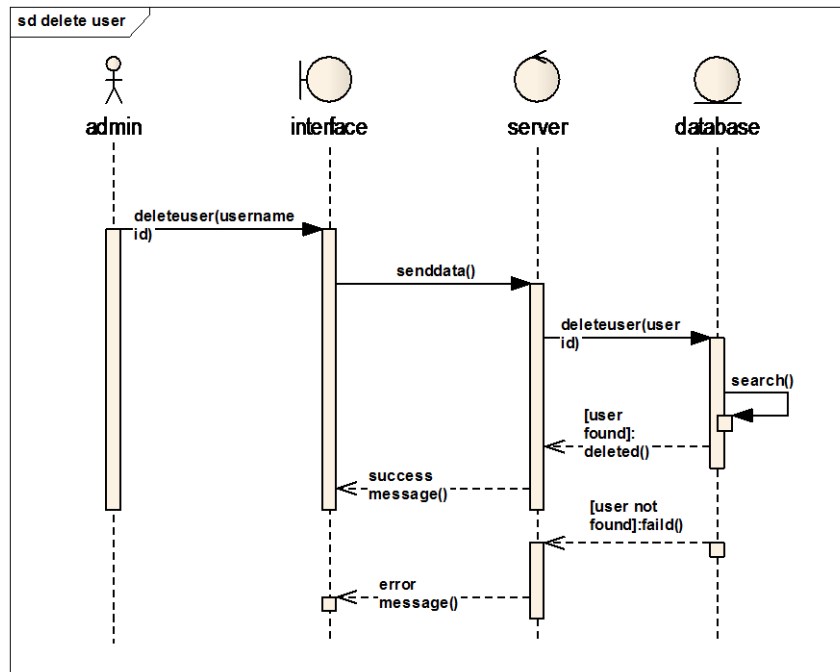

Figure 3.12 Sequence diagram for delete user

## 3.6.15 Sequence diagram for create

### room

The user enters the room id in system interface, then data will be sent to the server and then to the database, database check if this room id is unique or not to create it. This illustrates in figure (3.16).

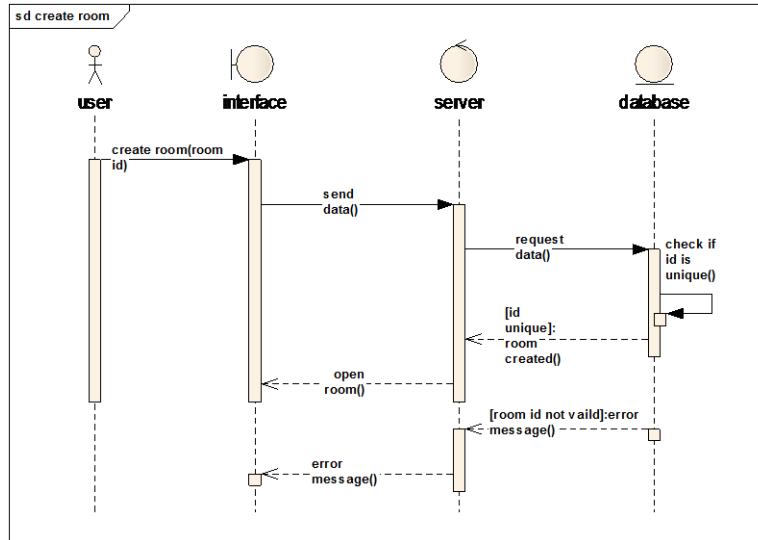

Figure 3.13 Sequence diagram for create room operation

### 3.6.16 Sequence diagram for join room

The user enter room id in system interface, then data will be send to server and then to the database, databse check if this room id is exists and opened now to join it or not. This illustrates in figure (3.17).

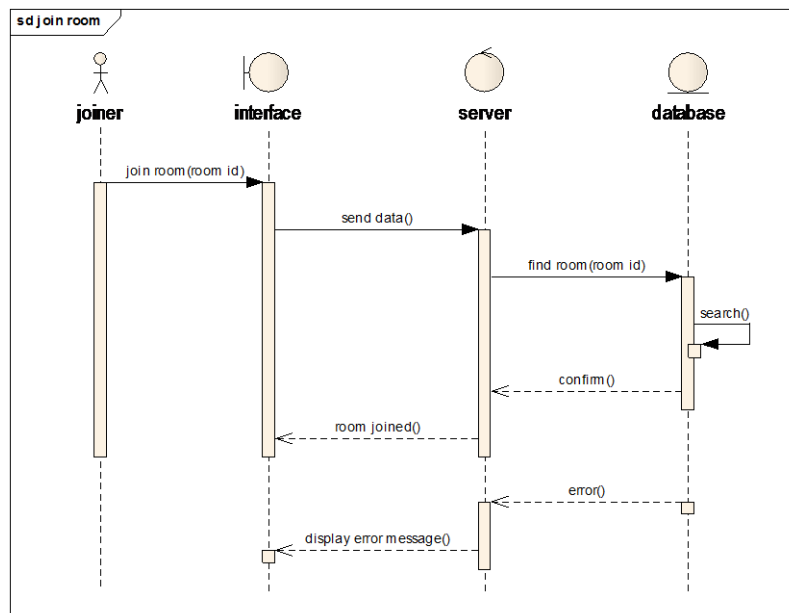

Figure 3.14 Sequence diagram for join room operation

### 3.6.17 Sequence diagram for chat

A chat in the system happened between user interfaces, one user send a message and the others replay. This illustrates in figure (3.18).

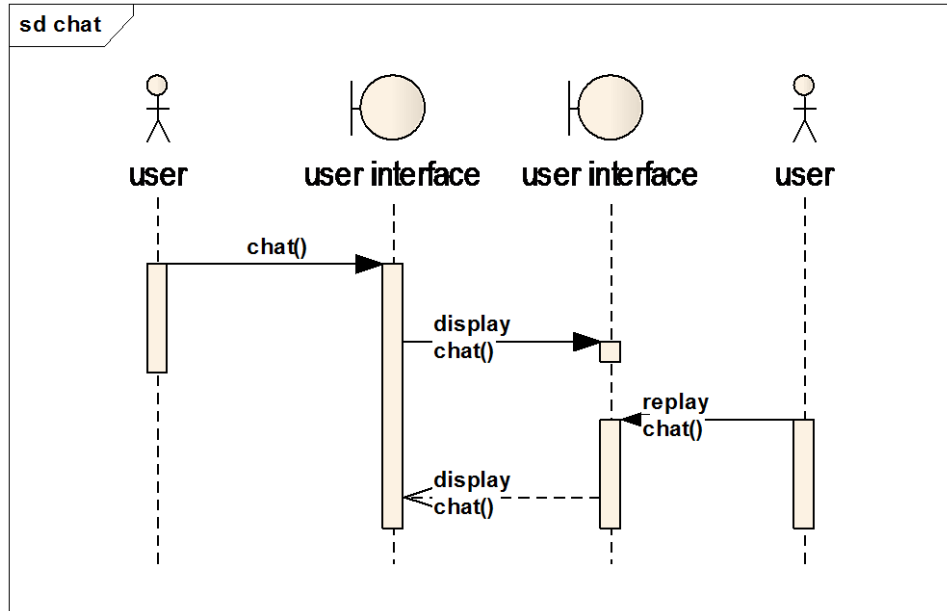

Figure 3.15 Sequence diagram for chat

### 3.6.18 Sequence diagram for call

A call in the system happened between creator and joiners interfaces, one user open room and the other users will accept this call by join this room or reject by not join. This illustrates in figure (3.19).

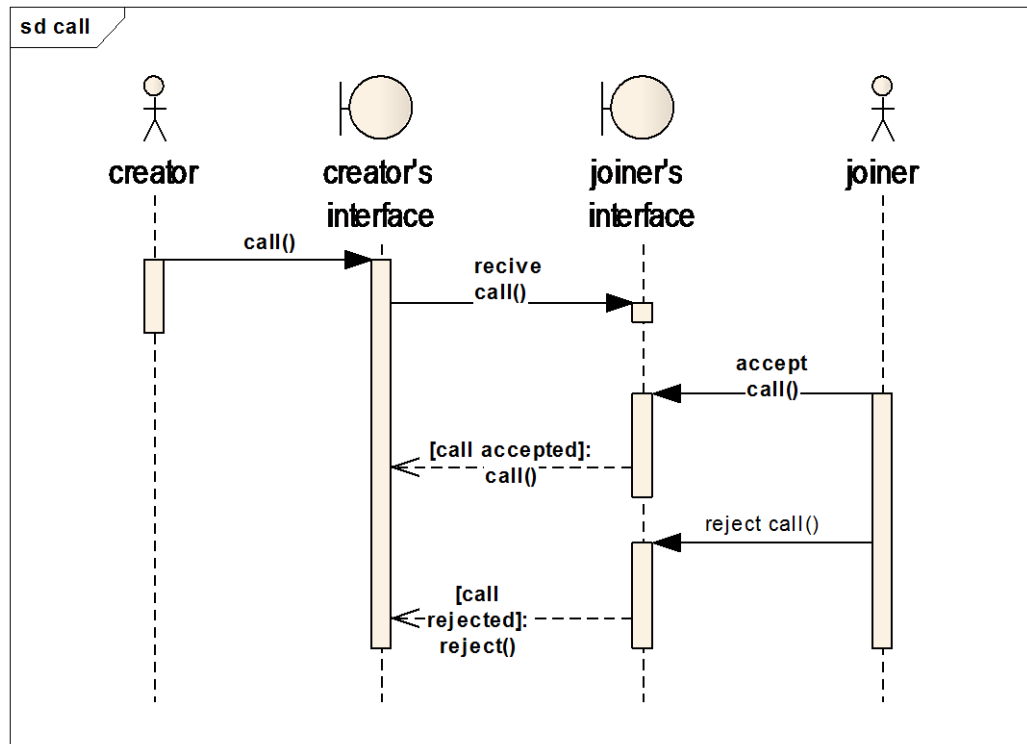

Figure 3.16 Sequence diagram for call

## 3.6.19 Sequence diagram for get attendance

The room creator click get attendance in the system interface, then data will be sent to server, then check for this room joiners in the database and return them to room creator interface. This illustrates in figure (3.20).

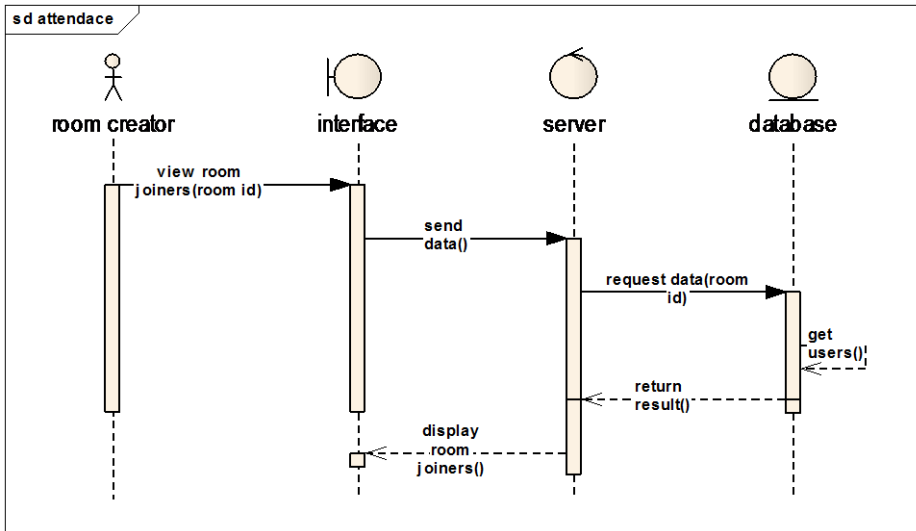

Figure 3.17 Sequence diagram for attendance

### 3.6.20 Sequence diagram for view users

The admin first enter to administrator page in the system interface, then he clicks view users then data will be displayed. This illustrate in figure (3.21).

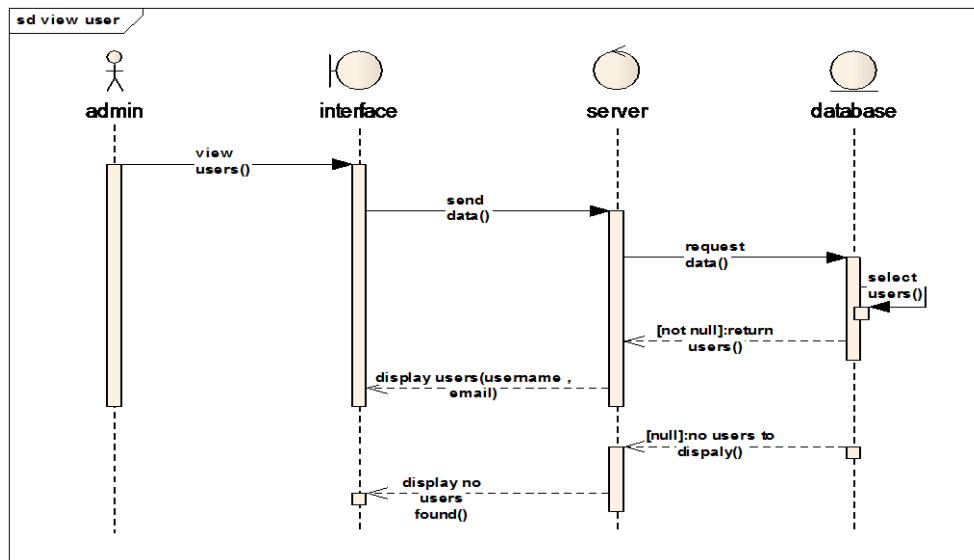

Figure 3.18 Sequence diagram for view users



### 3.6.21 Activity diagram for system

Enter URL to open the home page, in home page user can login to the system by entering its username and password to go to its page. User can create a new account by typing its valid information. This illustrates in figure (3.22).

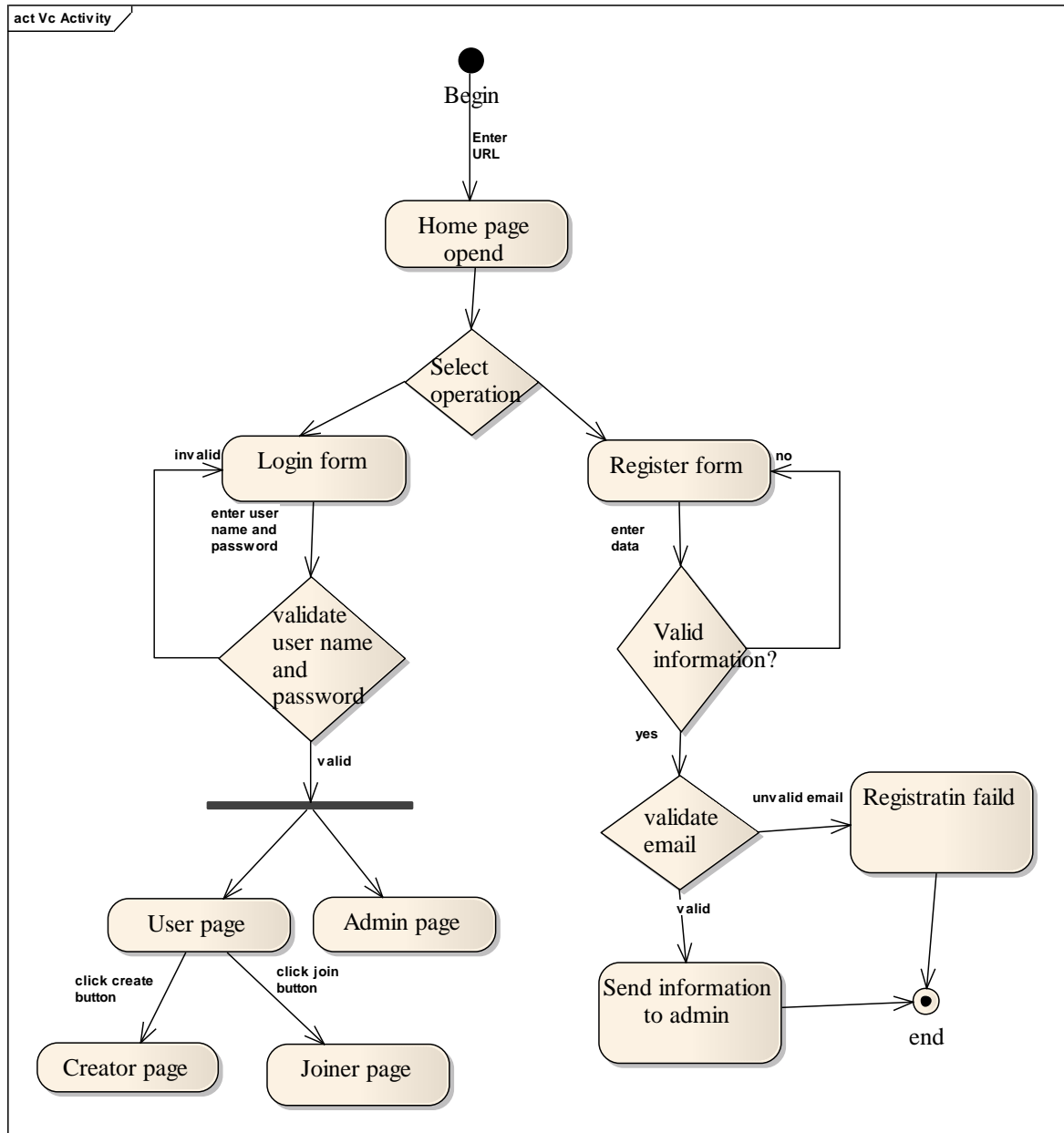

Figure 3.19 Activity diagram for system

## 3.6.22 Activity diagram for admin

In a home page if the user enters username and password of admin he go to admin page and can add, view and delete user or room. This illustrates in figure (3.23).

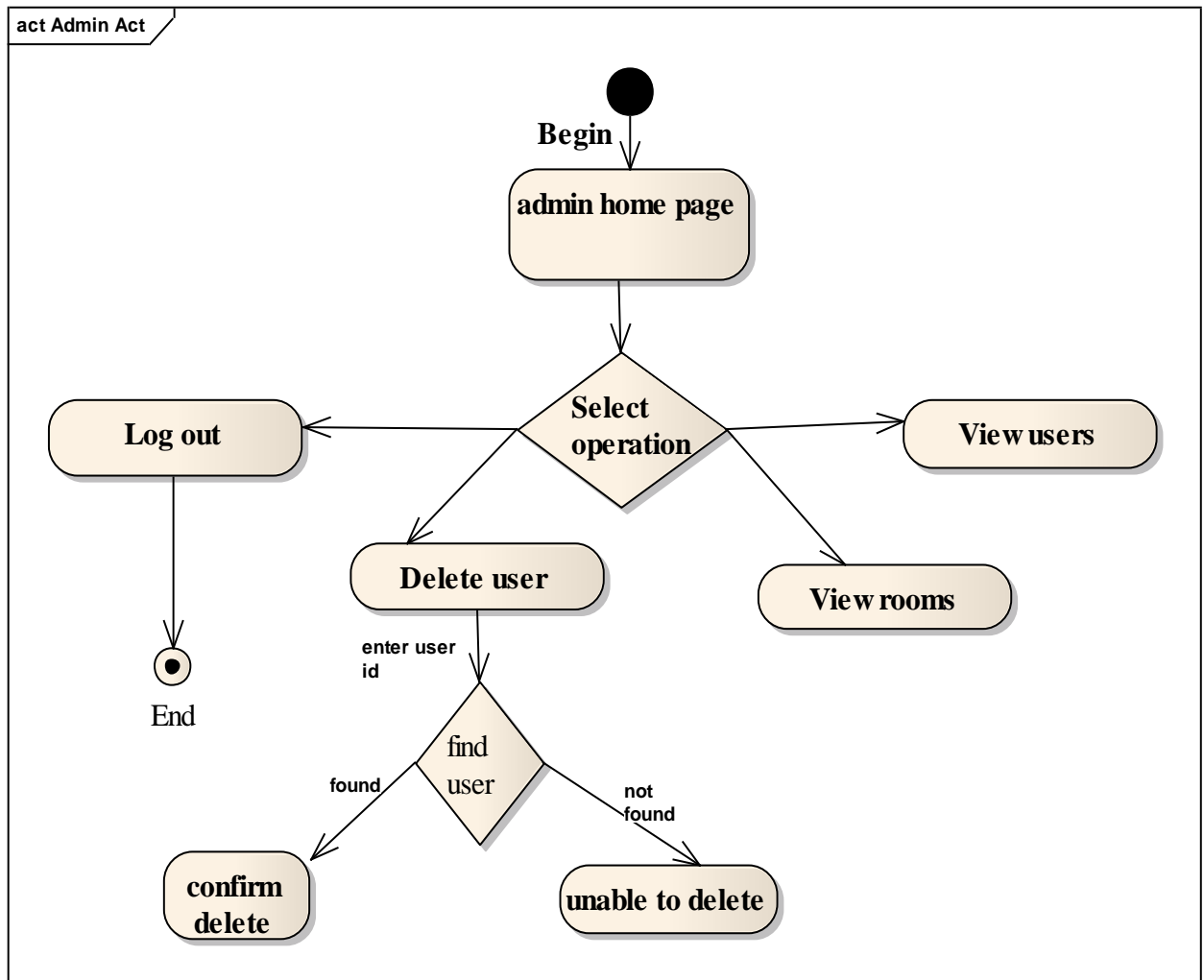

Figure 3.20 Activity diagram for admin

## 3.6.23 Activity diagram for Creator

In a home page if user enters username and password of admin he will go to a page and can create or join room.

If he clicks create button he can chat, call, share file, record, share desktop and view room joiners. This illustrates in figure (3.24).

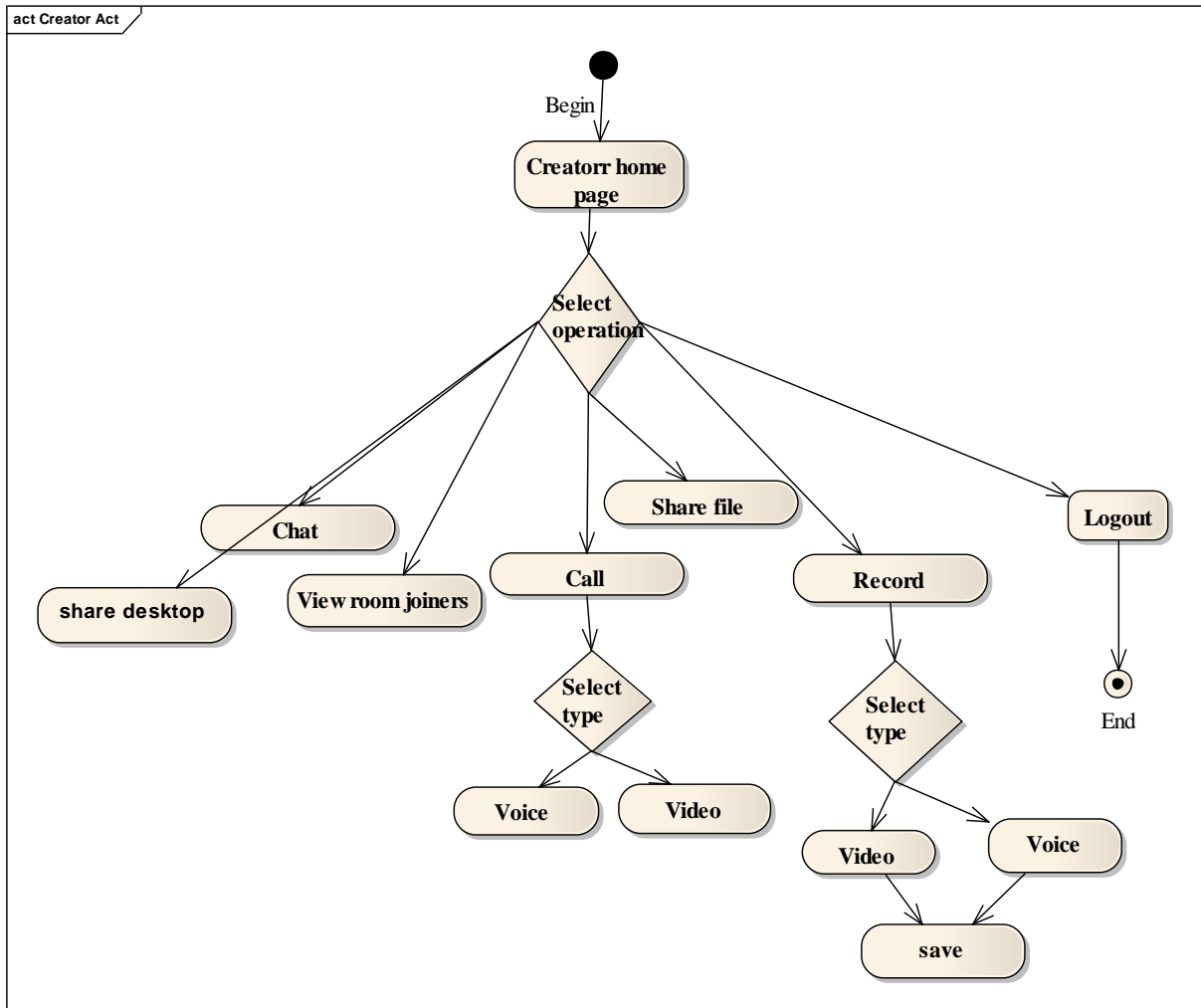

Figure 3.21 Activity diagram for creator

## 4.6.24 Activity diagram for joiner

In a home page if the user enters username and password of admin he will go to a page and can create or join room, if he click join button he can chat, call, share file, share desktop and record. This illustrates in figure (3.25).

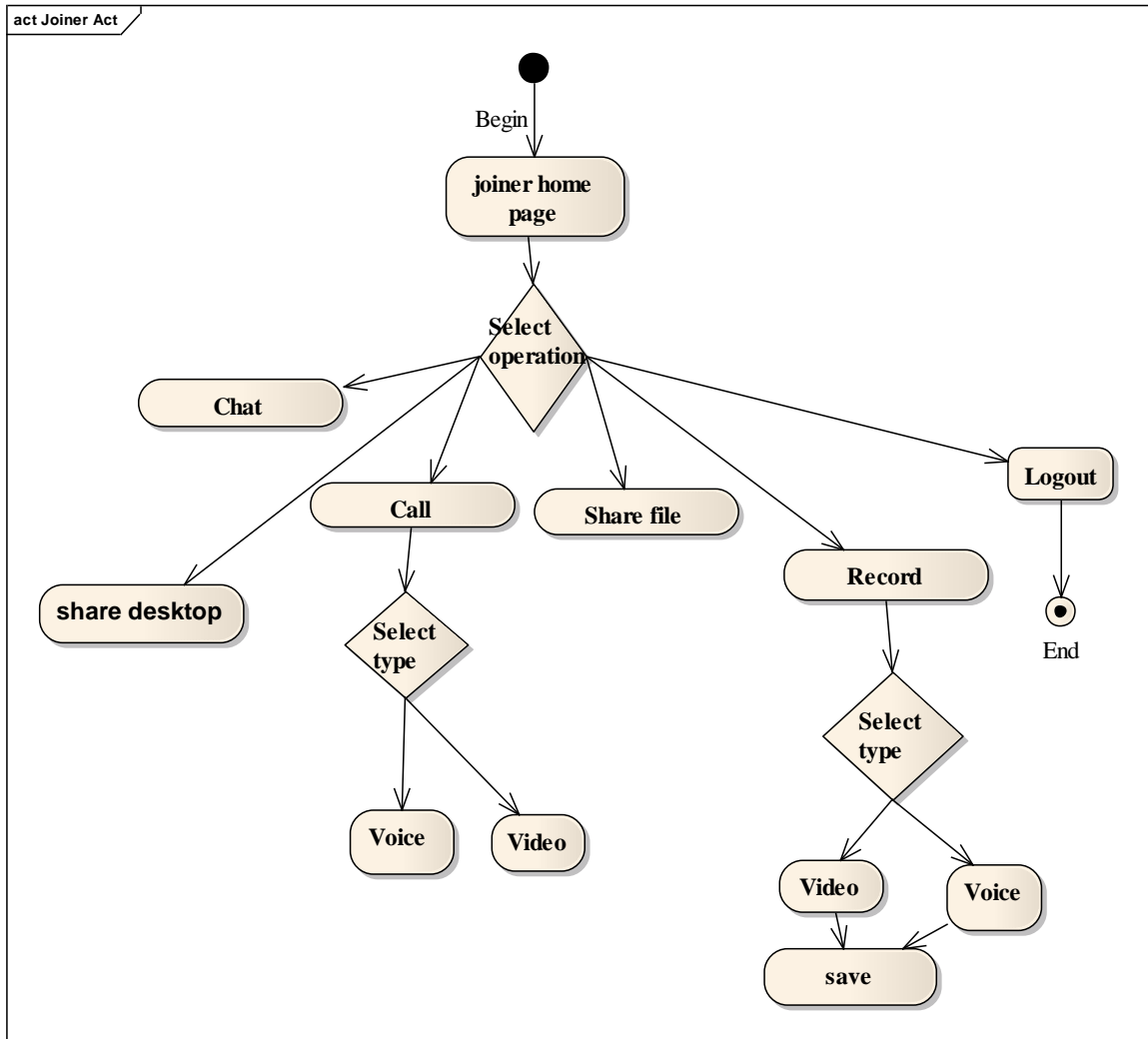

Figure 3.22 Activity diagram for joiner

## 3.7 Database Analysis

Table 4.1 Users

NO	Column name	Column name on database	Column type	Column size	Note
1	User Id	Userid	Int	10	PK
2	User Name	Uname	Char	10	-
3	Email	Email	Char	10	UNIQUE
4	Password	Password	Char	10	-

Table 4.2 Rooms

NO	Column name	Column name on database	Column type	Column size	Note
1	Room Id	roomid	Int	10	PK
2	Room Creator Id	Rcid	Int	10	FK
3	Create Time	Create time	DateTime	10	-

Table 4.3 Rooms members

NO	Column name	Column name on database	Column type	Column size	Note
1	Room Id	Roomid	Int	10	FK
2	Room Joiner Id	Rjid	Int	10	FK

## 3.8 Conclusion

This chapter dealt with a description and analysis of the system, where addressed to describe the system and processes provided by the system for the user and the system administrator, also addressed to the hardware and software components of the system. On the other hand, this section takes to analysis the operations of the system using the schemes UML and database analysis.

# **Chapter Four**

## **Implementation and Tools**

# 4.1 Introduction

This chapter shows the system administrator, user’s graphical interfaces, explains system functions and how it works and shows the techniques and tools that were used to achieve the objectives of the project.

# 4.2 Home Interfaces

This is the first page shown when the user opens the web page. User can check system features, or select the sign up button to be redirected to the sign up or login page if the user is already a member as shown in Figure (4.1).

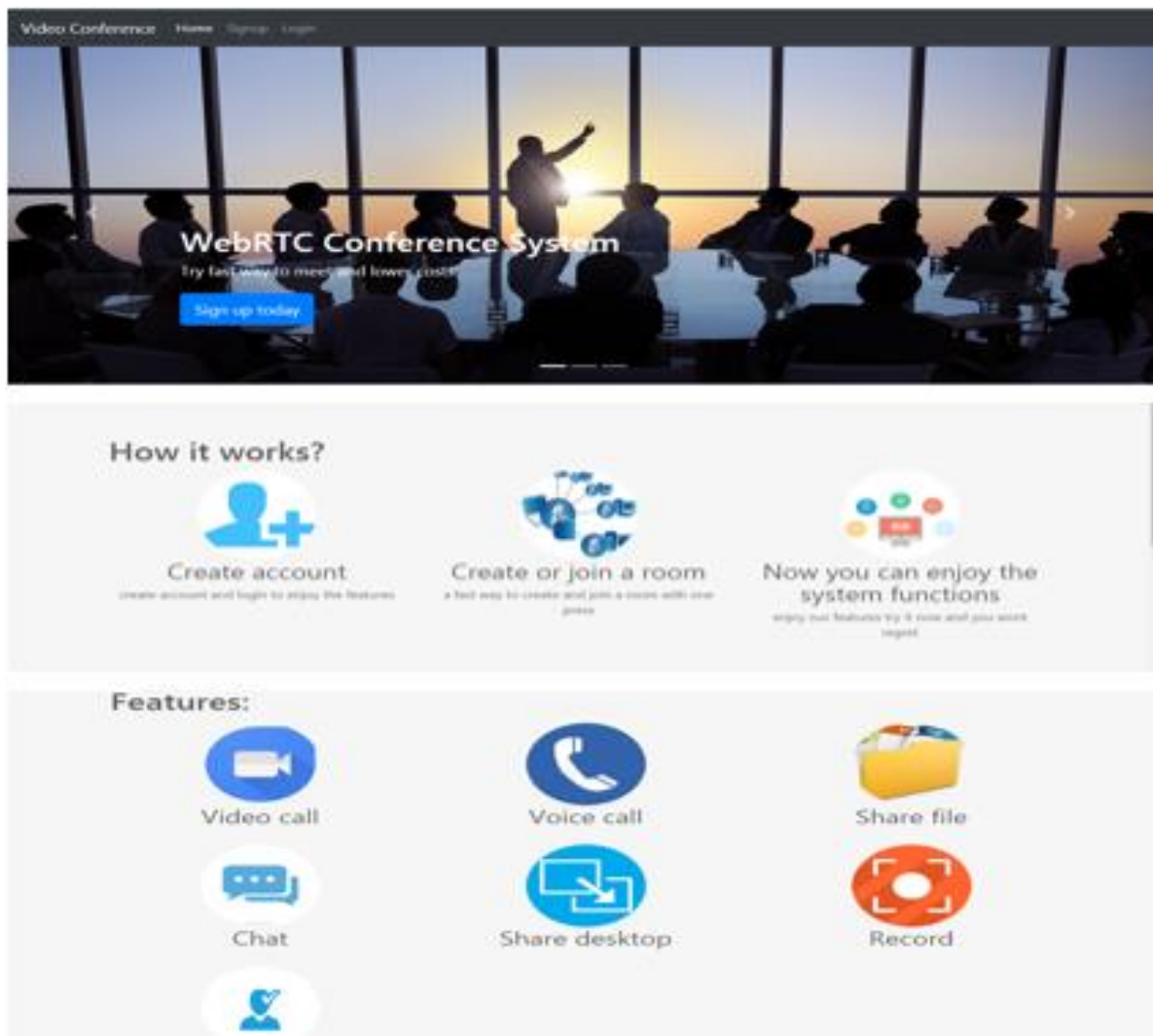

Figure 4. 1 Home interface

## 4.3 System Administrator Interface

### 4.3.1 Login

First, the system administrator must log in to the system to be able to use the system as shown in Figure (4.2).

The image shows a screenshot of the Django administration login interface. At the top, there is a dark blue header with the text "Django administration" in white. Below the header, the page is white. There are two input fields: the first is labeled "Username:" and contains the text "admin"; the second is labeled "Password:" and contains a series of dots representing a masked password. Below these fields is a blue button with the text "Log in" in white.

Figure 4.2 Administrator's login interface

### 4.3.2 Add a New User

The system administrator can add a new user by entering user's data (username, email, password) database as shown in Figure (4.3), if the data is valid it will be saved in the database as shown in Figure (4.4).

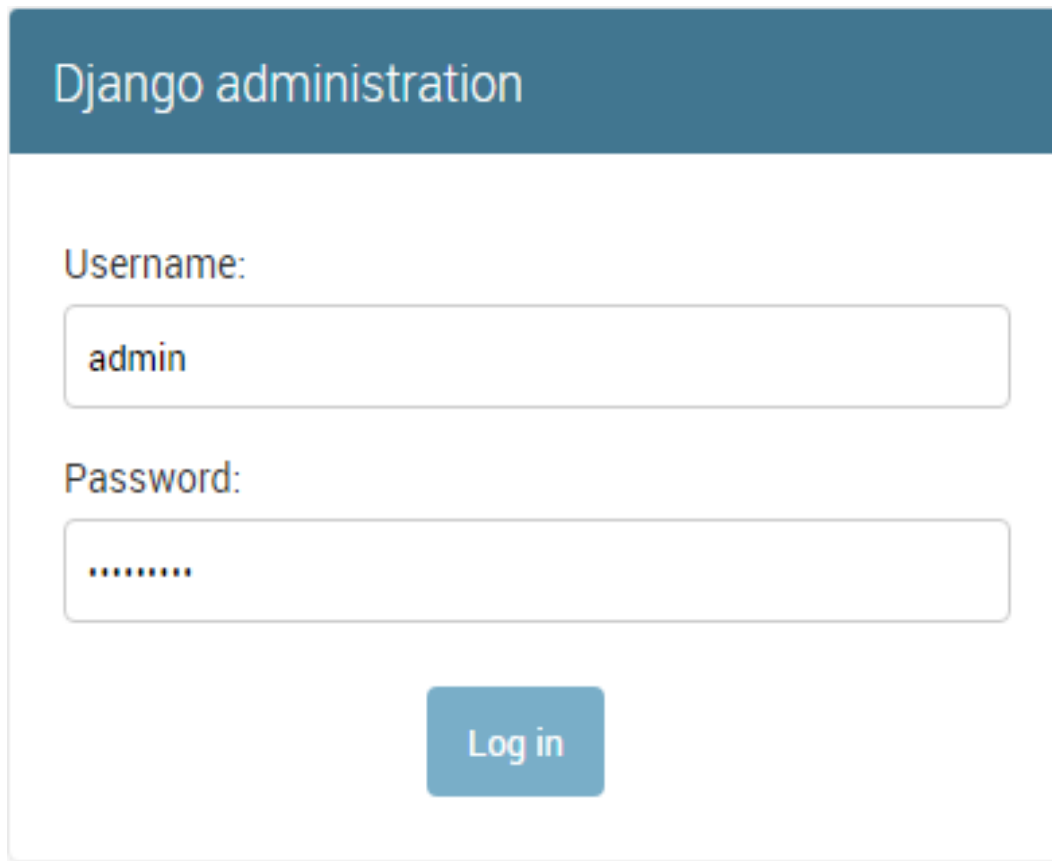

Username:   
Required. 150 characters or fewer. Letters, digits and @/./+/-/\_ only.

---

Password: `algorithm: pbkdf2_sha256 iterations: 36000 salt: VDDyCa***** hash: vDKill*****`  
Raw passwords are not stored, so there is no way to see this user's password, but you can change the password using this form.

---

**Personal info**

First name:

Last name:

Email address:

Figure 4. 3 Add new user

Select user to change

Q  Search

Action:  Go 0 of 4 selected

<input type="checkbox"/>	USERNAME	EMAIL ADDRESS	FIRST NAME	LAST NAME	STAFF STATUS
<input type="checkbox"/>	abrar	bero@gmail.com			✓
<input type="checkbox"/>	ahmedali	ahmed.ali@gmail.com	ahmed	ali	✗
<input type="checkbox"/>	alaa	alaa@gmail.com			✗
<input type="checkbox"/>	tarig	looka@gmail.com			✗

4 users

Figure 4. 4 User's database

### 4.3.3 Delete a User

The system administrator can delete user by selecting the user and pressing the go button as shown in Figure (4.4). A confirmation will appear to the admin as shown in Figure (4.6). At last, a success message will appear as shown in Figure (4.7).

Select user to change

Q  Search

Action: Delete selected users Go 1 of 4 selected

<input type="checkbox"/>	USERNAME	EMAIL ADDRESS	FIRST NAME	LAST NAME	STAFF STATUS
<input type="checkbox"/>	abrar	bero@gmail.com			✔
<input checked="" type="checkbox"/>	ahmedali	ahmed.ali@gmail.com	ahmed	ali	✘
<input type="checkbox"/>	alaa	alaa@gmail.com			✘
<input type="checkbox"/>	tarig	looka@gmail.com			✘

4 users

Figure 4. 5 Delete user

Are you sure?

Are you sure you want to delete the selected user? All of the following objects and their related items will be deleted:

**Summary**

- Users: 1

**Objects**

- User: ahmedali

Figure 4. 6 Confirm delete

✔ Successfully deleted 1 user.

Select user to change

Q  Search

Action: ----- Go 0 of 3 selected

<input type="checkbox"/>	USERNAME	EMAIL ADDRESS	FIRST NAME	LAST NAME	STAFF STATUS
<input type="checkbox"/>	abrar	bero@gmail.com			✔
<input type="checkbox"/>	alaa	alaa@gmail.com			✘
<input type="checkbox"/>	tarig	looka@gmail.com			✘

3 users

Figure 4. 7 Successful delete

## 4.4 System User Interface

### 4.4.1 Signup

A user can create a new account by entering the username, email, password and confirm password and press the signup button, if the data is valid, the user will be redirected to the login page. A login button can be used if the user already has an account as shown in Figure (4.8).

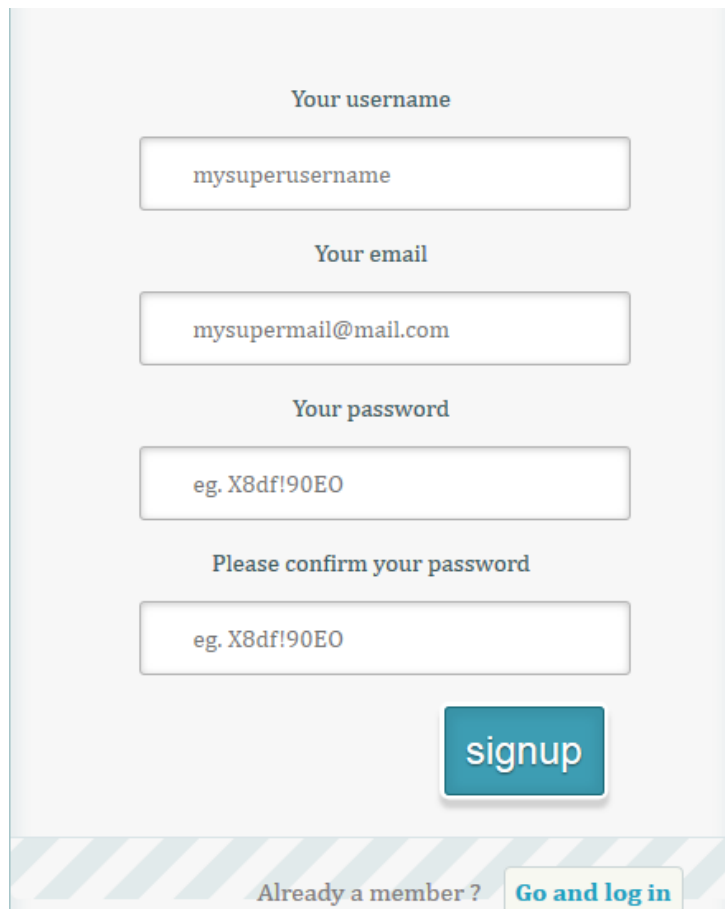

The image shows a web form for user registration. It consists of four text input fields stacked vertically, each with a label above it. The first field is labeled 'Your username' and contains the text 'mysuperusername'. The second field is labeled 'Your email' and contains 'mysupermail@mail.com'. The third field is labeled 'Your password' and contains 'eg. X8df!90EO'. The fourth field is labeled 'Please confirm your password' and also contains 'eg. X8df!90EO'. Below the fields is a blue button with the text 'signup'. At the bottom of the form, there is a link that says 'Already a member ?' followed by a button that says 'Go and log in'.

Figure 4. 8 Signup

### 4.4.2 Log in

The user enters the username and password to login to the system. If the user is not a member yet the user should sign up using the join us button to be redirected to the sign up page as shown in Figure (4.9).

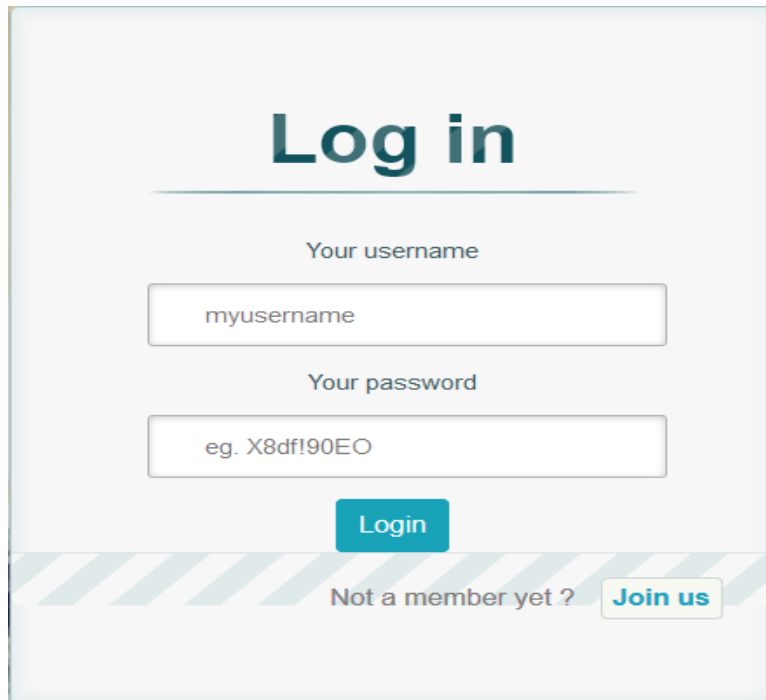

Figure 4. 9 Login

### 4.4.3 Create a Room

After logging in to the system the user will have two options (create a room or join a room). To create a room the user should enter a key if the key is not used in another room a new room will be created as shown in Figure (4.10).

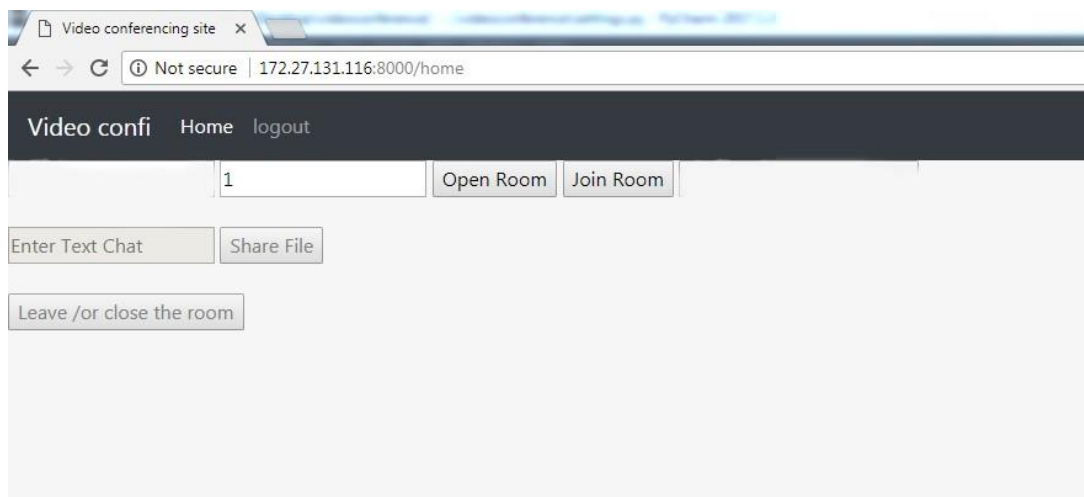

Figure 4. 10 Create room

## 4.4.4 Join a Room

The user enters a room key to join the room with that key as shown in Figure (4.11). If the room is found a permission will appear to the user to access the camera and microphone and the user can choose what to allow as shown in Figure (4.12). Figure (4.13) shows a room with 3 joiners.



Figure 4. 11 Join room

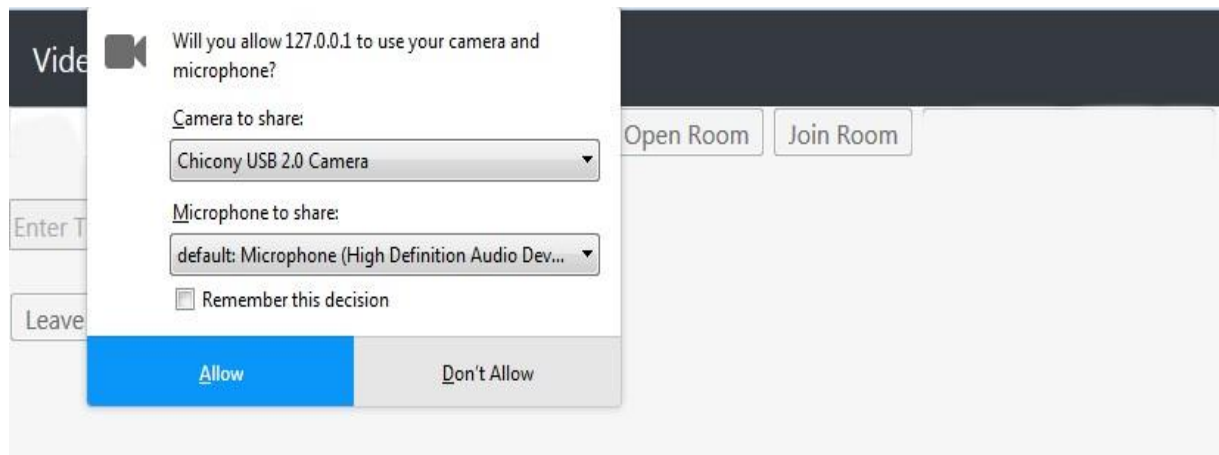

Figure 4. 12 Permissions

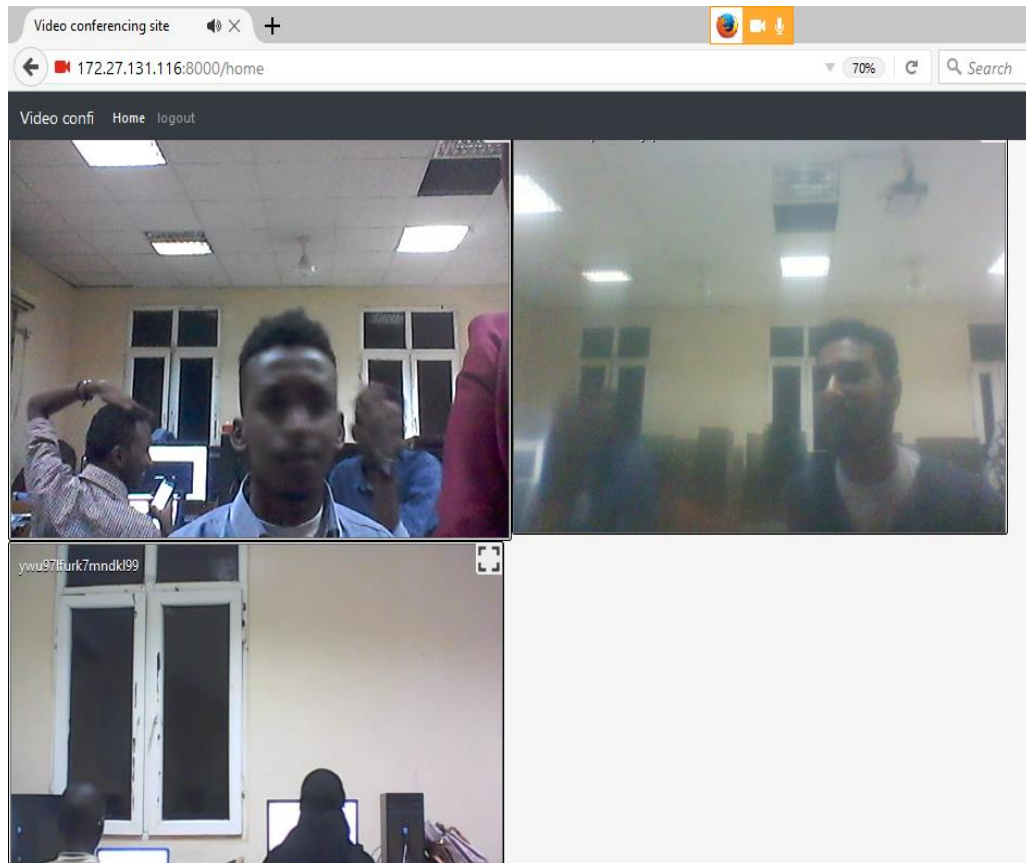

Figure 4. 13 Video and voice call

## 4.4.5 Share a File

Users at the same room can share any file from the system and it will appear to all as shown in Figure (4.14).

Users can download the shared file as shown Figure (4.14).

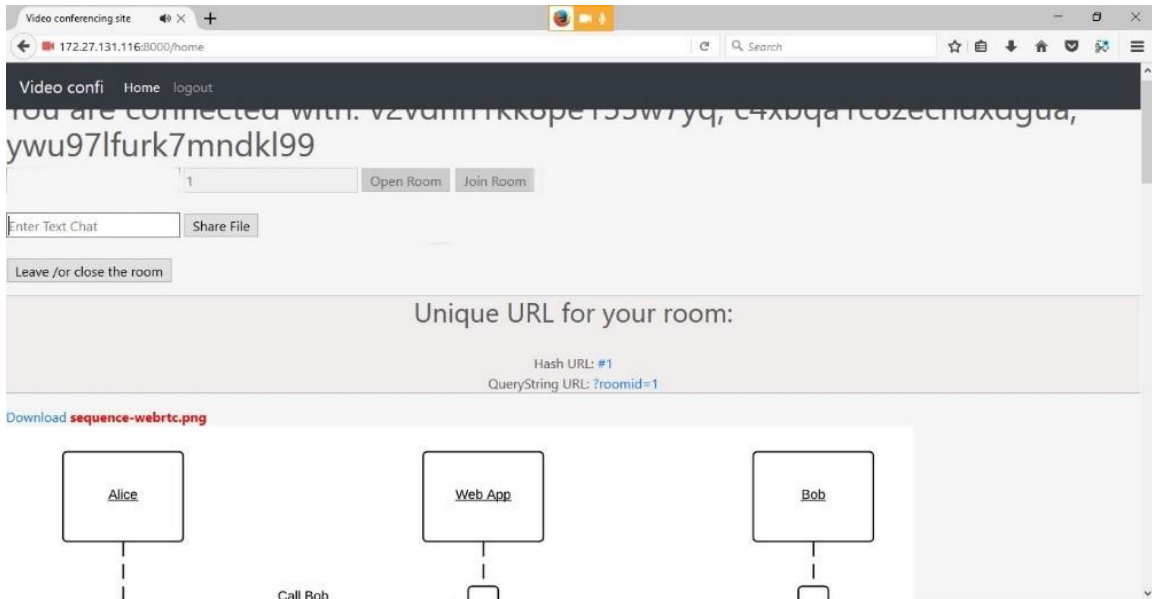

Figure 4. 14 Share file

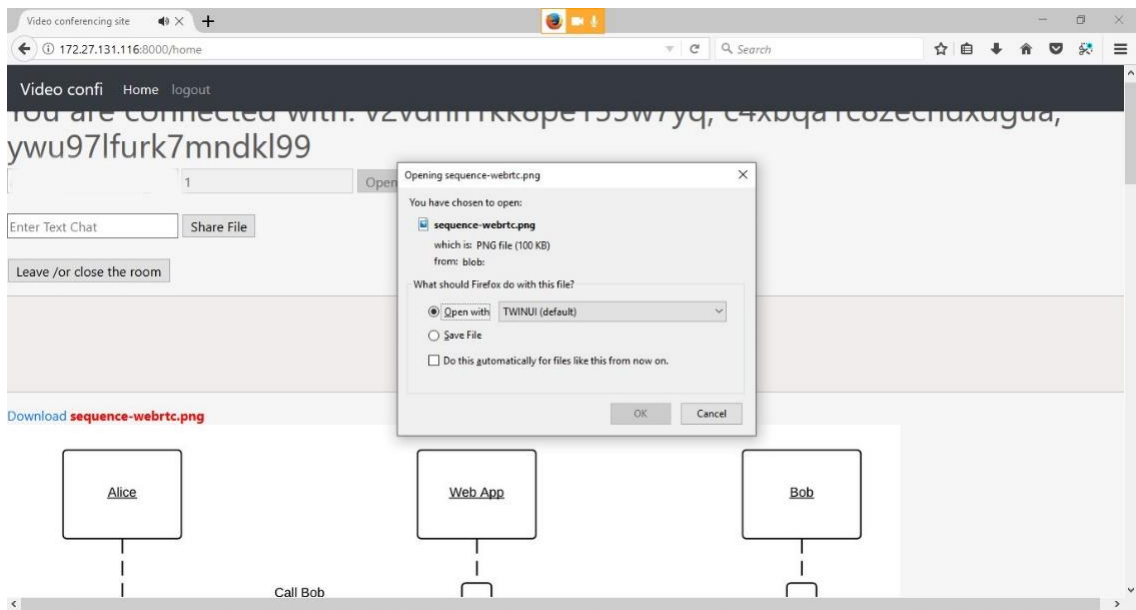

Figure 4. 15 Download shared file

## 4.4.6 Chat

After joining a room, a user can chat with the room members as shown in Figure (4.16).

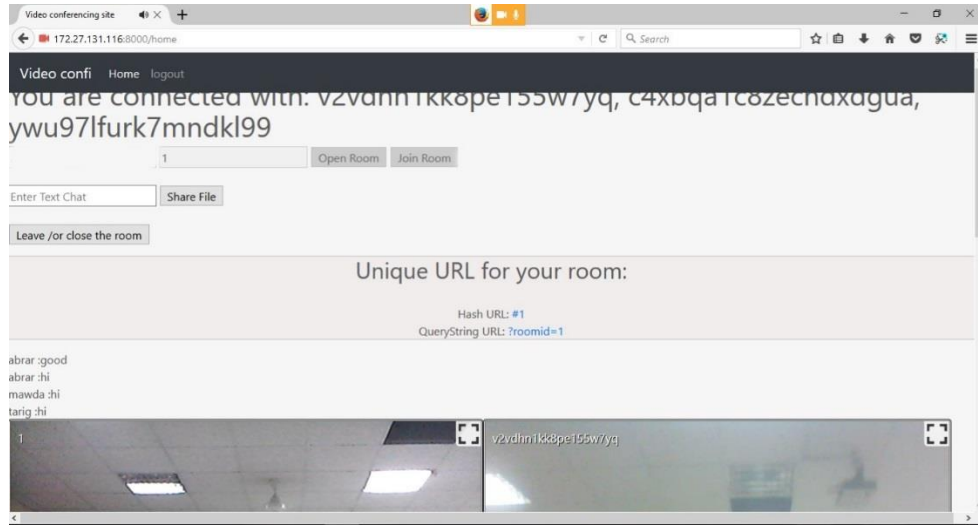

Figure 4. 16 Chat

## 4.4.7 Share a Desktop

The user can share his desktop with other users at the same room as shown in Figure (4.18). A permission will be shown to the user before sharing desktop as shown in Figure (4.17).

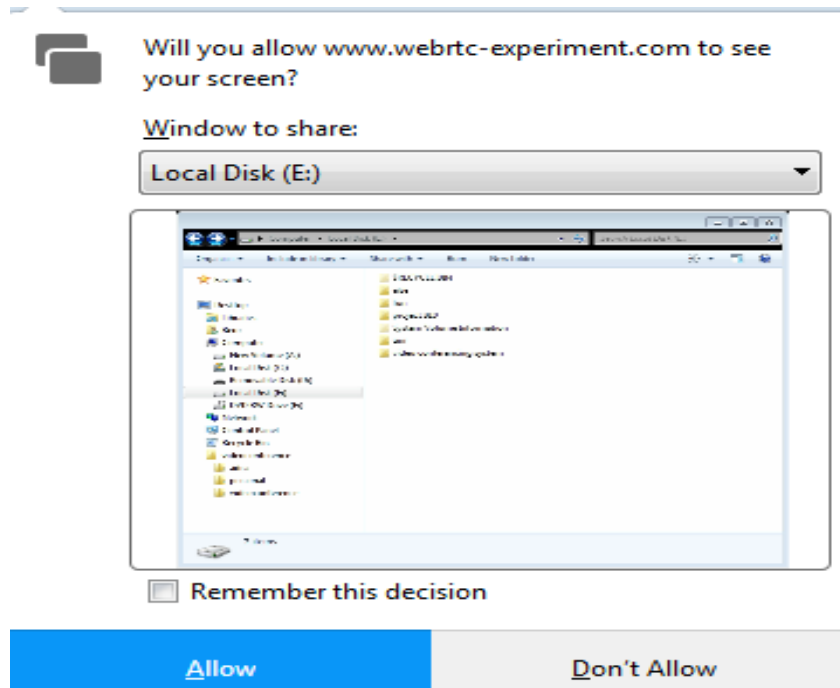

Figure 4. 17 Share desktop permission



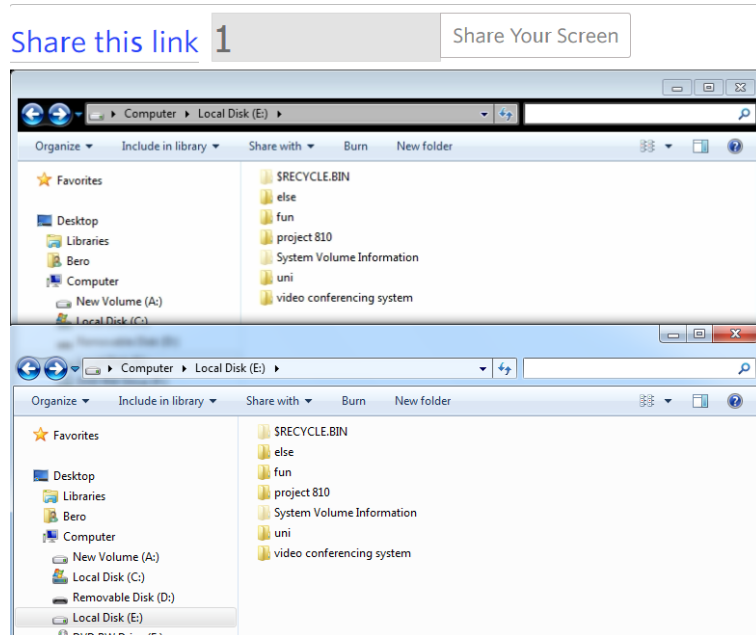

Figure 4. 18 share desktop

## 4.4.8 Voice Record

The system users can record the session. A microphone only access will be given and after ending recording the user can choose where to save the record as shown in Figure (4.19).

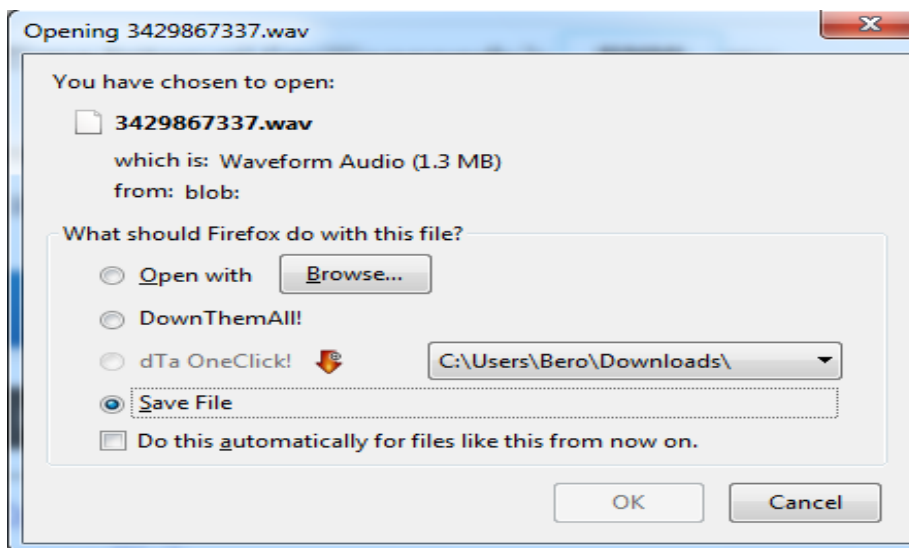

Figure 4. 19 Voice record

## 4.4.9 Video Record

The system users after joining room can record session in video after ending the record user can choose where to save the record as shown in Figure (4.20).

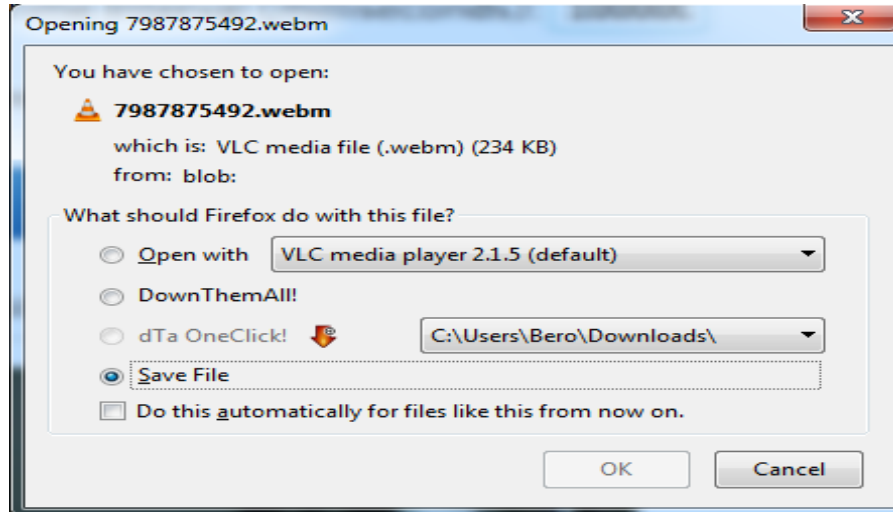

Figure 4. 20 Video record

## 4.5 Tools and Techniques

To develop this video conference system many techniques were used such as UML, python, Django, WebRTC, SQLite, and bootstrap.

### 4.5.1 UML (Unified Modeling Language)

UML stands for “Unified Modeling Language”. It is an industry-standard graphical language for specifying, visualizing, constructing and documenting the artifacts of an object-oriented system under development. It provides many models. In this project, we use the following:

- **Use case Model:** captures the requirements of a system. Use cases are a means of communication among users and other stakeholders what the system is intended to do [13].
- **Sequence Model:** is a form of interaction diagram which shows objects as lifelines running down the page. Their interactions over time are represented

as messages drawn as arrows from the source lifeline to the target lifeline [13].

- **Activity diagram:** describes dynamic aspects of the system. Activity diagram is a flow chart to represent the flow from one activity to another activity. The activity can be described as an operation of the system [13].

## 4.5.2 Python

Python is an interpreter, object-oriented, high-level programming language with dynamic semantics. Its high-level built-in data structures, combined with dynamic typing and dynamic binding, as well as for use as a scripting or glue language to connect existing components together.

### 4.5.2.1 Python Advantages

The following are some of the main advantages of Python:

- **Presence of Third Party Modules:** The Python Package Index (PyPI) contains numerous third-party modules that make Python capable of interacting with most of the other languages and platforms.
- **Extensive Support Libraries:** Python provides a large standard library. Many high-use programming tasks have already been scripted into the standard library, which reduces the length of code to be written significantly.
- **Open Source and Community Development:** Python language is developed under an OSI-approved open source license, which makes it free to use and distribute, including for commercial purposes.
- **Learning Ease and Support Available:** Python offers excellent readability and uncluttered simple-to-learn syntax.
- **User-friendly Data Structures:** Python provides the option of dynamic high-level data typing, which reduces the length of support code that is needed.

- **Productivity and Speed:** Python has clean object-oriented design and possesses strong integration and text processing capabilities and its own unit testing framework, all of which contribute to the increase in its speed and productivity.
- **Integration Feature:** Python integrates the Enterprise Application Integration that makes it easy to develop Web services by invoking COM or COBRA components.

## 4.5.3 Django

Django is a free and open source web application framework written in Python. It also offers a big collection of modules which you can use in your own projects. Primarily, frameworks exist to save developers a lot of wasted time and headaches [14].

### 4.5.3.1 Django advantages

The following are some of main advantages of django:

- Fast
- Fully Loaded
- Secure
- Scalable
- Versatile

## 4.5.4 WebRTC

WebRTC (web real time communication) is collection of communications protocols and application programming interfaces that enable real time communication over peer-to-peer connections, It gives us rich and high-quality video streaming via JavaScript APIs [1] [2].

#### **4.5.4.1 WebRTC Advantages**

With today's economy, it is even more important for business to embrace WebRTC as part of their initiative to reduce costs and remain effective and competitive. WebRTC APIs is supported by most leading Browsers for Windows (Google Chrome, Firefox and Opera) [3].

- WebRTC is an open-source application programming interface (API).
- WebRTC enabled browser with any operating system and a web services application can direct the browser to create a real-time voice or video connection to another WebRTC device or to a WebRTC media server.
- Always on voice and video encryption. The Secure Real-time Transport protocol (SRTP) is used for encryption and authentication of both voice and video.
- WebRTC give advanced voice and video quality.
- WebRTC supports reliable session establishment.
- WebRTC supports the negotiation of multiple media types and endpoints.

#### **4.5.5 SQLite**

In the simplest terms, SQLite is a public-domain software package that provides a relational database management system, or RDBMS. Relational database systems are used to store user-defined records in large tables. In addition to data storage and management [15].

SQLite is an amazing library that gets embedded inside the application that makes use of. As a self-contained, file-based database, SQLite offers an amazing set of tools to handle all sorts of data with much less constraint and ease compared to hosted, process based (server) relational databases [15].

### 4.5.5.1 SQLite Advantages

The following are some of SQLite advantages [16]:

- **File based:** The entire database consists of a single file on the disk, which makes it extremely portable.
- **Standards-aware:** Although it might appear like a "simple" DB implementation, SQLite uses SQL. It has some features omitted (RIGHT OUTER JOIN or FOR EACH STATEMENT), however, some additional ones are baked in.
- **Great for developing and even testing:** During the development phase of most applications, for many people it is extremely likely to need a solution that can scale for concurrency. SQLite, with its rich feature base, can offer more than what is needed for development with the simplicity of working with a single file and a linked C based library.

## 4.5.6 Bootstrap

Bootstrap is an open source toolkit for developing with HTML, CSS, and JS. Quickly prototype your ideas or build your entire app with responsive grid system, extensive prebuilt components, and powerful plugins built on jQuery [17].

## 4.6 Conclusion

This chapter shows the administrator and user interfaces and how the system functions works and the tools and techniques that were used to achieve the project objectives.

**Chapter Five**

**Results, Conclusion and**

**Recommendations**

## 5.1 Introduction

This chapter transact with the research after conducting many tests on the system, recommendations for future research and conclusion.

## 5.2 Results

After completing the video conference system the following results has been achieved:

- Web-based video conference system was developed.
- User can create or join a room.
- Users can make voice or video calls.
- Users in the same room can chat or share desktop with each other.
- Users can save their meetings by recording them.
- User who creates the session can know how attend and save that attendance.
- The system reduces physical effort by using this video conference system instead of a real meeting.
- Ease of communicating and sharing files.
- Use the system from any place or time.

## 5.3 Conclusion

A video conferencing system using WebRTC technology was created and approved.

In this research we used the WebRTC technology for its ease of use and does not need any plugins or application to install it just need browser that it support.

The video conference system is designed as web-based to be used from different operating systems.

The aim of this research is to reduce the effort and difficulty of mobility to communicate and to create a video conference that supports the characteristics of voice calls, video calls, share files, share desktop, record in different format and attendance for who attend. These goals have been achieved.



The system is not perfect, perfection is not something humans can accomplish but we as developers did our best to provide all the features we need to ease communication, health care, education and all other fields meeting in our country.

## **5.4 Recommendations**

After the completion of this project and applied it, we recommend the following to improve the system:

- Integrate the system with cloud storage.
- Integrate the system with billing system.
- Integrate the system with social media.
- Invite unregistered user to join room.

# References



- [1] "WebRTC"[Online]. Available: <http://dev.w3.org/webrtc/>. [Accessed 3 5 2017].
- [2] "WebRTC"[Online]. Available: <https://www.webrtc.org/definition/WebRTC..> [Accessed 3 5 2017].
- [3] D. Ristic, "learning WebRTC," 2017.
- [4] "Videolink 2me," [Online]. Available: [www.videolink2.me..](http://www.videolink2.me..) [Accessed 29 4 2017].
- [5] "veeting rooms"[Online]. Available: [www.veeting.com..](http://www.veeting.com..) [Accessed 29 4 2017].
- [6] "q audio," [Online]. Available: [www.qconf.com..](http://www.qconf.com..) [Accessed 29 4 2017].
- [7] "cisco webex," [Online]. Available: <httpsreviews.financesonline.compcisco-webex>. [Accessed 10 10 2017].
- [8] "click meeting," [Online]. Available: <httpsreviews.financesonline.clickmeeting>. [Accessed 10 10 2017].
- [9] "financesonline," [Online]. Available: <httpsreviews.financesonline.ringcentral>. [Accessed 10 10 2017].
- [10] D. D. M. T. Y. C.-M. Arin Sime, WebRTC Video and Telehealth, april 2017.
- [11] S. O. G. M. I. N. C. S. A. B. MBACKE, WebRTC platform proposition as a support to educational system of universities in a limited internet connection context, IEEE, 2015.
- [12] "pcmag," [Online]. Available: [/www.pcmag.com/article2/0,2817,2388678,00.asp..](http://www.pcmag.com/article2/0,2817,2388678,00.asp..) [Accessed 13 3 2017].
- [13] " Unified Modeling Language "[Online]. Available: <http://searchsoftwarequality.techtarget.com/definition/Unified-Modeling-Language>. [Accessed 7 8 2017].
- [14] " Django web framework "[Online]. Available: [https://WWW.Django\\_%28web\\_framework%29..](https://WWW.Django_%28web_framework%29..) [Accessed 22 8 2017].
- [15] "sqlite "[Online]. Available: <https://www.safaribooksonline.com/library/view/sqlite>. [Accessed 7 8 2017].

- [16] "sqlite " [Online]. Available: <https://www.sqlite/9781449394592/ch01>. [Accessed 7 8 2017].
- [17] "bootstrap"[Online]. Available: <http://getbootstrap.com/>. [Accessed 9 8 2017].
- [18] "why use uml "[Online]. Available: <http://dthomas-software.co.uk/resources/frequently-asked-questions/why-use-uml-2/>. [Accessed 7 8 2017].
- [19] "bootstrap" [Online]. Available: <https://bootstrapbay.com/blog/reasons-to-use-bootstrap/>. [Accessed 9 8 2017].



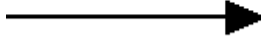
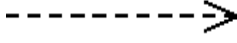

# **Appendices**

Appendix (I) explain the symbols used in the modeling and analysis system using UML diagrams:



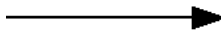
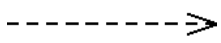

Explain the symbols used in (Use case Diagram)

 Actor			 use case
User	connect	Connect task that depends on other	task

Explain the symbols used in (Sequence Diagram)

 Actor	 Interface			 Server	 Database
User	User GUI	UML message	message Response	Program logic	database

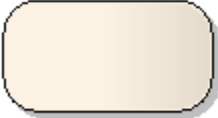
Explain the symbols used in (Activity Diagram)

				
Begin	End	Decision	Activity	Connect