

CHAPTER ONE

Introduction

1.1. Introduction

The word laser is an acronym for light amplification by stimulated emission of radiation. The laser is five decades old, but its roots go back long before physicists had developed the theoretical concepts behind the laser or its microwave-emitting counterpart, the maser. The thread of ideas leading to the laser can be traced back to a theory of light emission proposed by Albert Einstein during World War I [1].

The beam of light generated by a typical laser can have many properties that are unique. Lasers generally have a narrower frequency distribution "monochromatic", or much higher intensity, or much greater degree of collimation "directionality", or much shorter pulse duration "coherence".

Lasers have found a host of important applications in fields ranging from medicine and research on atomic physics to home entertainment, fiber-optic communications, and military systems. Lasers help preserve vision, weld state-of-the-art razor blades, read product labels at supermarkets, and play music from compact discs [1].

The helium-neon laser was one of the first lasers ever developed and is still one of the most widely used lasers. They operate in a low-pressure mixture of helium and neon gases, and the laser transitions occur within the neutral atomic species. The most common wavelength is the 632.8 nm transition in the red portion of the spectrum [2].

Glass is a non-crystalline amorphous solid that is often transparent and has widespread practical, technological, and decorative usage in, for example, window panes, tableware, and optoelectronics. The most familiar, and historically the oldest, types of glass are "silicate glasses" based on the chemical compound silica (silicon dioxide, or quartz), the primary constituent of sand. Of the many silica-based glasses that exist, ordinary glazing and container glass is formed from a specific type called soda-lime glass, composed of approximately 75% silicon dioxide (SiO_2), sodium oxide (Na_2O) from sodium carbonate (Na_2CO_3), calcium oxide, also called lime (CaO), and several minor additives [3].

Nonlinear optics (NLO) is the study of all the phenomena that occur from the interaction of intense light with matter [4,5]. The interaction with a nonlinear optical material causes a modification of the optical properties of the system, and the next photon that arrives sees a different material. Typically only laser light is sufficiently intense to generate NLO phenomena; therefore the beginning of this research field is often taken to be the discovery of second-harmonic generation by Franken et al. in 1961 [6], the year after the construction of the first laser by Maiman [7]. The principle of superposition is violated in a nonlinear optical medium [8].

1.2. Problem of the Research

The problem of this work is that, there was no previous experimental studies about the field of nonlinear optics to study the changes in the optical properties of materials, in order to achieve best results, where its introduced in many applications such as optical wave manipulation, which is one of the future technologies for optical processing. And also it has various applications in fiber-optic communications and optoelectronics, which makes it an increasingly important topic among electrical engineers.

1.3. Aims of the Research

The aims of this research are to investigate the effect of heat on the optical properties of glass, and to study whether ordinary glass shows any non-linear behavior by heating or not.

1.4. Research Methodology

A He-Ne Laser will be applied to the glass sample (soda-lime glass), then a heat source will be applied perpendicular to the glass, and the results will be obtained.

1.5. The Outline of the Research

This work is structured in four chapters as follow: chapter one displays a brief introduction, chapter two reviews the laser and nonlinear optics in general, chapter three shows the practical part, which include the materials and the method, while chapter four presents the results, discussion, conclusions and some recommendations about this research.

CHAPTER TWO

Introduction to Laser Physics and Nonlinear Optics (NLO)

2.1. Introduction

The first main section of this chapter is introduction to laser, which include a historical overview, basic construction and principle of lasing, Einstein coefficients, population inversion, properties of laser radiation , types of lasers, classification of lasers, and uses of lasers. The second main section is about nonlinear optics (NLO), which include a descriptions of nonlinear optical processes, the difference between linear optics and nonlinear optics, and the importance of nonlinear optics.

2.2. Introduction to Laser

The acronym LASER, constructed from Light Amplification by Stimulated Emission of Radiation, has become so common and popular in every day life that it is now referred to as laser [9].

2.2.1. Historical Development of Laser

The first theoretical foundation of LASER and MASER was given by Einstein in 1917 using Plank's law of radiation that was based on probability coefficients (Einstein coefficients) for absorption, spontaneous and stimulated emission of electromagnetic radiation. Theodore Maiman was the first to demonstrate the earliest practical laser in 1960 after the reports by several scientists. Maiman's first laser was based on optical pumping of synthetic ruby crystal using a flash lamp that generated pulsed red laser radiation at 694 nm. Iranian scientists Javan and Bennett made the first gas laser using a mixture of He and Ne gases in the ratio of (1 : 10) in the 1960 [9].

2.2.2. Basic Construction and Principle of Lasing

Every laser system essentially has an active/gain medium, placed between a pair of optically parallel and highly reflecting mirrors with one of them partially transmitting, and an energy source to pump active medium. The gain media may be solid, liquid, or gas and have the property to amplify the amplitude of the light wave passing through it by stimulated emission, while pumping may be electrical or optical. The gain medium used to place between pair of mirrors in such a way that light oscillating between mirrors passes every time through the gain medium and after attaining considerable amplification emits through the transmitting mirror.

Let us consider an active medium of atoms having only two energy levels: excited level E_2 and ground level E_1 . If atoms in the ground state, E_1 , are excited to the upper state, E_2 , by means of any pumping mechanism (optical, electrical discharge, passing current, or electron bombardment), then just after few nanoseconds of their excitation, atoms return to the ground state emitting photons of energy $h\nu = E_2 - E_1$. According to Einstein's 1917 theory, emission process may occur in two different ways, either it may induced by photon or it may occur spontaneously. The former case is termed as stimulated emission, while the latter is known as spontaneous emission. Photons emitted by stimulated emission have the same frequency, phase, and state of polarization as the stimulating photon; therefore, they add to the wave of stimulating photon on a constructive basis, thereby increasing its amplitude to make lasing. At thermal equilibrium, the probability of stimulated emission is much lower than that of spontaneous emission ($1:10^{33}$), therefore most of the conventional light sources are incoherent, and only lasing is possible in the conditions other than the thermal equilibrium [9].

2.2.3. Einstein coefficients

Consider an assembly of N_1 and N_2 atoms per unit volume with energies E_1 and E_2 ($E_2 > E_1$) is irradiated with photons of density $\rho(\nu) = N h\nu$, where $[N]$ is the number of photons of frequency ν per unit volume. Then the photon absorption (the process in which a photon is absorbed by the atom, causing an electron to jump from E_1 to E_2) and the stimulated emission (the process in which an electron is induced to jump from E_2 to E_1 by the presence of electromagnetic radiation at -or near- the frequency of the transition) rates may be written as :

$$\left(\frac{dN_1}{dt}\right)_{pos.absorb.} = -B_{12}N_1\rho(\nu) \quad (2.1)$$

$$\left(\frac{dN_2}{dt}\right)_{neg.abs.} = B_{21}N_2\rho(\nu) \quad (2.2)$$

respectively, where B_{12} and B_{21} are constants for up and downward transitions, respectively, between a given pair of energy levels. Rate of spontaneous transition (the process in which an electron spontaneously decays from E_2 to E_1) depends on the average lifetime of atoms in the excited state and is given by :

$$\left(\frac{dN_2}{dt}\right)_{spontaneous} = A_{21} N_2 \quad (2.3)$$

Where, A_{21} is a constant. Constants B_{12} , B_{21} , and A_{21} are known as Einstein coefficients [9].

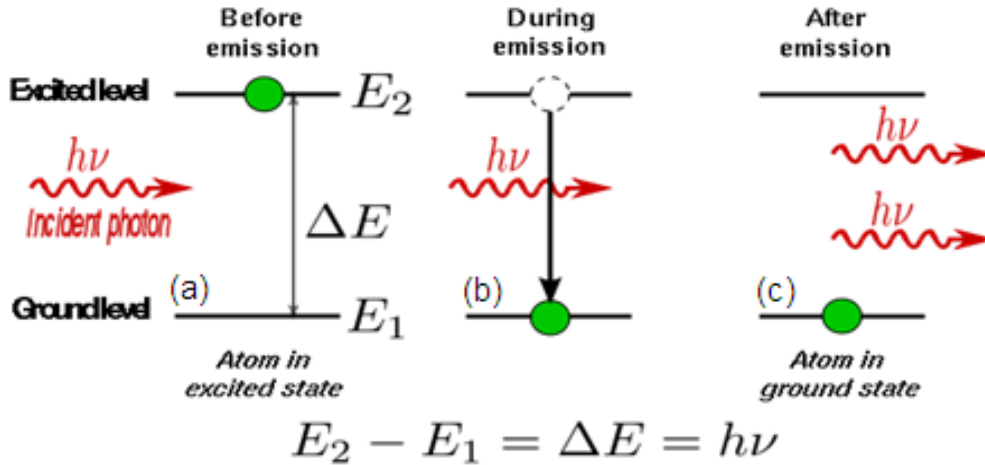

Fig. 2.1. Schematic illustration of the three processes: (a) absorption (b) spontaneous emission, (c) stimulated emission.

2.2.4 Population Inversion

A population inversion occurs while a system (such as a group of atoms or molecules) exists in a state in which more members of the system are in higher, excited states than in lower, unexcited energy states. It is called an "inversion" because in many familiar and commonly encountered physical systems, this is not possible. The concept is of fundamental importance in laser science because the production of a population inversion is a necessary step in the workings of a standard laser.

Assume there are a group of N atoms, each of which is capable of being in one of two energy states: either

1. The *ground state*, with energy E_1 ; or
2. The *excited state*, with energy E_2 , with $E_2 > E_1$.

The number of these atoms which are in the ground state is given by N_1 , and the number in the excited state N_2 . Since there are N atoms in total $N_1 + N_2 = N$, and the energy difference between the two states, given by $\Delta E_{21} = E_2 - E_1$. If the group of atoms is in thermal equilibrium, it can be

shown from Maxwell–Boltzmann statistics that the ratio of the number of atoms in each state is given by the ratio of two Boltzmann distributions, the Boltzmann factor:

$$\frac{N_2}{N_1} = e^{-\frac{\Delta E_{21}}{kT}} \quad (2.4)$$

where T is the thermodynamic temperature of the group of atoms, and k is Boltzmann's constant.

A population inversion ($N_2/N_1 > 1$) can never exist for a system at thermal equilibrium. To achieve population inversion therefore requires pushing the system into a non-equilibrated state [10].

A population inversion cannot be achieved with just two levels because the probability for absorption and for spontaneous emission is exactly the same, as shown by Einstein and expressed in the Einstein A and B coefficients.

2.2.5. Properties of Laser Beams

Laser comes in sizes ranging from approximately one tenth the diameter of a human hair to the size of a very large building, in powers ranging from 10^{-9} to 10^{20} W, and in wavelengths ranging from the microwave to the soft–X-ray spectral regions with corresponding frequencies from 10^{11} to 10^{17} Hz. Lasers have pulse energies as high as 10^4 J and pulse durations as short as 5×10^{-15} s. They can easily drill holes in the most durable of materials and can weld detached retinas within the human eye [2]. Laser radiation is characterized by an extremely high degree of monochromaticity, coherence, directionality, and brightness. To these properties a fifth can be added, which is, short time duration. This refers to the capability for producing very short light pulses, a property that, although perhaps less fundamental, is nevertheless very important. We

shall now consider these properties in some detail [11].

a. Monochromaticity

Theoretically, waves of light with single frequency ν of vibration or single wave-length λ is termed as single color or monochromatic light source. Practically, no source of light including laser is ideally monochromatic. Monochromaticity is a relative term. One source of light may be more monochromatic than others. Quantitatively, degree of monochromaticity is characterized by the spread in frequency of a line by ν , line width of the light source, or corresponding spread in wavelength λ . For small value of λ , frequency spreading, ν , is given as :

$$\Delta\nu = -(c/\lambda^2) \Delta\lambda \text{ and } \Delta\lambda = (c/\nu^2) \quad (2.5)$$

The most important property of laser is its spectacular monochromaticity [9].

b. Coherence

The basic meaning of coherence is that all the waves in the laser beam remain spatially and temporarily in the same phase. Photons generated through stimulated emission are in phase with the stimulating photons. For an ideal laser system, electric field of light waves at every point in the cross section of beam follows the same trend with time. Such a beam is called spatially coherent. Another type of coherence of the laser beam is temporal coherence, which defines uniformity in the rate of change in the phase of laser light wave at any point on the beam [9].

c. Directionality

One of the most striking properties of laser is its directionality, that is, its output is in the form of an almost parallel beam. Owing to its directional nature it can carry energy and data to very long distances for remote diagnosis and communication purposes. In contrast, conventional light sources emit radiation isotropically; therefore, very small amount of energy can be collected using lens. Beam of an ideal laser is perfectly parallel, and

its diameter at the exit window should be same to that after traveling very long distances, although in reality, it is impossible to achieve [9].

d. Brightness

Lasers are more intense and brighter sources compared to other conventional sources such as the sun. A 1mW He–Ne laser, which is a highly directional low divergence laser source, is brighter than the sun, which is emitting radiation isotropically [9]. Brightness is defined as power emitted per unit surface area per unit solid angle [11].

e. Short Time Duration

It is possible to produce light pulses whose duration is roughly equal to the inverse of the line-width of the 2 to1 transition. Thus, with gas lasers, whose line-width is relatively narrow, the pulse-width may be of (~ 0.1 – 1 ns). Such pulse durations are not regarded as particularly short and indeed even some flash-lamps can emit light pulses with a duration of somewhat less than 1 ns. On the other hand, the line-width of some solid state and liquid lasers can be 10^3 – 10^5 times larger than that of a gas laser, and, in this case, much shorter pulses may be generated (down to ~ 10 fs) [11].

2.2.6. Types of Lasers

Laser has many important types, some of these types are :

a. Gas lasers

A gas laser is a laser in which an electric current is discharged through a gas to produce coherent light. Early in the development of laser technology it was found that a mixture of helium and neon gases would lase in the infrared. Soon afterward, the familiar red transition of the helium–neon laser was found and so began the life of the most dominant laser for the next 20 years. The first gas laser, the helium–neon (He-Ne) laser, is still an important source of coherent red light with uses ranging from bar-code scanning to alignment. At one time the most popular laser, the dominance of this laser in the market is decaying rapidly, due to inexpensive, reliable,

and small semiconductor lasers operating in the same range of wavelengths and power levels as the He-Ne. He-Ne lasers normally operate with the familiar red (632.8 nm) beam, but multiple transitions are possible, allowing the laser to operate (with suitable optics) at wavelengths in the infrared, orange, yellow, and green. Power output for commercially available He-Ne tubes ranges from under 1 mW for a small He-Ne tube to just over 100 mW for a large behemoth unit. These lasers typically feature excellent spectral and coherence characteristics [12].

b. Solid-state lasers

The oldest technology, but one reborn recently and becoming increasingly important, is that of the optically pumped solid-state laser. Solid-state lasers (not to be confused with semiconductor lasers) consist of a crystal of glasslike material doped with a small concentration of a lasing ion such as chromium (in the case of ruby) or neodymium (in the case of YAG). The ruby laser, the first ever, was a reasonably simple structure with integral mirrors on a rod of synthetic ruby (chromium ions embedded into a host crystal of Al_2O_3) pumped with a helical flash-lamp. For many solid-state lasers the technology has not changed much, but in recent years more efficient materials with lower pumping thresholds have been used, and compact solid-state lasers have been developed that are pumped by semiconductor laser diodes instead of lamps. Many solid-state lasers have integral harmonic generator crystals to produce visible, even UV light. This technology promises to replace gas lasers for many applications. Although ruby lasers continue to be used in a few niche markets, most modern solid-state lasers use more efficient neodymium-doped crystals such as Nd:YAG or Nd:YVO₄. There are other solid-state materials of importance as well, such as erbium (used in fiber amplifiers for communications systems), holmium, and titanium (useful in a tunable solid-state laser) [12].

c. Semiconductor lasers

No laser has gained such widespread applications as the semiconductor (diode) laser. Found in applications ranging from laser pointers to DVD players, these tiny, efficient lasers have made possible many of the optical devices we take for granted. Consider that the very first CD players (built in the early 1980s) used a He-Ne gas laser. Such an arrangement is hardly portable and does not lend itself well to, say, an in-dash player in a car. As well as being tiny, these devices are also inexpensive and require only a simple power supply to operate. Although most laser diodes operate in the infrared or red regions of the spectrum, new diodes are being developed that can produce output in the blue and violet region of the spectrum, driven primarily by the need for a shorter wavelength for higher density optical storage than is currently possible with an infrared wavelength. Although the output characteristics of most laser diodes is not impressive compared to those of a gas laser, they do make excellent pump sources for solid-state lasers such as YAG or YV O₄ [12].

d. Dye lasers

In a dye laser the active lasing medium is an organic dye dissolved in a solvent such as alcohol. These lasers may be pumped by either flash-lamps (like a solid-state laser) or by another laser. Laser-pumped dye lasers normally employ nitrogen or excimer pump lasers and hence are pulsed, but continuous dye lasers are possible using a CW argon-ion laser as a pump source. The major advantage of this laser over other types is continuous tunability over a wide range. A laser employing rhodamine-6G, for example, can be tuned continuously through a range of wavelengths spanning visually from a shade of green–yellow to a shade of red. By changing the dye employed, the range can be selected. Hundreds of dyes are known to laser [12].

e. Infrared Gas Lasers

Of all infrared gas lasers, the carbon dioxide laser is by far the most commonly used, with other gases, such as nitrous oxide (N₂O) and carbon monoxide (CO), used less frequently. Most mid-IR molecular lasers operating in the wavelength range 2 to 20 mm involve vibrational energy levels that result when bonds between atoms in these molecules bend or stretch. Longer wavelengths are possible in a molecular laser as well, but these involve purely rotational transitions with correspondingly lower energy levels [12].

2.2.7. Laser Classifications

Lasers have been classified by wavelength and maximum output power into four classes and a few subclasses. The classifications categorize lasers according to their ability to produce damage in exposed people, from class 1 (no hazard during normal use) to class 4 (severe hazard for eyes and skin).

a. Class I

Lasers Class I lasers include the self-contained (enclosed) systems (such as those used in laboratories for diagnostic work) that do not inflict harm under normal circumstances. These lasers do not require hazard-warning labeling because the laser output is at or below the acceptable emission limits.

b. Class II Lasers

Class II lasers are low-powered devices that emit visible laser light (for example, the helium-neon laser). The normal aversion reflex, such as blinking or turning the head, provides adequate protection against Class II lasers. These lasers are safe for momentary viewing, but constant, deliberate viewing without eye protection could cause

degenerative eye changes, especially if the aversion reflex is absent. A sedated patient may have a compromised aversion response and should be protected against a laser port that may emit a helium-neon aiming beam.

c. Class III Lasers

Class III lasers require special training to operate and have the potential to cause injury if viewed directly or if specularly reflected. Some ophthalmology Nd:YAG lasers are listed as Class III lasers.

d. Class IV Lasers

Most lasers used in medicine and surgery are Class IV lasers (CO₂, argon, continuous wave, Nd:YAG). These lasers are potentially hazardous and could cause fire, skin burns and optical damage from either direct or scattered radiation. Specific safety measures must be employed to prevent injury from Class IV lasers [13].

2.2.8. Lasers Applications

When lasers were invented in 1960, they were called "a solution looking for a problem" [14]. Since then, they have become ubiquitous, finding utility in thousands of highly varied applications in every section of modern society. They are a key component of some of our most modern communication systems (Fiber-optic communication using lasers is a key technology in modern communications, allowing services such as the Internet), and are the "phonograph needle" of our compact disc players. They perform heat treatment of high-strength materials, such as the pistons of our automobile engines, and provide a special surgical knife for many types of medical procedures. They act as target designators for military weapons and provide for the rapid check-out we have come to expect at the supermarket [2].

2.3. Nonlinear Optics (NLO)

Nonlinear optics is the study of phenomena that occur as a consequence of the modification of the optical properties of a material system by the presence of light. Typically, only laser light is sufficiently intense to modify the optical properties of a material system. The beginning of the field of nonlinear optics is often taken to be the discovery of second-harmonic generation by Franken et al. (1961), shortly after the demonstration of the first working laser by Maiman in 1960. Nonlinear optical phenomena are “nonlinear” in the sense that they occur when the response of a material system to an applied optical field depends in a nonlinear manner on the strength of the optical field. For example, second-harmonic generation occurs as a result of the part of the atomic response that scales quadratically with the strength of the applied optical field. Consequently, the intensity of the light generated at the second-harmonic frequency tends to increase as the square of the intensity of the applied laser light [4]. Nonlinear optics explains nonlinear response of properties such as frequency, polarization, phase or path of incident light.

In order to describe more precisely what we mean by an optical nonlinearity, let us consider how the dipole moment per unit volume, or polarization $\mathbf{P}(t)$, of a material system depends on the strength $\mathbf{E}(t)$ of an applied optical field. In the case of conventional (i.e., linear) optics, the induced polarization depends linearly on the electric field strength in a manner that can often be described by the relationship

$$\mathbf{P}(t) = \epsilon_0 \chi^{(1)} \mathbf{E}(t), \quad (2.6)$$

where the constant of proportionality $\chi^{(1)}$ is known as the linear susceptibility and ϵ_0 is the permittivity of free space. In nonlinear optics, the optical response can often be described by generalizing Eq. (2.6) by expressing the polarization $\mathbf{P}(t)$ as a power series in the field strength $\mathbf{E}(t)$

as

$$\begin{aligned} \mathbf{P} &= \epsilon_0 [\chi^{(1)} \mathbf{E}(t) + \chi^{(2)} \mathbf{E}^2(t) + \chi^{(3)} \mathbf{E}^3(t) + \dots] \\ &\equiv \mathbf{P}^{(1)}(t) + \mathbf{P}^{(2)}(t) + \mathbf{P}^{(3)}(t) + \dots . \end{aligned} \quad (2.7)$$

The quantities $\chi^{(2)}$ and $\chi^{(3)}$ are known as the second- and third-order nonlinear optical susceptibilities, respectively.

The most usual procedure for describing nonlinear optical phenomena is based on expressing the polarization $\mathbf{P}(t)$ in terms of the applied electric field strength $\mathbf{E}(t)$, as we have done in Eq. (2.7). The reason why the polarization plays a key role in the description of nonlinear optical phenomena is that a time-varying polarization can act as the source of new components of the electromagnetic field. For example, the wave equation in nonlinear optical media often has the form

$$\nabla^2 \mathbf{E} - \frac{n^2}{c^2} \frac{\partial^2 \mathbf{E}}{\partial t^2} = \frac{1}{\epsilon_0 c^2} \frac{\partial^2 \mathbf{P}^{NL}}{\partial t^2} \quad (2.8)$$

where n is the usual linear refractive index and c is the speed of light in vacuum. We can interpret this expression as an inhomogeneous wave equation in which the polarization \mathbf{P}^{NL} associated with the nonlinear response drives the electric field \mathbf{E} . Since $\partial^2 \mathbf{P}^{NL} / \partial t^2$ is a measure of the acceleration of the charges that constitute the medium, this equation is consistent with Larmor's theorem of electromagnetism, which states that accelerated charges generate electromagnetic radiation [4].

2.3.1. Descriptions of Nonlinear Optical processes

In the present section, we present brief qualitative descriptions of a number of nonlinear optical processes. In addition, for those processes that can occur in a lossless medium, we indicate how they can be described in terms of the nonlinear contributions to the polarization described by Eq. (2.7). Our motivations is to provide an indication of the variety of nonlinear optical phenomena that can occur. In this section, we introduce some

notational conventions and some of the basic concepts of nonlinear optics [4].

a. Second-Harmonic Generation

Let us consider the process of second-harmonic generation, which is illustrated schematically in Fig (2.2) Here a laser beam whose electric field strength is represented as

$$\mathbf{E}(t) = Ee^{-i2\omega t} + \text{c. c.} \quad (2.9)$$

is incident upon a crystal for which the second-order susceptibility $\chi^{(2)}$ is nonzero. The nonlinear polarization that is created in a crystal is given according to Eq. (2.7) as $\mathbf{P}^{(2)}(t) = \epsilon_0\chi^{(2)}\mathbf{E}^{(2)}(t)$ or explicitly as

$$\mathbf{P}^{(2)}(t) = 2\epsilon_0\chi^{(2)}EE^* + (\epsilon_0\chi^{(2)}E^2e^{-i2\omega t} + \text{c. c.}) \quad (2.10)$$

We see that the second-order polarization consists of a contribution at zero frequency (the first term) and a contribution at frequency 2ω (the second term). According to the driven wave equation (2.8), this latter contribution can lead to the generation of radiation at the second –harmonic frequency . Note that the first contribution in Eq. (2.10) does not lead to the generation of electromagnetic radiation (because its second time derivative vanishes); it leads to a process known as optical rectification , in which a static electric field is created across the nonlinear crystal [4].

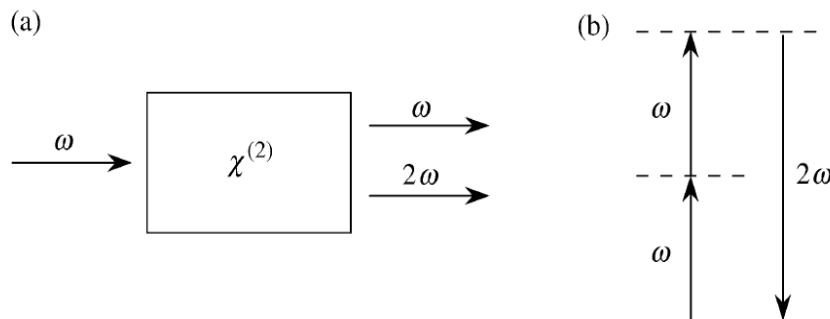

Fig. 2.2. (a) Geometry of second-harmonic generation. (b) Energy-level diagram describing second-harmonic generation.

b. Sum-and Difference-Frequency Generation

Let us consider the circumstance in which the optical field incident upon a second – order nonlinear optical medium consist of two distinct frequency components ,which we represent in the form

$$\mathbf{E}(t) = E_1 e^{-i\omega_1 t} + E_2 e^{-i\omega_2 t} + c.c. \quad (2.11)$$

Then, assuming as in Eq. (2.7) that the second –order contribution to the nonlinear polarization is the form

$$\mathbf{P}^{(2)}(t) = \epsilon_0 \chi^{(2)} \mathbf{E}(t)^2 \quad (2.12)$$

We find that the nonlinear polarization is given by

$$\begin{aligned} \mathbf{P}^{(2)}(t) = \epsilon_0 \chi^{(2)} [& E_1^2 e^{-2i\omega_1 t} + E_2^2 e^{-2i\omega_2 t} + 2E_1 E_2 e^{-i(\omega_1 + \omega_2)t} \\ & + 2E_1 E_2^* e^{-i(\omega_1 - \omega_2)t} + c.c.] + 2\epsilon_0 \chi^{(2)} [E_1 E_1^* + E_1 E_2^*] \end{aligned} \quad (2.13)$$

It is convenient to express this result using the notation

$$\mathbf{P}^{(2)}(t) = \sum_n p(\omega_n) e^{-i\omega_n t} \quad (2.14)$$

Where the summation extends over positive and negative frequencies ω_n . The complex amplitudes of the various frequency components of the nonlinear polarization are hence given by

$$\begin{aligned} p(2\omega_1) &= \epsilon_0 \chi^{(2)} E_1^2 \quad (SHG), \\ p(2\omega_2) &= \epsilon_0 \chi^{(2)} E_2^2 \quad (SHG), \\ p(\omega_1 + \omega_2) &= 2\epsilon_0 \chi^{(2)} E_1 E_2 \quad (SFG), \\ p(\omega_1 - \omega_2) &= 2\epsilon_0 \chi^{(2)} E_1 E_2^* \quad (DFG), \\ p(0) &= 2\epsilon_0 \chi^{(2)} (E_1 E_1^* + E_2 E_2^*) \quad (OR). \end{aligned} \quad (2.15)$$

Here we have labeled each expression by the name of the physical process that it describes, such as second-harmonic generation (SHG), sum-frequency generation (SFG), difference –frequency generation (DFG),and optical rectification (OR). Note that, in accordance with our complex notation, there is also a response at the negative of each of the nonzero frequencies just given [4]

$$\begin{aligned}
p(-2\omega_1) &= \epsilon_0 \chi^{(2)} E_1^{*2}, & p(-2\omega_2) &= \epsilon_0 \chi^{(2)} E_2^{*2}, \\
p(-\omega_1 - \omega_2) &= 2\epsilon_0 \chi^{(2)} E_1^* E_2^*, & p(\omega_2 - \omega_1) &= 2\epsilon_0 \chi^{(2)} E_2 E_1^*.
\end{aligned}
\tag{2.16}$$

c. Sum-Frequency Generation

Let us consider the process of sum-frequency generation, which is illustrated in Fig. 2.3. According to Eq. (2.15), the complex amplitude of the nonlinear polarization describing this process, is given by the expression

$$p(\omega_1 + \omega_2) = 2\epsilon_0 \chi^{(2)} E_1 E_2. \tag{2.17}$$

In many ways the process of sum-frequency generation is analogous to that of second-harmonic generation, except that in sum-frequency generation the two input waves are at different frequencies [4].

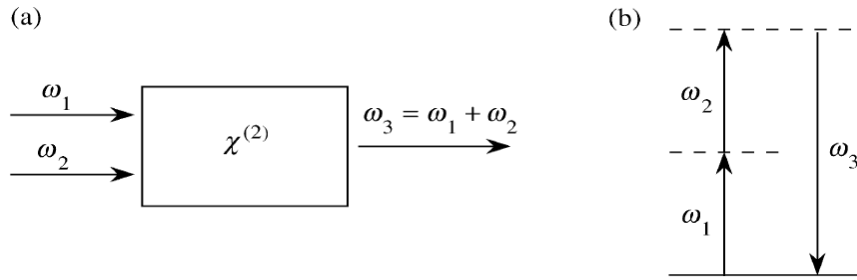

Fig. 2.3. Sum-frequency generation. (a) Geometry of the interaction. (b) Energy-level description.

d. Difference-Frequency Generation

The process of difference-frequency generation is described by a nonlinear polarization of the form

$$p(\omega_1 - \omega_2) = 2\epsilon_0 \chi^{(2)} E_1 E_2^* \tag{2.18}$$

and is illustrated in Fig. 2.4. Here the frequency of the generated wave is the difference of those of the applied fields. However, the important

difference between the difference-frequency and sum-frequency generation can be deduced from the description of difference-frequency generation in terms of a photon energy-level diagram (part (b) of Fig. 2.4). We see that conservation of energy requires that for every photon that is created at the difference frequency $\omega_3 = \omega_1 - \omega_2$, a photon at the higher input frequency (ω_1) must be destroyed and a photon at the lower input frequency (ω_2) must be created. Thus, the lower frequency input field is amplified by the process of difference-frequency generation. For this reason, the process of difference-frequency generation is also known as optical parametric amplification [4].

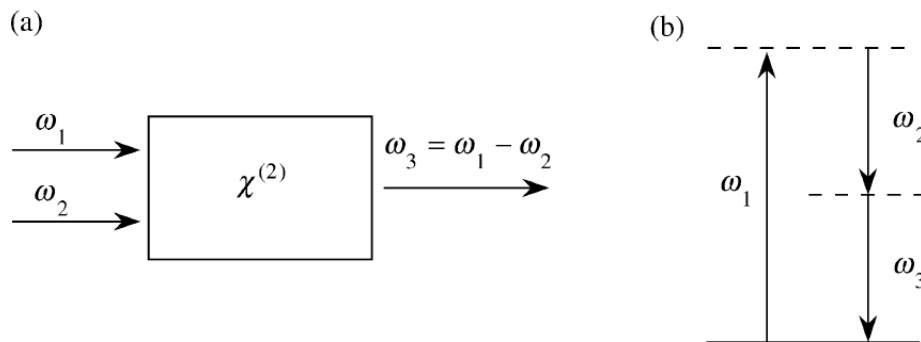

Fig. 2.4. Difference-frequency generation. (a) Geometry of the interaction. (b) Energy-level description.

e. Optical Parametric Oscillation

We have just seen that in the process of difference-frequency generation the Presence of radiation at frequency ω_2 or ω_3 can stimulate the emission of additional photons at these frequencies. If the nonlinear crystal used in this process is placed inside an optical resonator, as shown in Fig. 2.5, the ω_2 and/or ω_3 fields can build up to large values. Such a device is known as an optical Parametric oscillator. Optical parametric oscillators are frequently used at Infrared wavelengths, where other sources of tunable radiation are not readily available. Such a device is tunable because any

frequency ω_2 that is smaller than ω_1 can satisfy the condition $\omega_2 + \omega_3 = \omega_1$ for some frequency ω_3 [4].

f. Third-Order Nonlinear Optical Processes

We next consider the third-order contribution to the nonlinear polarization

$$\mathbf{P}^{(3)}(t) = \epsilon_0 \chi^{(3)} \mathbf{E}(t)^3 \quad (2.19)$$

For the general case in which the field $\mathbf{E}(t)$ is made up of several different frequency components, the expression for $\mathbf{P}^{(3)}(t)$ is very complicated. For this reason, we first consider the simple case in which the applied field is monochromatic and is given by

$$\mathbf{E}(t) = \epsilon \cos \omega t \quad (2.20)$$

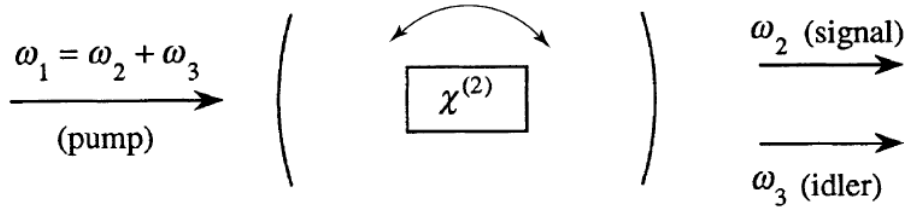

Fig. 2.5. The optical parametric oscillator. The cavity end mirrors have high reflectivities at frequencies ω_2 and/or ω_3 . The output frequencies can be tuned by means of the orientation of the crystal.

Then, through use of the identity $\cos^3 \omega t = \frac{1}{4} \cos 3\omega t + \frac{3}{4} \cos \omega t$, we can express

the nonlinear polarization as

$$\mathbf{P}^{(3)}(t) = \frac{1}{4} \epsilon_0 \chi^{(3)} \epsilon^3 \cos 3\omega t + \frac{3}{4} \epsilon_0 \chi^{(3)} \epsilon^3 \cos \omega t \quad (2.21)$$

The significance of each of the two terms in this expression is described briefly below [4].

g. Third-Harmonic Generation

The first term in Eq. (2.21) describes a response at frequency 3ω that is created by an applied field at frequency ω . This term leads to the process of third-harmonic generation, which is illustrated in Fig. 2.6. According to the photon description of this process, shown in part (b) of the figure, three photons of frequency ω are destroyed and one photon of frequency 3ω is created in the microscopic description of this process [4].

h. Intensity-Dependent Refractive Index

The second term in Eq. (2.21) describes a nonlinear contribution to the polarization at the frequency of the incident field; this term hence leads to a nonlinear contribution to the refractive index experienced by a wave at frequency ω . The refractive index in the presence of this type of nonlinearity can be represented as

$$n = n_0 + n_2 I, \quad (2.22)$$

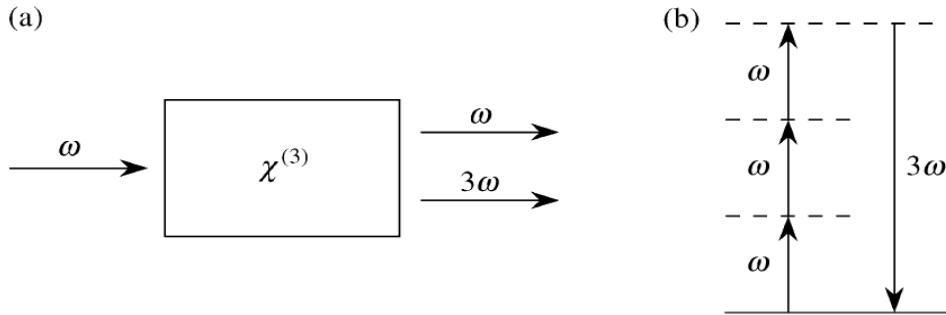

Fig. 2.6. Third-harmonic generation. (a) Geometry of the interaction. (b) Energy-level description.

where n_0 is the usual (i.e., linear or low-intensity) refractive index, where

$$n_2 = \frac{3}{2n_0^2 \epsilon_0 c} \chi^{(3)} \quad (2.23)$$

is an optical constant that characterizes the strength of the optical nonlinearity, and where $I = \frac{1}{2}n_0\epsilon_0c\epsilon^2$ is the intensity of the incident wave [4].

2.3.2. The difference between Linear Optics and Non-Linear Optics

- In linear optics (as we can call it Optics of weak light), light is deflected or delayed but its frequency remain unchanged, and the polarization can be given by

$$\vec{P} = \epsilon_0\chi\vec{E} \quad (2.24)$$

If monochromatic light enters an unchanging linear-optical system, the output will be at the same frequency. The superposition principle is valid for linear-optical systems.

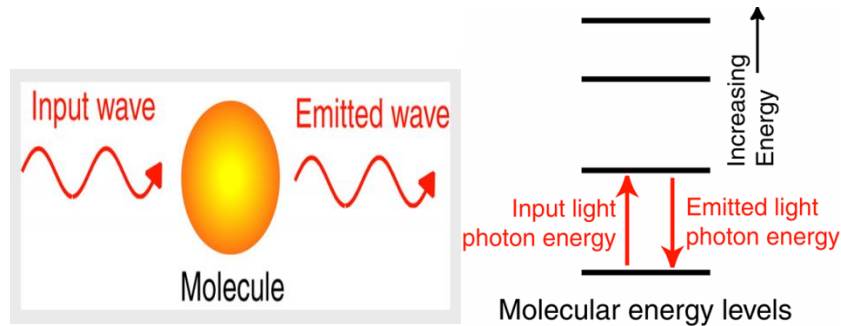

Fig. 2.7. A light wave acts on a molecule, which vibrates and then emits its own light wave that interferes with the original light wave.

- In non-Linear optics (or as we can call it Optics of intense light), we are concerned with the effects that light itself induces as it propagates through the medium, and the polarization is given by

$$\mathbf{P} = \epsilon_0[\chi^{(1)}\mathbf{E}(t) + \chi^{(2)}\mathbf{E}^2(t) + \chi^{(3)}\mathbf{E}^3(t) + \dots] \quad (2.25)$$

$\mathbf{P} \equiv$ induced polarization of medium.

$\epsilon_0 \equiv$ dielectric constant of vacuum.

$\mathbf{E} \equiv$ electric field.

$\chi^{(i)}$ \equiv susceptibilities of ‘ i ’ order.

Nonlinear optics allows us to change the color of a light beam, to change its shape in space and time, to switch telecommunications systems.

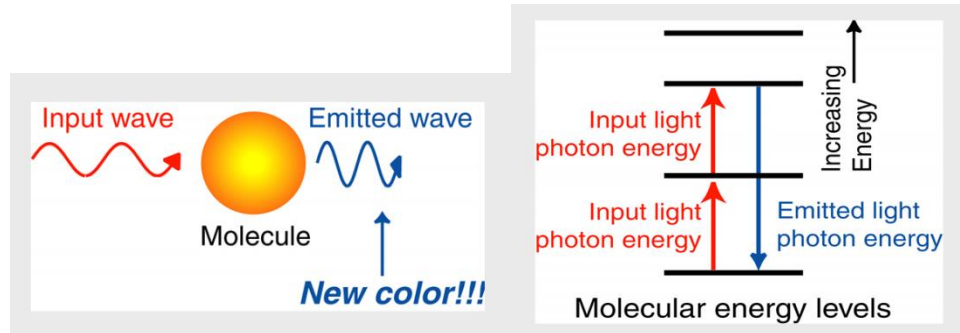

Fig. 2.8. If irradiance is high enough, vibrations at all frequencies corresponding to all energy differences between populated states are produced.

2.3.3. Importance of Nonlinear Optics

Nonlinear optics is becoming one of the most important fields in our modern era. Optical wave manipulation is one of the future technologies for optical processing. It has various applications in fiber-optic communications and optoelectronics which makes it an increasingly important topic among electrical engineers.

CHAPTER THREE

Materials, Apparatus and Method

3.1. Materials

We will use a glass sample with dimensions (5x5) cm and thickness of 5mm. The type of the glass sample is a Soda-Lime glass (high density, low strength, low cost, e.g. beverage containers, window glass).

Soda-lime glass (sand 63-74%, soda ash 12-16% and limestone 7-14%) is prepared by melting the raw materials, such as sodium carbonate (soda), lime, dolomite, silicon dioxide (silica), aluminium oxide (alumina), and small quantities of fining agents (e.g., sodium sulfate, sodium chloride) in a glass furnace at temperatures locally up to 1675°C [15].

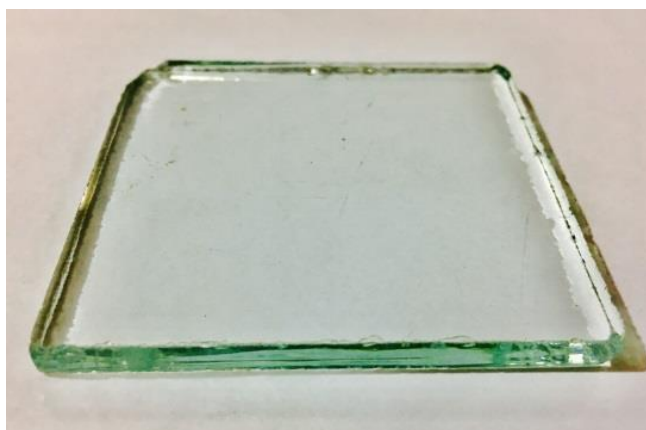

Fig. 3.1. Soda-lime glass sample.

3.2. Apparatus

3.2.1. He-Ne Laser

The type of laser that was used is a He-Ne laser, which is a type of gas laser whose gain medium consists of a mixture of 85% helium and 15%

neon inside of a small bore capillary tube, and usually excited by a DC electrical discharge. It operates at a wavelength of 632.8 nm, in the red part of the visible spectrum, with an optical output power of 1mW. It also operates a continuous wave (cw) and has a very stable low-noise output.



Fig. 3.2. He-Ne laser device.

3.2.2. Photo-detector

The device that was used to detect the change in the intensity of the He-Ne laser light is a photo-detector, which is a device that convert photons into electric current by means of “electron-hole” pair generation subsequent to the absorption of light by a semiconductor material. Presently, the most commonly used material is silicon.



Fig. 3.3. Photo-detector device.

3.2.3. Electric Heater

The Heating source that was used is a -commonly used- electric heater, which is an electrical device that converts electric current to heat. Its maximum temperature can reach up to 150°C degrees.



Fig. 3.4. Electric heater device.

3.3. Method

The equipments were rearranged as in figure 3.5.

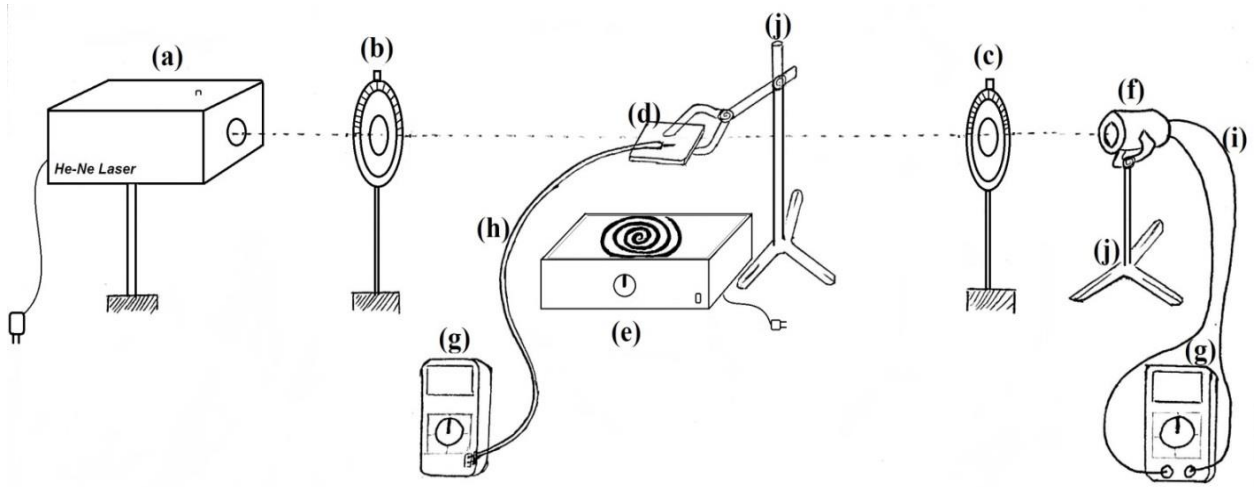

Fig. 3.5. Shows the setup of the experiment : (a) He-Ne Laser (632.6nm, 1mW), (b) Polarizer, (c) Analyzer, (d) glass sample, (e) Electric Heater, (f) Photo-detector, (g) Digital Multi-meters, (h) Thermocouple, (i) Wires, (j) Stand.

The glass sample was positioned perpendicular to an electric heater and at a suitable height (10 cm) above it, then a He-Ne laser was applied to the glass sample. A photo-detector was placed behind the sample, so that the laser light that comes out of the glass falls on the detector. In front of the source there is a polarizer to adjust the laser's degree of polarization. Firstly, room temperature was measured using a thermocouple and it was found to be 25°C, and also the initial current was measured using a digital multi-meter and it was found to be 4 μ A. After that, the glass sample was heated starting with $T = 30^\circ\text{C}$, so that the experiment was done by increasing the temperature by 5 degrees each time. The current corresponding to each temperature reading, was recorded until reaching $T = 100^\circ\text{C}$. The same process was done with cooling the temperature every 5 degrees and the results was tabulated in table 4.1.

CHAPTER FOUR

Results, Discussion, Conclusion and Recommendations

4.1. Results

The obtained results was tabled as shown in table 4.1, and it shows the currents intensity I (μA) readings (in the case of heating (h), and cooling (c)) corresponding to each temperature T ($^{\circ}\text{C}$), where a clear fluctuation in the intensity of currents readings was observed .

Table 4.1. Shows the current intensity I (μA) readings (in the case of heating (h), and cooling (c)) corresponding to each temperature T ($^{\circ}\text{C}$).

$T/^{\circ}\text{C}$	$I_h/\mu\text{A}$	$I_c/\mu\text{A}$
30	4.4	6.0
35	4.6	6.3
40	4.5	6.0
45	4.5	6.5
50	4.6	6.3
55	4.7	6.6
60	4.6	6.9
65	4.5	6.7
70	4.4	6.7
75	4.8	6.5
80	4.8	6.6
85	5.6	6.4

T/°C	$I_h/\mu\text{A}$	$I_c/\mu\text{A}$
90	5.3	6.2
95	5.4	6.0
100	5.5	6.3

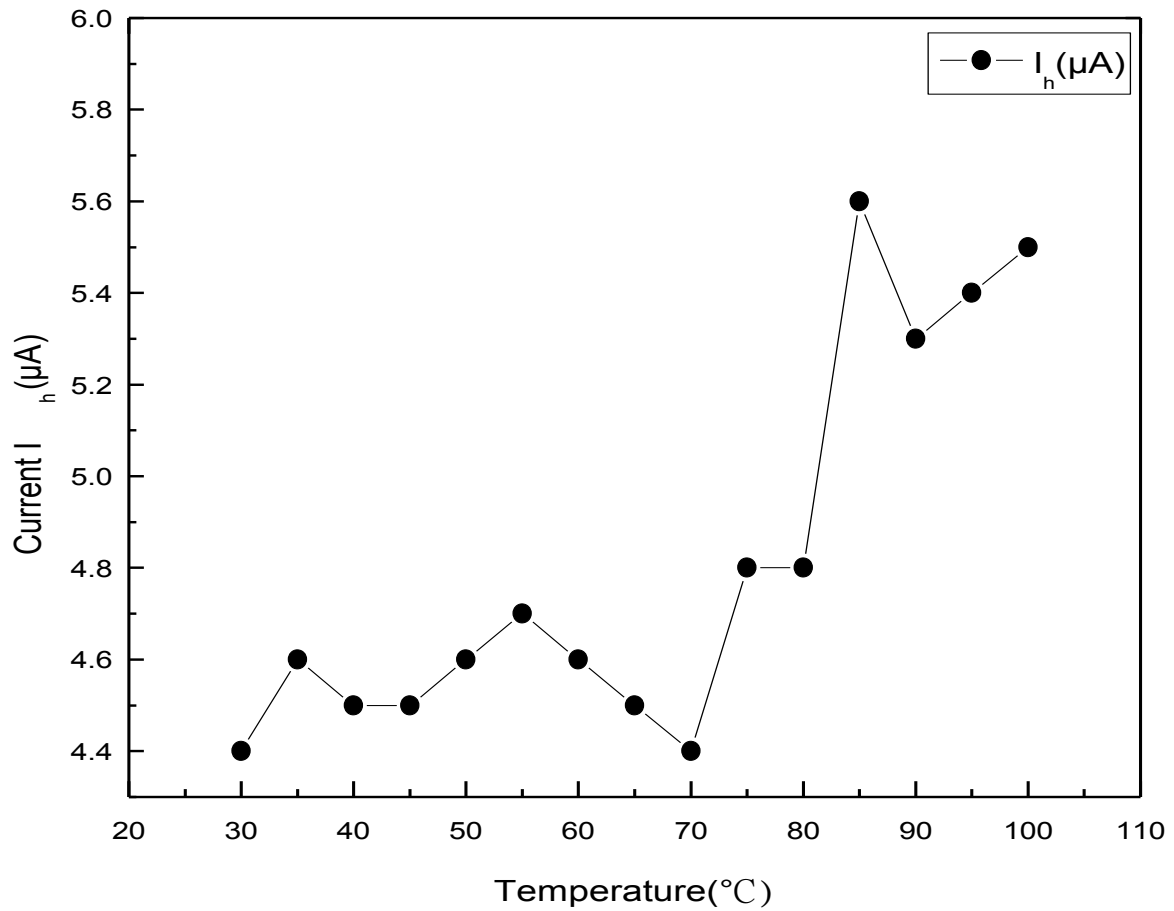

Fig. 4.1. A graph showing the relationship between temperature ($^{\circ}\text{C}$) in the case of heating against current intensity I_h (μA), where the curve shows that the relationship between them is not linear. Heat increases the kinetic energy of glass particles by vibration of molecules. This vibration may increase the susceptibility of glass to absorb light or may turn it into a non-linear material. Also it is noticeable that the highest peak of the change when the temperature was 85°C .

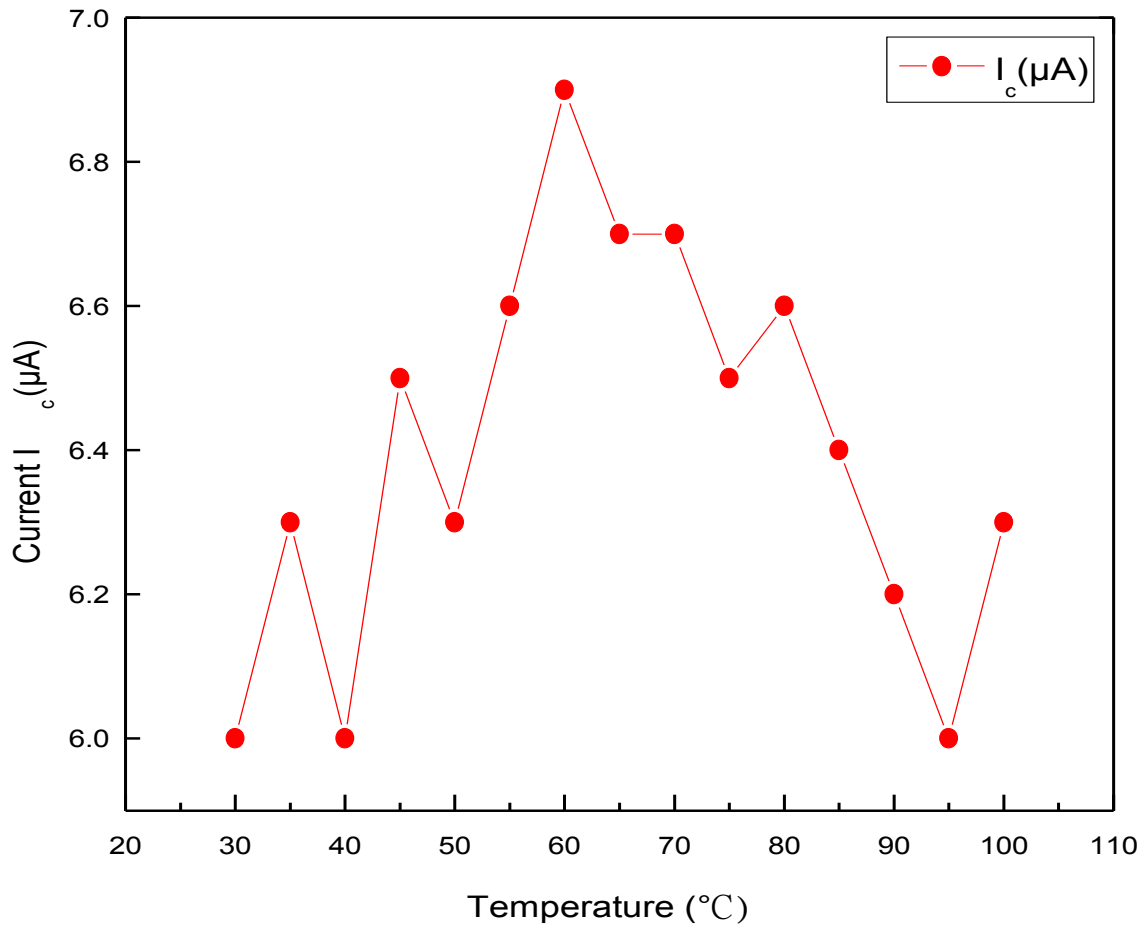

Fig. 4.2. A graph Showing the relationship between temperature ($^{\circ}\text{C}$) in the case of cooling against current intensity I_c (μA), where the curve clearly shows that the relationship between them is not linear. It is noticeable here that, although the process is a cooling process, the glass has maintained its non-linear behavior, and hasn't returned to its normal state; which could mean the effect is still existing even after the cooling process has ended.

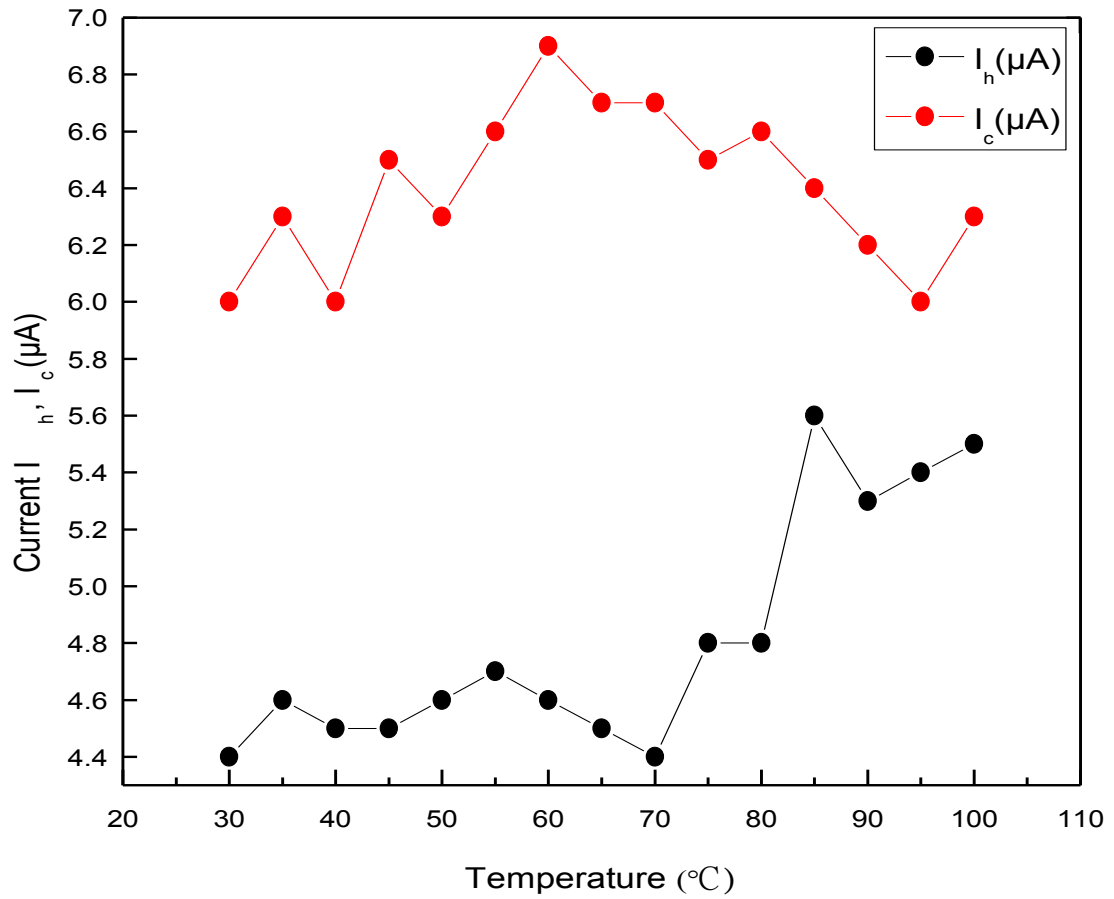

Fig. 4.3. A graph showing the relationship between temperature ($^{\circ}\text{C}$) in the case of heating and cooling against current intensity I_h, I_c (μA). The red line represent the heating case, and the blue line represent the cooling case.

4.2. Discussion

From table 4.1, It was noticeable that there was a clear fluctuation in current readings, which indicates that the glass susceptibility to absorb light had changed. This confirm that the optical properties of the glass has changed. Heat increases the kinetic energy of glass particles by vibration of molecules. This vibration may increase the susceptibility of glass to absorb light or may turn it into a non-linear material. From figure 4.1, it is noticeable that the highest peak of the change when the temperature was 85°C. And From figure 4.2, It is noticeable that, although the process is a cooling process, the glass has maintained its non-linear behavior, and hasn't returned to its normal state, which could mean the effect is still existing even after the cooling process has ended. Also, from figure 4.3, and after analyzing it, the nonlinear curves will clearly indicates the non-linearity behavior of the glass sample under variations of temperature.

4.3. Conclusions

From results and graphs, we concluded that the optical properties of the glass has changed, and the glass behaves nonlinearly through heating and cooling processes (from $T = 85^{\circ}\text{C}$ until the end of the cooling process).

4.4. Recommendations

Through the results obtained in this study, and due to time constraints and difficulty in providing some devices, one can mention some important recommendations:

- ❖ The method which was used to convert the optical materials such as glass into nonlinear ones by means of temperature changing is not effective for application purposes (in case of heating and cooling delay). Therefore, it is difficult to control the transformation process as it doesn't occur instantaneously as our needs, but it occurs at a certain temperature varies according to the material. So the effective way is by applying a high-energy pulse laser or infra-red laser such as Nd-Yag laser to a glass plate or an optical fiber, then connecting the detector with Cathode Ray Oscilloscope (CRO) using an interface unit to measure different changes in He-Ne signal as amplitude broadening. Also a simple measurement can be done using digital multi-meters to read the micro current that generated from the detector due to the He-Ne signal and read the difference in current due to the interception signal from the Nd-Yag laser (it will be difficult to read it using naked eyes as the Nd-Yag pulse is fast, therefore it can be done by video recording on the digital multi-meter, which is also difficult in the case of CRO and it will be useful to video record the CRO screen and then using slow motion to capture the shift moments).
- ❖ Also, a high electric field can be applied to the glass or the optical fiber, by putting them between two parallel plates connected to a high voltage source (can be controlled by frequency or amplitude).
- ❖ We recommend repeating this experiment using different optical materials, by applying either heating source or Nd-Yag laser to

investigate whether these materials behaves linearly or nonlinearly, and the ability to convert these materials from a linear to non-linear optical materials.

4.5. References

- [1] Hecht, Jeff. (1992). *Laser Pioneers*. Revised Edition. California, USA: Academic Press.
- [2] Silfvast, William. (2004). *Laser Fundamentals*. 2nd ed. Cambridge University press.
- [3] Glass. (2017,September,19). In *Wikipedia, The Free Encyclopedia*. Retrieved 19:41,September,192017, from <https://en.wikipedia.org/w/index.php?title=Glass&oldid=801426708>
- [4] Boyd, Robert. (2007). *Nonlinear Optics*. 3rd ed. Rochester, New York: Academic Press.
- [5] Marder, S. R et al. (1991). *Materials for Nonlinear Optics. Chemical Perspectives*, ACS Symposium Series 455. American Chemical Society, Washington DC.
- [6] P.A. Franken et al., *Phys. Rev. Letters*, 1961, 7(4), 118.
- [7] a) T.H. Maiman, *Nature*. (1960), 187, 493; b) R.J. Collins et al., *Phys. Rev. Letters*, 1960, 5(7), 303.
- [8] Bloembergen, Nicolaas. (1965). *Nonlinear Optics*. New York, Amsterdam: W. A. Benjamin Inc.
- [9] Subhash Chandra Singh,etal. (2012). *Nanomaterials: Processing and Characterization with Lasers - Lasers: Fundamentals, Types, and Operations*. Wiley.
- [10] Svelto, Orazio. (1998). *Principles of Lasers*, 4th ed. (trans. David Hanna), Springer.

[11] Svelto, Orazio. (2010). Principles of Lasers. 5th ed. Heidelberg, Springer.

[12] Csele, Mark. (2004). Fundamental of Light Sources and Lasers. New Jersey, John Wiley & Sone, Inc.

[13] A. Ball, Kay. (1995). Lasers: The Perioperative Challenge. 2nd ed. Ohio, United Medical Network, Lewis Center.

[14] Charles H. Townes (2003). "The first laser". In Laura Garwin; Tim Lincoln. A Century of Nature: Twenty-One Discoveries that Changed Science and the World. University of Chicago Press. Retrieved February 2, 2008.

[15] B. H. W. S. de Jong. (1989). "Glass"; in "Ullmann's Encyclopedia of Industrial Chemistry"; 5th edition, vol. A12, VCH Publishers, Weinheim, Germany.