

SUDAN UNIVERSITY OF SCIENCE AND TECHNOLOGY
COLLEGE OF GRADUATE STUDIES



Design and Implementation of Gearbox Test Rig for Heavy Vehicles

تصميم وتنفيذ جهاز اختبار صندوق تروس الآليات الثقيلة

*A thesis Submitted to the College of Graduate Studies in Partial
Fulfillment of the Requirements for the Degree of M.Sc. in Mechanical
Engineering (Production)*

Prepared by:

Yasir Hussein Younis

Supervisor:

Dr. Abdalfatah Belal

Sep. 2017

آية قرآنية

قال تعالى:

بسم الله الرحمن الرحيم

{هُوَ الَّذِي أَنْزَلَ عَلَيْكَ الْكِتَابَ مِنْهُ آيَاتٌ مُحْكَمَاتٌ هُنَّ أُمُّ الْكِتَابِ
وَأُخَرُ مُتَشَابِهَاتٌ فَأَمَّا الَّذِينَ فِي قُلُوبِهِمْ زَيْغٌ فَيَتَّبِعُونَ مَا تَشَابَهَ مِنْهُ
ابْتِغَاءَ الْفِتْنَةِ وَابْتِغَاءَ تَأْوِيلِهِ وَمَا يَعْلَمُ تَأْوِيلَهُ إِلَّا اللَّهُ وَالرَّاسِخُونَ
فِي الْعِلْمِ يَقُولُونَ آمَنَّا بِهِ كُلٌّ مِّنْ عِنْدِ رَبِّنَا وَمَا يَذَّكَّرُ إِلَّا أُولُو
الْأَلْبَابِ}

صدق الله العظيم

سورة آل عمران
الآية (7)

Dedication

To the one who will make my heart happy with her.
To the flower garden that sprout flowers blossoms
My mother

To the symbol of manhood and sacrifice
To those who pushed me to science and posted more
My father

To the one who is closest to my heart
To the one who is shared my thoughts and by her
I draw my strength and my determination
My wife

To those who share with me the bosom of pain and by them
I draw my strength and my determination
My brothers

I was in my studies and shared my thoughts memorial and appreciation
My friends

To this young and mighty scientific edifice
Sudan University

Acknowledgements

I would like first to thank my advisor, Dr. AbdelfattahBilal, for his enthusiasm on this subject, his many insights, encouragement, and invaluable guidance.

Thanks also extended to:

Sudan University of Science and technology-College of Engineering, School of Mechanical Engineering

MyEmployer Company for giving me a chance for this study.

I wish also to acknowledge the assistance of the following people:

* Engineer Yasir Ibrahim for his useful discussions and information in the design and valuable references.

* EngineerAbdallah Altahir for his help in the design and drawing.

Special thanks to my friend EngineerZied Salaheldeen forhis help and assistance infinal writing touches.

Finally yet importantly, I would like to thank my family and friends for their continual love and support.

Abstract

During repairing and troubleshooting gearboxes, a way to check and inspect its performance before and after repairs is needed. However, while the engine tester (Dynamometers) are very generic and common and does not need to vary according to the engine manufacturer and model, the gearbox is very customized to the vehicle type, engine type, output required, and drive configuration. Therefore, there is a need to design a customized apparatus in order to accommodate the required procedures needed to complete the diagnostic of the gearbox performance. Customized gearbox testing devices may be imported but are very expensive; therefore, the need to design a device or apparatus for testing the gearboxes used in the working vehicles in the fleet of the company is raised. In this research, a simple, efficient gearbox performance testing apparatus for a specific vehicle gearbox. An A C motor to replace the engine was designed, implemented, and tested. It was found that using the apparatus increased the efficiency and the reliability of the gearbox maintenance shop.

المستخلص

من التجربة والخبرة العملية في ورش صيانة وإصلاح الآليات الثقيلة يتم تصنيف بعض الأجزاء القيمة وغالية الثمن فئة (أ) كالمحركات وصناديق التروس ويتم الاحتفاظ بأعداد قليلة منها في المخزون. يعتبر صندوق التروس من أكبر الأجزاء في الآليات الثقيلة وتأتي أهميتها بعد المحرك مباشرة، ومن هنا تبرز أهمية صيانة وإصلاح صناديق التروس بدرجة عالية من الاعتمادية لضمان حياة عملية جيدة للمعدة. وفيما أجهزة فحص المحركات تصلح لفحص مختلف أنواع المحركات بينما صناديق التروس تكون مواصفاتها مقيدة وفقا لنوع الآلية المركب عليها ونوع المحرك ونوع القدرة المنقولة وتعدد السرعات الخارجة من هنا تظهر أهمية إيجاد وسيلة لفحص واختبار أداء صندوق التروس قبل وبعد الصيانة والإصلاح وهناك حاجة لتصميم جهاز اختبار خاص للقيام بالعمليات المطلوبة لتحليل أداء صندوق التروس. التكلفة العالية لاستيراد أجهزة فحص متخصصة لصناديق التروس المعنية أظهرت الحاجة لتصميم جهاز اختبار لصناديق التروس للآليات الثقيلة العاملة ضمن أسطول الشركة. في هذا البحث تم تصميم جهاز اختبار بسيط له المقدرة على فحص صناديق تروس الآليات الثقيلة. تم التصميم والتنفيذ لجهاز الاختبار لمساعدة أفراد الصيانة في تشخيص ومعرفة الأعطال التي تحدث في السرعات لتتم الصيانة باعتمادية عالية. يهدف البحث لتصميم وتنفيذ جهاز فحص بسيط لفحص صندوق التروس لنوع محدد من الآليات الثقيلة، مستخدما موتور كهربائي ذو تيار متردد كبديل للمحرك للمساعدة في أعمال الصيانة لهذا النوع المحدد من الآليات.

Table of Contents

آية قرآنية	i
Dedication	ii
Acknowledgements.....	iii
Abstract	iv
المستخلص	v
Table of Contents	vi
Table of Figures	ix
Chapter 1: Introduction	1
1.1: General introduction:	1
1.2: Gears	3
1.3: Problem statement:.....	1
1.4: Research importance:.....	2
1.5: Research Objectives:.....	2
1.6: Methodology:.....	2
1.7: Research layout:.....	2
Chapter 2: Literature Review and previous studies.....	3
2.1: Gear Classification.....	3
2.1.1: Parallel Gear Shafts –	3
2.1.2: Intersecting Shaft Gears –	4
2.1.3: Neither Parallel nor Intersecting-	4
2.2: Velocity Classification.....	4
2.3: Type of Gears.....	5
2.3.1: Spur Gears	5
2.3.2: Helical Gears	6
2.3.3: Bevel Gears.....	7
2.3.4: Mitter Gears.....	9
2.3.5: Worm Gears.....	10
2.3.6: Racks (Straight Gears).....	12

2.3.7: Herringbone Gears.....	13
2.3.8: Hypoid Gears	14
2.3.9: Internal Gear	15
2.4: Gear Trains.....	16
2.5: Types of Gearboxes:	20
2.5.1: Planetary gearbox	20
2.5.2: Harmonic gearbox	21
2.5.3: Cycloid gearbox.....	22
2.6: Evolution of Gearbox Testing.....	23
2.7: Gearbox Performance Measurement principle	25
2.7.1: Hilbert Method: Using the vibration signal:	26
2.7.2: Using an energy efficiency measurement test bench:	27
2.7.3: Calorimetric method [6]	29
2.7.4: Using noise emission:.....	30
2.8: Electrical Motors.....	16
2.8.1: Classification of A.C. Motors.....	Error! Bookmark not defined.
Chapter 3: Methodology	34
3.1: Introduction:.....	34
3.2: The gearbox design concepts:.....	34
3.3: Gear ratios and speed calculations:.....	35
3.3.1: Speed Ratios	35
3.3.2: The rotation speed	36
3.4: Design Steps:	39
3.4.1: The moment of inertia of the gearbox.....	39
3.4.2: The torque of the speed changing gearbox (Tg).....	41
3.4.3: The power of the electrical motor (Pm).....	42
3.4.4: Connecting shaft Diameter (D)	42
3.4.5: Selecting the size and type of the belt.	43
3.5: The Final Test Rig	45
Chapter 4: Results	48

4.1: Measured speeds:	48
4.2: Calculated Speeds:	49
Chapter 5: Conclusion and recommendation.....	50
5.1: Conclusion:	50
5.2: Recommendations:.....	50
References	51

Table of Figures

Figure 2-1: Gear Categories according to axis position	4
Figure 2-2: Spur Gears.....	6
Figure 2-3: Helical Gear	7
Figure 2-4: Bevel Gear	9
Figure 2-5: Mitter Gear.....	10
Figure 2-6: Worm Gear.....	12
Figure 2-7: Rack and Pinion	13
Figure 2-8: Herring Bone Gear.....	14
Figure 2-9: Hypoid Gear.....	14
Figure 2-10: Internal Gear	16
Figure 2-11: the dependency of direction and velocity of the output.....	19
Figure 2-12: Conventional gears	20
Figure 2-13: A planetary gearbox.....	20
Figure 2-14: Construction and operation of an HDC harmonic gearbox	22
Figure 2-15: A schematic diagram of a cycloid speed reducer	23
Figure 2-16: Evolution of Gearbox Testing.....	24
Figure 2-17: back-to-back arrangement.....	24
Figure 2-18: Measurement Principle Gearbox test bench	26
Figure 2-19: FZG Back-to-back test rig with add-ons for efficiency tests	28
Figure 2-20: Typical gearbox losses.....	28
Figure 2-21: Back-to-back test bench complete gearbox	29
Figure 2-22: back-to-back electrical Testing.....	30
Figure 2-23: Back-to-back electrical Testing with reducer	30
Figure 2-24: Gearbox Test Rig	31
Figure 2-25: schematic representation of the gearbox test rig	31
Figure 2-26: Mechanical power-recirculation type test rig	32
Figure 2-27: gearbox.....	33
Figure 2-28: Squirrel Cage AC motor	17
Figure 3-1: Schematic diagram for the heavy vehicle gearbox.....	35
Figure 3-2: the Neutral Position.....	37
Figure 3-3: The Gearbox 1st speed.....	37
Figure 3-4: The Gearbox 4th speed	38
Figure 3-5: The Gearbox Reverse speed	38
Figure 3-6: The moment of Inertia	39
Figure 3-7: CAD Drawing for the vehicle gearbox.....	40
Figure 3-8: Solid Work mass Properties.....	41
Figure 3-9: loads on the shaft	42
Figure 3-10: heavy vehicles gearbox testing rig.....	47

Figure 3-11: Block Diagram of the Final Test rig46
Figure 4-1: Digital Tachometer48

Chapter 1

Introduction

1.1: General introduction:

The experience of people working in heavy machinery maintenance workshops in the maintenance of different types of vehicles showed that some large spare parts such as engines and gearboxes (classified as type A) are very expensive and so small numbers of them are kept as inventory. The gearbox is the second largest part in the heavy machinery after the engine and has the second priority after the engine. Therefore, it is very vital to maintain gearboxes with a high degree of reliability to insure a good service record.

Every vehicle consists of a power Source and a power Transmission system, which provides a controlled application of the Power.

Transmission is an assembly of parts including the speed changing gears and the propeller shaft by which the power is transmitted from an engine to a live axle.

often transmissions refers simply to the gear box that uses gears and gear trains to provide speed and torque conversions from a rotating power source to another device.

Power transmitted by Gear boxes were fluctuating strongly in many of the applications. For example, in automobiles, based on the condition of driving, torque and speed varies. In machining operations, based on the material to be machined,

Torque and speed varies. These evidences show that, test rigs are needed for testing such gearboxes. Performance of gears depends on parameters like its design, material, manufacturing, and working environment. Developing mathematical model to predict the life of gear will be difficult because of interaction between these parameters.

1.2: Problem statement:

Through the experience of people working in heavy machinery maintenance workshops in the maintenance of different types of vehicles, the large spare parts as the engine and gearbox are classified as type A and are very expensive and a small number are kept as inventory.

During repairing and troubleshooting gearboxes, a way to check and inspect its performance before and after repairs needed. There are testing devices build for gearboxes of other vehicles that can be brought from abroad but are very expensive; therefore the need to design a device or apparatus for testing the gearboxes used in the working vehicles in the fleet of the company is raised.

1.3: Research importance:

Includes the following:

- Inspection of the transmission gearbox after repair outside the vehicle.
- Reducing the time and efforts of maintenance and repair.
- increasing the quality of the maintenance work done.

1.4: Research Objectives:

1. Design a test rig to test the speeds of heavy vehicles gearboxes.
2. Implementation of the test rig system.

1.5: Methodology:

The solving of this problem will be done by:

1. Theoretical study of the gearbox testing.
2. Design of the Transmission System Test device
3. Design Implementation.

1.6: Research layout:

This dissertation consists of five chapters, chapter One reflects the research out lines, chapter Two gives the literature review and previous studies, chapter Three presents the methodology, chapter Four show the result discussion, and final chapter five conclusion and recommendation

Chapter 2

Literature Review and previous studies

2.1: Gears

Gears are mechanical elements, which are used for transmitting a synchronous motion directly between shafts; these may be parallel or at any skew axis. Gears are the most durable and rugged of all mechanical drives and can be used for transmitting high power with high efficiency (up to 99% in the case of parallel shafts).

The design of meshing gears is complex especially if an optimum solution is required in an application.

British, American and ISO standards describe analytical techniques in much detail but they tend to be rather daunting to the inexperienced and infrequent gear designer. Manufacturers' catalogues, in contrast, often do not give adequate design information to enable a thorough verifying analysis to be performed on the gears they produce.

Frequently a simplified analytical selection procedure is given but for a more comprehensive explanation, it is necessary to refer to the appropriate standard for details.[1]

2.2: Gear Classification

Gears may be classified according to the relative position of the axes of revolution.[1] The axes may be

- a) Parallel,
- b) Intersecting or
- c) Non-parallel and non-intersecting.

2.2.1: Parallel Gear Shafts –

The gears that have parallel shafts are spur gears, helical gears, and herringbone gears.

Some gears mesh in the same plane. They are used for transmission of rotary motion between parallel shafts. They offer maximum transmission of power and high efficiency.

They are used in higher horsepower applications where long-term operational efficiency is more important. They are more expensive to manufacture and create axial thrust. They have higher load capacity and make less noise. They are generally used in clocks, movie projector, and car steering. They are widely used for manual transmission.

2.2.2: Intersecting Shaft Gears –

The gears that have intersecting shaft are bevel gears, straight bevel gears, zero bevel gears and spiral gears. These gears are designed for the efficient transmission of power and motion between intersecting shafts at an angle. These are ideal for applications requiring high load capacity and are cheaper than the parallel shaft gears. They are used where speed and strength are desirable along with the change in angle of power flow. These gears are widely used in hand drill, locomotives, automobiles, marine applications and all rotorcraft drive system.

2.2.3: Neither Parallel nor Intersecting-

The gears that have neither parallel nor intersecting shafts are hypoid gears, crossed helical gears, and worm gears. These gears provide an effective answer for power transmission applications requiring high-ratio speed reduction in a limited space using non-intersecting shafts. These are ideal for applications requiring only limited load capacity. Lowering ratios easily increases their efficiency. These gears are the cheapest of all gears and are widely used in automobile differentials, electric mixer, speedometer, sprinkler, machine tools, and packaging machinery. Figure 2-1 highlights the gear categories:

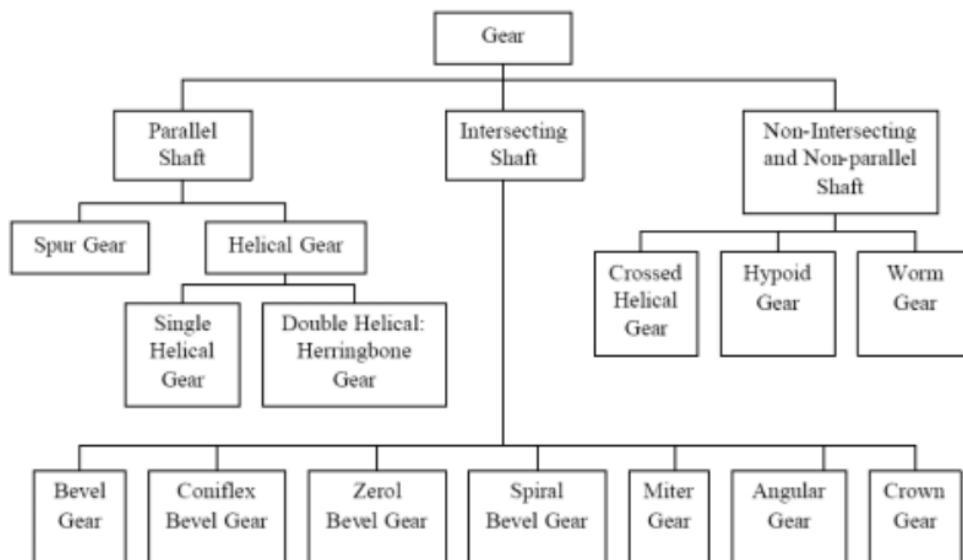

Figure 0-1: Gear Categories according to axis position

2.3: Velocity Classification

Gears are further classified according to velocities.

1) Gears are considered low velocity type, if their peripheral velocity lies in the range of 1 to 3 m/sec

2) Gears are considered medium velocity type, if their peripheral velocity lies in the range of 3 to 15 m/sec

3) Gears are considered high velocity type, if their peripheral velocity exceeds 15 m/sec

2.4: Type of Gears

Various types of gears commonly used are described below:

2.4.1: Spur Gears

Spur gears connect parallel shafts; they are used when shaft rotates in the same plane. These have involutes teeth that are parallel to the shaft and can have internal or external teeth. Spur gears are by far the most commonly used gear type commonly available, and are generally the least expensive and have the following characteristics.

a) The speed and change of the force depends on the gear ratio, the ratio of number of teeth on the gears that are to be meshed.

b) They have higher contact ratio that makes them smooth and quiet in operation.

c) They are available for corrosion resistant operation and can be used to create large gear reductions.

d) They cause no external thrust between gears. They give lower but satisfactory performance.

Spur gears are easy to find, inexpensive, and efficient. They Generally used in simple machines like washing machines, clothes dryer or power winches. They are also used in construction equipment, machine tools, indexing equipment, multi spindle drives, roller feeds, and conveyors.

Limitations:

a) Spur gears generally cannot be used when a direction change between the two shafts is required.

b) They are not used in certain applications such as automobiles because they produce sound when the teeth of both the gears collide with each other. It also increases stress on the gear teeth.

The basic descriptive geometry for a spur gear is shown in the Figure 2-2.

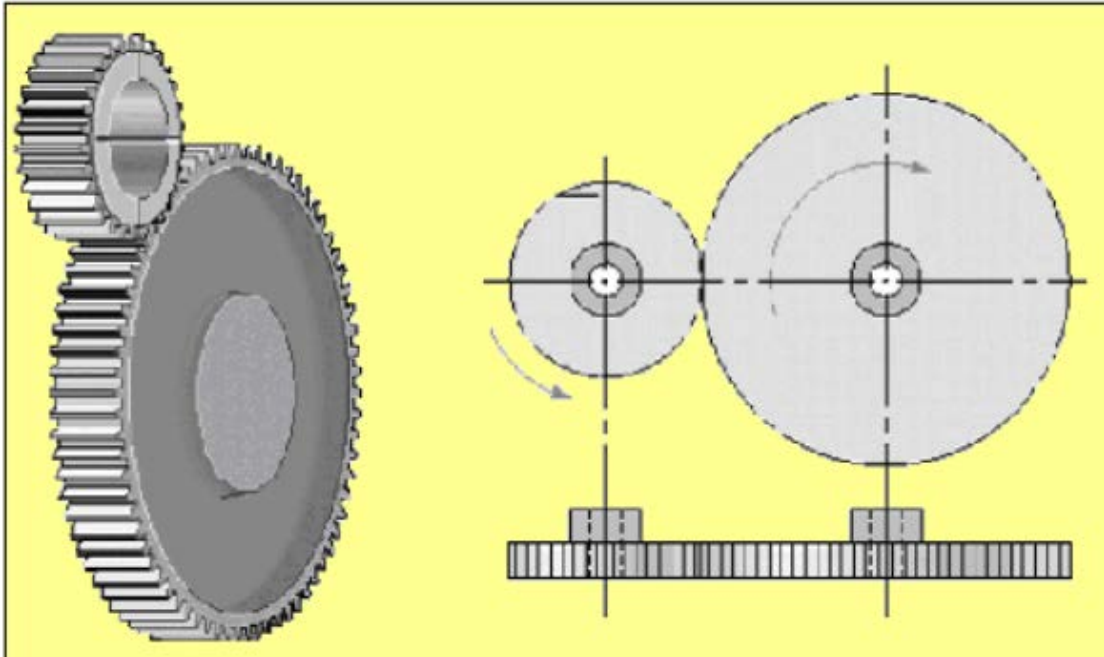

Figure 0-2: Spur Gears

2.4.2: Helical Gears

Helical gears are similar to the spur gear except that the teeth are at an angle to the shaft, rather than parallel to it as in a spur gear. The resulting teeth are longer than the teeth on a spur gear of equivalent pitch diameter. The longer teeth cause helical gears to have the following differences from spur gears of the same size.

2.4.2.1: Characteristics

- a) The basic descriptive geometry for a helical gear is essentially the same as that of the spur gear, except that the helix angle must be added as a parameter.
- b) The helical teeth result in a greater tooth width which enables increased load and power transmissibility for a given gear size. In addition, they result in a smoother engagement and so are less noisy in operation than straight spur gears.
- c) Helical gears may be used to mesh two shafts that are not parallel, although they are still primarily used in parallel shaft applications.
- d) Tooth strength is greater because the teeth are longer. Greater surface contact on the teeth allows a helical gear to carry more load than a spur gear but the longer surface of contact also reduces the efficiency of a helical gear relative to a spur gear.
- e) A special application in which helical gears are used is a crossed gear mesh, in which the two shafts are perpendicular to each other.

2.4.2.2: Applications:

- a) Helical gears used on non-parallel and even perpendicular shafts, and can carry higher loads than can spur gears.
- b) These are highly used in power transmission because they are quieter even at higher speed and are durable. The other possible applications of helical gears are in textile industry, blowers, feeders, rubber and plastic industry, and millers, screen, sugar industry, rolling mills, food industry, elevators, conveyors, cutters, clay working machinery, compressors, cane knives, and in oil industry.

2.4.2.3: Disadvantage:

- a) A disadvantage of helical gear is the resultant thrust along the axis of the gear, which needs to be accommodated by appropriate thrust bearings. This can be overcome by the use of double helical gears having teeth with a 'v' shape.
- b) These are expensive compared to spur gears and much more difficult to find.

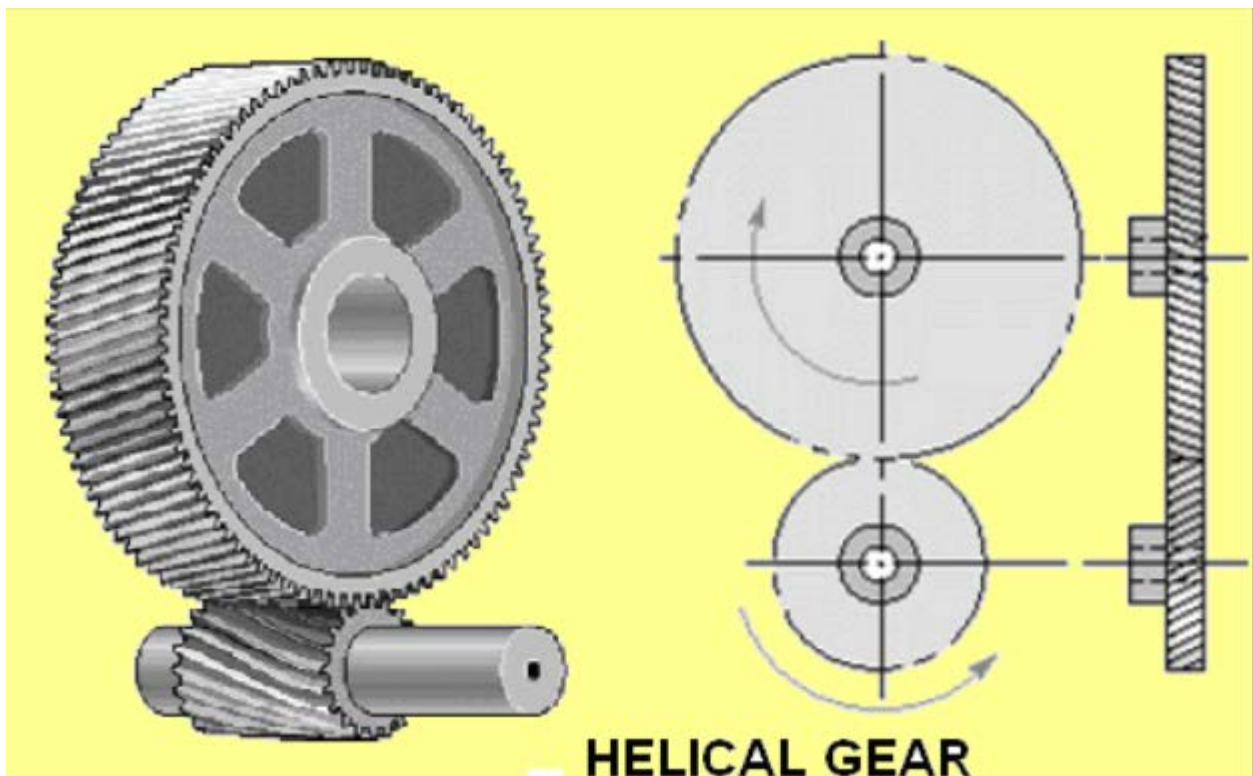

Figure 0-3: Helical Gear

2.4.3: Bevel Gears

Bevel gears (Figure 2-4) are primarily used to transfer power between intersecting shafts and are useful when the direction of a shaft's rotation needs to be changed.

2.4.3.1: Characteristics:

- a) The teeth of bevel gears are formed on a cone surface.
- c) These gears permit minor adjustment during assembly and allow for some displacement due to deflection under operating loads without concentrating the load on the end of the tooth.

2.4.3.2: Types:

Bevel gears come in several types. The teeth on bevel gears can be straight, spiral or bevel.

- a) Standard bevel gears have teeth, which are cut straight and are all-parallel to the line pointing the apex of the cone on which the teeth are based. In straight bevel gears, teeth have no helix angles. In straight when each tooth engages, it affects the corresponding tooth and simply curving the gear teeth can solve the problem. Straight tool bevel gears are generally considered the best choice for systems with speeds lower than 1000 feet per minute: they commonly become noisy above this point.
- b) Spiral bevel gears are also available which have teeth that form arcs, which gives performance improvements. The contact between the teeth starts at one end of the gear and then spreads across the whole tooth.
- c) Hypocycloid bevel gears are a special type of spiral gear that will allow nonintersecting, non-parallel shafts to mesh. The hypoid bevel gears can engage with the axes in different planes. This is used in many car differentials. The ring gear of the differential and the input pinion gear are both hypoid. This allows input pinion to be mounted lower than the axis of the ring gear. Hypoid gears are stronger, operate more quietly, and can be used for higher reduction ratios. They also have sliding action along the teeth, potentially reducing efficiency.

2.4.3.3: Applications:

- a) Excellent choice for intersecting shaft systems. A good example of bevel gears is seen as the main mechanism for a hand drill. As the handle of the drill is turned in a vertical direction, the bevel gears change the rotation of the chuck to a horizontal rotation. The bevel gears in a hand drill have the added advantage of increasing the speed of rotation of the chuck and this makes it possible to drill a range of materials.
- b) The bevel gears find its application in locomotives, marine applications, automobiles, printing presses, cooling towers, power plants, steel plants and in on all current rotorcraft drive system.
- c) Spiral bevel gears are important components on all current rotorcraft drive systems. These components are required to operate at high

speeds, high loads, and for an extremely large number of load cycles. In this application, spiral bevel gears are used to redirect the shaft from the horizontal gas turbine engine to the vertical rotor.

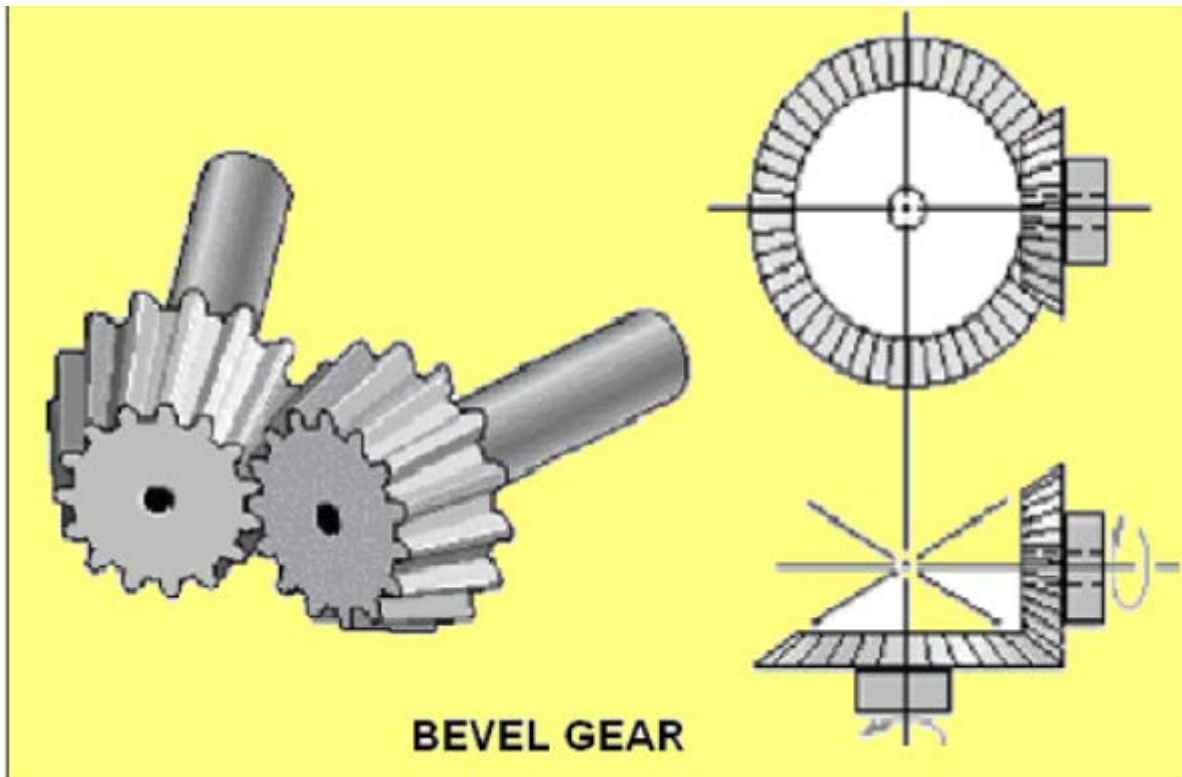

Figure 0-4: Bevel Gear

2.4.4: Mitter Gears

Miter gears (Figure 2-5) are bevel gears put together with equal numbers of teeth and axes that are usually at right angles. Miter is the surface forming the beveled end or edge of a piece, where a miter joint is made.

- a) They are designed for the efficient transmission of power and motion between intersecting shafts at right angles.
- b) They are known for efficient power transfer and durability.
- c) They give smoother, quieter operation.
- d) They handle higher speeds and greater torque loads.
- e) They provide a steady ratio.
- f) They are used as important parts of conveyors, elevators, and kilns.



Figure 0-5: Mitter Gear

2.4.5: Worm Gears

Worm gears (Figure 2-6) are special gears that resemble screws, and can be used to drive spur gears or helical gears.

Worm gears, like helical gears, allow two non-intersecting 'skew' shafts to mesh. Normally, the two shafts are at right angles to each other but not in the common plane. A worm gear is equivalent to a V-type screw thread. Another way of looking at a worm gear is that it is a helical gear with a very high helix angle.

2.4.5.1: Characteristics:

- a) One very important feature of worm gear meshes is their irreversibility i.e. when a worm gear is turned, the meshing spur gear will turn, but turning the spur gear will not turn the worm gear. The resulting mesh is 'self-locking', and is useful in ratcheting mechanisms. The gear cannot turn the worm because the angle on the worm is shallow and when the gear tries to spin the worm, the friction between the two holds the worm in place.
- b) Worm gear is always used as the input gear. For the operation of worm gear, torque is applied to the input end of the worm shaft by a driven sprocket or electric motor. The worm and the worm shaft are supported by anti-friction roller bearings.
- c) Worm gears are normally used when a high gear ratio is desired.

2.4.5.2: Advantages:

- a) It tolerates large loads and high-speed ratios. These are used when high-speed reduction more than 10:1 is required.
- b) Meshes are self-locking (which can be either an advantage or a disadvantage).
- c) Worm gears can provide a high angular velocity between non-intersecting shafts at right angles. They are capable of transmitting high tooth loads.
- d) Worm gears are used when large gear reductions are required. Worm gear has a unique property of easily turning the gear.
- e) They offer smoothest, quietest form of gearing. They provide high-ratio speed reduction in minimal spaces.

2.4.5.3: Types:

There are three types of worm gears:

- a) Non-throated- a helical gear with a straight worm. Tooth contact is a single moving point on the worm drive.
- b) Single throated- has concave helical teeth wrap around the worm. This leads to line contact.
- c) Double throated- called a cone or hourglass. It has concave teeth both on the worm and helical gear

2.4.5.4: Limitations:

- a) The only disadvantage of worm gear is the high sliding velocities across the teeth, which results in high friction losses. Because of high friction, worm gears are very inefficient.
- b) When used in high torque applications, the friction causes the wear on the gear teeth and erosion of restraining surface.

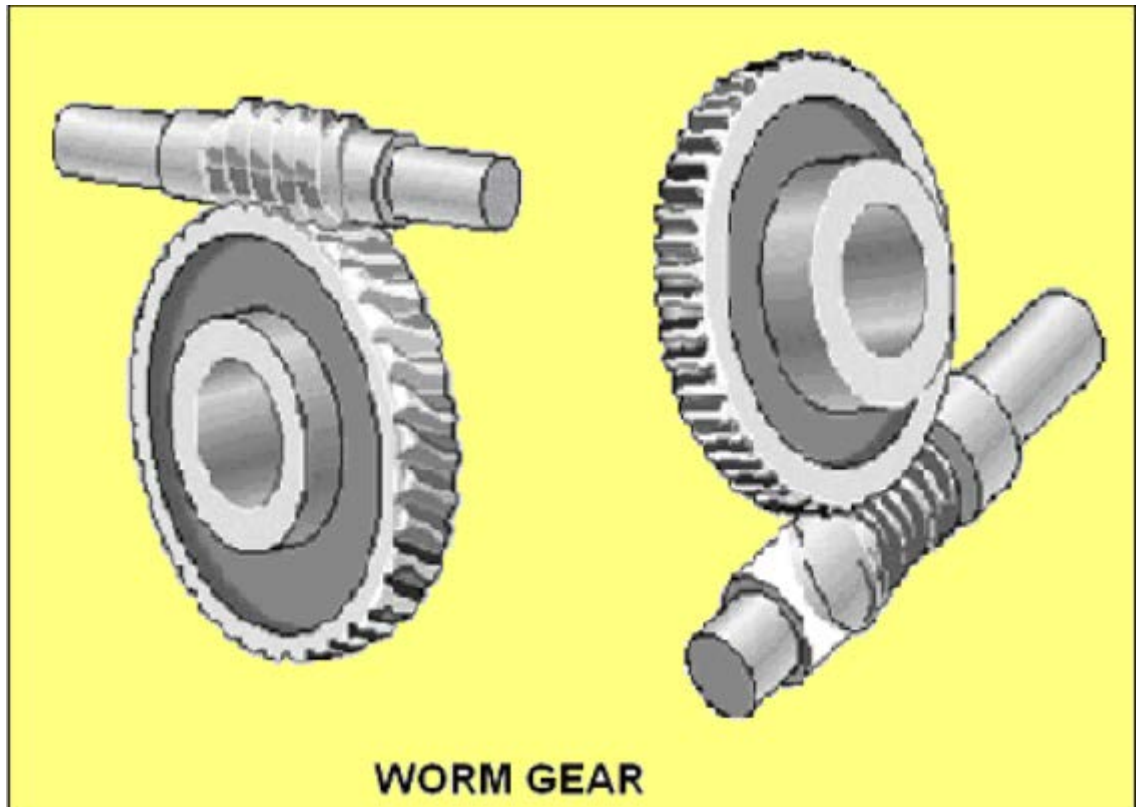

Figure 0-6: Worm Gear

2.4.6: Racks (Straight Gears)

A rack is usually a gear without curvature (i.e. of infinite diameter) and when used with a meshing pinion as shown on Figure 2-7 enables rotary to linear movement or vice versa.

- a) They will mesh with pinions of the same pitch.
- b) This is the only gearing mechanism that converts rotational motion to translational motion. Racks are made of various materials. The commonly used materials for racks are stainless steel, brass, and plastic.

2.4.6.1: Applications:

- a) Efficiently transmits power. Generally offers better precision than other conversion methods.
- b) Perhaps the most well-known application of a rack is the rack and pinion steering system used on many cars in the past. The steering wheel of a car rotates the gear that engages the rack. The rack slides right or left, when the gear turns, depending on the way we turn the wheel. Windshield wipers in cars are powered by a rack and pinion mechanism. They are also used in some scales to turn the dial that displays weight.

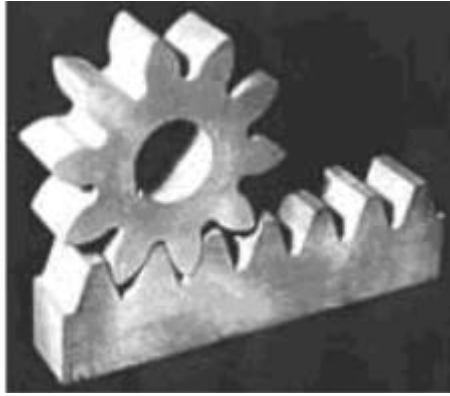

Figure 0-7: Rack and Pinion

2.4.7: Herringbone Gears

In the case of spur gears, the tooth forces act only normal to the gear axis, whereas in case of helical gears, an additional component of force also acts along the gear axis. Its effect, however, can be eliminated by using two gears of opposite helix together or a gear may be fabricated such that half of its width is cut with helix in one direction and the other half of the teeth are cut in the opposite direction. Such a gear is called the Herringbone gear (Figure 2-8).

- a) They conduct power and motion between non-intersecting, parallel axis that may or may not have center groove with each group making two opposite helices. Action is equal in force and friction on both gears and all bearings.
- b) The most common application is in heavy machinery and power transmission. They utilize curved teeth for efficient, high capacity power transmission. This offers reduced pulsation due to which they are highly used for extrusion and polymerization.



Figure 0-8: Herring Bone Gear

2.4.8: Hypoid Gears

One of a number of gear types for offset shafts (Figure 2-9)



Figure 0-9: Hypoid Gear

2.4.9: Internal Gear

Internal gears are hollow with teeth cut into the inside of the rim as shown on Figure 2-10 while the outside diameter is smooth. Gears make an internal contact with these gears.

The properties and teeth shape is similar as of external gears except that the internal gear had different addendum and duodenum values modified to prevent interference in internal meshes.

2.4.9.1: Characteristics:

- b) The meshing arrangement enables a greater load carrying capacity with improved safety (since meshing teeth are enclosed) compared to equivalent external gears.
- c) Shaft axes remain parallel and enable a compact reduction with rotation in the same sense. Internal gears are not widely available as standard.
- d) Internal gear offers low sliding and high stress loading. They are used in planetary gears to produce large reduction ratios.
- e) When they are used with the pinion, more teeth carry the load that is evenly distributed. The even distribution decreases the pressure intensity and increases the life of the gear.
- f) Allows compact design since the center distance is less than for external gears.
- g) A high contact ratio is possible.
- h) It provides good surface endurance due to a convex profile surface working against a concave surface.

2.4.9.2: Disadvantages:

- a) Housing and bearing supports are more complicated, because the external gear nests within the internal gear.
- b) Low ratios are unsuitable and in many cases impossible because of interferences.
- c) Fabrication is limited to the shaper generating process, and usually special tooling is required.



Figure 0-10: Internal Gear

2.5: Electrical Motors

With the almost universal adoption of A.C. system of distribution of electric energy for light and power, the field of application of A.C. motors has widened considerably during recent years. As a result, motor manufactures have tried, over the last few decades, to perfect various types of A.C. motors suitable for all classes of industrial drives and for both single and three-phase A.C. supply. This has given rise to bewildering multiplicity of types whose proper classification often offers considerable difficulty. Different A. C. motors may however, be classified and divided into various groups from the following different points of view:

1. As Regards Their Principle Of Operation

(A) Synchronous motors

- (I) Plain and (ii) super

(B) Asynchronous motors

(a) Induction motors

- (I) Squirrel cage { single and double }
- (ii) Slip-ring (external resistance)

(b) Commutator motors

- (I) Series { single phase universal
- (ii) Compensated { conductively inductively
- (iii) Shunt { simple compensated
- (iv) Repulsion { straight compensated

- (v) repulsion-start induction
- (vi) Repulsion induction

2. As Regards The Type Of Current

- (i) Single phase
- (ii) Three phase

3. As Regards Their Speed

- (i) Constant speed
- (ii) Variable speed
- (iii) Adjustable speed

4. As Regards Their Structural Features

- (i) Open
- (ii) Enclosed
- (iii) Semi-enclosed
- (iv) Ventilated
- (v) pipe-ventilated
- (vi) Reverted frame eye etc.

34.2. Induction Motor: General Principle

Generally, conversion of electrical power into mechanical power takes place in the rotating part of an electric motor. In D.C. motors, the electric power is conducted directly to the armature (i.e. rotating part) through brushes and commutator (Figure 2-28). Hence, in this sense, a D.C. motor can be called a conduction motor. However, in A.C. motors, the rotor does not receive electric power by conduction but by induction in exactly the same way as the secondary of a 2-winding transformer receives its power from Figure 2-28

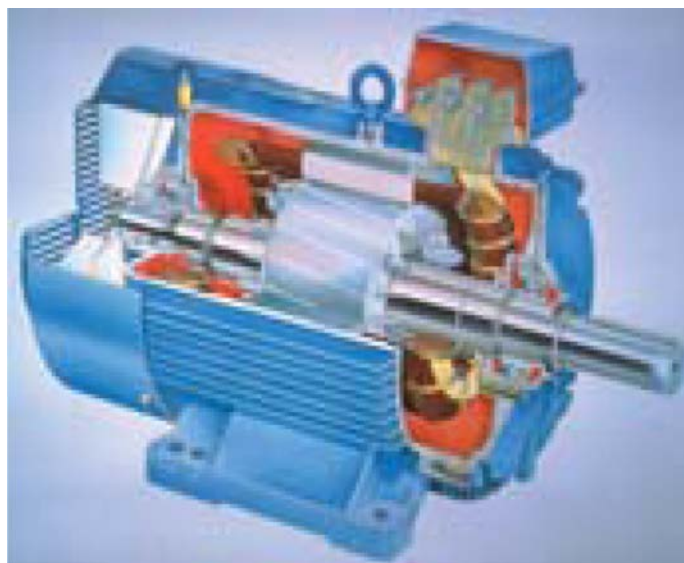

Figure 0-11: Squirrel Cage AC motor

Squirrel cage AC induction motor opened to show the stator and rotor construction, the shaft with bearings, and the cooling fan. Three-phase high voltage asynchronous motors Induction Motor1245 the primary.

That is why such motors are known as induction motors. In fact, an induction motor can be treated as a rotating transformer i.e. one in which primary winding is stationary but the secondary is free to rotate.

Of all the A.C. motors, the poly-phase induction motor is the one, which is extensively used for various kinds of industrial drives. It has the following main advantages and some disadvantages:

Advantages:

1. It has very simple and extremely rugged, almost unbreakable construction (especially squirrel- cage type).
2. Its cost is low and it is very reliable.
3. It has sufficiently high efficiency. In normal running condition no brushes are needed, hence frictional losses are reduced. It has a reasonably good power factor.
4. It requires minimum of maintenance.
5. It starts up from rest, needs no extra starting motor, and has not to be synchronized. Its starting arrangement is simple especially for squirrel-cage type motor.

Disadvantages:

- 1) Its speed cannot be varied without sacrificing some of its efficiency.
- 2) Like a D.C. shunt, motor its speed decreases with increase in load.
- 3) Its starting torque is inferior to that of a D.C. shunt

2.6: Gear Trains

A conventional gear train [1] is made up of two or more gears. There will be a change in the angular velocity and torque between an input and output shaft; the fundamental speed relationship is given by:

$$n = \pm \frac{\omega_i}{\omega_o} = \pm \frac{N_o}{N_i}$$

Where N_i and ω_i are the number of teeth on, and the angular velocity of, the input gear, and N_o and ω_o are the number of teeth on, and the angular velocity of, the output gear. A negative sign is used when two external gears are meshing, Figure 2-11(a), or a positive sign indicates that system where an internal gear is meshing with an internal gear, Figure 2-11(b).

In the case where an idler gear is included, the gear ratio can be calculated in an identical fashion, hence for an external gear train, Figure 2-11(c) and (d),

$$n = \frac{\omega_{in}}{\omega_{out}} = \left(-\frac{N_2}{N_1}\right)\left(-\frac{N_3}{N_2}\right) = \frac{N_3}{N_1}$$

The direction of the output shaft is reversed for an internal gear train, Figure 2-11(d).

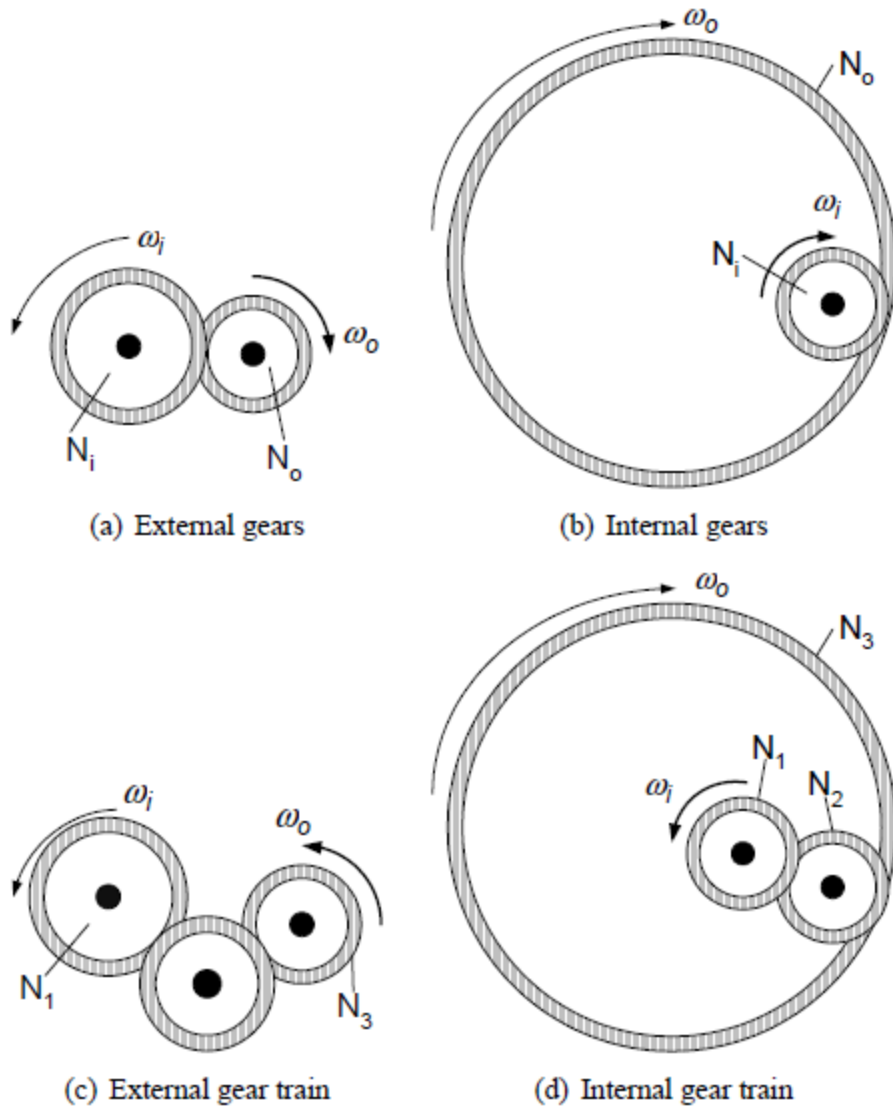

Figure 0-12: the dependency of direction and velocity of the output

In practice, the actual gear train can consist of either a spur, or helical gear wheels.

A spur gear (see Figure 2-12(a)) is normally employed within conventional gear trains, and has the advantage of producing minimal axial forces that reduce problems connected with motion of the gear bearings. Helical gears (see Figure 2-12(b)) are widely used in robotic systems since they give a higher contact ratio than spur gears for the same ratio; the penalty is axial gear load. The limiting factors in gear transmission are the stiffness of the gear teeth, which can be maximized by selecting the largest-diameter gear wheel that is practical for the application, and backlash or lost motion between individual gears. The

net result of these problems is a loss in accuracy through the gear train, which can have an adverse effect on the overall accuracy of a controlled axis.

In many applications conventional gear trains can be replaced by complete gearboxes (in particular those of a planetary, harmonic, or cycloid design) to produce compact drives with high reduction ratios [1].

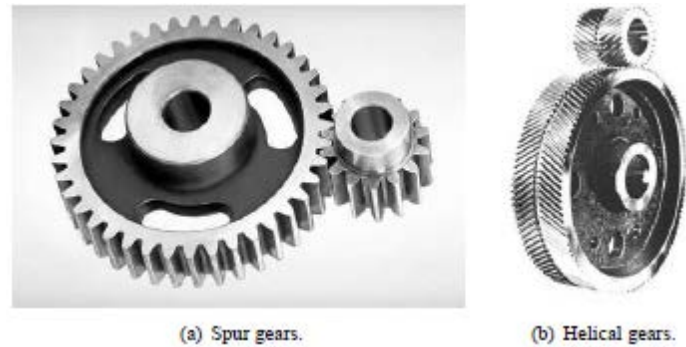

Figure 0-13: Conventional gears

2.7: Types of Gearboxes:

2.7.1: Planetary gearbox

A Planetary gearbox is co-axial and is particularly suitable for high torque, low speed applications. It is extremely price-competitive against other gear systems and offers high efficiency with minimum dimensions. For similar output torques, the planetary gear system is the most compact gearbox on the market. The internal details of a planetary gearbox are shown in Figure 2-13; a typical planetary gearbox consists of the following:

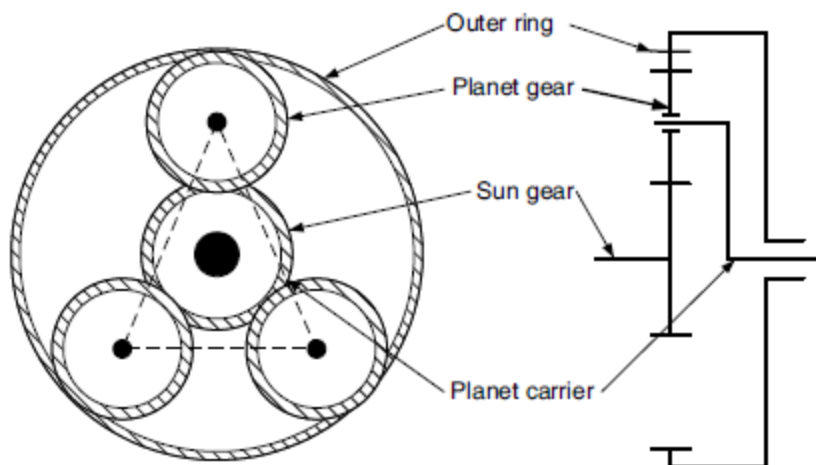

Figure 0-14: A planetary gearbox

- A sun gear, which may or may not be fixed.
- A number of planetary gears.
- Planet gear carrier.

- An internal gear ring, which may not be used on all systems.

This design results in relatively low speeds between the individual gear wheels and this result in a highly efficient design. One particular advantage is that the gearbox has no bending moments generated by the transmitted torque; consequently, the stiffness is considerably higher than in comparable configuration.

In addition, they can be assembled coaxially with the motor, leading to a more compact overall design. The relationship for a planetary gearbox can be shown to be:

$$\frac{\omega_{sun} - \omega_{carrier}}{\omega_{ring} - \omega_{carrier}} = -\frac{N_{ring}}{N_{sun}}$$

Where ω_{sun} , $\omega_{carrier}$ and ω_{ring} are the angular speeds of the sun gear, planet carrier and ring with reference to ground. N_{ring} and N_{sun} are the number of teeth on the sun and ring respectively. Given any two angular velocities, the third can be calculated – normally the ring is fixed hence $\omega_{ring} = \text{zero}$. In addition, it is important to define the direction of rotation; normally clockwise is positive, and counterclockwise is negative.

2.7.2: Harmonic gearbox

A harmonic gearbox will provide a very high gear ratio with minimal backlash within a compact unit. As shown in Figure 2-14(a), a harmonic drive is made up of three main parts: the circular spline, the wave generator, and the flexible flex spline.

The design of these components depends on the type of gearbox; in this example, the flex spline forms a cup. The operation of a harmonic gearbox can be appreciated by considering the circular spline to be fixed, with the teeth of the flex spline to engage on the circular spline. The key to the operation is the difference of two teeth (see Figure 2-14(b)) between the flex spline and the circular spline. The bearings on the elliptical-wave generator support the flex spline, while the wave generator causes it to flex. Only a small percentage of the flex spline's teeth are engaged at the ends of the oval shape assumed by the flex spline while it is rotating, so there is freedom for the flex spline to rotate by the equivalent of two teeth relative to the circular spline during rotation of the wave generator. Because of the large number of teeth that are in mesh at any one time, harmonic drives have a high torque capability; in addition, the backlash is very small, being typically less than 30" of arc.

In practice, any two of the three components that make up the gearbox can be used as the input to, and the output from, the gearbox, giving the designer considerable flexibility. The robotic hand shown in Figure incorporates three harmonic gearboxes of a pancake design where the flex spline is a cylinder equal in width to the wave generator.

(a) Components of a harmonic gearbox

(b) Operation of a harmonic gearbox, for each 360° rotation of the wave generator the flexspline moves two teeth. The deflection of the flexspline has been exaggerated.

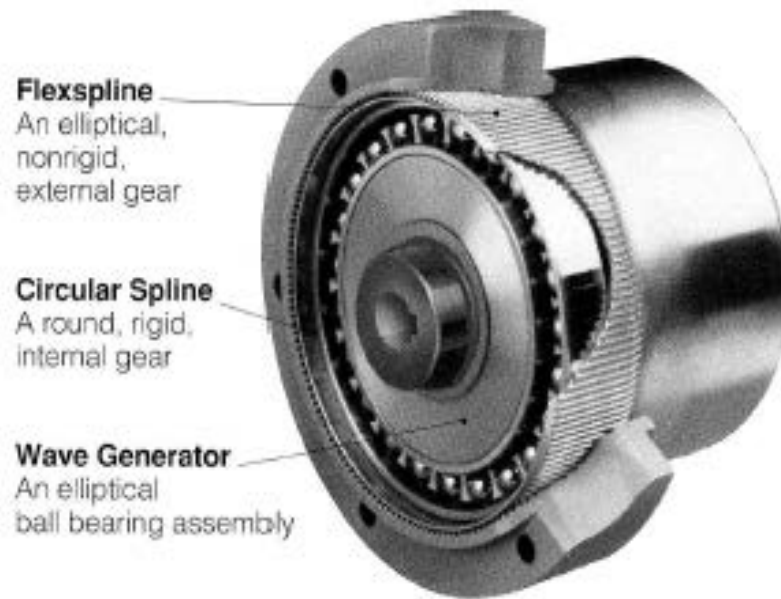

(a) Components of a harmonic gearbox

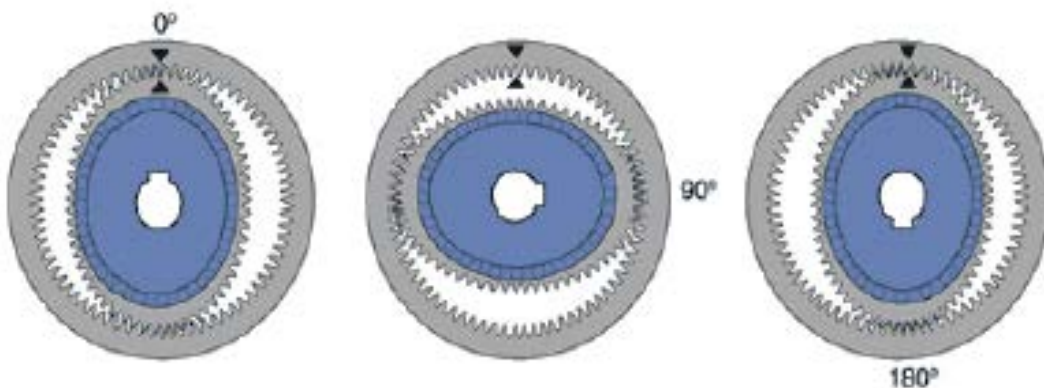

(b) Operation of a harmonic gear box, for each 360° rotation of the wave generator the flexspline moves 2 teeth. The deflection of the flexspline has been exaggerated.

Figure 0-15: Construction and operation of an HDC harmonic gearbox

It should be noted that in the diagram only one cycloid disc is shown, commercial systems typically have a number of discs, to improve power handling.

2.7.3: Cycloid gearbox

The cycloid gearbox is of a co-axial design and offers high reduction ratios in a single stage, and is noted for its high stiffness and low backlash. The gearbox is suitable for heavy-duty applications, since it has a very high shock load capability of up to 500%. Commercially cycloid gearboxes are available in a range of sizes with ratios between 6:1 and 120:1 and with a power transmission capability of up to approximately 100 kW. The gearbox design,

which is both highly reliable and efficient, undertakes the speed conversion by using rolling actions, with the power being transmitted by cycloid discs driven by an eccentric bearing.

The significant features of this type of gearbox are shown in Figure 2-15. The gearbox consists of four main components:

- A high-speed shaft with an eccentric bearing.
- Cycloid disc(s).
- Ring gear housing with pins and rollers.
- Slow speed shaft with pins and rollers.

As the eccentric rotates, it rolls the cycloid disc around the inner circumference of the ring gear housing. The resultant action is similar to that of a disc

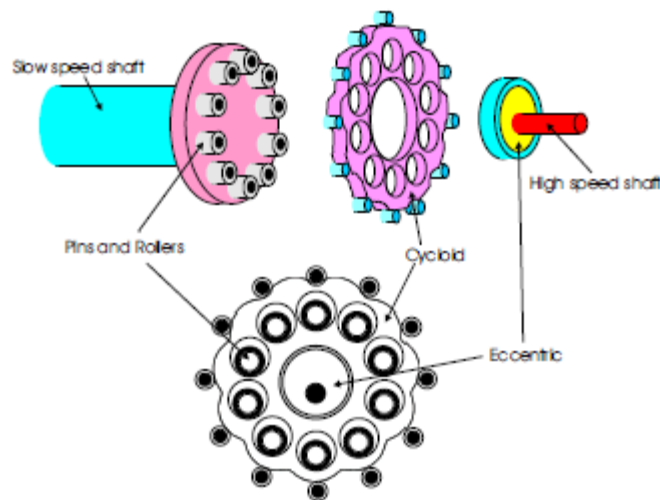

Figure 0-16: A schematic diagram of a cycloid speed reducer

2.8: Evolution of Gearbox Testing

As described by Horacio Bulacio [2] gearbox performance testing is rather a new field in mechanical power discipline, Figure 2-16 shows the technological steps of gearbox testing.

Steps on the way:-

- 1) VESTAS introduced "accelerated endurance tests" in 1999/2000 by back to back arrangement Figure 2-17 [2]

Gears are designed for "infinite life" with a certain safety-factor.

The safety factor is supposed to account for:

- Uncertainties in loads and operation conditions
- Uncertainties in the design- and calculation-methods
- Material variation
- manufacturing variation

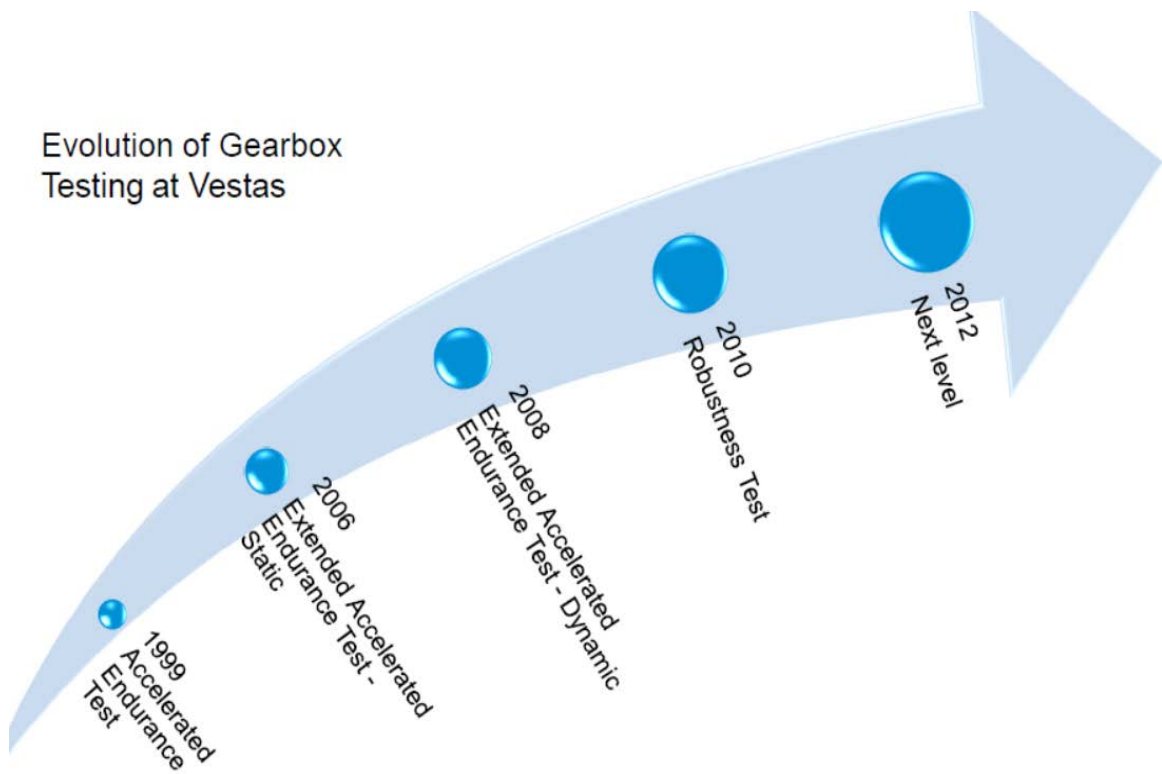

Figure 0-17: Evolution of Gearbox Testing

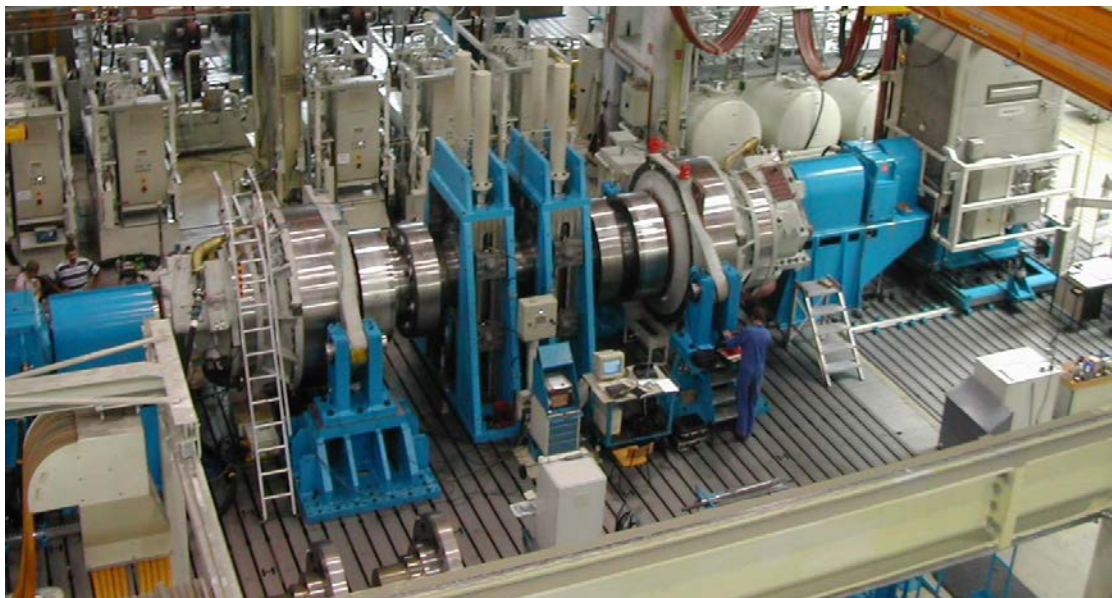

Figure 0-18: back-to-back arrangement

2) Robustness Test

3 Gearbox Test Rigs

Power 6 - 8MW

Torque 4-5MNm (18MNm)

Max Speed (LS) 200% nominal

6° angle
Tilt moment
Yaw moment
Thrust load
Hub weight Load
Side load

2.9: Gearbox Performance Measurement principle

The aim is to conduct steady state measurements, i.e. Constant speed and constant load torque. The loading of the gearbox is realized by means of the reducer gearbox via an induction machine with regenerative VSD in field oriented torque control ODE and speed feedback.

The drive side VSD, also with speed feedback, drives the gearbox at desired speed.

By connecting both VSD's via DC-bus, as shown in Figure 2-18 the energy flows from generator to drive side and only the losses of the system have to be added from the grid. The direct method is used to determine the overall efficiency. It requires accurate measurement of the mechanical in-and output power. The torque is measured by means of dedicated 'dual range' torque sensors with an accuracy of 0.1% full scale. At input side the torque range is 10Nm/100Nm and at output 100Nm/1000Nm. The speed is measured using an incremental encoder of 1024 pulses/rev. at input side and at output side, a 360 pulses/rev. encoder embedded in the torque sensor. The ambient and gearbox temperature are measured and logged with calibrated thermocouples type K. In addition, the temperatures of the torque sensors are logged.

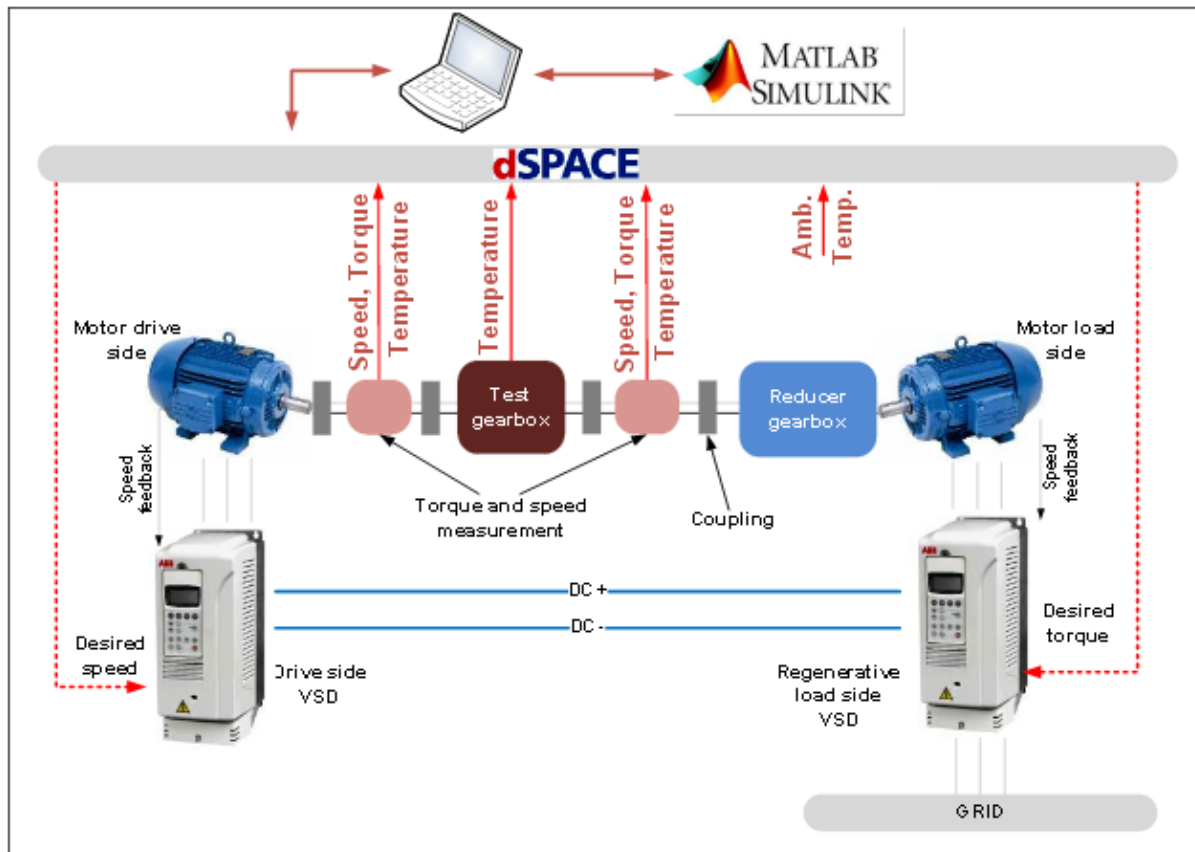

Figure 0-19: Measurement Principle Gearbox test bench

There are a number of previous researches in the topic of gearbox test rigs design and implementation as:

2.9.1: Hilbert Method: Using the vibration signal:

As stated by Rostami[3] gearbox testing can be done by using the vibration signal. Detection of gearbox faults using vibration signals is based on Hilbert method. Tests are done for recording signals of the transmission's gear instates normal and faulty and different periods and loads, by a powerful device called Vibro-test 60. The device recorded signals in frequency-amplitude diagram by FFT method. For using Hilbert method had to convert frequency-amplitude diagrams to frequency-time diagrams beside for get to the parameters time domain, signals are filtered, so they are extracted from the original signal. Thus the remaining signals and subtracted the corresponding definition of the middle band are extracted from the original signal. It is extracted after obtaining the spectrum signal using FFT in MATLAB software-defined frequency spectrum, the signal is removed and then centuries of the use of IFFT signals are obtained when it is desired then the Hilbert method is used.[3]

In bearing fault detection, FFT technique is less efficient for Inner Race (IR) defects, which emit much attenuated vibration signals during incipient stage of fault as they have a greater number of transfer segments.

Another disadvantage of these techniques is that they analyze energy distribution with respect to either time or frequency. Under such constraints, order tracking, adaptive filtering and time–frequency analysis methods play an important role. Bearing rotor systems have a number of factors like load, friction/rubbing, uneven clearances, non-linear stiffness terms, etc. that lead to non-linearity. Signals with such non-linearity are best analyzed in time–frequency domain where along with frequency content, time information is also retained. The failures of rotating machineries can be lead to machinery damage, production losses and personnel injury. Therefore, a very important duty of the maintenance department is to prevent these failures when they are in its initial stage.

The predictive maintenance by vibration analysis is the best tool for this purpose. The vibration analysis is a technique, which is being used to track machine operating conditions and trend deteriorations in order to reduce maintenance costs and downtime simultaneously.

There are many studies on the vibration monitoring of the rotating machinery. Great amount of them concentrate on ball or cylindrical element bearing vibration monitoring.

Monitored vibration of motor-generator system supported by ball and cylindrical roller bearings to predict impending bearing failures can successfully identified impending failures of the bearing outer and inner races.

Al-Najjar [4] observed many bearing vibrations in paper mills for many years to predict remaining bearing life accurately.

He also investigated effectiveness of vibration-based maintenance and proposed some findings. In this study, the application of vibration monitoring and analysis was carried out on PAYKAN's gearbox. Firstly, vibration signals are collected by means of the vibration analyzer equipped with a sensor in the time domain. then, these signals are converted into frequency domain by processing FFT, and the information gained from the vibration signals could be used to predict catastrophic failures, to reduce forced outages, to maximize utilization of available assets, to increase the life of machinery, and to reduce maintenance costs related to health of machinery.

2.9.2: Using an energy efficiency measurement test bench:

Represented by the work of defreyne [5]. The purpose of the test bench is to measure gearbox efficiency at different loads and speeds within the allowed working area of the gearbox. Industrial gearboxes come in various types and power ranges. With the gearbox test bench, it is possible to test a large scope of these types for a power range until 15kW.

Test benches for tests on gear sets are common. In such cases it is just one gear wheel pair that is being tested (Wear, load capacity, oil level, seal friction and efficiency are subjects which can be tested with these test rigs as illustrated in Figure 2-19.

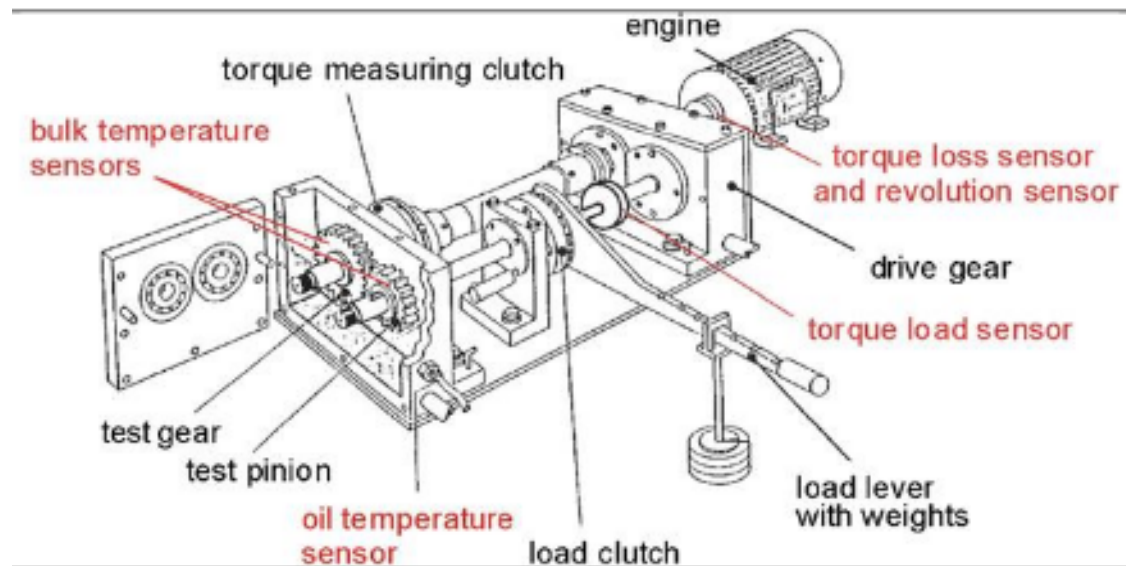

Figure 0-20: FZG Back-to-back test rig with add-ons for efficiency tests

An industrial gearbox however usually contains more than one gear wheel pair.

As can be seen in Figure 2-20, the typical gearbox losses are located at some specific locations includes: Seal losses, Gear losses, churning losses, bearing losses



Figure 0-21: Typical gearbox losses

The gears are fixed in their right position by means of bearings, which have friction losses. While transmitting power, losses occur in the gear pairs as gear losses. The lubrication oil is transported via the gears, which result in churning losses. To prevent the oil from leaking out of the gearbox, seals are implemented and they result in some friction losses. To measure the efficiency of a complete gearbox a few different principles can be applied. Back – to –

back mechanical an equal setup as inFigure 2-21 could be used to test a complete gearbox. To do so, two identical gearboxes with same ratio should be connected to each other at the input axes and respectively at output axes.

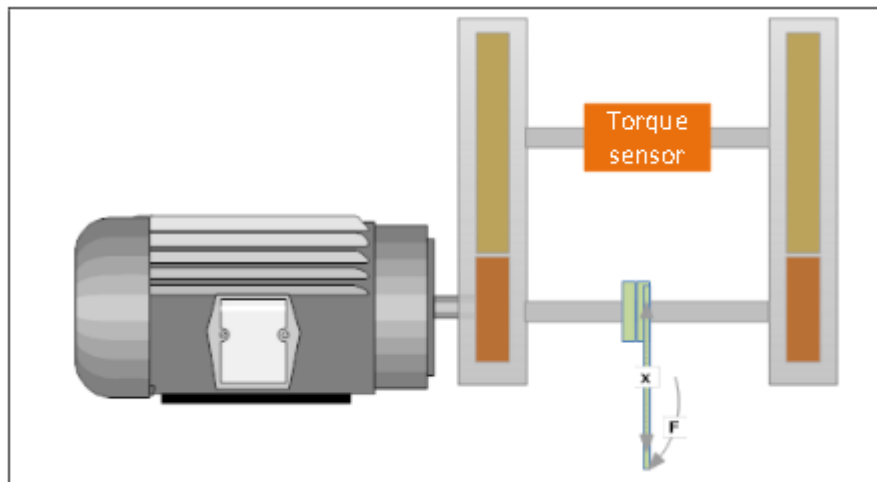

Figure 0-22: Back-to-back test bench complete gearbox

To load the transmissions a preload has to be set at 'X' and by applying a speed, different work points can be reached. The efficiency is determined by measuring the mechanical power from the motor, which is equal to the losses from the two gearboxes together. This method could work for gearboxes with parallel axes but in many cases, it is not possible to connect in - and output axes to each other. The rotation of both gearboxes is also opposite. Losses of gearboxes can be rotation dependent and gearboxes of the worm wheel type can sometimes only be run in one rotation sense. As a result, the back - to - back mechanical setup is not universally applicable.

2.9.3: Calorimetric method

This is a test method, in which the losses in a machine are deduced from the heat produced by them. With the right equipment, this would be possible to do and it can result in a very high accuracy. However, reminding that the purpose is to test at a large set of different loads and speeds, the measuring time would be very large because at every working point the whole test set up has to be thermally stabilized which would take too much time. Another way to measure the efficiency of a gearbox is to drive it with an electrical motor on one side and load the gearbox with a motor on the other side (Figure 2-22). The drive motor sets the speed, the load motor sets the torque and works as a generator.[6]

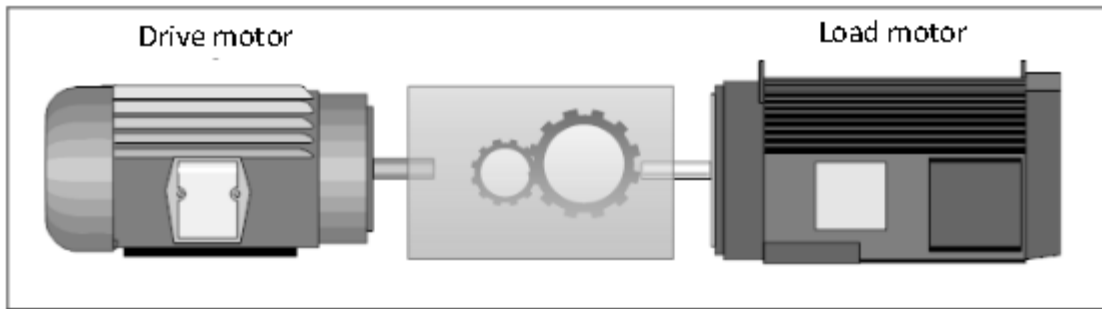

Figure 0-23: back-to-back electrical Testing

The generated energy can be used for the drive motor or can be sent back into the grid. In this case, two torque and speed measurements are necessary to determine the efficiency.

Usually a gearbox reduces the speed and enlarges the input torque. This means the load motor has to be able to deliver a large torque, which generally means a motor with higher power range. To solve this problem a second gearbox can be implemented to reduce the torque so the load and drive motor can be equally sized. This is shown in Figure 2-23. This test method is used for the test bench discussed by Defreyne [5]. This method allows a large range in types and power for gearboxes to be tested. In addition, it will be possible to measure the efficiency at different speed and load points in a flexible way. The accuracy of the efficiency determination depends on the speed and mainly on the torque measurement, so selection of these sensors will be important.

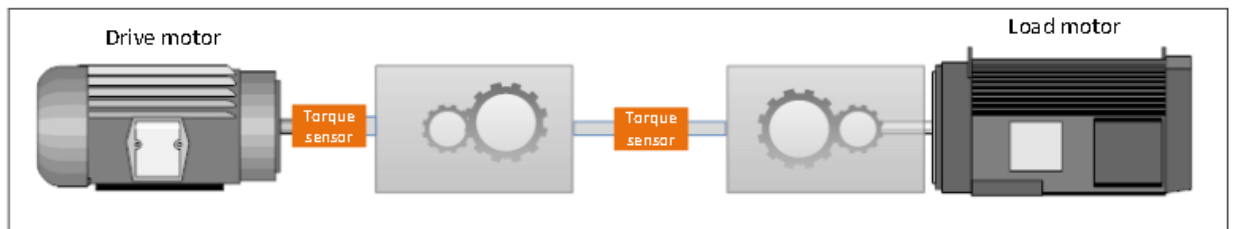

Figure 0-24: Back-to-back electrical Testing with reducer

2.9.4: Using noise emission:

To investigate noise emission from a vehicle gearbox and gear fault detection and diagnosis. **EssamAllam** used the following procedure for investigation and the schematic representation of their test rig is shown in Figure 2-24, the gearbox was running at 200RPM at 10mm for 3 hours to make the gearbox settle dynamically and it reaches a stabilized temperature of 60°C.

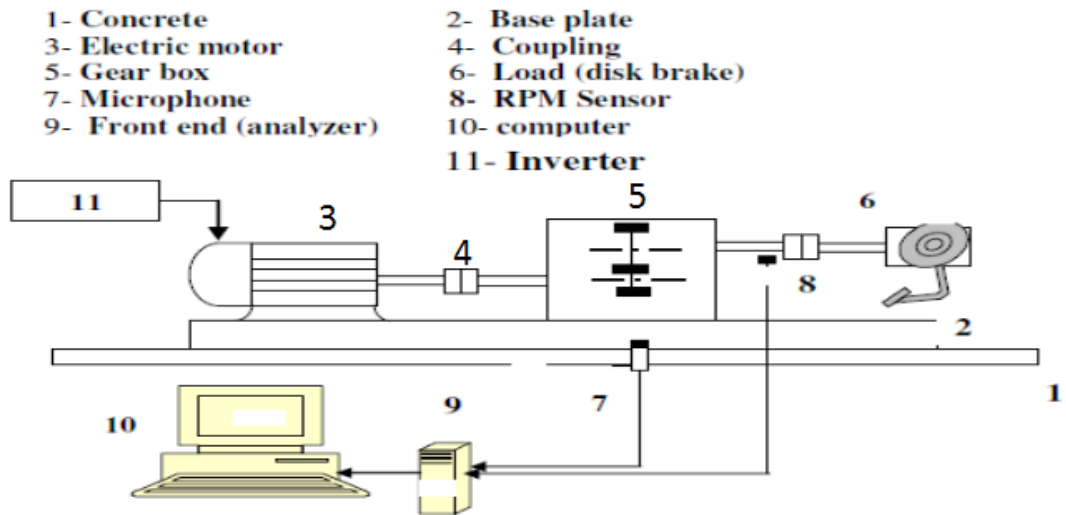

Figure 0-25: Gearbox Test Rig

Input speed of 100 to 500RPM with a torque of 2.5 to 15Nm was used as test condition. Condenser 1/2-microphone with 4189A-021 type preamplifier was placed in the center of the gearbox front casing used to measure the SPLs signals, Bruel and Kjaer (Band K) portable and multichannel PULSE type 3560-B-X05 was used to analyze the signal occurred. **C. Brecher** conducted investigation on gear noise for that acceleration sensor are mounted close to the bearings and a free- field microphone is located close to the tooth mesh. The microphone was located close to the tooth mesh and acceleration sensors are mounted near the bearing. Figure 2-25 shows the schematic representation of the test rig used for this investigation. **Åkerblom M** uses a Mechanical power-recirculation type test rig. two identical gear boxes were connected through a universal joint as shown in Figure 2-26.

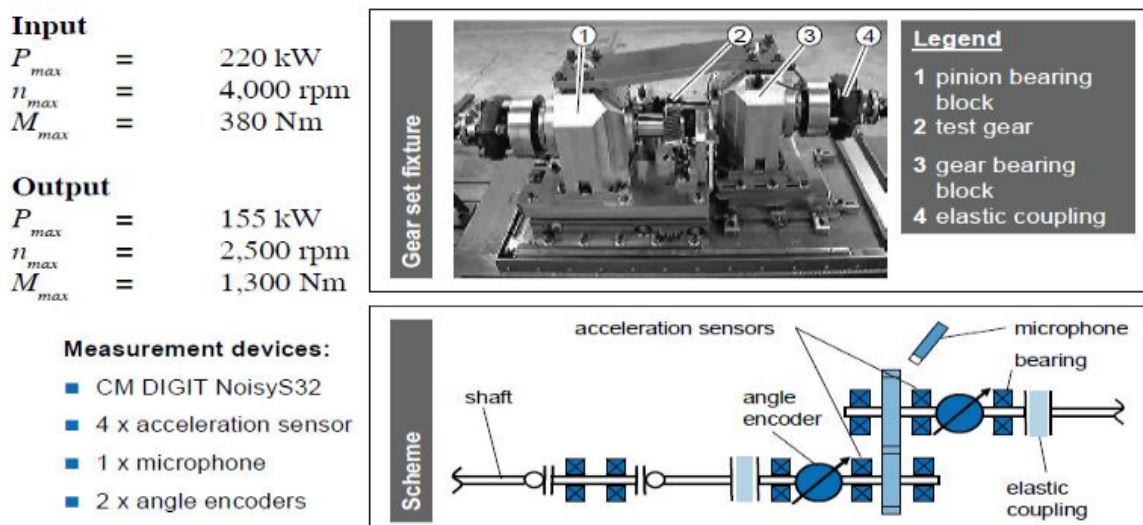

Figure 0-26: schematic representation of the gearbox test rig

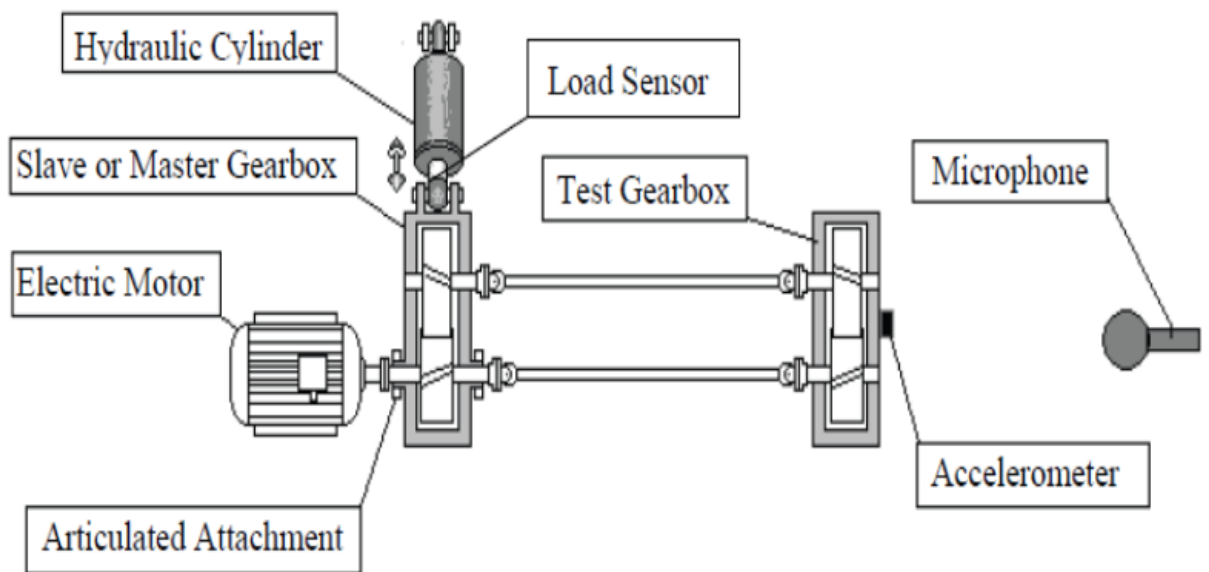
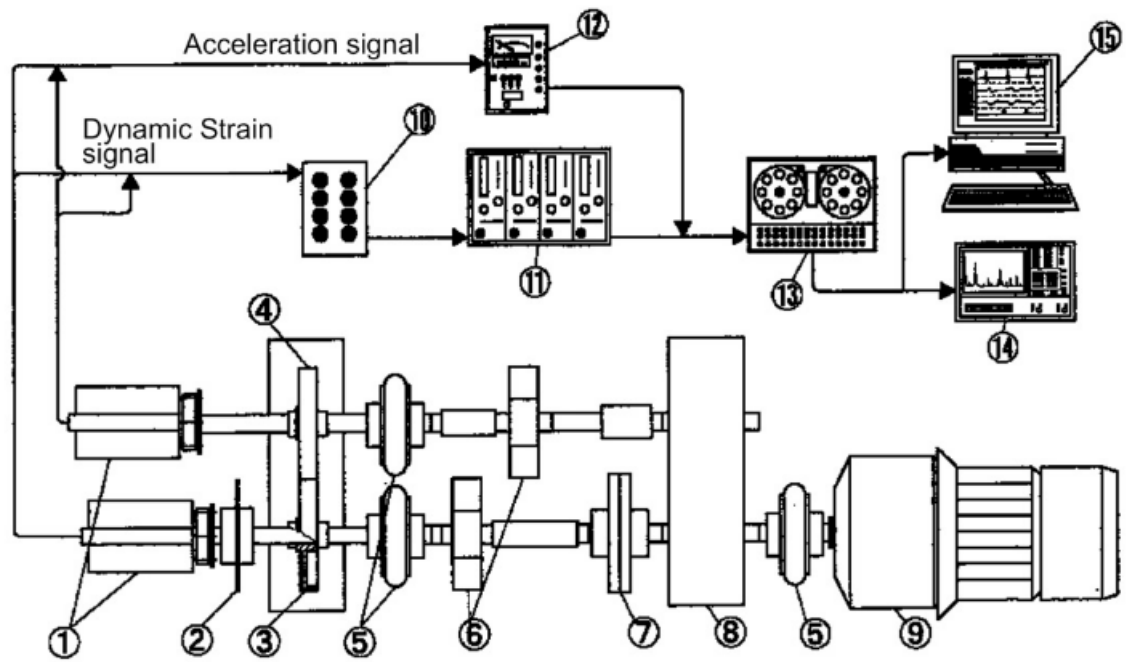

Figure 0-27: Mechanical power-recirculation type test rig

One of the gearboxes was tilted with the aid of hydraulic cylinder for applying load. Accelerometers were mounted on the gearbox for vibration measurement. Microphones were used to measure the noise. The total setup was mounted over a concrete stage. To conduct investigation on the resonance frequency behavior of spur gears **Shuting Li** used a power circulating test rig. Rubber couplings were used to avoid the effect of vibration signals from motor and shaft. Construction of this test rig is shown in Figure 2-27.



- (1)Slip ring (2)Gear for speed test (3)Test gear (Thin-walled gear) (4)Solid gear
 (5)Rubber coupling (6)Bearing support (7)Torque-loading coupling (8)Power circulating gear box
 (9)Speed-variable motor (10)Bridge box (11)Dynamic strain amplifier (12)Acceleration amplifier
 (13)Data recorder (14)FFT analyzer (15)Personal computer

Figure 0-28: power circulating gearbox test rig

Chapter 3

Methodology

3.1: Introduction:

This chapter illustrates the design calculations and work procedures that has been used to build the model device and the experimental work that has been executed to obtain the results, which will be presented in the next chapter.

3.2: The gearbox design concepts:

The gearbox designed to ensure:

- (a) Variation of traction power of the tracks and speed of the vehicle movement within wider limits than it is possible by changing speed.
- (b) Reverse movement of the vehicle.
- (c) Idling for engine when starting it and at halt.

The gearbox is of step type with constant meshing of gears. It provides for five forward speeds and one reverse speed. Changing of the gearbox ratios (gear shifting) providing a possibility for variation of traction power of the tracks and the running speed of the vehicle within wide limits, ensures driving on different grounds and overcoming the vehicle inertia when placing the tank in motion and during speeding up.

Gear shifting is accomplished by moving the slide-toothed sleeves. To facilitate engagement of gears, the gearbox is provided with synchronizers.

The gearbox is installed in the vehicle's rear on two rears and one front bracket. The rear brackets are bolted to the pads welded to the vehicle's bottom [7].

3.3: Gear ratios and speed calculations:

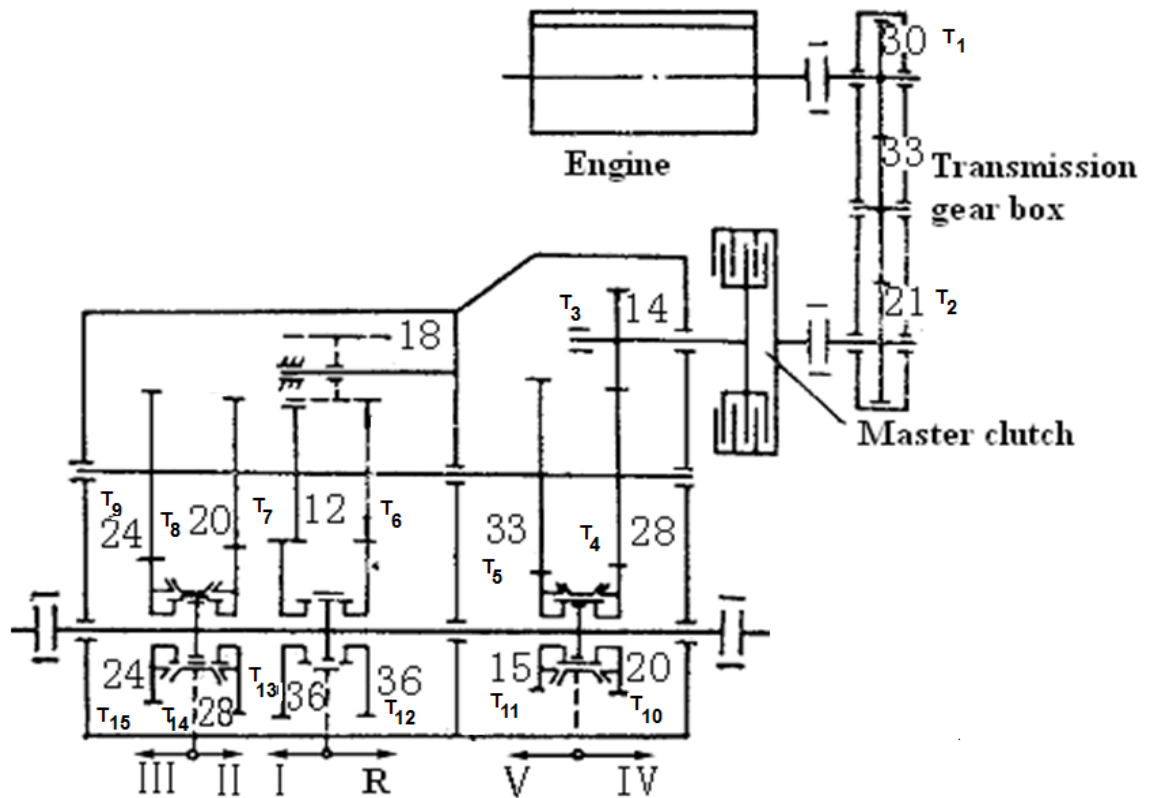

Figure 3-1: Schematic diagram for the heavy vehicle gearbox

3.3.1: Speed Ratios

From Figure 3-1 above, we can find that:

The speed ratio varies from gear to other and it is calculated for the different speeds of the gearbox as follows:

1. The 1st speed: $R_1 = \frac{T_1}{T_2} \times \frac{T_4}{T_3} \times \frac{T_{13}}{T_7} = \frac{21}{30} \times \frac{28}{14} \times \frac{36}{12} = 4.2$
2. The 2nd speed: $R_2 = \frac{T_1}{T_2} \times \frac{T_4}{T_3} \times \frac{T_{14}}{T_8} = \frac{21}{30} \times \frac{28}{14} \times \frac{28}{20} = 1.96$
3. The 3rd speed: $R_3 = \frac{T_1}{T_2} \times \frac{T_4}{T_3} \times \frac{T_{15}}{T_9} = \frac{21}{30} \times \frac{28}{14} \times \frac{24}{24} = 1.4$
4. The 4th speed: $R_4 = \frac{T_1}{T_2} \times \frac{T_4}{T_3} \times \frac{T_{10}}{T_4} = \frac{21}{30} \times \frac{28}{14} \times \frac{20}{28} = 0.71$
5. The 5th speed: $R_5 = \frac{T_1}{T_2} \times \frac{T_4}{T_3} \times \frac{T_{11}}{T_5} = \frac{21}{30} \times \frac{28}{14} \times \frac{15}{33} = 0.45$

$$6. \text{ Thereversespeed: } R_R = \frac{T_1}{T_2} \times \frac{T_4}{T_3} \times \frac{T_{12}}{T_6} = \frac{21}{30} \times \frac{28}{14} \times \frac{36}{12} = 4.2$$

3.3.2: The rotation speed

The calculation of rotation speed of different components is as follows:

1. *The rotating speed of the driving electrical motor:*

$$N_1 = 500 \text{ r.p.m}$$

$$\frac{N_1}{N_2} = \frac{T_2}{T_1}$$

2. *The rotating speed of the main shaft of the gearbox (N2):*

$$N_2 = \frac{T_1}{T_2} \times N_1 = \frac{30}{21} \times 500 \cong 700 \text{ r.p.m.}$$

3. *The rotating speed of the medium shaft of the gearbox :*

$$N_3 = \frac{T_3}{T_4} \times N_2 = \frac{14}{28} \times 700 = 350 \text{ r.p.m}$$

4. *The output rotating speed using the 1st speed gear :*

$$N_I = \frac{T_7}{T_{13}} \times N_3 = \frac{12}{36} \times 350 = 117 \text{ r.p.m.}$$

5. *The output rotating speed using the 2nd speed gear:*

$$N_{II} = \frac{T_8}{T_4} \times N_3 = \frac{20}{28} \times 350 = 250 \text{ r.p.m}$$

6. *The output rotating speed using the 3rd speed gear:*

$$N_{III} = \frac{T_9}{T_{15}} \times N_3 = \frac{24}{24} \times 350 = 350 \text{ r.p.m}$$

7. *The output rotating speed using the 4th speed gear:*

$$N_{IV} = \frac{T_4}{T_{10}} \times N_3 = \frac{28}{20} \times 350 = 490 \text{ r.p.m.}$$

8. *The output rotating speed using the 5th speed gear:*

$$N_V = \frac{T_5}{T_{11}} \times N_3 = \frac{33}{15} \times 350 = 770 \text{ r.p.m}$$

Figures 3-2 to 3-5 show examples for the speeds of the gearbox.

9. *The output rotating speed using the reverse speed gear:*

$$N_R = \frac{T_3}{T_4} \times N_2 = \frac{12}{36} \times 700 = 117 \text{ r.p.m.}$$

Figure 3-6

Neutral

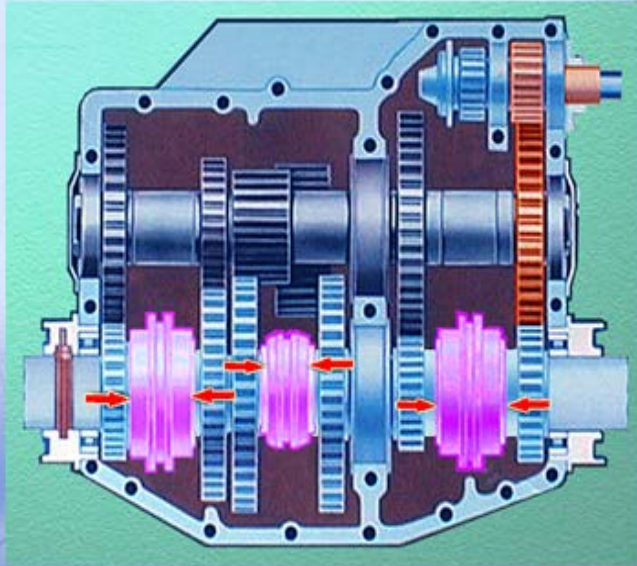

Figure 3-2: the Neutral Position

Forward speeds - 1st speed

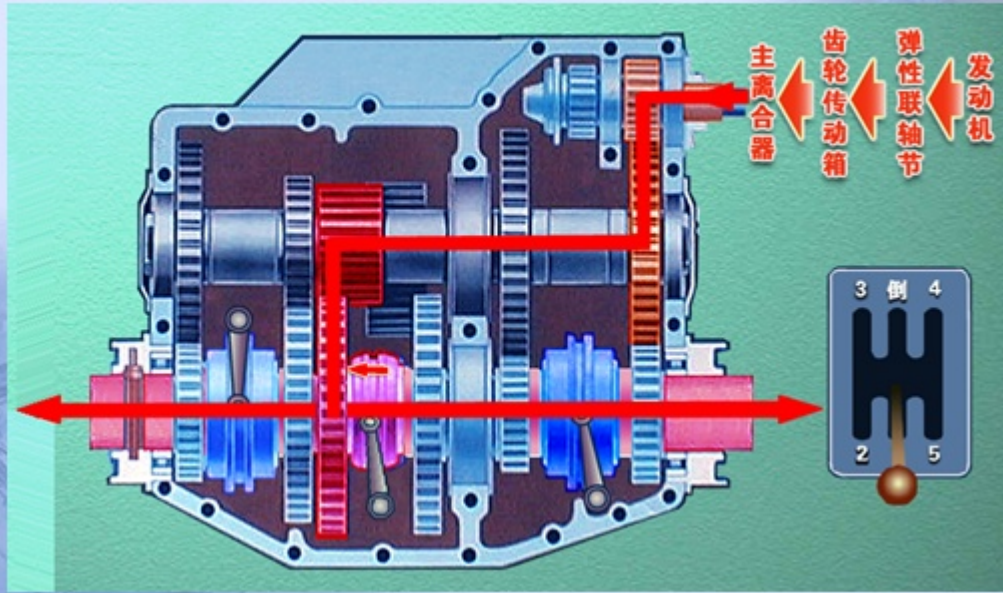

Figure 3-3: The Gearbox 1st speed

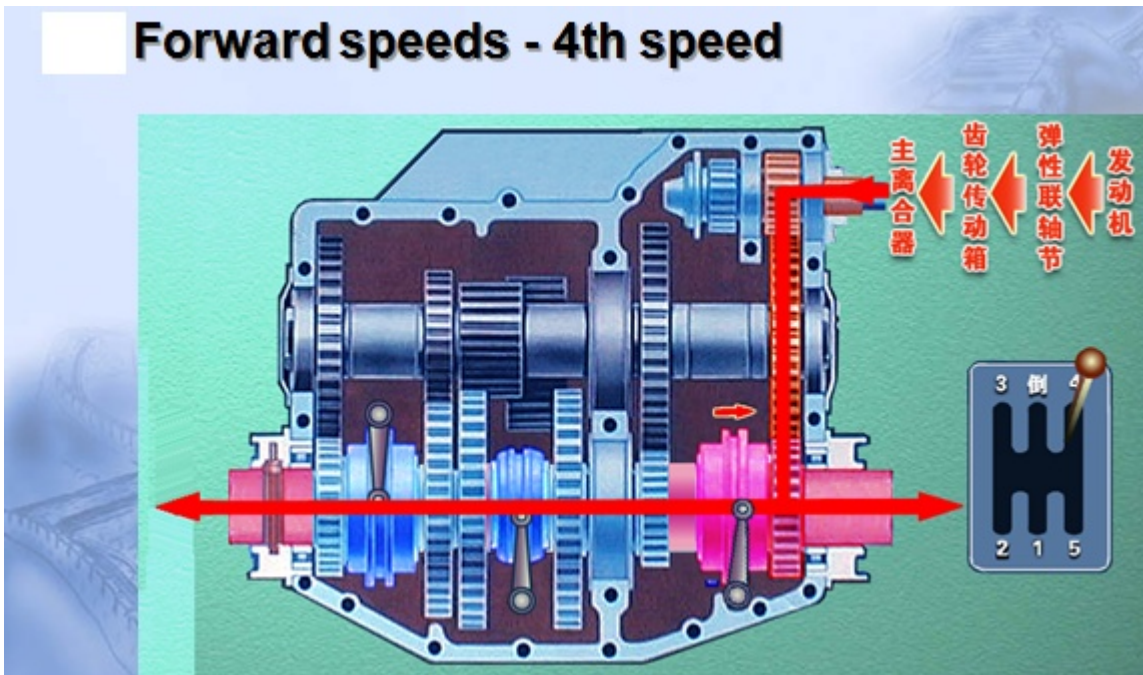

Figure 3-4: The Gearbox 4th speed

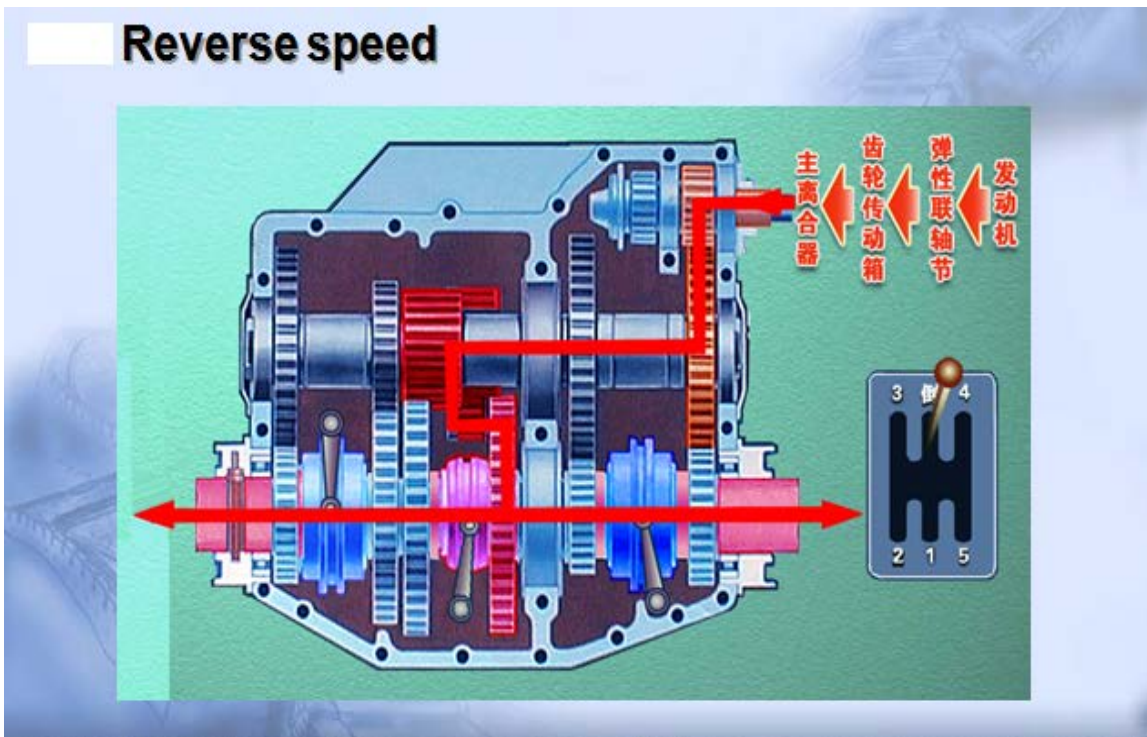

Figure 3-5: The Gearbox Reverse speed

3.4: The test rig Design Steps:

Designing steps include calculating the following:

- The moment of inertia for the speed changing gearbox (I_g).
- The torque of the speed changing gearbox (T_g).
- The power needed for the speed changing gearbox (P_g).
- The power of the electrical motor (P_m).
- The diameter of the connecting shaft (d).
- Selecting the size of the small pulley & type of the belt.

3.4.1: The moment of inertia of the gearbox.

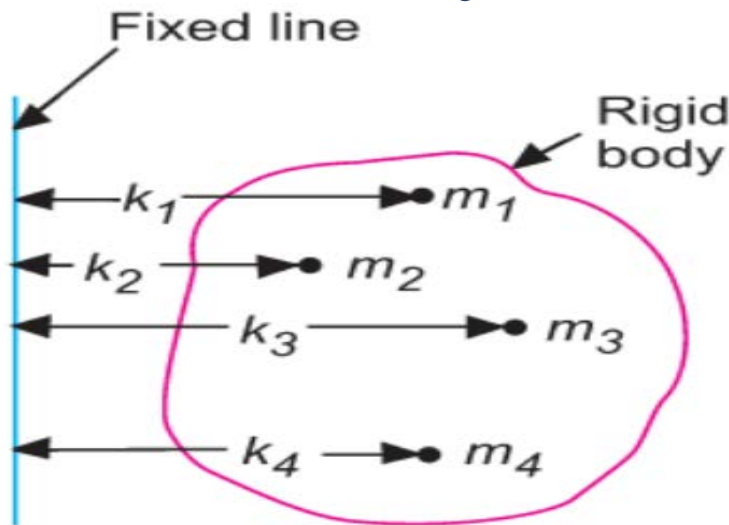

Figure 3-6: The moment of Inertia

$$I = m_1 k_1^2 + m_2 k_2^2 + m_3 k_3^2 + m_4 k_4^2 + \dots$$

The total mass of body is assumed to concentrate at one point (the center of mass or center of gravity), at a distance k from the given axis, such that $mk^2 = m_1(k_1)^2 + m_2(k_2)^2 + m_3(k_3)^2 + m_4(k_4)^2 + \dots$

Then $I = mk^2$

The distance (k) is called the radius of gyration. It is defined as the distance, from a given reference, where the whole mass of body is assumed to be concentrated to give the same value of (I).

The unit of mass moment of inertia in S.I. units is kg.m^2 .

If the moment of inertia of a body about an axis through its center of gravity is known, then the moment of inertia about any other parallel axis may be obtained by using a parallel axis theorem (khurmi).

I.e. moment of inertia about a parallel axis, $I_p = I_G + m \times h^2$

Where:

I_G = Moment of inertia of a body about an axis through its center of gravity

h = Distance between two parallel axes [1]

The above formula it is used to calculate the moment of inertia.

To calculate the moment of inertia for the speed changing gearbox (I_g) in this research Solid Work program is used (Figure 3-7).

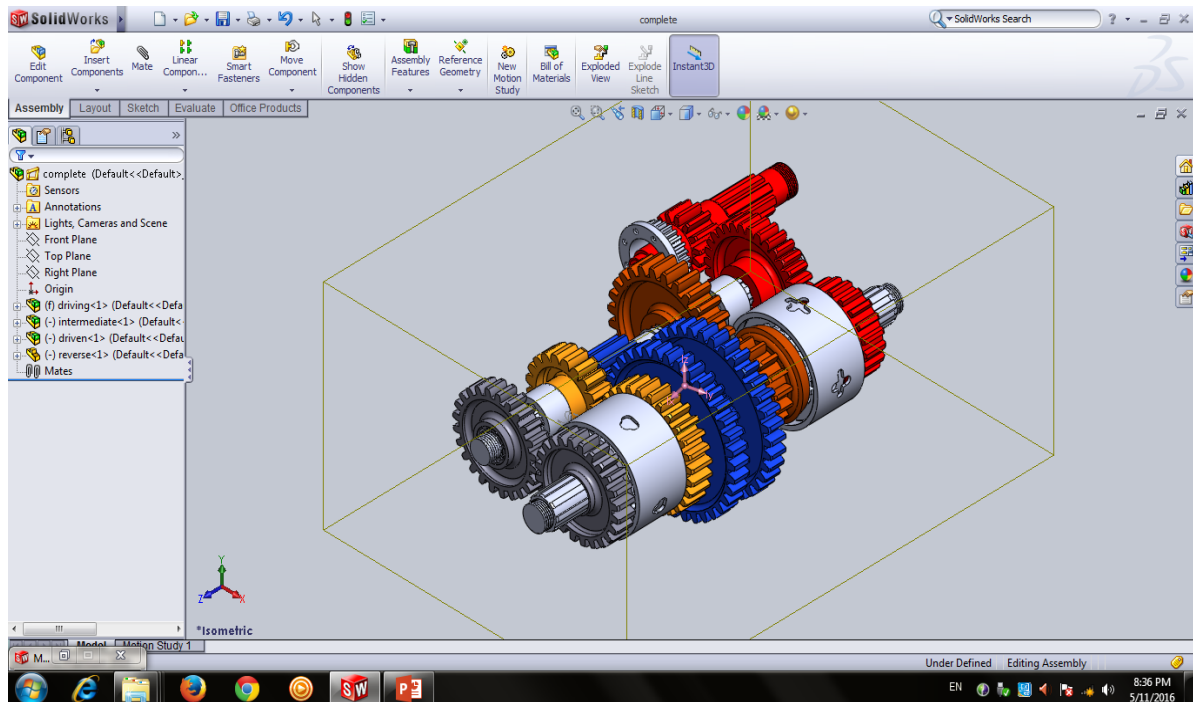

Figure 3-7: CAD Drawing for the vehicle gearbox

After finishing, the CAD Drafting Solid Work will calculate the Mass Properties for the gearbox including the moment of Inertia (Figure 3-8).

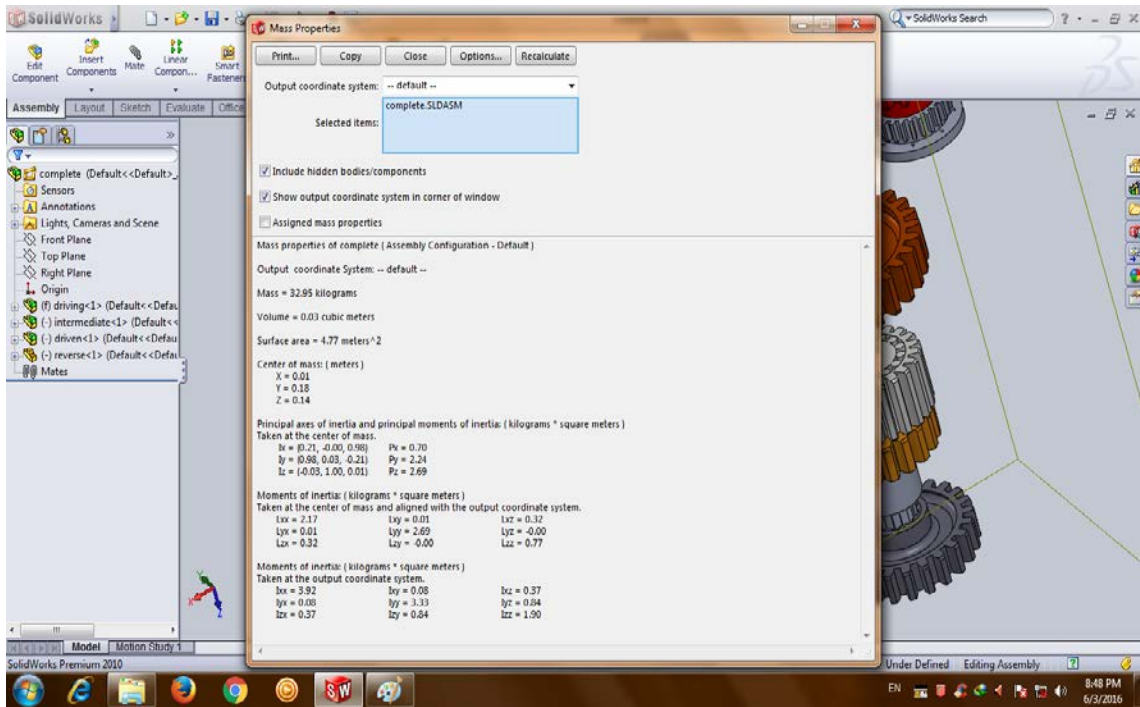

Figure 3-8: Solid Work mass Properties

From the program after modeling the gearbox $I_g = 0.77\text{kg.m}$

3.4.2: The torque of the speed changing gearbox (T_g).

$$T_g = I_g \times \alpha$$

Where:

T_g : The torque of the speed-changing gearbox

I_g : The moment of inertia for the speed-changing gearbox

α : the accelerate angular

$$\omega = \omega_0 + \alpha t$$

where:

ω_0 : Initial angular velocity in of the main shaft of the gearbox in rad/s.

ω : Final angular velocity of the main shaft of the gearbox in rad/s.

The input speed to the gearbox is:

$$\therefore N = 500 \times \frac{30}{21} = 700\text{rpm}$$

Where:

N: The rotating speed of the main shaft of the gearbox.

Assume $t = 0.5$ second & $\omega_0 = 0$

$$\omega = \frac{2\pi N}{60} = \frac{2\pi \times 700}{60} = 73.30\text{rad/s}$$

$$\alpha = \frac{\omega}{t} = \frac{73.30}{0.5} = 146.6\text{rad/s}^2$$

$$\therefore T_g = 0.77 \times 146.6 = 112.88 \text{ N.m}$$

3.3.3 The power needed for the speed-changing gearbox

$$P_g = T_g \times \omega = 112.88 \times 73.3 = 8274.25 \text{ w} = 8.3 \text{ kw}$$

Where:

P_g : Power needed for the speed-changing gearbox = 8.3kw = 12hp

3.4.3: The power of the electrical motor (P_m)

Assuming the loses power from motor to the pulley and transmission gear is 0.8&0.85

Then the total efficiency $\eta = 0.8 \times 0.85 = 0.68$

$$\therefore P_m = \frac{P_g}{\eta} = \frac{8.3}{0.68} = 12 \text{ kw} = 16 \text{ hp}$$

3.4.4: Connecting shaft Diameter (D)

Figure 3-9 bellow explains the Forces acting on the connecting shaft

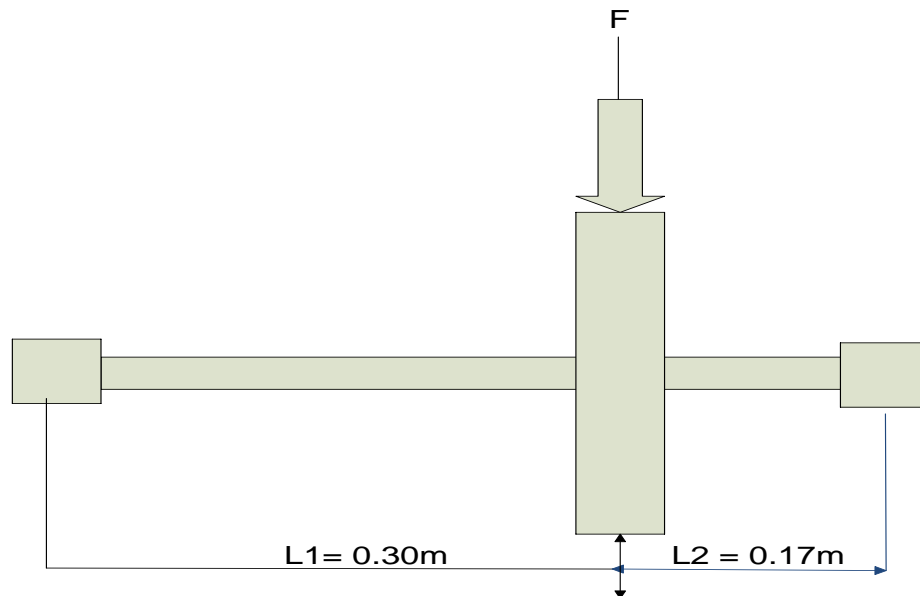

Figure 3-9: loads on the shaft

$$D = \left[\frac{32 \times F.S}{\pi \times S_y} [M^2 + T_s^2]^{1/2} \right]^{1/3}$$

Where:

F.S: The factor of safety.

S_y : The yield stress of the shaft.

M : The bending moment of the shaft.

T_s : The torque of shaft.

$$T_s = \frac{P_m}{\omega} = \frac{12 \times 10^3}{2 \times \pi \times 500} = 229.18 \text{ N.m}$$

$$F = \frac{T_s}{R}$$

Where:

F: force applied on the shaft.

R: the radius of the big pulley.

From Table 3-1 the small pulley diameter is 4.2in according to the power of the electrical motor.

The ratio of speed between the motor and the pulley = $\frac{1400}{500} = 2.8 : 1$

The radius of the big pulley = $2.8 \times 4.2 = 11.76 \text{ in} = 30 \text{ cm} = 0.30 \text{ m}$.

$$\therefore F = \frac{229.18}{0.30} = 764 \text{ N}$$

$$M = \frac{L_1 \times L_2 \times F}{L} = \frac{0.30 \times 0.17 \times 764}{0.47} = 82.9 \text{ N.m}$$

Assuming the factor of safety F.S = 1.25

And $S_y = 240 \text{ MPa}$

$$D = \left[\frac{32 \times 1.25}{\pi \times 240 \times 10^6} [82.9^2 + 229.18^2]^{1/2} \right]^{1/3} = 0.0235 \text{ m} = 23.5 \text{ mm}$$

Take the diameter = 25mm

3.4.5: Selecting the size and type of the belt.

$$L_p = 2C + \frac{\pi(D + d)}{2} + \frac{(D - d)^2}{4C}$$

Where:

L_p : The pitch length.

C: The center-to-center distance.

D: pitch diameter of the large pulley. = 11.76 inch

d: pitch diameter of the small sheave. = 4.2 inch

From (Appendix 1):

The C = 42inch (should not be greater than 3 times the sum of the sheave diameter).[1]

$$L_p = 2 \times 42 + \frac{\pi(11.76 + 4.2)}{2} + \frac{(11.76 - 4.2)^2}{4 \times 42}$$

$$= 84 + 25.07 + 0.68 = 109.75 \text{ in.}$$

$$H_a = K_1 K_2 H_{\text{tab}}$$

Where:

H_{tab} : The tabulated power value (Table 3-1).

H_a : Allowable power, per belt.

K_1 : Angle-of-wrap correction factor (Appendix 1).

K_2 : Belt length correction factor (Appendix 1).

From the tables mentioned above:

$$K_1 = 0.99$$

$$K_2 = 1.05$$

$$H_{\text{tab}} = 1.325$$

$$\therefore H_a = 0.99 \times 1.05 \times 1.325 = 1.377$$

$$N_b \geq \frac{H_d}{H_a} N_b = 1, 2, 3, \dots$$

$$H_d = H_{\text{nom}} K_s n_d$$

Where:

N_b : The number of the belt.

H_{nom} : The nominal power. = 12hp

K_s : The service factor given in (Appendix 1). = 1.5

n_d : The design factor. = 0.20

$$\therefore H_d = 12 \times 1.5 \times 0.20 = 3.6\text{hp}$$

$$\therefore N_b = \frac{3.6}{1.377} = 2.614 \cong 3\text{belts}$$

Table 3-1: Horsepower Ratings of Standard V- Belt

Belt Section	Sheave Pitch Diameter, in	Belt Speed, ft/ min				
		1000	2000	3000	4000	5000
A	2.6	0.47	0.62	0.53	0.15	
	3.0	0.66	1.01	1.12	0.93	0.38
	3.4	0.81	1.31	1.57	1.53	1.12
	3.8	0.93	1.55	1.92	2.00	1.71
	4.2	1.03	1.74	2.20	2.38	2.19
	4.6	1.11	1.89	2.44	2.69	2.58
	5.0 and up	1.17	2.03	2.64	2.96	2.89
B	4.2	1.07	1.58	1.68	1.26	0.22
	4.6	1.27	1.99	2.29	2.08	1.24
	5.0	1.44	2.33	2.80	2.76	2.10
	5.4	1.59	2.62	3.24	3.34	2.82
	5.8	1.72	2.87	3.61	3.85	3.45
	6.2	1.82	3.09	3.94	4.28	4.00
	6.6	1.92	3.29	4.23	4.67	4.48
7.0 and up	2.01	3.46	4.49	5.01	4.90	
C	6.0	1.84	2.66	2.72	1.87	
	7.0	2.48	3.94	4.64	4.44	3.12
	8.0	2.96	4.90	6.09	6.36	5.52
	9.0	3.34	5.65	7.21	7.86	7.39
	10.0	3.64	6.25	8.11	9.06	8.89
	11.0	3.88	6.74	8.84	10.0	10.1
	12.0 and up	4.09	7.15	9.46	10.9	11.1

3.5: The Final Test Rig

The final test rig was manufactured according to block diagram for components (Figure 3-11).

This device is composed of the following:

- a) Base frame for holding the different parts.
- b) Tested gearbox.
- c) Intermediate gearbox.
- d) Electrical motor.
- e) Connecting shaft, pulley, & belt.
- f) Gear changing mechanism.

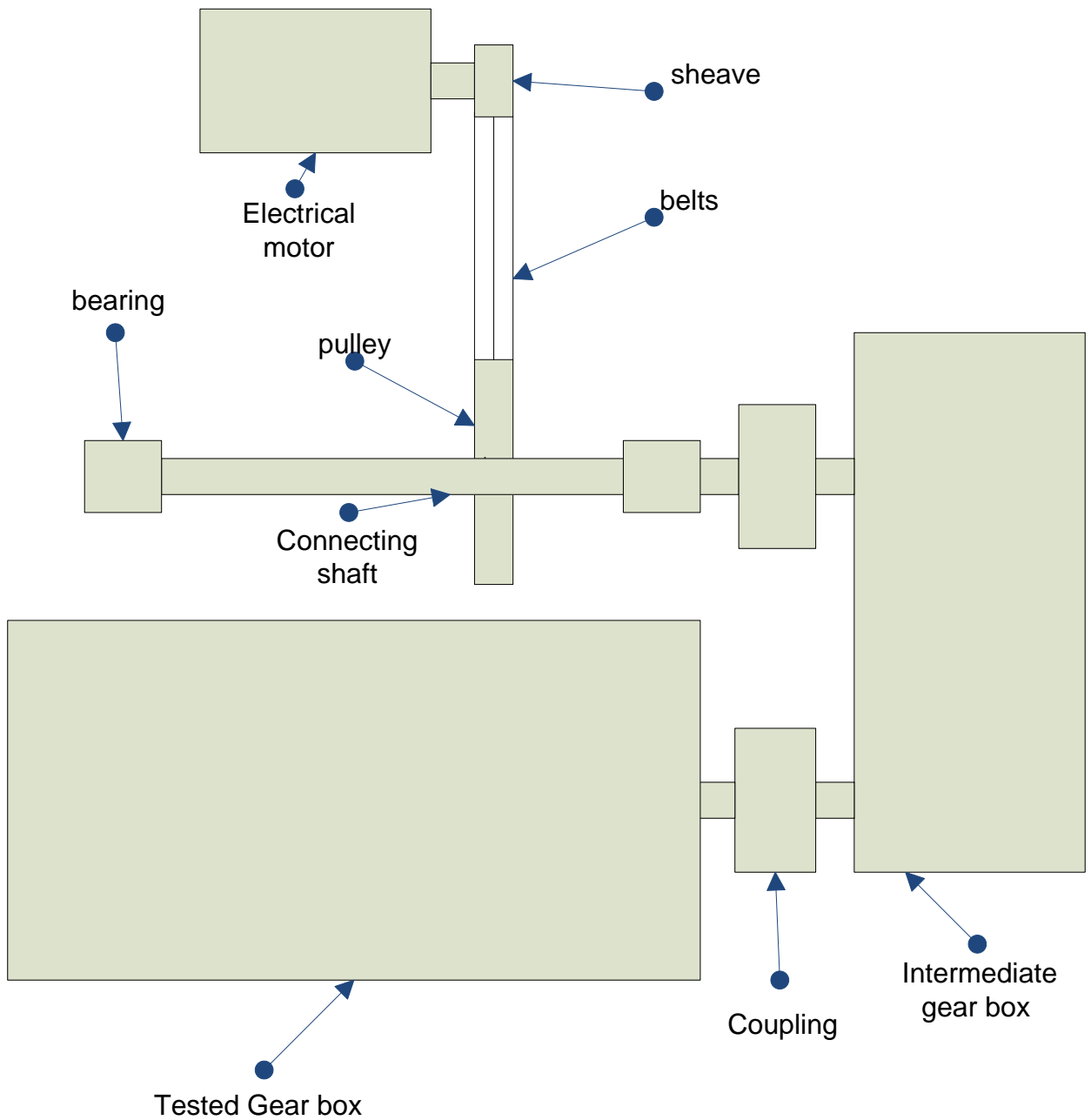

Figure 3-10: Block Diagram of the Final Test rig

The testing rig for gearbox of the heavy vehicle (Figure 3-11) is designed and used to inspect the output revolution speed for different gears

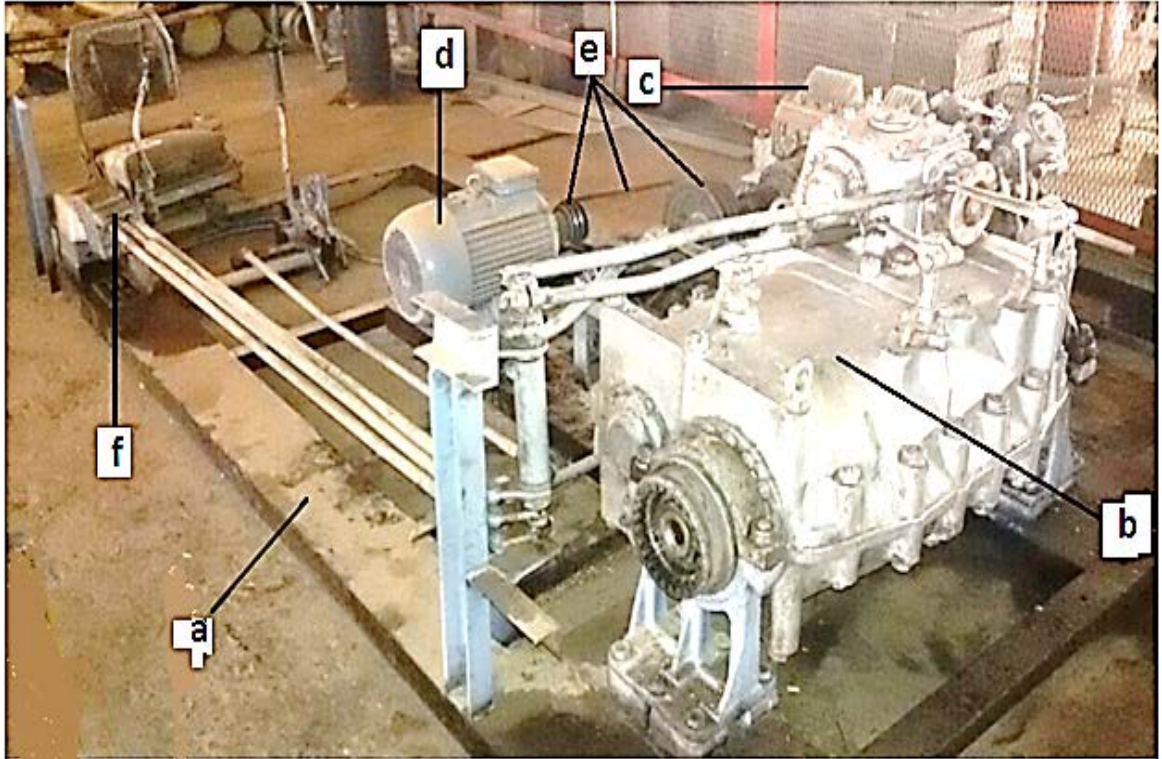

Figure 3-11: heavy vehicles gearbox testing rig

Chapter 4 Results

4.1: Measured speeds:

After the designed and implementation of the gearbox testing device; a gearbox was tested by it and the different revolution speed was measured by a digital tachometer testing device (Figure 4-1).



Figure 4-1: Digital Tachometer

Readings were as follow (Table 4-1).

From this table it is shown that the gearbox testing rig properly working and it will ready to detect gearbox failure, damage and other manufacturing errors.

Gear No	Measured speed(rpm)
I	358
II	516
III	818
IV	1043
V	1400
R	358

Table 4-1: measured speed

4.2: Calculated Speeds:

The measured speed is then compared with the calculated speed and the result was presented in Table 4-2.

When comparing the measured speed with the calculated speed it is appear that there is difference between the calculated and measured speed, and that is because the calculated speed is based on an input motor speed of 1400 rpm while the motor used in the test rig is of a speed of 2400 rpm.

Gear No	Measured speed(rpm)	Calculated speed(rpm)
I	358	117
II	516	250
III	818	350
IV	1043	490
V	1400	770
R	358	117

Table 4-2: Calculated and Measured Speeds

Chapter 5 Conclusion and recommendation

5.1: Conclusion:

The purpose of this thesis was to check and inspection the gearbox before and after maintenance by using the gearbox test rig to make the testing of gearboxes easier after maintenance outside the vehicle. In addition, testing and monitoring the different speeds and measuring it easy.

The testing rig does not include build in speed measuring sensor so portable laser speed measuring device was used.

There is difference between calculated output speeds and the actual measured output speeds; due to the difference between the electrical motor speeds actually used and the motor used in calculation.

5.2: Recommendations:

To improve the test rig number of sensors should be added to measure the speed, noise, heat,& vibration.

For testing the load applied, a break torque device can be added. The gearbox test rig can be upgraded and improving to test different kind gearboxes by adding more adjustable parts to the device.

This field needs more research & a number of thesis can be done.

References

1. Khurmi, R. S. and Gupta, J. K. Theory of Machines. s.l. : S. Chand & Company Ltd., 2006. ISBN 81-219-2524-X.
2. Bulacio, Horacio. Power Conversion Validation and Reliability. s.l. : Vestas Wind Systems A/S, 2014.
3. ROSTAMI, Ali, et al. GEARBOX FAULT DETECTION USING VIBRATION SIGNALS BASED ON THE METHOD OF HILBERT. 2014. pp. 675-689.
4. Bohnstedt, H. J. Fruherkennug von Wellenrissen bei Turbosatzendurch Überwachung der Schwingungen. s.l. : Allianz Berichte, 2003.
5. Defreyne, P, et al. An energy efficiency measurement test bench for gearboxes. 2013.
6. Del valle, Prakash Carlos. Thermal modelling of an FZG Test gearbox: Master of Science Thesis. 2014.
7. NORINCO. Operational Manual for T-85. feuchin, china : NORINCO, 2003.
8. Childs, peter R. N. mechanical design. University of Sussex, UK : Arnold, 2004. ISBN 0 7506 5771 5.
9. rickson, Alan Hend. MECHANICAL DESIGN for the stage. USA : Services Manager: George Morrison, 2008. ISBN: 978-0-240-80631-0.
10. Harold A. Rothbart, Thomas H. Brown, Jr. MECHANICAL DESIGN HANDBOOK. USA : McGraw-Hill Companies, , 2006. 9-78-007148735-1.