

1.1 General View

Sleep Apnea is an illness described as a temporary breathing stop or a type of discontinued breathing during sleep. There is about 1 of each 5 adults who has sleep apnea issue, but about 80% of them don't realize that they have it so they keep it without any diagnosis or further treatment. Sleep apnea is often accompanied with snoring . Sleep apnea is a common medical disorder that occurs when breathing is disrupted during sleep . Sleep is a topic near and dear to everyone's heart. It is both essential and wonderful; however, optimal, restful sleep requires rotation through all stages with minimal interruptions. The effects of poor sleep can be a burden on not only a person's psyche and mental well-being with symptoms ranging from forgetfulness to depression, but may also cause physical manifestations such as weight gain, skin aging, and increasing a person's risk for overall mortality. As our understanding of sleep increases, it becomes equally important to develop methods of testing for poor sleep quality with increasing efficiency ,reliability and access.

1.2 Problem Statement

Sleep Apnea Detection device is costly ,and have Very complicated electronic circuit.

1.3 Objective

General objective

The general objective is to Design and implementation of obstructive sleep apnea detection.

1.4 Research Methodology

Our circuit consist of two sensors(flow and pulse oximeter sensor) ,also we have power supply that operate the elements of the circuit ,micro

controller which control the operations ,finally LCD ,buzzer and leds act as outputs.

1.5 Thesis layout

This research consist of six chapters ,along with appendixes :-

Chapter one is an introduction, previous studies are given in chapter two, chapter three represent theoretical background ,the proposed design and is represented in chapter four, chapter five contain results, finally chapter six consist of conclusion and recommendations.

To understand how detect obstructive sleep apnea .The past studies have considered. That is to start where the other stopped, try to solve problems and understanding the difficult of such project and what would it add to the scientific community.

Yashar Maali and Adel Al-Jumaily at 2012 proposed a genetic fuzzy approach for detecting Apnea/Hypopnea events by using Air flow, thoracic and abdominal respiratory movement signals and Oxygen desaturation as the inputs. Results show efficiently of this approach. This paper presents using of fuzzy inference system, but fuzzy rules are generated by genetic algorithms. Using this approach helps to reach a better accuracy and save time that required establishing the fuzzy rules by interview the specialist, especially when they have different opinions about a same case. The rest of this paper is organized as, pre-processing phase and signal analysis and quantification in section 2, basic of proposed fuzzy inference and genetic algorithm reviewed in section 3 and finally, results and conclusion are presented in section 4 and 5 respectively.[1]

Piotr Przystup, Adam Bujnowski, Jacek Rumiński, and Jerzy Wtorek at 2014 developed device allows all-night recordings of the following biosignals: three channels ECG, thoracic impedance (respiration), snoring sounds and larynx vibrations. Additional information, like patients body position changes and electrodes attachment quality are estimated as well. The reproducible and high quality signals are obtained using the developed and unobtrusive device.The main goal of this paper is to present the results of the research on a new device development allowing simultaneous measurement of appropriate signals for analysis of sleep disorders using a limited set of connections attached to the diagnosed person. [2]

Cafer Avci, Gökhan Bilgin at 2013 presented an efficient and easy implemented method for detecting minute based analysis of sleep apnea. The nasal, chest and abdominal based respiratory signals extracted from polysomnography recordings are obtained from PhysioNet apnea-ECG database. Wavelet transforms are applied on the 1-minute and 3-minute length recordings. According to the preliminary tests, the variances of 10th and 11th detail components can be used as discriminative features for apneas. The features obtained from total 8 recordings are used for training and testing of an adaptive neuro fuzzy inference system (ANFIS). Training and testing process have been repeated by using the randomly obtained five different sequences of whole data for generalization of the ANFIS. According to results, ANFIS based classification has sufficient accuracy for apnea detection considering of each type of respiratory. However, the best result is obtained by analyzing the 3-minute length nasal based respiratory signal. In this study, classification accuracies have been obtained greater than 95.2% for each of the five sequences of entire data.[3]

Agnel John K.J, Pamela .D at 2015 introduced a mathematical representation of respiratory pattern in frequency domain. apnea).Microcontroller based sleep apnea monitor consists of a piezoelectric sensor attached to rib cage of patient. The amplified signal obtained from the patient is applied to the microcontroller. The method mentioned in the paper is based on extraction of four enhanced main energy features of respiratory signal from 30 second respiratory data through auto regressive modeling and other techniques. The four features extracted are Signal power, Respiration frequency, Dominant frequency in power spectrum, Maximum power in spectrum . These features are

compared with their threshold values and introduced to a series of condition for each epoch.[4]

Majdi Bsoul and Lakshman Tamil at 2011 developed a low-cost, real-time sleep apnea monitoring system “Apnea MedAssist” for recognizing obstructive sleep apnea episodes with a high degree of accuracy for both home and clinical care applications. The fully automated system uses patient’s single channel nocturnal ECG to extract feature sets, and uses the support vector classifier (SVC) to detect apnea episodes. “Apnea MedAssist” is implemented on Android operating system (OS) based smartphones, uses either the general adult subject-independent SVCmodel or subject-dependent SVCmodel, and achieves a classification F-measure of 90% and a sensitivity of 96% for the subject-independent SVC. The real-time capability comes from the use of 1-min segments of ECG epochs for feature extraction and classification. The reduced complexity of “Apnea MedAssist” comes from efficient optimization of the ECG processing, and use of techniques to reduce SVC model complexity by reducing the dimension of feature set from ECG and ECG-derived respiration signals and by reducing the number of support vectors.[5]

3-1 The Anatomy of the respiratory system

Basic functions of the respiratory system is gas exchange and supply oxygen to aerobic tissues in the body and remove carbon dioxide as a waste product.

Pulmonary ventilation

The physics of getting air in-to and out-of the lungs (ventilation)

External respiration

gas exchange between the lungs and blood (oxygen loading and CO₂ unloading) transport of respiratory gases and movement of blood (thus gases) from the lungs to the cell and tissues.

Internal respiration

Gas exchange between the capillaries and the tissues (oxygen unloading and CO₂ loading).

3-1-1 Functional anatomy of the respiratory system (conducting zone)

Nose

Airways, moistens and warms air, filters inspired air, resonating chamber for speech, and olfaction.

Paranasal sinuse

frontal, sphenoid, ethmoid and maxillary bone. warm and moisten air
Pharynx, and connects the nasal cavity and mouth to the larynx and esophagus. [6]

Laryngo pharynx

common passage way for food and air Larynx, and voice box.

The Trachea

Windpipe, larynx at division forming two primary bronchi at Midthorax, and mucosa pseudostratified.

epithelium (goblet cells)

sub mucosa –connective tissue, Sero mucous glands –mucous , and adventitia –CT hyaline cartilage.

Bronchi

Bronchial tree left and right primary bronchi formed by divisions of the trachea. secondary bronchi (lobar) inside the lungs, 3 on the right. And 2 on the left. tertiary bronchi (segmental). fourth-order. fifth-order 23 orders of branching air ways. bronchioles (under 1 mm in diameter).

Bronchioles

bronchioles (under 1 mm in diameter),and terminal bronchioles (less than 0.5 mm).

Cartilage

Rings, irregular plates, no cartilage in bronchioles, and replaced by elastic fibers.

Epithelium

Pseudo stratified (ciliated), columnar (ciliated), and cuboidal in terminal bronchioles (no cilia).

Smooth Muscle

Increase as tube get smaller.[7]

3-1-2 Respiratory Zone

Respiratory bronchioles, Alveoli (300 million),Alveolar ducts and Alveolar sacs.

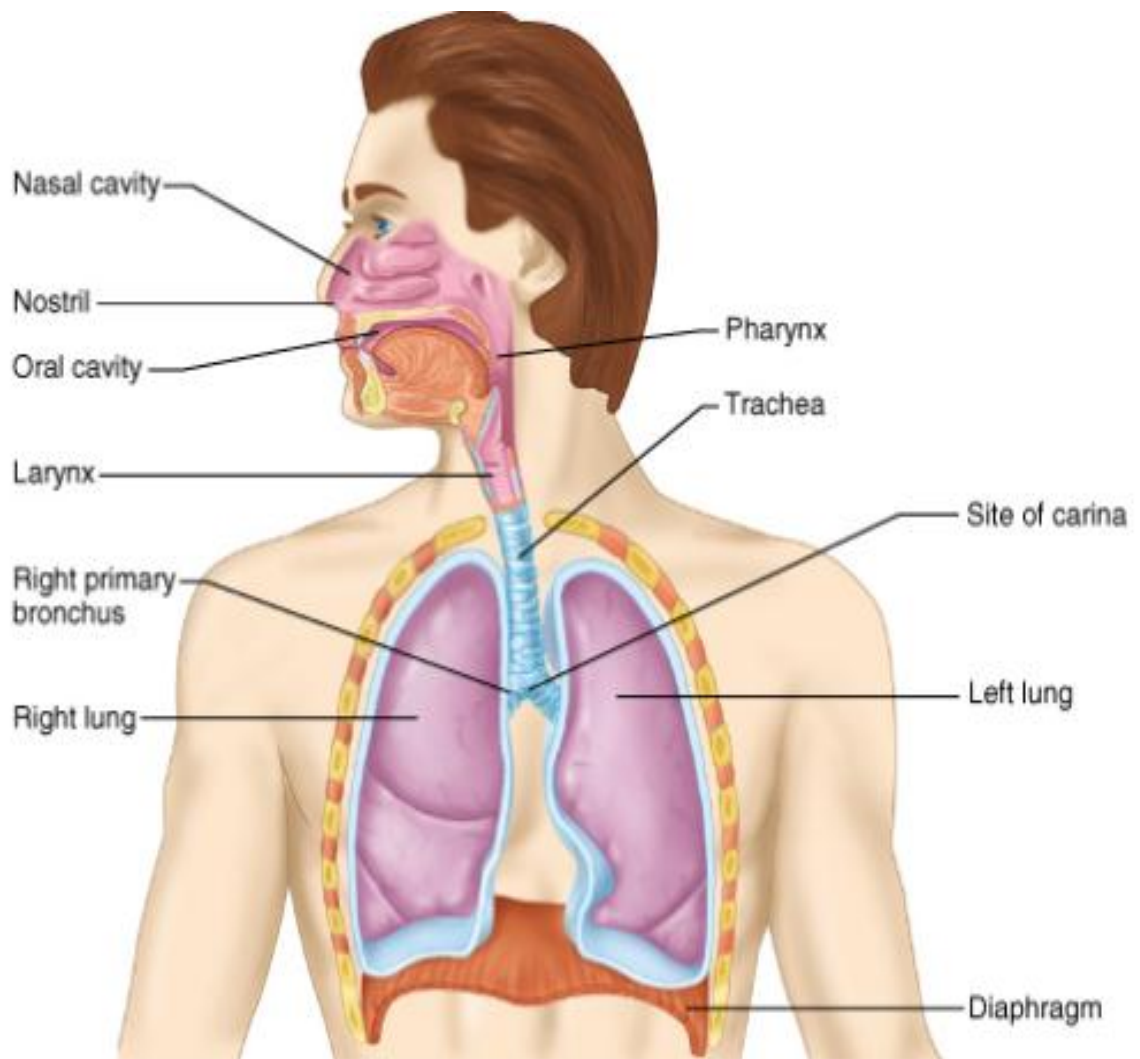

Figure 3-1 Functional Anatomy Of Respiratory System.[7]

3-2 Sleep Apnea

The word apnea means no breathing. Sleep apnea refers to pauses in breathing that occur while you sleep. These pauses in breathing last for 10 to 30 seconds, possibly longer, until the body reacts with a bigger breathing effort to overcome the problem. These pauses are termed events by sleep specialists. This cycle happens over and over throughout the night, interfering with the normal sleep pattern. People with sleep apnea do not feel rested and refreshed in the morning. [8]

3-3Types Of Sleep Apnea

1.Obstructive sleep apnea

It's the most common type of sleep apnea .it occur when the soft tissue in the back of the throat relaxes during sleep ,causing a blockage of the air way(as well as loud snoring).

Obstructive Sleep Apnea (OSA) is a disorder characterized by repetitive collapse and reopening of the upper airway during sleep .The collapse of the air way blocks the flow of air into the lungs(ventilation).

This can result in intermittent reduction of oxygen (hypoxemia) and increase in carbon dioxide(hyper -capnia) in the blood. During collapse of the air ways ,the resistance to air flow result in increased respiratory effort and causing the pressure in the chest cavity(intra thoracic pressure) to change from high to low continuously causing increased work of breathing by respiratory muscles. Eventually ,the increased work of breathing result in disruption of sleep and awaking (arousal) and activation of upper-airway muscles that causes reopening of the air way[8] .

The Obstructive Sleep Apnea Cycle

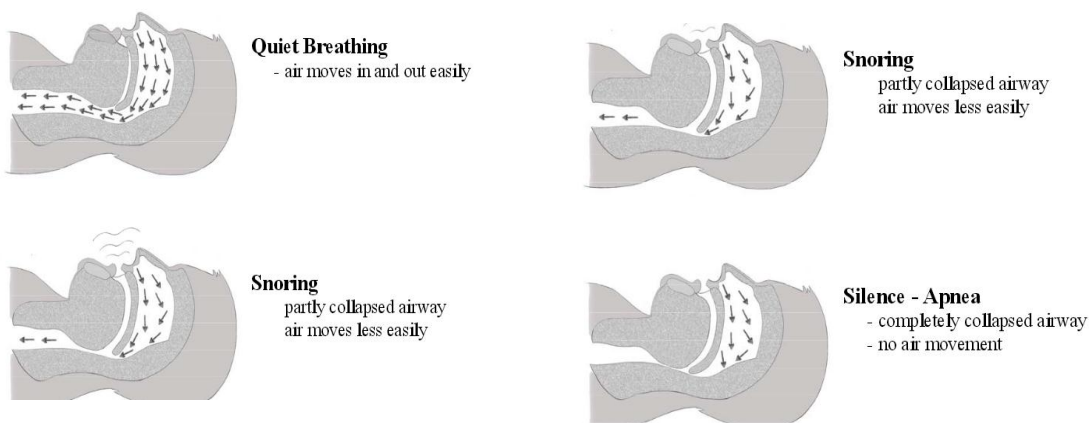

This cycle is repeated over and over, robbing you of restful sleep.

Figure 3-2 cycle of Obstructive Sleep Apnea[8]

2. Central sleep apnea

happens when the brain fails to signal the muscles needed to breathe. It is not as common as obstructive sleep apnea.[8]

3. Mixed or complex sleep apnea

It's a blend of both central and obstructive sleep apnea. Each episode usually begins with no breathing effort (central sleep apnea). The breathing effort then starts, but the airway is blocked (obstructive sleep apnea). [8]

4. Sleep Hypoventilation

It's linked to obesity. Low blood oxygen levels and high Carbon dioxide levels during sleep, as well as during the day, distinguish this type of sleep disordered breathing from others[8]

3-4 Stages of Sleep

All sleep is not equal. It has been subdivided into several stages which help the body's physiology in different ways, these individual stages are characterized by a unique constellation of traits which can be quantified and measured with polysomnography. There are 2 broad categories, namely sleep involving rapid eye movement (REM) and sleep without rapid eye movement (NREM).[9]

The latter is further divided into 3 sub stages

NREM Stage1

This is the transition from the waking world to sleep. It is the stage where the person is not quite awake and not yet asleep. It is characterized on EEG by alpha waves which are the waves which predominate during wakefulness. All muscles are active in this stage of sleep and the eyes are free to move; however, these eye movements differ from those present in REM sleep.[9]

NREM Stage 2

In stage 2 sleep, it becomes more difficult to rouse the sleeper. Alpha waves give way to theta activity whereupon alpha waves are interrupted with sleep spindles and K complexes. These are key findings not present in other forms of sleep and are interesting in their own right.

Sleep spindles coming from the thalamus are theorized to have a relationship with maintaining a tranquil state in the sleeper in the presence of external noise. Additional theories as to their importance includes neural mapping in children while the brain tries to solidify conduction pathways and discover which nerves control which muscle groups. K complexes also aid in suppressing the arousal of the sleeper in response to external stimuli. Additionally K complexes are linked to sleep-based memory consolidation. They are the highest amplitude finding on a healthy human EEG.[9]

NREM Stage 3

This stage was previously divided into stage 3 and 4 and has since been consolidated. Stage 3 is what is referred to as “slow wave sleep” and is predominated by higher amplitude, lower frequency perturbations in the EEG tracing. During this stage of sleep, the majority of external stimuli will produce no physical response within the sleeper.[9]

REM

REM sleep is referred to as paradoxical sleep as this is the stage where the sleeper is the most difficult to awaken; however, the brain activity is the most vigorous. The tracing resembles that of an awake person and oxygen consumption by the brain during this stage of sleep is even higher than that of the wakeful state. A key difference is that the muscles are paralyzed during REM sleep; ensuring that a person thrash during some of the vivid dreams possible during this stage of sleep. This is of

particular importance concerning obstructive sleep apnea as, due to the paralysis of the muscles, mechanical airway obstruction and thus, obstructive sleep apnea is at its worst during this stage of sleep[9].

3-5 Symptoms Of sleep Apnea

3-5-1 The two main symptoms are:

1. Excessive daytime sleepiness that cannot be explained.
2. Snoring with pauses in breathing.[8]

3-5-2 Other frequent symptoms include

1. High blood pressure.
2. Irritability.
3. Gasping or choking during sleep
4. Fatigue.
5. Depression.
6. Lack of concentration.
7. Morning headaches.
8. Memory loss.
9. Impotence .[8]

3-6 Diagnosis Of Sleep Apnea

3-6-1 polysomnography

The best method of diagnosing sleep apnea and other sleep problems is an overnight test in a sleep laboratory. This test is called **polysomnography (PSG)**. You will be connected to wires that monitor breathing and sleeping. A sleep doctor will explain the results and suggest treatment.[8] .

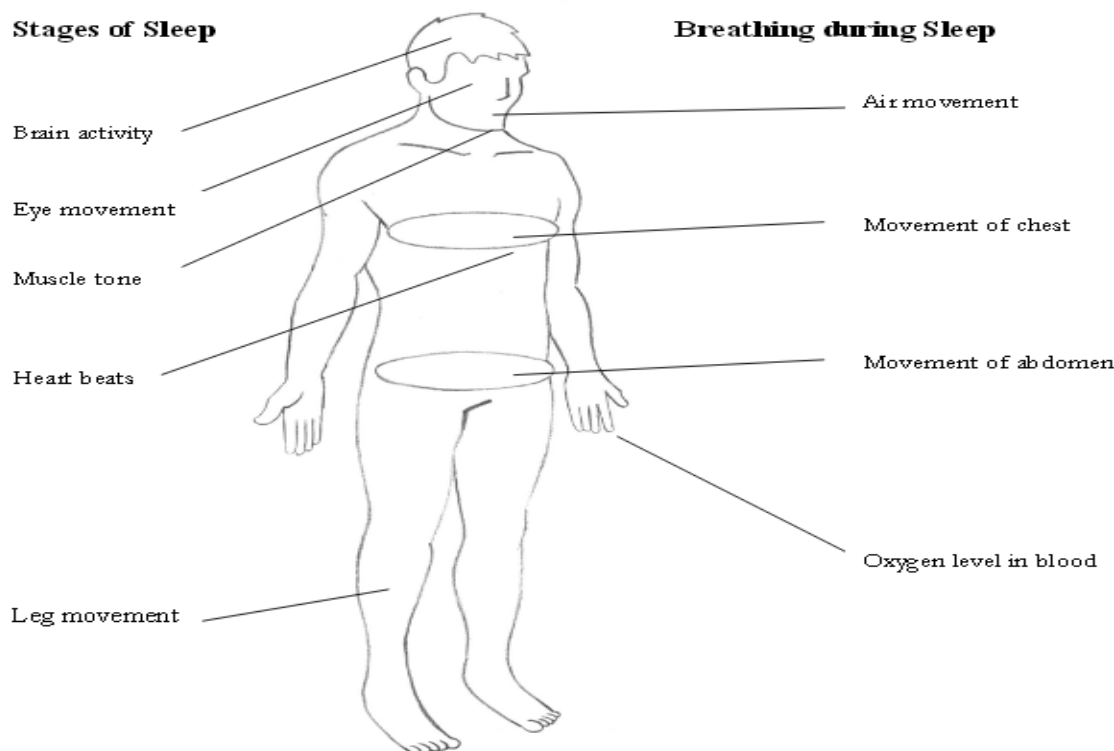

Figure3-3 Polysomnography: an overnight test in the sleep laboratory.

3-6-2 Portable Monitors

As public awareness of sleep apnea grows, so does the demand to be tested. In some areas the waiting time for sleep laboratory testing is very long.

If your doctor believes that your symptoms suggest that you very likely have sleep apnea, and you have no other serious illnesses, portable machines may be used. Portable machines can be used at home and can provide information about oxygen levels, airflow through the nose and mouth, breathing patterns, and snoring. You will be shown how to hook up to the machine so you can do it at home. Testing should be done under the supervision of a physician with training in sleep medicine. If it is discovered that you have sleep apnea, follow-up is needed to decide the best treatment for you. [8].



Portable monitors record information about you while you are sleeping at home in your own bed.

Figure 3-4 portable monitor.[8]

3-7 Treatment

3-7-1 How is Sleep Apnea Treated?

The goal of any treatment for sleep apnea is to prevent airway collapse during sleep.

Over 25 years ago Dr. Collin Sullivan successfully treated a sleep apnea patient with the use of continuous positive airway pressure (CPAP). This was delivered through a mask glued to his nose! Years later, CPAP is still the best treatment for obstructive sleep apnea.[8]

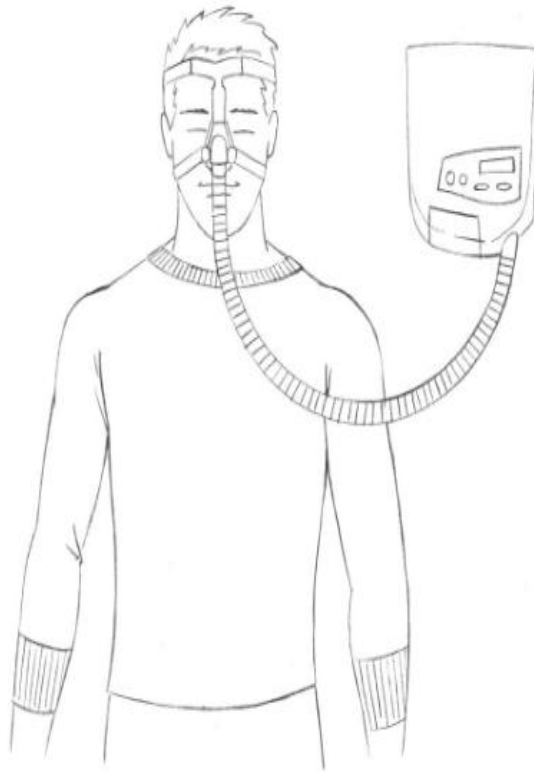
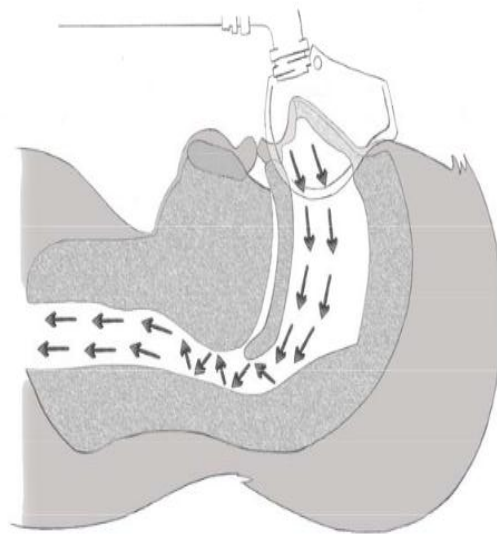

Figure 3-5 CPAP.[8]

3-7-2 How Does CPAP Work?

The CPAP machine delivers a constant flow of air through tubing and a mask to the airway. This creates a ‘splint’ that supports the tissues at the back of the throat, preventing collapse. The amount of pressure developed in the airway by the CPAP machine is prescribed by your sleep specialist, usually after monitoring the effects of treatment during testing at the sleep laboratory. Once your airway is open, the obstructive apnea events and snoring are prevented from happening.[8]



Flow of air from CPAP machine splints the airway.

This prevents collapse.

Your snoring and apnea stop.

Figure 3-6 How CPAP works.[8]

CPAP is a treatment, not a cure. You will feel better only as long as you use it. If you stop using the CPAP, your symptoms will return. We understand that wearing CPAP can be difficult, especially if you still feel tired or cannot sleep with a mask on your face. It is important to work with your doctor and equipment supplier to solve any problems you may have.

CPAP equipment has improved over the years. Smaller, quieter machines, heated humidity, pressure relief and automatic CPAP machines are all newer options. Machines now record information about how the therapy is working[8].

3-7-3Other Sleep Apnea Treatments

CPAP is the first and the most effective treatment choice for sleep apnea.

Other treatments include:

1. Lifestyle

Some people with mild sleep apnea can be treated with lifestyle adjustments such as weight loss and avoiding alcohol and sedatives. You may only have episodes of obstructive sleep apnea while sleeping on your back. In that case, sleep position training may correct the problem. As you get older or if you gain weight, these simple solutions may no longer be effective.[8]

2. Dental Appliances

Your doctor may suggest a dental appliance to treat mild or moderate sleep apnea. The dentist will then prescribe a dental appliance made to fit over your teeth. The appliance is worn at night to hold the tongue and jaw in a forward position. These are available in either a fixed or adjustable type. The adjustable appliance is the preferred choice because it allows for adjustments forward and back, customizing the treatment for you. Dental appliances may also be called oral appliances[8].

3. Surgery

If CPAP therapy has been ruled out as an option for you, there are several types of surgery that may decrease or eliminate the obstructive sleep apnea events. Surgery for sleep apnea is not ‘one size fits all’. The important first step is to determine exactly where the obstruction is occurring in your airway, remembering that several areas may be involved. An ear, nose and throat specialist has the ability to examine your nose, mouth and throat to pinpoint the problem. [8]

The following are a few types of surgery available

1.Tonsillectomy

Large tonsils that are causing a problem with breathing can be surgically removed.

Although there may be complications with any surgery, this is the most effective treatment for patients with sleep apnea who have enlarged tonsils. Children with sleep apnea often benefit from tonsillectomies.

Uvulo palate pharyngo plasty (UPPP).

In this procedure, which doctors call ‘u triple p’, the surgeon cuts away the uvula and part of the soft tissue at the back of the throat. Snoring might improve and sleep apnea events may be reduced. Nasal regurgitation (fluids going up the nose when you swallow), can be a complication. If your sleep apnea is not controlled you may have trouble using CPAP after this surgery.[8]

2.Pillar Procedure

The surgeon freezes the roof of the mouth and inserts three implants into the soft palate. These implants work to stiffen that area making it less floppy so it does not vibrate and cause snoring. This may decrease sleep apnea events if you have mild OSA. This procedure is only recommended for people with a body mass index (BMI) of less than 30, for example, a 6 foot man weighing no more than 225 lbs. This procedure has not been proven, and is considered to be experimental.[8]

3-8 Sleep Lab

3-8-1 Introduction

Sleep lab is a place where patient have his diagnostic and treatment in it, while he sleep for 8 hours for these processes . The technician monitor him from special room then record results.

3-8-2 Polysomnography

Polysomnography (PSG), also known as a sleep study , is a multi-parametric test used in the study of sleep and as a diagnostic tool in sleep

medicine. The test result is called a polysomnogram, also abbreviated PSG. The name is derived from Greek and Latin roots .

Polysomnography is a comprehensive recording of the bio physiological changes that occur during sleep. It is usually performed at night , when most people sleep , though some labs can accommodate shift workers and people with circadian rhythm sleep disorders and do the test at other times of day. The PSG monitors many body functions including brain (EEG), eye movement (EOG), muscle activity or skeletal muscle activation (EMG) and heart rhythm (ECG) during sleep . After the identification of the sleep disorder sleep apnea , the breathing function respiratory airflow and respiratory effort indicators were added along with peripheral pulse oximetry.[8]

4-1 Diagnostic Of Sleep Apnea

Diagnostic process take from 4 to 8 hours, where patient s sleep and sensors connected to him. Monitoring and diagnostic process taken from another room the process called(Radiology) Monitor or control process have a computer that connected to all bio sensors in program called(Radiology),this program show and monitor bio signals of patient then display it on a monitor. Every signal have specific purpose as shown.

4-2 Treatment Of Sleep Apnea

Treatment room differ from diagnosis room in existing of CPAP . CPAP(Continuous Positive Airway Pressure) is a diagnostic device that open throatemphraxis which cause sleep apnea ,then the program monitor bio signal of patient then save and record it before and after using CPAP to show difference and extrapolate the result for treatment.

Technician in controlling room monitor patient until he sleep then begin diagnostic him ,sometimes patent didn't sleep frequently duo to sleep less vigil ,which lead technician to feel tired. Notice that it become dangerous when patient's breath stop more than one minute ,which lead technician to wake up patient.

4-3 Methodology

Micro controller receive breathing signal ,if breath stop (signal value =0) for 10 seconds or more than it ,it calculated as first cut in breathing signal ,and so on.

All that happened in Apnea condition but in Hypo apnea "very under breathing signal result from small opening during closing of specific part of throat(snoring)"it's percentage to normal breathing signal is 30%,and

it didn't calculated as a cut unless the rate of oxygen in blood become less than 3%.



Figure 4-1 diagnostic device of sleep apnea



Figure 4-2 treatment device of sleep apnea



Figure 4-3 Diagnostic And Treatment Room Of Sleep Apnea

4-4 Hard Ware

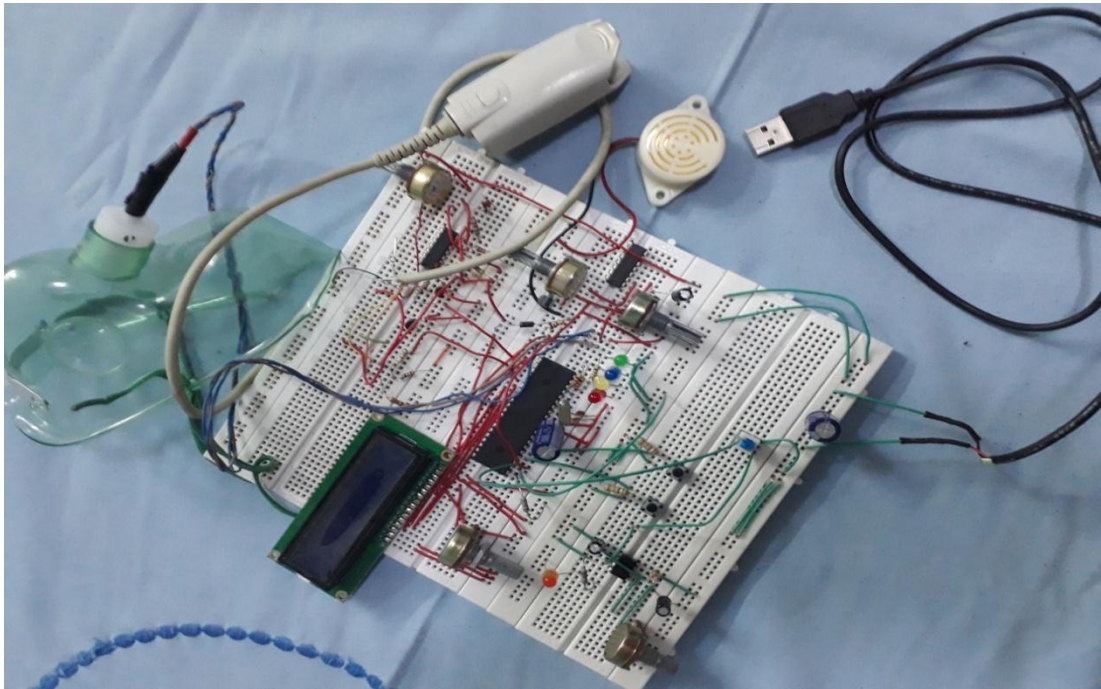

Figure4-4 Hard Ware Circuit

The device consist of many simple and non complicated electronic elements that detect Sleep Apnea and classify condition if it's normal ,mild ,exhausted or severe.

The device process idea that analog signal inputted by sensors .

The two type of bio signals are:

1.Breathing Signal.

2.SPO2 Signal.

Then bio signals to microcontroller that interpret and analysis bio signals ,then give the correct information about if there is Sleep Apnea or not and classification of patient condition

The circuit consist of

Resistor

A resistor as shown in fig 4.1 below is a passive two-terminal electrical component that implements electrical resistance as a circuit element.

Resistors act to reduce current flow, and, at the same time, act to lower voltage levels within circuits. In electronic circuits, resistors are used to limit current flow, to adjust signal levels, bias active elements, and terminate transmission lines among other uses. [9]



Figure 4-5 Resistor. [9]

Capacitor

Ceramic capacitor is a fixed value capacitor in which ceramic material acts as the dielectric. It is constructed of two or more alternating layers of ceramic and a metal layer acting as the electrodes. The composition of the ceramic material defines the electrical behavior and therefore applications. Ceramic capacitors are divided into two application classes:

Class 1 ceramic capacitors offer high stability and low losses for resonant circuit applications. Class 2 ceramic capacitors offer high volumetric efficiency for buffer, by pass, and coupling applications.[10]



Figure 4-6 Ceramic Capacitor. [10]

Diode

The 1N4148 and 1N4448 are high-speed switching diodes fabricated in planar technology, and encapsulated in hermetically sealed leaded glass SOD27 (DO-35) packages.[11]



Figure 4-7 High-Speed Switching Diodes[11]

LED

A light-emitting diode (LED) as shown in fig 4.4. below is a two-lead semiconductor light source. It is a p-n junction diode, which emits light when activated. When a suitable voltage is applied to the leads, electrons are able to recombine with electron holes within the device, releasing energy in the form of photons. This effect is called electroluminescence, and the color of the light (corresponding to the energy of the photon) is determined by the energy band gap of the semiconductor. [12]



Figure 4-8 Light Emitting Diode[12]

Microcontroller pic16f887- device overview

The pic16f887 is one of the latest products from microchip .it features all the components which modern microcontroller normally have .for its low price ,wide range of application ,high quality and easy availability ,it is an ideal solution in applications such as: the control of different processes in industry, machine control devices ,measurement of different value etc[13]



Figure 4-9 Microcontroller Pic16f887.[13]

Crystal

is one of most important aspects of materials science and engineering as many properties of material depend on their crystal structure ,the basic principle of many materials characterization techniques are based on crystallography.[14]

Buzzer

is an integrated structure of electronic transducers ,DC power supply ,widely used in computer ,printers ,copiers ,alarms electronic toys ,automotive electronic equipment ,telephone ,timers and other electronic products for sound devices.

Active buzzer 5V rated power can be directly connected to a continuous sound ,this section dedication sensor expansion module and the board in combination ,can complete a simple circuit design .[15]



Figure 4-10 Buzzer.[15]

LCD(16x2)LM016L

The most commonly used character based LCDs are based on Hitachi's HD44780. controller or other which are compatible with HD44580. We will discuss about character based LCDs, their interfacing with various microcontrollers.

The most commonly used LCDs found in the market today are 1 line 2 line or 4 line LCDs which have only one controller and support at most of 80 characters , where most LCDs with one controller has 14 pins and LCDs with 2 controller has 16 pins . [16]



Figure4-11 LCD(16x2)LM016L.[16]

Op-amp

An operational amplifier is a DC-coupled high-gain electronic voltage amplifier with a differential input and usually a single-ended output.

Operational amplifier had their originals in analog computers ,where they were used to perform mathematical operations in many linear ,non linear, and frequency-dependent circuits.[17]



Figure4-12 Operational Amplifier.[17]

Photodiode

A photodiode is a p-n junction or pin semiconductor device that consumes light energy to generate electric current. It is also sometimes referred as photo-detector, photo-sensor, or light detector.

Photodiodes are specially designed to operate in reverse bias condition. Reverse bias means that the p-side of the photodiode is connected to the negative terminal of the battery and n-side is connected to the positive terminal of the battery.

Photodiode is very sensitive to light so when light or photons falls on the photodiode it easily converts light into electric current. Solar cell is also known as large area photodiode because it converts solar energy or light energy into electric energy. However, solar cell works only at bright light.[18]



Figure4-13 photodiode [18]

Transistor

Transistors make our electronics world go ‘round. They’re critical as a control source in just about every modern circuit. Sometimes you see them, but more-often-than-not they’re hidden deep within the die of an integrated circuit. In this tutorial we’ll introduce you to the basics of the most common transistor around: the bi-polar junction transistor (BJT).

In small, discrete quantities, transistors can be used to create simple electronic switches, digital logic, and signal amplifying circuits. In quantities of thousands, millions, and even billions, transistors are interconnected and embedded into tiny chips to create computer memories, microprocessors, and other complex ICs.[19]

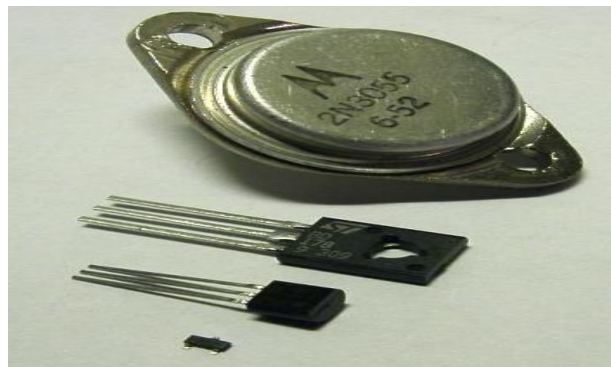

Figure 4-14 Transistor[19]

Breadboard

A breadboard also known as proto-board is a type of solder-less electronic circuit building. You can build an electronic circuit on a breadboard without any soldering. It was designed by Ronald J Portugal of EI Instruments Inc. in 1971. [20]

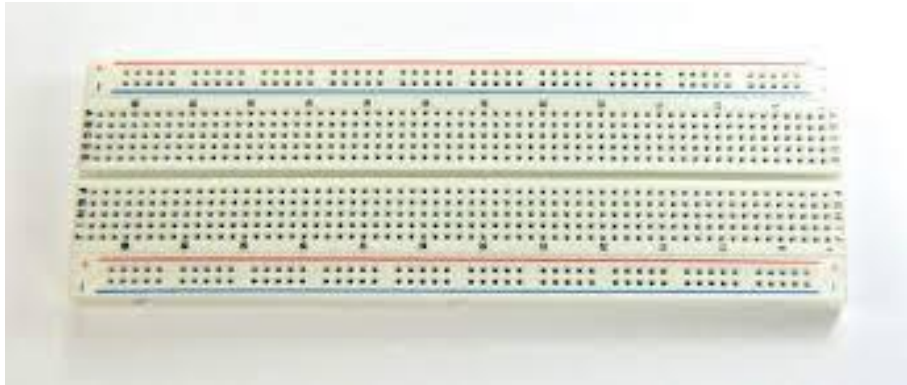

Figure 4-15 Breadboard used is building prototype electronic circuit[20]
Sleep specialists categorize sleep apnea by the number of events per hour

- Normal sleep apnea-0 to 5 events per hour
- Mild sleep apnea – 6 to 20 events per hour
- exhausted sleep apnea – 21 to 39 events per hour
- Severe sleep apnea – over 40 events per hour

4.5 Soft ware

The circuit designed and mimic sleep apnea in a simulation program called "PROTEUS" then we have this results

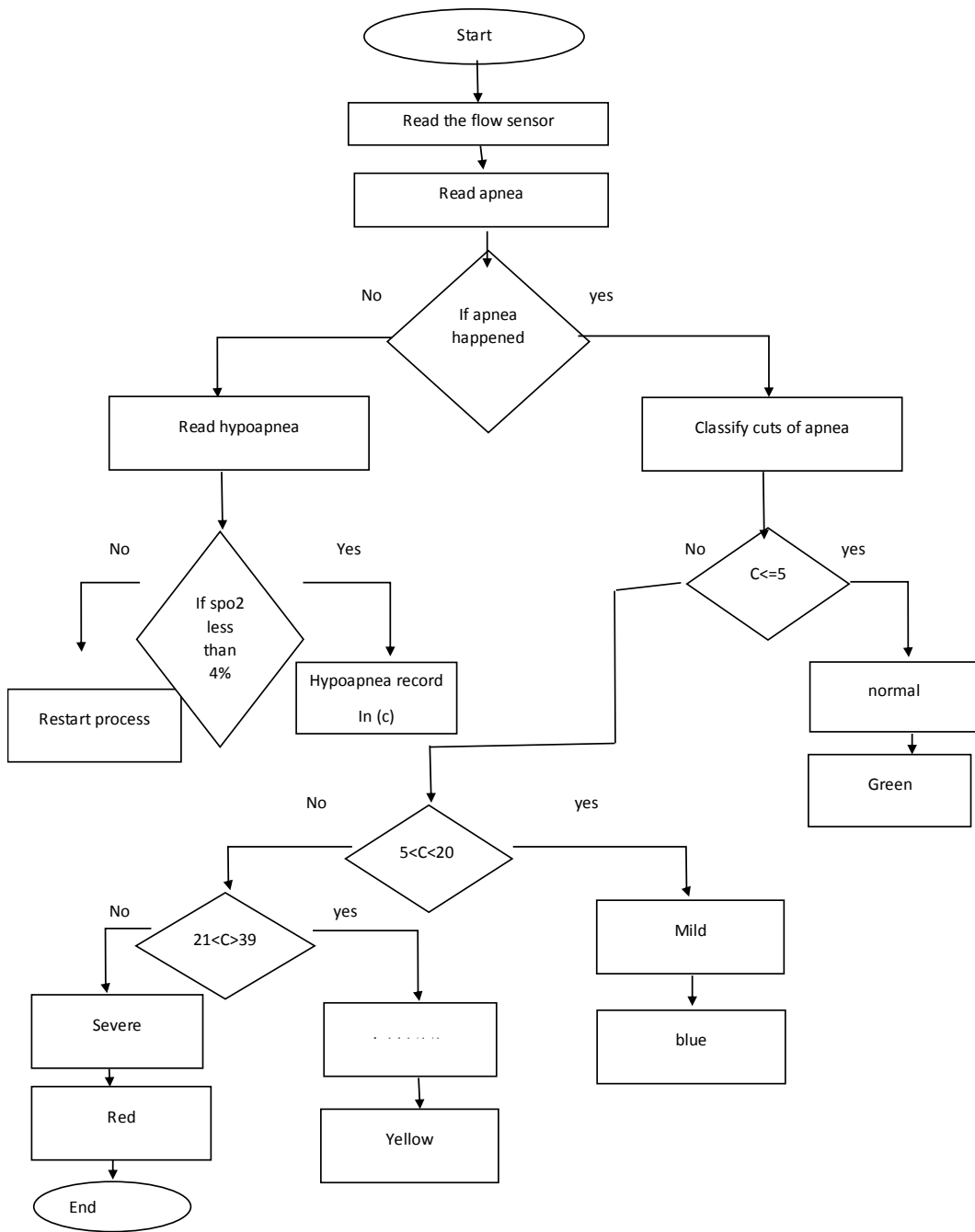

figure4-16 flow chart of project

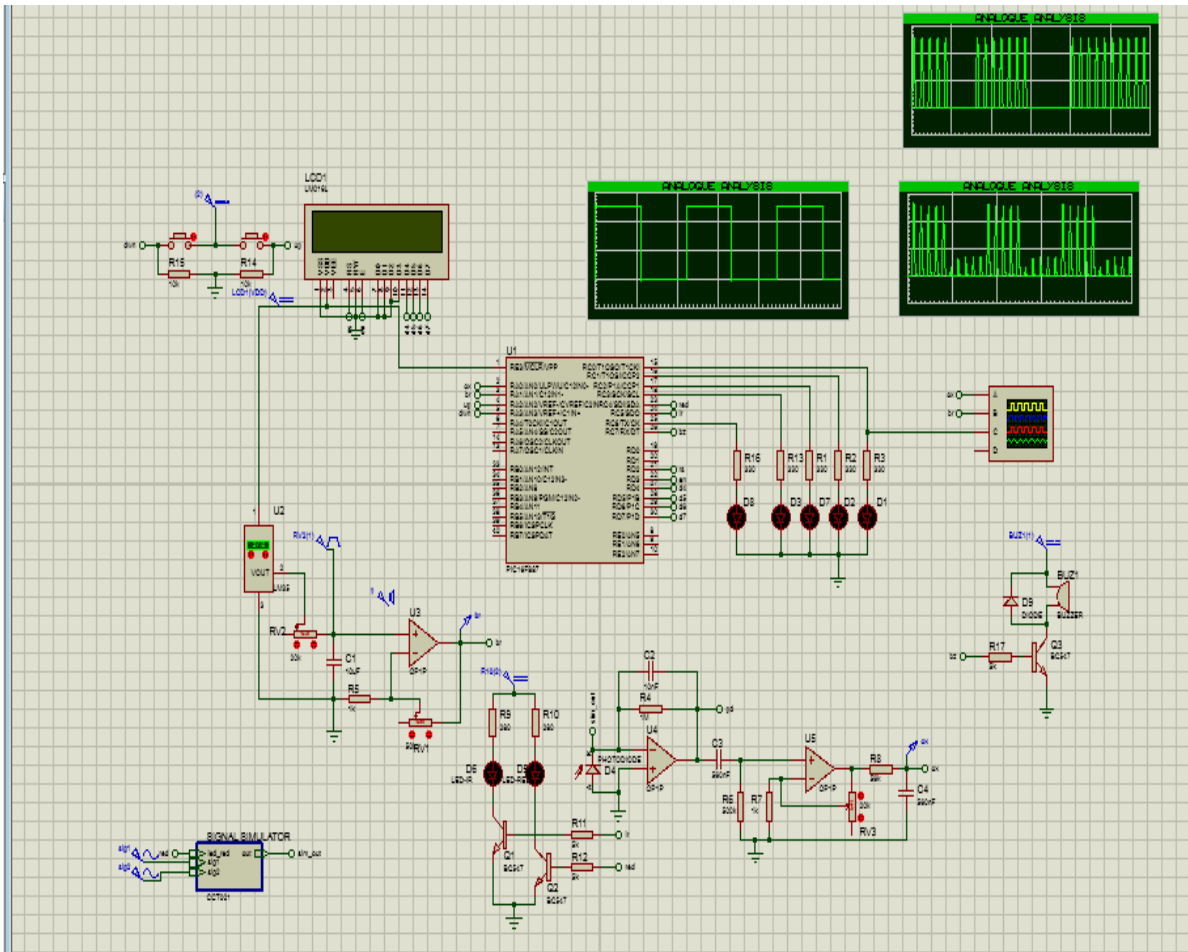

figure 4-17 Simulation of circuit

5-1 Simulation Results

The result (1)



Figure 5-1 result (1) (normal signal)



Figure 5-2 result (1) (apnea)

Discussion (1)

This signal is normal signal with apnea . the circuit detected this apnea .

Result (2)

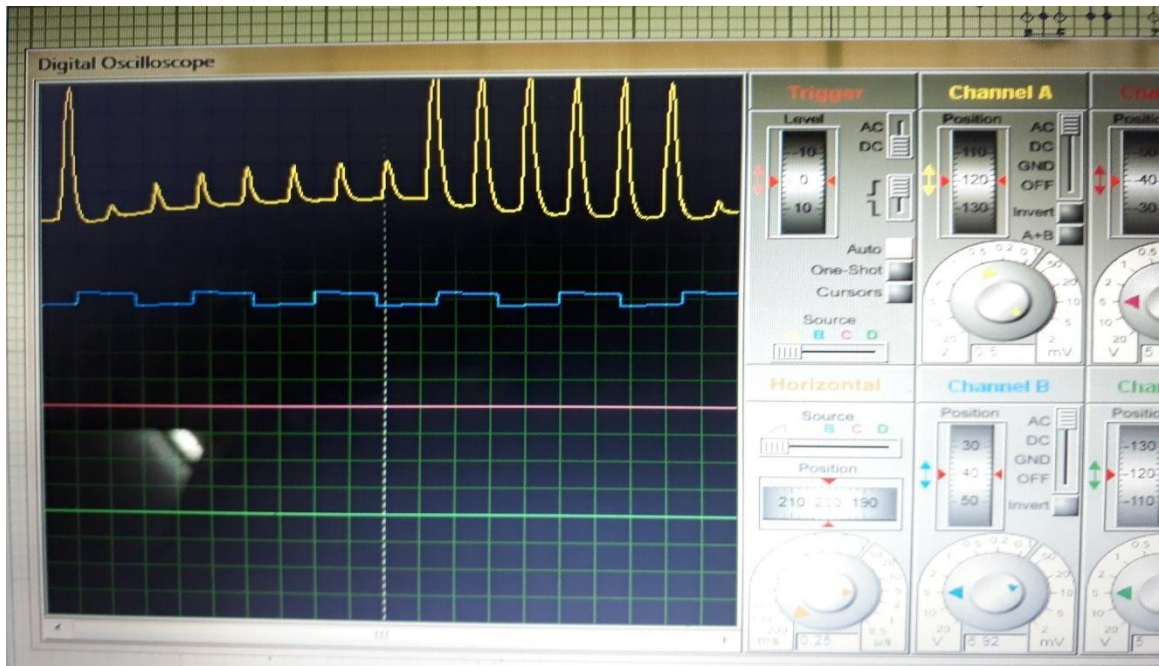

Figure 5-3 result (2)(hypoapnea signal)

Discussion (2)

This signal its like hypoapnea . the circuit detected this abnormal signal (that happened when decrease of oxygen in the blood with 4%) .

Result (3)



. Figure 5-4 result (3)

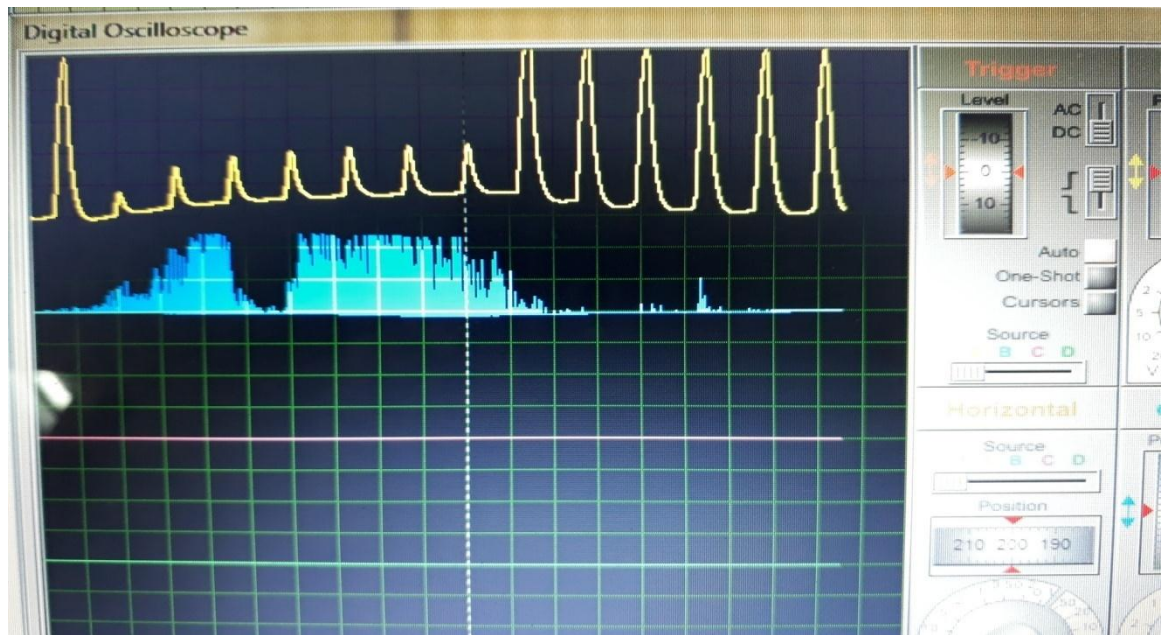

Figure 5-5 result (3)



Figure 5-6 result (3)

Discussion (3)

This is record of respiration with sleep apnea syndrome (noise). The circuit detected this snoring but not all because the microphone (sensor) is sensitive to any noise and the circuit designed to detect voltage signal (LM35).

Result (4)



Figure 5-7 result (4)

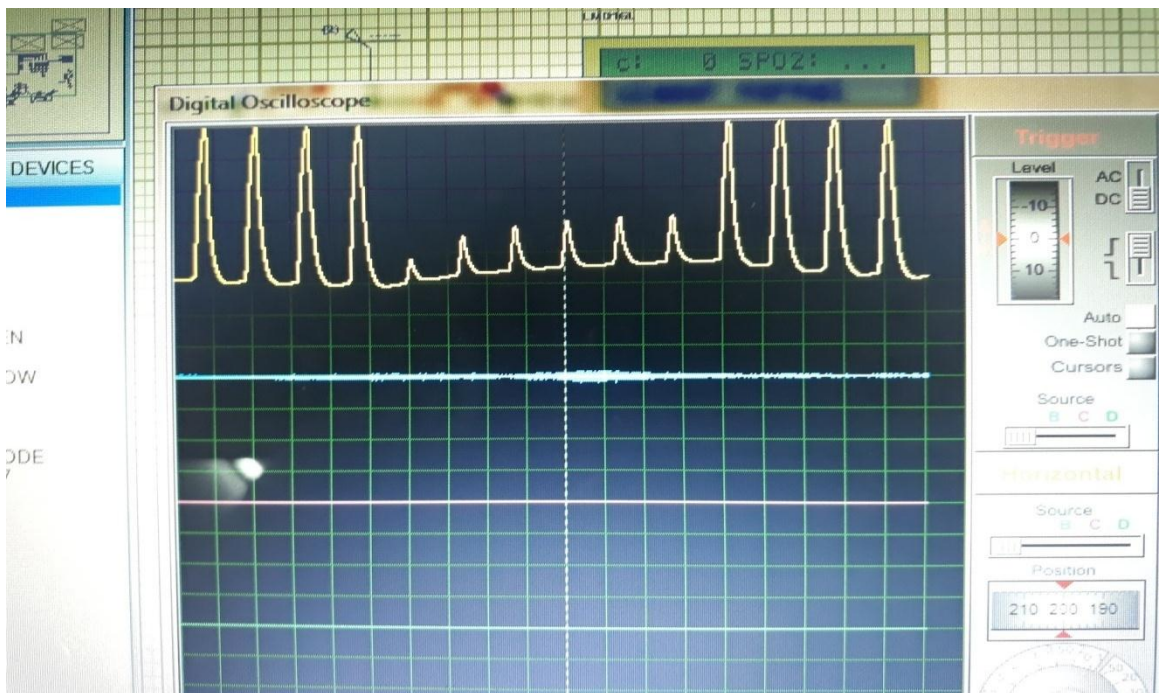

Figure 5-8 result (4)

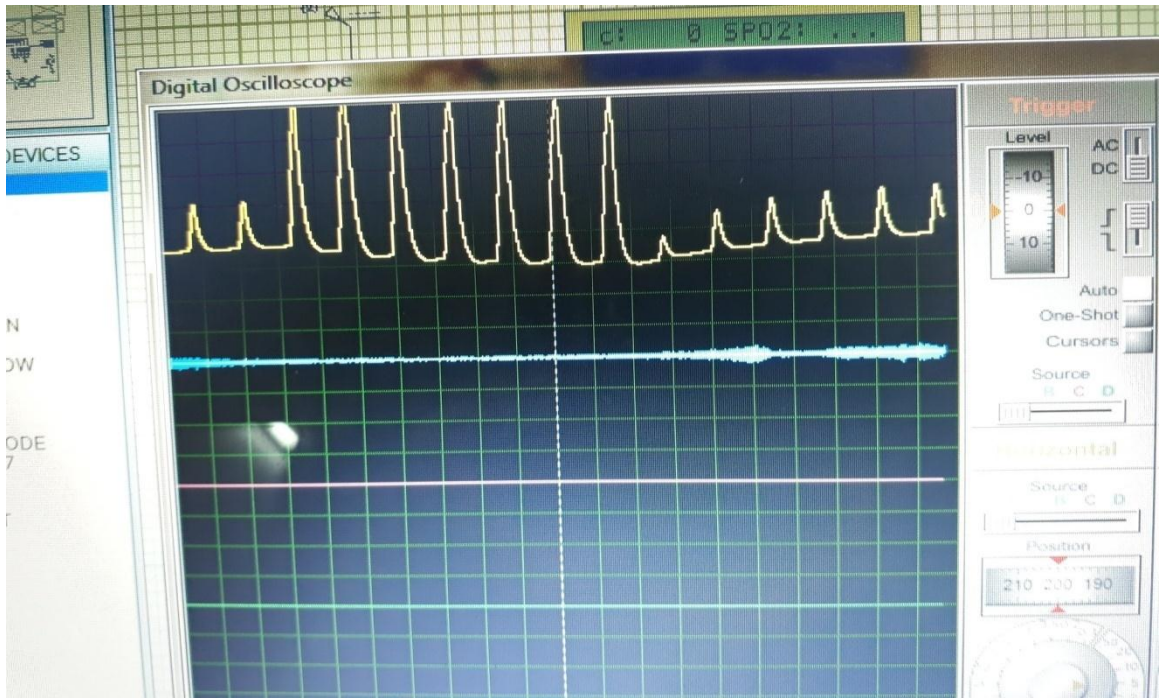

Figure 5-9 result (4)

Discussion (4)

This record referred to child who had sleep apnea syndrome . the circuit detected hypoapnea (that's happened with decrease of SPO2 with 4%)

Result (5)

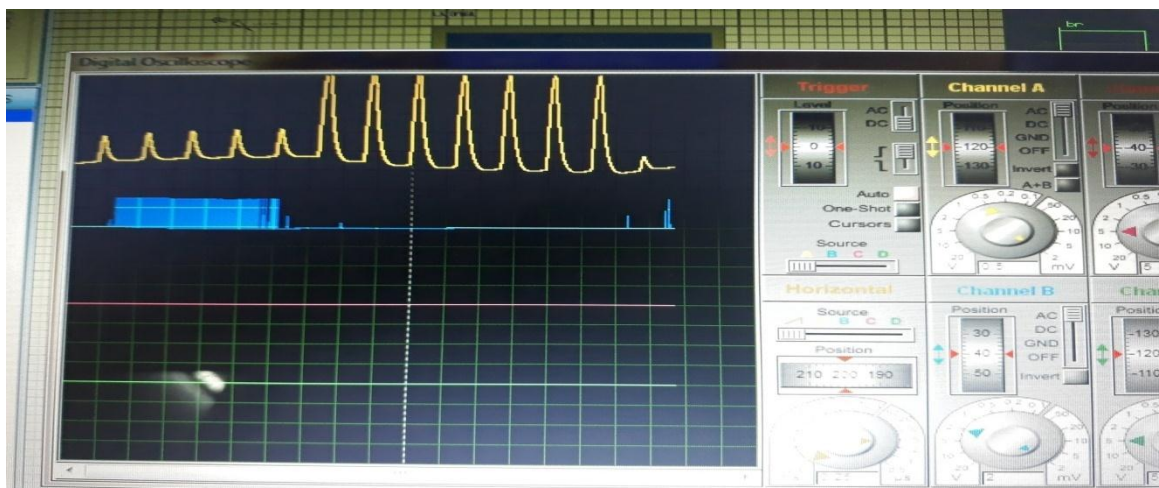

Figure 5-10 result (5)



Figure 5-11 result (5)

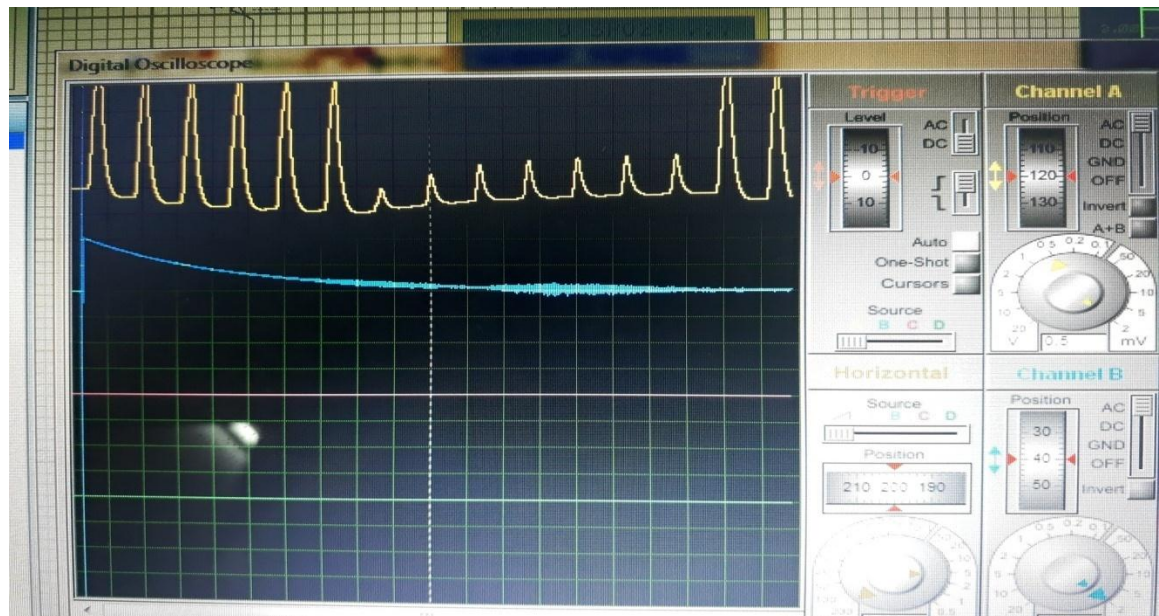

Figure 5-12 result (5)

Discussion (5)

This record referred to woman who had sleep apnea syndrome . the signal contain noise (hypoapnea) when the SPO₂ decrease with 4%. The circuit detected this abnormal signal but not all of it, because the sensitivity of microphone is high ,and the circuit designed for voltage signal (LM35).

6-1 Conclusion

From the previously done the main objective of this project was met, by designing and implementation circuit of obstructive sleep apnea detection, by using two sensors only,(flow and pulse oximeter)

With this project ,its been able to detect and diagnostic sleep apnea by using a low cost electronic circuit .

6-2 Recommendation

The first recommendation is to imprpve the circuit , further more progress toward the output which is ideal signal by using sensor with high efficient .

The second one application in phone which connect with the circuit to receive information of patient to make easier in detection .

References

- [1] Yashar Maali and Adel Al-Jumaily , Genetic Fuzzy Approach based Sleep Apnea/ Hypopnea Detection, . International Journal of Machine Learning and Computing, Vol. 2, No. 5, October 2012.
- [2] Piotr Przystup, Adam Bujnowski, Jacek Rumiński, and Jerzy Wtorek, A Detector of Sleep Disorders for Using at Home. Department of Biomedical Engineering, Gdańsk University of Technology, Gdańsk, Poland , 2014
- [3] Cafer Avci, Gökhan Bilgin- Sleep Apnea Detection Using Adaptive Neuro Fuzzy Inference System , Department of Computer Engineering- Yalova University- Yalova- Turkey , Department of Computer Engineering- Yildiz Technical University- Istanbul , June 2013.
- [4] Agnel John K.J, Pamela .D, ARDUINO UNO BASED OBSTRUCTIVE SLEEP APNEA DETECTION USING RESPIRATORY SIGNAL
M.Tech Embedded Systems- Karunya University , Assistant professo - Karunya University , Mar-2015
- [5] Majdi Bsoul and Lakshman Tamil , Apnea MedAssist: Real-time Sleep Apnea Monitor Using Single-Lead ECG , IEEE TRANSACTIONS ON INFORMATION TECHNOLOGY IN BIOMEDICINE, VOL. 15, NO. 3, MAY 2011.
- [6] <http://www.innerbody.com/anatomy/respiratory>.
- [7] [Reginald H.B ,David S. Archibald D. Morrison ,Chad G. Robertson],<<Obstructive Sleep Apnea Syndrome: Diagnosis and Management >>, Canadian Medical Association, Canada,2014.

- [8] [Michael Fitzpatric], <<SLEEP APNEA HANDBOOK>> , Division of Respiratory & Critical Care Medicine Queen's University, Kingston Ontario , 2012 .
- [9] <http://www.mikroe.com/old/books/keu/01.htm>, accessed October 2015.
- [10]<http://www.powerguru.org/film-capacitors-mkp-types-with-reduced-volume/>
- [11] https://en.wikipedia.org/wiki/Ceramic_capacitor
- [12] [Thomas L],<< Floyd Electronic devices: electron flow version, 9th Ed>>
- [13](pic microcontroller assembly –milan varle-micro Electronic - january 1,2008)
- [14] <http://www.youtube.com/watch?v=qh29mj6uXoM&feature=relmfu>
- [15] [www.eng.utah.edu>handouts>piezo](http://www.eng.utah.edu/handouts/piezo)
- [16]<https://embeddedcenter.wordpress.com>
- [17] [http:// OP AMP modules.com](http://OPAMPmodules.com)
- [18]<http://www.physics-and-radio-electronics.com/electronic-devices-and-circuits/semiconductor-diodes/photodiodesymboltypes.html>
- [19]https://www.google.com/url?sa=t&source=web&rct=j&url=https://learn.sparkfun.com/tutorials/transistors&ved=0ahUKEwjuo_Lv5oDXAhWG2xoKHX6hACQQFgiiATAY&usg=AOvVaw3h0QDKLgZHfa2Z9mjPt9lx
- [20]<http://www.instructables.com/id/How-to-use-a-breadboard>, October 2015