



Sudan University of Science and Technology
College of Engineering
Electronics Engineering



***Adaptive Handover Scheme Enhancement in LTE
Femtocells Network***

*A Research Submitted in Partial fulfillment for the Requirements of the
Degree of B.Sc. (Honors) in Electronics Engineering.*

Prepared By:

- 1. Ashraf AbdElganey Muhmmmed AbdElganey.*
- 2. Muhmmmed Mudawy Muhmmmed Elnour Ali*
- 3. Siddig Sulaiman Sa'eed Omer*
- 4. Tasneem Haroon Mahmoud Yosif*

Supervisor:

Dr. Ashraf QsimElsid Abd Allah

November -2017

الاستهلال

قَالَ تَعَالَى:

﴿ فَفَهَّمْنَاهَا سُلَيْمَانَ ۚ وَكُلًّا ءَايَيْنَا حُكْمًا وَعِلْمًا ۚ وَسَخَّرْنَا مَعَ دَاوُدَ الْجِبَالَ

يُسَبِّحْنَ وَالطَّيْرَ ۚ وَكُنَّا فَاعِلِينَ ﴿٧٩﴾

صدق الله العظيم

سورة الأنبياء الآية (79)

Dedication

We are very grateful to Almighty Allah for helping us through this long journey, May He continues to bless, help and guide us to the right path.

We dedicate this project to all those that helped us toward this success, specially our parents, our families, our teachers and our colleagues.

Thank you all...

Acknowledgements

We would like to express our gratitude and appreciation to all those who gave us the possibility to complete this project. A special thanks to our final year project supervisor **Dr. Ashraf Gsim Elsid AbdAllah**, who help us, stimulating suggestions and encouragement, help gratitude to coordinate our project and writing this report

Abstract

A femtocells are used within Long Term Evolution (LTE) Network to improve the network performance by reducing the blocking. In a large-scale NoF, many UEs may perform cell reselections and handovers to neighboring femtocells frequently. Consequently, this must besolved the scalability problem in terms of location signaling traffic towards the MME in the core network. In Femtocell environments, new and flexible decision parameters will influence the HO other than existing parameters, such as serving cost, user's status and preferences, load balancing, etc. In other words, the serving cell and/or UE should decide to handoff to a target cell based on multiple parameters. There is a need for algorithms to optimize and adapt these and other parameters. Therefore an adaptive handover algorithm is proposed. The algorithm is evaluated by MATLAB simulation. The simulation scenario, includes a group of femtocells in the same administrative domain cooperate towards a global performance improvement, which can effectively manage hotspot cells in 4G Femtocells. The proposed scheme results in increasing the resource utilization, decrease the blocking probability, the transmission dealy time reduced, the package delay reduced and the throughput increased.

المستخلص

الخلايا متناهية الصغر تستخدم في الجيل الرابع لتحسين اداء الشبكة بتقليل انقطاع المكالمات عند المستوى العام .

كثير من اجهزه المستخدمين تقوم بأجراء خيارات متعددة وتحويل المكالمات الي الخلايا المتجاوره المتناهية الصغر باستمرار ولذلك يجب حل مشكلة الاختيارات بمعرفه موقع وكمية الاشاره المرسله من اجهزه ادارة النظام .

الهاتف الجوال في قلب الشبكة في بيئه الخلايا المتناهية الصغر له عوامل متجدده ومرنه وهي التي تؤثر علي القرارات في عملية تحويل المكالمات وذلك يؤدي الي تقليل التكلفة و وحاله المشترك وفضليته وموازنة الحمل علي الشبكة ...

بمعنى اخر يجب ان تكون الخلية التي تقدم الخدمه للمشارك او اجهزة المشارك يجب ان تقرر عملية تحويل المكالمات الي خلية المستهدفه بنائا علي عوامل متعددة ولهذا السبب تم اخراج خوارزميه تحول المكالمات .

لقد تم تقييم اداء الخوارزميه باستخدام برنامج الماتلاب للمحاكاة حيث شمل سيناريو المحاكاه علي مجموعة الخلايا متناهية الصغر في نفس المجال الاداري وذلك يؤدي الي تحسين الاداء العام الذي يدار بصوره فعاله في مناطق الازدحام للجيل الرابع للخلايا متناهية الصغر .

وهذا المقترح ينتج منه زياده في ترشيد الموارد وتقليل احتمالية انقطاع المكالمات ، تقليل تاخير الارسال او تقليل تاخير زمن ارسال الحزمه ، وزياده كفاءة النظام لارسال البيانات.

Table of Contents

الاستهلال	I
Dedication	II
Acknowledgements	III
Abstract	IV
المستخلص.....	v
Abbreviations	XI
1.1. Preface	2
1.2. Problem Statements	4
1.4.Aim and Objective.....	4
1.5.Methodology	5
1.6.Thesis layout	5
2.1 Development of mobile generation.....	8
2.1.1 Requirements and Targets for the Long Term Evolution	9
2.1.2 Cell Throughput and Spectral Efficiency	10
2.1.3 Network Architecture Requirements.....	11
2.2 Technologies for the Long Term Evolution.....	11
2.2.1 Multicarrier Technology.....	12
2.2.2 Multiple Antenna Technology.....	12
2.3 Evolved Universal Terrestrial Radio Access Network (E-UTRAN).....	14
2.4 Network Architecture	16
2.4.1 Non-Access Stratum (NAS) Procedures.....	20
2.4.2 The Access Network.....	21
2.5 The E-UTRAN Network Interfaces.....	21
2.5.1 Control Plane	22

2.5.2	User Plane.....	22
2.6	Radio Resource Management.....	23
2.6.1	Mobility Control in RRC.....	25
2.6.2	Measurement Configuration	26
2.7	Femtocell Definfion.....	29
2.7.1	Benefits of using Femtocells.....	31
2.7.2	Femtocells Challenges and Open Issues.....	32
2.7.3	Networks of Femtocells.....	33
2.7.4	Access Control mechanisms:	34
2.7.5	The Femtocells Evolved Packet System Architecture	35
2.7.6	Handoff Management	39
2.7.7	Deployment Scenarios for Femtocells	40
3.1	Existing Algorithms (Conventional Algorithms).....	47
3.2	The Proposed Algorithm.....	48
3.2.1	Adaptive Handover Time Scheme.....	48
3.2.2	The Algorithm Flow chart	50
3.3	Modelling of the Network	51
3.3.1	Physical Model	52
3.3.2	Mathematical Model of Performance Metrics.....	53
3.4	Simulation model and scenario	58
3.4.1	Simulation Tool	59
Introduction	62
4.1	Resource Utilization	62
4.2	Blocking Probability	63
4.3	Data Rate	64
4.4	Transmission Delay Time	65
4.5	Packet Delay	66

4.6 Throughput 67
Conclusion 70
Future Work and Recommendations 71
References..... 72
Appendices..... 78

LIST OF FIGURES

Figure No	Title	page
2.1.	Frequency-domain view of the LTE multiple-access technologies	12
2.2.	Three fundamental benefits of multiple antennas: (a) diversity gain; (b) array gain; (c) spatial multiplexing gain.	13
2.3.	LTE protocol layers.	15
2.4.	The EPS network elements.	17
2.5.	S1-MME control plane protocol stack. Reproduced by permission of © 3GPP.	22
2.6	S1-U user plane protocol stack. Reproduced by permission of © 3GPP.	23
2.7	Example measurement configuration.	28
2.8	Femtocell Network Overview.	31
2.9	The BeFEMTO Evolved Packet System Architecture.	38
2.10	Scenario 1 with dedicated HeNB-GW.	41
2.11	scenario 2 without HeNB-GW.	43
2.12	scenario 3 with dedicated HeNB-GW in C-Plane only.	44
3.1	Process of adaptive handover time scheme.	50
3.2	FLOW CHART OF ADAPTIVE HANDOVER TIME SCHEME.	51
3.3	Physical load calculation process.	52
4.1	Compare of Resource Utilization for Two Schemes.	63

4.2	Compare Blocking Probability in Adaptive Handover Time Scheme .	64
4.3	Compare Data Rate between Adaptive Handover Time and Conventional Scheme.	65
4.4	Delay Time in Adaptive Handover Time Scheme and in Conventional Scheme.	66
4.5	Comparing Packet Delay between Adaptive Handover Time Scheme.	67
4.6	Throughput for Adaptive Handover Time Scheme and Conventional Scheme.	68

Abbreviations

BeFEMTO	Broadband evolved FEMTO networks
CN	Cognitive Networks
ECM	EPS Connectivity Management
FAP	Femto Access Point
FBS	Femto cell base station
GTP	GPRS Tunneling Protocol
HeNB	Home eNB
HeNB	Management System HeMS
HHM	Hysteresis HO Margin
HM	Hysteresis Margin
LFGW	Local Femto Gateway
LIPA	Local IP Access
LLM	Local Location Management
LNO	Local Network Operator
MME	Mobility Management Entity
MNL	Mobile Network Layer
MNOs	Mobile Network Operators
NCL	Neighbor Cell List
PDCP	Packet Data Convergence Protocol layer
P-GW	The PDN Gateway
RRC	Radio Resource Control
RSRP	Reference Signal Received Power
S1AP	S1 Application Protocol
SCTP	Stream Control Transmission Protocol
SDF	Shortest-Distance-First

S-GW	Serving GeteWay
SIPTO	Selected IP Traffic Offload
SON	Self-organizing Network
SoT	States of Timing
S-rat	(Remote Access Tunnel) interface
TAL	Tracking area list
TB	Transport blocks
TNL	Transport Network Layer
TTT	Time to Trigger
WL	Wireless transmission losses

Chapter One

Introduction

1.1.Preface

The growth in user demand for higher mobile data rates is driving Mobile Network Operators (MNOs) towards the adoption of new solutions in areas such as the Radio Access Network (RAN), the Evolved Packet Core (EPC), and the overall network architecture. In terms of network capacity, out of a million fold increase since 1957, the use of wider spectrum (25x capacity increase), the division of spectrum into smaller resources (5x), and the introduction of advanced modulation schemes (5x) have been much less significant than the improvements in system capacity due to cell size reduction (1600x) [1]. This justifies the interest in femtocells. However, since femtocells are short-range, (often) user deployed Base stations operating in licensed spectrum, there is a need for mechanisms and architectural solutions that minimize the impact on the global system architecture of the MNO.

There has been a significant interest in wireless broadband technologies over the past few years, Most of 3G and 4G networks share similar drawbacks such as the limitation of data capacity of each cell site, and poor indoor coverage. The reason behind poor indoor coverage is that the radio signals, especially at high frequency bands do not penetrate walls well. Currently up to 60% of voice and 70% of data traffic occurs indoors [2], and there is huge growth of data usage in cell phones,the aforementioned factors indicate the need for a solution that remedies the mentioned constraints and limitations.

Femtocell networks are seen as a promising solution for enhanced indoor coverage and increased network capacity, as well as offloading traffic from the Macro/Micro-cells. Perhaps one of the key requirements for

mass deployments and feasibility of Femtocells is mobility management [3].

Mobility Management is a set of tasks for controlling and supervising mobile User terminals or Equipment's (UE) in a wireless network to locate them for delivery services, as well as, to maintain their connections while they are moving. Mobility management is concerned with many aspects, e.g. Quality of Service (QoS), power management, location management, handoff management, and admission control. It is one of the most critical features in wireless communications due to the direct effect on user experience, network performance and power consumption. The two kernel components of mobility management are location management and handoff management [4].

In order to enable femtocells to operate within a variety of networks a standard femtocell network architecture is required. This femtocell network architecture enables a variety of femtocells from different manufacturers to work in the networks of different operators. In this way costs can be reduced by gaining the economies of scale. Also there are greater levels of competition between femtocell manufacturers which also keep the costs under control.

The fundamental requirements for the femtocell network architecture are for the femtocell itself to be located within the users building (although some femtocells may be located externally to provide local coverage in areas where there is no other coverage) [5].

1.2.Problem Statements

In a large-scale NoF, many UEs may perform cell reselections and handovers to neighboring femtocells frequently. Consequently, this must resolve the scalability problem in terms of location signaling traffic towards the MME in the core network. In Femtocell environments, new and flexible decision parameters will influence the HO other than existing parameters, such as serving cost, user's status and preferences, load balancing, etc. In other words, the serving cell and/or UE should decide to handoff to a target cell based on multiple parameters.

1.3.Proposal Solution

There is a need for algorithms to optimize and adapt these and other parameters. The proposed solution is to develop an adaptive algorithm. Then to be evaluated by simulation

1.4.Aim and Objective

This research aims to propose survey the Hand Over decision algorithms, and find the optimum algorithm. Based on some current algorithms, the best parameters will be selected to propose a new HO decision algorithm, and to find out the most Mobility Management approach to give the best performance at the user equipment (UE). The Specific Objectives are as following :

- I. The objective for the autonomous search is to decide when the UE should begin searching for a Femtocell to which it can have access and whether the CSG cell is valid or not.

- II. Analysis and evaluate the new proposed algorithm, simulate it, and analysis the simulation result.
- III. To enhance the handover quality in the LTE femtocells and therefore increasing the overall quality of service, by managing the congested cells using an Adaptive Handover Time Algorithm, which will adaptively control the handoff initiation time according to load status of cells, operation is done by utilizing the resource in both serving and targeted cell to ensure the handoff process handled fast and smoothly.

1.5.Methodology

An adaptive handover algorithm is proposed. The algorithm is evaluated by MATLAB simulation. A physical model consist of three femtocells in one base station. A mathematical model is used to generate the mobility pattern randomly as well as the traffic within the base station cell. The simulation scenario, includes a group of femtocells in the same administrative domain cooperate towards a global performance improvement, which can effectively manage hotspot cells in 4G Femtocells.

1.6.Thesis layout

The following layout shows the present of the material in the research.

Chapter One

Introduction. In this chapter provide an overview of the NoFs concept shows the problem definition, objectives and the methodology.

Chapter Two

includes the terminologies and the LTE technology description. Also it includes the related works.

Chapter Three

Methodology and practical implementation, and to propose newhandover adaptive time-based scheme, which can effectively manage hotspot cells in 4G Femtocells.

Chapter Four

Results. And to present the main traffic and the impact of the proposed algorithm on the network of Femtocells (NoF)

Chapter Five

includes the Conclusion of the study and recommendation for future work.

Chapter Two
literature review

2.1 Development of mobile generation

The Long Term Evolution of UMTS is just one of the latest steps in an advancing series of mobile telecommunications systems. Arguably, at least for land-based systems, the series began in 1947 with the development of the concept of *cells* by the famous Bell Labs of the USA. The use of cells enabled the capacity of a mobile communications network to be increased substantially, by dividing the coverage area up into small cells each with its own base station operating on a different frequency [8].

The need for 3G long-term evolution studies was stated at the end of 2004 within the 3GPP, in order to maintain the competitive position of UMTS-based technologies for the future. It was therefore decided to launch feasibility on overall system architecture and access network evolution, with an objective to finalize core specifications by mid-2007[7]. Over the past few years, fixed Internet access capabilities have been improving, from the 56-Kb/s V90 modem-based access to 10-Mb/s ADSL and 100-Mb/s fiber access, enabling new services and much better user experience. As a consequence, it is not surprising that wireless communication systems are also moving towards increased capabilities and performances, so that the Quality of Service for existing and new services is kept acceptable when used over the radio interface.

Within the 3GPP evolution track, three multiple access technologies are evident: the ‘Second Generation’ GSM/GPRS/EDGE family was based on Time- and Frequency Division Multiple Access (TDMA/FDMA); the ‘Third Generation’ UMTS family marked the entry of Code Division Multiple Access (CDMA) into the 3GPP evolution track, becoming known as *Wideband* CDMA (owing to its 5 MHz carrier bandwidth) or simply

WCDMA; finally LTE has adopted Orthogonal Frequency-Division Multiplexing (OFDM), which is the access technology dominating the latest evolutions of all mobile radio standards.

In continuing the technology progression from the GSM and UMTS technology families within 3GPP, the LTE system can be seen as completing the trend of expansion of service provision beyond voice calls towards a multiservice air interface. This was already a key aim of UMTS and GPRS/EDGE, but LTE was designed from the start with the goal of evolving the radio access technology under the assumption that all services would be packet-switched, rather than following the circuit-switched model of earlier systems. Furthermore, LTE is accompanied by an evolution of the non-radio aspects of the complete system, under the term ‘System Architecture Evolution’ (SAE) which includes the Evolved Packet Core (EPC) network. Together, LTE and SAE comprise the Evolved Packet System (EPS), where both the core network and the radio access are fully packet-switched.

The overall pattern is of an evolution of mobile radio towards flexible, packet-oriented, multiservice systems. The aim of all these systems is towards offering a mobile broadband user experience that can approach that of current fixed access networks such as Asymmetric Digital Subscriber Line (ADSL) and Fiber-To-The-Home (FTTH).

2.1.1 Requirements and Targets for the Long Term Evolution

Discussion of the key requirements for the new LTE system led to the creation of a formal ‘Study Item’ in 3GPP with the specific aim of ‘evolving’ the 3GPP radio access technology to ensure competitiveness

over a 10-year time-frame. Under the auspices of this Study Item, the requirements for LTE were refined and crystallized, being finalized in June 2005. They can be summarized as follows:

- i. Reduced delays, and increased user data rates.
- ii. Increased cell-edge bit-rate, for uniformity of service provision.
- iii. Reduced cost per bit, implying improved spectral efficiency.
- iv. Greater flexibility of spectrum usage, in both new and pre-existing bands.
- v. Simplified network architecture.
- vi. Seamless mobility, including between different radio-access technologies.
- vii. Reasonable power consumption for the mobile terminal.

2.1.2 Cell Throughput and Spectral Efficiency

Performance at the cell level is an important criterion, as it relates directly to the number of cell sites that a network operator requires, and hence to the capital cost of deploying the system. For LTE, it was chosen to assess the cell level performance with full-queue traffic models (i.e. assuming that there is never a shortage of data to transmit if a user is given the opportunity) and a relatively high system load, typically 10 users per cell.

The requirements at the cell level were defined in terms of the following metrics:

- a. Average cell throughput [bps/cell] and spectral efficiency [bps/Hz/cell].

- b. Average user throughput [bps/user] and spectral efficiency [bps/Hz/user].
- c. Cell-edge user throughput [bps/user] and spectral efficiency [bps/Hz/user]. The metric used for this assessment is the 5-percentile user throughput, obtained from the cumulative distribution function of the user throughput.

2.1.3 Network Architecture Requirements

LTE is required to allow a cost-effective deployment by an improved radio access network architecture design including:

- a. Fat architecture consisting of just one type of node, the base station, known in LTE as the eNodeB;
- b. Effective protocols for the support of packet-switched services;
- c. Open interfaces and support of multivendor equipment interoperability;
- d. Efficient mechanisms for operation and maintenance, including self-optimization functionalities;
- e. Support of easy deployment and configuration, for example for so-called home base stations (otherwise known as Femto-cells).

2.2 Technologies for the Long Term Evolution

The fulfilment of the extensive range of requirements outlined above is only possible thanks to advances in the underlying mobile radio technology. As an overview, we outline here three fundamental technologies that have shaped the LTE radio interface design: *multicarrier* technology, *multiple-antenna* technology, and the application of *packet-switching* to the radio

interface. Finally, we summarize the combinations of capabilities that are supported by different categories of LTE mobile terminal.

2.2.1 Multicarrier Technology

Adopting a multicarrier approach for multiple access in LTE was the first major design choice. After initial consolidation of proposals, the candidate schemes for the downlink were Orthogonal Frequency-Division Multiple Access (OFDMA) and Multiple WCDMA, while the candidate schemes for the uplink were Single-Carrier Frequency-Division Multiple Access (SC-FDMA), OFDMA and Multiple WCDMA. The choice of multiple-access schemes was made in December 2005, with OFDMA being selected for the downlink, and SC-FDMA for the uplink. Both of these schemes open up the frequency domain as a new dimension of flexibility in the system, as illustrated schematically in Figure 2.1

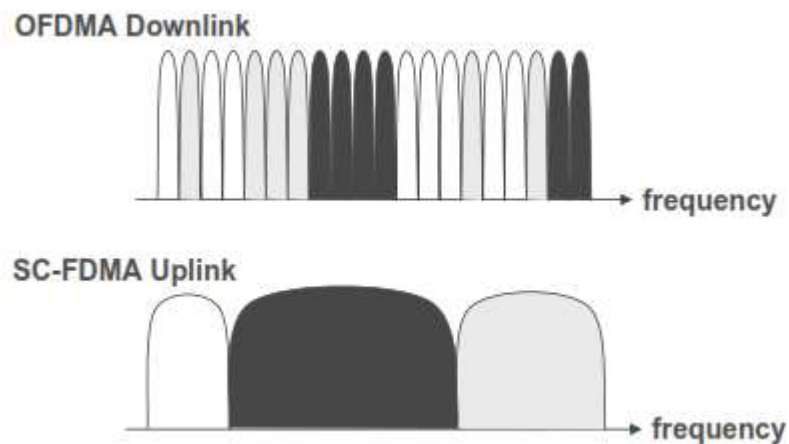

Figure 2. 1: Frequency-domain view of the LTE multiple-access technologies.

2.2.2 Multiple Antenna Technology

The use of multiple antenna technology allows the exploitation of the spatial-domain as another new dimension. This becomes essential in the

quest for higher spectral efficiencies, with the use of multiple antennas the theoretically achievable spectral efficiency scales linearly with the minimum of the number of transmit and receive antennas employed, at least in suitable radio propagation environments.

Multiple antenna technology opens the door to a large variety of features, but not all of them easily deliver their theoretical promises when it comes to implementation in practical systems. Multiple antennas can be used in a variety of ways, mainly based on three fundamental principles, schematically illustrated in Figure 2.2

- **Diversity gain.** Use of the space-diversity provided by the multiple antennas to improve the robustness of the transmission against multipath fading.
- **Array gain.** Concentration of energy in one or more given directions via precoding or beamforming. This also allows multiple users located in different directions to be served simultaneously (so-called multi-user MIMO).
- **Spatial multiplexing gain.** Transmission of multiple signal streams to a single user on multiple spatial layers created by combinations of the available antennas.

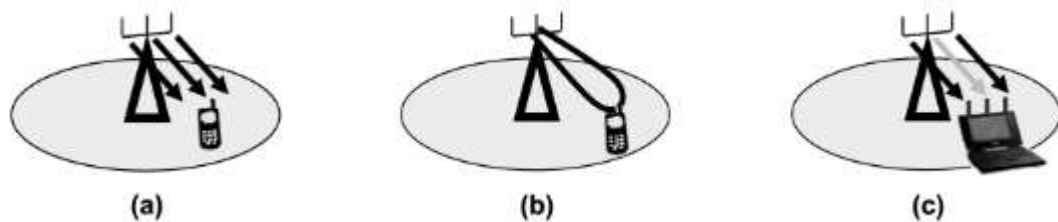

Figure 2. 2: Three fundamental benefits of multiple antennas: (a) diversity gain; (b) array gain; (c) spatial multiplexing gain.

2.3 Evolved Universal Terrestrial Radio Access Network (E-UTRAN)

E-UTRAN is the air interface of 3GPP's Long-Term Evolution (LTE) upgrade path for mobile networks. It is a radio access network standard meant to be a replacement of the UMTS, HSDPA, and HSUPA technologies specified in 3GPP releases 5 and beyond. LTE's E-UTRAN is an entirely new air interface system, which provides higher data rates and lower latency and is optimized for packet data. The E-UTRAN in LTE architecture consists of a single node, i.e., the eNodeB that interfaces with the user equipment (UE). The aim of this simplification is to reduce the latency of all radio interface operations. eNodeBs are connected to each other via the X2 interface, and they connect to the PS core network via the S1 interface.

A general protocol architecture of E-UTRAN (Fig. 2.3) splits the radio interface into three layers: a physical layer or Layer 1, the data link layer (Layer 2), and the network layer or Layer 3. This hierarchical stratification provides a complete vision of the radio interface, from both the functionality associated with each of the structured layer to the protocol flow between them.

The purpose of the protocol stack is to set the services to organize the information to transmit through logical channels whose classifying parameter is the nature of the information they carry (i.e., control or traffic information) and map these logical channels into transport channels whose characteristic is how and with what characteristic the information within each logical channel is transmitted over the radio interface. This how and with what characteristic means that for each transport channel there is one

or more transport formats associated, each of them defined by the encoding, interleaving bit rate, and mapping onto the physical channel. Each layer is characterized by the services provided to the higher layers or entities and the functions that support them as follows:

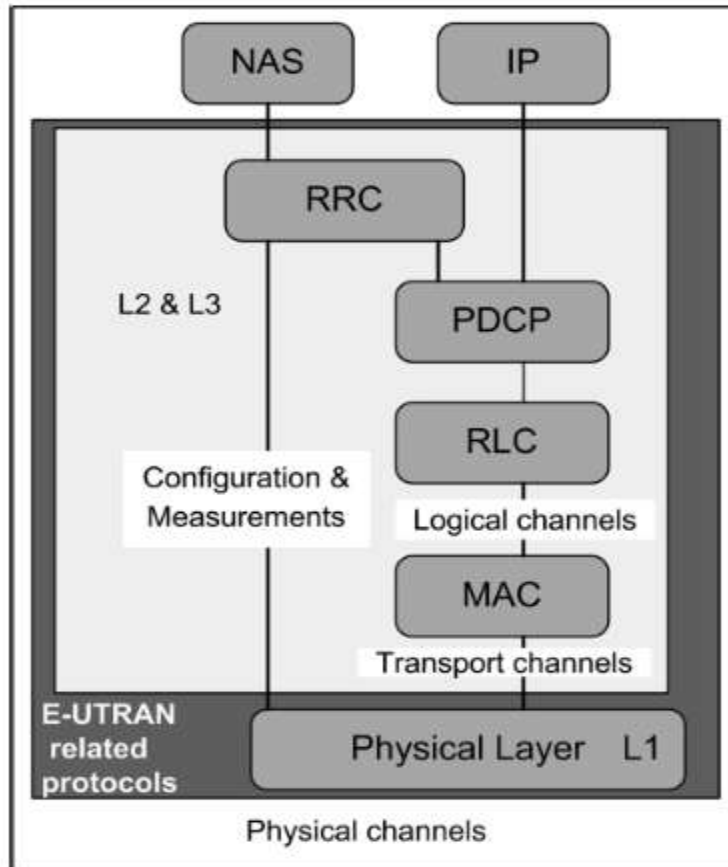

Figure 2. 3: LTE protocol layers

- **Physical layer:** Carries all information from the MAC transport channels over the air interface. Takes care of the link adaptation (AMC), power control, cell search (for initial synchronization and handover purposes), and other measurements (inside the LTE system and between systems) for the RRC layer.
- **MAC:**Medium Access Control.The MAC sublayer offers a set of logical channels to the RLC sublayer that it multiplexes into the physical layer

transport channels. It also manages the HARQ error correction, handles the prioritization of the logical channels for the same UE and the dynamic scheduling between UEs, etc.

- **RLC:**Radio Link Control.It transports the PDCP's PDUs. It can work in three different modes depending on the reliability provided. Depending on this mode it can provideARQ error correction, segmentation/concatenation of PDUs, reordering for in sequence delivery, duplicate detection, etc.

- **PDCP:**Packet Data Convergence Protocol.For the RRC layer it provides transport of its data with ciphering and integrity protection and for the IP layer transport of the IP packets, with ROHC header compression, ciphering, and depending on the RLC mode in-sequence delivery, duplicate detection, and retransmission of its own SDUs during handover.

- **RRC:**Radio Resource Control between others it takes care of the broadcasted system information related to the access stratum and transport of the Non-Access Stratum (NAS) messages, paging, establishment and release of the RRC connection, security key management, handover, UE measurements related to inter-system (inter-RAT) mobility,QoS, etc.

2.4 Network Architecture

LTE has been designed to support only packet switched services, in contrast to the circuit-switched model of previous cellular systems. It aims to provide seamless Internet Protocol (IP) connectivity between User Equipment (UE) and the Packet Data Network (PDN), without any disruption to the end users applications during mobility. While the term 'LTE' encompasses the evolution of the radio access through the Evolved-UTRAN (E-UTRAN), it is accompanied by an evolution of the non-radio aspects under the term 'System Architecture Evolution' (SAE) which

includes the Evolved Packet Core (EPC) network. Together LTE and SAE comprise the Evolved Packet System (EPS). EPS uses the concept of *EPS bearers* to route IP traffic from a gateway in the PDN to the UE. A bearer is an IP packet flow with a defined Quality of Service (QoS) between the gateway and the UE. The E-UTRAN and EPC together set up and release bearers as required by applications.

The core network CN (called EPC in SAE) is responsible for the overall control of the UE and establishment of the bearers. The main logical nodes of the EPC are:

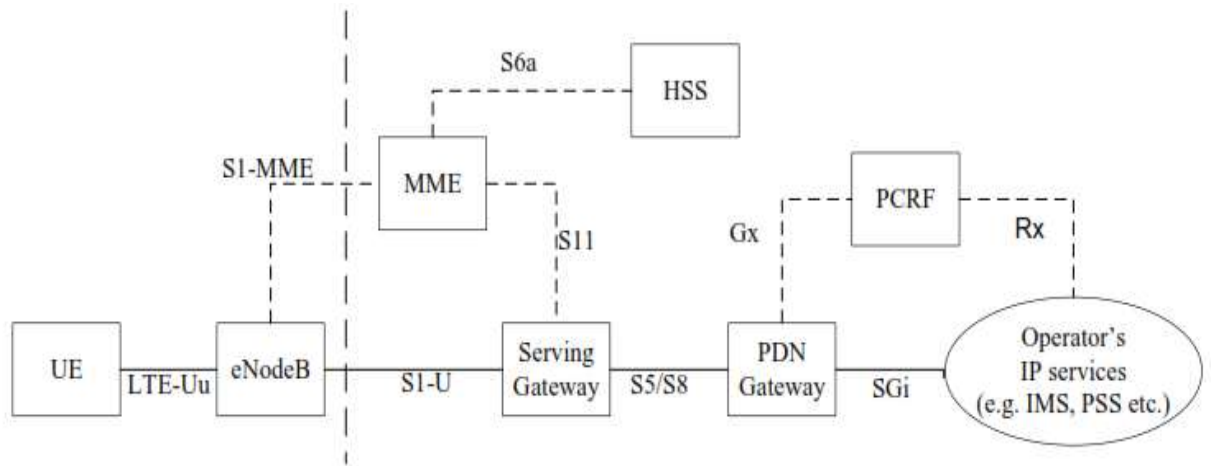

Figure 2. 4: The EPS network elements

- PDN Packet Data Network Gateway (P-GW).
- Serving Gateway (S-GW).
- Mobility Management Entity (MME).

In addition to these nodes, EPC also includes other logical nodes and functions such as the Home Subscriber Server (HSS) and the Policy Control and Charging Rules Function (PCRF). Since the EPS only provides a bearer path of a certain QoS, control of multimedia applications such as VoIP is provided by the IP Multimedia Subsystem (IMS) which is considered to be outside the EPS itself.

The logical CN nodes are shown in Figure 2.4 and discussed in more detail in the following.

- **PCRF.** Policy Control and Charging Rules Function. It is responsible for policy control decision-making, as well as for controlling the flow-based charging functionalities in the Policy Control Enforcement Function (PCEF) which resides in the P-GW. The PCRF provides the QoS authorization (QoS class identifier and bitrates) that decides how a certain data flow will be treated in the PCEF and ensures that this is in accordance with the user's subscription profile.

- **Home Location Register (HLR).** The HLR contains users' SAE subscription data such as the EPS-subscribed QoS profile and any access restrictions for roaming, it also holds information about the PDNs to which the user can connect.

This could be in the form of an Access Point Name (APN) (which is a label according to DNS **Internet** naming conventions describing the access point to the PDN),

or a PDN Address (indicating subscribed IP address. In addition the HLR holds dynamic information such as the identity of the MME to which the user is currently attached or registered. The HLR may also integrate the Authentication Centre (AuC) which generates the vectors for authentication and security keys.

- **P-GW.** The P-GW is responsible for IP address allocation for the UE, as well as QoS enforcement and flow-based charging according to rules from the PCRF. The P-GW is responsible for the filtering of downlink user IP packets into the different QoS based bearers. This is performed based on Traffic Flow Templates (TFTs).

The P-GW performs QoS enforcement for Guaranteed Bit Rate (GBR) bearers. It also serves as the mobility anchor for inter-working with non-3GPP technologies such as CDMA2000 and WiMAX networks.

- **S-GW.** All user IP packets are transferred through the S-GW, which serves as the local mobility anchor for the data bearers when the UE moves between eNodeBs. It also retains the information about the bearers when the UE is in idle state (known as ECMIDLE, and temporarily buffers downlink data while the MME initiates paging of the UE to re-establish the bearers. In addition, the S-GW performs some administrative functions in the visited network such as collecting information for charging (e.g. the volume of data sent to or received from the user), and legal interception. It also serves as the mobility anchor for inter-working with other 3GPP technologies such as GPRS and UMTS.

- **MME.** the MME is the control node which processes the signaling between the UE and the CN. The protocols running between the UE and the CN are known as the *Non-Access Stratum* (NAS) protocols.

The main functions supported by the MME are classified as:

Functions related to bearer management. This includes the establishment, maintenance and release of the bearers, and is handled by the session management layer in the NAS protocol.

Functions related to connection management. This includes the establishment of the connection and security between the network and UE, and is handled by the connection or mobility management layer in the NAS protocol layer.

2.4.1 Non-Access Stratum (NAS) Procedures

The NAS procedures, especially the connection management procedures, are fundamentally similar to UMTS. The main change from UMTS is that EPS allows concatenation of some procedures to allow faster establishment of the connection and the bearers.

The MME creates a UE context when a UE is turned on and attaches to the network. It assigns a unique short temporary identity termed the SAE-Temporary Mobile Subscriber Identity (S-TMSI) to the UE which identifies the UE context in the MME. This UE context holds user subscription information downloaded from the HSS.

To reduce the overhead in the E-UTRAN and processing in the UE, all UE-related information in the access network can be released during long periods of data inactivity. This state is called EPS Connection Management IDLE (ECM-IDLE).

To allow the network to contact an ECM-IDLE UE, the UE updates the network as to its new location whenever it moves out of its current Tracking Area (TA); this procedure is called a 'Tracking Area Update'. The MME is responsible for keeping track of the user location while the UE is in ECM-IDLE.

When there is a need to deliver downlink data to an ECM-IDLE UE, the MME sends a paging message to all the eNodeBs in its current TA, and the eNodeBs page the UE over the radio interface. The MME is responsible for the re-establishment of the radio bearers and updating the UE context in the eNodeB. This transition between the UE states is called an idle-to-active transition. To speed up the idle-to active transition and bearer

establishment, EPS supports concatenation of the NAS and AS procedures for bearer activation.

2.4.2 The Access Network

The Access Network of LTE, E-UTRAN, simply consists of a network of eNodeBs,. For normal user traffic (as opposed to broadcast), there is no centralized controller in E-UTRAN; hence the E-UTRAN architecture is said to be flat. The eNodeBs are normally inter-connected with each other by means of an interface known as X2, and to the EPC by means of the S1 interface – more specifically, to the MME by means of the S1-MME interface and to the S-GW by means of the S1-U interface.

The protocols which run between the eNodeBs and the UE are known as the *Access*

Stratum (AS) protocols. The E-UTRAN is responsible for all radio-related functions are Radio Resource Management, Header Compression, Security and Connectivity to the EPC.

2.5 The E-UTRAN Network Interfaces

The provision of Self-Optimizing Networks (SONs) is one of the key objectives of LTE. Indeed, self-optimization of the network is a high priority for network operators, as a tool to derive the best performance from the network in a cost-effective manner, especially in changing radio propagation environments. Therefore SON has been placed as a cornerstone from the beginning around which all X2 and S1 procedures have been designed.

The S1 interface connects the eNodeB to the EPC. It is split into two interfaces, one for the control plane and the other for the user plane. The

protocol structure for the S1 and the functionality provided over S1 are discussed in more detail below.

2.5.1 Control Plane

Figure 2.5 shows the protocol structure of the S1 control plane which is based on the well-known Stream Control Transmission Protocol / IP (SCTP/IP) stack

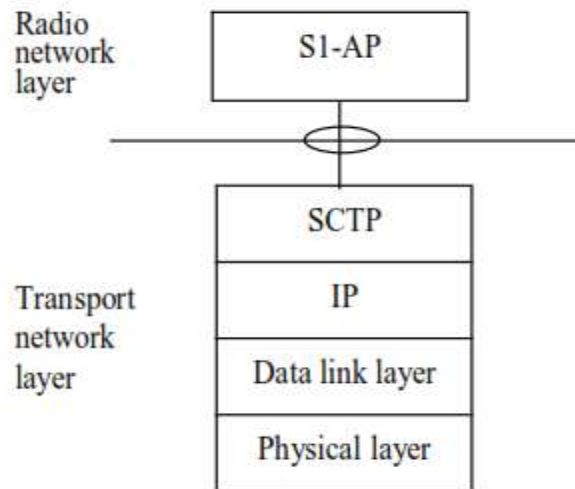

Figure 2. 5: S1-MME control plane protocol stack. Reproduced by permission of © 3GPP.

Stream Control Transmission Protocol, The SCTP protocol is well known for its advanced features inherited from TCP which ensure the required reliable delivery of the signaling messages. In addition it makes it possible to benefit from improved features such as the handling of multistreams to implement transport network redundancy easily and avoid head-of-line blocking or multihoming.

2.5.2 User Plane

Figure 2.6 gives the protocol structure of the S1 user plane, which is based on the GTP/UDP/IP stack which is already well known from UMTS networks. One of the advantages of using GTP-User plane (GTP-U) is its

inherent facility to identify tunnels and also to facilitate intra-3GPP mobility.

A transport bearer is identified by the GTP tunnel endpoints and the IP address (source Tunneling End ID (TEID), destination TEID, source IP address, destination IP address).

The S-GW sends downlink packets of a given bearer to the eNodeB IP address (received in S1-AP) associated to that particular bearer. Similarly, the eNodeB sends upstream packets of a given bearer to the EPC IP address (received in S1-AP) associated to that particular bearer.

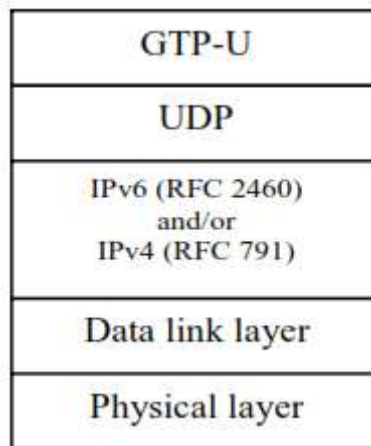

Figure 2. 6: S1-U user plane protocol stack. Reproduced by permission of © 3GPP.

2.6 Radio Resource Management

Radio Resource Management (RRM) in cellular wireless systems aims to provide the user with a mobility experience whereby the User Equipment (UE) and the network take care of managing mobility seamlessly, without the need for any significant user intervention. Unseen to the user, the provision of this functionality often involves additional complexity, both in the system as a whole and in the UE and network equipment. During the design of cellular wireless communication standards

there is an ever-present trade-off between additional UE complexity (e.g. cost, power consumption, and processing power), network complexity (e.g. radio interface resource consumption, network topology) and achievable performance [8].

The main procedures followed by an LTE UE in order to provide support for seamless mobility are cell search, measurements, handover and cell reselection.

The Control Plane of the Access Stratum (AS) handles radio-specific functionality. The AS interacts with the Non-Access Stratum (NAS), which is also referred to as the ‘upper layers’. Among other functions, the NAS control protocols handle Public Land Mobile Network (PLMN) selection, tracking area update, paging, authentication and Evolved Packet System (EPS) bearer establishment, modification and release. The applicable AS-related procedures largely depend on the Radio Resource Control (RRC) state of the User Equipment (UE), which is either RRC_IDLE or RRC_CONNECTED.

A UE in RRC_IDLE performs cell selection and reselection – in other words, it decides on which cell to camp. The cell (re)selection process takes into account the priority of each applicable frequency of each applicable Radio Access Technology (RAT), the radio link quality and the cell status (i.e. whether a cell is barred or reserved). An RRC_IDLE UE monitors a paging channel to detect incoming calls, and also acquires system information. The system information mainly consists of parameters by which the network (E-UTRAN) can control the cell (re)selection process.

In RRC_CONNECTED, the E-UTRAN allocates radio resources to the UE to facilitate the transfer of (unicast) data via shared data channels. To support this operation, the UE monitors an associated control channel

which is used to indicate the dynamic allocation of the shared transmission resources in time and frequency. The UE provides the network with reports of its buffer status and of the downlink channel quality, as well as neighboring cell measurement information to enable E-UTRAN to select the most appropriate cell for the UE. These measurement reports include cells using other frequencies or RATs. The UE also receives system information, consisting mainly of information required to use the transmission channels. To extend its battery lifetime, a UE in RRC_CONNECTED may be configured with a Discontinuous Reception (DRX) cycle.

2.6.1 Mobility Control in RRC

Mobility control in RRC_IDLE is UE-controlled (cell-reselection), while in RRC_CONNECTED it is controlled by the E-UTRAN (handover). However, the mechanisms used in the two states need to be consistent so as to avoid ping-pong between cells upon state transitions. The mobility mechanisms are designed to support a wide variety of scenarios including network sharing, country borders, home deployment and varying cell ranges and subscriber densities.

- **Mobility in idle mode**

In RRC_IDLE, cell re-selection between frequencies is based on absolute priorities, where each frequency has an associated priority. Cell-specific default values of the priorities are provided via system information. In addition, E-UTRAN may assign UE-specific values upon connection release, taking into account factors such as UE capability or subscriber type. In case equal priorities are assigned to multiple cells, the cells are

ranked based on radio link quality. Equal priorities are not applicable between frequencies of different RATs. The UE does not consider frequencies for which it does not have an associated priority; this is useful in situations such as when a neighboring frequency is applicable only for UEs of one of the sharing networks.

- **Mobility in connected mode**

In RRC_CONNECTED, the E-UTRAN decides to which cell a UE should hand over in order to maintain the radio link. As with RRC_IDLE, EUTRAN may take into account not only the radio link quality but also factors such as UE capability, subscriber type and access restrictions. Although E-UTRAN may trigger handover without measurement information (blind handover), normally it configures the UE to report measurements of the candidate target cells. In LTE the UE always connects to a single cell only, in other words the switching of a UE's connection from a source cell to a target cell is a *hard* handover. The hard handover process is normally a 'backward' one, whereby the eNodeB which controls the source cell requests the target eNodeB to prepare for the handover. The target eNodeB subsequently generates the RRC message to order the UE to perform the handover, and the message is transparently forwarded by the source eNodeB to the UE. LTE also supports a kind of 'forward' handover, in which the UE by itself decides to connect to the target cell, where it then requests that the connection be continued.

2.6.2 Measurement Configuration

The E-UTRAN can configure the UE to report measurement information to support the control of UE mobility. The following

measurement configuration elements can be signaled via the RRC Connection Reconfiguration message.

Measurement objects. A measurement object defines on what the UE should perform the measurements such as a carrier frequency. The measurement object may include a list of cells to be considered (white-list or black-list) as well as associated parameters, e.g. frequency- or cell-specific offsets.

Reporting configurations. A reporting configuration consists of the (periodic or event-triggered) criteria which cause the UE to send a measurement report, as well as the details of what information the UE is expected to report (e.g. the quantities, such as Reference Signal Received Power (RSRP), and the number of cells).

Measurement identities. These identify a measurement and define the applicable measurement object and reporting configuration.

Quantity configurations. The quantity configuration defines the filtering to be used on each measurement.

Measurement gaps. Measurement gaps define time periods when no uplink or downlink transmissions will be scheduled, so that the UE may perform the measurements. The measurement gaps are common for all gap-assisted measurements.

- **Measurement Report Triggering**

Depending on the measurement type, the UE may measure and report any of the following:

- The serving cell.

- Listed cells (i.e. cells indicated as part of the measurement object).
- Detected cells on a listed frequency (i.e. cells which are not listed cells but are detected by the UE).

For some RATs, the UE measures and reports listed cells only (i.e. the list is a white-list), while for other RATs the UE also reports detected cells. For LTE, the following event-triggered reporting criteria as in figure 2.7 ,and are specified:

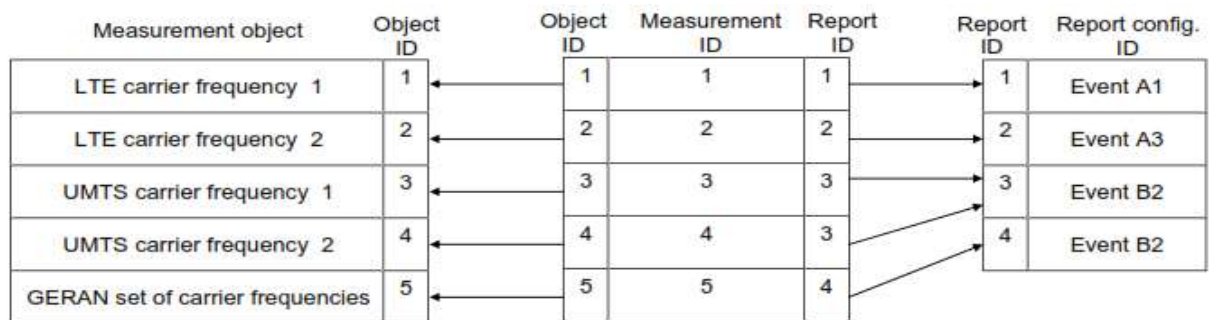

Figure 2. 7: Example measurement configuration.

- **Event A1.** Serving cell becomes better than absolute threshold.
- **Event A2.** Serving cell becomes worse than absolute threshold.
- **Event A3.** Neighbor cell becomes better than an offset relative to the serving cell.
- **Event A4.** Neighbor cell becomes better than absolute threshold.
- **Event A5.** Serving cell becomes worse than one absolute threshold and neighbor cell becomes better than another absolute threshold.

For inter-RAT mobility, the following event-triggered reporting criteria are specified:

- **Event B1.** Neighbor cell becomes better than absolute threshold.

- **Event B2.** Serving cell becomes worse than one absolute threshold and neighbor cell becomes better than another absolute threshold.

The UE may be configured to provide a number of periodic reports after having triggered an event. This ‘event-triggered periodic reporting’ is configured by means of parameters ‘report Amount’ and ‘report Interval’, which specify respectively the number of periodic reports and the time period between them. If event-triggered periodic reporting is configured, the UE’s count of the number of reports sent is reset to zero whenever a new cell meets the entry condition. The same cell cannot then trigger a new set of periodic reports unless it first meets a specified ‘leaving condition’.

2.7 Femtocell Definition

With the macro cellular network, it is not only intricate for the operators to grant high-quality services and cell coverage for the indoor users, but it’s also highly impossible for them to install a large number of outdoor base stations in heavily populated areas for the purpose of increasing indoor coverage. In order to overcome these aforesaid problems femtocells play a vital role as very useful indoor solution.

A Femtocell is a cell in a cellular network that provides radio coverage and is served by a Femto-BS (FBS) FBS also known as a Home-BS or a Femto-Access Point (FAP), is a mini low-power BS installed by end users. FBSs are typically deployed indoors residential, Small Office Home Office (SOHO) and enterprise to offer better coverage, especially where access would otherwise be limited or unavailable. FBSs also offer enhanced data capacity and offload traffic from the Macro/Micro networks. FBSs look like broadband modems, and some FBS manufacturers offer a choice of all in

one box (DSL modem, Wi-Fi router, and FBS). Femtocells operate in the licensed spectrum, and basically have tens of meters of coverage range and can support up to ten active users in a residential setting. FBSs connect to standard cellular phones and similar devices through their wireless interfaces (LTE, WiMAX, and HSDPA+). Traffic is then routed to the cellular operator's network via broadband connection (e.g. xDSL, cable) as shown in Figure (2.8) [3].

Allocation of the available spectrum in Femtocell deployments can be one of following:

Dedicated Spectrum: In this approach, different frequencies are assigned for Femtocells and Macro/Micro-cells.

Partial Co-Channel: In this approach, Macro/Micro-cells and Femtocells share some spectrum and the rest of the spectrum is reserved for Macro/Micro-cells only.

Shared Spectrum: In this approach, Macro/Micro-cells and Femtocells share all available spectrum.

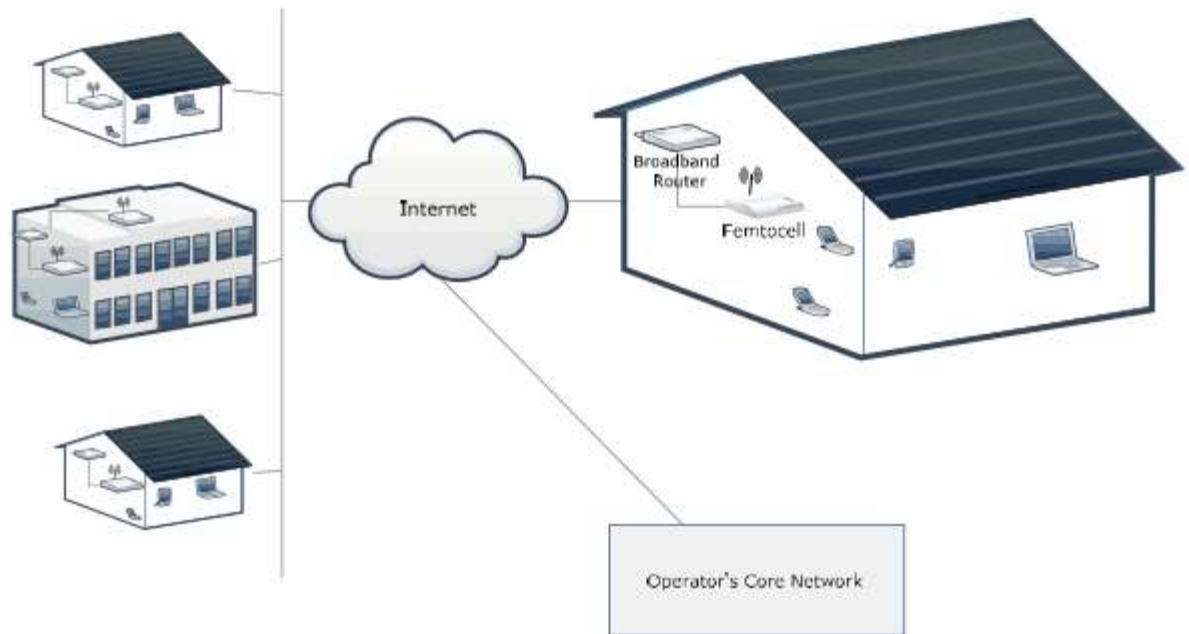

Figure 2. 8: Femtocell Network Overview

2.7.1 Benefits of using Femtocells

There are many potential benefits from the deployment of Femtocells. These benefits are summarized below:

- i. Improved indoor coverage for both data and voice services.
- ii. Improved data rate capacity, because femtocell utilize the user's high data rate broadband connection as its backhaul.
- iii. Reduced power consumption for UEs due to the lower transmit power of FBS when compare to Macro/Micro-BSs.
- iv. Ability to offer new services, e.g., Home Gateway, Connected Home, location based services.
- v. Simple deployment, as femtocell works as a "plug-and-play" device.
- vi. No need for new expensive dual mode UEs, as current UEs work with Femtocells.

- vii. Reduced capital expenditures, since no new expensive Macro/Micro-BSs are needed.
- viii. Lower operational expenditures, because no new cell site, cell site backhaul, and Maintenance are needed.
- ix. Increased mobile usage indoors due to the low-cost fare, hence increasing the Average Revenue per User (ARPU).

2.7.2 Femtocells Challenges and Open Issues

Despite many benefits and advantages of Femtocell networks, they also come with their own issues and challenges. These issues and challenges need to be addressed for successful mass deployment of Femtocell networks. The most relevant issues include:

- I. **Interference:** unplanned deployment of a large number of FBSs introduces interference issues for the mobile networks. Frequency interference is one of the most important issues that impair Femtocell deployment. Frequency interference in Femtocells includes: Cross-tier and Co-tier interference. In Cross-tier interference, a Femto cell base station (FBS) interferes with Micro/Macro-BS or vice versa. In Co-tier interference, a FBS interferes with another neighboring FBS or FBS user.
- II. **Security and QoS:** since FBSs use non-dedicated fixed broadband connections (i.e. xDSL) that carry Femto and non-Femto traffic, managing and controlling voice/data priority and security over third party becomes more difficult.
- III. **Integration of FBS into the CN:** traffic between FBS and the CN send/receive through broadband networks, so it is

important to decide how FBSs integrate with CN, with or without gateways; and what interface they need to connect FBS with CN, or there might a need to upgrade the CN (Software/Hardware) to be connected to Femto-GW. Many possible configurations are available.

IV. **Self Organization Network (SON) and Auto Configurations:** FBS as a Consumer Premise Equipment (CPE) are deployed as plug-and-play devices, so it shall integrate itself into the mobile network without user intervention. Hence, different SON and auto configuration algorithms and techniques are needed.

V. **Mobility and Handoff Management:** considering that FBSs will be deployed densely and by the millions, and may not be accessible to all users, mobility management in Femtocell Networks (such as searching for FBS, Handoff from/to Macro/Micro-BS, access control) becomes one of the most challenging issues [3].

2.7.3 Networks of Femtocells

A NoF is a group of femtocells connected via a local network (wired or wirelessly) and typically belonging to the same administrative domain. They perform functions like radio resource and mobility management cooperatively and mainly by means of local communication, i.e., minimizing the involvement of the mobile core network (EPC, in 3GPP terminology). As opposed to the traditional concept of standalone femtocells, where each small cell acts in an uncoordinated way, NoFs aim at optimizing global network performance by allowing cooperation between

femtocells in a self-organizing (SON) fashion. In this way, NoFs can also be seen as a quickly deployable and cost effective complement to traditional macrocell-based deployments [6]

NoFs are conceived as a complementary solution to existing macro cell deployments in order to improve network coverage and capacity, offload traffic from the EPC, and provide new services to mobile subscribers. A NoF can be defined as a group of femtocells that are able to form a partially autonomous network under the administration of a Local Network Operator (LNO) different from the MNO. In a NoF, base stations feature self-organizing (SON) capabilities, hence collaborating with each other to optimize the global operation of the cellular network. Examples of application scenarios are large-scale outdoor urban deployments, shopping malls, corporate environments, convention centers, or university campuses.

Key to this network is the introduction of an entity called Local Femto Gateway (LFGW) and the modifications in the femtocells in the local network. This allows offloading a high volume of control and data traffic from the core network of the mobile operator to the functional entities in the NoFs.

2.7.4 Access Control mechanisms:

Access Control is based on a HeNB cell ID, which is called Closed Subscriber Group (CSG) identification (CGI). Release 8 defines basic CSG provisioning and access control. The User Equipment (UE) will need to support Automatic CSG selection in idle mode as well as Manual CSG selection. Autonomous search is performed to find CSG member cells, whereas the algorithms are left completely to UE implementation [24].

HeNBs as defined in Release 8 have multiple Access Control mechanisms:

- I. **Closed access Mode**(residential deployment): Access is only allowed for the subscribed user. The HeNB is defined as a Closed Subscriber Group cell and Access Control is located in the Gateway (GW).
- II. **Open access Mode**(enterprise deployment): All users are allowed access to the HeNB and receive the offered services.
- III. **Hybrid Access Mode** is an adaptive access policy between CSG and OSG. In this scenario, a portion of FBS resources are reserved for exclusive use of the CSG and the remaining resources are allocated in an open manner.

2.7.5 The Femtocells Evolved Packet System Architecture

The introduction of NoFs has some implications at the architectural level. However, the Broadband evolved FEMTO networks BeFEMTO architecture has been designed so that both User Equipment's (UE) and the core network are not modified. This section presents an overview of such implications by introducing the functional entities that need to be included or modified in order to grasp the benefits of NoFs.

On the other hand, the BeFEMTO Transport Network Architecture describes the underlying communication networks that transport the data between functional entities in the BeFEMTO EPS

Architecture. This comprises the local area network connecting a NoF and the fixed broadband backhaul. In this case, no modifications are required in the operator domain entities. However, those on the customer side are extended with additional routing and mobility management functionalities.

Figure 2.9 presents the entities of the BeFEMTO EPS architecture that are relevant in the NoF scenario. As shown, there are no modifications to the core network of the MNO except for the HeNB Management System (HeMS) and the Packet Data Network Gateway (P-GW). At a high level, the HeMS is in charge of providing all relevant configuration information to the HeNB in order to become operational. In BeFEMTO, the HeMS needs enhancements for supporting the new LFGW element (e.g., providing local management policies and cryptographic items to build the IPsec tunnels). The PGW is the entity that enables traffic exchange between mobile terminals and external packet data networks, such as the Internet. Among other tasks, the P-GW is in charge of IP address allocation to the UE, as well as traffic filtering for QoS provisioning. In BeFEMTO, the P-GW is enhanced for handling the S-rat (Remote Access Tunnel) interface, which is conceived for offering Local and Remote IP access consistently in terms of session and mobility management [10].

At the control plane level, the main functional entity is the Mobility Management Entity (MME), which is in charge of handling mobility related signaling (e.g., cell reselections, handovers, location updates, and paging). The MME is also in charge of authentication and security procedures between the UE and the core network. As for the data plane, the Serving Gateway (S-GW) is the functional entity in charge of forwarding UE data plane traffic to/from the P-GW through the S5 interface, as well as to/from the HeNB through the S1 interface. It is also the mobility anchor for intra-3GPP mobility. In the BeFEMTO vision, one of the main goals of a NoF is to confine data and control plane traffic to the NoF, hence offloading the core network and enabling more scalable femtocell deployments. This is

achieved by introducing a local Mobility Management Entity (referred to as Proxy MME, or P-MME) and a local Serving Gateway (referred to as Proxy S-GW, or P-SGW) the Local Femto Gateway (LFGW). This creates the need for additional network interfaces located between HeNBs and LFGWs. In terms of signaling, HeNBs in the NoF communicate with P-MMEs via the standard S1-MME interface. Similarly, communication on the user plane between HeNBs and P-SGWs is provided over the standard S1-U interface. In terms of data and control plane traffic on the mobile network layer, the presence of the LFGW is essentially transparent to the core network and the HeNBs. In fact, HeNBs behave in the same way as if the LFGW was not present. This applies for standard 3GPP procedures, i.e., those not involving the extended functionality enabled by the S-rat interface, as explained below. As a result of this, the LFGW appears to the functional entities in the core network as a standard HeNB. Thus, all existing 3GPP interfaces originated to/from a HeNB (S1-U, S1-MME, and X2) remain intact between the LFGW and the network elements in the core network. On the other hand, two new network interfaces (S-rat, Type 1C') have been introduced, as shown in Figure 2.10. The S-rat interface has been introduced between the LFGW and the P-GW to allow IP packet tunneling to/from the P-GW whenever data needs to be sent from/to the local network while the UE is currently in the macro network (e.g., during macro-to-Femto or Femto-to-macro handovers). On the other hand, the optional Type 1C' interface between the HeMS and the LFGW is used to provide configuration, software updates, network monitoring and management functionalities for the LFGW and the NoF as a whole.

On the other hand, the entities colored in orange have been enhanced or introduced by the Be FEMTO Evolved Packet System architecture. Given their importance in the realization of an efficient NoF.

2.7.6 Handoff Management

All mobile systems including the femtocell network implement a handover procedure to support the user's mobility. The handover, in one side allows communication during user's movement in the network. On the other side, it significantly increases signalling overhead in the network [23], it most likely that the soft handover will not be implemented in femtocell due to limited frequency allocation for femtocells. In addition, due to technological challenges and system operator requirements, the initial 3GPP specification for handover in femtocell focused on one direction only that is from Femtocell to macrocell eNodeB. Despite having some constraints, here we will mention the all possible handover scenarios between eNodeB and HeNB and between HeNBs. There are three possible handover scenarios in femtocell, as depicted

- I. Hand-in; this scenario presents the handover where an UE switch out from macrocell eNodeB to FAP.
- II. Hand-out; represents the handover that is performed from FAP to macrocell eNodeB.
- III. Inter-FAP handover; it corresponds to the scenario of handover from one FAP to another FAP. In this scenario all FAPs are assumed to be placed at the same location and served by the same service provider.

The P-MME is a functional entity that acts as an aggregation point for mobility-related messages in a NoF. It also acts as a local mobility anchor

in a hierarchical mobility management approach in order to minimize the signalling between the NoF and the EPC. Conceptually, the functional entities in the EPC handle all radio access network-related signalling (registration, bearer setup, idle and active mode mobility, etc.) as usual, while the P-MME hides mobility complexity between HeNBs from the EPC. The message sequence chart of an inter-HeNB handover is. In addition to the control- and user-plane messages, the tunnels needed for data transmission are shown (blue for the in-transit data and grey for forwarded data). In the Inter-HeNB handover, both the source and the target HeNBs belong to the same NoF and are attached (via the LFGW) to the same MME and S-GW in the EPC. Due to the presence of the LFGW, signaling procedures terminating in the core network are now terminated in the NoF, This essentially means that, from the point of view of the core network, UEs in the NoF are always connected to the LFGW and, therefore, remain camped on the same eNB.

2.7.7 Deployment Scenarios for Femtocells

Two types of scenarios: with pre-existing HeNB infrastructure and without it. In both types, following subcases must be considered:

- I. Deployment for controlled coverage: according to feedback of customers and measurements of the RAN, the operator defines areas where the coverage should be improved. The HeNB are installed in these limited areas.
- II. Free deployment for coverage or offloading or “home” services: in addition to scenario 1, HeNB offer is made available for customers and marketing actions ensure the customers know it. Customers can decide to buy a HeNB for improving their coverage or for

increasing the throughput inside their home. Value of the incentives associated to the offer, if any, is low or moderate.

- III. Pushed deployment for offloading or “home” services: on top of scenario 2, HeNB cell offer is strongly pushed to customer. Aim is to have a good ratio of customers using the HeNB. The offer may be associated with good incentives.

a- Scenario1:

Figure 2.10 shows the agreed architecture in 3GPP for LTE HeNB for scenario1. For variant 1, HeNB-GW serves as a concentrator for the C-Plane and also terminates the user plane towards the HeNB and towards the Serving Gateway

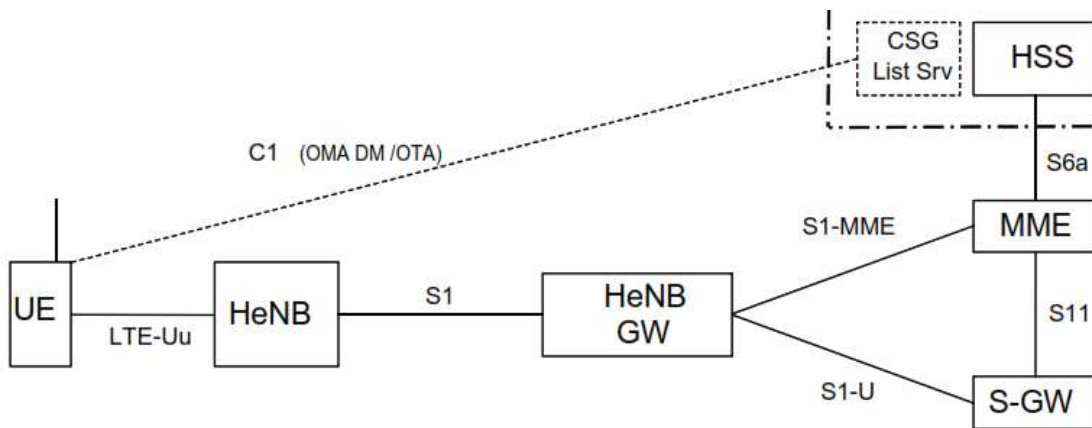

Figure 2. 100: Scenario 1 with dedicated HeNB-GW [16].

Here there is only one Stream Control Transmission Protocol SCTP association between HeNB-GW and MME. One SCTP association exists between each HeNB and HeNB-GW. By increasing the number of HeNBs in the network, SCTP association towards MME remains unaffected. This may be beneficial in terms of the following parameters:

- I. SCTP heartbeat messages are kept at minimum towards MME. SCTP heartbeat messages (per SCTP association) do not overload MME due to increasing the number of HeNBs in the network.
- II. Serving Gateway scalability requirements for GTP/UDP/IP connections respectively are reduced comparing to other variants. Number of UDP/IP Paths and the number of GTP Echo messages that S-GW needs to manage remains minimum. Increasing the number of HeNBs does not increase the number of UDP/IP Paths and GTP Echo messages to be managed by S-GW.
- III. HeNBs do not have to support S1-Flex that will both reduce the overall number of S1 connections and simplify HeNB implementation.
- IV. IP addresses of MME and S-GW can be hidden from HeNB in this variant. This would result a better controlled system.
- V. This variant allows Traffic offload (SIPTO) to be done at the HeNB-GW. Local S-GW and P-GW functionality for SIPTO may be implemented within the HeNB-GW reducing the need for a new network element.
- VI. Handover optimization and reduction of Handover related signalling load to MME/S-GW can be realized. User Plane Path switch message exchange between MME and S-GW will be reduced for handover between HeNB Access points (in case core network does not need to know about change of serving cell).

But still all the HeNBs connects to a single HeNB-GW at one time. It reduces redundancy and load sharing possibilities in comparison with variant 2.

b- Scenario2:

Figure 2.11 shows the agreed architecture in 3GPP for LTE HeNB for scenario 2, here the S1-U interface of HeNB is terminated in S-GW and S1-C interface in MME, as per eNB. The HeNB may have connection to multiple MME/S-GW, i.e. may support S1-flex.

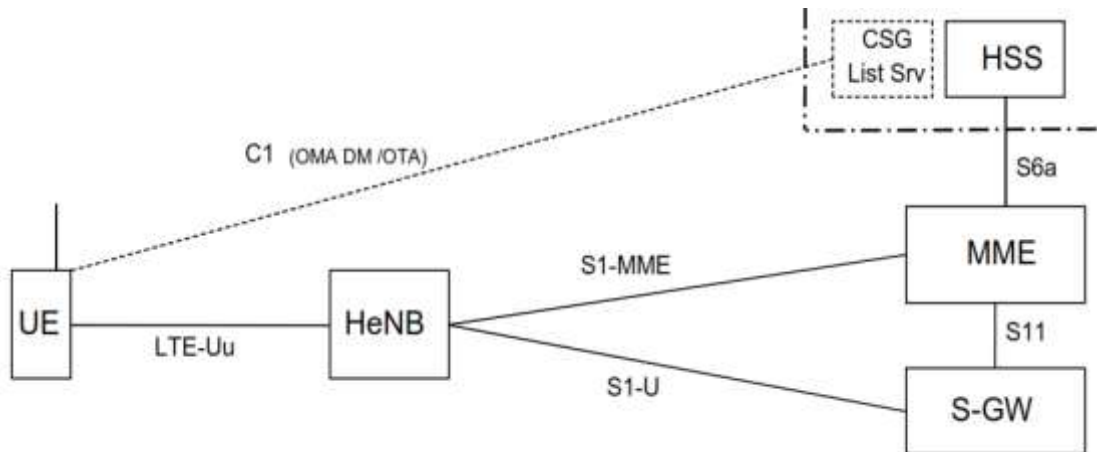

Figure 2.11: scenario 2 without HeNB-GW

This may be beneficial in terms of the following parameters:

- I. There are less failure points in the system and no additional single point of failure. If one HeNB network element fails below the MME/S-GW, the other HeNBs are not affected like in case of HeNB-GW failure.
- II. Simple flat architecture of this variant has less network elements to be operated and is consistent with macro architecture (e.g. S1 flex support on HeNB).
- III. Lower latency and reduced system level processing is achieved, because the S1 C-plane and U-plane are directly connected from the HeNBs to the MME and S-GW without protocol termination at the HeNB-GW.

But also it has few drawbacks like it does not provide SCTP/GTP-U connection concentration. So in this case of increasing number of HeNBs in the network, the SCTP heartbeat messages (per SCTP association) might cause an overload situation in MME.

In case of increasing number of HeNBs in the network, the period for GTP-echo messages might need to be increased to avoid an overload situation in S-GW.

c- Scenario 3:

Figure 2.12 shows the agreed architecture in 3GPP for LTE HeNB for scenario 3, HeNB-GW is deployed and serves as a concentrator for the C-Plane. The S1-U interface of HeNB is terminated in S-GW, as per eNB. This may be beneficial in terms of the following parameters:

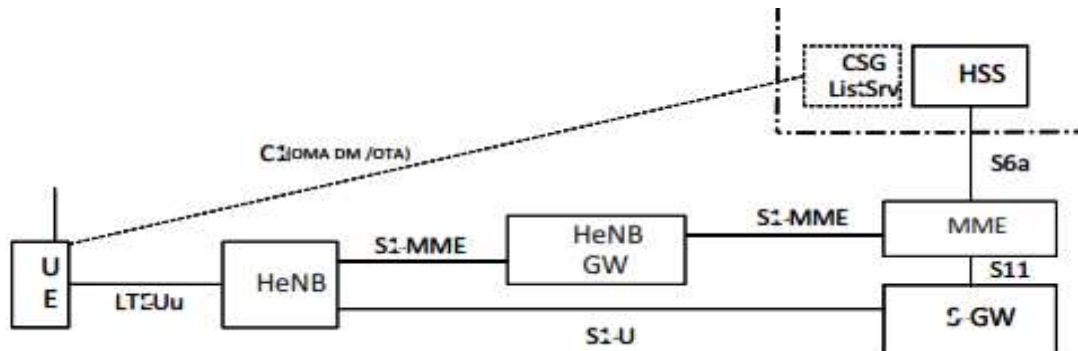

Figure 2.12: scenario 3 with dedicated HeNB-GW in C-Plane only

- I. There is only one SCTP association between HeNB-GW and MME. One SCTP association exists between each HeNB and HeNB-GW. By increasing the number of HeNBs in the network, SCTP association towards MME remains unaffected.
- II. HeNBs do not have to support S1-Flex on C-plane that will both reduce the overall number of S1 C-plane connections and simplify HeNB implementation.

- III. This variant allows the possibility to implement Paging optimization mechanism within HeNB-GW.
- IV. In U-Plane, there are less failure points in the system and no additional single point of failure.
- V. Lower latency and reduced system level processing is achieved in U-Plane, because the S1 U-plane is directly connected from the HeNBs to S-GW without protocol termination at the HeNB-GW.
- VI. Handover optimization & reduction of Handover related signalling load to MME/S-GW can be realized, when X2 is used for U-Plane between HeNB connected to the same HeNB-GW. In this case, User Plane Path switch message exchange between MME and S-GW will be reduced for handover between HeNB Access.

Although of these benefits it also in case of increasing number of HeNBs in the network, the period for GTP-echo messages might need to be increased to avoid an overload situation in S-GW.

Additional or dedicated S-GW might be required to solve the possible overload situation. In case dedicated S-GW are deployed, additional GW relocation load may occur for macro-HeNB and HeNB-macro handovers.

In C-Plane, HeNB connects to a single HeNB-GW at one time. It reduces redundancy and load sharing possibilities in comparison with variant 2.

Chapter Three
Methodology

3.1 Existing Algorithms (Conventional Algorithms)

Many algorithms have been proposed to solve the hotspot cell problem. They can be classified by resource allocation scheme and load distribution scheme. In research area of resource allocation scheme, major papers proposed channel borrowing algorithms which utilize remained resources of minimum loaded cells [29]. And, in research area of load distribution scheme, firstly, there are algorithms that control the transmitting power of the base station in order to distribute traffic load of the hotspot cell. ACS (Adaptive Cell Sizing) scheme is the representative algorithm which controls the transmitting power of the base station based on cellular system. Secondly, to distribute traffic load of the hotspot cell, handover-based algorithms which use functionalities of handover mechanism have been proposed.

Among many algorithms, soft handover area resizing is referred to as the representative algorithm. [31] exploits features of soft handover functionality of CDMA cellular system in order to reduce load of the hotspot cell. With the scheme, the hotspot cell increases the threshold value, T_{DROP} in order to reduce its soft handover area and if this threshold value is increased, the users who belong to the soft handover area are forcibly handed over the neighboring cells. The released resources in the hotspot cell are allocated to additional call requests with satisfying the total transmitting power constraints.[30]

Previous works only focus on distribution of traffic load of the hotspot cell without considering the load status of neighboring cells. If neighboring cells are also heavily loaded, they can be also hotspot due to the traffic load distributed from the hotspot cell. And, the works only consider the situation

that the status of hotspot is maintained for a quite long time. They may not effectively deal with the cell whose status becomes hotspot during at most a few minutes. In summary, if existing algorithms are applied to manage hotspot cells in 4G mobile networks, they may cause more hotspot cells in all the service area and may cause more deterioration of the service quality. Therefore, an effective hotspot cell management scheme suitable for 4G mobile networks is needed.

3.2 The Proposed Algorithm

In this thesis, a new handover adaptive time-based scheme proposed, which can effectively manage hotspot cells in 4G Femtocells. 4G cellular systems will use OFDM as the physical layer technology and support hard handoff. Therefore, the proposed scheme which adopts hard handoff mechanism dynamically changes the time point of handover according to the load status of cells. The scheme can prevent the outbreak of hotspot cells within the network and enhance service quality. In the simulation results, we should find that the proposed scheme supports higher satisfaction level of users than the conventional scheme.

3.2.1 Adaptive Handover Time Scheme

A new adaptive time handover scheme presented for effective hotspot cell management in 4G mobile networks. Adaptive handover time means the time point of handover is dynamically changed according to the amount of traffic load of cells. The proposed scheme is based on hard handoff mechanism for cellular systems based on OFDM and MAHO(Mobile-Assisted Handoff) method. The scheme assumes that cells are connected through backbone network without restraints of the structure.

The scheme is also expected not to impose high system complexity because the scheme only adopts hard handover parameters, hysteresis and absolute thresholds, without changing the mechanism itself. Conventional handover mechanism is based on degradation of the pilot signal strength of the base station. It does not consider the amount of load of the current serving cell and the target cell. If a handover is executed with using both signal strength and load information, base stations can recommend the best serving cell for users with guaranteeing high service quality. [32]

Figure 3.1 shows the process of adaptive handover time scheme. As shown when the current serving cell, **HeNB1** receives the report from a mobile which includes signal strength and the signal strength is weaker than the specific threshold, **HeNB1** requests the load information of the target cell, **HeNB2**. If **HeNB1** determines that **HeNB2** will become the status of hotspot due to increased load caused by handover calls, **HeNB1** sends the hotspot alarm message, **HOTSPOT ALARM** to **HeNB2**. And **HeNB1** delays all handovers caused by users who belong to the handover area between **HeNB1** and **HeNB2**. It recognizes that its status will be hotspot due to additional load caused by handover calls and reduces its load by executing all possible handovers earlier than scheduled in conventional handover mechanism. Through the fast handover execution, **HeNB2** can obtain available resources and prepare to handover calls occurred in the near future. If **HeNB2** gets out of the status of hotspot with fast handover execution and obtains the sufficient amount of available resources, **HeNB2** sends the hotspot release message, **HOTSPOT RELEASE** to **HeNB1**. [32]

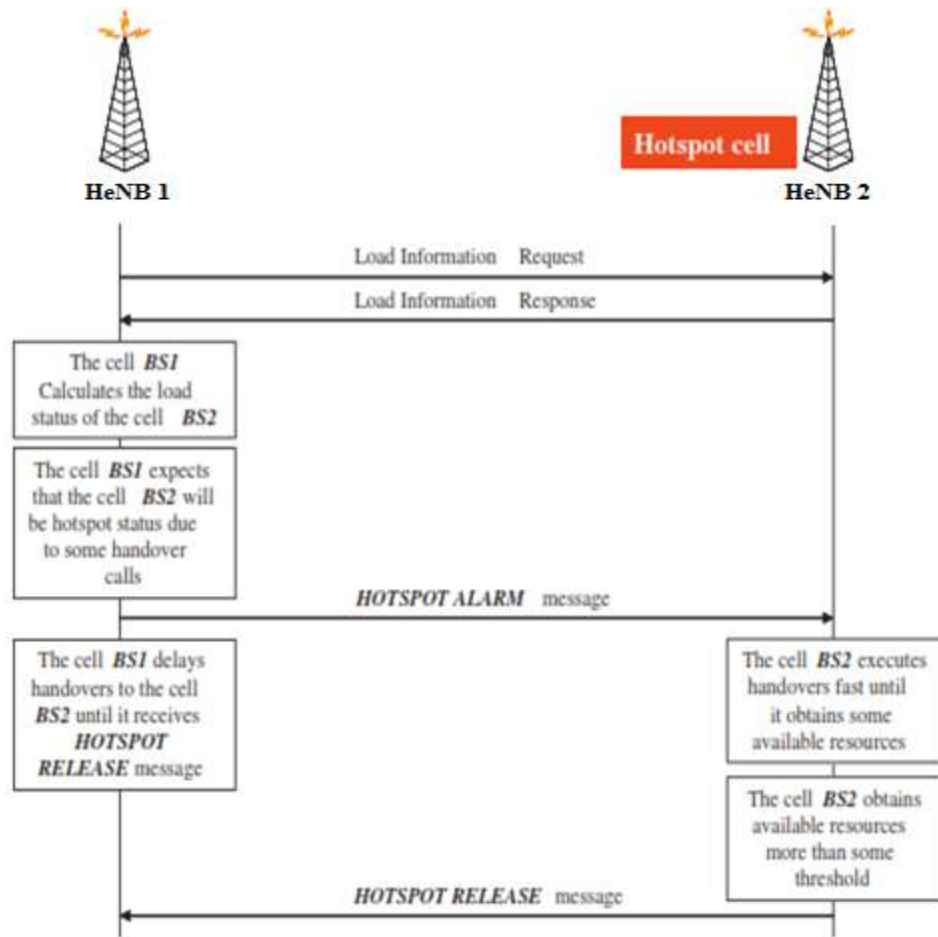

Figure 3. 1: Process of adaptive handover time scheme.

3.2.2 The Algorithm Flow chart

Figure.3.2 shows the Adaptive time algorithm used to enhance the conventional algorithm, when the RSS of the serving cell is less than threshold value this means handover is required and should be executed, however in this scheme it would never be executed before it sends the load information request message to the target cell and receive load information response message from the cell in order to take the proper decision. The target cell calculates the amount of traffic load. If the amount of available resources of the target cell is less than the hotspot cell threshold, the current

serving cell sends hotspot alarm message to the target cell and it will schedule the handoff requests until the hotspot cell returns with a feedback saying that it has available resources to provide by sending hotspot release message to serving station. Now, handover is executed to target station (TS) [32].

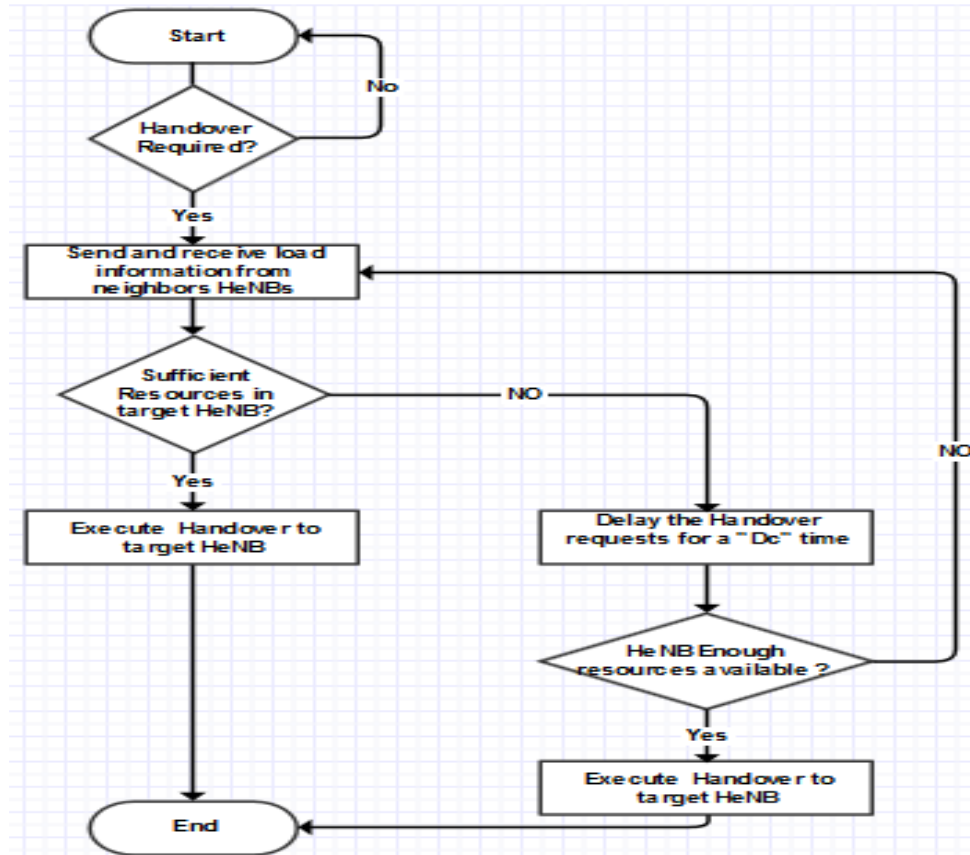

Figure 3. 2: Flow chart of adaptive handover time scheme.

3.3 Modelling of the Network

The network model is consists of two models, the Physical Model and the Mathematical Model which together forms the whole concept of the proposed algorithm. Below both of the models discussed in details.

3.3.1 Physical Model

In this section, the load consideration in the scheme is discussed in term of physical scenario. If the amount of load which will be increased due to handover calls is considered in advance before handover execution, cells can effectively manage their load by flexibly controlling handover time. Performance of the scheme may be significantly affected by the correctness of load information of the target cell. Typically, traffic load in a cell can be estimated by the amount of occupied resources. However, the estimation may not be

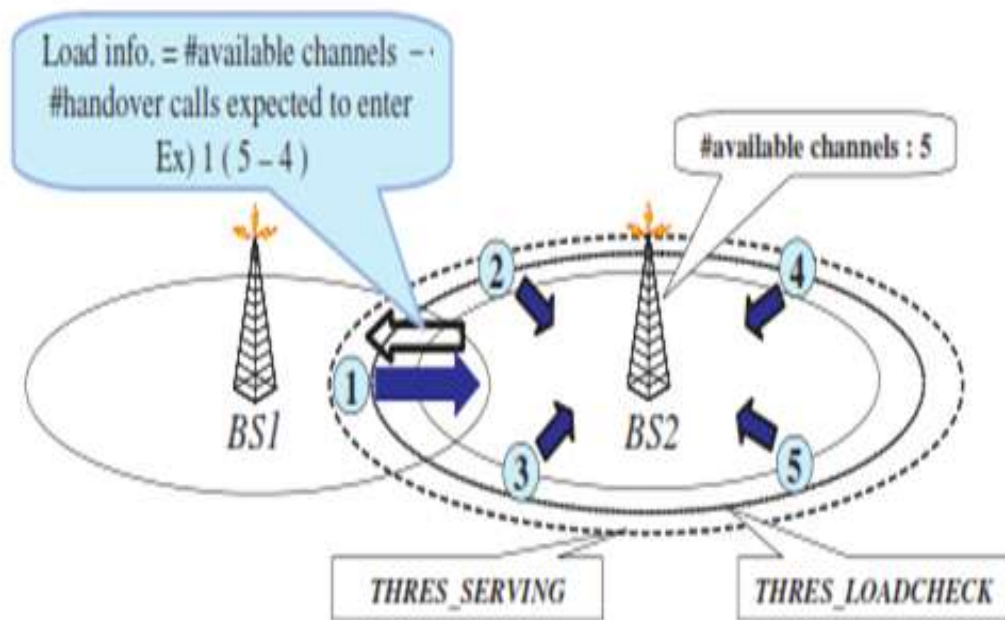

Figure 3. 3: Physical load calculation process.

exact because it does not include the amount of load expected to be added in the cell. Therefore, the proposed scheme considers both the amount of occupied resources and the number of handover calls as the amount of load expected to be added.

The figure represents how the load is calculated in advance of handover execution, which is calculated considering the neighbors load and subtracted from the overall cell node, this gives the cell QoS a huge boost in performance.

3.3.2 Mathematical Model of Performance Metrics

i. Resource Utilization

Resource is the time and frequency that shared among users, because of the heavily loaded cell there is lack in resources in hotspot cells, where there is resources in the coldspot remains unused which mean inefficient resource utilization shown in equation (3.1), in the adaptive handover time scheme the resource in coldspot is borrowed to the hotspot cell so then the utilization of resources is improved, shown in equation (3.3).

- Conventional scheme

$$R_u = \frac{R_{AH}}{R_t} \quad (3.1)$$

- Adaptive handover time scheme

$$R_{th} = R_{AH} + (R_{tc} - R_{hc}) \quad (3.2)$$

$$R_u = \frac{R_{th}}{R_t} \quad (3.3)$$

Where:

R_u : Utilized Resource

R_{th} : Total resource in hotspot

R_{AH} : Available resources in hotspot

R_{tc} : Total resource in coldspot

R_{hc} : hold resource in cold spot

R_t : Total resource in the system.

ii. Blocking Probability

Blocking probability is the fraction of how many users are blocked due to lack of resources available; inefficiency utilize of resources in conventional scheme will raise the blocking probability, equation (3.4) shows how the blocking probability is calculated on the conventional scheme. The adaptive handover time scheme raises the amount of the resources, which lead to decrease the blocking probability; equation (3.5) shows how Blocking probability measured in the new scheme.

$$R_t = N + BN_{HOLD} + N_{HO} \quad (3.4)$$

Where:

R_t : Total resource in system.

N : number of user on state.

B : adaptive factor (0-1).

N_{Hold} : Number of user in hold state.

N_{HO} : Number of handoff calls.

- **Conventional scheme**

$$P_r = \frac{R_t - R_h}{R_t} \quad (3.5)$$

Where:

R_t : Total resource in system. R_h : Total resource in hotspot.

- **Adaptive handover time**

$$P_r = \frac{(R_t - R_{th})}{R_t} \quad (3.6)$$

$$R_{th} = R_h + R_c \quad (3.7)$$

Where:

R_h : Total resource in hotspot

R_{th} : Available resources in hotspot and coldspot cell.

R_c : Available resource in the coldspot cell

iii. Scheduling Delay Time

It is the time interval in which the scheme should use to delay the handover, the delay time in conventional scheme will be smaller and fixed, however the delay time in the time adaptive scheme is different as it is required when there is a congestion or there is a hotspot cell case. The conventional scheme calculation is shown in equation (3.8), and the adaptive handover time scheme is shown in equation (3.9).

- **Conventional scheme**

$$D_T = D_c + D_t \times N \quad (3.8)$$

Where:

D_T : Total time in current cell

D_t : Handover delay in cell

D_c : delay time in cell

N : Number of cells

$$D_c = \frac{H}{C - R} \quad (3.9)$$

Where:

H : Average hold time.

C : Channel capacity.

R : Resources.

- **Adaptive handover time**

Adaptively changed, which could be randomly distributed.

iv. Data Rate

It is the rate in which data could be transmitted from one device to another. In other words, it is the amount of data which transmitted in one second. When using the conventional scheme the bandwidth will

decrease due to the inefficient use of resources, which shown in equation (3.4.a) .

On the other hand, Adaptive handover time scheme increase the amount of resources in a hotspot cell by borrowing it from neighboring cells, which increases the bandwidth so that the data rate will peak for every user, this presented in equation (3.10)

- **Conventional scheme**

$$D_R = B \times M \times C \quad (3.10)$$

D_R : Data Rate

B : Bandwidth

M : Modulation Factor

C : Coding Rate

- **Adaptive handover time**

$B = B + \text{Available Bandwidth on the other cells}$

v. Packet Delay

It is the time taken for a packet to be transmitted across a network from source to destination. Packet delay has inverse proportional to resources, in conventional scheme shown in equation (3.11). In adaptive handover time, the delay is directly proportional to the resource illustrated in figure (3.12).

- **Conventional scheme**

$$T = n \frac{(H + L(P))}{C} \quad (3.11)$$

- **Adaptive handover time**

$$T = n \frac{(H + L(P))}{C} \quad (3.12)$$

Where:

L: total size of application data.

P: packet number.

n: number of bits in packet.

C: capacity of the link (bit/second).

H= header size (bit).

3.4 Simulation model and scenario

The simulation scenario contains three LTE femtocells with three different frequencies, a coverage of 10 meters, bandwidth of 20 MHz, a maximum number of users within the cell configured to be 20 user, the default delay is 0.02 ms. In addition to these parameters there are many calculated within the code using the algorithm equations.

The table below presents the main simulation parameters used on this thesis in order to simulate and compare the two schemes.

Parameter	Assumed Value
Bandwidth	20 MHZ
Number of Femtocells	3
Femtocells coverage	10 meters
Number of users per cell	20
Number of channels per cell	100
Delay	0.02
Frequencies for HeNB1, HeNB2 and HeNB3	2300MHZ,2310 MHZ, 2320 MHZ

Table 3.1: Simulation Parameters

3.4.1 Simulation Tool

MATLAB (Matrix laboratory) is an interactive software system for numerical computations and graphics. As the name suggests, MATLAB is especially designed for matrix computations: solving systems of linear equations, computing values and eigenvectors, factoring matrices, and so forth. In addition, it has a variety of graphical capabilities, and can be extended through programs written in its own programming language. Many such programs come with the system; a number of these extend MATLAB's capabilities to nonlinear problems, such as the solution of initial value problems for ordinary differential equations. It is a very powerful program for technical and scientific numerical programming. It is so popular (and expensive) that several MATLAB clones are available nowadays. Both commercially as well as freeware. Search on the Internet

for 'MATLAB' and 'clone' and you will find 'Octave', 'O-matrix' and several others. Unfortunately, none of these free tools are up to the MATLAB standard of quality yet.

The best way to explore MATLAB is by using it. The command demo brings up a GUI from which you can choose various basic tutorials and demonstration programs.

The help files are quite extensive. There is a plain ASCII text help system as well as a HTML based help system (the 'help desk'). You are advised to read the 'getting started' tutorial that is available on all MATLAB installations.

Chapter Four
Samlation Results and Analysis

Introduction

After finishing the mathematical model, and using MATLAB to simulate the development on performance metrics by taking average value of ten samples from ten seconds to calculate the improvement happened in the resource utilization, blocking probability, delay time, throughput and quality of services (data rate, packet delay and jitter), are then represented on graphs to be clearly demonstrated and presented.

4.1 Resource Utilization

The percentage of resource utilization in adaptive handover time scheme compared to the conventional scheme shown in Figure (4.1), where blue line indicates the adaptive handover time and the red dashed line illustrates the conventional scheme, it can be clearly seen that the resource utilized on the enhanced scheme overcomes that of conventional scheme, in which it rises by an average of 40 %, this is due to the borrowing mechanism on the hotspot femtocells.

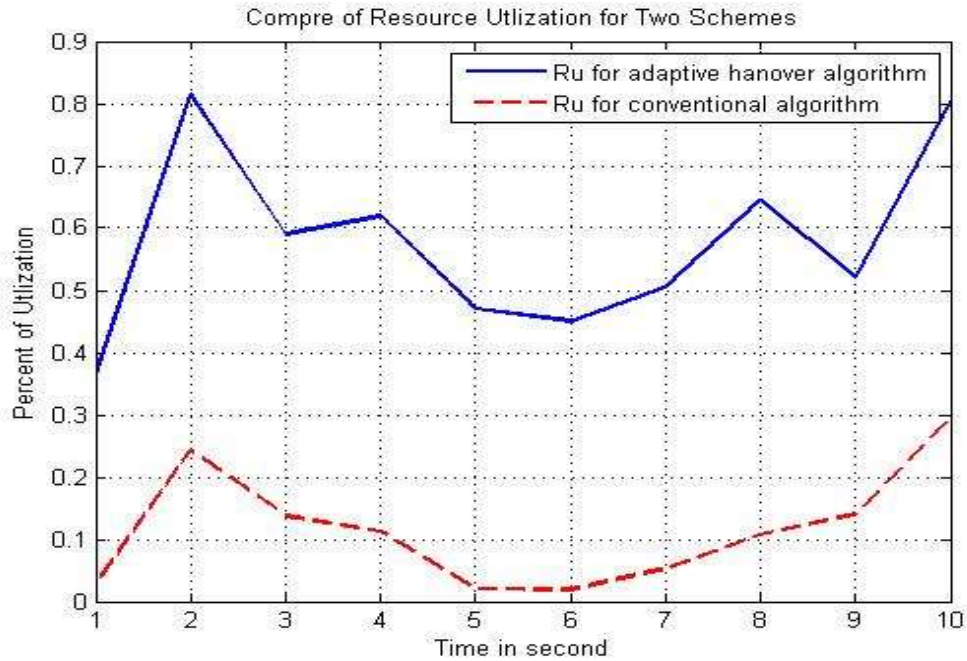

Figure 4. 1: Compare of Resource Utilization for Two Schemes

4.2 Blocking Probability

The resource utilization percentage when adaptive handover time scheme used is higher than conventional scheme which leads to decrease the blocking probability dramatically, it's shown in Figure (4.2), where the red line represent the conventional scheme and the blue dashed line represent the adaptive handover time scheme. It can be clearly seen that the blocking probability when the conventional scheme applied is more than the contrary the figure for the enhanced scheme are really impressing as it is only reached less than 70% of blocking probability on the conventional scheme.

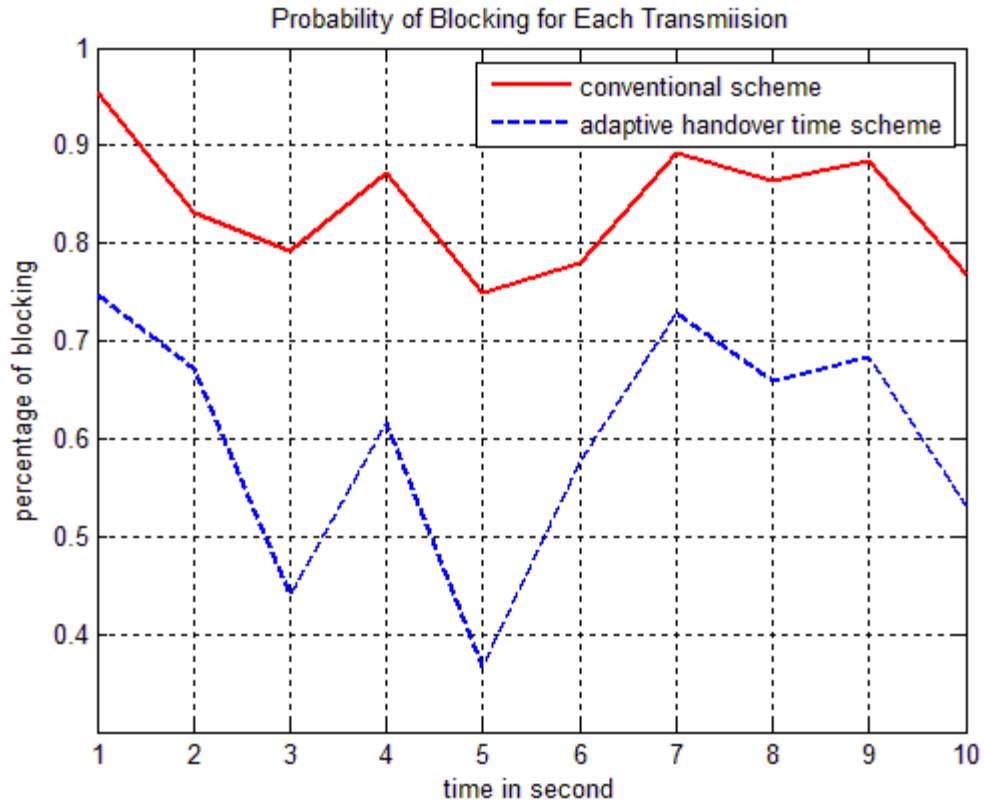

Figure 4. 2: Compare Blocking Probability in Adaptive Handover Time Scheme and

4.3 Data Rate

Figure 4.3 illustrates the data rate, in which blue dashed line determine the adaptive handover time scheme and the red line determine the conventional scheme, the data rate on the new scheme is higher than that of conventional scheme. The results also showed that the new scheme is better in term of data rates per transmission.

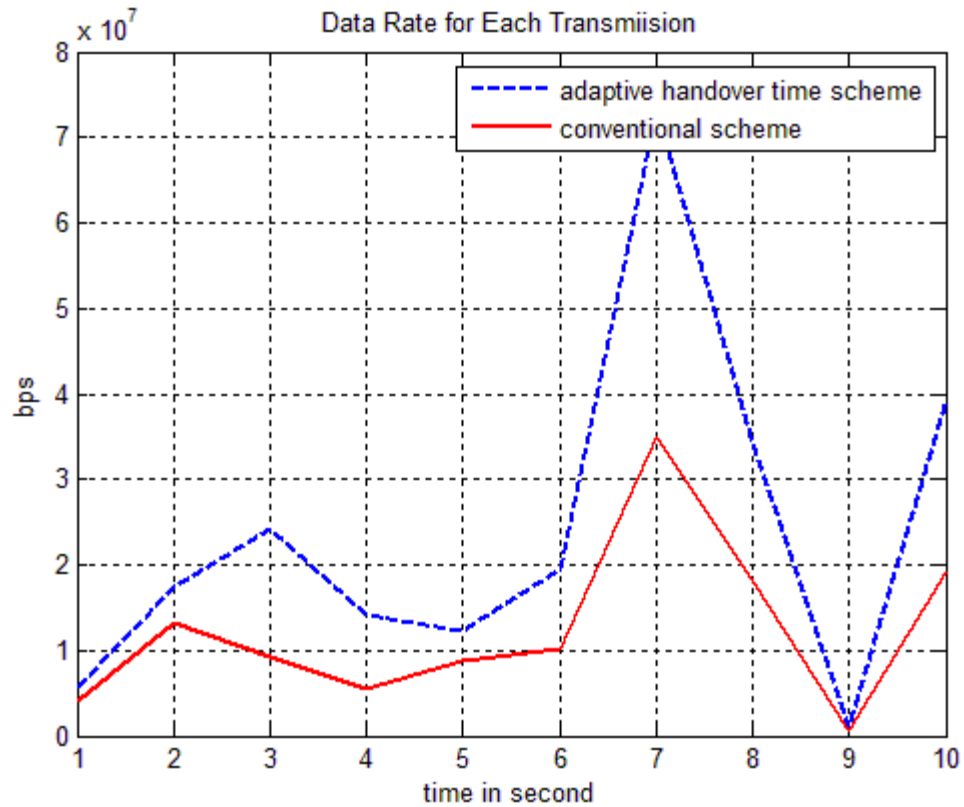

Figure 4. 3: Compare Data Rate between Adaptive Handover Time and Conventional Scheme

4.4 Transmission Delay Time

The delay time when using adaptive handover time scheme is less than conventional scheme by slight percentage seen in a Figure (4.4), where the red line represent the conventional scheme and the dashed blue line represent the adaptive handover time scheme.

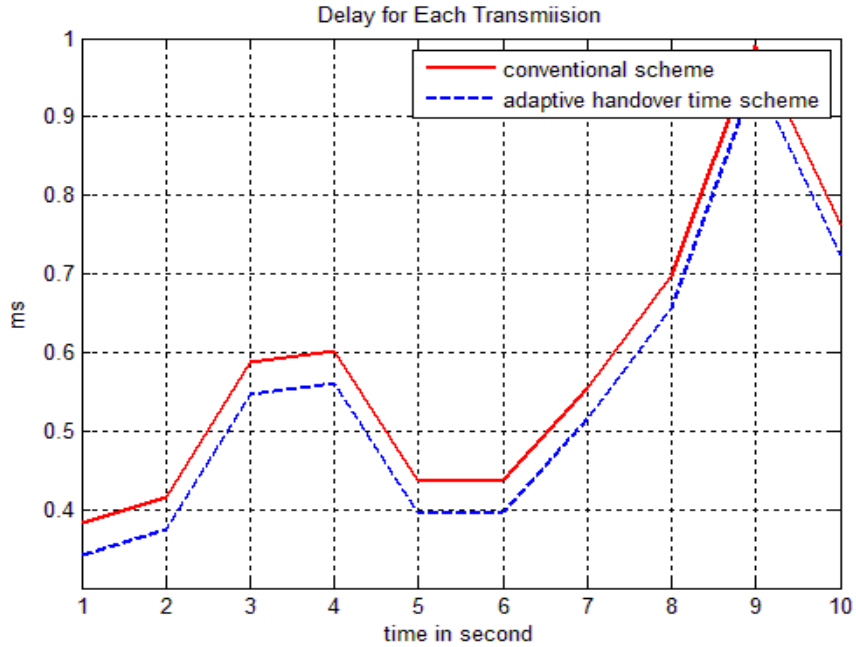

Figure 4. 4: Delay Time in Adaptive Handover Time Scheme and in Conventional Scheme

4.5 Packet Delay

The adaptive handover time scheme enhancing the quality of service by reducing the packet delay by below to 10% less than conventional scheme shown in Figure (4.5), where the red line indicate the behavior of the conventional scheme during the interval and the blue dashed line represent the adaptive handover time scheme, this decreasing is due to resource borrowing from coldspot cells and hence increasing the resources sufficiently in the hotspot cell lead to serve all users with minimum delay.

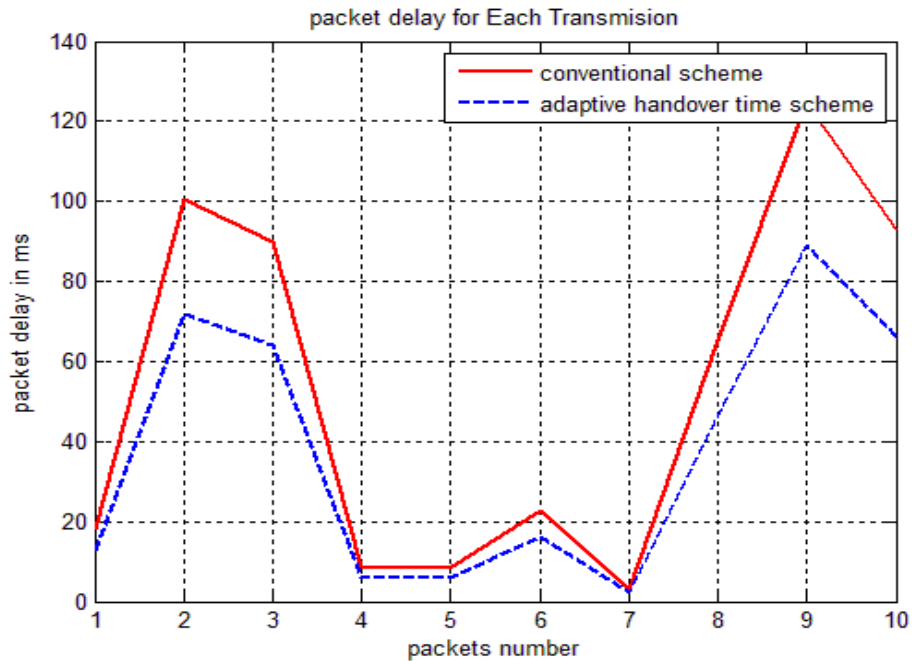

Figure 4. 5: Comparing Packet Delay between Adaptive Handover Time Scheme

4.6 Throughput

Corresponding to the increasing in the data rate by Adaptive handover time scheme this leads to increase the throughput compared to the conventional scheme, Figure (4.6) represents the throughput comparison between the two schemes.

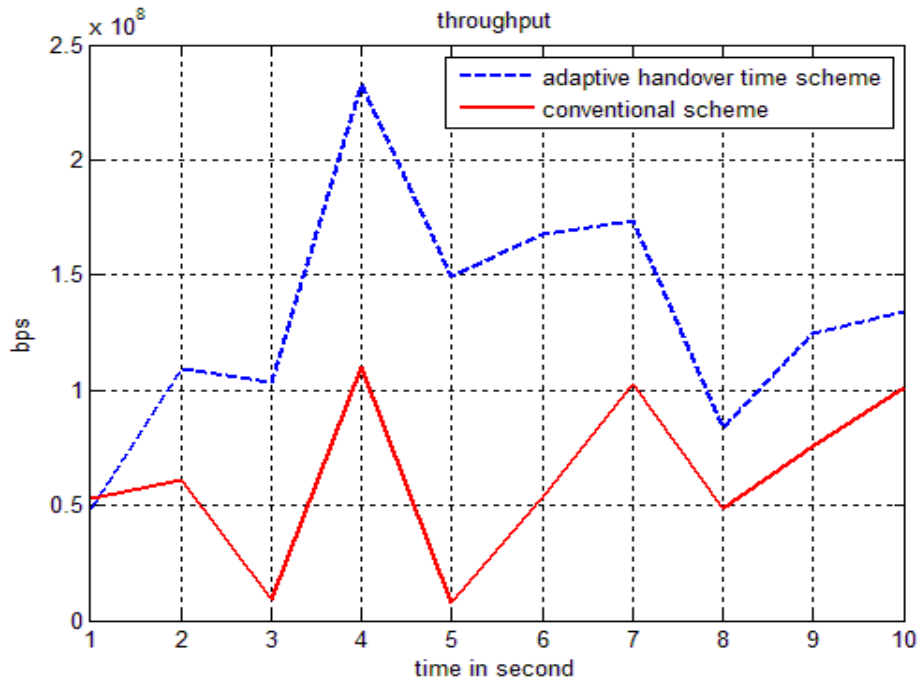

Figure 4. 6: Throughput for Adaptive Handover Time Scheme and Conventional Scheme

Chapter Five
Conclusion & Recommendation

Conclusion

This thesis investigated the use of the adaptive handover time scheme to enhance the handover performance in LTE femtocell systems. This presented by a mathematical model and simulation using MATLAB.

The results focused on the main performance metrics that reflects the performance of the handover scheme used and therefore reflects the quality of service offered by the cells. The results showed that in all QoS measures the adaptive handover time scheme overcomes the conventional scheme , this is by decreasing the delay, blocking probability on one hand, and on the other hand increased the utilization of resources and bandwidth, throughput and data rate.

The comparison with the traditional algorithm shows that the algorithms proposed in this research have a better performance in the most performance indicators and it increase the utilization of the system although in the case of lake resources.

Future Work and Recommendations

As a recommendation for future work, applying the algorithm for Microcell to Femtocell handover is highly recommended to investigate the performance of the scheme in a larger scenario. And significant increase in user's speed might reduce its stay in the femtocells to a few seconds and trigger a series of continuous handovers between different femtocells with increasing overhead and severe degradation of TCP good put. Thus, our future interest lies in reducing such unnecessary handovers to improve the performance even further.

References

[1] Chandrasekhar, V., Andrews, J.G., Gatherer, A. *Femtocell networks: a survey*, IEEE Communications Magazine, 46(9), pp. 59-67, (2008)

[2] S. Prasad and R. Baruah, “Femtocell Mass Deployment: Indian Perspective,” in Anticounterfeiting, Security, and Identification in Communication(ASID),3rdInternational Conference on, August 2009, pp. 34 – 37.

[3] Mahmoud Outqut and HossamHassanein, Mobility Management in Wireless Broadband Femtocells, , Technical Report 2012-590, School of Computing, Queen’s University Kingston, Ontario, Canada 2012.

[4] J. Sun and J.Sauvola,“Mobility and Mobility Management:A Conceptual Framework,”in Networks (ICON).10th IEEE International Conference on, 2002, pp. 205 – 210.

[5]<http://www.radio-electronics.com/info/cellulartelecomms/femtocells/femto-cells-network-architecture.php>

[6] F. Zdarsky, A. Maeder, S. Al-Sabea, S. Schmid, Localization of Data and Control Plane Traffic in Enterprise Femtocell Networks, in Proceedings of IEEE 73 rd Vehicular Technology Conference (VTC Spring 2011), 15-18 May, 2011, Budapest (Hungary).

[7] Pierre Lescuyer and Thierry Lucidarme, Evolved Packet System (EPS) The LTE and SAE Evolution of 3G UMTS Both of Alcatel-Lucent, France

[8] Stefania Sesia, IssamToufik and Matthew Baker, The UMTS Long Term Evolution: From Theory to Practice © 2009 John Wiley & Sons, Ltd. ISBN: 978-0-470-69716-0

- [9] Ali-Yahiyam, Understanding LTE and its Performance T. 2011 XXV, 250 p., Hardcover ISBN: 978-1-4419-6456-4
- [10] Spain & NEC Europe Ltd, Traffic and Mobility Management in Networks of Femtocells CTTC, Centre Tecnològic de Telecomunicacions de Catalunya Barcelona – Heidelberg – Germany 2014.
- [11] Ren-Huang Liou, Yi-Bing Lin, Fellow, IEEE, and Shang-Chih Tsai Department of Computer Science National Chiao Tung University, An Investigation on LTE Mobility Management y 2012 rhliou, liny, tsaisc}@cs.nctu.edu.tw.
- [12] AbouckOpu Narcisse, Prof. TimoHämäläinen, an Investigation on Mopility Management in LET-A Inter-HENB Network Of Femtocells.2013
- [13] Tianyu Xiang, Joan Serrat, Juan Luis Gorricho, Efficient Mobility Management in LTE Femtocell Network, Barcelona, August 2014.
- [14] ZdenekBecvar, Pavel Mach Czech Technical University in Prague Adaptive Hysteresis Margin for Handover in Femtocell Networks, Faculty of Electrical Engineering, Department of Telecommunication Engineering Prague 16627, Czech Republic.
- [15] Jen Chen, Peter Rauber, Damanjit Singh, ChandruSundarraman, PeerapolTinnakornsriruphap, Mehmet Yavuz, Femtocells – Architecture & Network Aspects ,.
- [16] HeNB (LTE Femto) Network Architecture Published by the Femto Forum May 2011.
- [17] Zdenek Becvar, Pavel Mach Czech, Adaptive Techniques for Elimination of Redundant Handovers in Femtocells, Technical University

in Prague, Faculty of Electrical Engineering, Department of Telecommunications Engineering Prague 16627, Czech Republic.

[18] Handover Problem For Integating LET With Femtocell Network ,A.Bagupali, V.prithiviraj,p.s. Mallick,Kishore V Krishnan Asst Prof., School of Electronics Engineering, VIT University, Vellore Prof., Department of Electronics and Communication Engineering, PEC, Puducherry Prof. , School of Electrical Engineering, VIT University, Vellore Asst Prof.,.

[19] Haijun Zhang, XiangmingWen, Bo Wang, Wei Zheng and Yong Sun, School of Information and Communication Engineering, A Novel Handover Mechanism between Femtocell and Macrocell for LTE based Networks, , Beijing University of Posts and Telecommunications 2011, Beijing, China.

[20] Usama Mian, Ahmad Mudassir, SaleemAkthar COMSATS Institute of Information Technology, A survey on Handover Issues and Management Techniques for LTE Heterogeneous networks, , Lahore, Pakistan 2016.

[21] Ketyllen da Costa Silva , Carlos P. Alves da Silva, André Cunha de S. Donza , Carlos Renato L. Frances, Nandamudi L. Vijaykumar, Analysis of Handover Based on The Use of Femtocells in LTE Networks, 2014.

[22] Faisal A. Al-Shahin, State Audit Bureau, Femtocell-to-Femtocell Handoff Management in Dense Femtocellular Networks, , Kuwait. Manuscript submitted July 9, 2014; accepted April 11, 2015. doi: 10.17706/ijcce.2015.4.5.346-353.

[23] ArdianUlvan, Robert Bestak , Department of Telecommunication Engineering Czech Technical University in Prague, Czech Republic

&MelviUlvan, Department of Electrical Engineering, Handover Scenario and Procedure in LTE-based Femtocell Networks, , The University of Lampung Bandar Lampung, Indonesia.

[24] Eiko Seidel, ElieSaad, LTE Home Node Bs and its enhancements in Release 9, Mai 2010, , Nomor Research GmbH, Munich, Germany.

[25] Multi-Objective Handover in LTE Macro/Femto-Cell Networks, Article in Journal of Communications and Networks October 2012.

[26] AzitaLailyYusof, Mahamod Ismail, and Norbahiah Misran Department of Electrical, Traffic Management Algorithm and Adaptive Handover Summary Initiation Time for Dynamic Traffic Load Distribution, , Electronic and System Engineering, UniversitiKebangsaan Malaysia,43600 UKM Bangi Selangor, Malaysia 2010.

[27] Budiarto Herman, Dmitry Petrov, Jani Puttonen, JanneKurjenniemi Magister Solutions Ltd, A3-Based Measurements and Handover Model for NS-3 LTE,. Jyvaskyla, Finland.

[28] Dongwook Kim, Seunghak Lee, Hanjin Lee, and HyunsooYoon Dept, An Effective Hotspot Cell Management Scheme Using Adaptive Handover Time in 4G Mobile Networks,. of EECS, Korea Advanced Institute of Science and Technology, Daejeon, Republic of Korea.

[29] S. Das, S. Sen and R. Jayaram, “A dynamic Load Balancing Strategy for Channel Assignment Using Selective Borrowing in Cellular Mobile Environment”, Proceedings of IEEE/ACM Conference on Mobile Computing and Networking (Mobicom96), pp. 73 - 84, Nov. 1996

- [30] S. Das, S. Sen P. Agrawal and R. Jayaram, "A Distributed Load Balancing Algorithm for the Hot Cell Problem in Cellular Mobile Networks", Proceedings of 6th IEEE International Symposium on High Performance Distributed Computing, pp. 254 - 263, 1997.
- [31]. H. Jeon, S. Hwang and S. Kwon, "A channel Assignment Scheme for Reducing Call Blocking Rate in a DS-CDMA Cellular System", Proceedings of 6th IEEE International Conference on Personal Communication, Vol. 2, pp. 637 - 641, 1997.
- [32] Dongwookkim, seunghaklee, hanjin lee and hyunsooyoon, —an effective hotspot cell management scheme using adaptive handover time in 4G mobile networks|| , IEEE, 2005, 5 pages.

Appendices

Appendices

MATLAB Source Code

```
clc,clear,close all,
%Number of Total Duplex Chaneel
Total_channel=30;
%% CARRIER FREQUENCY
First_HeNB_Frequency=2300*10^6;%% HeNB= a Home eNB is an LTE
4G femtocell.
Second_HeNB_Frequency=2310*10^6;%% HeNB= a Home eNB is an
LTE 4G femtocell.
Third_HeNB_Frequency=2320*10^6;%% HeNB= a Home eNB is an LTE
4G femtocell.

i=1;          % Sample for 50 Seconds
%% Three Cells are Taken
First_HeNB_Channel=10;
Second_HeNB_Channel=10;
Third_HeNB_Channel=10;
%% Distance coverage
First_HeNB_Coverage=10;%Meters, (Picocells are 200 meters)
Second_HeNB_coverage=10;%Meters, (Picocells are 200 meters)
Third_HeNB_coverage=10;%Meters, (Picocells are 200 meters)
%% Number of User Distribuation IN Femto Cells
NUM_User_First=20;
NUM_User_Second=20;
NUM_User_Third=20;
%% Percent of Simultaneously User Genarating Call
%First HeNB is the Femto_Cell
while(i<=10)    %Repetation of Transmission 10 Times
Percen_First=rand(1)*0.5*NUM_User_First %hold Resources(used)
Percen_Second=rand(1)*0.4*NUM_User_Second %hold Resources(used)
Percen_Third=rand(1)*0.2*NUM_User_Third %hold Resources(used)
%% Available Channel in First Cell for Old Scheme
R_AH(i)=First_HeNB_Channel-Percen_First %Available Resourses in
Hotspot
%% Available Channel in First Cell for New Scheme
R_TH(i)=R_AH(i)+(Second_HeNB_Channel-Percen_Second) ...
+(Third_HeNB_Channel-Percen_Third) %% Total Resources in Hotspot
i=i+1;
end
```

```

plot(R_TH/Total_channel,'b','linewidth',2); %Ru/Resources Utilized=
R_TH/Total_channel for new scheme
hold on
plot(R_AH/Total_channel,'r--','LineWidth',2); %Ru/Resources Utilized=
R_AH/Total_channel for old scheme
hold off
legend('Ru for adaptive hanoveralgorithm','Ru for conventional algorithm');
xlabel('Time in second');
ylabel(' Percent of Utilization ');
title('Compre of Resource Utilization for Two Schemes');
grid
% 1-Scheduling Dely Time
% New Scheme
Dt=0.02;%s -- Total time in current cell
Dc=rand(1,10).*ones(1,10);%ms %Delay in new Scheme in cell

% Old Scheme
N=2; %Number of cells

Delay1=Dc+Dt*N; figure(2) %Delay in old Scheme
plot(Delay1,'r','linewidth',2);hold on
plot(Dc,'b--','linewidth',2);hold off
legend('conventional scheme','adaptive handover time scheme ');
ylabel('ms'),title('Delay for Each Transmiision');
xlabel('time in second')
grid

% 2-Data Rate
% Old Scheme
M=0.6*rand(1,10); %Modulation Factor
C=0.9*rand(1,10); %Coding Rate
BW=20000000; %BandWidth in Old Scheme
Data_Rate1=BW.*M.*C.*ones(1,10);
tp1=sum(Data_Rate1(1,:)).*rand(1,10);
% New Scheme
R_H=N*(20000000-20000000.*0.9*rand(1,10));% Availabel in other Cold
Cells
BW=BW+R_H; %BandWidth in New Scheme
Data_Rate2=BW.*M.*C;
tp2=sum(Data_Rate2(1,:)).*rand(1,10); figure(3)

```

```

plot(Data_Rate2,'b--','linewidth',2)
hold on;
plot(Data_Rate1,'r','linewidth',2),hold off
legend('adaptive handover time scheme ','conventional scheme');
ylabel('bps'),title('Data Rate for Each Transmiision'); xlabel('time in
second')
grid
%%%%%%%%%%
figure(4)
plot(tp2,'b--','linewidth',2)
hold on;
plot(tp1,'r','linewidth',2),hold off
legend('adaptive handover time scheme ','conventional scheme');
ylabel('bps'),title('throughput');
xlabel('time in second')
grid
%3-Probability of Bolcking
Rt=30;          %Total Resource in System
%Old Scheme
Rh1=10*0.9*rand(1,10); %Resourse in Hotspot
POB1=(Rt-Rh1)/Rt; %Blocking Probability of old Scheme
%New Scheme
Rh2=10*0.8*rand(1,10)+(10*0.6*rand(1,10))+Rh1; %Resourse in hotspot
POB2=(Rt-Rh2)/Rt; figure(5) %Blocking Probability of new scheme
plot(POB1,'r','linewidth',2)
hold on;
plot(POB2,'b--','linewidth',2),hold off
legend('conventional scheme','adaptive handover time scheme');
ylabel('percentage of blocking'),
title('Probability of Blocking for Each Transmiision');
grid
xlabel('time in second')

%%%%%%%%%%packet delay%%
%capacity of the link
c=100;
%number of packets

k=10;

```

```

i=1;
w=1500.*rand(1,10).*ones(1,10); %w=h+lp(length of packet) in bytes
while(i<=k)
    %without the scheme
    pd1=(i.*ones(1,10).*w)./c;
    %%%with the scheme
    c2=100-(100*rand(1));%borrowing resources
    pd2=(i.*ones(1,10).*w)./(c+c2); i=i+1;
end
figure(6)
plot(pd1,'r','linewidth',2)
hold on;
plot(pd2,'b--','linewidth',2),hold off
legend('conventional scheme','adaptive handover time scheme');
ylabel('packet delay in ms'),
title('packet delay for Each Transmision');
grid
xlabel('packets number')

```