

بِسْمِ اللَّهِ الرَّحْمَنِ الرَّحِيمِ

Sudan University of Science and Technology

Collage of Engineering

Electrical Engineering

Flexible Braking Car Control System

**A project Submitted in Partial Fulfillment for the Requirement of
the Degree of B.Sc.(Honor) in Electrical Engineering**

Prepared By:

- 1. Abubaker Osman Ahmad Osman .**
- 2. Ahmed Bushra Ibrahim Mohammed .**
- 3. Mohamed Khalid Alageed abdalla .**
- 4. Nihad Atta Elmanan Hamza Mohammed Dongla .**

**Supervised By :
Gaffer Babiker**

October 2017

بِسْمِ اللَّهِ الرَّحْمَنِ الرَّحِيمِ

(وَقُلِ اعْمَلُوا فَسَيَرَى اللَّهُ عَمَلَكُمْ وَرَسُولُهُ وَالْمُؤْمِنُونَ وَسَتُرَدُّونَ إِلَىٰ عَالَمِ
الْغَيْبِ وَالشَّهَادَةِ فَيُنَبِّئُكُم بِمَا كُنتُمْ تَعْمَلُونَ)

سورة التوبة الآية (105)

DEDICATION

This project is lovingly dedicated to our respective parents who have been our constant source of inspiration. They have given us the drive and discipline to tackle any task with enthusiasm and determination. And as expected in every step in our career building, Without their love and support this project would not have been made possible.

ACKNOWLEDGEMENT

Project is like bridge between theoretical and practical working. in the accomplishment of this project successfully , many people have best owned upon me their blessings and support .

Primary we thank Allah for being able to complete this project with success . Then we would like to thank every engineer how gives us help or how giving us the information's that's we were need and all the staff working in the mechanic work-shop .

ABSTRACT

In the main and subway roads usually many accidents accrue from human wrongs careless, Or from physiologic situations or the problem vision, Or from the immediately stopping .

From the worst type of an accident's that had a high damage level which happened from the infront causes a dangerous injures or environmental damage.

It is kept to lead a study to build a control system to provide a front safety zone for the car and as try to minimize the accidents that's happens from the infront of the car.

It was built an emergency control system to brake the car by pulling the brake pedal ,The system select the car's stopping distance depending on the car speed , The system work at the speeds range (20 - 60) Km/h and specified to small cars which led by a hydraulic brake system for the cars models from 2010 to 2016 years.

All the lengths or dimensions measurements have been taken manually from a car model corolla 2016 year .

المستخلص

في الطرق الرئيسية و الفرعية تحدث الحوادث كثيرا من الاخطاء البشرية من قلة انتباه , او الحالة النفسية او من مشاكل الرؤية . او من التوقعات المفاجئة .

من أسوء أنواع الحوادث و أكثرها تسببا بالأضرار تلك التي تحدث من الجهة الأمامية للسيارة, من اصابات خطيرة و أضرار مادية .

تم دراسة لتصميم نظام يمنح مسافة أمان امامية للسيار كمحاولة لتقليل من الحوادث الأمامية للسيارة.

تم تصميم نظام طوارئ للتحكم في كبح السيارة عن طريق سحب دواسة الفرامل , النظام يختار المسافة المناسبة لكبح السيارة و يعمل للسرعات النطاق (20-60) كيلومتر في ساعة , و مخصص للسيارات الصغيرة التي تعمل بنظام فرامل هيدروليكي للسيارات من طراز 2010 الي 2016 .

جميع قياسها المسافات و الأبعاد التي تمت في هذه الدراسة تمت من سيارة طراز corolla 2016.

TABLE OF CONTENTS

No.	Content	Page No.
	الاية	i
	DEDICATION	ii
	ACKNOWLEDGEMENT	iii
	ABSTRACT	iv
	مستخلص	v
	TABLE OF CONTENT	vi
	LIST OF FIGURES	ix
	LIST OF TABLES	xiv
	LIST OF ABBREVIATIONS	xv
	LIST OF SYMBOLS	xvi
CHAPTER ONE INTRODUCTION		
1.1	Overview	1
1.2	Problem Statement	1
1.3	Objectives	2
1.4	Methodology	2
1.5	The project layout	2
CHAPTER TWO LETIRTIOR REVIW		
2.1	An Automatic Emergency Braking system	4
2.2	Mechanical Actuation and Low Level Control for a BMW X5 Automatic Safety System	7
2.2.1	The brake actuator	8
2.3	The Brake Actuator	11

2.3.1	Brake by Wire	11
2.3.2	Linear Actuation	12
2.3.3	Hydraulic Pressure	13
2.3.4	Overriding the BMW X5's Onboard Hydraulic Booster	14
2.4	Brake Actuator Selection Criteria	15
CHAPTER THREE		
THE HYDRAULIC BRAKE SYSTEM PRINCIPALS&COMPONENT		
3.1	Introduction	17
3.2	The Basic Physical principle's In Car Braking System	18
3.2.1	Leverage	18
3.2.2	Hydraulics system	18
3.2.3	Friction	21
3.3	The Brake Process in The Hydraulic Braking System	22
3.4	The Hydraulic Brake System Components	24
3.4.1	The brake pedal	25
3.4.2	Power Brake Unit	26
3.4.3	The master cylinder	28
3.4.4	The hydraulic line	30
3.4.5	Proportioning Valve	30
3.4.6	Front Disc Brakes	32
3.4.7	The Rear Drum Brakes	36
3.4.8	The Emergency Hand Brake	37
3.4.9	The Wheels and Tires	39
CHAPTER FOUR		
THE SYSTEM DESIGN		
4.1	Introduction	40
4.2	The Hardware Design	41

4.2.1	Place of Solenoid Actuator	42
4.2.2	Calculate the power required from the Solenoid	42
4.2.3	Displacement And Strength Of The Brake Pedal	43
4.2.4	Coil Design	44
4.2.5	The Core Material	47
4.3	The Sensor's Positions	48
4.4	The Software Design	49
4.5	The System Block Diagram	52
4.6	THE SOFTWARE & HARDWARE DESGINS ANLAYSIS	54
4.6.1	The hardware analysis	54
4.6.2	The Software Result Analysis	58
THE CHAPTER FIVE CONCLUSION AND RECOMMONDATION		
5.1	Conclusion	61
5.2	Future work	61
	REFERANCE	63
	APPENDIX A	65
	APPENDIX B	66
	APPENDIX C	68
	APPENDIX D	69
	APPENDIX E	71

LIST OF FIGURE

Figure No.	Title	page No.
2.1	Show The Basic Brake System Attached With Technology Of The AEBS (Automatic Emergency Braking System)	4
2.2	Show The Normal Brake System (Basic Brake System) Without The AEB Technology	5
2.3	REV BMW X5 Intelligent Vehicle Concept	7
2.4	The Servomotor Arm Brake Actuator	8
2.5	Measurement Rig for Measuring Torque vs. Rotation of Brake	8
2.6	Servomotor Mounting Bracket	9
2.7	Improved brake arm design	9
2.8	Brake by wire system rendering	11

2.9	Linear brake actuator through firewall	12
2.10	Linear brake actuator	12
2.11	Bosch DSC III hydraulic unit	14
3.1	A simple leverage	18
3.2	Simple hydraulic system	19
3.3	Master cylinder with two slaves of the hydraulic system	19
3.4	Hydraulic multiplication	20
3.5	A simple brake system	20
3.6	The fraction force versus weight	21
3.7	The microscopic level	21
3.8	hydraulic braking circuit	23
3.9	Master Cylinder Inside Section	23
3.10	Simple pedal	26
3.11	Vaccum Booster	27

3.12	Check Valve Of The Vacuum Booster	27
3.13	The Vacuum Booster In action model	28
3.14	Simple master cylinder	28
3.15	Modern Master Cylinder Instruction	29
3.16	Cases of car's load distribution	31
3.17	pressure distribution between rear and front wheel by Proportioning Valve	31
3.18	The Disc Brake Type	32
3.19	The Disc Brake Component's	34
3.20	The Disc Brake Pads	34
3.21	The Disc Brake Rotor	35
3.22	The disc brake caliper	35
3.23	The Drum Brake Type	37
3.24	The Hand Brake Of The Drum	38
3.25	The drum brake pads	38

3.26	The drum brake rotor	39
4.1	The solenoid actuator installation place	42
4.3	The brake pedal curve	43
4.2	The Theoretical Brake Pedal Force Curve	44
4.4	The wire's housing each other	45
4.5	The actual housing of wire's	45
4.6	The Magnetic Field In The Solenoid Core	46
4.7	The actuator structure design	48
4.8	The sensor places on the car	48
4.9	The Fuzzy Membership's function	50
4.10	Flow chart	51
4.11	System block diagram	52
4.12	The wiring circuit	53
4.13	The brake pedal working curve	54

4.14	The ideal solenoid working curve	55
4.15	The real working curve of the solenoid	55
4.16	The Brake Pedal Working Curve Vs. The Solenoid Curve	56
4.17	The Pedal and Solenoid Working Curve After The Improvement	57
4.18	The final actuator structure after correction	57
4.19	The result of The fuzzy system simulation	58
4.20	The braking distance experimental result	59
4.21	Fuzzy system output Vs. experimental Results	60

LIST OF TABLES

Table No.	Title	Page No.
2.1	Comparison and selection of brake actuator	15
4.1	Experimental and simulated values of the stopping distance	49

LIST OF ADDREVICTIONS

ECU	Electronic Control Unit
AEBS	Automatic Emergency Braking System
BMW	Bavarian Motor Work
PID	Proportional Integrated Devices
ABS	Antilock Brake System
ESP	Electronic Stability program
DOT	Department Of Transportation
EVBP	Electric Variable Brake Propitiation
SD	Stopping distance

LIST OF THE SYMBOLS

M	Mass , Kg
G	Acceleration, m/s^2
F_r	Rotor output force, N
P	Pressure, Ps
F	Force, N
N	Turns number's
L	Length ,m
W	Weight ,gm
R	Resister , Ω
D	Diameter ,m
A	Area , m^2
μ_r	relative permeability
μ_o	Air gab relative permeability
i	Current , Amp
n	Turn's number
L_g	Air gab length . m
μ	Brake factor
r	Rolling radius , m
d	Dominator ,m
Kv	The kinetic energy , joule
V	Velocity, m/s

CHAPTER ONE

INTRODUCTION

1.1 Overview

Driving is a compulsory activity for most people. People use their car to move from one place to other place. The number of vehicles is increasing day by day.

Nowadays, accidents are increasing and are uncertain. Accident will occur every time and everywhere and cause worst damage, serious injury and even death. These accidents are mostly caused by delay of the driver to hit the brake. This project is designed to develop a new system that can solve this problem where drivers may not brake manually but the vehicles can stop automatically by detecting obstacles. This project is about a system that can control braking system for safety. Using ultrasonic as a ranging sensor, its function based on ultrasonic wave. After transmitting by transmitter, the wave can reflect when obstacle is detected and then received by receiver. The braking circuit's function is to stop the car automatically after receiving signal from the sensor [1].

1.2 Problem Statement

It was found that the Crashes throughout the United States .Data is weighted to provide a nationwide estimate of all types of crashes and injuries. Focusing on light vehicle crashes in the NASS/GES database, show that rear-end collisions are most frequent among all crash types accounting for 29% of all crashes. Approximately 50% of all impacts are to the front of the vehicle. Frontal impacts into an opponent motor vehicle's rear end account for 6-9% of the total share.

In Germany approximately 12% of all accidents with persons injured and approximately 20% of all material damage accidents are caused by cars in rear end collisions [1].

1.3 Objectives

The main objective of this study is design an effective control system to:

- Develop the brake system of the automatic car at the emergency situation's .
- Give a safety zone in front the car to reduce the capability of crashing with the in front car .
- The system work to prevent anything in front the car that could be (human's , animal's , ... etc) and save their life .
- Reduce the crashes damage in the some crash's situation's that couldn't prevented .

1.4 Methodology

This project to the type of car's which control processes by a microcontroller name as ECU (Electronic control unit) .the car's processes which managed by ECU is needed to study car's brake system and the speed control by fuel system . this project has mechanic and electronic typical .`

A simulation-based project in which simulation of control system fuzzy membership's for saving a safety zone between car and any near thing which are in front of car or behind it.

1.5 The project layout

This project consists of an abstract and five chapters . chapter one ideal with an introduction include the overview , problem statement , methodology and project layout . chapter two ideal with a literature review represents an automatic emergency braking systems and mechanical actuation and low level control for a BMW X5 . chapter three ideal with the hydraulic brake system consists of the basic physicals principles in a car braking system and the hydraulic brake system components . chapter four ideal with the system design (hardware and software) ,

results and analysis of the system . chapter five ideal with the conclusion and the recommendations in future work .

CHAPTER TWO

Literature Review

2.1 An Automatic Emergency Braking System

Sushil kumar & Vishal Kumar had had study in an autonomous road vehicle safety system which employs sensors to monitor the proximity of vehicles in front and detects situations where the relative speed and distance between the host and target vehicles suggest that a collision is imminent. In such a situation, emergency braking can be automatically applied to avoid the collision or at least to mitigate its effects. The system will disengage if the system detected that an action was taken to avoid the collision this is determined by peizometric sensor which is placed at the paddles as shown in the figure (2.1).

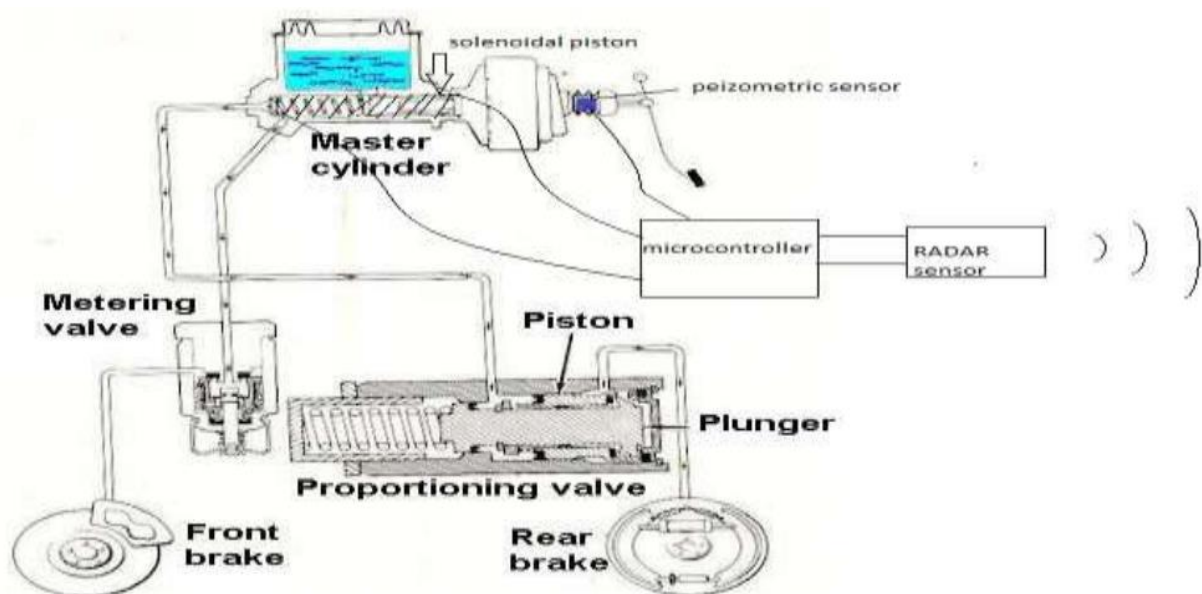

Figure 2.1: Show the basic brake system attached with technology of the AEBS (Automatic Emergency Braking System)

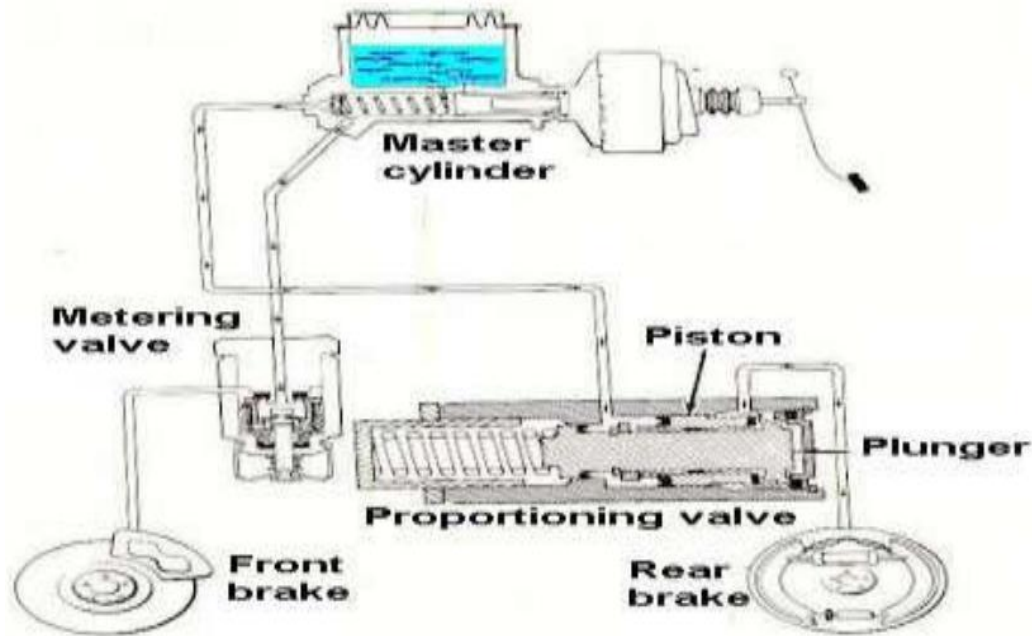

Figure 2.2: Show the normal brake system (basic brake system) without the AEB technology

Further the idea is moved further ahead by developing the innovation of making the piston of the master cylinder to work under the solenoid coils. This can be done by wrapping the wires around the master cylinder. as shown in the figure (2.1) Once the sensor sends and receives the signal after striking the obstacle it can judge the relative distance between the vehicles by noting the time taken for this (DOPPLER'S EFFECT) and by repeatedly doing this it can also determine the relative speed of the vehicle and obstacle, Once these two things are known to the controller it can judge whether the accident will take place or not. if yes then the different level of forces depending upon the relative distance of the vehicle can be obtained by varying the current through the solenoid as directed by the controller .The piston which is made of metal experience the LORRENTZ FORCE and accordingly the requisite pressure will develop around the wheels to apply the brakes [2].

Let us consider a vehicle approaching a bump at a distance of 2m instantaneously at 90km/hr or 25m/s.

It is impossible for human to react in a time of $2/25 \text{ sec} = 0.08\text{sec}$

But if an AEBS is installed, reaction time = Total distance travelled

$$2 \times X / 3 \times 10^6 = 1.33 \times 10^{-6} \text{ sec}$$

So that

$$1.33 \times 10^{-6} \text{ sec} \ll 0.08 \text{ sec}$$

(with AEBS) (without AEBS)

Automotive radar systems are usually situated behind the grille. Radio waves sent out by the radar are partially reflected back by metallic objects, such as cars. By measuring the time the echo takes to arrive AEB can figure out how far away an object is. Radar reflections off moving objects will exhibit a Doppler shift, which allows the system to calculate the speed of the object. Radar works well for long range scanning. In -car systems are able to “see” between 80 and 200 meters down the road and work at speeds of up to 200km/h or even more [2].

Some systems combine or fuse radar-based detection with information gathered by a camera system. Subaru, uniquely, uses cameras exclusively. Its Eyesight system uses two widely spaced cameras mounted high on the windscreen to imbue equipped cars with stereoscopic vision. At these higher speeds, if an AEB-equipped car thinks that a crash is highly likely the system will pre-arm the brakes, and warn the driver via audio alerts, as well as flashing lights and messages on the instrument panel. Should the driver undertake no evasive action, some systems will prompt the driver one more time by either pulsing the brake pedal or tugging repeatedly at the seatbelt. If the brake-pedal remains unsullied or the steering wheel un moved, the AEB system will then apply the brakes; usually gently at first, then at maximum pressure if there’s still no driver interaction. As with city-based lidar systems, each manufacturer with their own version of radar and/or

camera -based AEB markets it under a different name. Mitsubishi calls it Forward Collision Mitigation, Skoda has Front Assistant, A-udi's system is called Pre Sense Front, there's also Volkswagen's Front Assist and Lexus models have Pre-Collision Braking, just to name a few [2].

2.2 Mechanical Actuation and Low Level Control for a BMW X5 Automatic Safety System

Matthew Webster, In these study investigation is led to build an automatic safety control system for car type of BMW X5 which is clear in the figure (2.3).[3]

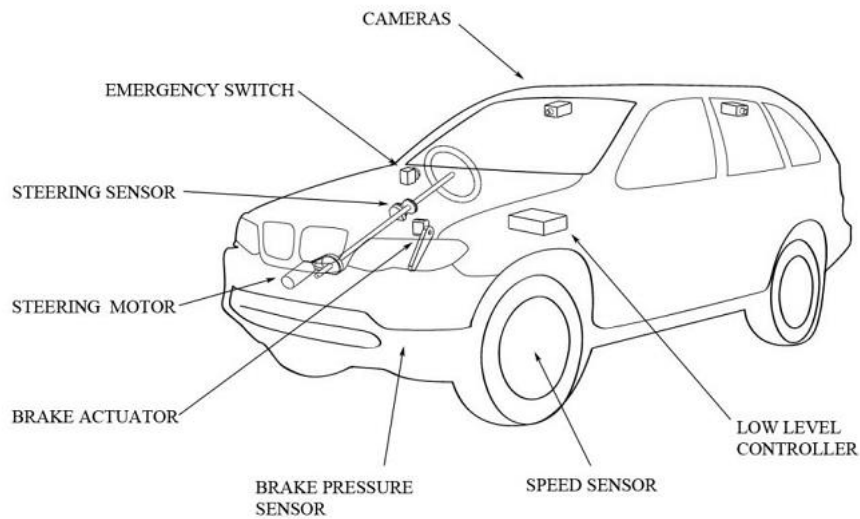

Figure 2.3:REV BMW X5 intelligent vehicle concept

It use a servomotor attached with arm to the brake pedal it clear in the figure (2.4),

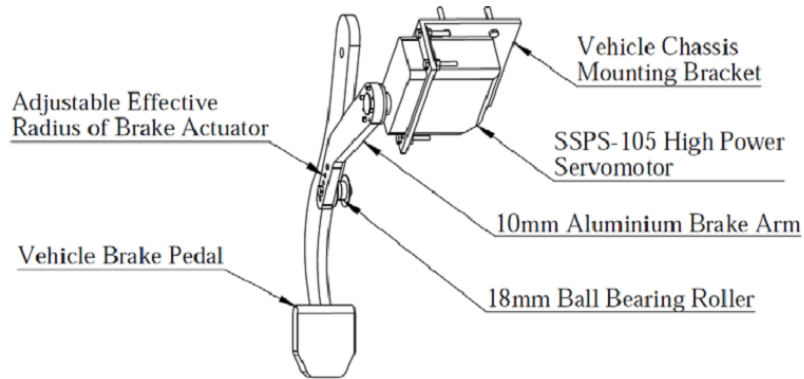

Figure 2.4: The servomotor arm brake actuator

Which controlled by Arduino UNO controller, the controller is programmed by PID control algorithm, and some sensors was attached for giving the system needs for working.[3]

- The brake actuator

The rotation and torque measurement were taken using an experimental rig, shown in the figure (2.5) ,

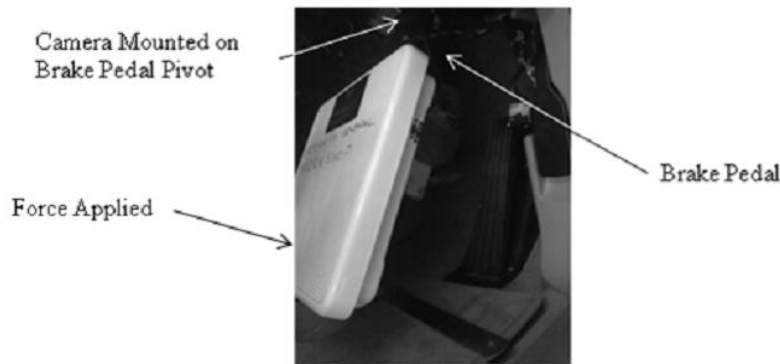

Figure 2.5: measurement Rig for measuring torque vs. rotation of brake

A camera was amounted to the brake pedal pivot and force applied though mass scale. A vertical string was fixed to the body of the vehicle, through the centre point of the camera's line of site to enable calculation of the angular difference using video frames. [3]

The maximum brake rotation required to stop vehicle which 13° , correlating to a torque of 37 Nm. which was confirmed with mass scale reading of 13 Kg. And the length of the pedal was measured to be 290 mm. This value was used for all subsequent calculations.[3]

The SSPS-105 servomotor datasheet shows an operating speed of 0.95 seconds per 90° , which for a 13° rotation equates to a time of 0.14 seconds.[3]

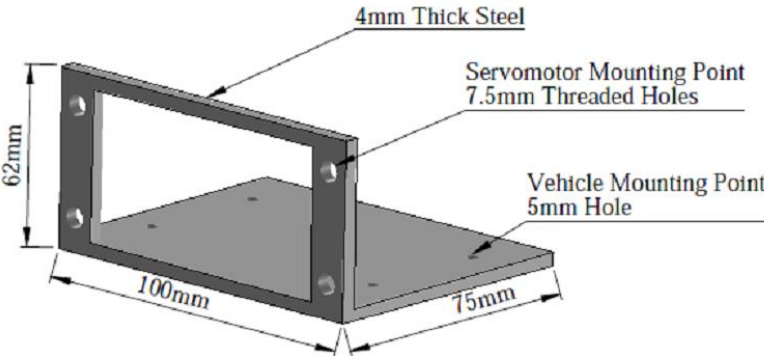

Figure 2.6: Servomotor mounting bracket

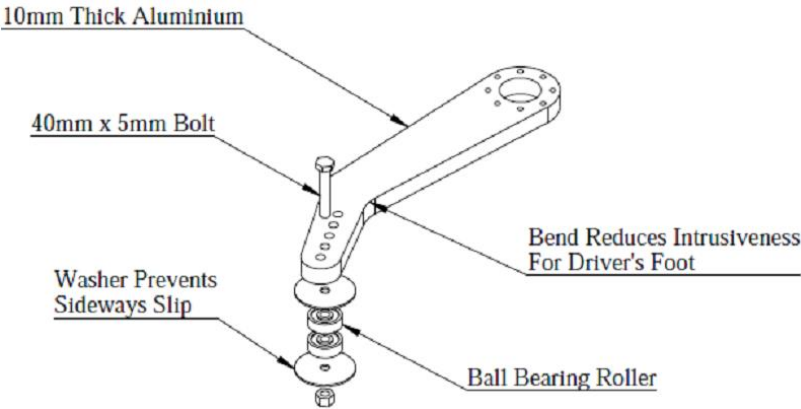

Figure 2.7: Improved brake arm design

The revised design includes an adjustable roller position along the length of the brake actuator arm and a bend which is intended to reduce intrusiveness in normal brake operation. Having an adjustable length allows modification of the torque & speed characteristics of the servomotor arm. An adjustable ball bearing roller was

installed on the servomotor arm for contact with the brake pedal. The rollers use washers to ensure that sideways slip doesn't occur.[3]

It is essential to retain driver control of the vehicle, especially the braking system which is the most fundamental safety element of a vehicle. If the servomotor were designed to be fixed to the brake pedal, and not allow forward movement, then there would be a considerable risk of damaging the vehicle and its occupants or external environment including other vehicles, structures and pedestrians. Two major factors mitigate this risk eventuating.[3]

- The design is such that the brake is always able to be pressed further by the driver.
- To deactivate the brake actuator an emergency switch and appropriate circuitry to reset the servo position, and cut power to the device.

Their two key points of failure of the device . First, is the risk the arm becomes dislodged over time, falls off and gets caught within the pedals, preventing normal brake operation by the driver. Second, is the risk that the servomotor may dislodge from the mounting bracket. To lower the likelihood of both these risks eventuating, locking washers were used for all connections to reduce the possibility of any loosening occurring over time. The design was also implemented with many bolt connections for both the brake arm and servomotor bracket, increasing the reliability of connections between components.[3]

- The design actuator safety

The design is relatively safe, allowing for increased brake pressure by the driver in any situation, and deactivation of the brake servomotor using an emergency switch.[3]

The overall design ensures that an average human driver's foot won't contact the servomotor brake actuator system. The system can be easily removed and no

major modifications to the vehicle chassis were required to install it. The cabin's inner panel sits between the servomotor and driver, effectively hiding the servomotor from view and contact.[3]

2.3 The Brake Actuator

In these study it was undertaken to investigate the various brake actuation options available, which Brake Actuator :

Included brake by wire, linear actuation , hydraulic pressure and overriding the BMW X5's onboard hydraulic brake booster [3].

2.3.1 Brake by Wire

One solution for brake actuation, proposed by Shah, 2009 and shown in Figure (2.8) is to use a servomotor, positioned between the firewall and brake pedal in combination with a cable and pulley to apply a pulling force on the brake.

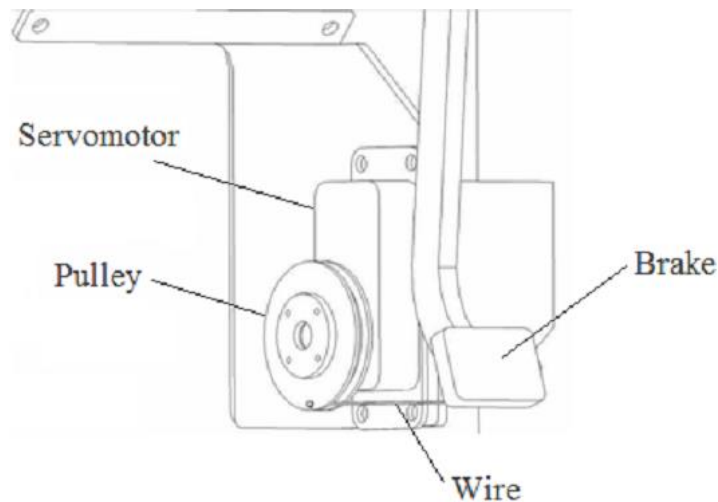

Figure 2.8: Brake by wire system rendering

This system was shown by Shah to be a viable solution, and relatively easy to implement.[3]

2.3.2 Linear Actuation

A solution for linear actuation of the brake was previously implemented by the Golem Group in the DARPA entry in 2006. A linear actuator could be placed behind the brake pedal, through the firewall of the vehicle as shown in figure (2.9) , Several issues are present in this design, such as the problem of mounting an actuator in the engine bay, cutting through the firewall and possible interference with normal operation of the brake [3].



Figure 2.9: Linear brake actuator through firewall

An alternative linear actuation method is shown in Figure (2.10) Proposed by Shah, 2009.

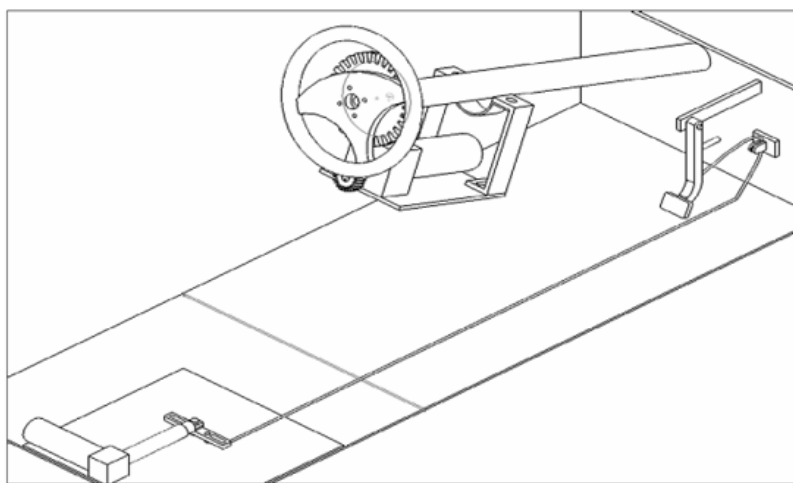

Figure 2.10: Linear brake actuator

A linear actuator would be placed under the seat, and a wire cable arrangement used to actuate the brake. Whilst this is a viable solution, a stroke reduction system is necessary which adds complexity to the system [3].

2.3.3 Hydraulic Pressure

Direct control over a vehicle's hydraulic brake system was previously used by Prohaska & Devlin, 1998 to control the braking system for automatic vehicle research. An investigation found a commercially available device, the HydraStar XL, which is capable of electronically controlling a hydraulic pressure line to actuate the braking system of trailers. This system could be installed into the brake line of the BMW X5, thereby facilitation electronic control over the brakes. Some advantages to such a system were that it would be out of sight, and fairly easy to implement [3].

2.3.4 Overriding the BMW X5's Onboard Hydraulic Booster

The first method was to deconstruct the hydraulic unit, shown in Figure- (2.11):

Bosch DSC III 5.7 Hydraulic Unit

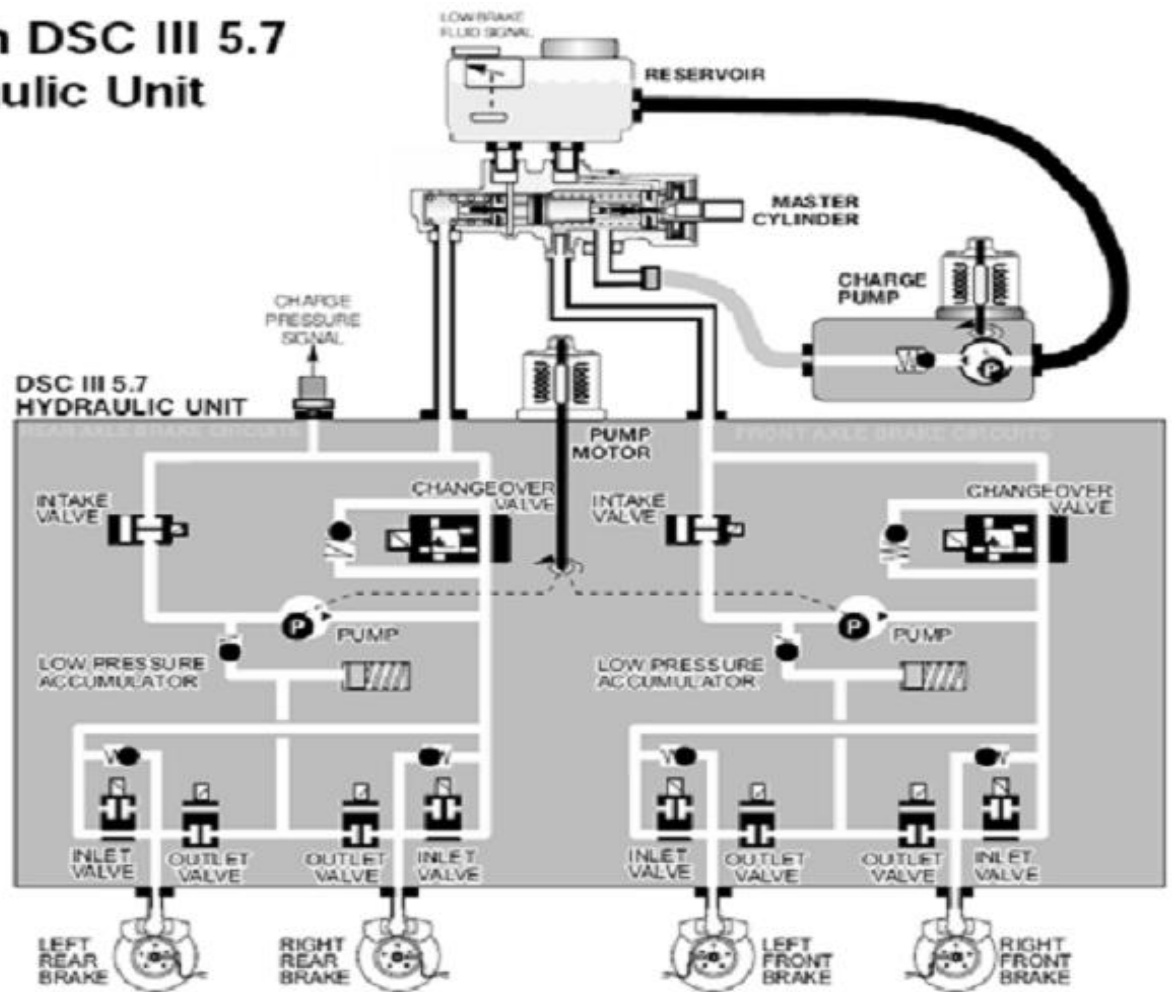

Figure 2.11: Bosch DSC III hydraulic unit

Take control of the system's valves and charge pump. This would pose some serious safety and implementation issues so this solution was not investigated further [3].

The second method investigated was to hijack the vehicle's speed sensor and provide a modified signal in order to manipulate the onboard stability control system. The theory being that if a spike in speed is detected, the BMW's traction control system will apply the brakes to regain traction with the road [3].

2.4 Brake Actuator Selection Criteria

Selection of the brake actuator solution was based on the following criteria [3]:-

- Safety of the car and passengers.
- Unobtrusive to the driver and preserves normal functionality of the vehicle.
- Reliable control and actuation.
- Effective brake actuation.
- Relatively easy to implement.
- Compatibility with an electronic controller.
- Reasonable level of accuracy.

2.5 Comparison and Selection of Brake Actuator Type

The following table is a comparison of the various systems that were considered is shown in the table 2.1 [3].

Table 2.1: Comparison and selection of brake actuator

<i>Actuator</i>	Safety	Unobtrusive and Retains Normal Functionality	Reliability	Effective Actuation	Easy to Implement
Servomotor Arm	Good	OK Might interfere with driver's foot. Prevents release of brake	Good	Good	Good Servomotor available, bracket easily fabricated
Servomotor Pull by Wire	Good	Good Prevents release of brake	Good	OK May be slow due to pulley	Good Servomotor available, pulley easily fabricated
Hydraulic Pressure	OK Must alter	Good Prevent release of	OK May require	Good But may	OK May be messy

	hydraulic system	brake but very unobtrusive	maintenance	have limits on activated duration	to implement, commercial unit may not be suitable
Linear Actuator	OK More parts & modification necessary	OK Will interfere if fixed through firewall	OK More parts, weaker actuator	OK May be slow & power issues	OK Design requires extra mounting points and parts
Override BMWs Braking System	Bad Must trick current braking safety system, dangerous	Bad Modifies normal functionality of onboard safety systems	OK If functional, probably reliable	Good If functional, will be capable of actuation	Bad Requires special circuitry & extensive testing
The solenoid actuator	Good It applied a fully braking quickly which requires to use seat belt	Not Bad it is need a type of mechanical connection with inner car body to attached & needs to take the pedal movement space in the account	Ok Reliable & Very low maintenance (it has a simple an robust saturation)	Ok It work with high force and speed of actuation	Bad It requires one type of enameled wire specified to make & special core material

CHAPTER THREE

THE HYDRAULIC BRAKE SYSTEM

PRINCIPALS&COMPONENT

3.1 Introduction

A brake is a mechanical device which inhibits motion. Basically the brake system converts the kinetic energy of vehicle motion into heat (thermal energy). When the brake designed there are two challenges will faced which is create an enough deceleration to stop the car as quickly as the driver wishes, without exceeding the drivers comfort level with regard to pedal effect or pedal travel ...And mange the resulting heat energy so as not to damage the brake system or the rest of the vehicle. It was known that the proportional with the square of speed from the expression ($KV = MV^2 / (2 * G) \quad N-M$) [8].

There are a many types of brake system , A hydraulic system which use a liquid (special oil) to push the calipers unit to have a brake .and also A pneumatic brake system which use air [8].

This chapter is take a light of a basic hydraulic brake system what it's component's and it's working physical principle's and its basic process.

3.2 The Basic Physical principle's In Car Braking System

As we know when we step the brake pedals or handbrakes, the cars transmit the force from our feet or hands to the brakes. Because the brakes need a much greater force than drivers could apply with legs, the car must multiply the force of the foot. How could it be achieves? These two physics principles could be used:

Leverage and Hydraulic system. And how do the brakes transmit the force to the tires? How do the tires transmit the force to the road? Both answers are using friction. Therefore, this part will introduce these three physics principle by first: Leverage, Hydraulics, Friction:

3.2.1 Leverage

As the figure (3.1)

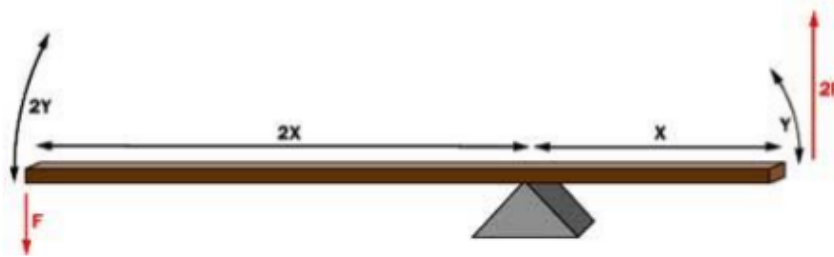

Figure 3.1: A simple leverage [4]

Shows, there is a force applied on the left end of the lever. The length of the left end is twice ($2X$) as long as the right end (X). Therefore, there is a force $2F$ on the right end. And it acts via the distance (Y), while the left end moves twice ($2Y$) as long as the right end. Consequently, with the change of the relative lengths of the left and right ends of the lever, the multipliers are also changing [4].

That refers to the theory of the summation of torque around a fixed point is equal to zero. and the rotation torque is proportion with the amount of force's which applied in the fixed point axis and also proportion with spacing that force's from that point [4] .

3.2.2 Hydraulics system

In addition, a hydraulic system is applied the brakes. The hydraulic system connects the brake pedal to the brake parts at each wheel [5].

The basic hydraulic system principle is simple. We can regard it as a process that force applied at one point is transmitted to another point by using an incompressible fluid, which almost always is an oil of some sort[6]. figure (3.2):

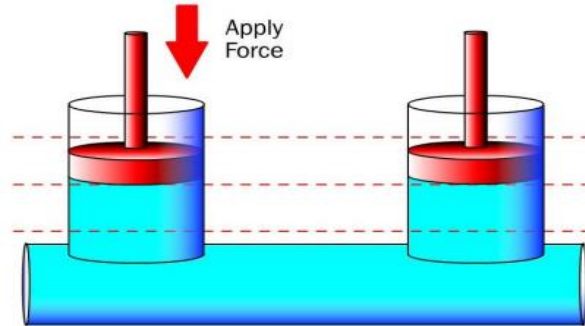

Figure 3.2: Simple hydraulic system [5]

Shows, 2 pistons (shown in red) are fitted into two oil-filled glass cylinders (shown in light blue) and connected to another one with a pipe filled with oil. When a downward force is applied to a piston, then the force is transferred to another piston via the oil in the pipe. The oil is almost incompressible, so that the transfer efficiency is high [6].

And one advantage of the hydraulic system is that the pipe can be any length and shape, therefore it could snake through all sorts of components separating the two pistons. The pipe can also fork, so that one master cylinder can drive many slave cylinders if need [5].

In figure (3.3)

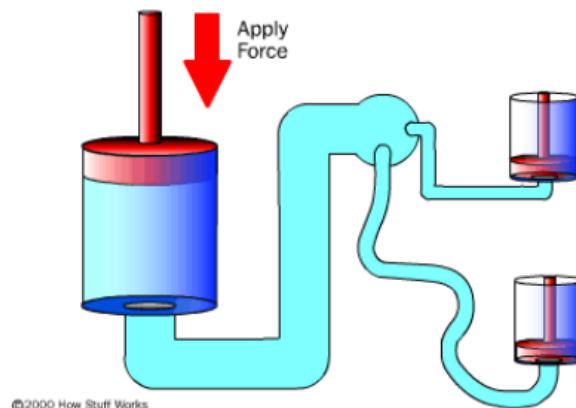

Figure 3.3: Master cylinder with two slaves of the hydraulic system [6]

The master cylinder drives two slave cylinder. One of the advantages of the hydraulic system is that it is easy to achieve force multiplication or fore division. In a hydraulic system, you just need to change the size of one piston and cylinder relatively.

We have to make shower than the oil amount is constant [5].

For Example In the figure (3.4) :

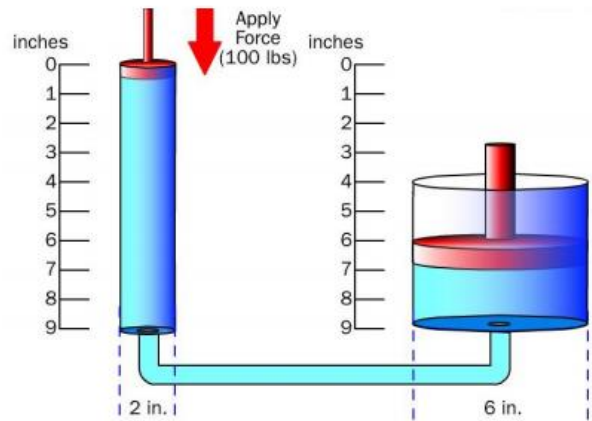

Figure 3.4: Hydraulic multiplication [5]

Because the liquid is pushed in closed structure and fixed cylinder's position so that the pressure is to be equal in the two connected cylinder's .Because the pressure is proportion with the area and with liquid's pushing force ,when the area is constant (can't change unless system structure is changed) so than the (Pressure = Force/area) from that ($p=F_a/A_a =F_b/A_b$) [5] .

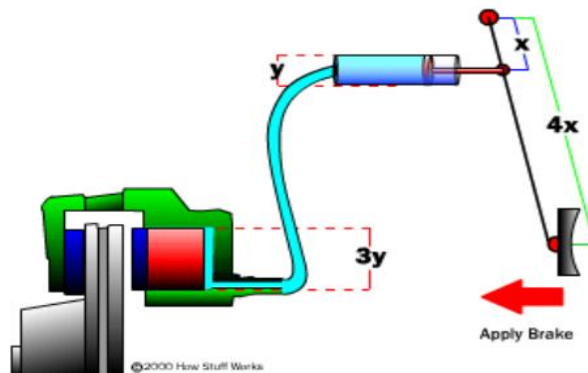

Figure 3.5: A simple brake system [5]

3.2.3 Friction

Friction is measured on how hard it is to slide one object over another .the friction is increase with the weight of the bodies (proportion with it's weight exactly) [4]. In the figure (3.6):



Figure 3.6: The fraction force versus weight

Although that the two blocks from the same material, will find that the friction in the heavier one is greater [4].

To understand why this is, let's take a close look at one of the blocks and the table:

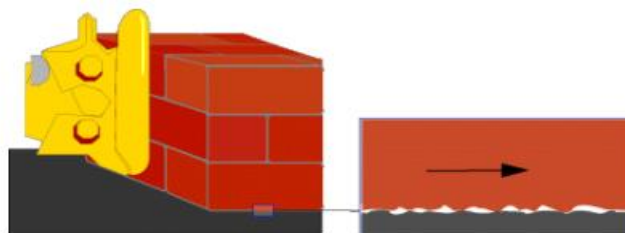

Figure 3.7: The microscopic level

The blocks look smooth to the naked eye, but actually they are quite rough at the microscopic level. When the block is set down on the table, the little peaks and valleys get squished together, and some of them may actually weld together. The weight of the heavier block causes it to squish together more, so it is even harder to slide [4].

So the amount of force it takes to move the given block is proportional to that block's weight. The more weight, the more force is required. Different materials have different microscopic structures, for instance, it is harder to slide rubber against rubber than it is to slide steel against steel. The type of material determines the coefficient of friction, the ratio of the force required to slide the block to the block's weight [4].

This concept applies for devices like brakes and clutches, where a pad is pressed against a spinning disc. The more force that presses on the pad, the greater the stopping force [4].

- Coefficients

An interesting thing about friction is that it usually takes more force to break an object loose than to keep it sliding. There is a *coefficient of static friction*, where the two surfaces in contact are not sliding relative to each other. If the two surfaces are sliding relative to each other, the amount of force is determined by the *coefficient of dynamic friction*, which is usually less than the coefficient of static friction [4].

For a car tire, the coefficient of dynamic friction is much less than the coefficient of static friction. The car tire provides the greatest traction when the contact patch is not sliding relative to the road. When it is sliding (like during a skid or a burnout), traction is greatly reduced [4].

3.3 The Brake Process in The Hydraulic Braking System

When the driver step on the brake pedal, he is actually pushing against a plunger in the master cylinder which forces hydraulic oil (brake fluid) through a series of tubes and hoses to the braking unit at each wheel. Refer to figure (3.8):

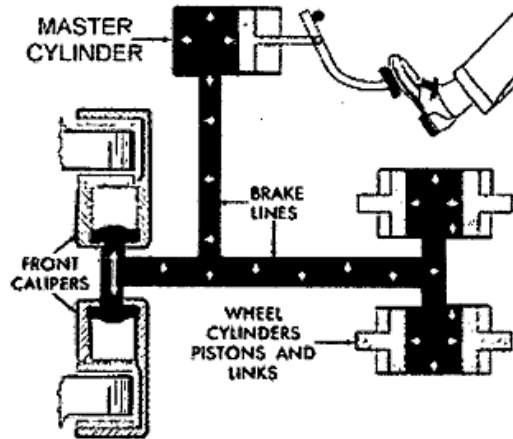

Figure 3.8: hydraulic braking circuit [7]

In a normal brake system, the whole system is interconnected and filled with fluid up to the upper part of the master cylinder reservoir. Refer to the figure (3.9):

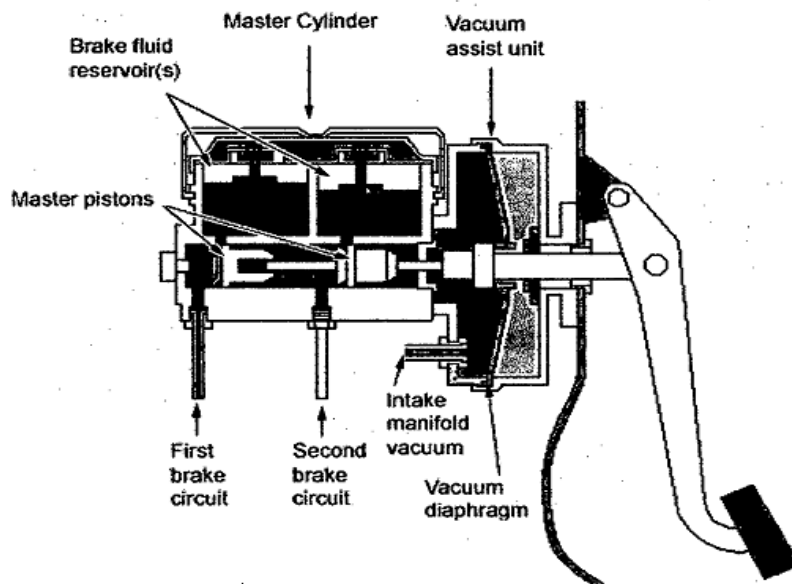

Figure 3.9: Master cylinder inside section [7]

The reservoir is vented to the atmosphere so fluid can expand and contract and still stay at atmospheric pressure. When the fluid in the wheel cylinders and calipers gets hot, it can expand and move through the open compensating port to the reservoir. When it cools and contract, it can move the other way, cylinders use a rubber diaphragm over the reservoirs to separate the fluid from air and to help

reduce fluid contamination. When sufficient force is placed on the brake pedal to overcome the piston return spring, the master cylinder piston will move inward. Fluid from the bore will be displaced to the reservoir until the lip of the primary cup moves past and closes the compensating port [7].

From this point further force and movement of the brake pedal will displace fluid to the system and move the brake shoes into contact with the rotors. Lining contact will stop further movement of the shoes and wheel cylinder or caliper pistons. From this point, system pressure will increase. Any increases in pedal force will cause a corresponding increase in wheel cylinder and lining pressure [7].

When the brake pedal is released, the piston return spring will move the piston very rapidly back to its stop at the retaining ring, much faster than the fluid will return from the wheel cylinder or calipers. During the motion, the primary cup will collapse or relax its wall pressure slightly and moves through the fluid. There will be a flow of fluid past the edges of the primary cup. Some pistons have a series of holes in the primary cup face to improve this flow [7].

On a disk brake, the fluid from the master cylinder is forced into a caliper where it presses against a piston. The piston, in-turn, squeezes two brake pads against the disk (rotor) which is attached to the wheel, forcing it to slow down or Stop [7].

3.4 The Hydraulic Brake System Components

The braking system of a modern vehicle is usually divided into four sub-systems to make all the engineering a little more manageable [8].

The Four Sub-systems:

- Actuation sub-system :-
 - The brake pedal
 - The power brake booster
 - The master cylinder

- The hydraulic control valve
- The hydraulic lines
- Foundation sub-system :-
 - The front disc brakes
 - The rear drum brakes
 - Brake lining.
- Parking brake sub-system
- ABS(Antilock Brake System) & ESP (Electronic Stability Program) sub-system

There are four main parts that involves in car disc brake system. All this part is important to make the car stop. The main parts are master cylinder, power booster, disc brake, and steel lines. The other parts are caliper, brake pads, and rotor. To make the function of this parts works, the brake fluid also included in this braking system. At this days technologies and the a lots of using of cars it's can says[8].

The major components:-

- The brake pedal
- The power brake booster
- The master cylinder
- The Proportioning Valve
- The hydraulic lines
- The front & rear brakes

3.4.1 The brake pedal

The brake pedal is a simple lever. The fulcrum is at the top of the pedal arm, the input is at the opposite end, and the output is somewhere in between. For example, a driver input force of 100 N is multiplied by a 4:1 ratio into 400 N of output force. This output force becomes the input force for the power brake unit or booster. The

travel of the drivers foot will of course be 4 times the travel of the booster input pushrod [8].

Pedal ratios on most vehicles today vary between 3:1 and 5:1 .

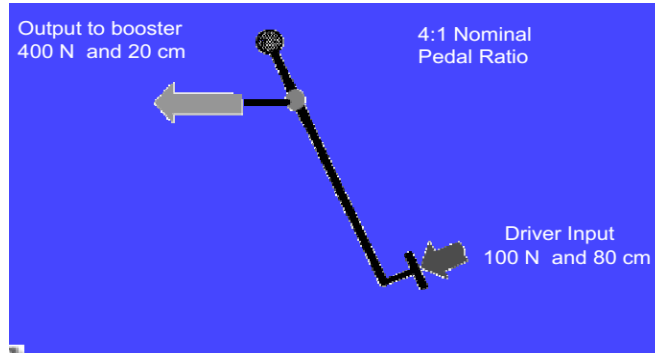

Figure 3.10: Simple pedal

3.4.2 Power Brake Unit

Almost cars this days has power assisted brakes, some systems use hydraulic or electro-hydraulic methods of power assist [6].

The power brake booster is mounted on the firewall directly behind the master cylinder and, along with the master cylinder, is directly connected with the brake pedal. Its purpose is to amplify the available foot pressure applied to the brake pedal so that the amount of foot pressure required to stop even the largest vehicle is minimal [6].

The vacuum power assist unit which use in most car's this days. it is uses the vacuum from the engine to multiply the force that your foot applies to the master cylinder .the vacuum power assist (can named also vacuum booster) is a metal canister that contains a clever valve and a diaphragm. A rod going through the centre of the canister connects to the master cylinder's piston on one side and to the pedal linkage on the other [6].

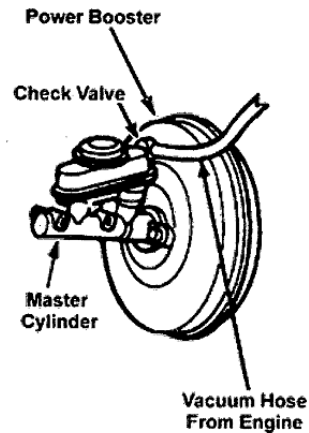

Figure 3.11: Vacuum Booster[7]

In figure (3.12):



Figure 3.12: Check Valve Of The Vacuum Booster [6]

Shows the check valve, which is a one-way valve that only allows air to be sucked out of the vacuum booster. If the engine is turned off, or if a leak forms in a vacuum hose, the check valve makes sure that air does not enter the vacuum booster [6].

The vacuum is a very simple, elegant design. The device needs a vacuum source to operate in petrol powered cars, the engine provides a vacuum suitable for the boosters, Because diesel engines don't produce a vacuum, diesel-powered vehicles must use a separate vacuum pump [6].

In Action

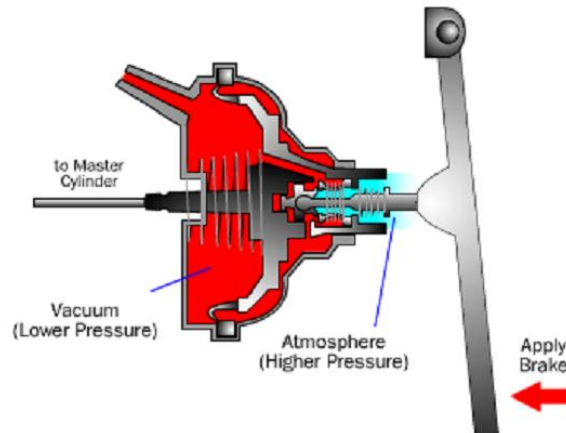

Figure 3.13: The Vacuum Booster In action model [6]

The engine creates a partial vacuum inside the vacuum booster on both sides of the diaphragm. When you hit the brake pedal the brake pedal pushes a rod that passes through the booster into the master cylinder, actuating the master-cylinder piston, the rod cracks open a valve, allowing air to enter the booster on one side of the diaphragm while sealing off the vacuum. This increases pressure on that side of the diaphragm so that it helps to push the rod, which in turn pushes the piston in the master cylinder [6].

As the brake pedal is released, the valve seals off the outside air supply while reopening the vacuum valve. This restores vacuum to both sides of the diaphragm, allowing everything to return to its original position[6].

3.4.3 The master cylinder

The master cylinder is a simple piston inside a closed end cylinder. It converts the motion of the brake pedal into hydraulic pressure [8].

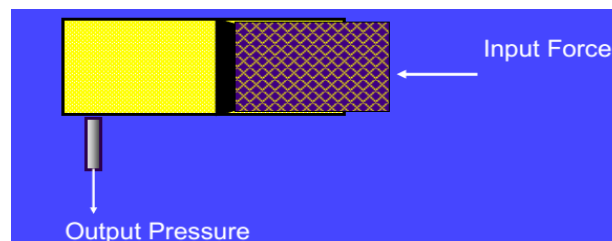

Figure 3.14: Simple master cylinder [8]

It consists of the reservoir tank, which contains the brake fluid, and the piston and cylinder which generate the hydraulic pressure [8].

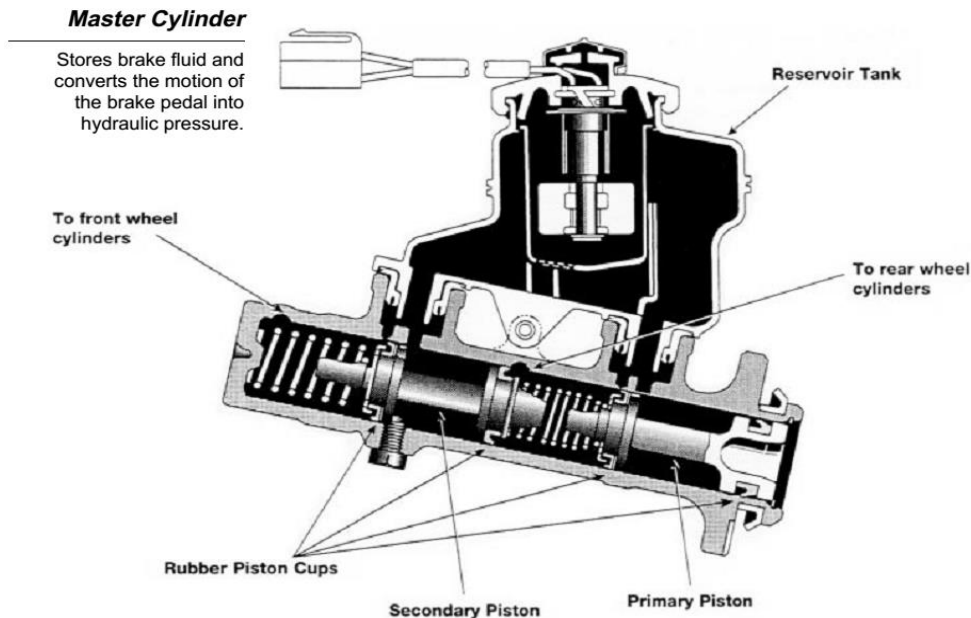

Figure 3.15: Modern Master Cylinder Instruction

When the pedal output rod pushes on the piston, the piston moves within the cylinder and pushes against the fluid and creating hydraulic pressure.

The pressure between the primary and secondary piston forces the secondary piston to compress the fluid in its circuit. If the brakes are operating properly, the pressure will be the same in both circuits. The pressure generated at the master cylinder is equal to the amount of force from the brake pedal output rod divided by the area of the master cylinder piston [7].

From the equation :-

$$P = \frac{F_{\text{PEDAL OUTPUT}}}{A}$$

Where F pedal output = Output force of brake pedal (N)

A = Area of the master cylinder piston (m²)

An electronic sensors within the master cylinder are used to monitor the level of the fluid in the reservoirs [7].

If there is a leak in one of the circuits, that circuit will not be able to maintain pressure [7].

3.4.4 The hydraulic line

- Brake Lines

The brake fluid travels from the master cylinder to the wheels through a series of steel tubes and reinforced rubber hoses. Rubber hoses are only used in places that require flexibility, such as at the front wheels, which move up and down as well as steer. The rest of the system uses non-corrosive seamless steel tubing with special fittings at all attachment points [7].

- Brake Fluid

Brake fluid is a special oil that has specific properties. It is designed to withstand cold temperatures without thickening as well as very high temperatures without boiling. (If the brake fluid should boil, it will cause you to have a spongy pedal and the car will be hard to stop.) Brake fluid must meet standards that are set by the Department of Transportation (DOT). The current standard is DOT-3 which has a boiling point of 460A0F 7].

3.4.5 Proportioning Valve

The proportioning valve reduces the pressure to the rear brakes. Regardless of what type of brakes a car has, the rear brakes require less force than the front brakes. The proportioning valve balances front-to-rear braking action during high deceleration stops and prevents premature locking of the rear wheels.

The amount of brake force that can be applied to a wheel without locking it depends on the amount of weight on the wheel. More weight means more brake force can be applied. If you have ever slammed on your brakes, you know that an

abrupt stop makes your car lean forward. The front gets lower and the back gets higher. This is because a lot of weight is transferred to the front of the car when you stop. Also, most cars have more weight over the front wheels to start with because that is where the engine is located [8].

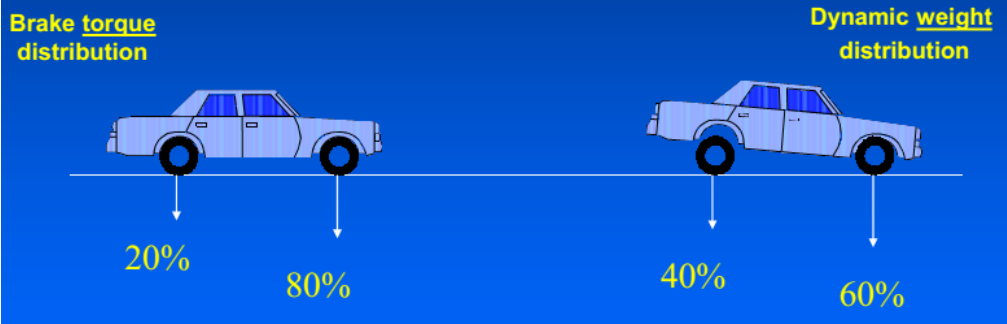

Figure 3.16: Cases of car’s load distribution [8]

If equal braking force were applied at all four wheels during a stop, the rear wheels would lock up before the front wheels. The proportioning valve only lets a certain portion of the pressure through to the rear wheels so that the front wheels apply more braking force [8].

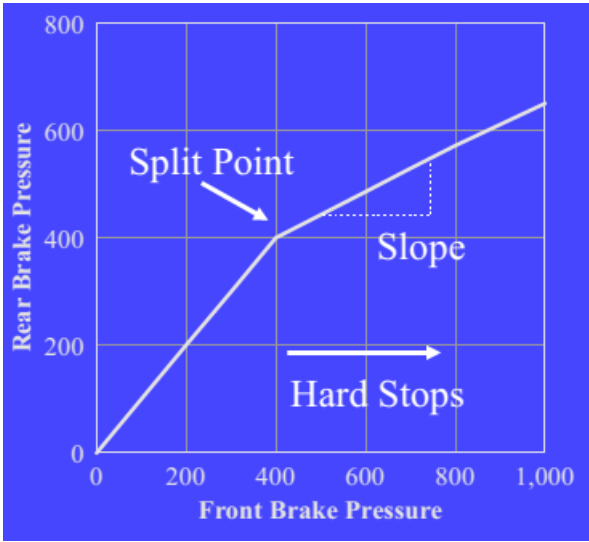

Figure 3.17: pressure distribution between rear and front wheel by Proportioning Valve [6]

Today most ABS equipped vehicles provide for the proportioning function by using the computer and electronically controlled valves in the ABS units. This is called *EVBP* (Electronic Variable Brake Proportioning) [6].

3.4.6 Front Disc Brakes

Most modern cars have disc brakes on the front wheels, and some have disc brakes on all four wheels. This is the part of the brake system that does the actual work of stopping the car. The most common type of disc brake on modern cars is the single-piston floating caliper [6].



Figure 3.18: The Disc Brake Type [6]

The disk brake is the best brake that have found in this century. Disk brakes are used to stop everything from cars to locomotives and jumbo jets. Disk brakes wear longer, are less affected by water, are self adjusting, self cleaning, less prone to grabbing or pulling and stop better than any other system around. Most of the energy that is converted into heat goes into the rotor [6].

One of the key factors in selecting the correct size brake system for a given application is to balance the thermal mass and surface area of the rotors with the amount of energy that they are going to have to handle [6].

Increasing thermal mass, by making the rotor thicker and/or larger in diameter, will reduce the temperature rise that results from a given energy input [6].

The main components of a disc brake are: -

- The brake pads.
- The caliper, which contains a piston.
- The rotor, which is mounted to the hub.

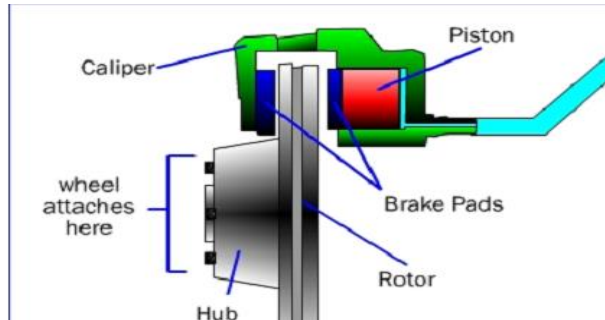

Figure 3.19: The Disc Brake Component's [6]

-The Brake Pads

There are two brake pads on each caliper. Refer to figure (3.21) :

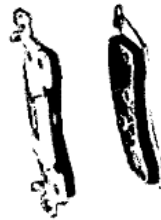

Figure 3.20: The Disc Brake Pads [7]

They are constructed of a metal "shoe" with the lining riveted or bonded to it. The pads are mounted in the caliper, one on each side of the rotor. Brake linings used to be made primarily of asbestos because of its heat absorbing properties and quiet operation; however, due to health risks, asbestos has been outlawed, so new materials are now being used [7].

The brake pads have the responsibility of squeezing on the rotor (a big steel disc which is mechanically attached to the road wheel) with the clamping force generated by the caliper. By knowing the clamp load generated by the caliper and

the coefficient of friction between the pad and rotor, one can calculate the force acting upon the rotor [7].

The rotor output force can be calculated by equation [7]:

$$Fr = F \mu 2$$

where Fr = Rotor output force (Nm)

F = Clamp force (N)

μ = coefficient of friction

- The Rotor

The disk rotor is made of iron with highly machined surfaces where the brake pads contact it. Unlike the other braking system components, the rotor serves two purposes. In order of appearance [7], they are:

- The rotor acts as the frictional interface for the brake pads. But because it is a spinning object, it reacts to the output force by absorbing the torque created (any time a force is applied to a spinning object, a torque is generated)[7]. See

Equation :-

$$\tau = Fr$$

Where τ = Torque (Nm)

F = clamp force (Nm)

r = radius (m)

- The rotor must also absorb the heat generated by the rubbing of the brake pads against the rotor face. That is because the rotor consists of vanes between the two sides of the disc that pump air through the disc to provide cooling[7].

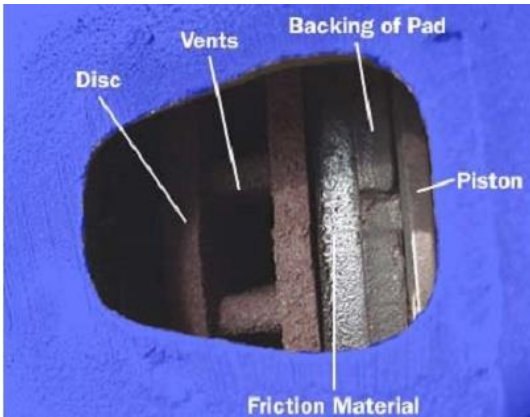

Figure 3.21: The Disc Brake Rotor [6]

- The Caliper

The caliper is the casting that is mounted over the rotor from the figure 3.23:

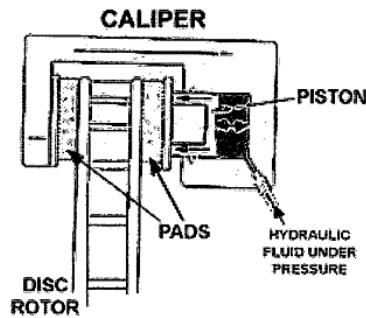

Figure 3.22: the Disc brake caliper [7]

It contains the brake pads and the hydraulic pistons that apply the pads. It must be strong enough to transmit the high clamping forces needed and also transmit the braking torque from the pads to the steering knuckle. The pressure between brake pads and each side of the rotor should be equal to prevent flexing and bind at the wheel bearings and flexing or distortion of the rotor or caliper [7].

Like the master cylinder, the caliper is just a piston within a bore with pressurized fluid on one side. While the master cylinder used mechanical force on the input side to create hydraulic force on the output side, the caliper does the opposite by using hydraulic force on the input side to create mechanical force on the output side [7].

In order to calculate the amount of clamping force generated in the caliper, the incoming pressure is multiplied by the area of the caliper piston. See Equation [7]:-

$$F = P A$$

where P = pressure generated at the master cylinder (Nm²)

A = Effective area of the caliper (m²)

The 'effective area' of the caliper will be equal to two times the area of a single 1.5" piston. See equation [7]:-

$$A = \frac{\pi d^2}{4}$$

Where d= diameter of caliper (m).

3.4.6 The Rear Drum Brakes

The drum brake may look complicated, and it can be pretty intimidating when you open one up

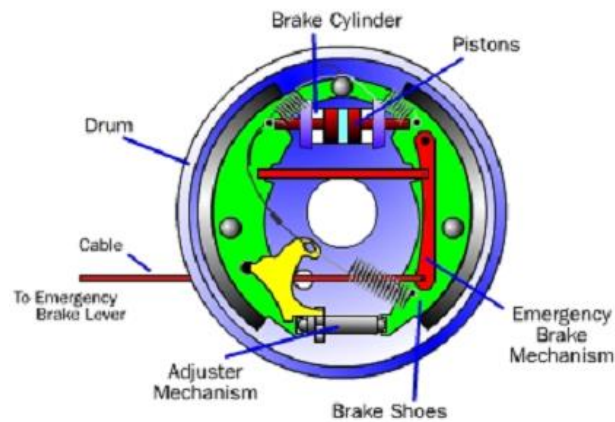

Figure 3.23: The drum brake type [6]

Like the disc brake, the drum brake has two brake shoes and a piston. But the drum brake also has an adjuster mechanism, an emergency hand brake mechanism and lots of springs [6].

When you hit the brake pedal, the piston pushes the brake shoes against the drum [6].

The extra braking force provided by the wedging action allows drum brakes to use a smaller piston than disc brakes. But, because of the wedging action, the shoes must be pulled away from the drum when the brakes are released. This is the reason for some of the springs. Other springs help hold the brake shoes in place and return the adjuster arm after it actuates [6].

The major differences have to do with the governing equation for calculating the amount of torque generated by a given amount of pressure. In drum brakes you cannot use; $2 \times \text{the lining } \mu \times \text{the piston area} \times \text{the effective radius}$. You must substitute a number called the “brake factor” The “brake factor” replaces “ $2 \times \mu$ ” [6].

3.4.7 The Emergency Hand Brake

The emergency hand brake on a car has to be actuated by a different power source than the primary braking system. The drum brake design allows for a simple cable actuation mechanism [6].

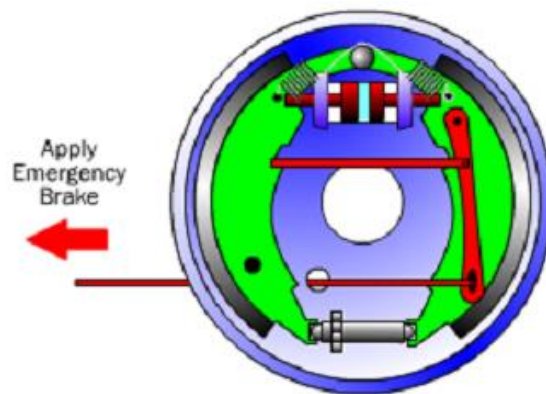

Figure 3.24: The hand brake of the drum [6]

When the emergency brake is actuated, a cable pulls on the lever, which forces the two shoes apart. The most common service required for drum brakes is changing the brake shoes see the figure (3.25):



Figure 3.25: The drum brake pads [6]

Some drum brakes provide an inspection hole on the back side, where you can see how much material is left on the shoe. Brake shoes should be replaced when the friction material has worn down to within 0.8 mm of the rivets. If the friction material is bonded to the backing plate (no rivets), then the shoes should be replaced when they have only 1.6 mm of material left [6].

Disc brakes have a minimum allowable thickness, drum brakes have a maximum allowable diameter. Since the contact surface is the inside of the drum, as you remove material from the drum brake the diameter [6]



Figure 3.26: The drum brake rotor [6]

3.3.8 The Wheels and Tires

It is the interface between the tire and the road that reacts to this torque, generating a force between the tire and the road that will oppose the motion of the vehicle [7]. See equation :-

$$F = \frac{\tau}{r}$$

Where F = Force generated between tire and road (N)

τ = Torque (Nm)

r = Rolling radius (m)

CHAPTER FOUR

THE SYSTEM DESIGN

4-1 Introduction

In fact if human is braking the car the driver take time to make the decision of braking and also in high emergence braking it take a time in the pushing the brake pedal to it is maximum position, sometimes these delay times make a difference between cases of high level accident or low level or not happening ,one the advantage of these system is minimize these two factors by high amount.

And in some cases of non-careful human driving these system useful, The car takes a distance to brake, this distance is varies depends on many factors (car's speed , the pressure force on the pedal) . In this project this factors involved in a control system which could handle with the brake automatically .The system has been designed for an emergency situations in the speeds range (20 - 60)Km/h, so it apply the full braking only which is specified by the distance between the car and anything in front the car. This distance has been detected by Ultrasonic sensor's which has been put in a car front, the controller has been programmed with a specific data stored in a fuzzy functions The system will take the decision at that moment which at the distance start to be small amount lower than the safety value (which specified in the fuzzy membership's) which has been specified .Then the controller will energize the solenoid coil which is pushing the braking actuator with it is maximum. So the braking accurate

4.2 The Hardware Design

There are five basic items that determine the strength of a magnetic field of coil in an electro magnet:

- The number of turns in the solenoid's coil.
- The current in the coil.
- The reluctance of the flux path.
- The air gab length.
- The air gab section area.

In this design, several important factors are considered: the small size, the required mechanical force and the operating distance (the displacement required by the solenoid column).

Analytical design :

To enable power in Solenoid design, the following equation was used:

$$F = (\mu_0 * n^2 * A_g * i^2) / (2 * l_g^2) \quad (5.1) \quad [9]$$

n = Number of rolls in the Coil = 290 turn

i = coil current = 20 Amp

μ_0 = the air gab permeability = $4\pi * 10^{-7}$

A_g = Area of the air gap (m) = $\pi (0.025)^2$ m

l_g = Length of the air gap (m) = 0.015 m

F = the solenoid force (N)

4.2.1 Place of Solenoid Actuator

The force which required from Solenoid depends directly on where the Solenoid will installed to Pulled by brake pedal. It was found that the place that provides a small solenoid size .Is in the horizontal rod which connects the brake pedal with the master cylinder of figure (4.1).

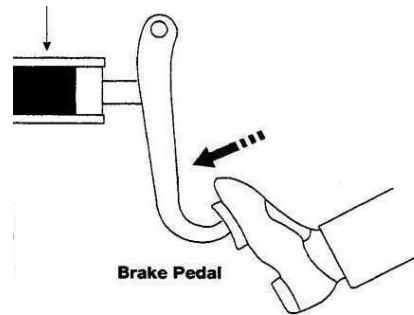

Figure 4.1: The solenoid actuator installation place

In this position a large force required from solenoid, but in other hand it also requires minimum displacement from the solenoid.

This position minimize the solenoid's size, because the effect of decreasing the displacement is greater than the effect of the increase in the required force, which minimize the number coil's turns. Which means a small volume of the solenoid.

4.2.2 Calculate the power required from the Solenoid

The maximum force of the driver's foot of brake pedal in an automatic cars is located in the range (60 - 80) N. The foot's force value which taken in the design is 84 N .And the force which required by the Solenoid was calculated by using the leverage principal.

$$\text{The solenoid force} = (32.5 *84)/12.5 = 238.26 \text{ N} \quad (4.2)$$

The measurements was taken from the corolla model 2016.

4.2.3 Displacement And Strength Of The Brake Pedal

The function between the displacement of the brake pedal and its pushing force it could be classified as linear . when you press more in brake pedal it will move more inside. see figure (4.3) .

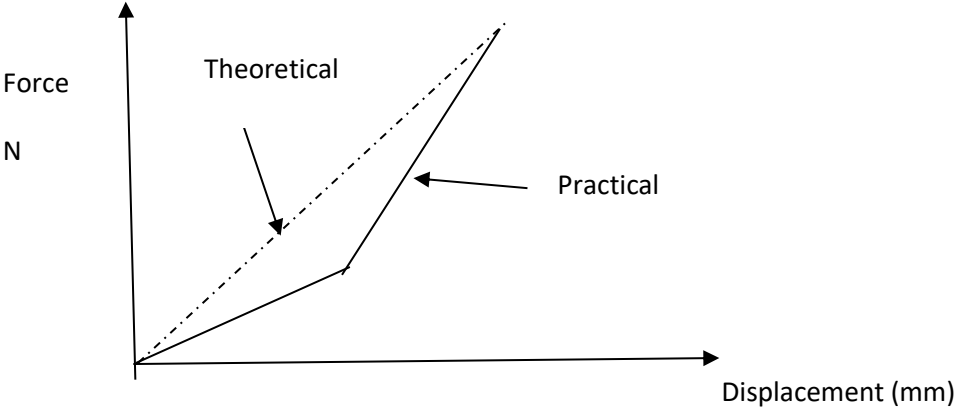

Figure 4.3: The brake pedal curve

In this project the work will be on the theoretical curve as the process of measuring the force of each displacement in practice. Taking the last point or point of maximum force and displacement of the pedal .

After taking a required measurements of Corolla 2016 TOYOTA car ,The brake pedal displacement was found about 0.016 mm ,for safety from the brake units damage while the solenoid’s actuating it is displacement is kept 15 mm.

$$Gad = 16 - \text{displacement (mm)} \tag{4.3}$$

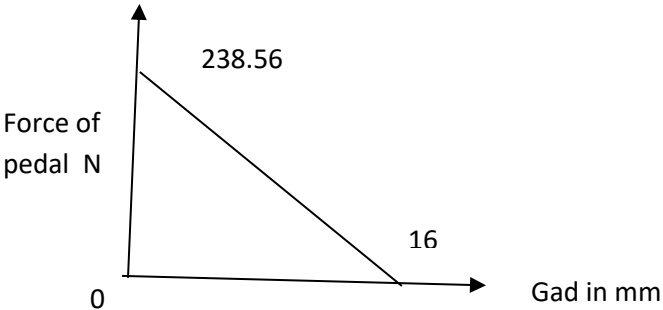

Figure 4.2 : The Theoretical Brake Pedal Force Curve

The lines points : (0,238.56) => (16,0)

$$F = (- 238.56 * x)/16 + 238.56 \quad (4.4)$$

4.2.4 Coil Design

Since the resultant force of the Solenoid is varying during its movement (that because the length of the air gap changes during its movement). As a begin the point of the middle of the solenoid air gap it was taken (because it give a near touch of required specification's):

$$Gad_{pedal} = 0.0085 \text{ m} , Gad_{solenoid} = 0.0075 \text{ m} , F_{pedal} = 111.825 \text{ N}$$

$$F_{design} = F_{pedal} + 25\% F_{pedal} = 139.78125 \text{ N} \quad (4.5)$$

$$139.78125 = ((N)^2(20)^2x \pi x 10^{-7} x \pi(0.025)^2)/(2 x (0.0075)^2)$$

$$N = 252.45 , \quad N = 253 \text{ turn}$$

- The coil's plastic chair length equals 4.6 cm
- The used wire diameter is "0.213 cm"

$$\text{So that layer turns} \Rightarrow N = 4.6 / 0.213 = 21.6$$

Thus the layer contains 21 rolls

The number of required layers equals 13 layer

Assume that the wire is as in shape:

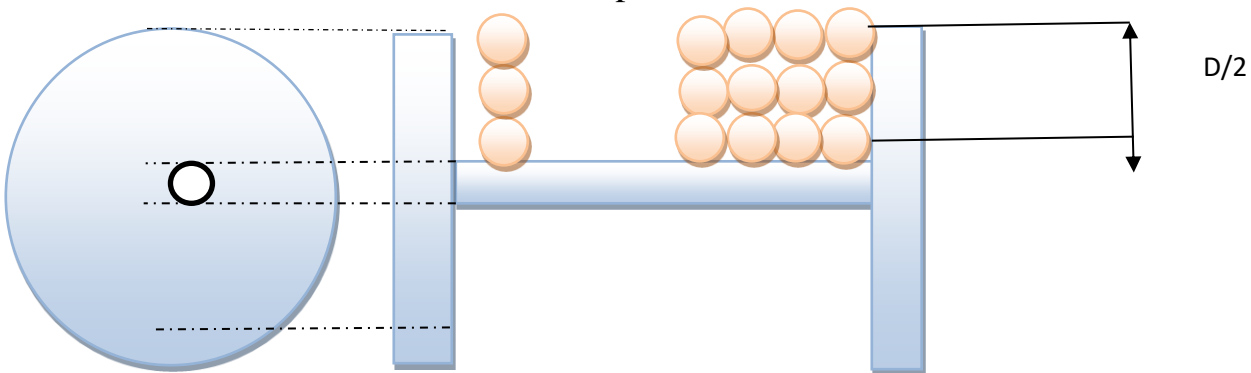

Figure 4.4: The wire's housing each other

Diameter coil => $D = 0.213 * 13 * 2 = 5.538 \text{ cm}$

To calculate wire length, the wire length for every turn determined by circumference of a circle rule and add every layer length and added :

$$L = \sum_{n=1}^{12} [21 * 2 * \pi (2.5/2 + 0.075 + 0.213(n-1) + 0.213/2) + 2 * \pi * (2.5/2 + 0.075 + 0.213 (13-1) + 0.213/2)] \quad (4.6)$$

$$L = 4146.5473 \text{ cm}$$

The design's wire length was expected about 5183.18741 cm

$$\text{Expected coil resistance : } R = 52.09 * 10^{-6} * 4146.5473 = 0.216 \Omega \quad (4.7)$$

$$\text{Expected coil's weight : } W = 0.2977 * 4146.5473 = 1234.43 \text{ gm} \quad (4.8)$$

But in fact the wire's houses each other when like figure (4.5) :

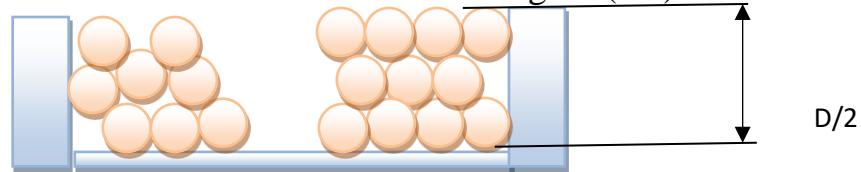

Figure 4.5 : The actual housing of wire's

$$\text{It becomes the coil's diameter : } D = 0.213 * 13 * 2 * 0.91 \quad (4.9)$$

$$\Leftrightarrow D = 5.03958 \text{ cm}$$

Length of the wire

$$L = \sum_{n=1}^{12} [21 * 2 * \pi (2.5/2 + 0.075 + 0.213(n-1) * 0.91 + 0.213/2)]$$

$$+ 2\pi * (2.5/2 + 0.075 + 0.213 * 12 * 0.91 + 0.213/2) = 3978.16 \text{ cm} \quad (4.10)$$

$$\text{Length of required wire of design work is } 4972.7 \text{ cm} \quad (4.11)$$

The expected Coil weight & resistance

$$R = 3978.16 * 52.09 * 10^{-6} = 0.2072 \Omega \quad (4.12)$$

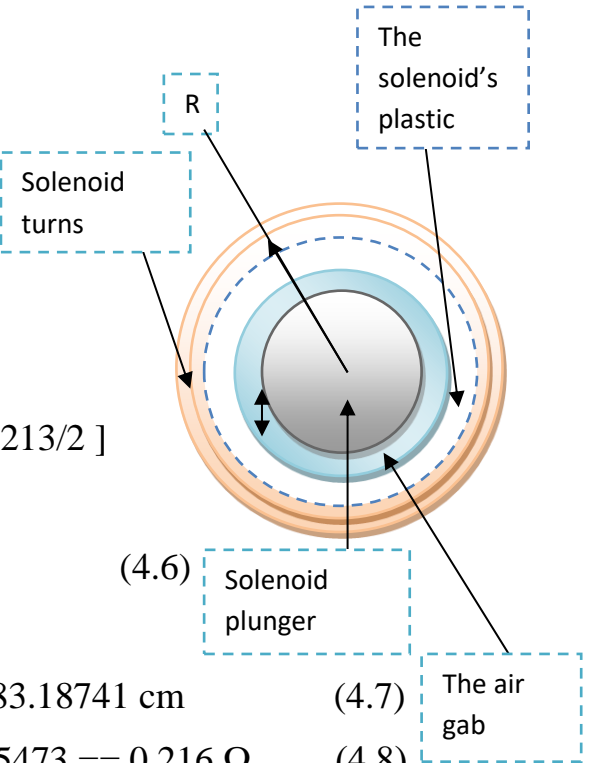

$$W = 3978.16 * 0.2477 = 985.39 \text{ gm} \quad (4.13)$$

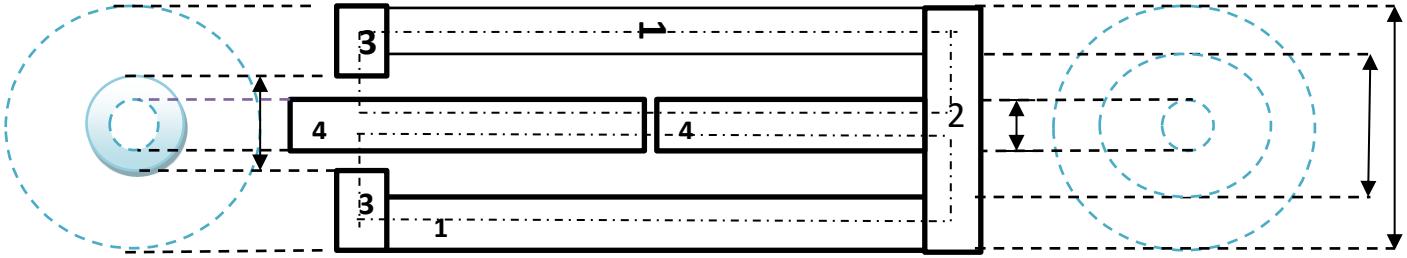

Figure 4.6 : The magnetic field in the solenoid core

In cylindrical parts 3&2 the sectional area which flux crossed is varying so it is average value of the inner surface and outer surface area which taken .

$$L_1 = 0.05 \text{ m} , A_1 = \pi/4 * (8.29^2 - 7.69^2) , A_1 = 0.0015 \text{ m}^2 \quad (4.14)$$

$$L_2 = 0.03845 \text{ m} , A_2 = (A_A + A_B) / 2 \quad (4.15)$$

$$A_A = 2 \pi * 2.5/2 * 0.3 = 2.3562 \text{ cm}^2 \quad (4.16)$$

$$A_B = 2 \pi * 8.29/2 * 0.3 = 7.81314 \text{ cm}^2 \quad (4.17)$$

$$A_2 = 0.0004909 \text{ m}^2 \quad (4.18)$$

$$L_3 = 0.0287 \text{ m} , A_3 = (A_D + A_C) / 2 \quad (4.19)$$

$$A_D = \pi * 2.55 * 0.3 = 0.000243 \text{ m}^2 \quad (4.20)$$

$$A_C = \pi * 2.5 * 0.3 = 0.0002356 \text{ m}^2 \quad (4.21)$$

$$A_3 = 0.0002393 \text{ m}^2 \quad (4.22)$$

$$L_4 = 0.05 \text{ m} , A_4 = (\pi * (2.5)^2 * 0.0004909) / 4 \text{ m}^2 \quad (4.23)$$

$$L_{PW} = 0.00025 \text{ m} , A_{PW} = 2\pi * 2.55 * 0.3/2 = 0.0002463 \text{ m}^2 \quad (4.24)$$

$$A_g = \pi (2.5)^2 / 4 = 0.000491 \text{ m}^2 \quad (4.25)$$

$$L_4 = 0.05 \text{ m} , A_4 = 0.000491 \text{ m}^2 \quad (4.26)$$

When Takes into account the magnetic reluctance of the solenoid's material

$$F = \mu_o * N^2 * (I_i)^2 * A_g / 2(L_g + L')^2 \quad (4.27) \quad [9]$$

$$L' = L_1 * A_g / (\mu_r * A_1) + L_2 * A_g / (\mu_r * A_2) + L_3 * A_g / (\mu_r * A_3) + L_{pw} * A_g / A_{pw} + L_4 * A_g / (\mu_r * A_4) \quad (4.28) \quad [9]$$

$\mu_r = 902.6$ (The relative permeability of the core material)

$L' = 0.00049283 \text{ m}$

Force of 10 mm air gab is 71.724 N

Let $N = 260 = F_{\text{solenoid}} = 75.748 \text{ N}$

$L = 4143.42 \text{ Cm}$, $R = 0.2158 \Omega$

4.2.5 The Core Material

The solenoid is wearied by metallic core which surround it, it is an importance part to void the coil's magnetic field dissipation (and minimized for lowest limits (can ignored) by choosing a material has a high relative permeability factor and also increase the core thickness).The choose will be the AISI 1010 carbon steel, because it has a good thermal properties and high relative permeability and it is good mechanical properties.

The need for good thermal properties is to minimize the coil's temperate increasing (their is temperate generation from the solenoid while it operates).

The mechanical properties to meet the mechanical force needs .

The design structure with dimension's shown in figure (4.7)

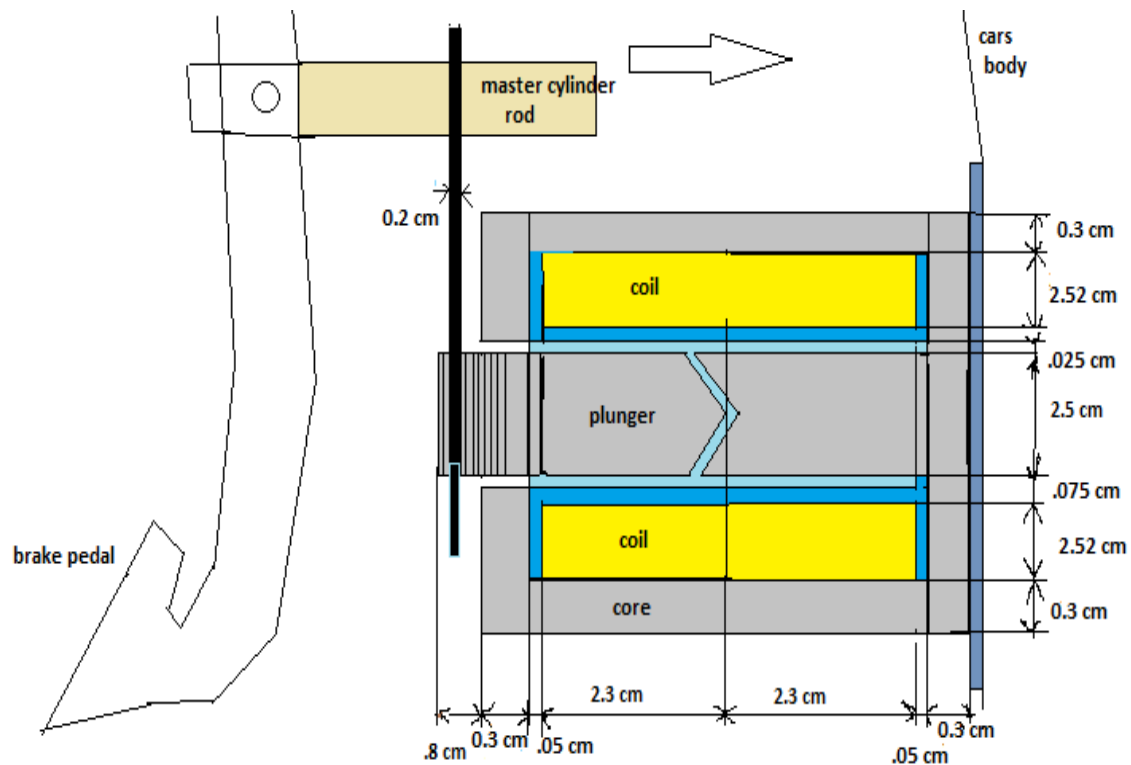

Figure 4.7 : The actuator structure design

4.3 The Sensor's Positions

The sensors which used for the distance detection is placed in the front part of the car ,It is care for that the sensor beam is which about 30 cm [12], And the high from the ground. like figure (4.8):

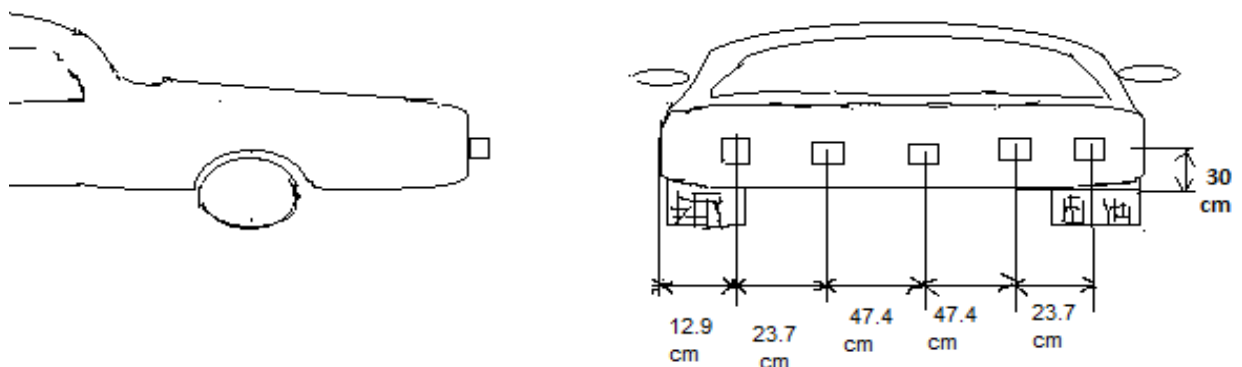

Figure 4.8 : The sensor places on the car

These sensors distribution for corolla 2016 car .

4.4 The Software Design

Using fuzzy control is the best choice because the desire stopping distance is almost estimated and it's calculating is very difficult for every situation.

The system take distance reads and after specified period it will take another distance read and calculate the speed from this two distance reads & period between the two reads of distance.

In situation of fixed target's the speed which calculated by the system will be the car's speed and at the movable target's cases the system speed which calculate will be the difference in speeds of the target and car after that the system will compare the speed's stopping distance of fuzzy system and the last read of distance from two reads, if the fuzzy system distance plus safety zone is greater than last distance read the system will not operates the brakes otherwise the system will operate it.

The system will operates a buzzer (to careful the driver) before operating the brakes if the driver doesn't brake the car the system will operate the brakes.

In the software the fuzzy system memberships built of experimental result which is taken from other study which in table 4.1:

No.	Vehicle speed, km/hr	Vehicle speed, m/s	Experimental stopping distance (SD), m		Theoretical stopping distance (SD), m	
			ABS	Non-ABS	ABS	Non-ABS
1	40	11.00	2.9	5	2.7	3.4
2	50	14.50	4	7	4.2	5.4
3	60	17.00	6.5	9.3	5.9	7.7

Table 4.1 : Experimental and simulated values of the stopping distance [11]

The ABS result which was taken because the control system specified only for automatic cars which was already included by ABS. for cars of 2010 to 2016 car's models.

The figure (4.9) shows the system's fuzzy membership

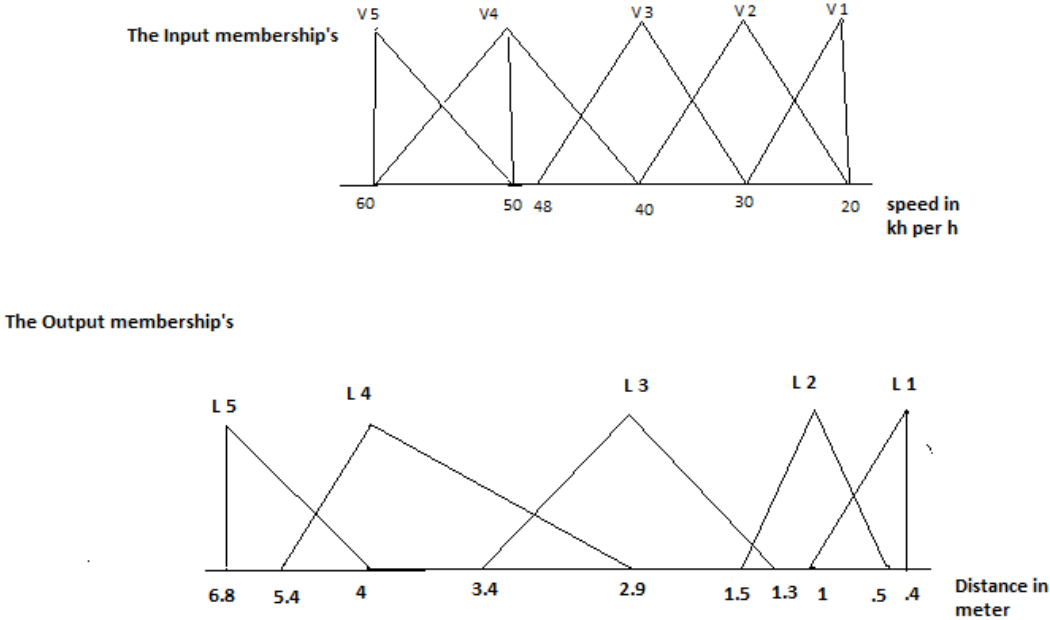

Figure 4.9: The Fuzzy Membership's function.

The system work shown in the flow chart :

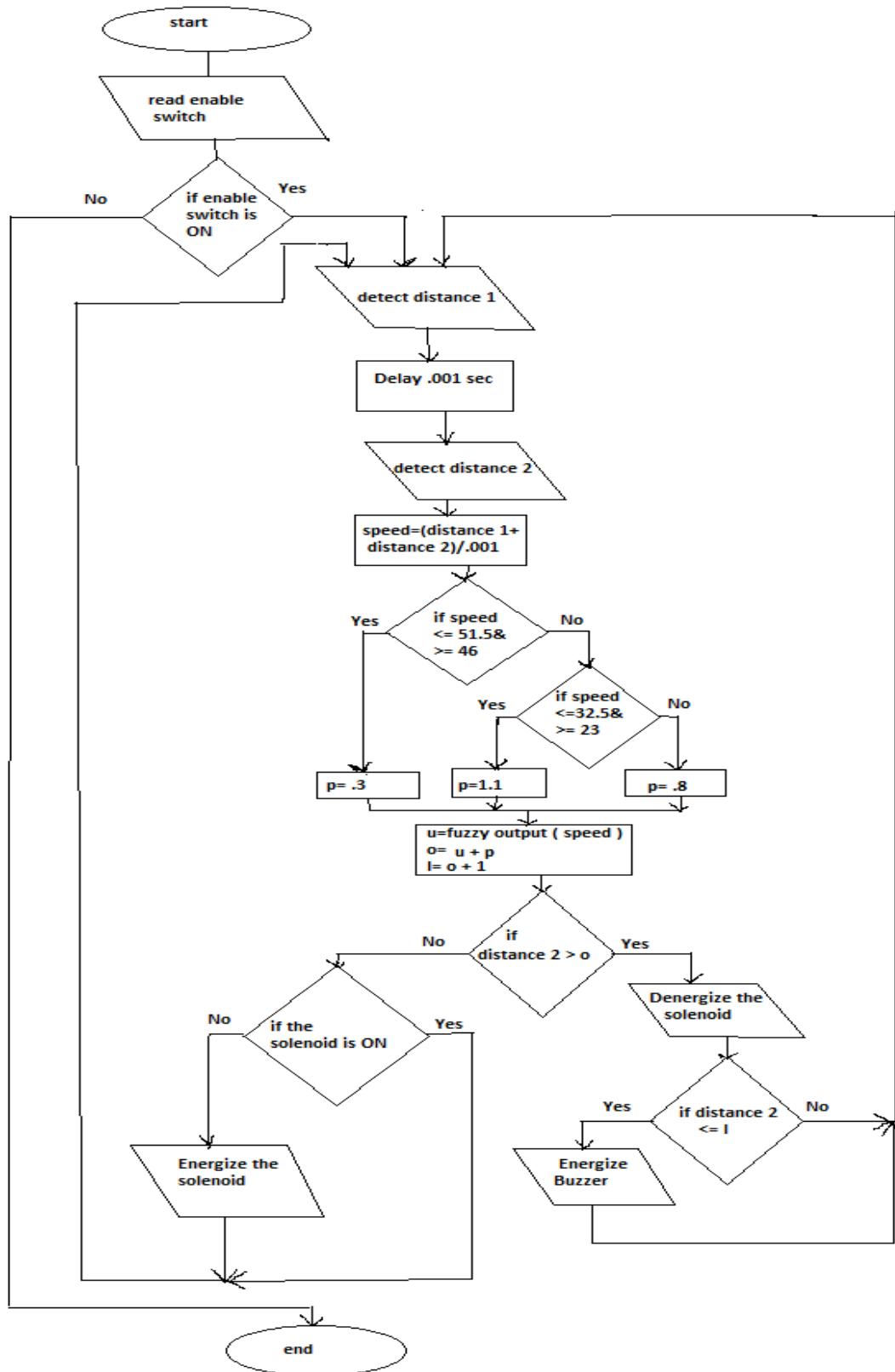

Figure 4.10 : Flow chart

4.5 The System Block Diagram

The figure (4.11) :

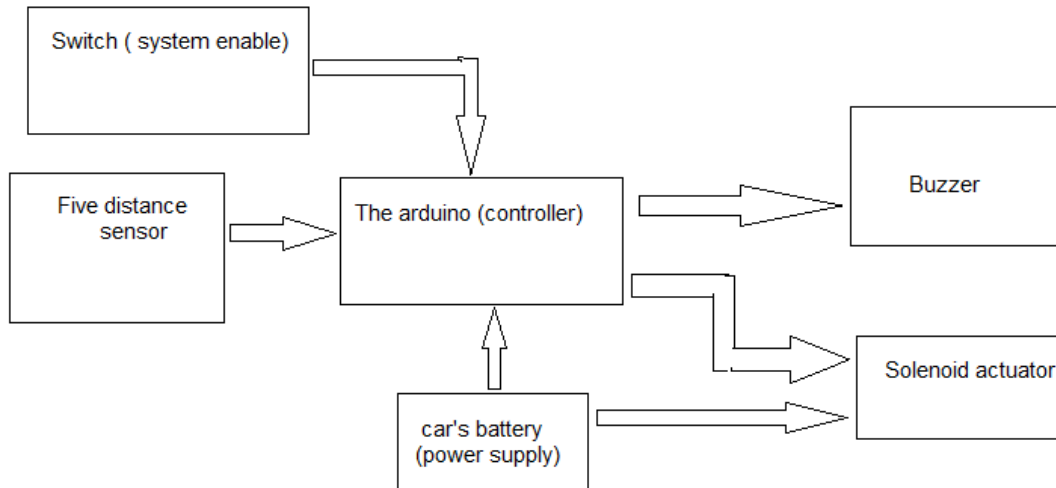

Figure 4.11: System block diagram

Shows the structure of the brake pedal control system which is had five distance sensors and switch for enabling all the system and the system take it supply from the car's battery and the system output's which is buzzer and solenoid actuator .

Represents the wiring circuit of control system shown in figure (4.12):

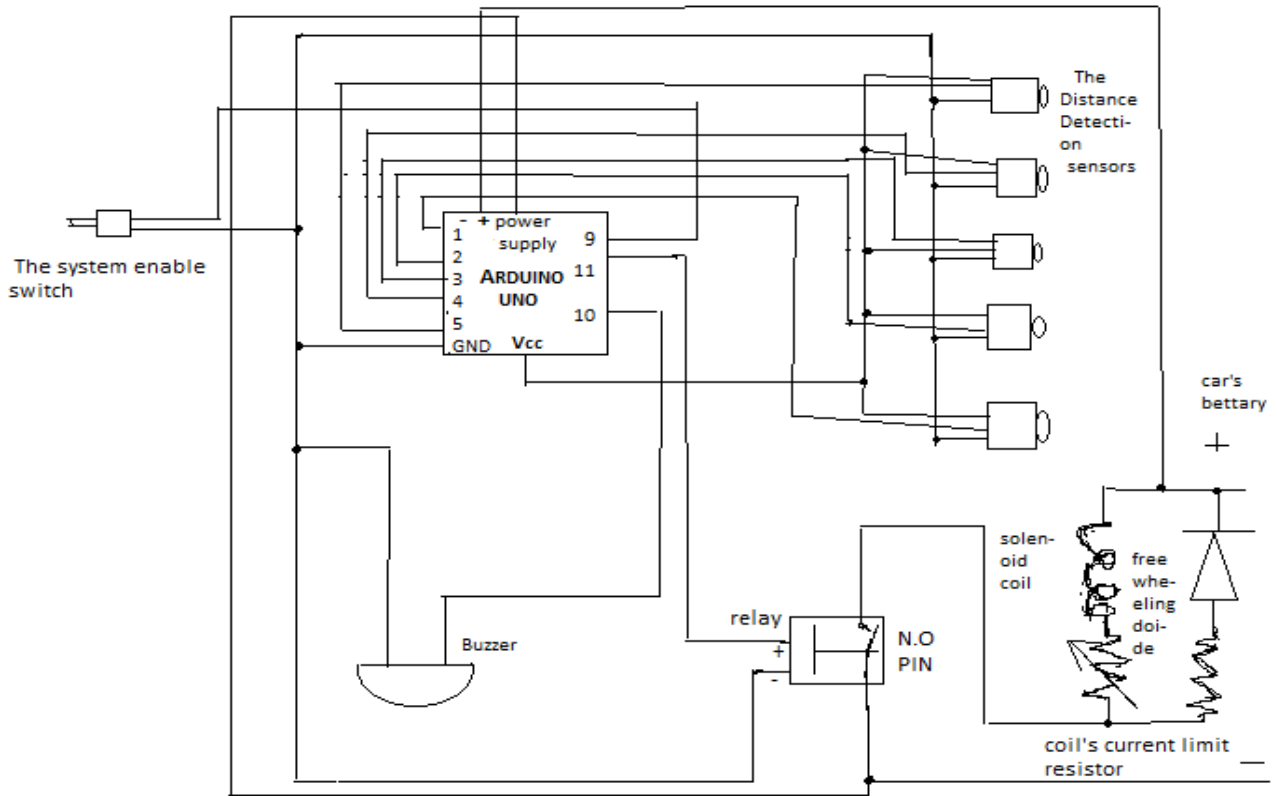

Figure 4.12: The wiring circuit

A five sensors connect to the Arduino as analog inputs and one digital output of the Arduino connected to relay(to energize the solenoid actuator) which controls the coil that when its energized will pull the brake pedal of the car and connecting the coil free-wheeling diode in parallel and both connected in series with variable resistance to adjust the current value .when the sensors gets reads send the distance analog signal to Arduino when the Arduino receive two reads from sensors and calculate the difference in speed between the car and the target and determines the appropriate distance to brake and another distance to warn the driver throw buzzer. Every sensor had Vcc supply which +5 volt ,GND, Analog output .

4.6 THE SOFTWARE & HARDWARE DESGINS ANLAYSIS

4.6.1 The hardware analysis

In The solenoid actuator design ,by using MatLab software of plotting , if the brake pedal working curve shown in the figure (4.13):

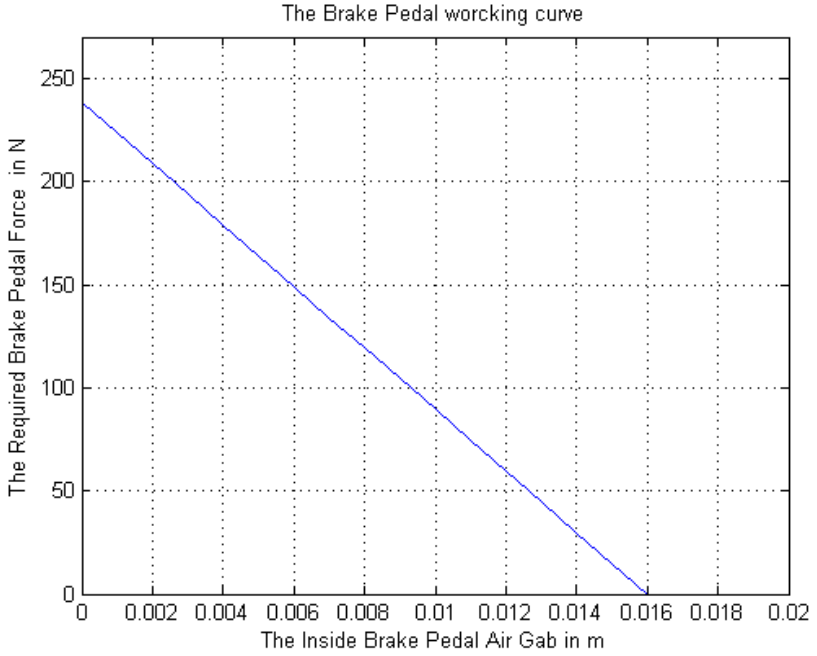

Figure 4.13: The brake pedal working curve

From the first result of the solenoid design the idea solenoid working curve (after ignore the magnetic reluctance of solenoid’s core and the sides air gab reluctance) in the figure (4.14).

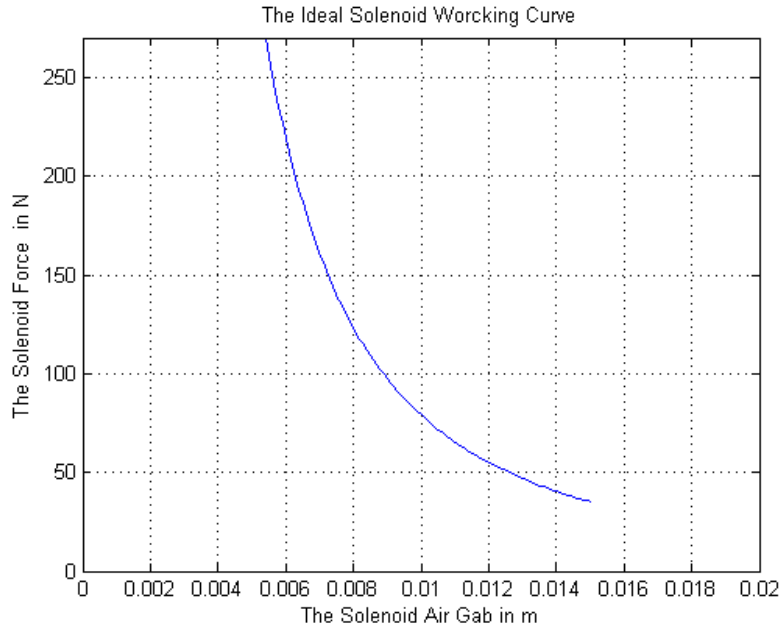

Figure 4.14: The ideal solenoid working curve

When the reluctance's of core and the air gab's is taken in account the resultant working curve will shown in figure (4.15):

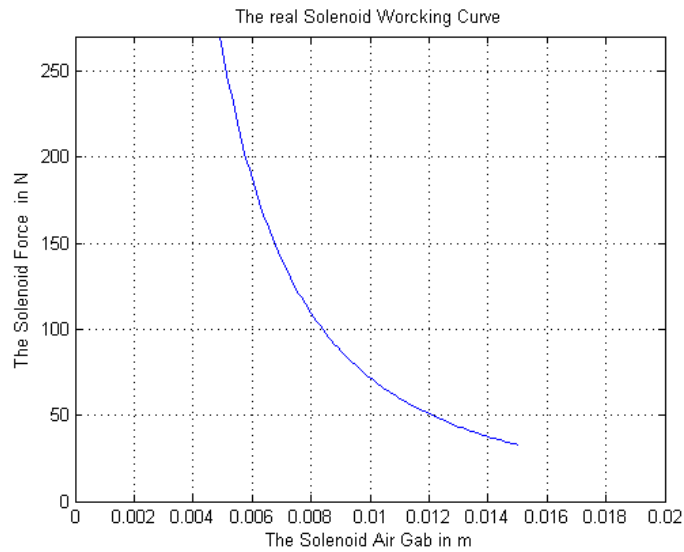

Figure 4.15: The real working curve of the solenoid

The solenoid working curve must be over the pedal curve if not the process of brake pedal actuating will field. so the brake pedal will stop at that point that the two curve will cross each other , the compares the two curves shown in figure (4.16) :

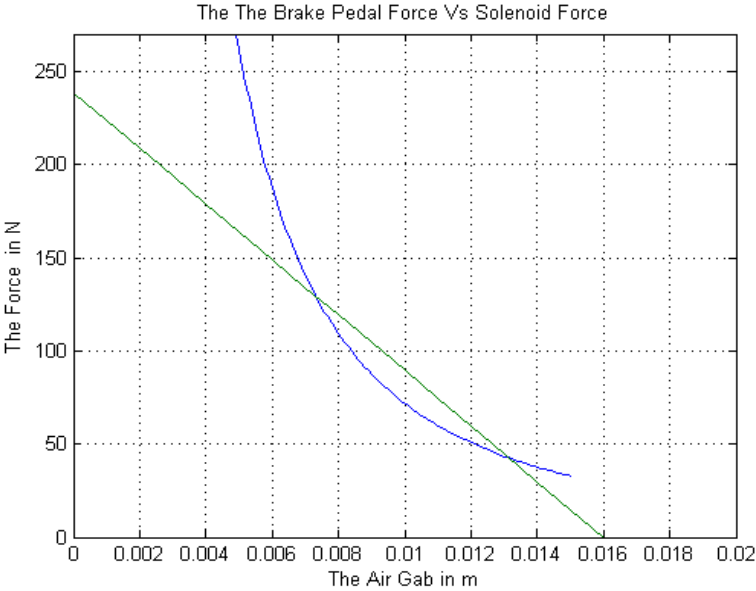

Figure 4.16: The Brake Pedal Working Curve Vs. The Solenoid Curve

It is clear that their some point of the solenoid curve under pedal curve .so it is required to solve this problem by increasing the solenoid turns number to (290 turn s) to give the resultant curve in the figure (4.17).

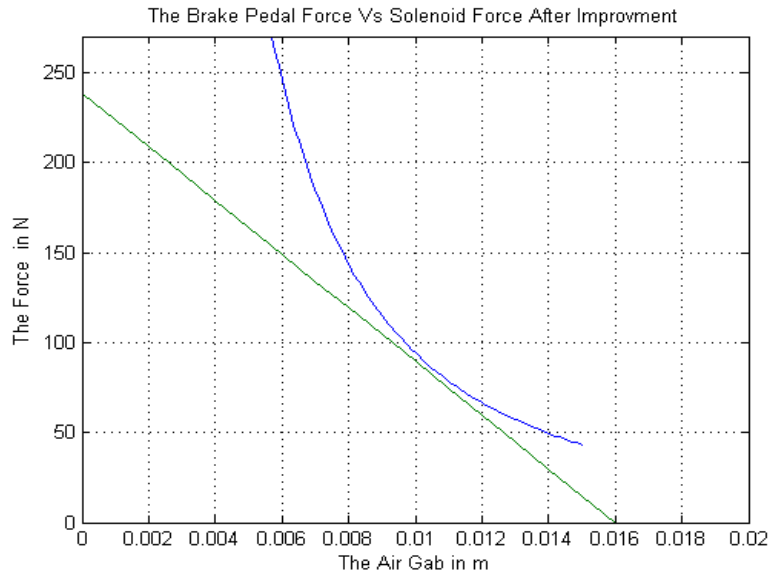

Figure 4.17: The pedal and solenoid working curve after the improvement

It clear that the solenoid's working curve is modified to meeting the brake pedal actuating process. And also needs to add another layer which changed the actuator dimension's is shown in the figure (4.18):

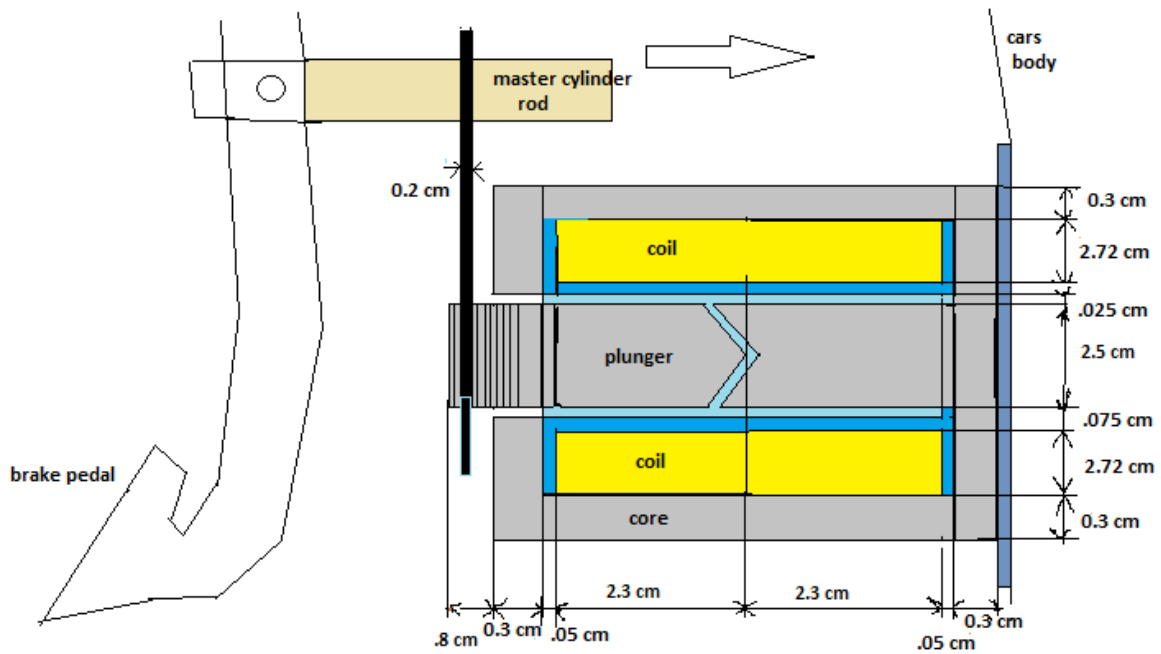

Figure 4.18: The final actuator structure after correction

And the expected length of wire will be (4982.66 cm) .And it's resistance is (0.26 ohm).

4.6.2 The Software Result Analysis

In the software the fuzzy system's membership function's will gives the result curve in the figure (4.19)

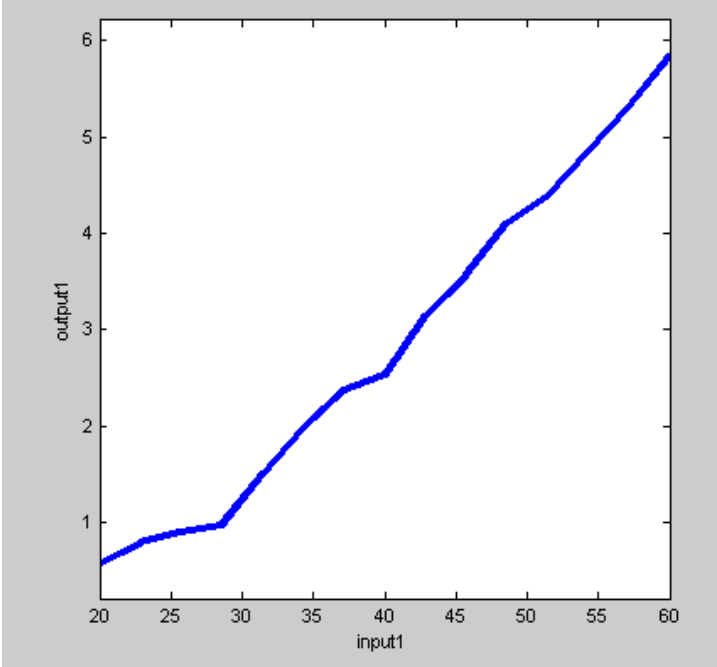

Figure 4.19: The Result Of The fuzzy System Simulation

The input is speed of the car in kilometer per hour and the output is necessary braking distance in meter .it was taken from the experimental result's in the curve of the figure (4.20):

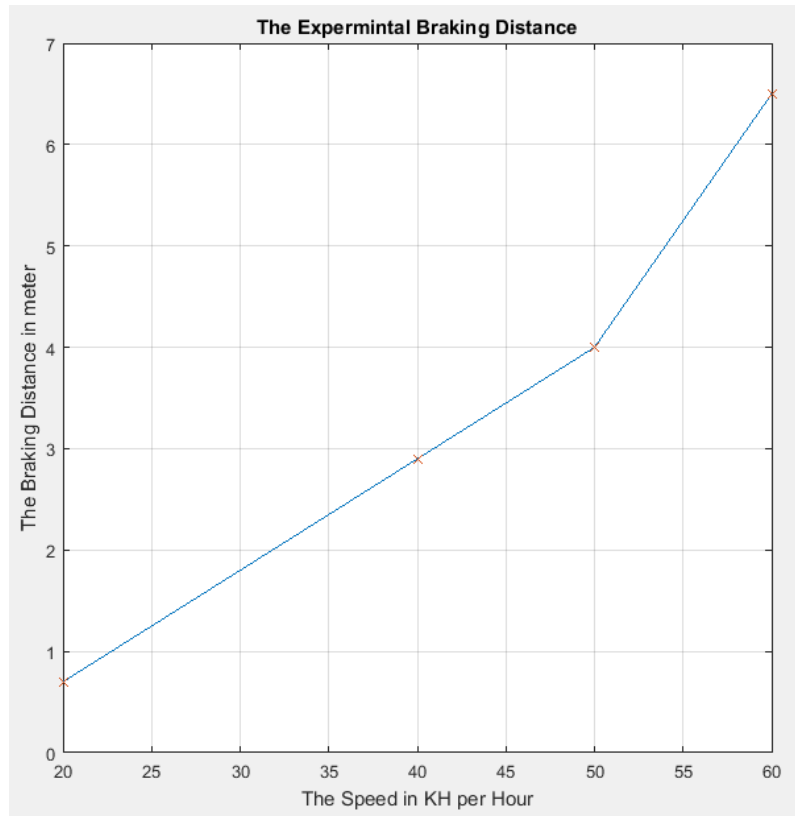

Figure 4.20: The braking distance experimental result

If it compared between the two curve to see if the fuzzy system meet our requirements in figure (4.21):

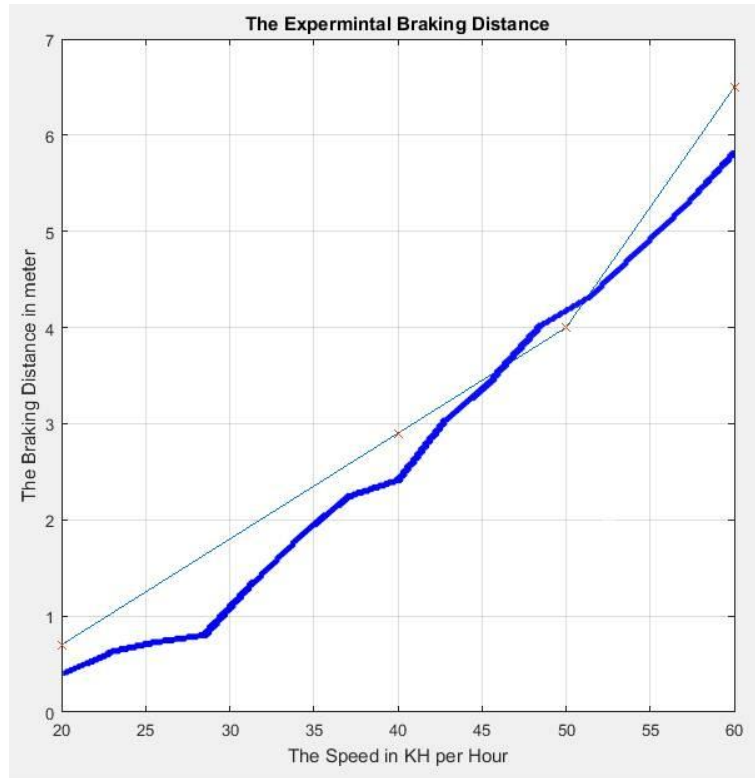

Figure 4.21: Fuzzy system output Vs. experimental Results

It was clear the different between the two curve's this problem is solved by making the final output of the system is the fuzzy system output plus correction value specified for every speed ranges.

CHAPTER FIVE

CONCLUSION AND RECOMMENDATIONS

5.1 Conclusion

By using MATLAB plotting in the designing and fuzzy membership function's

The brake system is relatively complex and difficult to attach an element to the brake system without effecting the system operation, but this system is separated and doesn't effect at brake system work.

The system was made to limits the traffic accidents and make the car driving more safety.

The system size is small and it had low cost.

5.2 Future work

For making this system more efficiently it could be combined with other steering actuator and controlled for at high speeds emergency situations.

Also for making this system more perfect is could be attach a unit to for fuel economy (at the moment at the brake actuator is operates immediately and the driver's foot still on the fuel pedal the car will brake but the engine is still burn more fuel)

And also it could be attach an electronic unit to leveling the actuator force to give activate the braking system more smoothly.

Also it could using the model predictive control technology to control the braking and steering decisions than fuzzy control to make the system more reliable and more efficiently .

REFERENCES

- 1- Sandeep Thorat Sanket Thorve, Jaydatta Upase and Agampal Singh Dhupar, “Design and Implementation of Automatic Emergency Braking System ”, proceeding of Mechanical engineers, International Journal for implementing control system for cars an emergency braking , 2016, Special Issue 4, E-ISSN 2277 – 4106, P-ISSN 2347 – 5161.
- 2- Sushil kumar and Vishal Kumar. “ AUTOMATIC EMERGENCY BRAKING SYSTEM ”, proceeding of Mechanical & Electronics and Communication engineers, International Journal of design control system for automatic safety braking of cars , Volume 1 , Issue 3, pages 93-96 , 2015 , E -ISSN 2394-8299 , P-ISSN 2394-8280.
- 3- Mechanical Actuation and Low Level Control for a BMW X5 Automatic Safety System Research , 6th , June 2011, pp 2053-0995 .
- 4- Braking systems ,19th , April ,
hs-karlsruhe.de
- 5- AUTOMOBILE BRAKE SYSTEM ,19th , April, 2017 ,
ernet.in
- 6- AUTOMOBILE BRAKE SYSTEM ,19th , April, 2017 ,
atbnsw.com.au
- 7- DEVELOPMENT OF BRAKE SYSTEM MODEL FOR EDUCATIONAL PURPOSE Research , June 2009 , pp 037945-1060 .
- 8- Car brake systems , 19th ,April ,2017,
sae.org

- 9- George P. Gogue & Joseph J . Stupak, Jr. “ Theory & Practice of Electromagnetic Design of DC Motors & Actuators ” , G2 Consulting, Beaverton, OR 97007 .
- 10- Electromagnetic Linear Actuator -Design, Manufacture and Control Research ,October 2009, pp 4111-4112 .
- 11- Mohamed Watany et al. Performance of a Road Vehicle with Hydraulic Brake Systems Using Slip Control Strategy. American Journal of Vehicle Design, 2014, Vol. 2, No. 1, 7-18. doi:10.12691/ajvd-2-1-2 .
- 12- MaxSonar EZ1 ultrasonic sensor Datasheet , 9th , October , 2017,
https://www.maxbotix.com/documents/LV-MaxSonar-EZ_Datasheet.pdf
- 13- The AISI 1010 material properties ,28th , July, 2017,
<http://www.azom.com/article.aspx?ArticleID=6539>
- 14- High flux enameled wire , 20th , July , 2017 ,
www.changsung.com

APPENDIX A

Wire Data Sheet & Controller Data sheet

Wire data sheet :

Specifications of the wire used [14]:

Raising at $20\text{ }^{\circ}\text{C} = 52.09 = 10^{-6}\Omega.\text{cm}$

$D = 0.213\text{ cm}$

$A = 33.08 * 10^{-3}\text{ cm}^2$

Weight = 0.2977 gm/cm

AWG wire NO.12

Maximum Current = 26.1 Amp

Controller data sheet :

Arduino uno is a microcontroller board based on the ATmega328P .it has fourteen digital input/output pins (of which six can be used as PWM outputs), six analog inputs,a 16 MHz quartz crystal , a USB connection a power jack, an ICSP header and a reset button. It contains everything needed to support the microcontroller; simply connect it to a computer with a USB cable or power it which a AC-to-DC adapter or battery to get started.

APPENDIX B

DISTANCE SENSOR DATA SHEET

LV-MaxSonar®-EZ1™ High Performance Sonar Range Finder

With 2.5V - 5.5V power the LV-MaxSonar®EZ1™ provides very short to long-range detection and ranging, in an incredibly small package. The LV-MaxSonar®-EZ1™ detects objects from 0-inches to 254-inches (6.45-meters) and provides sonar range information from 6-inches out to 254-inches with 1-inch resolution. Objects from 0inches to 6-inches range as 6-inches. The interface output formats included are pulse width output, analog voltage output, and serial digital output[12].

Features

- Continuously variable gain for beam control and side lobe suppression
- Object detection includes zero range objects
- 2.5V to 5.5V supply with 2mA typical current draw
- Readings can occur up to every 50mS, (20-Hz rate)
- Free run operation can continually measure and output range information
- Triggered operation provides the range reading as desired
- All interfaces are active simultaneously
- Serial, 0 to Vcc, 9600Baud, 81N
- Analog, $(V_{cc}/512) / \text{inch}$ • Pulse width, (147uS/inch)
- Learns ringdown pattern when commanded to start ranging
- Designed for protected indoor environments
- Sensor operates at 42KHz
- High output square wave sensor drive (double Vcc)

Benefits

- Very low cost sonar ranger
- Reliable and stable range data
- Sensor dead zone virtually gone
- Lowest power ranger
- Quality beam characteristics Mounting holes provided on the circuit board
- Very low power ranger, excellent for multiple sensor or battery based systems
- Can be triggered externally or internally
- Sensor reports the range reading directly, frees up user processor Fast measurement cycle
- User can choose any of the three sensor outputs

The under figure show the sensor beam Characteristics:

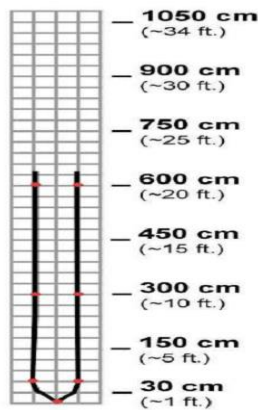

APPENDIX C

Experimental braking distance test's information's

No.	Parameter	Symbol	Value	Unit
1	Quarter vehicle mass	m	447.5	Kg
2	Acceleration due to gravity	g	9.81	m/s ²
3	Radius of wheel	r	0.308	m
4	Moment of inertia	J	1.7	Kg.m ²
5	Initial vehicle speed	V	11, 14, 17	m/s
6	Number of friction surfaces	n	2	-
7	Effective brake radius	R _d	0.112	m
8	Tyre radius	R _w	0.308	m
9	piston radius	r	0.0185	m
10	Drag coefficient	C _d	0.539	-
11	Projected Area	A _f	2.04	m ²
12	Max pressure	P	20.10 ⁶	N/m ²
13	Disk brake coefficient of friction	μ	0.35	%
14	Effective Disc Radius	R _d	0.112	m
15	Valve time delay	v _{vd}	0.1	s

Braking road tests were performed on Peugeot 406 vehicle. The condition of road surface is dry asphalt. The tests were carried out to measure the stopping braking distance (SD) when the vehicle was braked at vehicle speed of 40, 50 and 60 km/hr to reach 0.0 km/hr, the vehicle was equipped by either assisted ABS or non-ABS system [11].

- Testing Procedure

In each test, the driver took the vehicle out of gear a short time before the vehicle brakes were engaged, the driver initiated the data-logger, so that a short period of coasting could be recorded, and then the braking solenoid was activated. A dry asphalt road conditions with rolling resistance coefficient (f_r) of 0.018 Three repeat tests were completed at nominal set brake pressures of 3 bar, 5 bar, and 8 bar on each of these surfaces. It was at first desired that the tests would be conducted from an initial speed of 11 m/s (40 km/h). This was so that the vehicle brakes would dissipate approximately the same amount of energy as they would under normal operation, with all the brakes operating, when stopping from 17 m/s (60 km/hr)[11].

APPENDIX D

Core's material properties

The core material is AISI 1010 which it is relative permeability (902.6) .mechanical properties of AISI 1010 cold drawn carbon steel are tabulated below [13].

Properties	Metric	Imperial
Tensile strength	365 MPa	52900 psi
Yield strength (depending on temper)	305 MPa	44200 psi
Elastic modulus	190-210 Gpa	27557-30458 ksi
Bulk modulus (typical for steel)	140 GPa	20300 ksi
Shear modulus (typical for steel)	80.0 GPa	11600 ksi
Poisson's ratio	0.27-0.30	0.27-0.30
Elongation at break (in 50 mm)	20%	20%
Reduction of area	40%	40%
Hardness, Brinell	105	105
Hardness, Knoop (converted from Brinell hardness)	123	123
Hardness, Rockwell B (converted from Brinell hardness)	60	60
Hardness, Vickers (converted from Brinell hardness)	108	108
Machinability (based on AISI 1212 steel as 100 machinability. The machinability of group I bar, rod, and wire products can be improved by cold drawing)	55	55

Thermal Properties

The thermal properties of AISI 1010 carbon steel are tabulated below.

Properties	Metric	Imperial
Thermal expansion co-efficient (@0.000-100°C/32-212°F)	12.2 $\mu\text{m}/\text{m}^\circ\text{C}$	6.78 $\mu\text{in}/\text{in}^\circ\text{F}$

Thermal conductivity (typical for steel)

49.8 W/mK 346 BTU in/hr.ft².°F

Other Designations

Equivalent materials to AISI 1010 carbon steel are as follows.

AMS 5050

AMS 5055

AMS 7225

DIN 1.1121

AMS 5040

AMS 5042

APPENDIX E

THE RUNNING CODE OF THE SYSTEM

```
#include <EEPROM.h>
#include <FuzzyRule.h>
#include <FuzzyComposition.h>
#include <Fuzzy.h>
#include <FuzzyRuleConsequent.h>
#include <FuzzyOutput.h>
#include <FuzzyInput.h>
#include <FuzzyIO.h>
#include <FuzzySet.h>
#include <FuzzyRuleAntecedent.h>
#define brk 11
#define alarm 10
#define sen1 1
#define sen2 2
#define sen3 3
#define sen4 4
#define sen5 5
#define sw 9
// Step 1 - Instantiating an object library
Fuzzy* fuzzy = new Fuzzy();
floatspeed_period = 0.1;
// calculate speed in km/h
floatgetspeed() {
unsigned long d1 = analogRead(sen3);
delay(speed_period * 1000);
unsigned long d2 = analogRead(sen3);
unsigned long dd = d1 > d2 ? d1 - d2 : d2 - d1;
returndd / 100.0 / speed_period * 3.6;
}
floatgetdistance(){
unsigned long d1 = analogRead(sen1);
```



```

unsigned long d2 = analogRead(sen2);
unsigned long d3 = analogRead(sen3);
unsigned long d4 = analogRead(sen4);
unsigned long d5 = analogRead(sen5);
unsigned long r = d5;
if(r>=d2) // take the smallest distance read from sensors
  r=d2;
else if(r>=d3)
  r=d3;
else if(r>=d4)
  r=d4;
else if(r>=d1)
  r=d5;
else r=d5;
return r;
}
void setup() {
  // put your setup code here, to run once:
  Serial.begin(9600);
  pinMode(brk,OUTPUT);
  pinMode(alarm,OUTPUT);
  pinMode(sen1,INPUT);
  pinMode(sen2,INPUT);
  pinMode(sen3,INPUT);
  pinMode(sen4,INPUT);
  pinMode(sen5,INPUT);
  pinMode(sw,INPUT);
  // initalizing fuzzy papmeters
  FuzzyInput* velocity = new FuzzyInput(1);
  FuzzySet* v1 = new FuzzySet(20, 20, 20, 30);
  velocity->addFuzzySet(v1);
  FuzzySet* v2 = new FuzzySet(20, 30, 30, 38);
  velocity->addFuzzySet(v2);
  FuzzySet* v3 = new FuzzySet(30, 40, 40, 48);
  velocity->addFuzzySet(v3);

```

```

FuzzySet* v4 = new FuzzySet(40, 50, 50, 60);
velocity->addFuzzySet(v4);
FuzzySet* v5 = new FuzzySet(50, 60, 60, 60);
velocity->addFuzzySet(v5);
fuzzy->addFuzzyInput(velocity);

// initalizing fuzzy papmeters
FuzzyOutput* distance = new FuzzyOutput(1);
FuzzySet* 11 = new FuzzySet(0.4, 0.4, 0.4, 1);
distance->addFuzzySet(11);
FuzzySet* 12 = new FuzzySet(0.5, 1, 1, 1.5);
distance->addFuzzySet(12);
FuzzySet* 13 = new FuzzySet(1.3, 2.9, 2.9, 3.4);
distance->addFuzzySet(13);
FuzzySet* 14 = new FuzzySet(2.9, 4, 4, 5.4);
distance->addFuzzySet(14);
FuzzySet* 15 = new FuzzySet(4, 6.8, 6.8, 6.8);
distance->addFuzzySet(15);
fuzzy->addFuzzyOutput(distance);
// initiating fuzzy rules
FuzzyRuleAntecedent* if_velocity_v1 = new FuzzyRuleAntecedent();
if_velocity_v1->joinSingle(v1);
FuzzyRuleConsequent* then_distance_11 = new FuzzyRuleConsequent();
then_distance_11->addOutput(11);
FuzzyRule* fuzzyRule01 = new FuzzyRule(1, if_velocity_v1, then_distance_11);
fuzzy->addFuzzyRule(fuzzyRule01);
FuzzyRuleAntecedent* if_velocity_v2 = new FuzzyRuleAntecedent();
if_velocity_v2->joinSingle(v2);
FuzzyRuleConsequent* then_distance_12 = new FuzzyRuleConsequent();
then_distance_12->addOutput(12);
FuzzyRule* fuzzyRule02 = new FuzzyRule(1, if_velocity_v2, then_distance_12);
fuzzy->addFuzzyRule(fuzzyRule02);
FuzzyRuleAntecedent* if_velocity_v3 = new FuzzyRuleAntecedent();
if_velocity_v3->joinSingle(v3);

```

```

FuzzyRuleConsequent* then_distance_13 = new FuzzyRuleConsequent();
then_distance_13->addOutput(13);
FuzzyRule* fuzzyRule03 = new FuzzyRule(1, if_velocity_v3, then_distance_13);
fuzzy->addFuzzyRule(fuzzyRule03);
FuzzyRuleAntecedent* if_velocity_v4 = new FuzzyRuleAntecedent();
if_velocity_v4->joinSingle(v4);
FuzzyRuleConsequent* then_distance_14 = new FuzzyRuleConsequent();
then_distance_14->addOutput(14);
FuzzyRule* fuzzyRule04 = new FuzzyRule(1, if_velocity_v4, then_distance_14);
fuzzy->addFuzzyRule(fuzzyRule04);
FuzzyRuleAntecedent* if_velocity_v5 = new FuzzyRuleAntecedent();
if_velocity_v5->joinSingle(v5);
FuzzyRuleConsequent* then_distance_15 = new FuzzyRuleConsequent();
then_distance_15->addOutput(15);
FuzzyRule* fuzzyRule05 = new FuzzyRule(1, if_velocity_v5, then_distance_15);
fuzzy->addFuzzyRule(fuzzyRule05);
}
void loop() {
float p=digitalRead(sw);
// put your main code here, to run repeatedly:
float s = getspeed(); // get car speed in km/h
float distance = getdistance() / 100;
fuzzy->setInput(1, s);
fuzzy->fuzzify();
floatsafe_fuzz_distance = fuzzy->defuzzify(1);
if (s >= 23 && s <= 32.5)safe_fuzz_distance += 1.1;
else if (s >= 46 && s <= 51.5)safe_fuzz_distance += 0.3;
elsesafe_fuzz_distance += 0.8;
if (distance >= 6 && p==HIGH ) digitalWrite(brk, LOW);
else {
if (distance <=( safe_fuzz_distance + 1)&& p==HIGH) digitalWrite(alarm,
HIGH);
elsedigitalWrite(alarm, LOW);
if (distance <= safe_fuzz_distance && p==HIGH) {
digitalWrite(brk, HIGH);
}
}
}

```

```
    }  
else if (distance >= 3 && p==HIGH) {  
digitalWrite(brk, LOW);  
    }  
}  
Serial.print("safe distance: "); Serial.print(safe_fuzz_distance);  
Serial.print(" m, speed: "); Serial.print(s);  
Serial.print(" km/h, dist: "); Serial.print(distance); Serial.println(" m");  
}
```