

Sudan University of Sciences and Technology

College of Engineering

Electrical Engineering

Pitch Control of Horizontal Axis Wind Turbines

التحكم في زاوية ميلان عنفة توربينات الرياح افقية المحور

A Project Submitted In Partial Fulfillment for the Requirements of the
Degree of B.Sc. (Honor) In Electrical Engineering

Prepared By:

1. Adam Omer Elshaib Omer
2. Almegdad Ahmed Suliman Ahmed
3. Dafalla Osman Alhadi Omer
4. Muhand AbdelRahman Ahmed Mohammed

Supervised By:

Dr. Nagm Eldeen Abdo Mustafa Hassanian

October 2017

الآية

قال تعالى :

((أَقْرَأْ بِاسْمِ رَبِّكَ الَّذِي خَلَقَ ﴿١﴾ خَلَقَ الْإِنْسَانَ مِنْ عَلَقٍ ﴿٢﴾ أَقْرَأْ وَرَبُّكَ
الْأَكْرَمُ ﴿٣﴾ الَّذِي عَلَّمَ بِالْقَلَمِ ﴿٤﴾ عَلَّمَ الْإِنْسَانَ مَا لَمْ يَعْلَمْ ﴿٥﴾))

صدق الله العظيم

سورة العلق الآيات (من ١-٥)

DEDICATION

We would like to dedicate this research:

To our parents.

To our brothers and sisters.

To people who paved our way of sciences and knowledge.

To the tastes of the most beautiful moments _ our friends.

ACKNOWLEDGEMENT

At first we are thankful and grateful for God because of this successive work. Secondly we wish to express special thanks to supervisor Dr. Nagm Eldeen Abdo Mustafa Hassanian who reworded to use his knowledge simply and made it possible for us through the knowledge and success path.

ABSTRACT

In recent years due to diminishing fossil fuels and environmental concerns wind power has become a popular renewable energy source. Pitch control is important for wind turbines to extract maximum power from available wind speed and keep power output constant at the maximum value at above rated wind speed of the wind turbine by adjusting pitch angles of wind turbine. The wind turbine is controlled using pitch angle control based on power signal feedback (PSF) method and it used the PI controller to control of pitch angle. The presented model and simulation results are tested in MATLAB/SIMULINK.

المستخلص

في السنوات الاخيرة بسبب تناقص الوقود الاحفوري والمخاوف البيئية انتشر استخدام طاقة الرياح كمصدر للطاقة المتجددة. التحكم في زاوية ميلان العنفة مهم لتوربينات الرياح لاستخراج الطاقة القصوي من سرعة الرياح المتاحة وجعل قدرة الخرج ثابتة عند القيمة القصوي عند سرعة الرياح الاكبر من سرعة الرياح المقننة لتوربينات الرياح عن طريق ضبط زاوية ميلان عنفة توربينات الرياح. للتحكم في توربينات الرياح استخدمت طريقة التغذية الراجعة لاشارة القدرة واستخدم المتحكم التفاضلي للتحكم في زاوية ميلان العنفة. استخدم برنامج الماتلاب لاعداد النموذج واختبار نتائج المحاكاة.

TABLE OF CONTENTS

	Page No.
الآية	i
DEDICATION	ii
ACKNOWLEDGEMENT	iii
ABSTRACT	iv
المستخلص	v
TABLE OF CONTENTS	vi
LIST OF FIGURE	ix
LIST OF ABBREVIATIONS	xi
LIST OF SYMBOLES	xii
CHAPTER ONE	
INTRODUCTION	
1.1 Overview	1
1.2 Problem Statement	2
1.3 Objectives	2
1.4 Methodology	3
1.5 Thesis Outline	3
CHAPTER TWO	
LITERATURE REVIEW	
2.1 Introduction	4
2.2 Wind Power Capacity and Production	5
2.3 Advantages of Wind Energy	6
2.4 Disadvantages of Wind Energy	9
2.5 Types of Wind Turbines	11
2.5.1 Horizontal axis wind turbine (HAWT)	11
2.5.2 Vertical axis wind turbines (VAWT)	13
2.6 Modern Wind Turbine Design	15

2.7 Power Captured From Wind Turbine	19
2.8 The Betz limit	20
2.9 The Performance Curves	20
2.9.1 The $C_p - \lambda$ performance curve	20
2.9.2 The effect of solidity on performance	21
2.9.3 Effect of rotational speed change	22
2.9.4 Effect of blade pitch angle change	23
2.10 Control Strategy	24
2.11 Wind Turbine Control	26
2.11.1 Pitch Control	26
2.11.2 Stall control	27
2.11.3 Power electronic control	28
2.11.4 Yaw Control	28
2.12 Control System Components	29
2.13 Pitch Actuators	30
2.14 Basic of Induction and Synchronous Machine	30
2.15 PID and PI controllers	31
CHAPTER THREE MATHEMITICAL MODEL	
3.1 Introduction	34
3.2 Wind Turbine Model	34
3.3 Induction Generator Model	35
3.4 PI Controller Model	38
3.5 Model Components	38
CHAPTER FOUR RESULTS AND DISCUSSIONS	
4.1 Introduction	42
4.2 Results at Wind Speed 14 m/s	42
4.3 Results at Wind Speed 16 m/s	45

4.4 Results at Wind Speed 18 m/s Or Above	48
CHAPTER FIVE CONCLUSION AND RECOMMENDATIONS	
5.1 Conclusion	50
5.2 Recommendations	50
REFERENCES	51
APPENDIX	53

LIST OF FIGURES

Figure No.	Title	Page No.
2.1	Global cumulative installed wind capacity 2001-2016	6
2.2	Horizontal of axis wind turbine description	11
2.3	Dutch windmills	12
2.4	Multi-blade water-pumping windmills	12
2.5	High-speed propeller type wind machines	13
2.6	Darrieus type wind turbine	14
2.7	Savonius type wind turbine	15
2.8	HAWT rotor configurations	16
2.9	Component of horizontal wind turbine	16
2.10	$C_p - \lambda$ performance curve for a modern three blade turbine	21
2.11	Effect of changing solidity	22
2.12	Effect on extracted power of rotational speed	23
2.13	Effect of pitch angle	23
2.14	Power curve	25
2.15	Feedback loop for pitch angle control	27
2.16	Propeller type wind turbine with tail van for yaw control	29
2.17	Control system components	30
2.18	Block diagram of PID controller	32
3.1	Primitive Machine	35
3.2	Model of system	41
4.1	Change in power at 14m/s	42
4.2	Change in pitch angle at 14m/s	43
4.3	Change in mechanical torque at 14m/s	43

4.4	Change in rotor speed at 14m/s	44
4.5	Change in voltage at 14m/s	44
4.6	Change in current at 14m/s	45
4.7	Change in pitch angle at 16m/s	45
4.8	Change in power at 16m/s	46
4.9	Change in mechanical torque at 16m/s	46
4.10	Change in rotor speed at 16m/s	47
4.11	Change in voltage at 16m/s	47
4.12	Change in current at 16m/s	48
4.13	Change in mechanical torque at 18m/s or above	48
4.14	Change in power at 18m/s or above	49

LIST OF ABBREVIATIONS

PSF	Power Signal Feedback
WCES	Wind Energy Conversion System
HAWT	Horizontal Axis Wind Turbines
VAWT	Vertical Axis Wind Turbines
SQIG	Squirrel Cage Induction Generator
DFIG	Doubly Fed Induction Generator
TSR	Tip Speed Ratio
PID	Proportional–Integral–Derivative
PI	Proportional–Integral
AC	Alternating Current

LIST OF SYMBOLS

P	The power in the wind, W
ρ	The air density, kg/m ³
A	The area swept by blades, m ²
v	Wind speed, m/s
P_{wt}	The mechanical power of the wind turbine, W
C_p	Power coefficient of the wind turbine
β	The blade pitch angle, degree
λ	The tip speed ratio
ω_{wt}	The turbine rotor speed, rad/s
R	The radius of the wind turbine blade, m
J	The polar moment of inertia of the rotor, kg-m ²
P_m	Mechanical power, W
P_e	Electrical power, W
K_p	Proportional gains
K_i	Integral gains
K_d	Derivative gains
T_d	Derivative time
V	The voltages, volt
Z	The impedance, Ω
I	The currents, A
R	The resistance, Ω
L	The inductance, H
ρ	d/dt
G	The conductivity, S
ω_r	Rotor speed, rad/s
M	Mutual inductance, H

CHAPTER ONE

INTRODUCTION

1.1 Overview

Wind systems comprise generally a wind turbine, which is installed on top of a tall tower, collects kinetic energy from the wind and converts it to electricity. The power price has considerably decreased since the last decade. This leads to a large-scale application of wind systems in several promising areas. Compared with conventional fossil energy sources, small wind energy systems are the best option for many isolated or rural areas applications around the world. However, because wind energy is an intermittent and a variable source of energy, stand-alone turbines generally can use another source of energy to provide constant power, such as solar photovoltaic or hydro [1].

Wind energy is a renewable, clean, and free energy source for energy production. Wind energy conversion system (WCES) requires no connection to an existing power source, and they could be combined with other power sources to increase system reliability and could be installed and upgraded as wind farm; more wind turbine could be added as power demand increases. The first new modern wind turbines were in 1979, and their power capacities were around 10–30 kW. Wind power technologies can be classified as follows [1]:

- 1- By axis wind turbine [horizontal axis wind turbines (HAWT) or vertical axis wind turbines (VAWT)].
- 2- By localization (onshore or offshore).

The pitch control system is one of the most widely used control techniques to regulate the output power of a wind turbine generator. The pitch function gives

full control over the mechanical power and if the most common method is used for the variable speed wind turbines.

Now most of turbines use pitch to control power captured by the rotor. Blade derived and controlled by a servo system according to demand come from main controller according to different operating conditions. A lot of advanced intelligent control algorithms had been used in pitch control. Even intelligent control algorithms applied, the traditional collective pitch control strategies move the three blades synchronal. At present, electrical servo system and hydraulic servo system are used to drive blade in most of turbine pitch system. Three blades can be controlled independently with three motors or cylinders, which make it possible to decrease the rotor unbalanced load by controlling pitch angle independently [2-4].

1.2 Problem Statement

Problems of wind speed is a variable, this makes electric power generator is variable between high and low depending on wind speed.

The second problem is occurs at high wind speed the wind turbine will be damage and burning.

1.3 Objectives

- 1- The main objective is to get maximum energy at wind speeds lower than rated wind speed.
- 2- The power output is kept constant at the maximum value at above rated wind speed of the wind turbine.
- 3- At higher wind speed we use emergency stop to avoid damage and burning of turbine.

1.4 Methodology

The mathematical model of wind turbine of asynchronous machine is built and it use PI controller to control of pitch angle. The Matlab/ Simulink program is used to simulate the system.

1.5 Thesis Outline

This thesis consists of five chapters:

Chapter one: Introduction, Problem and objective of research and methodology. **Chapter two:** Presents the literature review of wind energy, type of wind turbine, wind turbine design, the performance curve, control strategy, wind turbine control, Asynchronous machine, PID and PI controllers.

Chapter three: Presents the mathematical models of variable speed wind turbine, induction generator, PI controller and explain the benefits of each components of the model.

Chapter four: Result of applied the pitch angle control to extract maximum power from available wind speed, keep the power output constant at high wind speed and stop turbine at higher wind speed using PI controller.

Chapter five: Conclusion and recommendation.

CHAPTER TWO

LITERATURE REVIEW

2.1 Introduction

Wind energy is the fastest growing source of renewable energy, as the worldwide production has doubled between 2005 and 2008, reaching 121.2 GW of total installed capacity. The transformation of wind power into electrical power is performed by wind turbines, which are usually grouped into wind farms in order to exploit considerations relative to economies of scale, such as lower installation and maintenance costs. But as costs decrease, grouping turbines leads to a reduction in the power produced because of the presence of wake effects within the wind farm. When a turbine extracts power from the wind, it generates a “wake” of turbulence that propagates downwind, so that the wind speed and therefore the power extracted by the turbines affected are reduced. In large wind farms wake effects lead to considerable power loss and thus it is desirable to minimize them in order to maximize the expected power output.

Wind power has been used as long as humans have put sails into the wind. For more than two millennia wind-powered machines have ground grain and pumped water. Wind power was widely available and not confined to the banks of fast-flowing streams, or later, requiring sources of fuel. Wind-powered pumps drained the polders of the Netherlands, and in arid regions such as the American mid-west or the Australian outback, wind pumps provided water for livestock and steam engines.

The first windmill used for the production of electric power was built in Scotland in July 1887 by Prof James Blyth. Blyth's 10 meters (33 ft.) high, cloth-sailed wind turbine was installed in the garden of his holiday cottage at

Marykirk and was used to charge accumulators developed by the Frenchman Camille Alphonse Faure, to power the lighting in the cottage, thus making it the first house in the world to have its electric power supplied by wind power. Blyth offered the surplus electric power to the people of Marykirk for lighting the main street. Although he later built a wind turbine to supply emergency power.

Across the Atlantic, in Cleveland, Ohio a larger and heavily engineered machine was designed and constructed in the winter of 1887–1888 by Charles F. Brush, this was built by his engineering company at his home and operated from 1886 until 1900. The Brush wind turbine had a rotor 17 meters (56 ft.) in diameter and was mounted on an 18 meters (59 ft.) tower. Although large by today's standards, the machine was only rated at 12 kW. The connected dynamo was used either to charge a bank of batteries or to operate up to 100 incandescent light bulbs, three arc lamps, and various motors in Brush's laboratory.

With the development of electric power, wind power found new applications in lighting buildings remote from centrally-generated power. Throughout the 20th century parallel paths developed small wind stations suitable for farms or residences, and larger utility-scale wind generators that could be connected to electric power grids for remote use of power. Today wind powered generators operate in every size range between tiny stations for battery charging at isolated residences, up to near-gigawatt sized offshore wind farms that provide electric power to national electrical networks [5-7].

2.2 Wind Power Capacity and Production

Worldwide there are now over two hundred thousand wind turbines operating, with a total nameplate capacity of 432 GW as of end 2015. The European Union alone passed some 100 GW nameplate capacity in September 2012, while the United States surpassed 75 GW in 2015 and China's grid connected capacity passed 145 GW in 2015.

World wind generation capacity more than quadrupled between 2000 and 2006, doubling about every three years [8, 9].

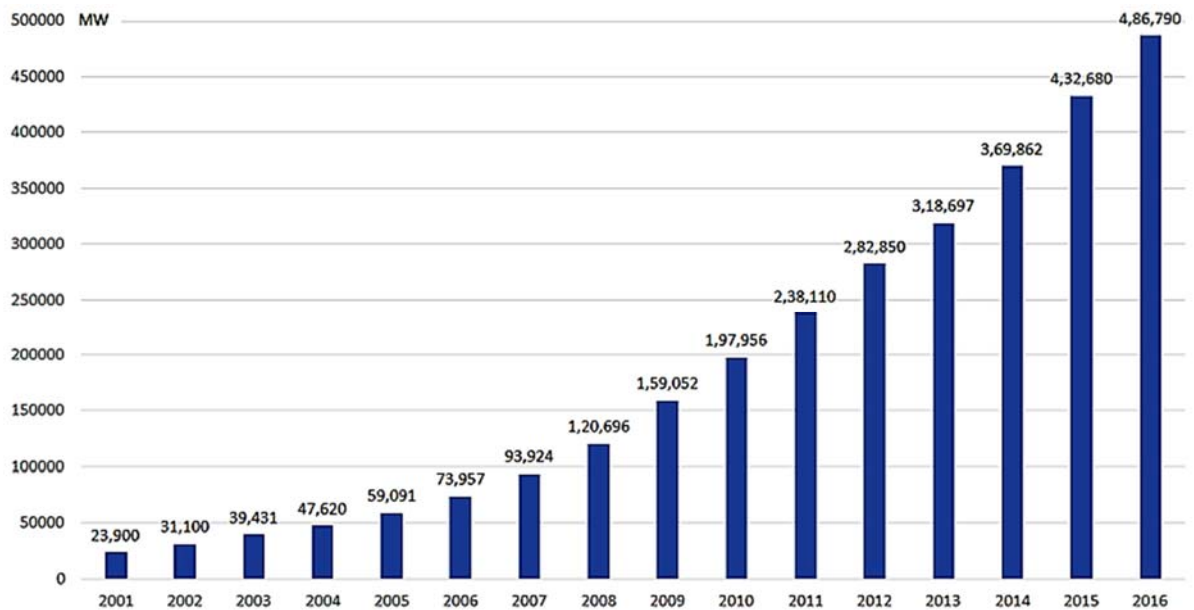

Figure 2.1: Global cumulative installed wind capacity 2001-2016

2.3 Advantages of Wind Energy

Wind energy has numerous benefits in helping to provide a source of clean and renewable electricity for countries all over the world. This section takes a look at the many different advantages of wind energy [10, 11].

2.3.1 Renewable and sustainable

Wind energy itself is both renewable and sustainable. The wind will never run out, unlike the earth's fossil fuel reserves (such as coal, oil and gas), making it the ideal energy source for a sustainable power supply.

2.3.2 Environmentally friendly

Wind energy is one of the most environmentally friendly energy sources available today. After the manufacture and installation of wind turbines, there will be little to no pollution generated as a result of the wind turbines themselves.

Wind turbines produce no greenhouse gases such as carbon dioxide (CO₂) or methane (CH₄) which are both known to contribute towards global warming.

It should be noted that noise and visual pollution are both environmental factors, but they don't have a negative effect on the earth, water table or the quality of the air we breathe.

2.3.3 Reduces fossil fuel consumption

Generating electricity from wind energy reduces the need to burn fossil fuel alternatives such as coal, oil and gas. This can help to conserve dwindling supplies of the earth's natural resources, allowing them to last longer and help to support future generations.

2.3.4 Wind energy is free

Unlike some other energy sources, wind energy is completely free. There's no market for the supply and demand of wind energy, it's there to be used by anyone and will never run out. This makes wind energy a viable option for generating cheap electricity.

2.3.5 Small footprint

Wind turbines have a relatively small land footprint. Although they can tower high above the ground, the impact on the land at the base is minimal. The area around the base of a wind turbine can often be used for other purposes such as agriculture.

2.3.6 Industrial and domestic installations

Wind turbines aren't just limited to industrial-scale installations such as wind farms. They can also be installed on a domestic scale, with many landowners opting to install smaller, less powerful wind turbines in order to provide part of a domestic electricity supply. Domestic wind turbines are often coupled with other renewable energy technologies such as solar panels or geothermal heating systems.

2.3.7 Remote power solution

Wind turbines can play a key role in helping to bring power to remote locations. This can help to benefit everything from a small off-grid village to a remote research station.

2.3.8 Wind technology becoming cheaper

The first ever electricity-generating wind turbine was invented in 1888. Since then, wind turbines have improved significantly and nowadays the technology is beginning to come down in price, making it much more accessible.

Government subsidies are also helping to reduce the cost of a wind turbine installation, with many governments across the world providing incentives for not only the installation of such technologies, but also for the ongoing supply of environmentally friendly electricity.

2.3.9 Low maintenance

Wind turbines are considered relatively low maintenance. A new wind turbine can be expected to last some time prior to any maintenance work needing to be carried out. Although older wind turbines can come up against reliability issues, each new generation of wind turbine is helping to improve reliability.

2.3.10 Low running costs

As wind energy is free, running costs are considered to be low. The only ongoing cost associated with wind energy is for the maintenance of wind turbines, which are considered low maintenance in nature anyway.

2.3.11 Increases energy security

By using wind energy to generate electricity, we are helping to reduce our dependency on fossil fuel alternatives such as coal, oil and gas. In many cases, these natural resources are often sourced from other countries.

War, politics and overall demand often dictate the price for natural resources, which can fluctuate and cause serious economic problems or supply shortages

for some countries. By using renewable energy sources a country can help to reduce its dependency on global markets and thus increase its energy security.

2.3.12 Job creation

The wind energy industry has boomed since wind turbines first became available on the market. This has helped to create jobs all over the world. Jobs have been created for the manufacture of wind turbines, the installation and maintenance of wind turbines and also in wind energy consulting, where specialist consultants will determine whether or not a wind turbine installation will provide a return on investment.

2.4 Disadvantages of Wind Energy

So, we've seen the advantages, now it's time to take a look at the main disadvantages of wind energy.

2.4.1 The wind fluctuates

Wind energy has a similar drawback to solar energy in that it is not a constant energy source. Although wind energy is sustainable and will never run out, the wind isn't always blowing. This can cause serious problems for wind turbine developers who will often spend significant time and money investigating whether or not a particular site is suitable for the generation of wind power.

For a wind turbine to be efficient, the location where it is built needs to have an adequate supply of wind energy. This is why we often see wind turbines built on top of hills or out at sea, where there are less land obstacles to reduce the intensity of wind energy.

2.4.2 Installation is expensive

Although costs are reducing over time, the installation of a wind turbine is considered expensive. First, a site survey will need to be carried out which may involve having to erect a sample turbine to measure wind speeds over a significant period of time. If deemed adequate, the wind turbine will need to

be manufactured, transported and erected on top of a pre-built foundation. All of these processes contribute to the overall cost of installing a wind turbine.

When the above is taken into account for offshore wind farms, costs become much greater. It's much harder to install wind turbines out at sea than it is on land, and some companies have even commissioned bespoke ships capable of transporting and installing wind turbines at sea.

2.4.3 Threat to wildlife

It's widely reported that wind turbines pose a threat to wildlife, primarily birds and bats. It is however believed that wind turbines pose less of a threat to wildlife than other manmade structures such as cell phone masts and radio towers. Nevertheless, wind turbines are contributing to mortality rates among bird and bat populations.

2.4.4 Noise pollution

One of the most popular disadvantages of wind turbines is the noise pollution that they generate. A single wind turbine can be heard from hundreds of meters away. Combine multiple wind turbines and the audible effects can be much greater.

Noise pollution from wind turbines has ruined the lives of some homeowners. Although steps are often taken to site wind turbines away from dwellings, they do sometimes get built too close to where people live and this is why new wind farms often come up against strong public objection.

2.4.5 Visual pollution

Another widely reported disadvantage of wind turbines is visual pollution. Although many people actually like the look of wind turbines, others do not and see them as a blot on the landscape. This tends to come down to personal opinion, and as more wind farms are built, public acceptance is becoming commonplace.

2.5 Types of Wind Turbines

Wind turbines can be classified into two types:

1. Horizontal axis wind turbine.
2. Vertical axis wind turbine.

2.5.1 Horizontal axis wind turbine (HAWT)

HAWT is the most used. It is mounted on towers. The main advantages of the HAWT are its high efficiency and low cost/power ratio. Its drawbacks are the complex design and the difficulties in maintenance because generator and gearbox should be mounted on a tower [1].

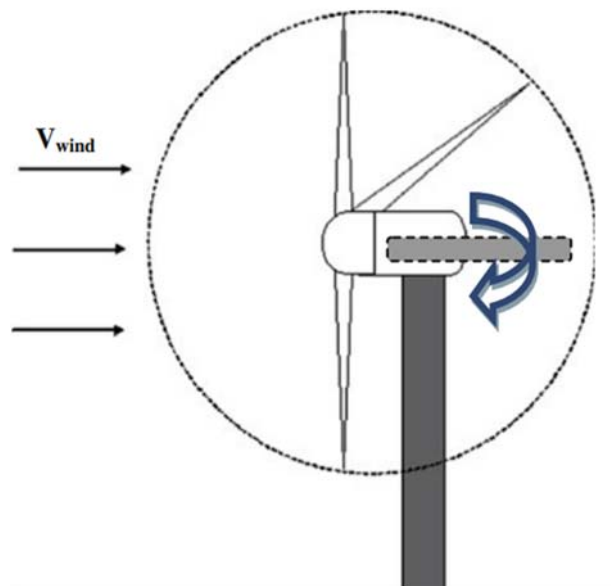

Figure (2.2): Horizontal of axis wind turbine description

The types of horizontal axis wind turbines are:

2.5.1.1 Dutch windmills

Dutch windmills has used for a long time. In fact, the grain-grinding windmills that were widely used in Europe since the middle ages were Dutch. These windmills operated on the thrust exerted by wind. The blades, generally four, were inclined at an angle to the plane of rotation. The wind, being deflected by

the blades, exerted a force in the direction of rotation. The blades were made of sails or wooden slats. It was found that certain modifications in the earlier design of windmills make them very useful for pumping water [12].

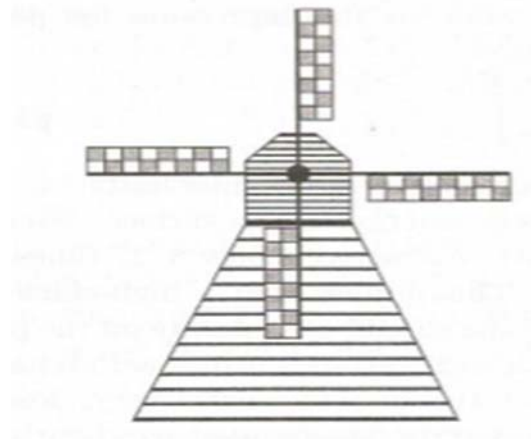

Figure 2.3: Dutch windmills

2.5.1.2 Multi-blade water-pumping windmills

Modern water-pumping windmills have a large number of blades- generally wooden or metallic slats-driving a reciprocating pump as the mill has to be placed directly over for site selection concerns water availability and not windiness. Therefore, the mill must be able to operate at slow winds. The large number of blades give a high torque, required for driving a centrifugal pump, even at low winds. Hence sometimes these are called fan-mills [12].

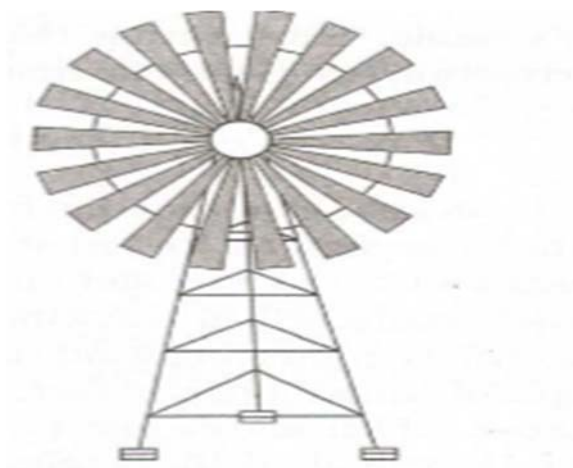

Figure 2.4: Multi-blade water-pumping windmills

2.5.1.3 High-speed propeller type wind machines

The horizontal-axis wind turbines that are used today for electrical power generation do not operate on thrust force. They depend mainly on the aerodynamic forces that develop when wind flows around a blade of aerofoil design. As has been shown already. Windmills working on thrust force are inherently less efficient [12].

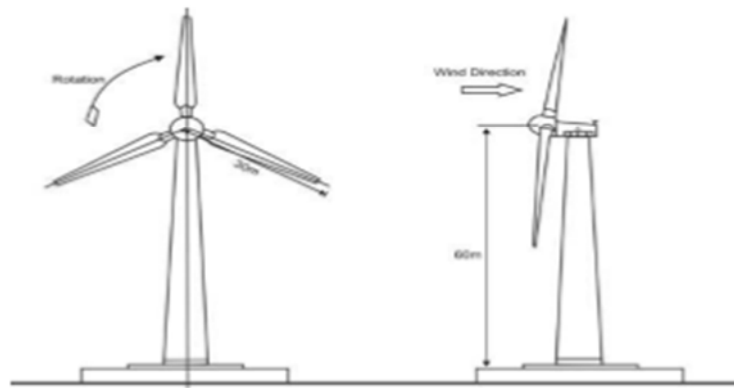

Figure 2.5: High-speed propeller type wind machines

2.5.2 Vertical axis wind turbines (VAWT)

This type of wind turbine rotates about an axis that is perpendicular to the oncoming flow, hence, it can take wind from any direction. VAWT consist of two major types, the Darrieus rotor and Savonius rotor. The Darrieus wind turbine is a VAWT that rotates around a central axis due to the lift produced by the rotating airfoils, whereas a Savonius rotor rotates due to the drag created by its blades. There is also a new type of VAWT emerging in the wind power industry which is a mixture between the Darrieus and Savonius designs [13].

The types of vertical axis wind turbines are:

2.5.2.1 Darrieus type wind turbine

In 1931, a vertical-axis device for wind energy conversion was invented by G.J. Darrieus of the United States, but was forgotten for a long time. The energy crisis renewed interest in windmill development in the 1970s, which reinvented the use of the Darrieus rotor for wind energy conversion. The peculiarity of the Darrieus rotor is that its working is not at all evident from its appearance. Two or more flexible blades are attached to a vertical shaft as shown in Figure 2.6. [12].

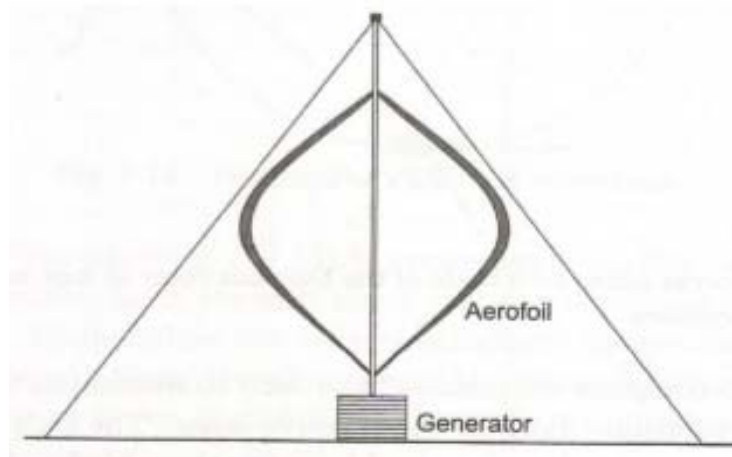

Figure 2.6: Darrieus type wind turbine

2.5.2.2 Savonius type wind turbine

The Savonius rotor is an extremely simple vertical-axis device that works entirely because of the thrust force of wind. The basic equipment is a drum cut into two halves vertically. The two parts are attached to the two opposite sides of a vertical shaft.

The Savonius rotor is inexpensive and simple, and the material required for it is generally available in any rural area, enabling on-site construction of such windmills. However, its utility is limited to pumping water because of its relatively low efficiency [12].



Figure 2.7: Savonius type wind turbine

2.6 Modern Wind Turbine Design

Today, the most common design of wind turbine, and the type which is the primary focus of this project, is the horizontal axis wind turbine (HAWT). That is, the axis of rotation is parallel to the ground. HAWT rotors are usually classified according to the rotor orientation (upwind or downwind of the tower), hub design (rigid or teetering), rotor control (pitch or stall), number of blades (usually two or three blades), and how they are aligned with the wind (free yaw or active yaw) [14].

Figure 2.8 shows the upwind and downwind configurations. The principal subsystems of a typical (land-based) horizontal axis wind turbine are shown in Figure 2.9. These include:

1. The rotor, consisting of the blades and the supporting hub.
2. The drivetrain, which includes the rotating parts of the wind turbine (exclusive of the rotor); it usually consists of shafts, gearbox, coupling, a mechanical brake, and the generator.
3. The nacelle and main frame, including wind turbine housing, bedplate, and the yaw system.
4. The tower and the foundation.
5. The machine controls.

6. The balance of the electrical system, including cables, switchgear, transformers, and possibly electronic power converters.

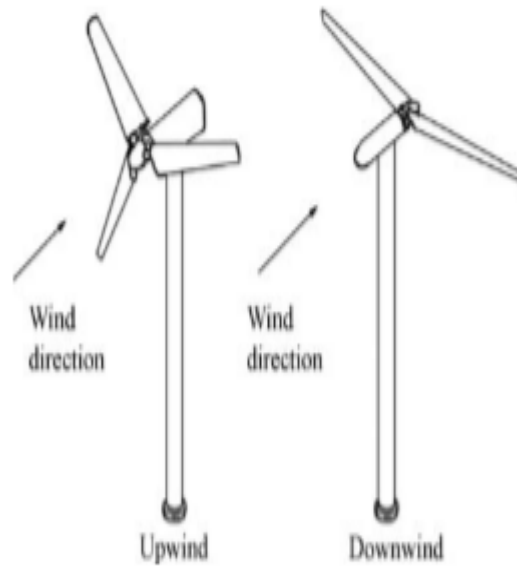

Figure 2.8: HAWT rotor configurations

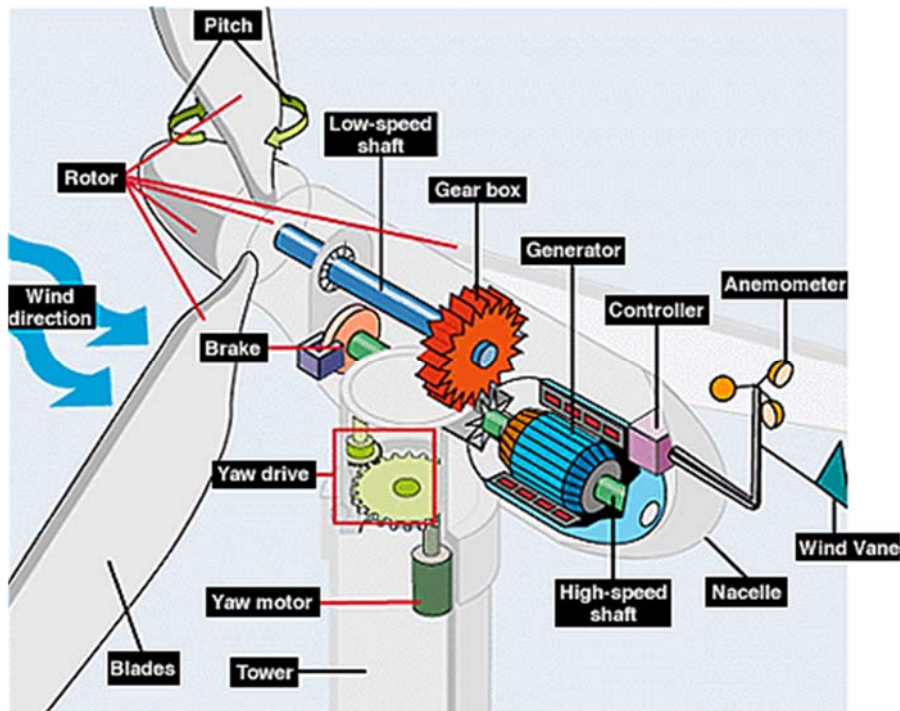

Figure 2.9: Component of horizontal wind turbine

The main options in wind turbine design and construction include:

- 1- Number of blades (commonly two or three).
- 2- Rotor orientation: downwind or upwind of tower.
- 3- Blade material, construction method, and profile.
- 4- Hub design: rigid, teetering, or hinged.
- 5- Power control via aerodynamic control (stall control) or variable-pitch blades (pitch control).
- 6- Fixed or variable rotor speed.
- 7- Orientation by self-aligning action (free yaw), or direct control (active yaw).
- 8- Synchronous or induction generator (squirrel cage or doubly fed).
- 9- Gearbox or direct drive generator.

A short introduction to and overview of some of the most important components follows.

2.6.1 Rotor

The rotor consists of the hub and blades of the wind turbine. These are often considered to be the turbine's most important components from both a performance and overall cost standpoint.

Most turbines today have upwind rotors with three blades. There are some downwind rotors and a few designs with two blades. Single-blade turbines have been built in the past, but are no longer in production. Some intermediate-sized turbines used fixed-blade pitch and stall control. Most manufacturers use pitch control, and the general trend is the increased use of pitch control, especially in larger machines. The blades on the majority of turbines are made from composites, primarily fiberglass or carbon fiber reinforced plastics (GRP or CFRP), but sometimes wood/epoxy laminates are used [14].

2.6.2 Drive train

The drive train consists of the other rotating parts of the wind turbine downstream of the rotor. These typically include a low-speed shaft (on the

rotor side), a gearbox, and a high-speed shaft (on the generator side). Other drive train components include the support bearings, one or more couplings, a brake, and the rotating parts of the generator. The purpose of the gearbox is to speed up the rate of rotation of the rotor from a low value (tens of rpm) to a rate suitable for driving a standard generator (hundreds or thousands of rpm). Two types of gearboxes are used in wind turbines: parallel shaft and planetary [14].

2.6.3 Generator

Nearly all wind turbines use either induction or synchronous generators. These designs entail a constant or nearly constant rotational speed when the generator is directly connected to a utility network. If the generator is used with power electronic converters, the turbine will be able to operate at variable speed. Many wind turbines installed in grid connected applications use squirrel cage induction generators (SQIG). A SQIG operates within a narrow range of speeds slightly higher than its synchronous speed.

The main advantages of this type of induction generator are that it is rugged, inexpensive, and easy to connect to an electrical network.

An increasingly popular option today is the doubly fed induction generator (DFIG). The DFIG is often used in variable-speed applications [14].

2.6.4 Tower and foundation

This category includes the tower itself and the supporting foundation. The principal types of tower design currently in use are the free-standing type using steel tubes, lattice (or truss) towers, and concrete towers. For smaller turbines, guyed towers are also used. Tower height is typically 1 to 1.5 times the rotor diameter, but in any case is normally at least 20m [14].

2.6.5 Balance of electrical systems

In addition to the generator, the wind turbine system utilizes a number of other electrical components. Some examples are cables, switchgear, transformers, power electronic converters, power factor correction capacitors, yaw and pitch motors [14].

2.7 Power Captured From Wind Turbine

The power in the wind is proportional to the cube of the wind speed and can be expressed as:

$$P = 0.5\rho Av^3 \quad (2.1)$$

Where ρ is air density, A is the area swept by blades and v is wind speed.

A wind turbine can only extract part of the power from the wind, which is limited by the Betz limit (maximum 59%). This fraction is described by the power coefficient of the turbine, which is a function of the blade pitch angle and the tip speed ratio. Therefore, the mechanical power of the wind turbine extracted from the wind is:

$$P_{wt} = 0.5 \rho Av^3 C_p(\beta, \lambda) \quad (2.2)$$

Where C_p is the power coefficient of the wind turbine, β is the blade pitch angle and λ is the tip speed ratio. The value of C_p is highly non-linear and varies with the wind speed, the rotational speed of the turbine, and the turbine blade parameters such as a pitch angle.

Value of the $C_p(\beta, \lambda)$ is calculated as:

$$C_p = 0.5176\left(\frac{116}{\lambda_i} - 0.4\beta - 5\right)e^{\frac{-21}{\lambda_i}} + 0.0068 \lambda \quad (2.3)$$

Where:

$$\frac{1}{\lambda_i} = \frac{1}{\lambda + 0.08\beta} - \frac{0.035}{\beta^3 + 1} \quad (2.4)$$

The tip speed ratio is defined as the ratio between the blade tip speed and the wind speed

$$\lambda = \frac{w_{wt}R}{v} \quad (2.5)$$

Where w_{wt} the turbine rotor speed, and R is the radius of the wind turbine blade. Thus any change in the rotor speed or the wind speed induces a change in the tip speed ratio leading to power coefficient variation.

2.8 The Betz limit

The maximum achievable value of the power coefficient is known as the Betz limit. No wind turbine has been designed which is capable of exceeding this limit. The limit is caused not by any deficiency in design, for, as yet, we have no design, but because the stream-tube has to expand upstream of the actuator disc and so the cross section of the tube where the air is at the full, free-stream velocity is smaller than the area of the disc. C_p could, perhaps, more fairly be defined as [15]:

$$C_P = \frac{\text{Power extracted}}{\text{Power available}} \quad (2.6)$$

$$C_{P_{max}}=0.593$$

2.9 The Performance Curves

The performance of a wind turbine can be characterized by the manner in which the three main indicators power, torque and thrust vary with wind speed. The power determines the amount of energy captured by the rotor, the torque developed determines the size of the gear box and must be matched by whatever generator is being driven by the rotor.

2.9.1 The $C_p - \lambda$ performance curve

The first point to notice is that the maximum value of C_p is only 0.47, achieved at a tip speed ratio of 7, which is much less than the Betz limit. The discrepancy is caused, in this case, by drag and tip losses but the stall also reduces the C_p at low values of the tip speed ratio (Figure 2.10).

Even with no losses included in the analysis the Betz limit is not reached because the blade design is not perfect [16].

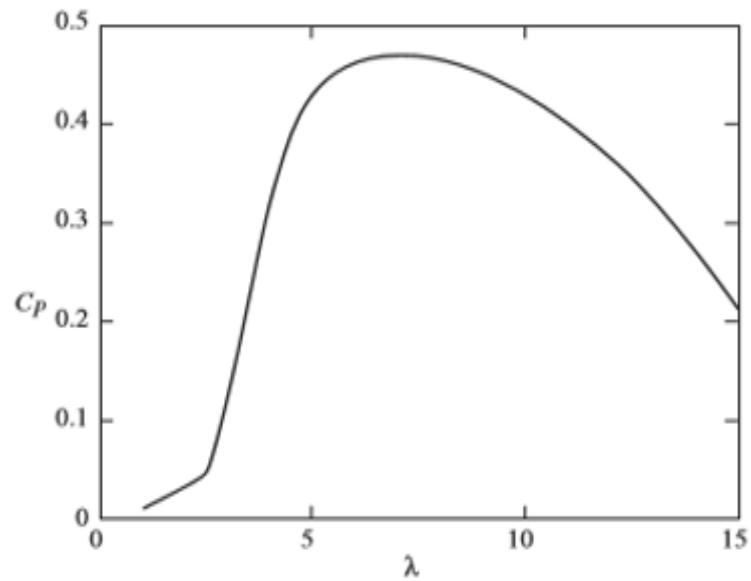

Figure 2.10: $C_p - \lambda$ performance curve for a modern three blade turbine

2.9.2 The effect of solidity on performance

The other principal parameter to consider is the solidity, defined as total blade area divided by the swept area. For the three-blade machine above the solidity is 0.0345 but this can be altered readily by changing its number of blades. The solidity could also have been changed by changing the blade chord [15].

The main effects to observe of changing solidity are as follows, see Figure 2.11.

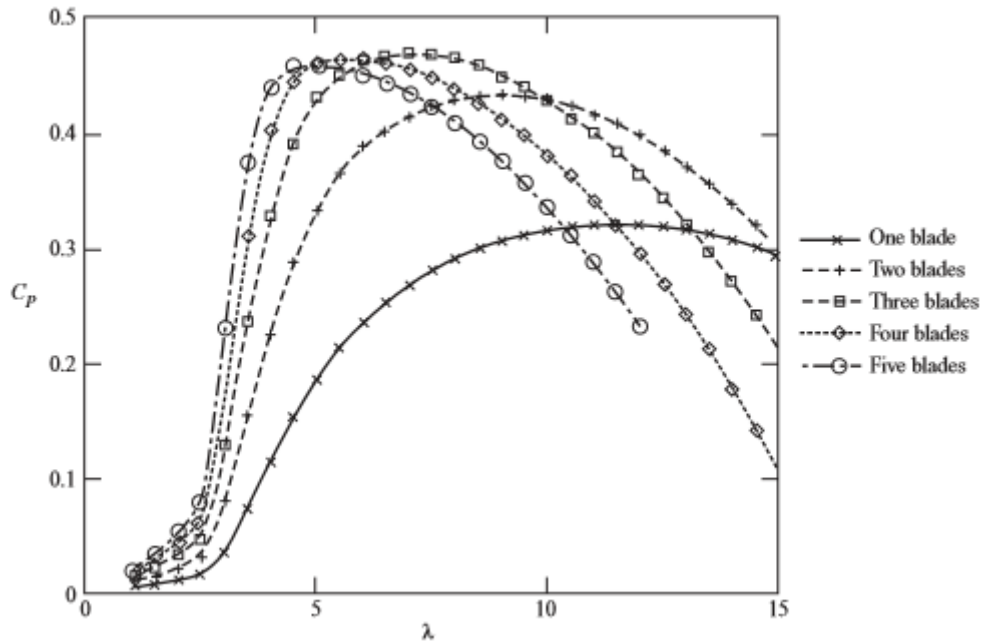

Figure 2.11: Effect of changing solidity

(1) Low solidity produces a broad, flat curve which means that the C_p will change very little over a wide tip speed ratio range but the maximum C_p is low because the drag losses are high (drag losses are roughly proportional to the cube of the tip speed ratio) [15].

(2) High solidity produces a narrow performance curve with a sharp peak making the turbine very sensitive to tip speed ratio changes and, if the solidity is too high, has a relatively low maximum C_p . The reduction in C_p max is caused by stall losses [15].

(3) An optimum solidity appears to be achieved with three blades, but two blades might be an acceptable alternative because although the maximum C_p is a little lower the spread of the peak is wider and that might result in a larger energy capture [15].

2.9.3 Effect of rotational speed change

The power output of a turbine running at constant speed is strongly governed by the chosen, operational rotational speed. If a low rotation speed is used the power reaches a maximum at a low wind speed and consequently it is very low. To extract energy at wind speeds higher than the stall peak the turbine must operate in a stalled condition and so is very inefficient. Conversely, a

turbine operating at a high speed will extract a great deal of power at high wind speeds but at moderate wind speeds it will be operating inefficiently because of the high drag losses [15].

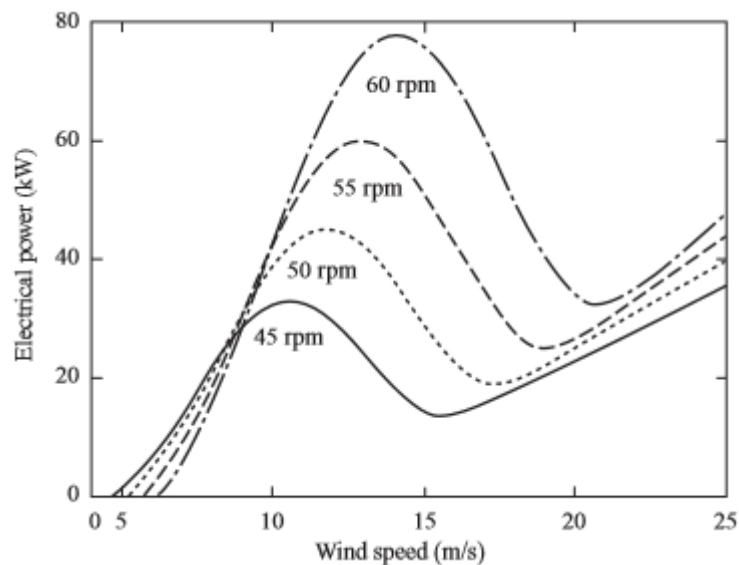

Figure 2.12: Effect on extracted power of rotational speed

2.9.4 Effect of blade pitch angle change

Another parameter which affects the power output is the pitch setting angle of the blades β . Blade designs almost always involve twist but the blade can be set at the root with an overall pitch angle [15]. The effects of a few degrees of pitch are shown in Figure 2.13.

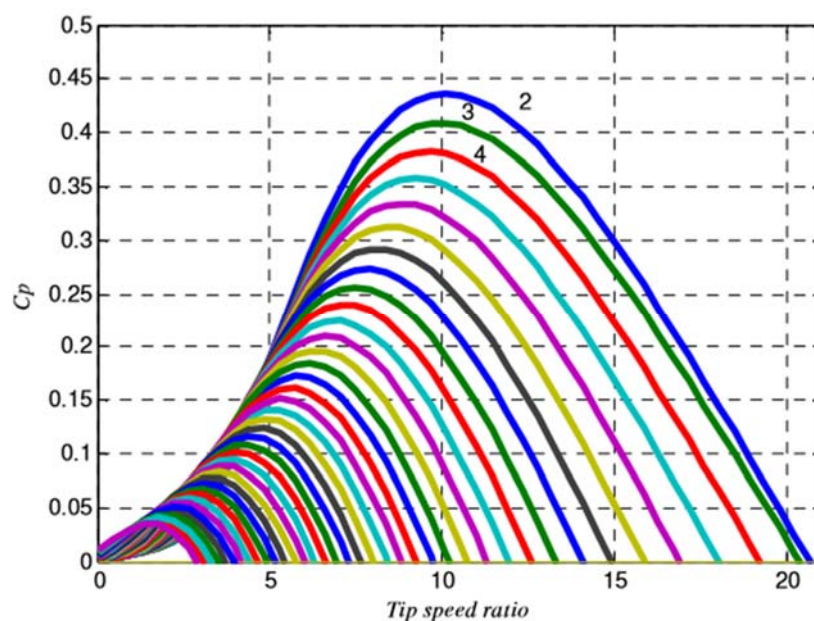

Figure 2.13: Effect of pitch angle

2.10 Control Strategy

For every wind turbine, there are five different ranges of wind speed, which require different speed control strategies [12]:

- 1- Below a cut-in speed, the machine does not produce power. If the rotor has a sufficient starting torque, it may start rotating below this wind speed. However, no power is extracted and the rotor rotates freely. In many modern designs the aerodynamic torque produced at the standstill condition is quite low and the rotor has to be started (by working the generator in the motor mode) at the cut-in wind speed.
 - 2- At normal wind speeds, maximum power is extracted from wind. We have seen earlier that the maximum power point is achieved at a specific (constant) value of the TSR. Therefore to track the maximum power point, the rotational speed has to be changed continuously in proportion to the wind speed.
 - 3- At high winds, the rotor speed is limited to a maximum value depending on the design limit of the mechanical components. In this region, the C_p is lower than the maximum, and the power output is not proportional to the cube of the wind speed.
 - 4- At even higher wind speeds, the power output is kept constant at the maximum value allowed by the electrical components.
 - 5- At a certain cut out or furling wind speed, the power generation is shut down and the rotation stopped in order to protect the system components.
- Cut-in speed: The minimum wind speed at which the machine will deliver useful power.
 - Rated wind speed: The wind speed at which the rated power (generally the maximum power output of the electrical generator) is reached.

- Cut-out speed: The maximum wind speed at which the turbine is allowed to deliver power (usually limited by engineering design and safety constraints).

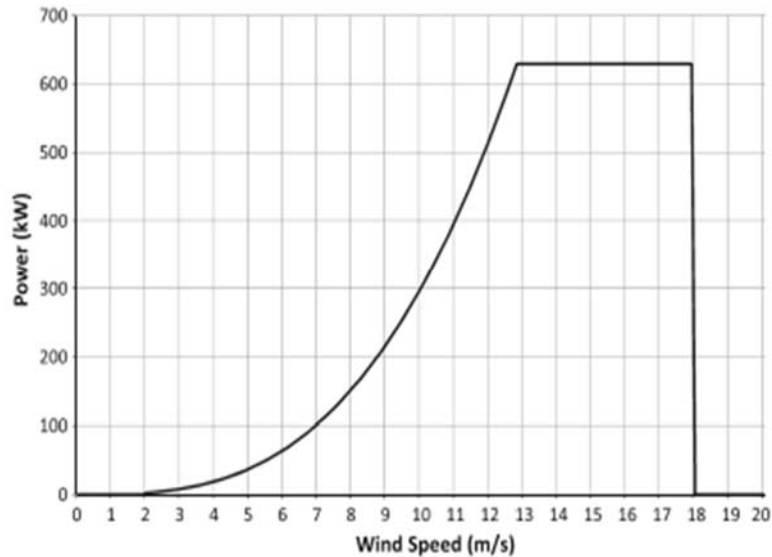

Figure 2.14: Power curve

In the intermediate-speed range, the control strategy depends on the type of electrical power generating system used, and can be divided into two basic categories:

- 1- The constant-speed generation scheme, and
- 2- The variable-speed generation scheme.

The constant-speed generation scheme is necessary if the electrical system involves a grid-connected synchronous generator. In the case of grid-connected squirrel cage induction generators, the allowable range of speed variation is very small, requiring an almost constant rotational speed.

However, constant-speed generation systems cannot maximize the extraction of the power contained in wind. We can see that the power coefficient reaches a maximum at a specific value of TSR for every type of wind turbine. Therefore, to extract the maximum amount of power from the wind, the turbine should operate at a constant TSR, which means that the rotational speed should be proportional to the wind speed. Hence the extraction of maximum power

requires a variable-speed generation system with the speed control aimed at keeping constant TSR [12].

2.11 Wind Turbine Control

The main objective of wind turbine control is to make wind power production economically more efficient. Wind turbines with rudimentary control systems that aim to minimize cost and maintenance of the installation have predominated for a long time.

Wind turbines have four different types of control mechanisms.

2.11.1 Pitch control

This system changes the pitch angle of the blades according to the variation of wind speed. With pitch control, it is possible to achieve a high efficiency by continuously aligning the blade in the direction of the relative wind.

On a pitch-controlled machine, as the wind speed exceeds its rated speed, the blades are gradually turned about the longitudinal axis and out of the wind to increase the pitch angle. This reduces the aerodynamic efficiency of the rotor, and the rotor output power decreases. When the wind speed exceeds the safe limit for the system, the pitch angle is so changed that the power output reduces to zero and the machine shifts to the 'stall' mode. After the gust passes, the pitch angle is reset to the normal position and the turbine is restarted. At normal wind speeds, the blade pitch angle should ideally settle to a value at which the output power equals the rated power [12].

The modern wind turbines implement pitch control in order to:

- 1- Get maximum energy at wind speeds lower than rated wind speed.
- 2- Keep the power output close to the rated power of the generator.
- 3- Emergency stop to avoid burning of turbine.
- 4- At even higher wind speeds, the power output is kept constant at the maximum value.
- 5- It allows lighter design and long lifetime.

On a pitch controlled wind turbine the turbine's electronic controller checks the power output of the turbine several times per second. When the power output becomes too high, it sends an order to the blade pitch mechanism which immediately pitches(turns) the rotor blades slightly out of the wind. Conversely, the blades are turned back into the wind whenever the wind drops again [12].

Figure 2.15 shows how to control the pitch angle.

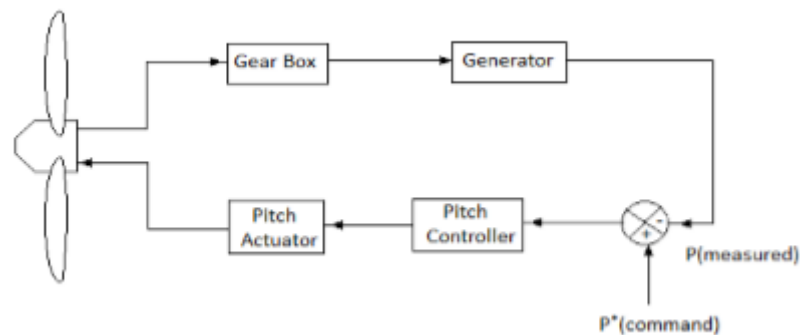

Figure 2.15: Feedback loop for pitch angle control

2.11.2 Stall control

2.11.2.1 Passive stall control

Generally, stall control to limit the power output at high winds is applied to constant pitch turbines driving induction generators connected to the network. The rotor speed is fixed by the network, allowing only 1-4% variation. As the wind speed increases, the angle of attack also increases for a blade running at a near constant speed. Beyond a particular angle of attack, the lift force decreases, causing the rotor efficiency to drop. This lift force can be further reduced to restrict the power output at high winds by properly shaping the rotor blade profile to create turbulence on the rotor blade side not facing the wind [12].

2.11.2.2 Active stall control

In this method of control, at high wind speeds, the blade is rotated by a few degrees in the direction opposite to that in a pitch controlled machine. This

increases the angle of attack, which can be controlled to keep the output power at its rated value at all high wind speeds below the furling speed [12].

2.11.3 Power electronic control

In a system incorporating a power electronic interface between the generator and load (or the grid), the electrical power delivered by the generated to the load can be dynamically controlled. The instantaneous difference between mechanical power and electrical power changes the rotor speed following the equation:

$$J \frac{d\omega}{dt} = P_m - P_e \quad (2.7)$$

Where J is the polar moment of inertia of the rotor, ω is the angular speed of the rotor, P_m is the mechanical power produced by the turbine, and P_e is the electrical power delivered to the load [12].

2.11.4 Yaw control

Turbines whether upwind or downwind, are generally stable in yaw in the sense that if the nacelle is free to yaw, the turbine will naturally remain pointing into the wind. However, it may not point exactly into wind, in which case some active control of the nacelle angle may be needed to maximize the energy capture. Since a yaw drive is usually required anyway, e.g. for start-up and for unwinding the pendant cable, it may as well be used for active yaw tracking. Free yaw has the advantage that it does not generate any yaw moments at the yaw bearing. However, it is usually necessary to have at least some yaw damping, in which case there will be a yaw moment at the bearing. In practice, most turbines do use active yaw control. A yaw error signal from the nacelle-mounted wind vane is then used to calculate a demand signal for the yaw actuator. Frequently the demand signal will simply be a command to yaw at a slow fixed rate in one or the other direction. The yaw vane signal must be heavily averaged, especially for upwind turbines where the vane is behind the rotor. Because of the slow response of the yaw control system, a simple dead-band controller is often sufficient. The yaw motor is switched on when the

averaged yaw error exceeds a certain value, and switched off again after a certain time or when the nacelle has moved through a certain angle [15].

Figure 2.16 shows yaw control on small wind turbines.



Figure 2.16: Propeller type wind turbine with tail van for yaw control

2.12 Control System Components

Control of mechanical and electrical processes requires five main functional components (see Figure 2.17) [14]:

1. A process that has a point or points that allow the process to be changed or influenced.
2. Sensors or indicators to communicate the state of the process to the control system.
3. A controller, consisting of hardware or software logic, to determine what control actions should be taken. Controllers may consist of computers, electrical circuits, or mechanical systems.
4. Power amplifiers to provide power for the control action. Typically, power amplifiers are controlled by a low-power input that is used to control power from an external high-power source.
5. Actuators or components for intervening in the process to change the operation of the system.

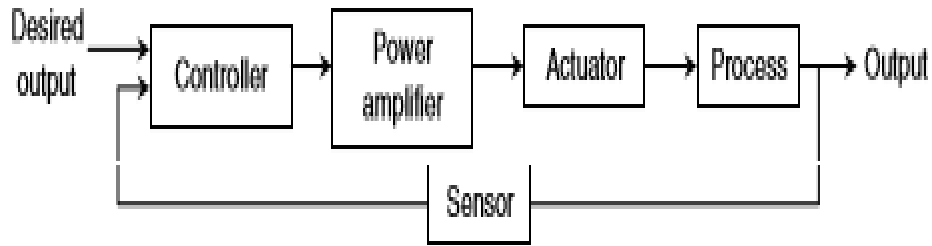

Figure 2.17: Control system components

2.13 Pitch Actuators

An important part of the control system of a pitch-controlled turbine is the pitch actuation system. Both hydraulic and electric actuators are commonly used, each type having its own particular advantages and disadvantages which should be considered at the design stage. Smaller machines often have a single pitch actuator to control all the blades simultaneously, although there is an increasing trend to use individual pitch actuators for each blade on larger turbines [15].

2.14 Basic of Induction and Synchronous Machine

The generation schemes for wind electrical conversion systems depend primarily on the type of output required as well as the mode of operation of the turbine. In present-day practice, two types of generators generally find application in wind power plants: the synchronous generator and the induction generator. Synchronous generators may have dc field excitation or a permanent magnet field. Systems using line-frequency excited alternators and ac commutator generators have been suggested for constant-frequency output from turbine operated in the variable-speed mode, but they are not preferred over synchronous and induction generators [12].

An induction generator or asynchronous generator is a type of alternating current (AC) electrical generator that uses the principles of induction motors to produce power. Induction generators operate by mechanically turning their rotors faster than synchronous speed. A regular AC asynchronous motor

usually can be used as a generator, without any internal modifications. Induction generators are useful in applications such as mini hydro power plants and wind turbines. An induction generator usually draws its excitation power from an electrical grid; sometimes, however, they are self-excited by using phase-correcting capacitors. Because of this, induction generators cannot usually "black start" a de-energized distribution system [17].

Besides being commonly used as drives in the industry, three-phase induction machines have been used as wind generators because of qualities such as ruggedness, reliability, manufacturing simplicity. They constitute the largest segment in the wind power industry today. Two types of three-phase induction machines are used: the squirrel cage type and the wound rotor (slip-ring) type [15].

Asynchronous rotating machines consist of a stator with a preferably three-phase winding, and a rotor carrying either a cage winding or a poly phase coil winding. Normally the stator is the primary member, while the rotor is the secondary member. Induction machine is the term for an asynchronous machine supplied only in the primary part. Cage induction machines prevail in industrial electric drives. Pole pair numbers p of 2, 4, 6 and sometimes 8 are in use, with a preference for $p=2$ due to advantages in manufacturing and specific cost. Wound rotor asynchronous machines feature slip-rings and brushes, allowing to feed the rotor winding. This is the case with the doubly-fed asynchronous machines, often used as WES generators [16].

2.15 PID and PI Controllers

A proportional–integral–derivative controller (PID controller or three term controller) is a control loop feedback mechanism widely used in industrial control systems and a variety of other applications requiring continuously modulated control. A PID controller continuously calculates an error value as the difference between a desired setpoint and a measured process variable and applies a correction based on proportional, integral, and derivative terms

(denoted P, I, and D respectively) which give their name to the controller. The distinguishing feature of the PID controller is the ability to use the three "control terms" of proportional, integral and differential influence on the controller output to apply accurate and optimal control. The Figure (2.18) shows the principles of how these terms are generated and applied [18,19].

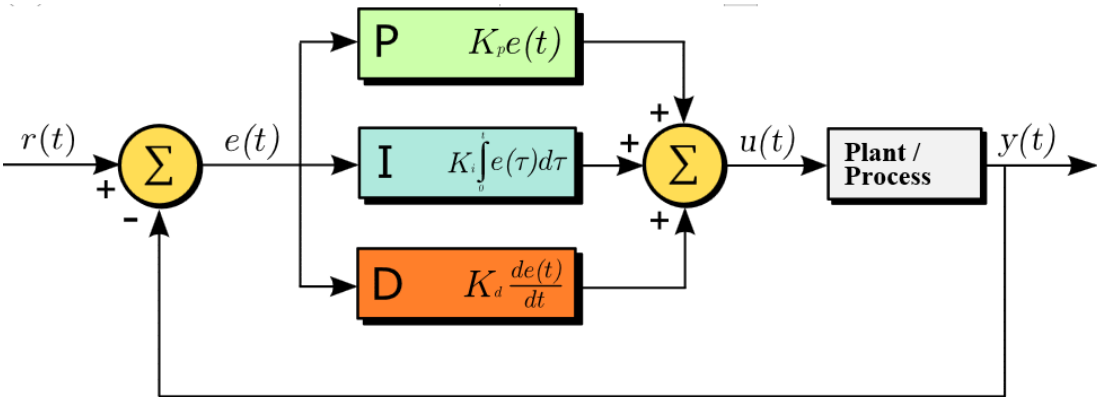

Figure 2.18: Block diagram of PID controller

PID control is often combined with logic, sequential machines, selectors, and simple function blocks to build the complicated automation systems used for energy production, transportation, and manufacturing. Many sophisticated control strategies, such as model predictive control, are also organized hierarchically. PID control is used at the lowest level; the multivariable controller gives the setpoints to the controllers at the lower level. The PID controller can thus be said to be the "bread and butter" of control engineering. It is an important component in every control engineer's toolbox [20].

A differential term is often added, which gives a contribution to the control action proportional to the rate of change of the control error. This is then known as a PID controller. In terms of the Laplace operator s , which can usefully be thought of as a differentiation operator, the PID controller from measured signal x to control signal y can be written as follows [15]:

$$y = \left(K_p + \frac{K_i}{s} + \frac{K_d s}{1+sT_d} \right) x \quad (2.8)$$

Where K_p , K_i , K_d and T_d are the proportional, integral, derivative gains and derivative time respectively.

Setting $K_d = 0$ results in a PI controller.

CHAPTER THREE

MATHEMATICAL MODEL

3.1 Introduction

This chapter discusses the mathematical model of the system which consist of the mathematical model of the wind turbine, induction generator and PI controller. The system components and the benefits of each component were discussed and explained.

3.2 Wind Turbine Model

The power in the wind is proportional to the cube of the wind speed and can be expressed as:

$$P = 0.5\rho Av^3 \quad (3.1)$$

Where ρ is air density ($\rho = 1.225 \text{ kg/m}^3$), A is the area swept by blades and v is wind speed.

A wind turbine can only extract part of the power from the wind, which is limited by the Betz limit (maximum 59%). This fraction is described by the power coefficient of the turbine, which is a function of the blade pitch angle and the tip speed ratio. Therefore, the mechanical power of the wind turbine extracted from the wind is:

$$P_{wt} = 0.5 \rho Av^3 C_p(\beta, \lambda) \quad (3.2)$$

Where C_p is the power coefficient of the wind turbine, β is the blade pitch angle and λ is the tip speed ratio. The value of C_p is highly non-linear and varies with the wind speed, the rotational speed of the turbine, and the turbine blade parameters such as a pitch angle.

Value of the $C_p(\beta, \lambda)$ is calculated as:

$$C_p = 0.5176\left(\frac{116}{\lambda_i} - 0.4\beta - 5\right)e^{\frac{-21}{\lambda_i}} + 0.0068 \lambda \quad (3.3)$$

Where:

$$\frac{1}{\lambda_i} = \frac{1}{\lambda + 0.08 \beta} - \frac{0.035}{\beta^3 + 1} \quad (3.4)$$

The tip speed ratio is defined as the ratio between the blade tip speed and the wind speed:

$$\lambda = \frac{w_{wt} R}{v} \quad (3.5)$$

Where w_{wt} the turbine rotor speed, and R is the radius of the wind turbine blade.

Thus any change in the rotor speed or the wind speed induces a change in the tip speed ratio leading to power coefficient variation.

$$T_m = \frac{P_m}{w} \quad (3.6)$$

Where T_m is the mechanical torque, p_m is the mechanical power.

3.3 Induction Generator Model

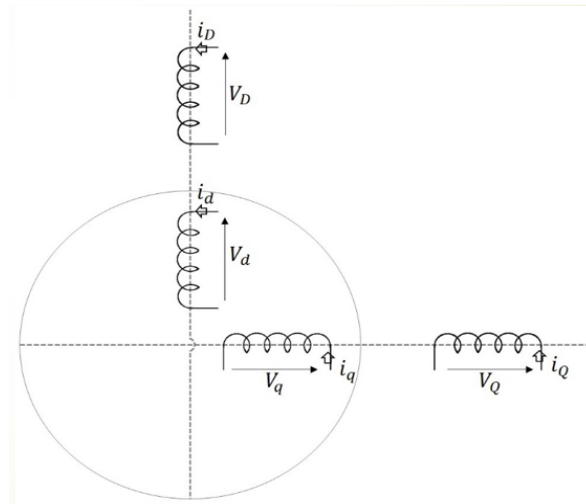

Figure 1.3: Primitive machine

From Figure 1.3:

$$[V] = [Z][I] \quad (3.7)$$

$$[Z] = [R] + [L\rho] + [G]W_r \quad (3.8)$$

The voltages applied to each stator and rotor phases:

$$[V] = \begin{bmatrix} v_D \\ v_Q \\ v_q \\ v_d \end{bmatrix} \quad (3.9)$$

The currents in each stator and rotor phases:

$$[I] = \begin{bmatrix} i_D \\ i_Q \\ i_q \\ i_d \end{bmatrix} \quad (3.10)$$

The resistance, inductance and conductivity matrix are defined as:

$$[R] = \begin{bmatrix} R_D & 0 & 0 & 0 \\ 0 & R_Q & 0 & 0 \\ 0 & 0 & R_q & 0 \\ 0 & 0 & 0 & R_d \end{bmatrix} \quad (3.11)$$

$$[L] = \begin{bmatrix} L_D & 0 & 0 & M_D \\ 0 & L_Q & M_Q & 0 \\ 0 & M_q & L_q & 0 \\ M_d & 0 & 0 & L_d \end{bmatrix} \quad (3.12)$$

$$[G] = \begin{bmatrix} 0 & 0 & 0 & 0 \\ 0 & 0 & 0 & 0 \\ -M_D & 0 & 0 & -L_d \\ 0 & M_Q & L_q & 0 \end{bmatrix} \quad (3.13)$$

The impedance matrix is defined as:

$$[Z] = \begin{bmatrix} R_D + L_D \rho & 0 & 0 & M_D \rho \\ 0 & R_Q + L_Q \rho & M_Q & 0 \\ -M_D W_r & M_Q \rho & R_q + L_q \rho & -L_d W_r \\ M_D & M_Q W_r & L_q W_r & R_d + L_D \rho \end{bmatrix} \quad (3.14)$$

The transformation of the 3-phase induction machine to two phase machine is done by using the phase transformation matrix C1 and commutator transformation C2 as follows:

$$C_1 = \sqrt{\frac{2}{3}} \begin{bmatrix} \frac{1}{\sqrt{2}} & 1 & 0 \\ \frac{1}{\sqrt{2}} & -1 & \frac{\sqrt{3}}{2} \\ \frac{1}{\sqrt{2}} & -1 & -\frac{\sqrt{3}}{2} \end{bmatrix} \quad (3.15)$$

$$C_2 = \begin{bmatrix} \sin \theta & \cos \theta \\ \cos \theta & -\sin \theta \end{bmatrix} \quad (3.16)$$

The new impedance matrix after applied C1:

$$Z' = \begin{bmatrix} R_1 + L_{10}\rho & 0 & M\rho\cos\theta & -M\rho\sin\theta \\ 0 & R_1 + L_{10}\rho & M\rho\sin\theta & M\rho\cos\theta \\ M\rho\cos\theta & M\rho\sin\theta & R_2 + L_{20}\rho & 0 \\ -M\rho\sin\theta & M\rho\cos\theta & 0 & R_2 + L_{20}\rho \end{bmatrix} \quad (3.17)$$

The new impedance matrix after applied C2:

$$Z'' = \begin{bmatrix} R_1 + L_1\rho & 0 & 0 & M\rho \\ 0 & R_1 + L_1\rho & M\rho & 0 \\ -Mw_r & M\rho & R_2 + L_2\rho & -L_2w_r \\ M\rho & Mw_r & L_2w_r & R_2 + L_2\rho \end{bmatrix} \quad (3.18)$$

The voltages and currents equations after transformation when applied C_1 and C_2 :

$$V'' = \begin{bmatrix} V_A \\ V_B \\ V_q \\ V_d \end{bmatrix} \quad (3.19)$$

$$I'' = \begin{bmatrix} I_A \\ I_B \\ I_q \\ I_d \end{bmatrix} \quad (3.20)$$

3.4 PI Controller Model

The transfer function of PI controller is:

$$G(s) = \left(K_p + \frac{K_i}{s} \right) \quad (3.21)$$

Where K_p and K_i are the proportional and integral gains and respectively.

3.5 Model Components

The main components of this model are:

3.5.1 Wind turbine

It convert the wind's kinetic energy to the torque applied to the generator shaft.

It consist of three input and one output. The three inputs are the generator speed (ω_r_PU) in PU of the nominal speed of the generator, the pitch angle in degrees and the wind speed in m/s. The output is the torque applied to the generator shaft.

3.5.2 Asynchronous machine

The input of the block is the mechanical torque at the machine's shaft. When the input is a positive the asynchronous machine behaves as a motor. When the input is a negative signal, the asynchronous machine behaves as a generator.

A, B, C are the terminal of the asynchronous machine. The Simulink output of the block is a vector containing measurement signals.

3.5.3 Three-phase series C load

It act as capacitor. It used to improve the voltage stability.

3.5.4 Transformer

Transformers are used to increase (or step-up) voltage before transmitting electrical energy over long distances through wires. Wires have resistance which loses energy through joule heating at a rate corresponding to square of the current. By transforming power to a higher voltage transformers enable economical transmission of power and distribution.

3.5.5 PI controller

It used to control the pitch angle. The input of the block is typically an error signal, which is the difference between a reference signal and the system output.

3.5.6 Three-phase programmable voltage source

It act as grid that wind turbine connected to it.

3.5.7 Three-phase V-I measurement

The Three-Phase V-I Measurement block is used to measure instantaneous three-phase voltages and currents in a circuit.

3.5.8 Power block

It used to compute three-phase active and reactive powers using three-phase voltage and current phasors.

3.5.9 Scope

This model consist of several scopes to display signals generated during simulation.

Figure 3.2 shows the model of the system.

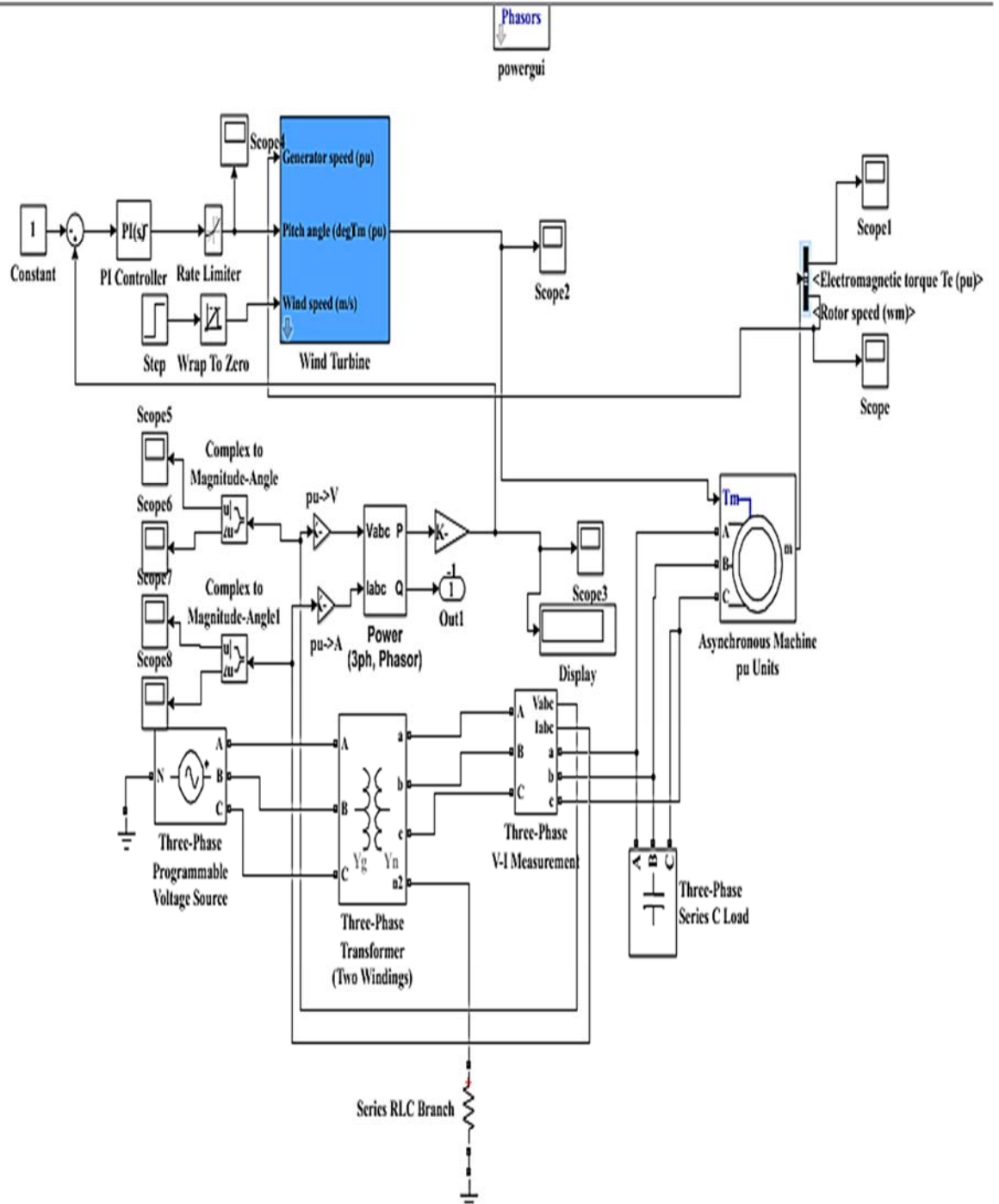

Figure 3.2: Model of the system

CHAPTER FOUR

RESULTS AND DISCUSSIONS

4.1 Introduction

This chapter presents the results of pitch control for wind turbine by using PI controller. The Matlab/Simulink is used to get the results. The results contain the effect of the pitch control on mechanical torque of wind turbine, rotor speed, power, current and voltage. It used different values of wind speed to get the results.

4.2 Results at Wind Speed 14 m/s

When it applied 14 m/s wind speed to the model. The power at the beginning is above rated value until 5 second because the pitch angle is zero. When the PI controller is activated the pitch angle is increase that makes power reduce and pitch angle still increase until power equal rated value. Figure 4.1 shows the effect of changing the pitch angle on power.

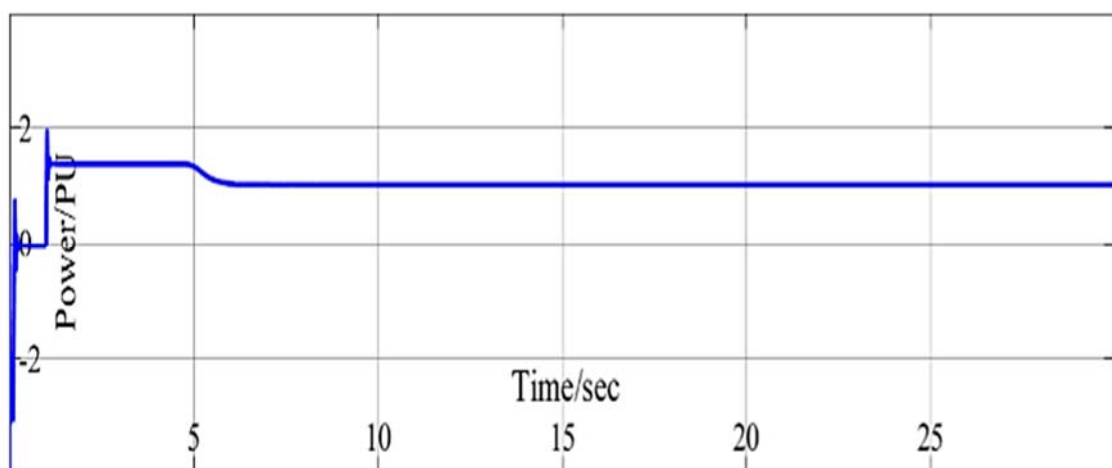

Figure 4.1: Change in power at 14m/s

Figure 4.2 shows pitch angle. At the beginning the pitch angle is zero to get maximum value of C_p or power. When power exceeds the rated value pitch angle increase until power equal rated value.

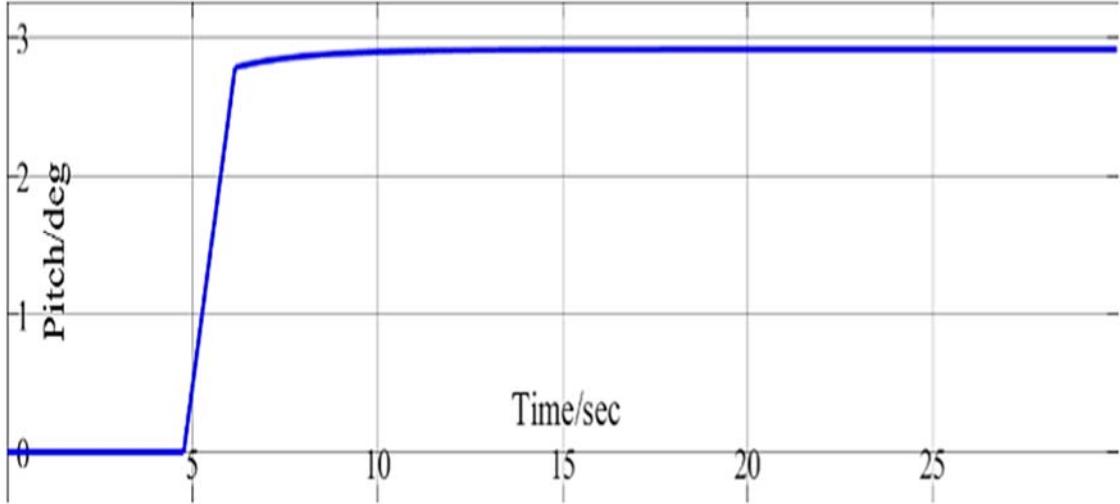

Figure 4.2: Change in pitch angle at 14 m/s

Figure 4.3 shows changing of mechanical torque depending on pitch angle. When pitch angle is zero the mechanical torque is high. When pitch angle increase the torque is reduced to be a constant value.

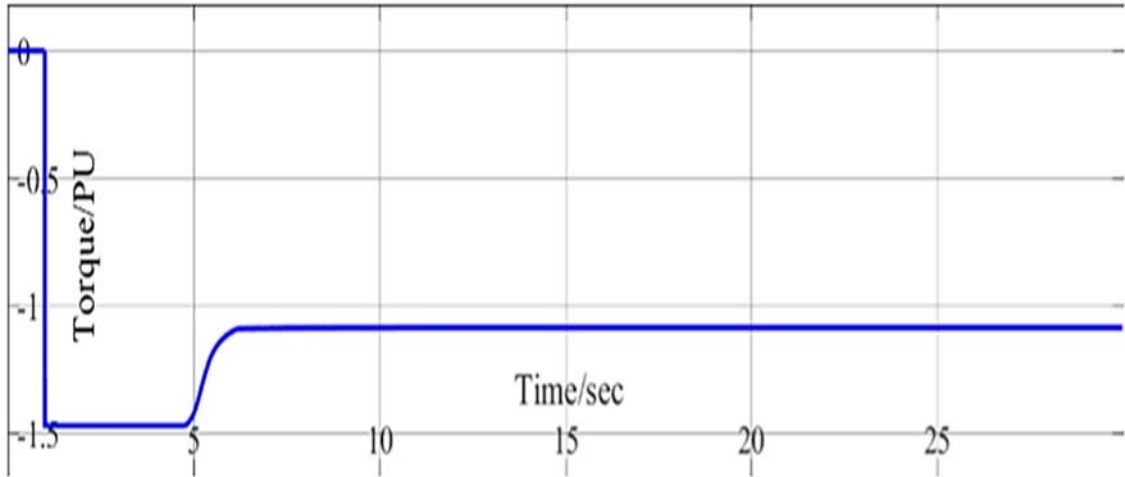

Figure 4.3: Change in mechanical torque at 14 m/s

Figure 4.4 represents changing of rotor speed depending on the change of pitch angle. When pitch angle is zero the rotor speed is above rated value. When the

pitch angle increased the rotor speed reduced and still reducing until equal rated value.

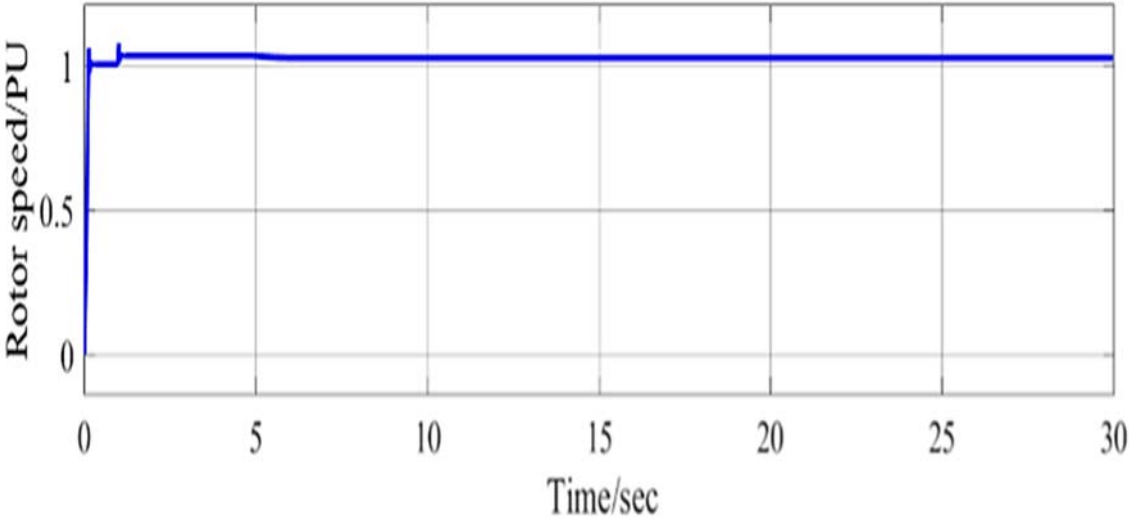

Figure 4.4: Change in rotor speed at 14 m/s

Figure 4.5 represents changing of voltage depending on pitch angle. The value of voltage is almost constant. Because power electronics used in wind turbine system to get constant voltage and frequency.

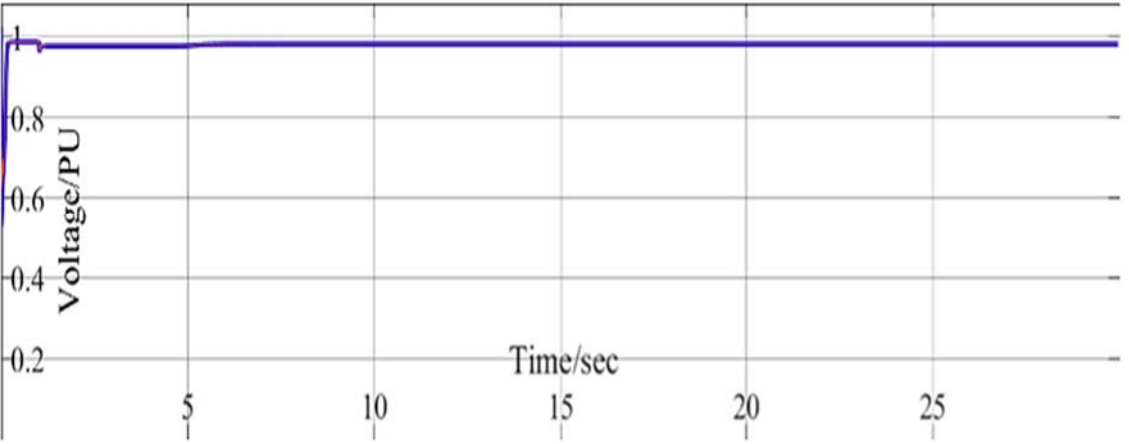

Figure 4.5: Change in voltage at 14m/s

Figure 4.6 shows changing in current depending on pitch angle. When pitch angle is zero the current is above rated value. When the pitch angle increases the current reduce because the power is also reduced. Current still reducing until equal rated value.

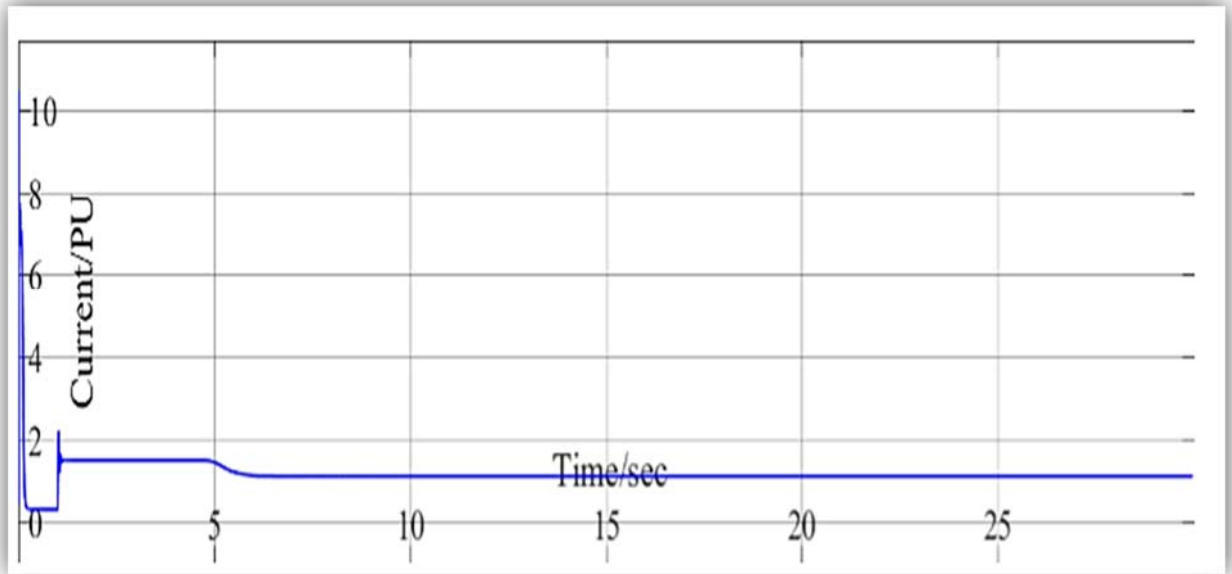

Figure 4.6: Change in current at 14m/s

4.3 Results at Wind Speed 16 m/s

At wind speed equal 16 m/s the PI controller takes more time than 14m/s to adjust the pitch angle because the power at 16 m/s is greater.

Figure 4.7 shows changing of pitch angle depending on PI controller. First pitch angle is zero to get maximum power. Secondly the pitch angle increased to reduce power to be constant value that makes rated value of power.

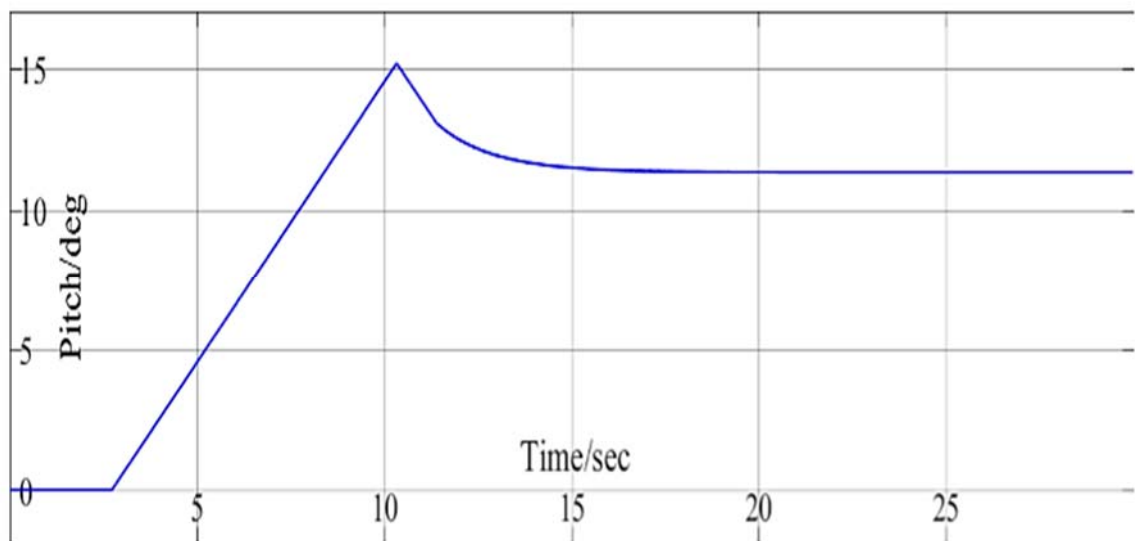

Figure 4.7: Change in pitch angle at 16m/s

Figure 4.8 represents changing in power depending on pitch angle. Initially the power is greater than the rated value. When the PI controller activated the power decrease until the pitch angle be constant value to make the power equal rated value.

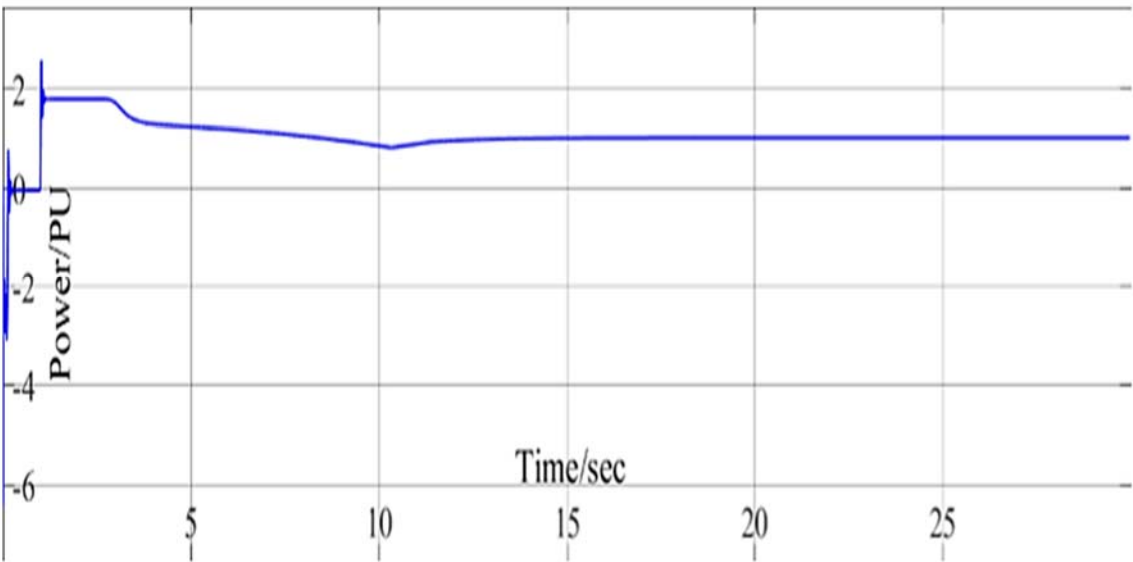

Figure 4.8: Change in power at 16m/s

Figure 4.9 explain changes in mechanical torque of wind turbine depending on pitch angle. At the beginning the mechanical torque is high. When the pitch angle increased the mechanical torque is decreased to be a constant value.

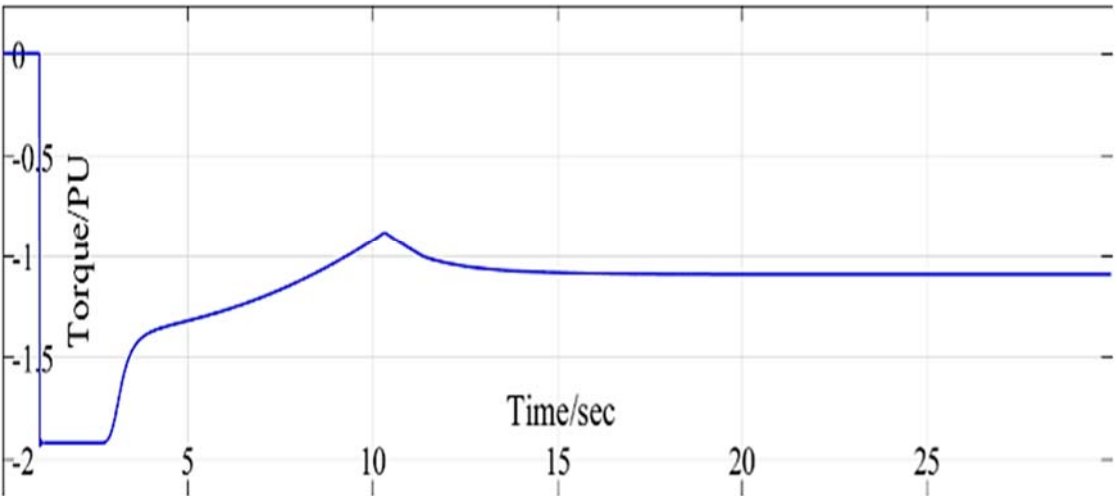

Figure 4.9: Change in mechanical torque

Figure 4.10 shows changing in rotor speed depending on the pitch angle. First the rotor speed is above rated value. Secondly the rotor speed decrease when pitch angle increase and still decrease until be rated value.

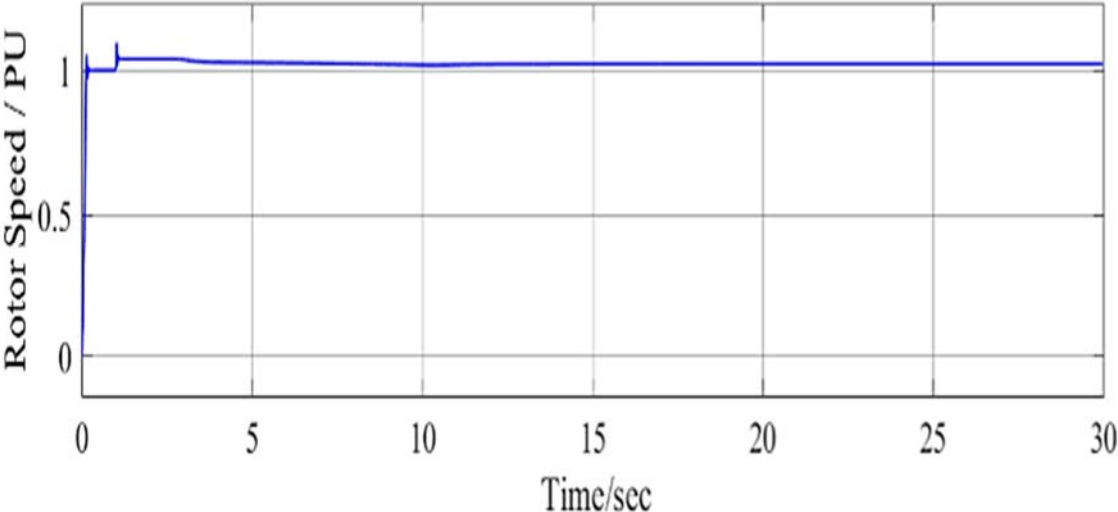

Figure 4.10: Change in rotor speed at 16m/s

Figure 4.11 represents changing in voltage depending on the pitch angle. The voltage is constant and the voltage didn't be affect by pitch angle.

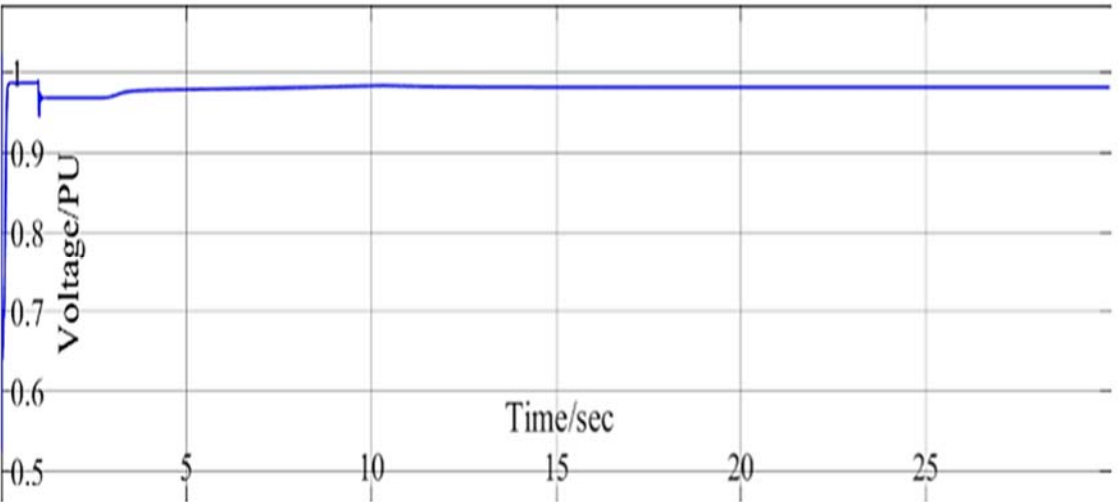

Figure 4.11: Change in voltage at 16m/s

Figure 4.12 explain changes in current depending on pitch angle. At the beginning the current is too high, when pitch angle increased the current decreased until equal constant value.

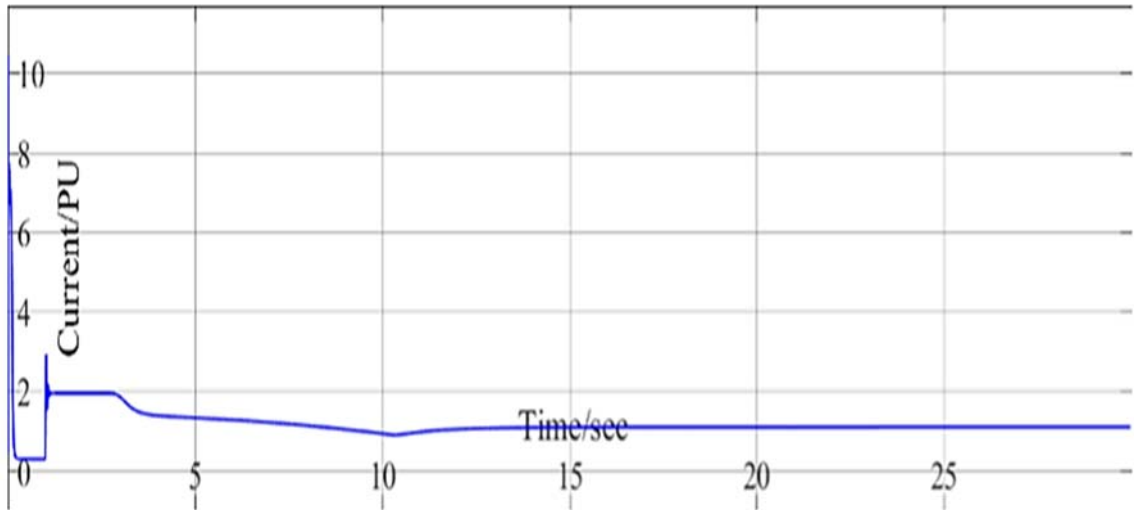

Figure 4.12: Change in current at 16m/s

4.4 Results at Wind Speed 18 m/s or Above

The cutoff speed of this turbine is started from 18m/s to protect turbine from damage and burning. Figure 4.13 shows changing in mechanical torque. The mechanical torque is zero at these speed of wind.

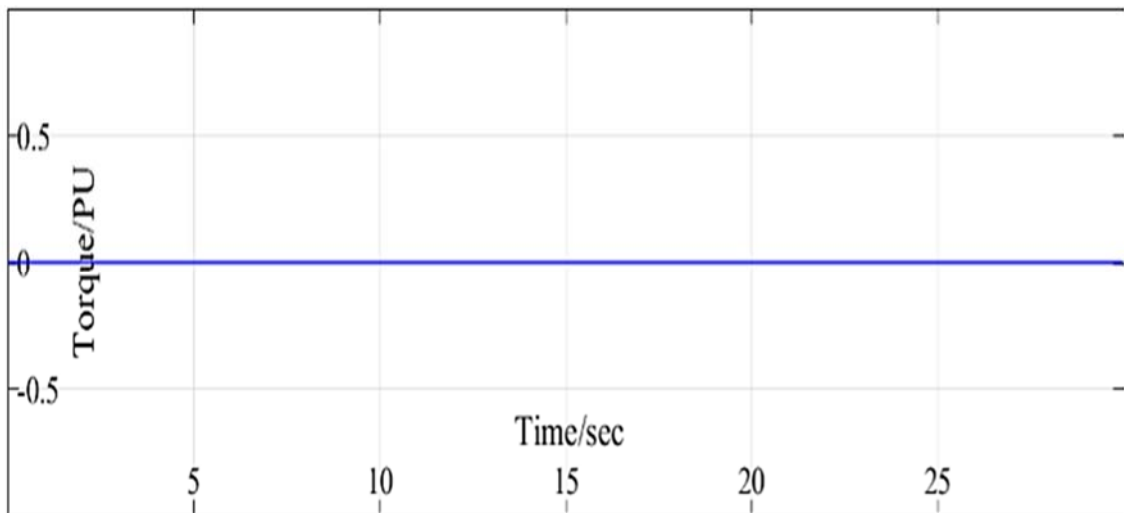

Figure 4.13: Change in mechanical torque at 18m/s or above

Figure 4.14 shows changing in power. The power also be zero at these speed of wind.

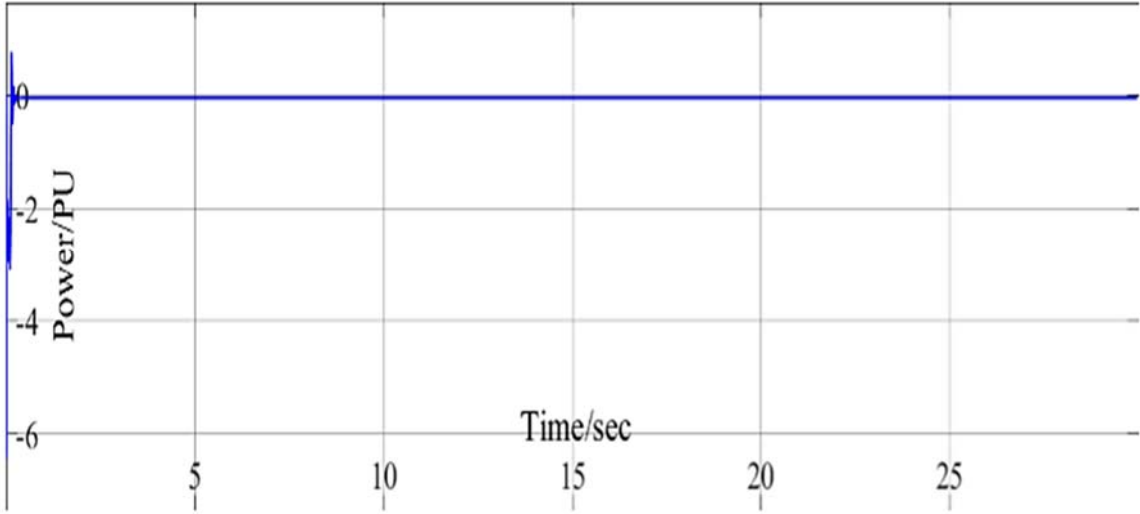

Figure 4.14: Change in power at 18m/s or above

CHAPTER FIVE

CONCLUSION AND RECOMMENDATIONS

5.1 Conclusion

One of the most important problems facing the world today is an energy problem. The main sources of the fossil fuel are expected to end up. Therefore, renewable energy (wind, sunlight) must be used instead of the fossil fuel.

Pitch control is very important for a wind turbine for the maximum benefit of wind energy at different speed of wind. Pitch control applied to wind turbine and its use PI controller to control of pitch angle. The Matlab/ Simulink used to simulate the system.

From the simulation result the maximum power extracted from wind turbine at low wind speed, power kept constant at high wind speed above rated wind speed and wind turbine stopped at higher wind speed to avoid damage and burning of wind turbine to minimize cost of maintenance.

Finally the effect of the pitch control on mechanical torque of wind turbine, rotor speed, power, current and voltage were discussed.

5.2 Recommendations

- Use other methods of controller for example fuzzy logic control.
- Do this project practically.

REFERENCES

- [1] Djamila Rekioua, “Wind Power Electric Systems”, Springer-Verlag, London, 2014.
- [2] Zhao Ximei, Sun Xianfeng, “Individual Variable Pitch Control of Wind Turbines”, Shenyang University of technology, china, 2011.
- [3] Nagai, Baku, Ameku, Kazumasa, Roy, Jitendro Nath, “Performance of a 3 kW wind turbine generator with variable pitch control system”, Japan Society, Japan, 2009.
- [4] Johnson, K.E, “Adaptive pitch control of variable-speed wind turbines”, Journal of Solar Energy Engineering, USA, 2008.
- [5] Price, Trevor J, “James Blyth – Britain's First Modern Wind Power Engineer”, University of Glamorgan, Wales, 2005.
- [6] Eilperin, Juliet, Steven Mufson, “ Renewable Energy’s Environmental Paradox”, The Washington Post, USA, 2009.
- [7] Hamilton, Tyler, “ Wind Gets Clean Bill of Health”, Toronto Star , Toronto, 2009.
- [8] Dolf Gielen, “Renewable energy technology: cost analysis series”, IRENA, European union, 2012.
- [9] Henriik Lund, “Large-Scale integration of wind power into different energy system”, Aalborg University, Denmark, 2004.
- [10] Josepha Sherman, “Wind Power”, Capstone Press, USA, 2004.
- [11] Charles H.Eccleston, Frederic March, Timothy Cohen, “Inside Energy”, Taylor, Francis Group, LLC, USA, 2012.
- [12] S.N.Bhadra, D.Kastha, S.Banerjee, “Wind Electrical Systems”, Oxford University, India, 2005.

- [13] Muiyiwa Adaramola, “Wind Turbine Technology”, Apple Academic, USA, 2014.
- [14] J.F.Manwell, J.G.McGowan. A.L.Rogers, “Wind Energy Explained”, John Wiley & Sons Ltd, UK, 2009.
- [15] Tony Burton, Nick Jenkins, David Sharpe, Ervin Bossanyi, “Wind Energy Handbook”, John Wiley & Sons Ltd, UK, 2011.
- [16] Prof.Dr.Manfred Stiebler, “wind energy system for electric Power Generation”, Springer-Verlag Berlin Heidelberg, Germany, 2008.
- [17] Theodore Wildi, Prentice Hall, “Electrical Machines Drives and Power Systems”, Pearson Education Limited, USA, 2013.
- [18] Katshuhiko Ogata, “Modern Control Engineering”, Pearson Education, USA, 2010.
- [19] Aidan O’Dwyer, “Handbook of PI and PID Controller Tuning Rules”, Imperial College Press, London, 2009.
- [20] Karl J.Astrom, Tore Hagglund, “PID Controllers Theory Design and Tuning”, Instrument Society of America, USA, 1995.

APPENDIX

Appendix shows the data of model.

Generator data	
Nominal power	4.7KW
Line to line volt	460V rms value
Frequency	60 HZ
Stator resistance	0.0397p.u
Rotor resistance	0.01909p.u
Inductance resistance	0.0397p.u
Magnetizing Inductance	1.354p.u
Inertia	0.0952s
Friction factor	0.05479p.u
Pairs' of poles	2
Excitation reactive power	2KVAR
Turbine data	
Nominal mechanical output power	4.7KW
Base wind speed	12m/s
Maximum power at based wind	1p.u
Reference pitch angle	0
PI parameter	
K _p	1
K _i	15
Transformer parameter	
Nominal power	4.7KW
Frequency	60Hz
Winding 1 voltage	25KV rms value
Winding 1 resistance	0.025/30 PU
Winding 1 inductance	0.025 PU

Winding 1 voltage	460V rms value
Winding 2 resistance	0.025/30 PU
Winding 2 inductance	0.025 PU
Magnetization resistance	500 PU
Magnetization inductance	Inf