

# CHAPTER ONE

## INTRODUCTION

### 1.1 Overview

Large centralized building computerized control systems first appeared in the 1960s. These evolved from industrial process control systems into mini-computer-controlled systems deployed in the late 1960s. Initially, they appeared in only the largest new buildings where the first cost of the system could be broadly amortized and reductions realized in buildings operation and maintenance staff.

However, developments in computer and communication technologies in recent years have led to the evolution of these systems to be used in the management of the building for the benefit of increasing the adequacy of electric power and reduce consumption, and others, and reduce the cost of investment buildings and complexes. It was called on these systems have different names, but it finally agreed to call building management system.

Internet of Things (IOT) is an advanced automation and analytics system which exploits networking, sensing, big data, and artificial intelligence technology to deliver complete systems for a product or service.

### 1.2 Research Problem

Support Building Management System with its current components does not remote control over the Internet.

Because the world was beginning to connect everything to the Internet, it was necessary to have a technology that allowed the system to be monitored and controlled by the Internet.

### **1.3 Research Objectives**

-The internet of things (IOT) software programming is a good tool using to develop the buildings management system.

System simulation using Arduino Uno and sensors and Ethernet shield to simulate system

### **1.4 Methodology**

- A simulating system of BMS using the protues software simulation.
- Modeling overall system using Arduino Uno unit as a controller.
- System monitoring and control using IOT technology.

### **1.5 Research Layout**

This is research consists of an abstract and five chapters:

-chapter one deals with an introduction, overview, research problem, research objectives, methodology and research layout.

-chapter two is about BMS concept that consists of introduction about BMS and its hardware.

-chapter three illustrates IOT technology consisting of introduction,IOT features,IOT advantages,IOT hardware,IOT technology and protocol, and IOT applications, challenges face s IOT technology.

-chapter four deals with system components, system simulation and practical model of the system

-chapter five consists of the conclusion of the research and recommendations.

# CHAPTER TWO

## BUILDING MANAGEMENT SYSTEM

### CONCEPT

#### 2.1 Introduction

The BMS concept emerged in the early 1950s and has since changed dramatically both in scope and system configuration. System communications evolved from hardwired to multiplexed to today's two-wire all digital system [1].

A building management system (BMS) is a control system that can be used to monitoring and manage the mechanical, electrical and electromechanical service in a facility .Such service can include power, heating, ventilation, air condition, physical access control, pumping stations, elevators and lights

Building management systems are most commonly implemented in large projects with extensive mechanical, HVAC, and electrical systems. Systems linked to a BMS typically represent 40% of a building's energy usage; if lighting is included, this number approaches to 70%. BMS systems are a critical component to managing energy demand. Improperly configured BMS systems are believed to account for 20% of building energy usage, or approximately 8% of total energy usage in the United States [2][3].

#### - **Function of BMS:**

Management system to provide services , but also integrated with systems management administrative systems, and uses the term facilities management of the systems that occupy the buildings and run by using computer-aided control .

Falls with in the mission critical system control and building automation :

- Monitor all equipment service in the building.
- Control and access to the best run.
- Registration requirements of consumption and presented in the statistics , generate reports printed journal describes the condition of the building shown by all indicators management of the building.
- show the status of the system and errors that occur in the control center , the coordination between all systems work in disaster situations to achieve living out in a good manner and ensure their safety.
- The system also made a statement on the locations of fire screens and modules manifesting computer or on plates illustrative , especially referring to the shortest path and the best and safe access to the area of the fire , which helps fire fighters and residents .
- buliding magement system providing centralized control of all parts in the case of normal work and at the time of errors and malfunctions.

**- Benefits of BMS:**

BMS has many benefits belong to the building and to the owner.

The building tenants:

- Good control of internal comfort conditions.
- Possibility of individual room control.
- Effective monitoring and targeting of energy consumption.
- Effective response to [HVAC](#)-related complaint.
- Save time and money during the maintenance.

For building owner

- Higher rental value.
- Flexibility on change of building use.
- Individual tenant billing for services facilities manager.

## **2.2 BMS Hardware**

Most of the BMS consist of the following:

- Lighting
- HVAC
- Elevator
- Firefighting system

### **2.2.1 Lighting**

Lighting has become the focus of attention today as the high proportion of consumption energy may exceed 50% of the total consumption for that day being on the development of lighting products in order to improve their properties and to achieve savings in consumption , which would enormous sums for the benefit of the national economy.

No single lighting system can be said to be the only choice in a given instance, on the contrary,the designer normally has a choice of at least two systems that, if utilized properly, yield illumination of adequate quantity and good quality. However,other factors, such as harmonization with the architecture and economics, usually tip the balancein favour of one or the other[4].

The five generic types of lighting systems are:

- Indirect.

-Semi-indirect.

-Diffuse or direct-indirect.

-Semi-direct.

-Direct.

### **- Indirect lighting**

Between 90% and 100% of the light output of the luminaires is directed to the ceiling and upper walls of the room. The system is called indirect because practically all the light reaches the horizontal working plane indirectly, that is via reflection from the ceiling and upper walls.

### **- Semi-indirect lighting**

Between 60% and 90% of the light is directed upward to the ceiling and upper walls. This distribution is similar to that of indirect lighting, except that it is somewhat more efficient and allows higher levels of illumination without undesirable brightness contrast between the luminaire and its background, along with lower ceiling brightness.

### **- Diffuse direct-indirect lighting**

Direct-indirect lighting provides an approximately equal distribution of light upward and downward, resulting in a bright ceiling and upper wall. For this reason, luminance ratios in the upper-vision zone are usually not a problem.

### **- Semi-direct lighting**

With this type of lighting system, 60% to 90% of the luminaire output is directed downward, and the remaining upward component serves to illuminate the ceiling.

## **- Direct lighting**

In this system essentially all the light is directed downward. As a result, ceiling illumination is entirely due to light reflected from floor and room furnishings. This system, then, more than any other, requires a light, high-reflectance, diffuse floor unless a dark ceiling is desired from an architectural or decorative view point.

### **Rationalization of energy consumption for lighting :**

To reduce the energy consumption should be implemented the following procedures:

#### **-First procedure**

To take advantage of natural lighting and installing window blinds to light from the outer surface while the reflective light from the inner surface , and this procedure will result in the day to enter the amount of lumens from abroad.

#### **-Second procedure**

Measuring lumen often are not installing lighting in a scientific capacities and are often in excess of the required.

#### **-Third procedure**

Plating the walls and ceilings in light colors , preferably white , bringing the reflection coefficient up to 90 %.

#### **-Four procedure**

Installation of the sensors to provide various types of waste delicate movement of people can be used in places that are not occupied by man for long periods , for example, in the long hallways in large buildings and large halls and in the bathrooms of public places.

#### **-Fifth procedure**

Replace regular light bulbs with an other energy-saving.

## **2.2.2 Heating Ventilating Air Conditioning**

HVAC refers to technology of indoor or automotive environmental comfort. HVAC system design is a major sub discipline of mechanical engineering, based on the principles of thermodynamics, fluid mechanics, and heat transfer. HVAC is important in the design of medium to large industrial and office buildings such as sky scrapers and in marine environments such as aquariums, where safe and healthy building conditions are regulated with temperature and humidity, as well as "fresh air" from outdoors.

In modern buildings the design, installation, and control systems of these functions are integrated into one or more HVAC systems. For very small buildings, contractors normally estimate the capacity, engineer, and select HVAC systems and equipment. For larger buildings, building service designers, mechanical engineers, or building services engineers analyze, design, and specify the HVAC systems. Specialty mechanical contractors then fabricate and commission the systems. Building permits and code-compliance inspections of the installations are normally required for all sizes of buildings[5].

The HVAC system can be represented in Figure 2:1



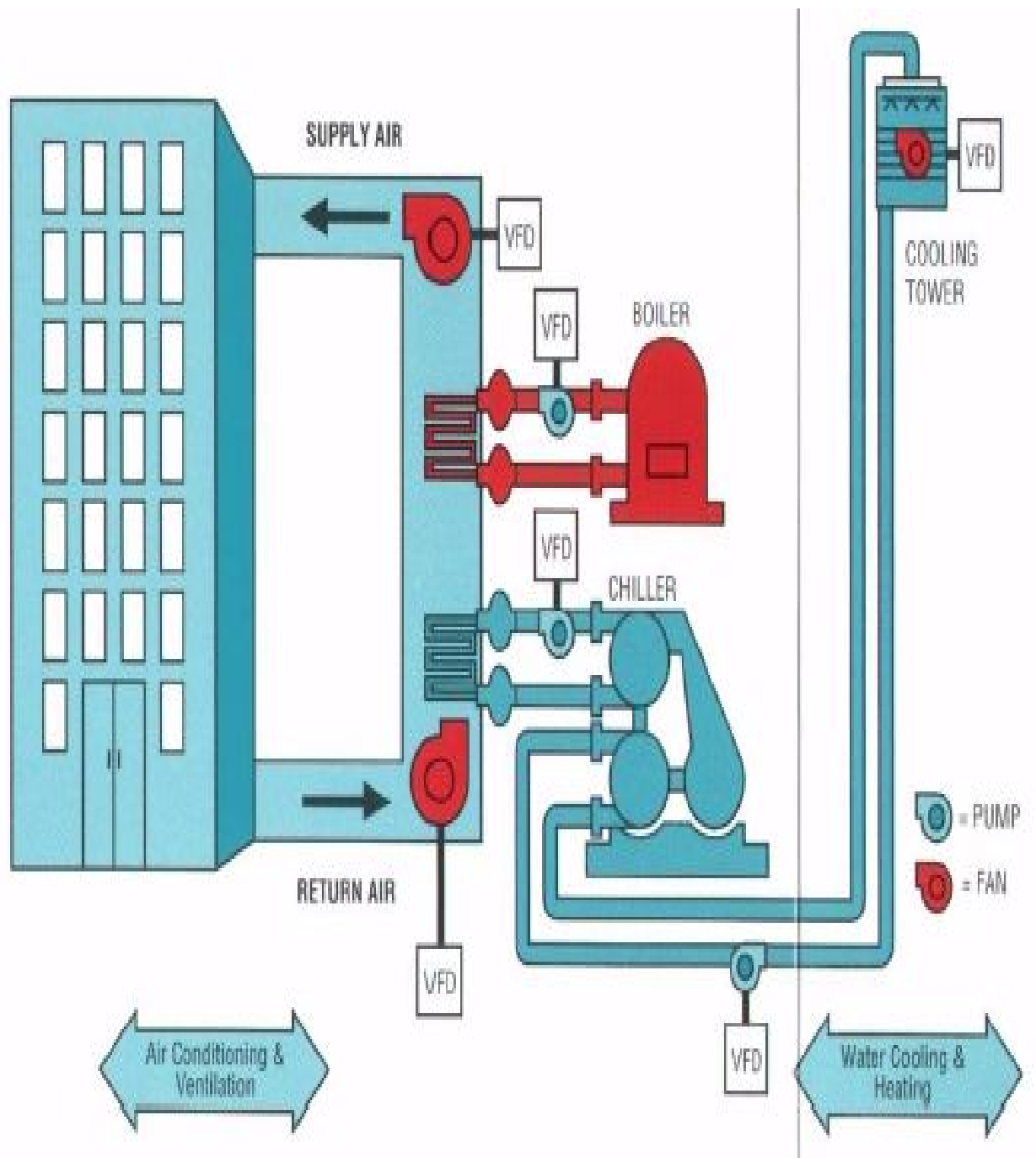

Figure 2.1: HVAC system

**-Heating:**

A heater is an object that emits heat or causes an other body to achieve a higher temperature. In a household or domestic setting, heaters are usually appliances whose purpose is to generate heat (i.e. warmth) for the building.

Other types of heaters are ovens and Furnaces. Heaters exist for all states of matter, including solids, liquids, and gases. Heat can be transferred by convection, conduction, and radiation. The opposite of a heater (for warmth) is an air cooler (for cold) used to lower the ambient temperature[5].

**-Ventilating:**

Ventilation is the process of changing or replacing air in any space to control temperature or remove any combination of moisture, smoke, heat, dust, air borne bacteria, or carbon dioxide, and to replenish oxygen. Ventilation includes both the exchange of air with the outside as well as circulation of air with in the building. It is one of the most important factors for maintaining acceptable indoor air quality in buildings[5].

**-Air conditioning:**

An air conditioning system, or a stand alone air conditioner, provides cooling and humidity control for all or part of a building. Air conditioned buildings often have sealed windows, because open windows would work against the system intended to maintain constant indoor air conditions.

Outside, fresh air is generally drawn into the system by a vent into the indoor heat exchanger section, creating positive air pressure. The percentage of return air made up of fresh air can usually be manipulated by adjusting the opening of this vent. Typical fresh air in take is about 10% .Air conditioning and refrigeration are provided through the removal of heat. Heat can be

removed through radiation, convection, or conduction.

Refrigeration conduction media such as water, air, ice, and chemicals are referred to as refrigerants. A refrigerant is employed either in a heat pump system in which a compressor is used to drive thermodynamic refrigeration cycle, or in a free cooling system which uses pumps to circulate a cool refrigerant (typically water or a glycol mix)[5].

The HVAC system contains:

-Chillers.

-Pumps

-Pipes.

-Boilers

-Cooling towers.

- Air Handling Units.

**-Chillers:**

A chiller is a machine that removes heat from a liquid via a vapor-compression or absorption refrigeration cycle. This liquid can then be circulated through a heat exchanger to cool air or equipment as required[1].

**-Pumps:**

The hydraulic machine is to provide energy to a liquid or gas as it passes through them; leading to raise the pressure of a fluid or gas or increasing its speed or lifting fluid from a certain level to an other level higher than.

Type of pumps:

-Main pump

-Auxiliary

Type of pipes:

-Hot water pipe.

-Cold water pipe

**-Cooling towers:**

Cooling towers are heat removal devices used to transfer process waste heat to the atmosphere. Cooling towers may either use the evaporation of water to remove process heat and cool the working fluid to near the wet-bulb air temperature or in the case of "Close Circuit Dry Cooling Towers" rely solely on air to cool the working fluid to near the dry-bulb air temperature. Common applications include cooling the circulating water used in oil refineries, chemical plants, power stations and building cooling.

**-Central heating system(boilers):**

A heating system is a mechanism for maintaining temperatures at an acceptable level; by using thermal energy with in a home, office, or other dwelling. Often part of an HVAC system. A heating system may be centralized or distributed[1].

**-Air Handling Units (AHU):**

An air handler, or air handling unit (often abbreviated to AHU), is a device used to condition and circulate air as part of a heating, ventilating, and air-conditioning (HVAC) system. An air handler is usually a large metal box containing a blower, heating or cooling elements, filter racks or chambers, sound attenuators, and dampers. Air handlers usually connect to ductwork that distributes the conditioned air through the building and returns it to the AHU.

### 2.2.3 Elevator

Car words of hanging ropes hanging from steel pulley connected to an electric motor rotates jagged.

The Types of elevators are:

- Lifts a tight rope ( cable system ).
- Hydraulic lifts.
- Lifts at tight rope

Car consists of ropes and steel rods and control equipment and install columns and an electric motor.

The design of each component is as follows :

- The motor must be works on the current variable type is specially manufactured with melvin drag lifts start small stream and high strength (high start in torque).

The speeds are controlled by speed regulator works to accelerate the speed of movement. Maximum at the beginning of the movement and at a certain distance from the stop point is to change. Minor speed so that it is convenient to stop by electromechanical brake .And the power of 7.5 HP motor and has a fan for cooling.

- Car be manufactured specifically to fit in with the power of the motor and the factory of stainless sheet. Steel and consists of the car ( the installation window and the base and the walls and ceiling ).Manufactured according to the specifications or equivalent.

The operation panel Car and contains:

Push button number of floors.

Touch of alarm .

Touch of the fan .

Touch of opening the door .

Indicator floor.

-Control System Down Collection Motion Control:

Computer (Microprocessor) in the machinery room . Handles the elevator with each call only if it is in the case of the rise .

The Railway Installation Guide Rails are made of iron and installed on the walls of the skylight and containing protrusions and pits Tongue & Grooves to control the functioning of the vehicle.

- Hydraulic lifts:

Operating system, hydraulic lifts to raise the cabin using a hydraulic arm (a hydraulic piston located with in the cylinder ) , and summed up the idea or principle in action.

Cylinder containing a piston hydraulic delivers reservoir fluid is compressible this liquid transfer pressure from the hydraulic pump and converted to force you to pay the piston from its base , making the cabin related ascend to the top , and in the event of a landing there are valve electromagnetic allow the return of the liquid compressed under the piston of the tank in the opposite direction .

During the ascent .Up on arrival cab for the role required the sensor located in that role gives a signal to the pump to stop.During the process of landing. When accessing the desired role of the cab , the sensor is located in that role gives a signal to the valve closure . In the event of pump action , the valve remains closed, and this is obvious to make all the liquid tends to raise the piston , in the case of open the valve , the pump stop working .

The Control system in the elevators:

In general, the computer is the key element in the control system to operate the elevators. Many of the modern elevators under the control of the computer and that computer work is to address all the relevant information and the development of the elevator and the elevator car where:

- The passenger wants to go.
- The place of each floor.
- To place a vehicle lift.

Knowing the place where passengers is very easy because the buttons in the car elevator and the buttons on each floor are present in the computer and when you press one of these buttons the computer logs the request and there are many ways to discover the place of a vehicle elevator in the system is common there is a sense of sensor to read the series of holes on a long vertical bar is located on the column, and also there is another way to see the place where the vehicle elevator movement to change the engine computer car gradually to reach every floor and believe in this quiet ascent to the elevator for passengers[6].

#### **2.2.4 Firefighting System**

Is the act of extinguishing fires. A fire\_fighter fights fires to prevent loss of life, and destruction of property and the environment. Fire fighting is a highly technical skill that requires professionals who have spent years training in both general fire fighting techniques and specialized areas of expertise[7].

Divided into two parts:

- Manual
- Auto
- Manual fire fighting system

-Extinguisher

Table 2.1: Type and class of use egtinguisher

Class	Type of fire	Extinguisher
A	Woods, papers, plastics	Water
B	Oils, liquids, paints	Gas
C	Electrical devices	Foam
D	Industry	Powder
E	kitchen	Special

- Auto fire fighting system

Gas suppression systems operate in a similar manner to high pressure water mist systems. A gas is stored in canisters at high pressure with pipe work to distribute the gas around the premises. In the event of a fire, this gas is dispersed wherever required in just a few seconds.

Types of gas suppression systems are :

- Chemical or Synthetic Gas Fire Suppression
- CO2 Systems
- Chemical or synthetic gas fire suppression

There are a number of key benefits from using these systems:

-Non-conductive – they can be used safely on electrical fires in locations such as server rooms and data suites

-Space saving – they require only small quantities of the gas or chemical,



storage cylinders occupy minimal space compared to water tanks etc.

#### - CO2 Systems

Carbon dioxide is a highly efficient fire suppressant. When a fire occurs, a CO2 system will deliver a blanket of gas that quickly reduces the amount of oxygen to levels where combustion can no longer continue.

#### -Fire safety

One of the most important regulations that must be met in the buildings, which helps the safety of people's lives.

The fire evacuation plan are:

- Hearing the fire alarm stop work immediately.
- Follow evacuation route and precede the designated assembly area.
- Use exit staircases.
- Don't use lift.

The fire safety systems are:

- Emergency exit
- Emergency light
- Emergency sign
- Assembly point

All of these devices is one of the devices low current .

#### - Fire alarm system:

A system resulting from the study site as a whole and determine the quality of different devices for the detection of the fire areas and distribution processes and then determine the appropriate control of the site and method of inter dependence with each other to get Integrated system.

The Target are:

- Fire detection and location.
- Alert building occupants in the event of a fire to enable them to escape.
- Fire-fighting in the first stages.
- Report the nearest fire station.
- Fire alarms and detectors :

The fire alarms used to alert people in the building that small fire or some overheating has occurred that means there is a danger.

-Smoke detectors : the main distance between two detectors are 7.5cm.

-Heat detectors : the main distance between two detectors are 3.5cm.

-Detectors work :

In the absence of smoke is easily pass electric current in the detector does not hinder the work of the Detector .As in the case of the presence of smoke when the smoke billowing smoke cut the pass age of electric current which is suffering from a source of radio active particles and sends a signal to the control panel in a fire alarm and start the sirens and automatically be contacted by men fire[7].

# CHAPTER THREE

## INTERNET OF THINGS (IOT) FUNDAMENTAL

### 3.1 Introduction

The Internet of Things (IOT) is an important topic in technology industry, policy, and engineering circles and has become headline news in both the specialty press and the popular media. This technology is embodied in a wide spectrum of networked products, systems, and sensors, which take advantage of advancements in computing power, electronics miniaturization, and network interconnections to offer new capabilities not previously possible[8].

The term “Internet of Things” was first used in 1999 by British technology pioneer Kevin Ashton to describe a system in which objects in the physical world could be connected to the Internet by sensors. Ashton coined the term to illustrate the power of connecting Radio-Frequency Identification (RFID) used in corporate supply chains to the Internet in order to count and track goods without the need for human intervention. Today, the Internet of Things has become a popular term for describing scenarios in which Internet connectivity an

d computing capability extend to a variety of objects, devices, sensors, and everyday items[8].

While the term (IOT) is relatively new, the concept of combining computers and networks to monitor and control devices has been around for decades. By the late 1970 for example, systems for remotely monitoring meters on the electrical grid via telephone lines were already in commercial use. In the 1990 advances in wireless technology allowed (machine-to-machine) enterprise and industrial solutions for equipment monitoring and operation to become widespread[8].

Using internet protocol (IP) to connect devices other than computers to the Internet is not a new idea. The first Internet “device”—an IP-enabled toaster that could be turned on and off over the Internet—was featured at an Internet conference in 1990. Over the next several years, other “things” were IP-enabled, including a soda machine at Carnegie Mellon University in the US and a coffee pot in the Trojan Room at the University of Cambridge in England. From these whimsical beginnings, a robust field of research and development into “smart object networking” helped create the foundation for today’s Internet of Things[8].

The term (IOT) defines as: a global network infrastructure, linking physical and virtual objects through the exploitation of data capture and communication capabilities. This infrastructure includes existing and evolving Internet and network developments. It will offer specific object-identification, sensor and connection capability as the basis for the development of independent cooperative services and applications.[8]

### **3.2 IOT Features**

The most important features of (IOT) include artificial intelligence, connectivity, sensors, active engagement, and small device use. A brief review of these features is given below:

- Artificial intelligence: The (IOT) essentially makes virtually anything “smart”, meaning it enhances every aspect of life with the power of data collection, artificial intelligence algorithms, and networks[9].

- Connectivity: New enabling technologies for networking, and specifically IOT networking, mean networks are no longer exclusively tied to major providers. Networks can exist on a much smaller and cheaper scale while still

being practical. IOT creates these small networks between its system devices[9].

– Sensors: IOT lose its distinction without sensors. They act as defining instruments which transform IOT from a standard passive network of devices into an active system capable of real-world integration[9].

- Active Engagement: Much of today's interaction with connected technology happens through passive engagement. IOT introduces a new paradigm for active content, product, or service engagement[9].

- Small Devices: Devices as predicted have become smaller, cheaper, and more powerful over time. IOT exploits purpose-built small devices to deliver its precision, scalability, and versatility[9].

### **IOT Advantages**

The advantages of IOT span across every area of lifestyle and business. Here is a list of some of the advantages that IOT has to offer:

- Improved Customer Engagement: Current analytics suffer from blind-spots and significant flaws in accuracy; and as noted, engagement remains passive. IOT completely transforms this to achieve richer and more effective engagement with audiences[8].

- Technology Optimization: The same technologies and data which improve the customer experience also improve device use, and aid in more potent improvements to technology. IOT unlocks a world of critical functional and field data[8].

### **IOT Disadvantages:**

Though IOT delivers an impressive set of benefits, it also presents a significant set of challenges. Here is a list of some its major issues:

- Security: IOT creates an ecosystem of constantly connected devices communicating over networks. The system offers little control despite any security measures. This leaves users exposed to various kinds of attackers[8].
- Privacy: The sophistication of IOT provides substantial personal data in extreme detail without the user's active participation[8].
- Complexity: Some find IOT systems complicated in terms of design, deployment, and maintenance given their use of multiple technologies and a large set of new enabling technologies[8].
- Flexibility: Many are concerned about the flexibility of an IOT system to integrate easily with another. They worry about finding themselves with several conflicting or locked systems[8].
- Compliance IOT: like any other technology in the realm of business, must comply with regulations. Its complexity makes the issue of compliance seem incredibly challenging when many consider standard software compliance a battle[8].
- Reduced Waste: IOT makes areas of improvement clear. Current analytics give us superficial insight, but IOT provides real-world information leading to more effective management of resources[8].
- Enhanced Data Collection: Modern data collection suffers from its limitations and its design for passive use. IOT breaks it out of those spaces, and places it exactly where humans really want to go to analyze our world. It allows an accurate picture of everything[8].

### **3.3 IOT Hardware**

The hardware utilized in IOT systems includes devices for a remote dashboard, devices for control, servers, a routing or bridge device, and sensors. These devices manage key tasks and functions such as system

activation, action specifications, security, communication, and detection to support-specific goals and actions.

### **3.3.1 IOT – Sensors**

The most important hardware in IOT might be its sensors. These devices consist of energy modules, power management modules, RF\* modules, and sensing modules. RF modules manage communications through their signal processing, Wi-Fi, ZigBee, Bluetooth, radio transceiver and duplexer.

The sensing module manages sensing through assorted active and passive measurement devices[10].

### **3.3.2 Wearable Electronics**

Wearable electronic devices are small devices worn on the head, neck, arms, torso, and feet[10].

### **3.3.3 Standard Devices**

The desktop, tablet, and cell phone remain integral parts of IOT as the command center and remotes[10].

- The desktop provides the user with the highest level of control over the system and its settings[10].
- The tablet provides access to the key features of the system in a way resembling the desktop, and also acts as a remote[10].
- The cell phone allows some essential settings modification and also provides remote functionality[10].

Other key connected devices include standard network devices like routers and switches[10].

### **3.4 IOT Software**

IOT software addresses its key areas of networking and action through platforms, embedded systems, partner systems, and middleware. These individual and master applications are responsible for data collection, device integration, real-time analytics, and application and process extension within the IOT network.

It can be represented in detailed below:

#### **-Data Collection:**

This software manages sensing, measurements, light data filtering, light data security, and aggregation of data. It uses certain protocols to aid sensors in connecting with real-time, machine-to-machine networks. Then it collects data from multiple devices and distributes it in accordance with settings. It also works in reverse by distributing data over devices. The system eventually transmits all collected data to a central server[9].

#### **-Device Integration:**

Software supporting integration binds (dependent relationships) all system devices to create the body of the IOT system. It ensures the necessary cooperation and stable networking between devices. These applications are the defining software technology of the IOT network because without them, it is not an IOT system. They manage the various applications, protocols, and limitations of each device to allow communication[9].

#### **-Real-Time Analytics:**

These applications take data or input from various devices and convert it into viable actions or clear patterns for human analysis. They analyze information based on various settings and designs in order to perform automation-related tasks or provide the data required by industry[9].



-Application and Process Extension:

These applications extend the reach of existing systems and software to allow a wider, more effective system. They integrate predefined devices for specific purposes such as allowing certain mobile devices or engineering instruments access. It supports improved productivity and more accurate data collection [9].

### **3.5 IOT Technology and Protocol**

IOT primarily exploits standard protocols and networking technologies. However, the major enabling technologies and protocols of IOT are RFID (radio-frequency identification), NFC (near-field communication), low-energy Bluetooth, low-energy wireless, low-energy radio protocols, LTE-A, and Wi-Fi Direct. These technologies support the specific networking functionality needed in an IOT system in contrast to a standard uniform network of common systems[9].

-NFC and RFID:

RFID technology employs 2-way radio transmitter-receivers to identify and track tags associated with objects. NFC consists of communication protocols for electronic devices, typically a mobile device and a standard device [9].

-Low-Energy Bluetooth:

This technology supports the low-power, long-use need of IOT function while exploiting a standard technology with native support across systems[9].

-Low-Energy Wireless:

This technology replaces the most power hungry aspect of an IOT system. Though sensors and other elements can power down over long periods, communication links (i.e., wireless) must remain in listening mode. Low-

energy wireless not only reduces consumption, but also extends the life of the device through less use[9].

-Radio Protocols:

ZigBee, Z-Wave, and Thread are radio protocols for creating low-rate private area networks. These technologies are low-power, but offer high throughput unlike many similar options[9].

-Wi-FiDirect:

Wi-Fi Direct eliminates the need for an access point. It allows peer-to-peer connections with the speed of Wi-Fi, but with lower latency[9].

## **3.6 IOT Applications**

IOT has many applications across the real world:

-Smart cities.

-Energy Management.

-Manufacturing.

-Medical and healthcare systems.

-Building and home automation.

-Transportation

### **3.6.1 Smart Cities**

The IOT has the potential to transform entire cities by solving real problems citizens face each day. With the proper connections and data, the Internet of Things can solve traffic congestion issues and reduce noise, crime, and pollution[10].

### **3.6.2 Energy management**

Integration of sensing and actuation systems, connected to the Internet, is likely to optimize energy consumption as a whole. It is expected that IOT devices will be integrated into all forms of energy consuming devices (switches, power outlets, bulbs, televisions, etc.) and be able to communicate with the utility supply company in order to effectively balance power generation and energy usage[10].

### **3.6.3 Manufacturing**

Network control and management of manufacturing equipment, asset and situation management, or manufacturing process control bring the IOT within the realm on industrial applications and smart manufacturing as well[10].

### **3.6.4 Medical and healthcare systems**

IOT devices can be used to enable remote health monitoring and emergency notification systems. These health monitoring devices can range from blood pressure and heart rate monitors to advanced devices capable of monitoring specialized implants, such as pacemakers or advanced hearing aids[10].

### **3.6.5 Building and home automation**

IOT devices can be used to monitor and control the mechanical, electrical and electronic systems used in various types of buildings (e.g., public and private, industrial, institutions, or residential)in home automation and building automation systems[10].

### **3.6.6 Transportation**

The IOT can assist in integration of communications, control, and information processing across various transportation systems[10].

### **3.7 Challenges Face IOT**

There are many challenges which face IOT technology.

-Security:

As IOT becomes a key element of the future internet and critical national/international infrastructure, the need to provide adequate security for the IOT infrastructure becomes ever more important.

IOT applications use sensors and actuators embedded in the environment and they collect large volumes of data on room temperatures, humidity, and lighting to optimize energy consumption and avoid operational failures that have a real impact on the environment[10].

-Standards:

As much of the information in an IOT system may be personal data, there is a requirement to support anonymity and restrictive handling of personal information.

Lack of standards and documented best practices have a greater impact than just limiting the potential of IOT devices. As APNIC's Geoff Huston has pointed out previously, absence of standards can enable stupid behavior by IOT devices[10].

-Regulation:

Like privacy, there are a wide range of regulatory and legal questions surrounding the IOT, which need thoughtful consideration[10].

-Development:

The broad scope of IOT challenges will not be unique to industrialized countries. In fact, the IOT holds significant promise for delivering social and economic benefits to emerging and developing economies[10].

# **CHAPTER FOUR**

## **BUILDING MANAGEMENT SYSTEM**

### **CONTROL**

#### **4.1 Introduction**

A building management system can link multiple control systems and facilitate the control of any building service through a communication

Network connected to software

Through the software, real time performance can be observed and settings can be adjusted. Often, the system is translated to web-based software making the system intuitive to a broad range of users and sometimes allows the system to be monitored and adjusted from remote locations.

#### **4.2 System Components**

The main concept of the block diagram is shown in Figure 4.1 that describes the inputs and outputs components .The input signals received from sensors and switches in order to activate the outputs actuators.

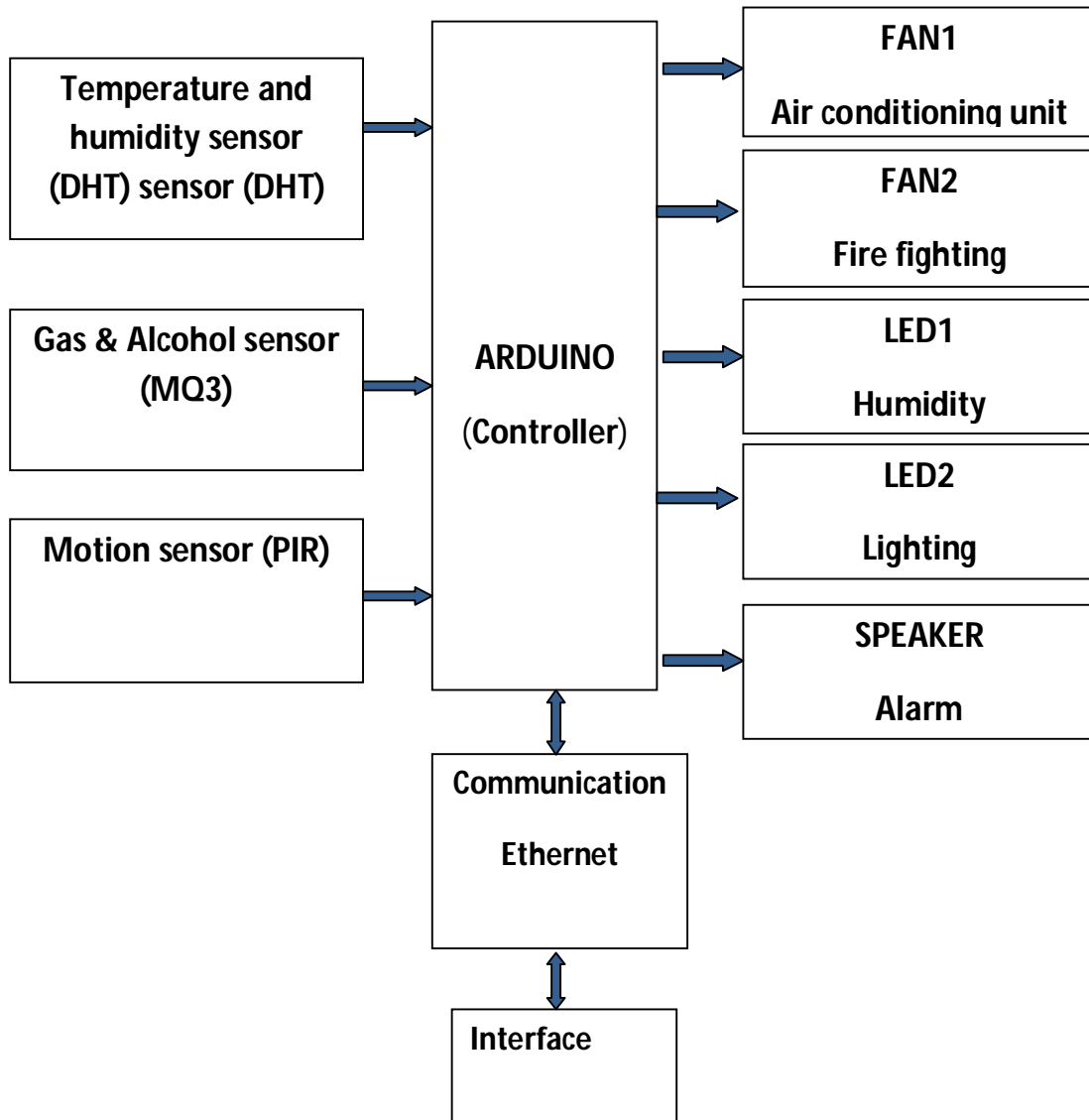

Figure 4.1: block diagram of building management system

The system components selected according to the functionality of building management system and the components are:

-Arduino Uno ,Humidity and temperature sensor (DHT),Ethernet,Gas and alcohol sensor (MQ3),motion sensor (PIR),Relay,Fan,light emitting diode

### **4.2.1 Arduino Uno**

An Arduino is a single-board microcontroller and a software suite for programming it. The hardware consists of a simple open hardware design for the controller with an ATmel328 processor and on-board I/O support. The software consists of a standard programming language and the boot loader that runs on the board. The Arduino Uno is a microcontroller board based on the ATmega328. It has 14 digital input/output pins (of which 6 can be used as Pulse Width Modulation (PWM) outputs), 6 analog inputs, a 16 MHz ceramic resonator, a Universal Serial Bus (USB) connection, a power jack, an In-Circuit Serial Programming (ICSP) header, and a reset button. It contains everything needed to support the microcontroller; simply connect it to a computer with a USB cable or power it with an AC-to-DC adapter or battery to get started. The Arduino board is made up of an Atmel328 Microprocessor, a crystal or oscillator (a crude clock that sends time pulses at a specified frequency to enable it to operate at the correct speed), and a 5-volt linear regulator. Depending on what type of Arduino you have, it may also have a USB socket to connect to a PC or Mac for uploading or retrieving data. The board exposes the microcontroller's I/O (input/output) pins so that you can connect those pins to other circuits or to the sensors.

To program the Arduino use (Integrated Development Environment) IDE, which is a piece of free software in which the code is written in the language that the Arduino understands (a language called C). The IDE lets a computer program be written, which is a set of step-by-step instructions that

is uploaded to the Arduino. The Arduino will then carry out these instructions and interact with whatever has been connected to the Arduino world. Programs are known as sketches. Figure 4.2: the Arduino controller

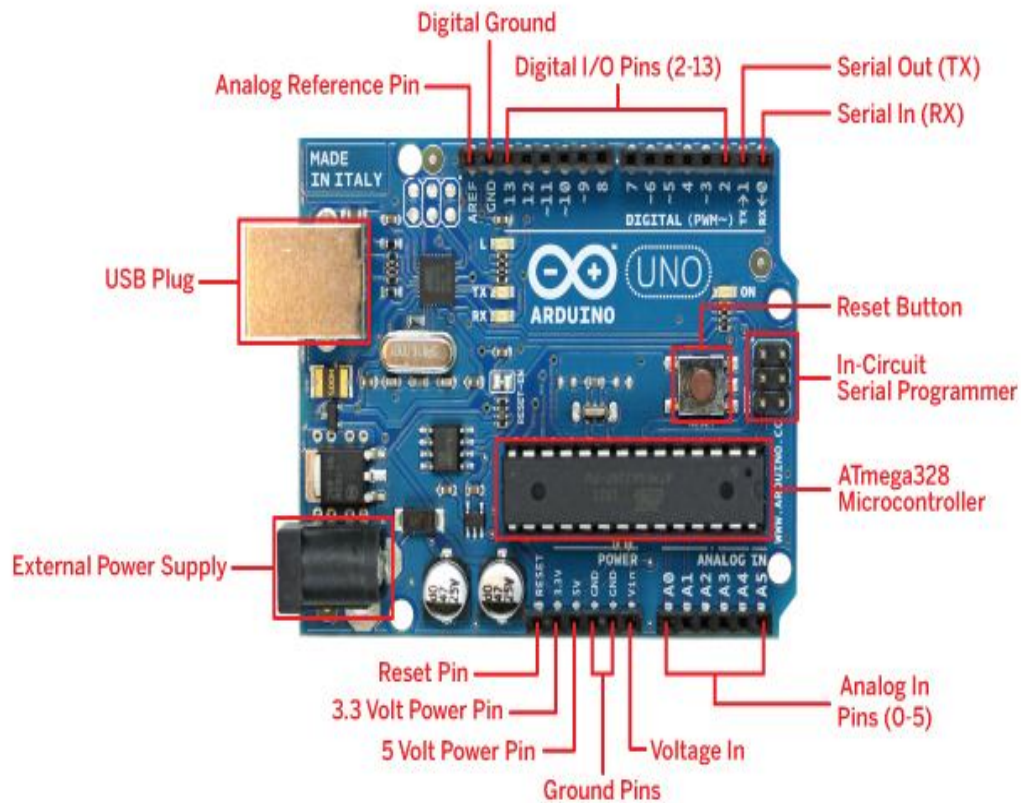

Figure 4.2: Arduino controller

### 4.2.2 DHT sensor

DHT11 Temperature & Humidity Sensor features a temperature and humidity sensor complex with a calibrated digital signal output. By using the exclusive digital-signal-acquisition technique and temperature and humidity sensing technology, it ensures high reliability and excellent long-term stability. This sensor includes a resistive-type humidity measurement component and an NTC temperature measurement component, and connects to a high-performance 8-bit microcontroller, offering excellent quality, fast response,

Anti-interference ability and cost-effectiveness.





Figure 4.3: DHT Sensor

Each DHT11 element is strictly calibrated in the laboratory that is extremely accurate on humidity calibration. The calibration coefficients are stored as programmers in the OTP memory, which are used by the sensor's internal signal detecting process. The single-wire serial interface makes system integration quick and easy. Its small size, low power consumption and up-to-20 meter signal transmission making it the best choice for various applications, including those most demanding ones. The component is 4-pin single row pin package. It is convenient to connect and special packages can be provided according to users' request. The figure (4.4) show the DHT element

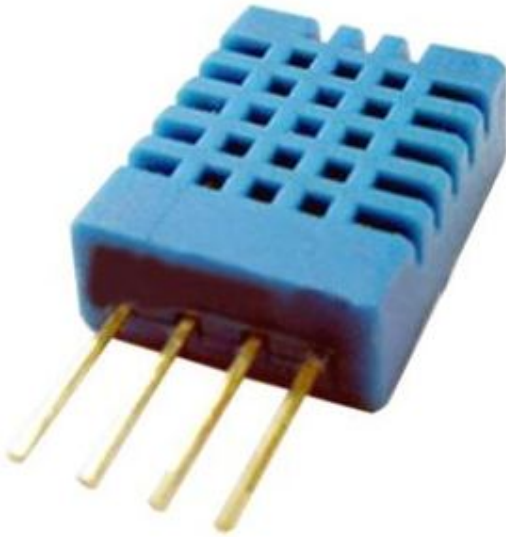

Figure 4.4: the DHT element

### **4.2.3 Ethernet**

The Arduino Ethernet Shield allows an Arduino board to connect to the internet. It is based on the Wiznet W5100 Ethernet chip. The Wiznet W5100 provides a network (IP) stack capable of both TCP and UDP. It supports up to four simultaneous socket connections. Use the Ethernet library to write sketches which connect to the internet using the shield. The Ethernet shield connects to an Arduino board using long wire-wrap headers which extend through the shield. This keeps the pin layout intact and allows another shield to be stacked on top. The latest revision of the shield adds a micro-SD card slot, which can be used to store files for serving over the network. Figure 4.5 the Ethernet Shield

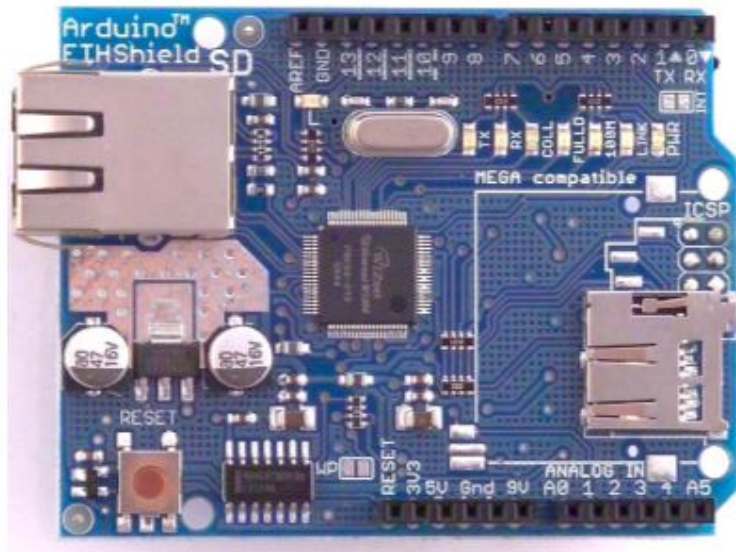

Figure 4.5: Ethernet shield

#### 4.2.4 Gas and alcohol sensor (MQ3)

When the target alcohol gas exist, the sensors conductivity is higher along with the gas concentration rising.

MQ3 gas sensor has high sensitivity to alcohol, and has good resistance to disturb of gasoline, smoke and vapor; the sensor could to detect alcohol with different application character configuration.

High sensitivity to alcohol gas

Long life and low cost

Simple drive circuit

Fast response and high sensitivity Application

Vehicle alcohol detector

They are suitable for alcohol check

The Figure 4.6: the MQ3 sensor



Figure 4.6: the MQ3 sensor

#### 4.2.5 PIR sensor

PIR sensors allow you to sense motion, almost always used to detect whether a human has moved in or out of the sensors range. They are small, inexpensive, low-power, easy to use and don't wear out. For that reason they are commonly found in appliances and gadgets used in homes or businesses. They are often referred to as PIR, "Passive Infrared", "Pyroelectric", or "IR motion" sensors.

PIR sensors are more complicated than many of the other sensors explained in these tutorials (like photocells, FSRs and tilt switches) because there are multiple variables that affect the sensors input and output. To begin explaining how a basic sensor works, we'll use this rather nice diagram

The PIR sensor itself has two slots in it, each slot is made of a special material that is sensitive to IR. The lens used here is not really doing much and so we

see that the two slots can 'see' out past some distance (basically the sensitivity of the sensor). When the sensor is idle, both slots detect the same amount of IR, the ambient amount radiated from the room or walls or outdoors. When a warm body like a human or animal passes by, it first intercepts one half of the PIR sensor, which causes a positive differential change between the two halves. When the warm body leaves the sensing area, the reverse happens, whereby the sensor generates a negative differential change. These change pulses are what is detected.

The Figure 4.7: the PIR sensor



Figure 4.7: PIR sensor

#### **4.2.6 Relay**

The Relay module is an electrically operated switch that allows you to turn on or off a circuit using voltage and/or current much higher than a microcontroller could handle. There is no connection between the low voltage

circuit operated by the microcontroller and the high power circuit. The relay protects each circuit from each other.

The each channel in the module has three connections named NC, COM, and NO. Depending on the input signal trigger mode, the jumper cap can be placed at high level effective mode which 'closes' the normally open (NO) switch at high level input and at

Low level effective mode which operates the same but at low level input.

### Specifications

On-board EL817 photoelectric coupler with photoelectric isolating anti-interference ability strong On-board 5V, 10A / 250VAC, 10A / 30VDC relays Relay long life can absorb 100000 times in a row Module can be directly and MCU I/O link, with the output signal indicator Module with diode current protection, short response time PCB Size: 45.8mm x 32.4mm

### Pin Configuration

The Figure 4.8: the Relay diagrams



Figure 4.8: Relay diagram

Relay contain five pin there are:

- VCC: 5V DC (No.1)
- COM: 5V DC (No.2)
- IN1: high/low output (No.3)
- IN2: high/low output (No.4)
- GND: ground (No.5)

Figure 4.9: the Relay pin



Figure 4.9: Relay pin

Wiring Diagram

Figure 4.10: Relay wiring diagram

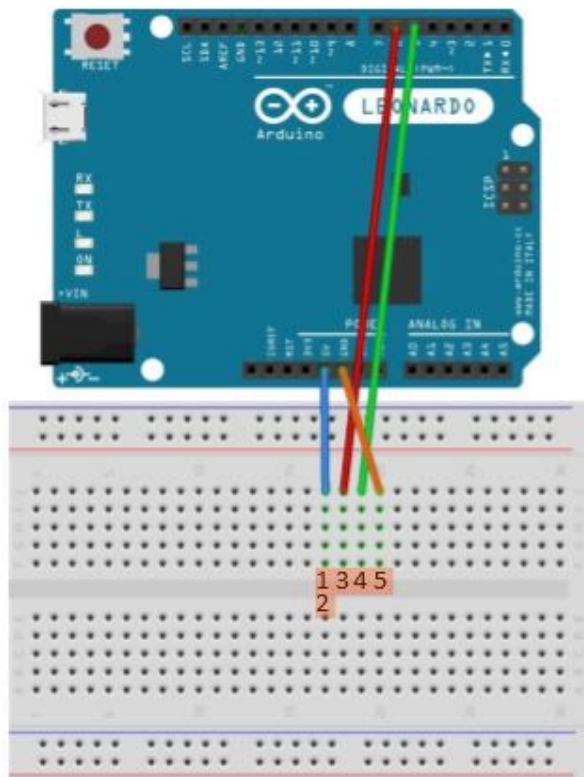

Figure 4.10: Relay wiring diagram

### Schematic Diagram

Figure 4.11: Relay schematic diagram

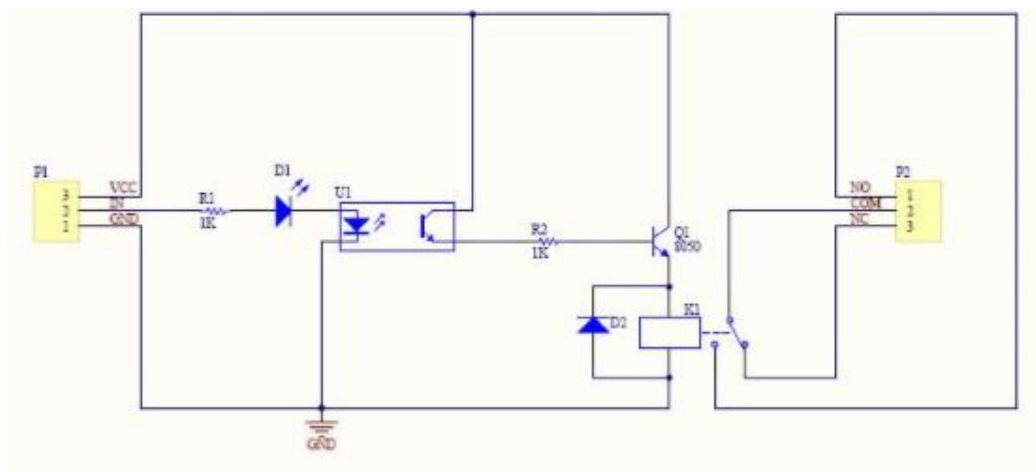

Figure 4.11: Relay schematic diagram



## **Relay Testing**

The components to be used are:

- Microcontroller (any compatible Arduino)
- channel 5V 10A relay module
- Pin connectors
- Breadboard
- USB cable
- Connect the components based on the figure shown in the wiring diagram using pin connectors. VCC and COM pin is connected to the 5V power supply, GND pin is connected to the GND, IN1 and IN2 pins are connected to the digital I/O pin. Pin number will be based on the actual program code.
- After hardware connection, insert the sample sketch into the Arduino IDE.
- Using a USB cable, connect the ports from the microcontroller to the computer.
- Upload the program.

### **4.2.7 Fan:**

DC brushless fan that use power 5-volt to indicate, this fan use to specific application exactly in small experience.



Figure 4.12: fan

#### **4.2.8 light-emitting diode (LED)**

A light-emitting diode (LED) is a special kind of diode that glows when electricity passes through it. Most LEDs are made from a semi-conducting material called gallium arsenide phosphide. LEDs can be bought in a range of colours. They can also be bought in forms that will switch between two colors (bi-color), three colors (tri-color) or emit infra-red light. In common with all diodes, the LED will only allow current to pass in one direction. The cathode is normally indicated by a flat side on the casing and the anode is normally indicated by a slightly longer leg. The current required to power an LED is usually around 20 mA. Figure (4.13) show LED

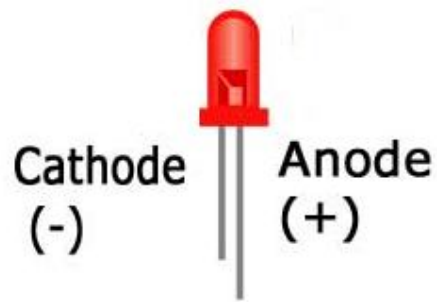

Figure (4.13): LED

### **4.3 System Simulation**

The Proteus schematic capture module lies at the heart of the system. It combines the design environment with the ability to define most aspects of the drawing appearance. Proteus provides a full real life simulation.

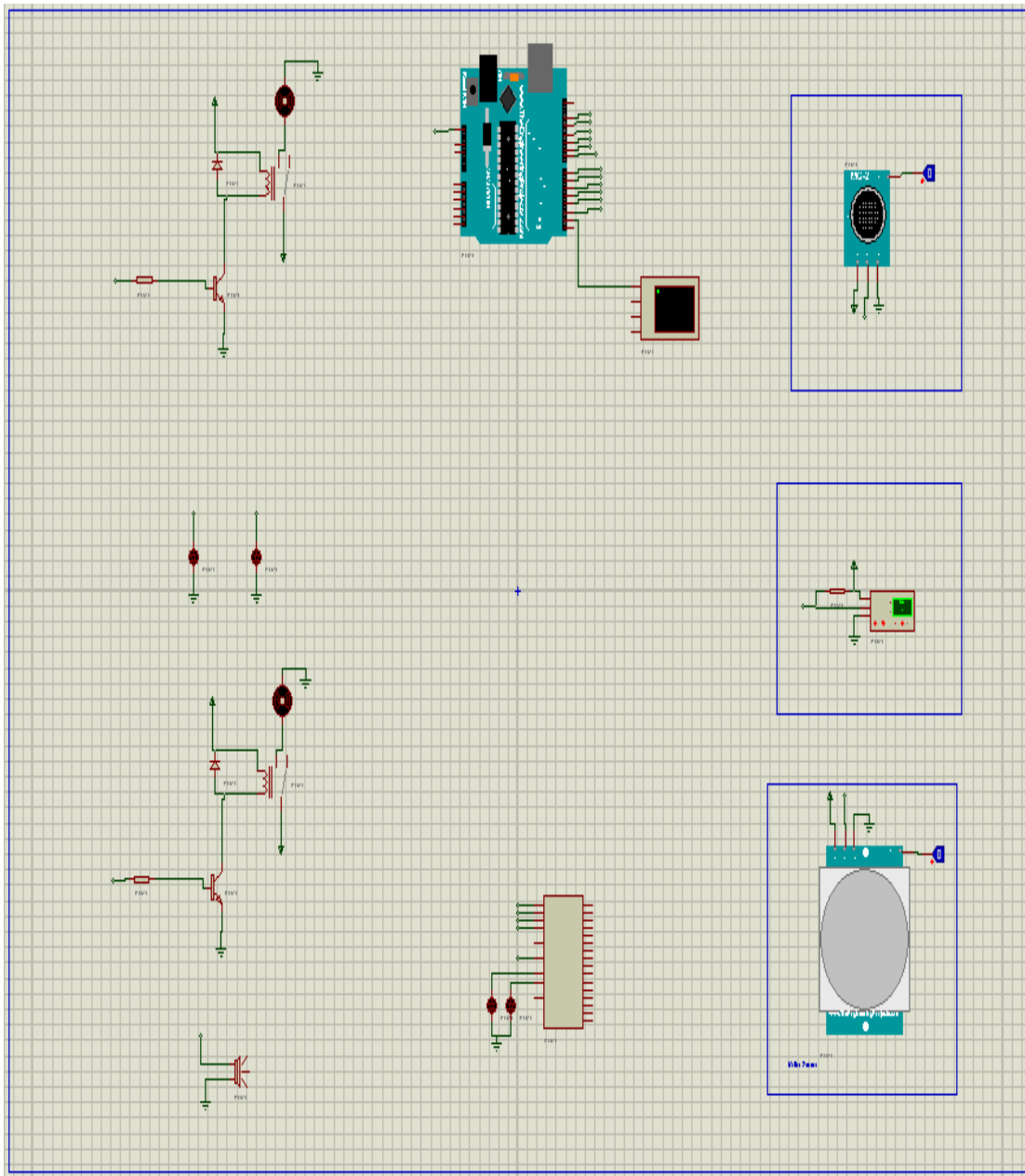

Figure 4.14: Schematic capture of the system

If the Humidity of room increased more than 75 and the temperature of room becomes high more than 31 the DHT sensor send signal to Arduino in order to turn on the fun1 to degrees the temperature of room, and turn on the led actuator And the Arduino send data to web site by Ethernet throw frame and

the wife side includes manual and manually control operation figure4.15: the DHT sensor operation

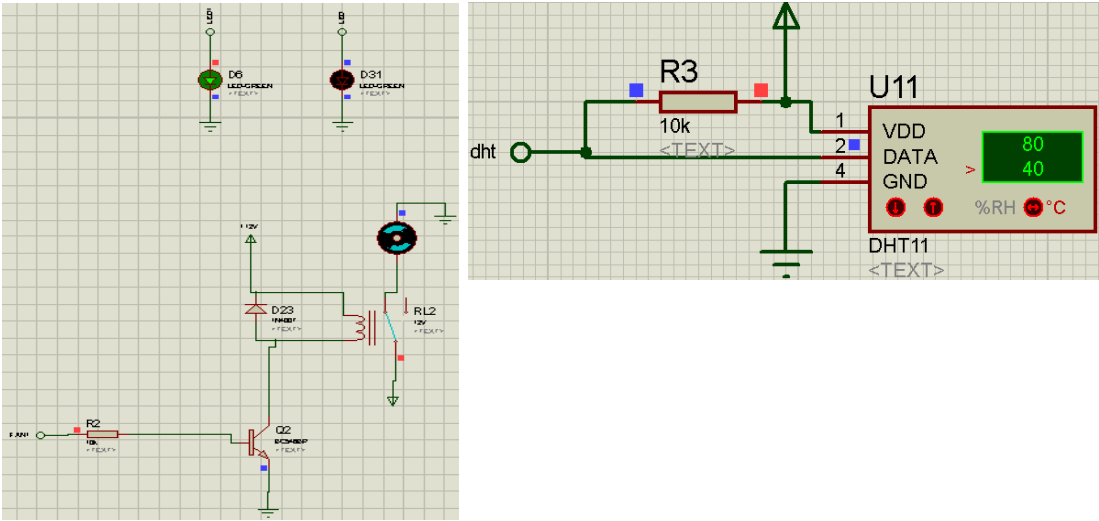

Figure 4.15: DHT sensor operation

When sensitive any motion, it send signal to Arduino ,Arduino open the led in room, and send the condition about the sensor to and led to website throw frame figure 4.16: PIR operation PIR sensor

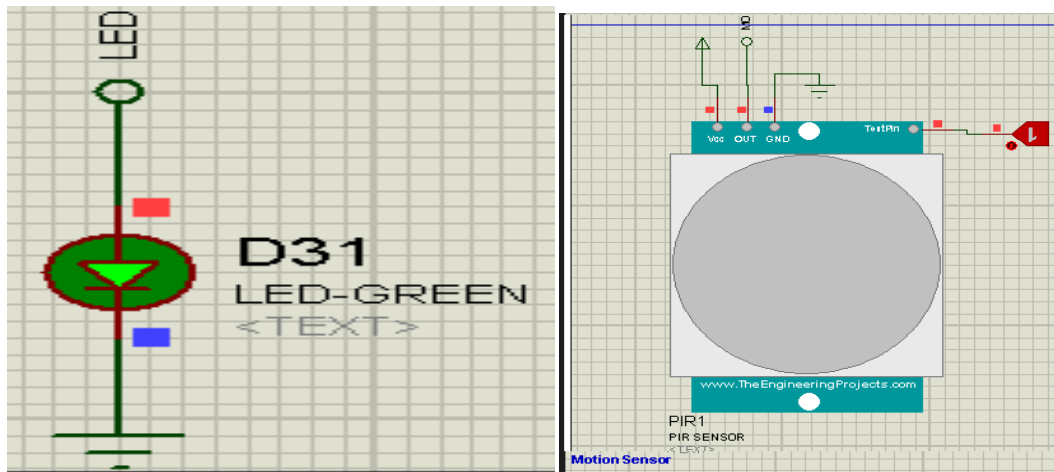

Figure 4.16: PIR sensor operation

When the gas of the room increases from normally range the MQ3 sensor sensitive the gas and send signal to the Arduino to turn on the fun2 to digrees the room gas and the Arduino send the condition of MQ3 sensor and fun2 to the website throw the frame figure 4.17: MQ3 operation

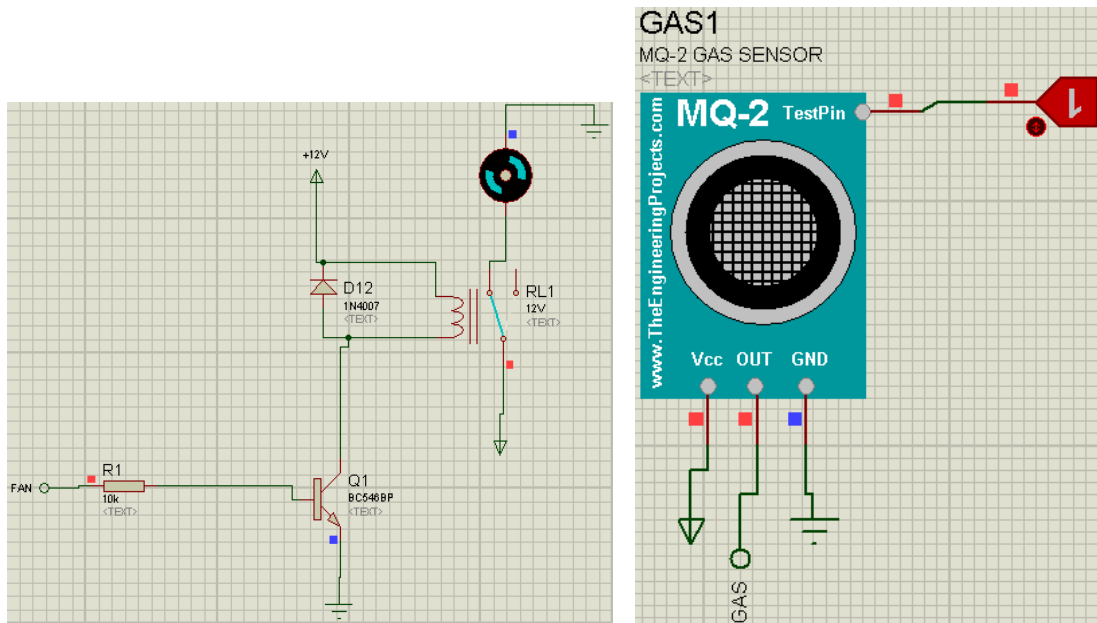

Figure 4.17:MQ3 sensor operation

## 4.4 System Model

Figure 4.18 and 4.19 show the system model



Figure 4.18 System model



Figure 4.19: System model



# CHAPTER FIVE

## CONCLUSION AND RECOMMENDATIONS

### 5.1 Conclusion

-The BMS has faster and better responsiveness to occupant needs and trouble conditions; the cost of energy was reduced through centralized management of control and energy management programs.

The Arduino Uno controller provides:

- Good control of internal comfort conditions.
- Possibility of individual room control.
- Effective monitoring and targeting of energy consumption.
- Effective response to HVAC-related complaint.
- Save time and money during the maintenance.
- Flexibility on change of building use.

IOT technology monitoring the system condition and give smart control to the system by using web site

The system can be monitored and controlled from anywhere by using IOT

### 5.2 Recommendation

- Apply other types of controllers to control the main components of the BMS.
- Apply a BMS in other areas of applications such as communication towers.
- can use wireless sensor network to the IOT system.
- Can use android application to monitor and control the system.

## REFERNCE

- [1] Honeywell “Engineering manual of automatic control for commercial buildings” 1997
- [2] Brambley” Advanced Sensors and Controls for Building Applications” Market Assessment and Potential R&D Pathways .2005
- [3] Roth”Energy Consumption Characteristics of Commercial Building HVAC Systems Volume III” Energy Savings Potential. 2002
- [4] Walter T. Grondzik, Alison G. Kwok, John s. Reynolds , “ Mechanical and Electrical Equipment for Buildings” ,John Wiley & sons, Inc, 2010.
- [5] Robert McDowall” Fundamentals of HVAC systems”. 2006.
- [6] Frank Strobl, Alexander Wisspeintner , “ Specification of and Elevator Control System”, SFB 342 , 1999
- [7] Terry Kennedy john E.traister“ Low voltage wiring security/fire alarm system “third edition.
- [8] Adrian McEwen And Hakim Cassimaly “Design The Internet of things”,john Wiley and sons,2014.
- [9]OvidiuVermesan and peter friess Internet Of Things From Research And Innovation To Market Deployment.
- [10]CunoPFister”Getting Start with Internet Of Things”,Cambridge,may 2011.

## Appendix

```
#include <SPI.h>
```

```
#include <EtherCard.h>
```

```
#include <IPAddress.h>
```

```
#include <net.h>
```

```
#include <EthernetUdp.h>
```

```
#include <dht.h>
```

```
#include <EEPROM.h>
```

```
//////////////////////////////////pin config//////////////////////////////////
```

```
constintmo=6;
```

```
intmo_val;
```

```
constint gas=5;
```

```
intgas_val;
```

```
constint fan1=4;
```

```
constint fan2=8;
```

```
constint led1=3;
```

```
constint led2=9;
```

```
constintsou=2;
```

```
int fan1_st,fan2_st,led1_st,led2_st;
```

```
#define DHT11_PIN 7
```

```
dht DHT;

////////////////////////////////////

int i;

char form2[50];

char buffer[500];

char numbers[22];

charForm_res[5];

intaa;

inttt;

////////////////////////////////////

voidmotion_read(){

mo_val= digitalRead(mo);

}

////////////////////////////////////gas////////////////////////////////////

voidgas_read(){

gas_val=digitalRead(gas);

}
```

```

////////////////////////////////////

void dht_read(){

int chk = DHT.read11(DHT11_PIN);

}

////////////////////////////////////AUTO////////////////////////////////////

void Auto(){

if(DHT.temperature>=31){digitalWrite(fan2,HIGH);fan2_st=1;}

if(DHT.temperature<=30){digitalWrite(fan2,LOW);fan2_st=0;}

if(DHT.humidity>=75){digitalWrite(led2,HIGH);led2_st=1;}

if(DHT.humidity<=74){digitalWrite(led2,LOW);led2_st=0;}

if(mo_val==HIGH){

digitalWrite(led1,HIGH);led1_st=1;}

if(mo_val==LOW){

digitalWrite(led1,LOW);led1_st=0;

}

if(gas_val==HIGH){

digitalWrite(fan1,HIGH);fan1_st=1;

digitalWrite(sou,HIGH);}

if(gas_val==LOW){

digitalWrite(fan1,LOW);fan1_st=0;

```

```
digitalWrite(sou,LOW);}

}
```

```
//////////Manoul//////////
```

```
voidManoul(){
```

```
if(Form_res[2]==0x31){ digitalWrite (fan1,HIGH);fan1_st=1;}
```

```
if(Form_res[2]==0x30){ digitalWrite (fan1,LOW);fan1_st=0;}
```

```
if(Form_res[3]==0x31 ){ digitalWrite (fan2,HIGH);fan2_st=1;}
```

```
if(Form_res[3]==0x30){ digitalWrite (fan2,LOW);fan2_st=0;}
```

```
if(Form_res[4]==0x31){ digitalWrite (led1,HIGH);led1_st=1;}
```

```
if(Form_res[4]==0x30){ digitalWrite (led1,LOW);led1_st=0;}
```

```
if(Form_res[5]==0x31){ digitalWrite (led2,HIGH);led2_st=1;}
```

```
if(Form_res[5]==0x30){ digitalWrite (led2,LOW);led2_st=0;}
```

```
}
```

```
//////////
```

```
//////////Ethernet//////////
```

```
#define STATIC 1 // set to 1 to disable DHCP (adjust myip/gwip values  
below)
```



```
IPAddresssrc(src_ip[0],src_ip[1],src_ip[2],src_ip[3]);

Serial.print("dest_port: ");

Serial.println(dest_port);

Serial.print("src_port: ");

Serial.println(src_port);

Serial.print("src_port: ");

ether.printIp(src_ip);

Serial.println();

Serial.println("data: ");

Serial.println(data);

Form_res[1]=char(data[1]);

Form_res[2]=char(data[2]);

Form_res[3]=char(data[3]);

Form_res[4]=char(data[4]);

Form_res[5]=char(data[5]);

if(data[0]==0x31){

numbers[1]=';';
```



```
numbers[2]=((aa)/10)%10+48;

numbers[3]=(aa)%10+48;

numbers[4]=';';

numbers[5]=((tt)/10)%10+48;

numbers[6]=(tt)%10+48;

numbers[7]=';';

numbers[8]=(gas_val+48);

numbers[9]=';';

numbers[10]=(mo_val+48);

numbers[11]=';';

numbers[12]=(led1_st+48);

numbers[13]=';';

numbers[14]=(led2_st+48);

numbers[15]=';';

numbers[16]=(fan1_st+48);

numbers[17]=';';

numbers[18]=(fan2_st+48);

numbers[19]=';';

numbers[20]='*';

form2[0]='#';
```

```

for (int n=1; n<=21; n++){

form2[n]=numbers[n];

delay(2);

}

ether.sendUdp(form2 ,sizeof(form2), 1337, src_ip, src_port ); }

}

void setup() {

// put your setup code here, to run once:

Serial.begin(9600);

pinMode(fan1,OUTPUT);

pinMode(fan2,OUTPUT);

pinMode(led1,OUTPUT);

pinMode(led2,OUTPUT);

pinMode(sou,OUTPUT);

Serial.println("\nHI ");

if (ether.begin(sizeof Ethernet::buffer, mymac) == 0){

Serial.println( "Failed to access Ethernet controller");}

Serial.println( "step1");

```

```
#if STATIC

Serial.println( "step1");

ether.staticSetup(myip, gwip);

#else

if (!ether.dhcpSetup())

Serial.println("DHCP failed");

#endif

ether.printIp("IP: ", ether.myip);

ether.printIp("GW: ", ether.gwip);

ether.udpServerListenOnPort(&udpSerialPrint, 1337);

}

void loop() {

    // put your main code here, to run repeatedly:

ether.packetLoop(ether.packetReceive());

aa=DHT.humidity;

tt=DHT.temperature;

motion_read();
```

```
gas_read();  
  
dht_read();  
  
if(Form_res[1]==0x31){  
  
Manoul();  
  
}  
  
if(Form_res[1]==0x30){  
  
Auto();  
  
}  
  
}
```