

بسم الله الرحمن الرحيم

Sudan University of Science and Technology

College of Engineering

School of Electrical and Nuclear

**PASSWORD BASED CIRCUIT
BREAKER**

قاطع كهربائي مزود بكلمة مرور

A Project Submitted In Partial Fulfillment for the
Requirements of the Degree of B.Sc. (honor) In Electrical
Engineering

Prepared By:

1. Abubakr Khalid Omer Abbas
2. Alfyad Alfatih Yousif Mohammed
3. Ghaith Alfatih Mohammed Shreef

Supervised By:

Ust. Maha Osman Mohammed

October 2017

الآية

قال تعالى :

بسم الله الرحمن الرحيم

" اللَّهُ لَا إِلَهَ إِلَّا هُوَ الْحَيُّ الْقَيُّومُ لَا تَأْخُذُهُ سِنَّةٌ وَلَا نَوْمٌ لَهُ مَا فِي السَّمَاوَاتِ وَمَا فِي الْأَرْضِ مَنْ ذَا الَّذِي يَشْفَعُ عِنْدَهُ إِلَّا بِإِذْنِهِ يَعْلَمُ مَا بَيْنَ أَيْدِيهِمْ وَمَا خَلْفَهُمْ وَلَا يُحِيطُونَ بِشَيْءٍ مِّنْ عِلْمِهِ إِلَّا بِمَا شَاءَ وَسِعَ كُرْسِيُّهُ السَّمَاوَاتِ وَالْأَرْضَ وَلَا يَئُودُهُ حِفْظُهُمَا وَهُوَ الْعَلِيُّ الْعَظِيمُ "

صدق الله العظيم

"سورة البقرة 255"

DEDICATION

We dedicated this project to our parents who help us to succeed in anything in our life and encourage them to us, in addition to our families and friends, we dedicated to all those who helped us and all who wished us well.

ACKNOWLEDGEMENT

All praise and thanks are due to the almighty allah for guides us to the right path and helped us to complete this project successfully. We would like to thank our supervisor for her support and encouragement during this project, it would never have been possible for us to take this project to completion without their support and encouragement.

Abstract

This project focuses on the safety of the lineman while working, so they do not feel the sudden electric shocks. As the lineman has to deal with live wires very often, the probability of critical accidents are already very high.

Therefore it was necessary to provide a safely system of protection to avoid the accidents that may occurs in case of miss coordination between the lineman and station or control staff.

This project designed to give a high security system and that in switching off the meanly line with entering a password with a help of keypad. And here we have a safety system to work on it.

When the lineman staff get finished what they work on, they can activate the line by either of two ways, entering the same password that added before using keypad on station, or by sending SMS message including the password that selected before, and here we have a very important feature that is gain time.

مستخلص

هذا المشروع يهتم بتوفير الامان لرجل الصيانة اثناء قيامه بعمله حتى لا يخالهم الشعور بحدوث الصدمات المفاجئة التي تنتج من ارجاع الخط اثناء عملهم. إن احتمالية حدوث الإصابات في هذا العمل (النطاق) كبيرة جدا في حالة عدم التنسيق بين رجل الصيانة و قسم التحكم المتواجد في المحطة.

لذلك كان لابد من توفير نظام حماية بدقة عالية حتى نتجنب تلك الحوادث التي يمكن ان تنتج من سوء التنسيق بين رجل الصيانة وقسم التحكم.

تم تصميم هذا المشروع لتوفير نظام حماية آمن وذلك بتأمين الخط المعني عن طريق فصله بعد إدخال كلمة سر بواسطة لوحة مفاتيح وبذلك يمكن التعامل مع الخط بطريقة آمنة, بعد الإنتهاء من الصيانة يتم إرجاع الخط إما عن طريق لوحة المفاتيح المتواجدة في المحطة, أو عن طريق إرسال رسالة نصية محتوية على كلمة السر المختارة مسبقا مما يعطي ميزة مهمة جدا متمثلة في كسب الوقت.

TABLE OF CONTENTS

	Page No.
الاية	i
DEDICATION	ii
ACKNOWLEDGMENT	iii
ABSTRACT	iv
مستخلص	v
TABLE OF CONTENTS	vi
LIST OF FIGURES	viii
LIST OF ABBREVIATIONS	ix
CHAPTER ONE	
INTRODUCTION	
1.1 General Concepts	1
1.2 Problem Statement	1
1.3 Objectives	2
1.4 Methodology	2
1.5 Project Layout	2
CHAPTER TWO	
LITREATURE REVIEW	
2.1 Control System	3
2.2 Global System for Mobile Communications (GSM)	5
2.3 Circuit Breaker	6
2.4 Microcontroller	20
2.5 Relays	23

**CHAPTER THREE
SYSTEM HAEDWARE AND SOFTWARE
CONSIDERATION**

3.1 Using transistors as a switch	25
3.2 Arduino	25
3.3 Relay interfacing with arduino	26
3.4 Setting up the LCD	27
3.5 Interface the keypad to Arduino	29
3.6 Gsm module interfacing with arduino	30
3.7 block diagram	31
3.8 Wire diagram	32

**CHAPTER FOUR
SYSTEM IMPLEMENTATION AND TESTING**

4.1 System Implementation	33
4.2 The practical circuit	36

**CHAPTER FIVE
CONCLUSION AND RECOMMENDATIONS**

5.1 Conclusion	38
5.2 Recommendations	39
REFERENCES	40
APPENDIX	41

LIST OF FAGURES

Figure No.	Title	Page No.
2.1	Uplink and downlink	6
2.2	Oil circuit breaker	9
2.3	Plain break oil circuit breakers	11
2.4	Low oil circuit breaker	12
2.5	Axial blast air circuit breaker	15
2.6	Cross blast air circuit breaker	15
2.7	Radial blast air circuit breaker	16
2.8	Sulphur Hexafluoride (SF ₆) Circuit Breaker	17
2.9	Vacuum circuit breaker	19
2.10	The relay	24
3.1	Arduino board	26
3.2	Relay point	26
3.3	with headers soldered on	27
3.4	3×4 Hex keypad	29
3.5	Internal structure and pin notation	29
3.6	SIM900A GSM module	30
3.7	Block diagram	31
3.8	Wire diagram	32
4.1	Burn the code	33
4.2	DC and AC supplies	34
4.3	Entering the password	34
4.4	Appearance of password in LCD	34
4.5	Accept the correct password	35
4.6	Change of password	35
4.7	GSM mode	35
4.8	The practical circuit in normal condition	36
4.9	The practical circuit after detach condition	37

LIST OF ABBREVIATIONS

LCD	Liquid Crystal Displays
GSM	Global system for mobile
SISO	Single-input and single-output
PID	Proportional Integral-Derivative controllers
MIMO	multiple-input and multiple-output
SMS	Short Message Service
FDMA	Frequency Division Multiple Access
TDMA	Time Division Multiple Access
DC	Direct Current
AC	Alternating Current
SF6	Sulphur Hexafluoride
CPU	Central Processing Unit
RAM	Random Access Memory
ROM	Read Only Memory
NC	Normally Close
NO	Normally Open

CHAPTER ONE

INTRODUCTION

1.1 General Concepts

In previous years, the problem of lack coordination between the electric power station and the maintenance team that in switch off the circuit breakers during the line men on their work or has not finished yet removing or clearing faults, causing a high damages including injury the team of maintenance with an electric shocks may lead to death or combustion at least, also include damages to the equipments that use.

So there must be a way to secure and gives a protection to the line man or the maintenance team by not returning the circuit breaker while the maintenance team on a work and that by the line man himself and this insurance is in the form of a password entered by a keypad located in the station, or by a sending a message to the controller include the password.

1.2 Problem Statement

To give an environment to the line man about no one can return the line unless he get finished his work we made a circuit breaker based with password to achieve a safely system to the team that work on maintenance whatever it is.

A circuit breaker is an automatically operated electrical switch designed to protect an electrical circuit from damage caused by overload or short circuit. Its basic function is to detect a fault condition and interrupt current flow. Unlike a fuse, which operates once and then must be reset (either manually or automatically) to resume normal operation. When operate manually we see fatal electrical accidents to the line man are increasing during the electric line repair due to the lack of communication and coordination between the maintenance staff and the electric substation staff.

1.3 Objectives

The main objectives of this study are to:

- Design of Password Based Circuit Breaker circuit.
- Implementation of Password Based Circuit Breaker circuit.
- Simulate of controlling Password Based Circuit Breaker circuit.

1.4 Methodology

- Study all of previous studies.
- Research about circuit breaker types.
- Research about keypad, LCD and GSM module.
- Drawing the block and wire diagram.
- Starting with the programming logic.
- Design of Password Based Circuit Breaker.

1.5 Project Layout

This project consists of five chapters: Chapter One gives an introduction about the principles of the project, in addition its reasons, motivation and objectives. Chapter Two discusses the theoretical background of Control Systems, global system for mobile (GSM) System, Microcontroller System, circuit breaker Operated. Chapter Three describe the mechanical part of relay, The electrical part, Software and Hardware. Chapter Four shows the System Implementation and the experimental results. Finally, Chapter five provides the conclusion and recommendations.

CHAPTER TWO

LITREATURE REVIEW

2.1 Control System

There are two major divisions in control theory, namely, classical and modern, which have direct implications over the control engineering applications. The scope of classical control theory is limited to single-input and single-output (SISO) system design, except when analysing for disturbance rejection using a second input. The system analysis is carried out in the time domain using differential equations, in the complex- s domain with the Laplace transform, or in the frequency domain by transforming from the complex- s domain. Many systems may be assumed to have a second order and single variable system response in the time domain. A controller designed using classical theory often requires on-site tuning due to incorrect design approximations. Yet, due to the easier physical implementation of classical controller designs as compared to systems designed using modern control theory, these controllers are preferred in most industrial applications. The most common controllers designed using classical control theory is Proportional Integral-Derivative controllers (PID). A less common implementation may include either or both a Lead and Lag filter. The ultimate end goal is to meet requirements set typically provided in the time-domain called the Step response, or at times in the frequency domain called the Open-Loop response. The Step response characteristics applied in a specification are typically percent overshoot, settling time, etc. The Open-Loop response characteristics applied in a specification are typically Gain and Phase margin and bandwidth. These characteristics may be evaluated through simulation including a dynamic model of the system under control coupled with the compensation model. In contrast, modern control theory is carried out in the state space, and can deal with multiple-input and multiple-output (MIMO) systems. This overcomes the limitations of classical control theory in more sophisticated design problems, such as fighter aircraft control, with the limitation that no frequency domain analysis is possible. In modern design, a system is represented to the greatest advantage as a set of

decoupled first order differential equations defined using state variables. Nonlinear, multivariable, adaptive and robust control theories come under this division. Matrix methods are significantly limited for MIMO systems where linear independence cannot be assured in the relationship between inputs and outputs.

A control system is a device, or set of devices, that manages, commands, directs or regulates the behaviour of other devices or systems.

Industrial control systems are used in industrial production for controlling equipment or machines.

There are two common classes of control systems, open loop control systems and closed loop control systems. In open loop control systems output is generated based on inputs. In closed loop control systems current output is taken into consideration and corrections are made based on feedback. A closed loop system is also called a feedback control system.

2.1.1 Open-loop control systems

In an open-loop control system, the controller independently calculates exact voltage or current needed by the actuator to do the job and sends it. With this approach, however, the controller never actually knows if the actuator did what it was supposed to because there is no feedback. This system absolutely depends on the controller knowing the operating characteristics of actuator.

Open-loop control systems are appropriate in applications where the actions of the actuator on the process are very repeatable and reliable. Relays and stepper motors are devices with reliable characteristics and are usually open-loop operations. Actuators such as motors or flow valves are sometimes used in open-loop operation, but they must be calibrated and adjusted at regular intervals to ensure proper system operation.

2.1.2 Closed-Loop control systems

In a closed-loop control system, the output of the process (controlled variable) is constantly monitored by a sensor; the sensor samples the system output and converts this measurement into an electric signal that it passes back to the controller. Because the controller knows what the system is actually doing, it can

make any adjustment necessary to keep the output where it belongs. The signals from the controller to the actuator are the forward path, and the signal from the sensor to the controller is the feedback. The feedback signal is subtracted from the set point at the comparator.

The self-correcting feature of closed-loop control makes it preferable over open-loop control in many applications, despite the additional hardware required. This is because closed-loop system provides reliable, repeatable performance even when the system components themselves are not absolutely repeatable or precisely known [3].

2.2 Global System for Mobile Communications (GSM)

GSM is an acronym that stands for Global System for Mobile Communications. The original French acronym stands for Groupe Spécial Mobile. It was originally developed in 1984 as a standard for a mobile telephone system that could be used across Europe. It's now an international standard for mobile service. It offers high mobility, subscribers can easily roam worldwide and access any GSM network.

GSM is a digital cellular network. At the time the standard was developed it offered much higher capacity than the current analog systems. It also allowed for a more optimal allocation of the radio spectrum, which therefore allows for a larger number of subscribers.

GSM offers a number of services including voice communications, Short Message Service (SMS), fax, voice mail, and other supplemental services such as call forwarding and caller ID.

Currently there are several bands in use in GSM. 450 MHz, 850 MHz, 900 MHz, 1800 MHz, and 1900 MHz are the most common ones.

Some bands also have Extended GSM (EGSM) bands added to them, increasing the amount of spectrum available for each band.

GSM makes use of Frequency Division Multiple Access (FDMA) and Time Division Multiple Access (TDMA).

GSM allows for use of duplex operation. Each band has a frequency range for the uplink (cell phone to tower) and a separate range for the downlink (tower to the cell phone). The uplink is also known as the Reverse and the downlink shown in figure (2-1) is also known as the Forward. In this tutorial, I will use the terms uplink and downlink.

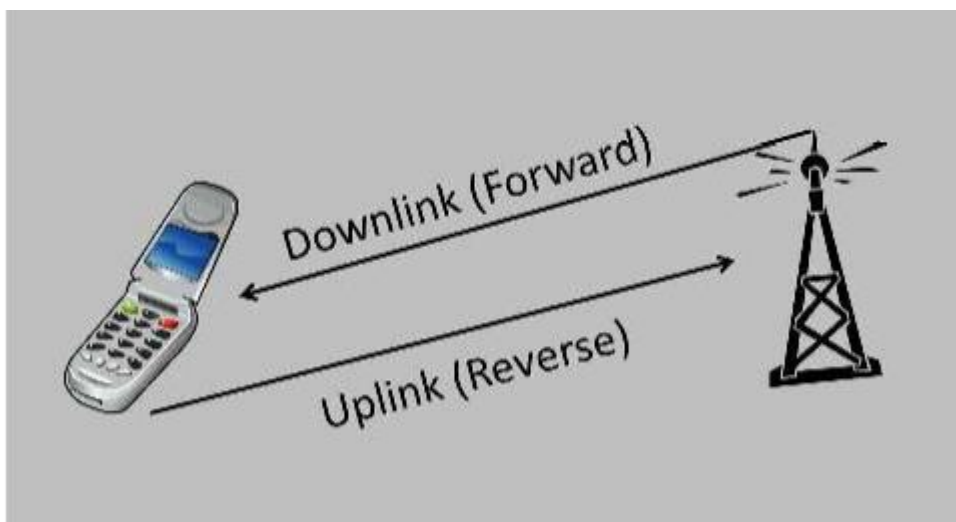

Figure (2-1): Uplink and downlink

2.3 Circuit Breaker

As a matter of fact the power system is necessary to control switch on or off whatever it was at normal condition or abnormal condition at various circuits like (transmission lines, distributors, generating plants) In earlier days switches and fuses were used to control, but there are disadvantages for using them, firstly when a fuse blows out it takes a quite sometimes to replace it secondly a fuse cannot interrupt the heavy fault current, we can conclude that the fuses and switches are limited to low voltage and small capacity circuits.

With advancement of power system the lines and equipment operate at very high voltage and carry a large currents this necessitates to employ a more dependable means of control such as it obtained by use of circuit breakers.

A circuit breaker is a piece of equipment which can make or break the circuit either manually or automatically under all conditions no-load, full-load, short-circuit this made circuit breaker very useful in switching or protection of various parts of the power system.

As we mentioned that the circuit breaker incorporates manual or remote control .the latter employs relays and operates only under fault conditions.

2.3.1 Operating principle

A circuit breaker essentially consists of fixed and moving contacts, called electrodes. These contacts remain closed and will not open automatically until and unless the system becomes faulty. Of course, the contacts can be opened manually or by remote control whenever desired. When a fault occurs on any part of the system, the trip coils of the circuit breaker get energised and the moving contacts are pulled apart by some mechanism, thus opening the circuit.

When the contacts of a circuit breaker are separated under fault conditions, an arc is struck between them. The current is thus able to continue until the discharge ceases. The production of arc not only delays the current interruption process but it also generates enormous heat which may cause damage the system or to the circuit breaker itself. Therefore extinguish the arc within the shortest possible time so that heat generated by it may not reach a dangerous value.

There are two methods of extinguishing the arc in circuit breakers the high resistance method and the low resistance or current zero method.

- **High resistance method:**

Arc resistance is made to increase with time so that current is reduced to a value insufficient to maintain the arc .the disadvantage of this method is that enormous energy is dissipated in the arc. Therefore, it is employed only in D.C circuit breakers and low-capacity A.C circuit breakers.

- **Low resistance or current zero method:**

This method is employed for arc extinction in A.C circuits only. It has small dielectric strength and can be easily broken down by the rising contact voltage.

There are important terms much used in the circuit breaker analysis

- **Arc voltage**

Appears across the contacts of the circuit breaker during the arcing period.

- **Restriking voltage**

It is a transient voltage appears across the contact at or near current zero during arc period

- **Recovery voltage**

It is the normal frequency (50 Hz) R.M.S voltage that appears across the contacts of the circuit breaker after final arc extinction it is approximately equal to the system voltage.

- **Cross-section of arc**

The arc resistance increases with the decrease in area of X-section of the arc.

Before discussing the methods of arc extinction, it is necessary to discuss the principles of arc extinction as

- P.D between the contact
- Ionised particles between the contact
- separate the contacts to such a distance that P.D becomes inadequate to maintain the arc
- The ionised particles between the contacts tend to maintain the arc. If the arc path is deionised the arc extinction will be facilitated. This may be achieved by cooling the arc or by bodily removing the ionised particles from the space between the contacts.

Classification of circuit breaker

The classification of circuit breaker depend on method of extinction used. Accordingly, circuit breakers may be classified into:

- Oil circuit breakers which employs some insulating oil for arc extinction
- Air-blast circuit breakers which use high pressure air-blast to extinguishing the arc
- Sulphur hexafluoride circuit breakers (SF₆) gas is used for arc extinction.
- Vacuum circuit breakers in which vacuum is used for arc extinction.

As we mentioned before all classifications of circuit breakers depend on isolation system but all of above method have advantages and disadvantages. In the

following section we can discuss the construction and working of these circuit breakers.

2.3.2.1 Oil circuit breakers

In this circuit breaker we use some insulating oil just as transformer oil the heat of the arc evaporates the surrounding oil and dissociates it into a substantial volume of gaseous hydrogen at high pressure .The hydrogen gas occupies a volume about one thousand times that of the oil decomposed.

The oil is, therefore, pushed away from the arc and an expanding hydrogen gas bubble surrounds the arc region and adjacent portions of the contacts. The arc extinction is facilitated mainly by two processes:

Firstly, the hydrogen gas has high heat conductivity and cools the arc, thus aiding the de-ionisation of the medium between the contacts. Secondly, the gas sets up turbulence in the oil and forces it into the space between contacts, thus eliminating the arcing products from the arc path the oil circuit breaker is shown in figure (2-2) There are advantages and disadvantages from using oil circuit breakers.



Figure (2-2): Oil circuit breaker

The advantages of using oil circuit breakers it is absorb the arc energy. Also make as insulator and allow to smaller clearance between conductors and earthed component .also the oil surrounding present cooling surface in close proximity to the arc.

The disadvantages represented on inflammable and there is a risk of a fire.

Also it may form an explosive mixture with air in addition to the arching product in the oil may cause deteriorates with successive operations.

Types of oil circuit breakers

The oil circuit breakers can be classified into two types.

- **Bulk oil circuit breakers:** which use a large quantity of oil.

The oil has to serve two purposes firstly it extinguishes the arc during opening of contacts. Secondly it insulates the current conducting parts from one another and from the earthed tank. Also this type classified into two types:

- **Plain break oil circuit breakers**

A plain-break oil circuit breaker shown in figure (2-3) involves the simple process of separating the contacts under the whole of the oil in the tank also the plain type is the earliest type from which all other circuit breakers have developed It has a very simple construction Under normal operating conditions, the fixed and moving contacts remain closed and the breaker carries the normal circuit current. When the fault occur the moving contact pulled down by the protective system and an arc is struck which the oil mainly into hydrogen gas. The arc extinction is facilitated by following terms:

Firstly the hydrogen gas bubble generated around the arc cools the arc column and aids the deionisation of the medium between the contacts secondly the gas set up turbulence in the oil and helps in clearance the arcing products from the arc path. Last but not least the arc due to the separating contacts and the dielectric strength increased.

But there are disadvantages for using plain breaker consist of:

There is no special control in arc except the increase in length by separating the moving contacts and the breakers have a long arcing time also these breakers do not permit high speed interruption due to this disadvantages plain-break oil circuit breaker used only for low voltage applications.

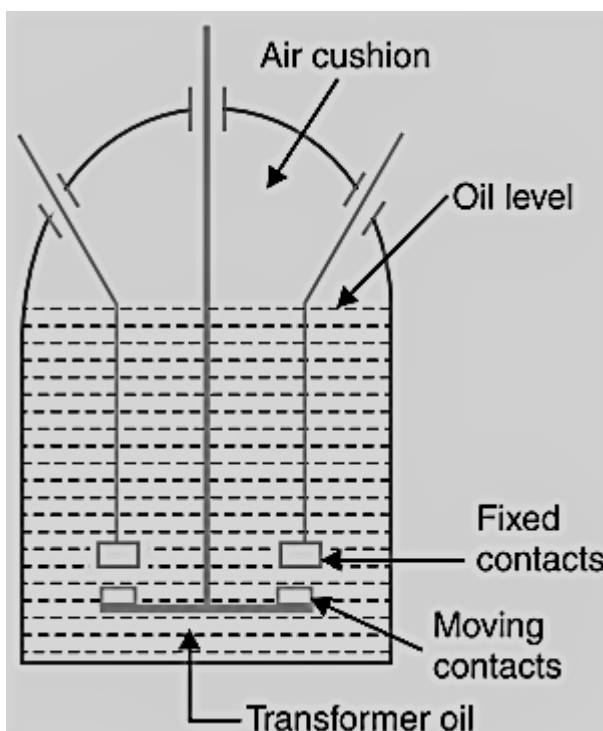

Figure (2-3): Plain break oil circuit breakers

Arc control oil circuit breakers

Comparatively long arc length is essential in order that turbulence in the oil caused by the gas may assist in cooling it. However, it is necessary and desirable that final arc extinction, should occur while the contact gap is still short. For this purpose we must use arc control circuit breakers. There are two types of such breakers, namely:

- Self-blast oil circuit breakers.
- Forced-blast oil circuit breakers.
- **Low oil circuit breakers:** shown in figure (2-4) which use less quantity of oil in such circuit breakers, oil is used only for arc extinction the oil performance has two functions firstly arc extinction and secondly insulate live part from earth. The fact that only a small percentage of oil (about 10% of total) in the bulk oil circuit

breaker is actually used for arc extinction leads to the question as to why the remainder of the oil also it should not to be omitted. That provide saving in bulk, weight and fire risk. This led us to prefer and use the low-oil circuit breakers. By using suitable arc control devices, the arc extinction can be further facilitated in a low oil circuit breaker.

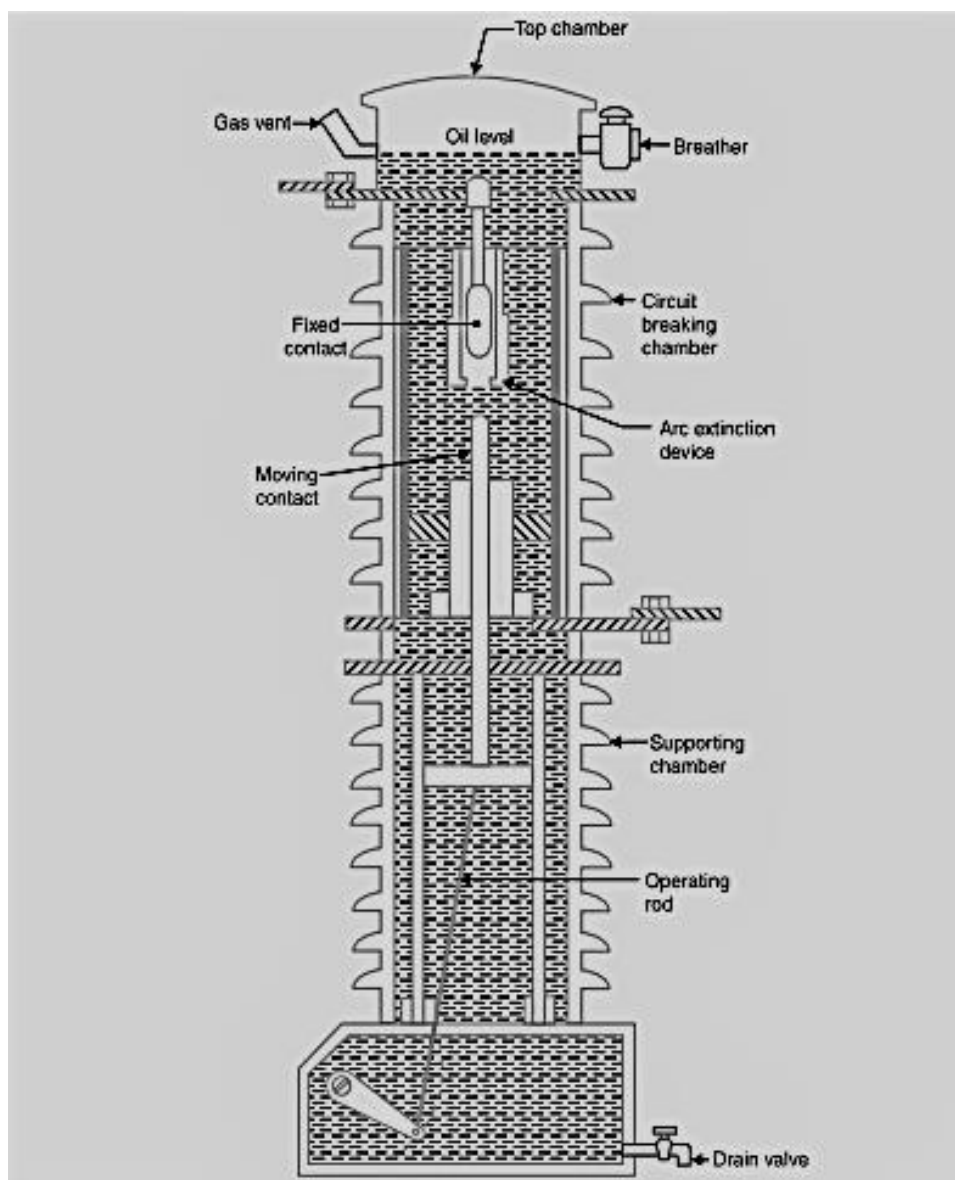

Figure (2-4): Low oil circuit breaker

There are two compartments separated from each other both filled with oil the supporting chamber it is a porcelain chamber it is filled with oil which is physically separated from the oil in the circuit breaking compartment. And circuit breaker chamber it is also filled with oil and has the following parts:

Upper and lower fixed contact in addition to moving contact and arc control device. There is another chamber called top chamber it is provide an expansion space for oil in circuit breaking compartment also provided with a separator which prevents any loss of oil by centrifugal action caused.

The upper chamber is the circuit breaking chamber while the lower one is the supporting chamber. The two chambers are separated by a partition and oil from one chamber is prevented from mixing with the other chamber. This arrangement permits two advantages firstly the circuit breaker requires less oil just enough for arc extinction Secondly, the amount of oil to be replaced is reduced as the oil in the supporting chamber does not get contaminated by the arc. A low oil circuit breaker has advantages and disadvantages. The advantages it requires a lesser quantity of oil. Also requires a smaller space than the bulk-oil circuit breakers. And it is reduced risk of fire. And maintenance problems are reduced.

The disadvantages of low oil circuit breaker compared with bulk-oil circuit breaker are these. Due to smaller quantity of oil, the degree of carbonisation is increased. Also there is a difficulty of removing the gases from the contact space in time. And the dielectric strength of the oil deteriorates rapidly due to high degree of carbonisation.

2.3.2.2 Air-blast circuit breakers

Employ a high pressure air-blast as an arc quenching medium. The contacts are opened in a flow of air-blast established by the opening of blast valve. The air blast cools the arc and the air-blast cools the arc and sweeps away the arcing products to the atmosphere. This rapidly increases the dielectric strength of the medium between contacts and prevents from re-establishing the arc. Consequently, the arc is extinguished and flow of current is interrupted.

An air blast circuit breaker has more advantages consist on that the risk of fire eliminated, the arching product are completely removed by the blast whereas oil deteriorates with successive operations; the expense of regular oil replacement is avoided, also the growth of dielectric strength is so rapid that final contact gap needed for arc extinction is very small. This reduced the size of device, also that

the arcing time is very small due to the rapid build-up of dielectric strength between contacts. Therefore, the arc energy is only a fraction of that in oil circuit breakers. Air-blast circuit breaker is appropriate where frequent operation is required. The energy supplied for arc extinction is obtained from high pressure air and is independent of the current to be interrupted.

There are three disadvantages of air-blast circuit breaker using represent on the air has relatively inferior arc extinguishing properties. Also the air-blast circuit breakers are very sensitive to the variation in the rate of rise of restriking voltage. Considerable maintenance is required for the compressor plant which supplies the air-blast.

The air blast circuit breakers are finding wide applications in high voltage installations. Majority of the circuit breakers for voltages beyond 110 kV are of this type.

Types of Air-Blast Circuit Breakers

Depending upon the direction of air-blast in relation to the arc, air-blast circuit breakers are classified into:

- **Axial blast type**

shown in figure (2-5) Shows the essential components of a typical axial-blast air circuit breaker. The fixed and moving contacts are held in the closed position by spring pressure under normal conditions. When a fault occurs, the tripping impulse causes opening of the air valve which connects the circuit breaker tank to the arcing chamber. The high pressure air entering the arcing chamber pushes away the moving contact against spring pressure. The moving contact is separated and an arc is struck. At the same time, high pressure air blast flows along the arc and takes away the ionised gases along with it. Consequently, the arc is extinguished and current flow is interrupted.

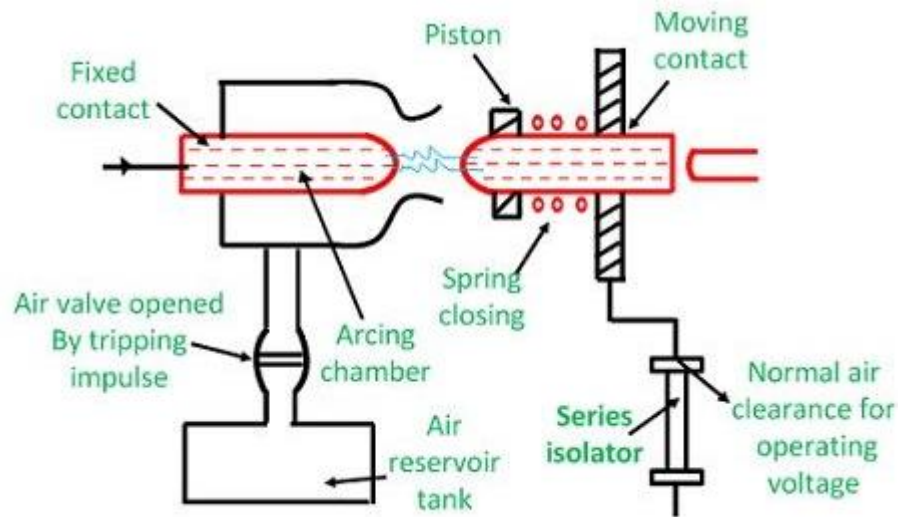

Figure (2-5): Axial blast air circuit breaker

- **Cross-blast type**

shown in figure (2-6) In this type of circuit breaker, an air-blast is directed at right angles to the arc. The cross-blast lengthens and forces the arc into a suitable slope for arc extinction. When the moving contact is withdrawn, an arc is struck between the fixed and moving contacts. The high pressure cross-blast forces the arc into a chute consisting of arc splitters and baffles. The splitters serve to increase the length of the arc and baffles give improved cooling. Also the result is that arc is extinguished and flow of current is interrupted.

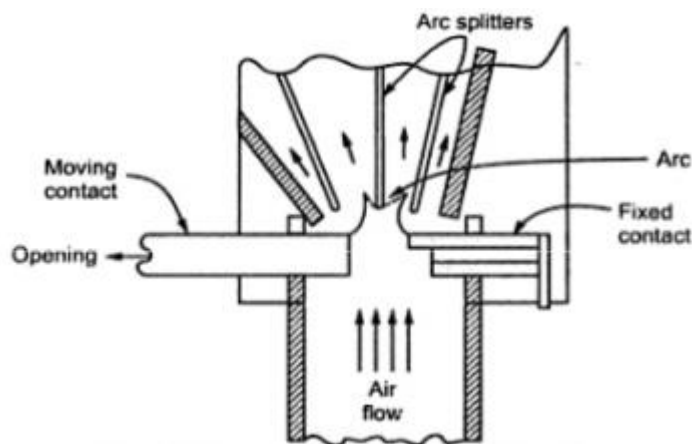

Figure (2-6): Cross blast air circuit breaker

- **Radial-blast type**

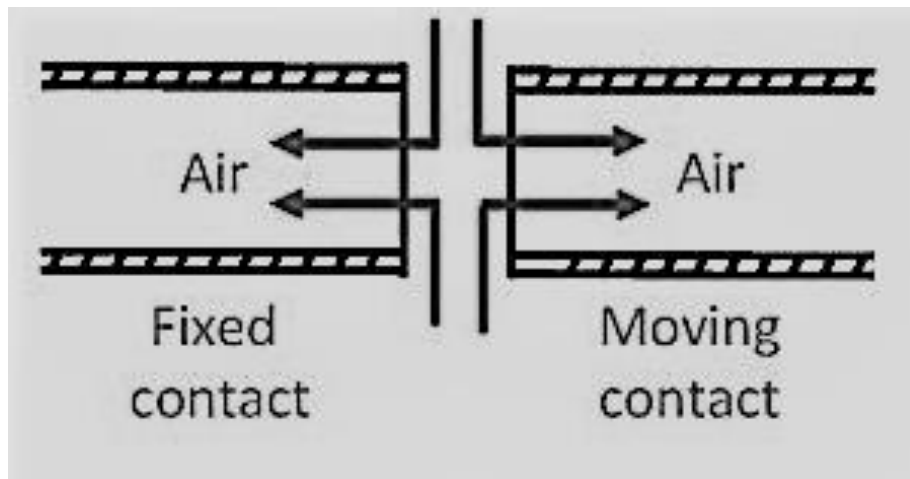

Figure (2-7): Radial blast air circuit breaker

2.3.2.3 Sulphur Hexafluoride (SF₆) Circuit Breakers

The (SF₆) is shown in figure (2-8) is an electro-negative gas and has a strong tendency to absorb free electrons. The contacts of the breaker are opened in a high pressure flow of (SF₆) gas and an arc is struck between them. The conducting free electrons in the arc are rapidly captured by the gas to form relatively static negative ions. This loss of conducting electrons in the arc quickly builds up enough insulation strength to extinguishing the arc. The (SF₆) circuit breakers have been found to be very effective for high power and high voltage service.

The (SF₆) consists of fixed and moving contacts enclosed in a chamber (called arc interruption chamber) containing SF₆ gas.

This chamber is connected to (SF₆) gas reservoir. When the contacts of breaker are opened, the valve mechanism permits a high pressure (SF₆) gas from the reservoir to flow towards the arc interruption chamber. The fixed contact is a hollow cylindrical current carrying contact fitted with an arc coupling.

The moving contact is also a hollow cylinder with rectangular holes in the sides to permit the (SF₆) gas to let out through these holes after flowing along and across the arc. The tips of fixed contact, moving contact and arcing horn are painted with copper-tungsten arc resistant material. Since SF₆ gas is costly, it is

reconditioned and reclaimed by suitable auxiliary system after each operation of the breaker.

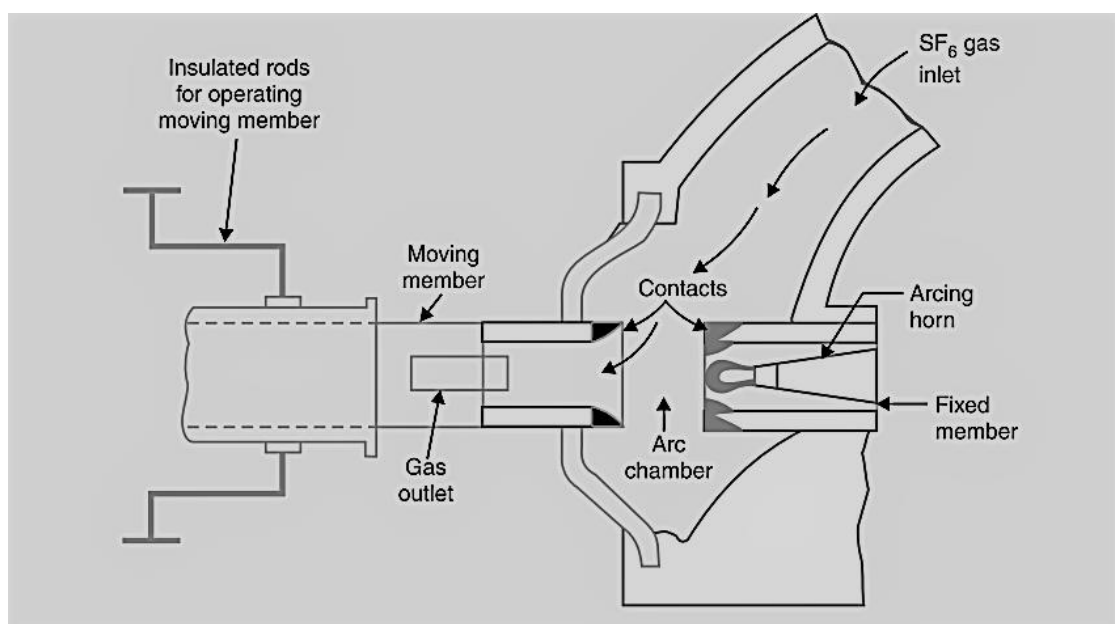

Figure (2-8): Sulphur Hexafluoride (SF6) Circuit Breaker

Operation

In the closed position of the breaker, the contacts remain surrounded by SF6 gas at a pressure of about 2.8 kg/cm². When the breaker operates, the moving contact is pulled apart and an arc is struck between the contacts. The movement of the moving contact is synchronised with the opening of a valve which permits SF6 gas at 14 kg/cm² pressure from the reservoir to the arc interruption chamber. The high pressure flow of SF6 rapidly absorbs the free electrons in the arc path to form immobile negative ions which are ineffective as charge carriers. The result is that the medium between the contacts quickly builds up high dielectric strength and causes the extinction of the arc. After the breaker operation. The SF6 circuit breakers have many advantages over oil or air circuit breakers. Some of them are listed below:

- Have very short arcing time.
- Since the dielectric strength of SF6 gas is 2 to 3 times that of air, such breakers can interrupt much larger currents.

- The SF6 circuit breaker gives noiseless operation due to its closed gas circuit and no exhaust. To atmosphere unlike the air blast circuit breaker.
- The closed gas enclosure keeps the interior dry so that there is no moisture problem.
- There is no risk of fire in such breakers because SF6 gas is non inflammable.
- There are no carbon deposits so that tracking and insulation problems are eliminated.
- The (SF6) breakers have low maintenance cost, light foundation requirements and minimum auxiliary equipment.
- Since (SF6) breakers are totally enclosed and sealed from atmosphere, they are particularly suitable where explosion hazard exists.

(SF6) have two disadvantages it considered costly due to high cost of (SF6), and Since SF6 gas has to be reconditioned after every operation of the breaker, additional equipment is required for this purpose.

Applications

A typical SF6 circuit breaker consists of interrupter units each capable of dealing with currents up to 60 kA and voltages in the range of 50—80 kV. A number of units are connected in series according to the system voltage. SF6 circuit breakers have been developed for voltages 115 kV to 230 kV, power ratings 10 MVA to 20 MVA and interrupting time less than 3 cycles.

2.3.2.4 Vacuum Circuit Breakers

shown in figure (2-9) In such breakers, vacuum (degree of vacuum being in the range from 10^{-7} to 10^{-5} torr) is used as the arc quenching medium.

Since vacuum offers the highest insulating strength, it has far superior arc quenching properties than any other medium. For example, when contacts of a breaker are opened in vacuum, the interruption occurs at first current zero with dielectric strength between the contacts building up at a rate thousands of times higher than that obtained with other circuit breakers.

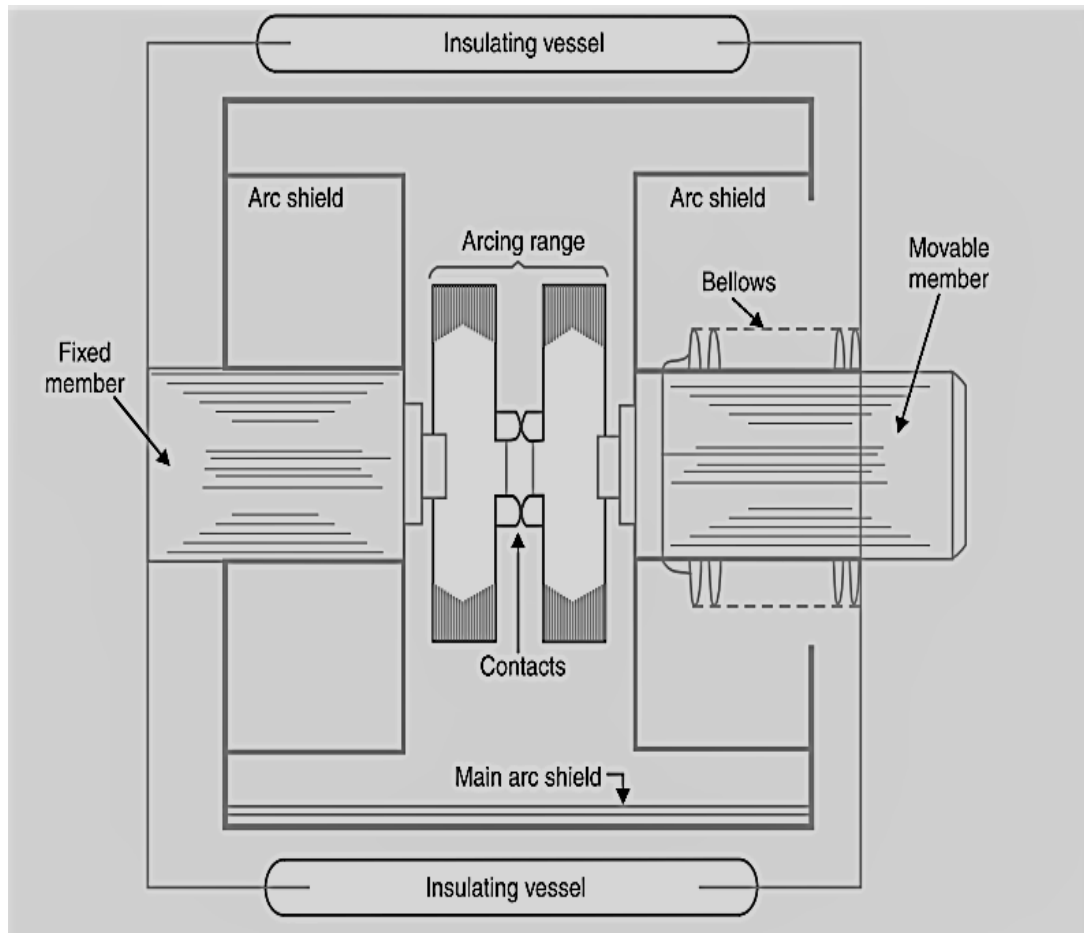

Figure (2-9): Vacuum circuit breaker

The production of arc in a vacuum circuit breaker and its extinction can be explained as follows:

When the contacts of the breaker are opened in vacuum an arc is produced between the contacts. However, the arc is quickly extinguished because the metallic vapours, electrons and ions produced during arc rapidly condense on the surfaces of the circuit breaker contacts, resulting in quick recovery of dielectric strength. As soon as the arc is produced in vacuum, it is quickly extinguished due to the fast rate of recovery of dielectric strength in vacuum.

Vacuum circuit breaker consists of fixed contact, moving contact and arc shield mounted inside a vacuum chamber. The movable member is connected to the control mechanism by stainless steel bellows. This enables the permanent sealing of the vacuum chamber so as to eliminate the possibility of leak. A glass vessel or ceramic vessel is used as the outer insulating body. The arc shield

prevents the deterioration of the internal dielectric strength by preventing metallic vapours falling on the inside surface of the outer insulating cover.

When the breaker operates, the moving contact separates from the fixed contact and an arc is struck between the contacts. The production of arc is due to the ionisation of metal ions and depends very much upon the material of contacts. The arc is quickly extinguished because the metallic vapours, electrons and ions produced during arc are diffused in a short time and seized by the surfaces of moving and fixed members and shields. Since vacuum has very fast rate of recovery of dielectric strength, the arc extinction in a vacuum breaker occurs with a short contact separation (say 0.625 cm). Vacuum circuit breakers have the following advantages:

- Compact, reliable and have longer life.
- No fire hazards.
- No generation of gas during or after operation.
- Can interrupt any fault current.
- Require little maintenance, and are quite in operation.
- Can successfully withstand lightning surges.
- Have low arc energy.
- Have low inertia and hence require smaller power for control mechanism.

Application of vacuum circuit breaker: For a country like India, where distances are quite large and accessibility to remote areas difficult, the installation of such outdoor, maintenance free circuit breakers should prove a definite advantage. Vacuum circuit breakers are being employed for outdoor applications ranging from 22 kV to 66 kV. Even with limited rating of say 60 to 100 MVA, they are suitable for a majority of applications in rural areas [1].

2.4 Microcontroller

A microcontroller is a single-chip computer. Micro suggests that the device is small, and controller suggests that it is used in control applications. Another term for microcontroller is embedded controller, since most of the microcontrollers are built into or embedded in the devices that controlling.

Microcontrollers have traditionally been programmed using the assembly language of the target device. Although the assembly language is fast, it has several disadvantages. An assembly program consists of mnemonics, which makes learning and maintaining a program written using the assembly language difficult. Also, microcontrollers manufactured by different firms have different assembly languages, so the user must learn a new language with every new microcontroller he or she uses. Microcontrollers can also be programmed using a high-level language, such as BASIC, PASCAL, or C. High-level languages are much easier to learn than assembly languages and also facilitate the development of large and Complex programs.

Microcontroller is a highly integrated chip that contains Central Processing Unit (CPU), Random Access Memory (RAM), Read Only Memory (ROM) and Input/output I/O ports. Unlike general-purpose computer, which also includes all of these components, microcontroller is designed for a 9 very specific task to control a particular system. As a result, the parts can be simplified and reduced, which cuts down on production cost.

2.4.1 Microcontroller components

A microcontroller basically contains one or more following components:

- Central processing unit

Central Processing Unit is the brain of a microcontroller. CPU is responsible for fetching the instruction, decodes it, and then finally executed. CPU connects every part of a microcontroller into a single system. The primary function of CPU is fetching and decoding instructions. Instruction fetched from program memory must be decoded by the CPU.

- Memory

Memory in a microcontroller is same as microprocessor. It is used to store data and program. A microcontroller usually has a certain amount of RAM and ROM (EEPROM, EPROM, etc.) or flash memories for storing program source codes.

- Parallel input/output ports

Parallel input/output ports are mainly used to drive/interface various devices such as LCD'S, LED'S, printers, memories, etc. to a microcontroller.

- Serial interfacing ports

Serial ports provide various serial interfaces between microcontroller and other peripherals like parallel ports.

- Timers and counters

This is the one of the useful function of a microcontroller. A microcontroller may have more than one timer and counters. The timers and counters provide all timing and counting functions inside the microcontroller. The major operations of this section are perform clock functions, modulations, pulse generations, frequency measuring, making oscillations, etc. This also can be used for counting external pulses.

- Analog to digital converter

Analog to Digital Converter (ADC) converters are used for converting the analog signal to digital form. The input signal in this converter should be in analog form (e.g. sensor output) and the output from this unit is in digital form.

The digital output can be used for various digital applications (e.g. measurement devices).

- **Digital to analog converter**

Digital to Analog Converter (DAC) perform reversal operation of ADC conversion. DAC convert the digital signal into analog format. It usually used for controlling analog devices like DC motors, various drives, etc.

- **Interrupt control**

The interrupt control used for providing interrupt (delay) for a working program. The interrupt may be external (activated by using interrupt pin) or internal (by using interrupt instruction during programming).

- **Special functioning block**

Some microcontrollers used only for some special applications (e.g. space systems and robotics) these controllers containing additional ports to perform such special operations. This considered as special functioning block [4].

2.5 Relays

Protective relaying is one of the several features of the power system design. Every part of the power system is protected. The factors affecting the choice of protection are type and rating of equipment []. In a power system consisting of generators, transformers, transmission and distribution circuits, it is inevitable that sooner or later some failure will occur somewhere in the system when a failure occurs on any part of the system, it must be quickly detected and disconnected from the system. There are two principal reasons for it. Firstly, if the fault is not cleared quickly, it may cause unnecessary interruption of service to the customers. Secondly, rapid disconnection of faulted apparatus limits the amount of damage to it and prevents the effects of fault from spreading into the system. The detection of a fault and disconnection of a faulty section or apparatus can be achieved by using fuses or relays in conjunction with circuit breakers. A fuse performs both detection and interruption functions automatically but its use is limited for the protection of low-voltage circuits only. For high voltage circuits (say above 3.3 kV), relays and circuit breakers are employed to serve the desired function of automatic protective gear. The relays detect the fault and supply information to the circuit breaker which performs the function of circuit interruption.

Protective relays

A protective relay it is a device that detect the fault and initiates the operation of the circuit breaker to isolate the defective element from the rest of the system. The relays detect the abnormal conditions in the electrical circuits by constantly measuring the electrical quantities which are different under normal and fault conditions. The electrical quantities which may change under fault conditions are voltage, current, frequency and phase angle. Through the changes in one or more of these quantities, the faults signal their presence, type and location to the protective relays. Having detected the fault, the relay operates to close the trip circuit of the breaker. This results in the opening of the breaker and disconnection of the faulty circuit. A typical relay circuit is shown in Fig. (2-10) .This diagram shows one phase of 3-phase system for simplicity.

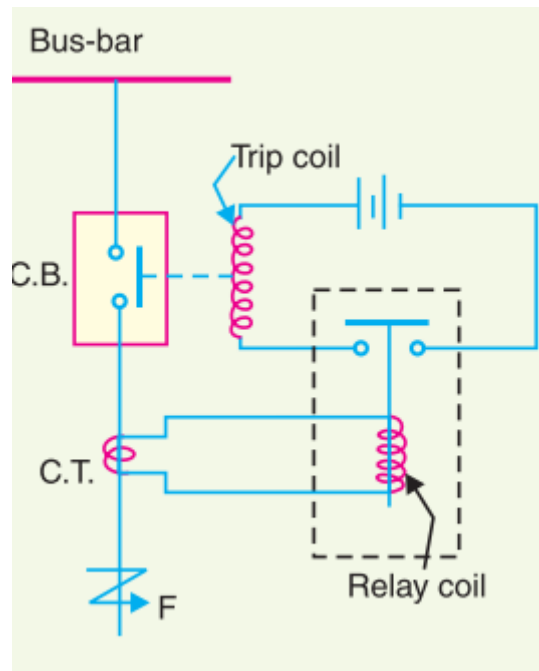

Figure (2-10): The relay

A relay is a function of the volt-amperes input to the coil of the relay necessary to cause its operation. The smaller the volt-ampere input required to cause relay operation, the more sensitive is the relay. Thus, a 1 VA relay is more sensitive than a 3 VA relay. It is desirable that relay system should be sensitive so that it operates with low values of volt-ampere input. Most of the relays in service on electric power system today are of electro-mechanical type. They work of operating principles of Electromagnetic attraction relays operate by virtue of an armature being attracted to the poles of an electromagnet or a plunger being drawn into a solenoid. Such relays may be actuated by DC or AC quantities [1].

CHAPTER THREE

SYSTEM HARDWARE AND SOFTWARE CONSIDERATION

3.1 Using transistors as a switch

Transistors can do an exceptional number of tasks, you can use a single transistor to make a simple electrically controlled switch. Every transistor has a three pins, the emitter and collector and base.

Current flows in through the collector and out of the emitter. By modulating the base pin, you can control whether current is permitted to flow. When a sufficiently high voltage is applied to the base, current is allowed to flow through the transistor, and the motor spins as a result. The 5V generated by the Arduino I/O pins more than suffices to turn on the transistor [2].

3.2 Arduino

Arduino is a small microcontroller board shown in figure (3-1) with a USB plug to connect to your computer and a number of connection sockets that can be wired up to external electronics, such as motors, relays, light sensors, laser diodes, loudspeakers, microphones, etc. Arduino can either be powered through the USB connection from the computer or from a 9V battery, Arduino can be controlled from the computer or programmed by the computer and then disconnected and allowed to work independently [2].

The hardware consists of an open source hardware board that is designed around the Atmel AVR Microcontroller. The intention of Arduino was to make the application of interactive components or environments more accessible. Arduino is programmed via an Integrated Development Environment (IDE)

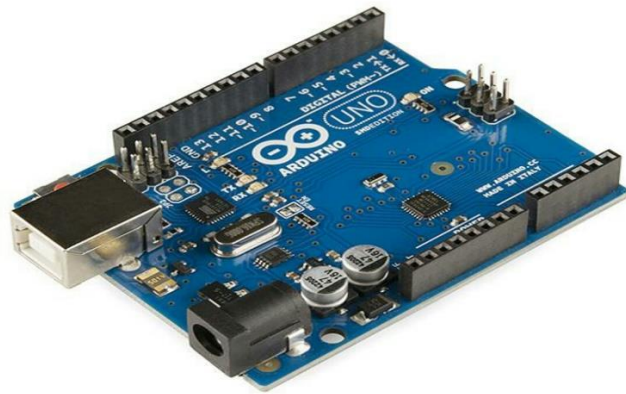

Figure (3-1): Arduino board

and run on any platform that supports Java like LABVIEW. An Arduino program is written in either C or C++ and is programmed using its own IDE.

3.3 Relay interfacing with arduino

It is electromechanical device shown in figure (3-2). It contains a solenoid coil and some kind of mechanical assembly. When a coil is magnetised by apply its operating voltage it get magnetising and changes the position of a switch. And the connected device will be ON or OFF depending on the connection.

A relay is used to switch ON and OFF the AC appliances. It also provides an isolation between arduino that running at 5V and AC appliances running at 220V AC.

It has COM (common), NC (normally close) and NO (normally open) terminal.

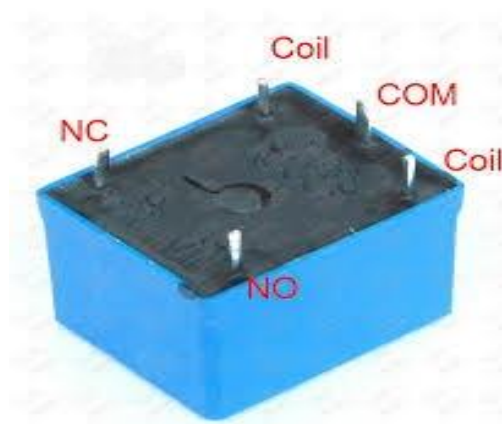

Figure (3-2): Relay point

A simple transistorised circuit is enough to drive the relay. Here NPN transistor works as a switch. Giving a high signal to its base conduct it and energises the relay coil and connection from COM-NC to COM-NO is done.

3.4 Setting up the LCD

A parallel LCD screen These are extremely common and come in all kinds of shapes and sizes. The most common is a 16×2 character display with a single row of 16 pins (14 if it does not have a backlight). In this topic, we use a 16-pin LCD display that can show a total of 32 characters (16 columns and 2 rows).

If your display didn't come with a 16-pin header already soldered on, you need to solder one on so that you can easily install it in your breadboard. With the header successfully soldered on, your LCD should look like the one shown in Figure (3-3).

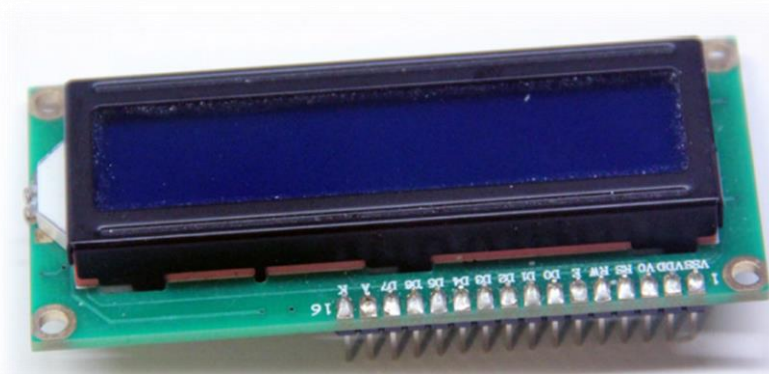

Figure (3-3): LCD with headers soldered on

And you can insert it into your breadboard. Next, you wire up your LCD to a breadboard and to your Arduino. All of these parallel LCD modules have the same pin-out and can be wired in one of two modes: 4-pin or 8-pin mode. You can accomplish everything you might want to do using just 4 pins for communication; that's how you'll wire it up. There are also pins for enabling the display, setting the display to command mode or character mode, and for setting it to read/write mode.

Table (1): the parallel LCD pins

Pin number	Pin name	Pin purpose
1	VSS	Ground connection
2	VDD	+5V connection
3	V0	Contrast adjustment(to potentiometer)
4	RS	Register selection (Character vs. Command)
5	RW	Read/write
6	EN	Enable
7	D0	Data line 0 (unused)
8	D1	Data line 1 (unused)
9	D2	Data line 2 (unused)
10	D3	Data line 3 (unused)
11	D4	Data line 4
12	D5	Data line 5
13	D6	Data line 6
14	D7	Data line 7
15	A	Backlight anode
16	K	Backlight cathode

3.5 Interface the keypad to Arduino

A keypad is one of the most commonly used input devices in microprocessor applications shown in figure (3-4). In a standard keypad wired as an X-Y switch matrix, normally-open connect a row to a column when pressed.

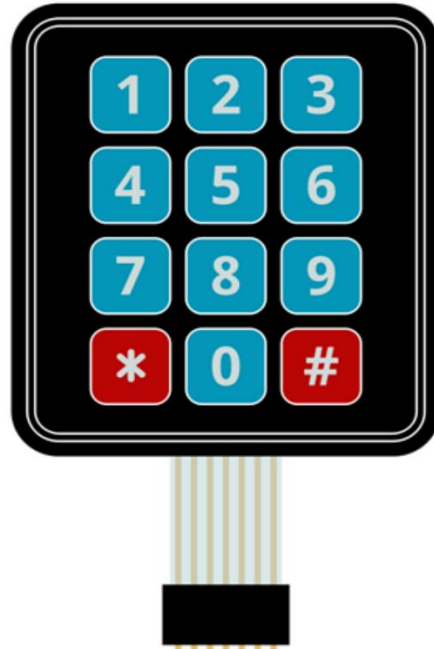

Figure (3-4): 3×4 Hex keypad

The internal structure and pin notation is shown as in the following figure (3-5):

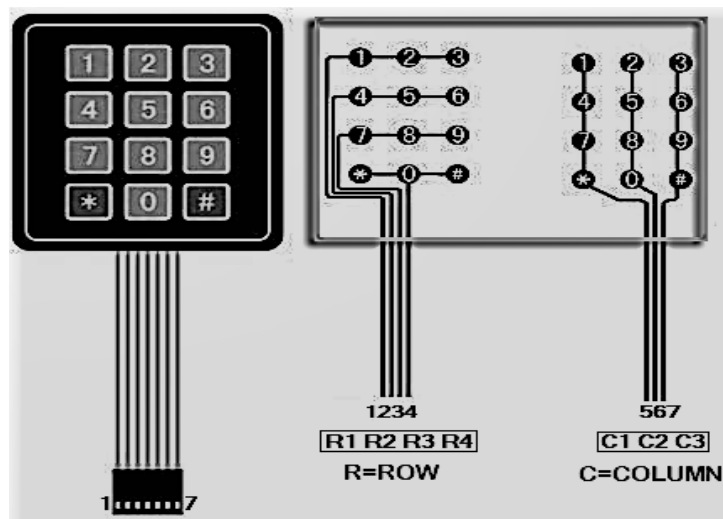

Figure (3-5): Internal structure and pin notation

3.6 Gsm module interfacing with arduino

shown in figure (3-6) There are two ways of connecting GSM module to Arduino. In any case, the communication between Arduino and GSM module is serial. So we are supposed to use serial pins of Arduino (Rx and Tx). You may connect the (Tx) pin of GSM module to (Rx) pin of Arduino and (Rx) pin of GSM module to (Tx) pin of Arduino. Also connect the ground pin of Arduino to ground pin of GSM module.

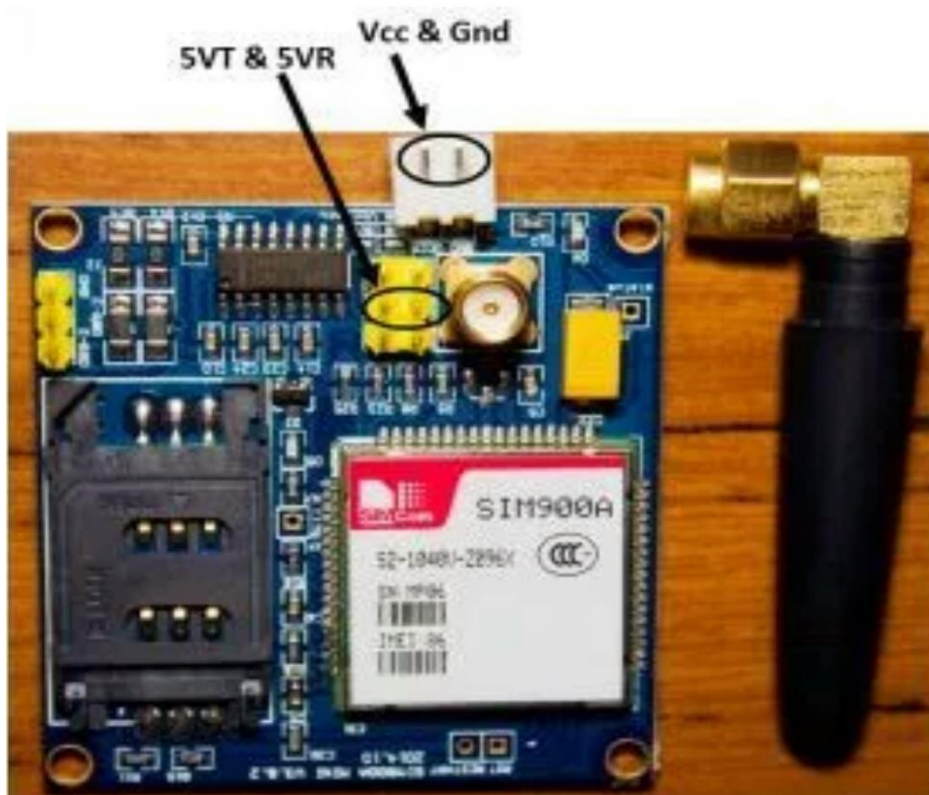

Figure (3-6): SIM900A GSM module

But the problem with this connection is that, while programming Arduino uses serial ports to load program from the Arduino IDE. If these pins are used in wiring, the program will not be loaded successfully to Arduino. So you have to disconnect wiring in Rx and TX each time you burn the program to Arduino. Once the program is loaded successfully, you can reconnect these pins and have the system working, to avoid this difficulty, we must be using an alternate method in which two digital pins of Arduino are used for serial communication.

We need to select two PWM enabled pins of Arduino for this method. So we choose pins 2 and 3 (which are PWM enabled pins). This method is made possible with the SoftwareSerial Library of Arduino. Software Serial is a library of Arduino which enables serial data communication through other digital pins of Arduino. The library replicates hardware functions and handles the task of serial communication.

3.6 block diagram

shown in figure (3-7). Describes how to control in relay contacts with a common signal (input) from keypad to the controller and the result appear on LCD screen, the relay does not change its contacts unless a common signal comes from the GSM module that represents an SMS to the controller or signal from keypad. GSM module will activate in case of receiving a signal from keypad.

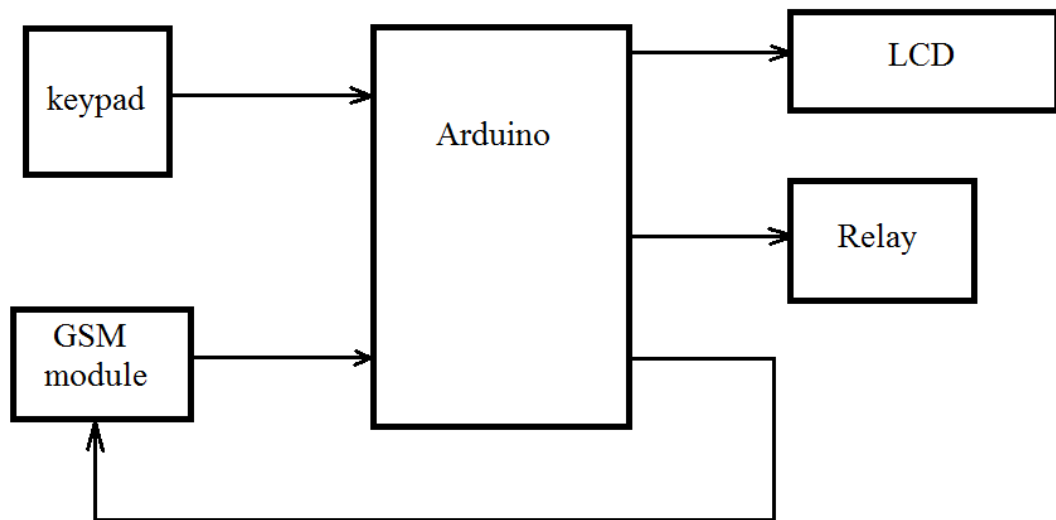

Figure (3-7) Block diagram

3.6 Wire diagram

Wire diagram is shown in figure (3-8) is network of wires showing how to connect the circuit components, it explains the signals requirement for the movability and the ON-OFF control, also it declare the power feeding lines for the circuit. Wire diagram describe how all wires connected between the system circuit components. Wire diagram shown below explain (shows) that the connections between the pins of controller and the other components that represent on (LCD screen, keypad, transistor, alarm, GSM module). Also shows the connection of relay contacts.

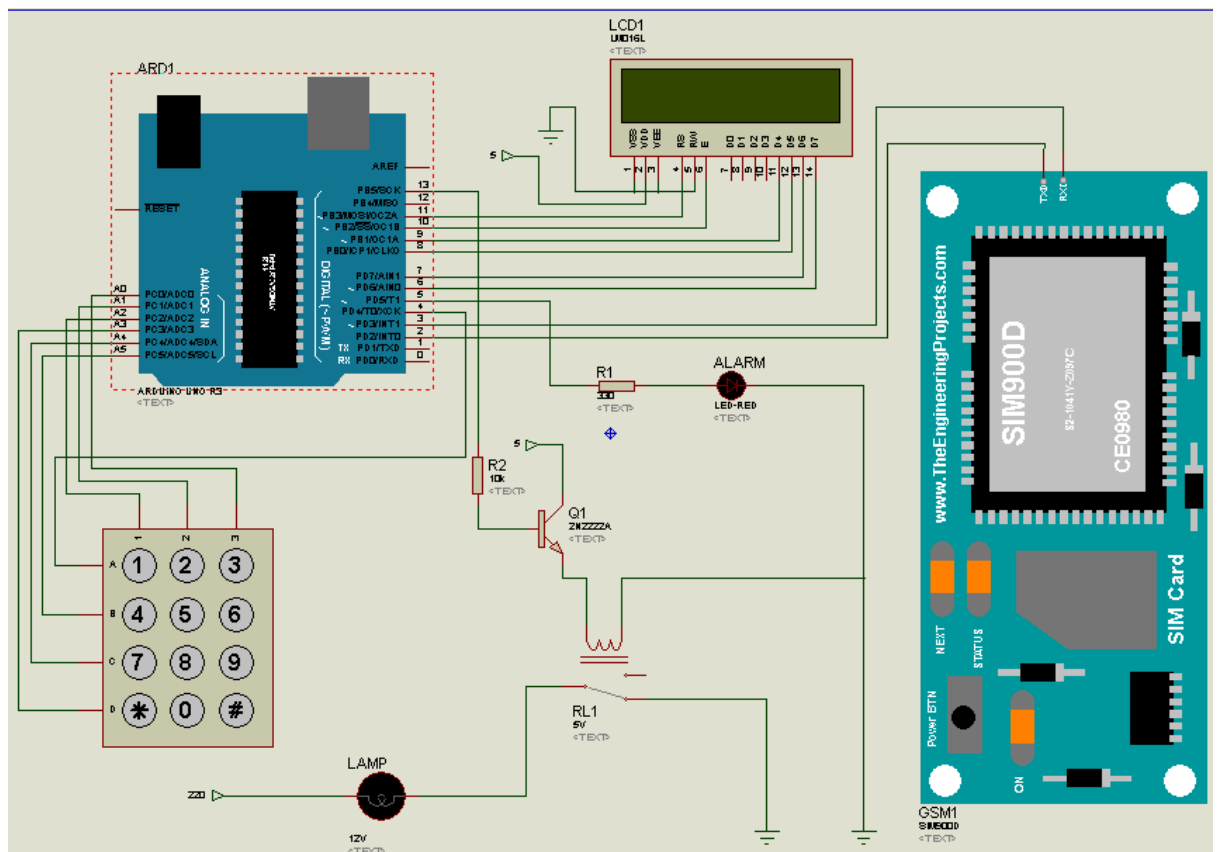

Figure (3-8): Wire diagram

CHAPTER FOUR

SYSTEM IMPLEMENTATION AND TESTING

4.1 System Implementation

A circuit breaker that based on a password contain of a LCD screen and keypad and a relay with a load also GSM module were collected together and installed as described steps below:

The program of circuit breaker password written on arduino software and .hex file created.

The code shown in appendix upload by help of USB cable from arduino application to arduino board, and the diagram is connected shown in figure (4-1).

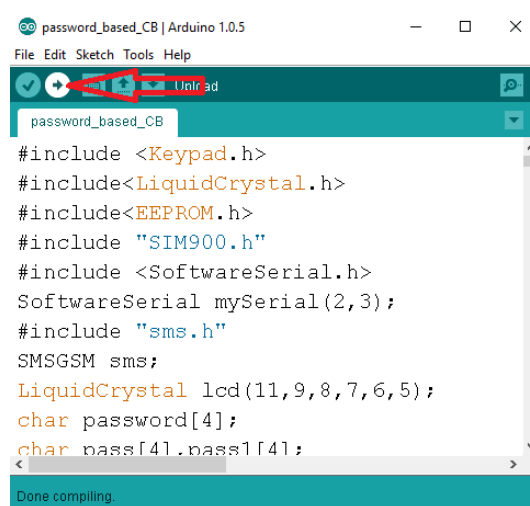

```
password_based_CB | Arduino 1.0.5
File Edit Sketch Tools Help
password_based_CB
#include <Keypad.h>
#include<LiquidCrystal.h>
#include<EEPROM.h>
#include "SIM900.h"
#include <SoftwareSerial.h>
SoftwareSerial mySerial(2,3);
#include "sms.h"
MSGSMS sms;
LiquidCrystal lcd(11,9,8,7,6,5);
char password[4];
char pass[4],pass1[4];
Done compiling.
```

Figure (4-1):upload the code

A 5 volt DC supplies used to the controller. Also DC and AC supplies switched on that means we have about 230 volt on relay output, so do not touch the load shown in figure (4-2).

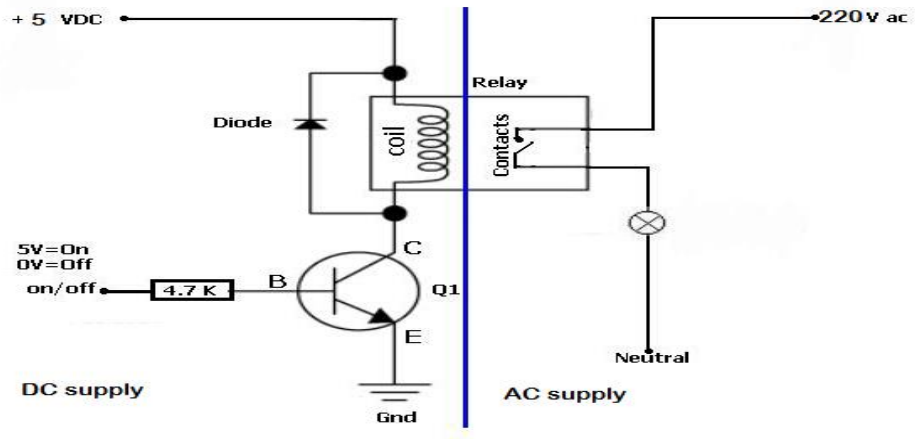

Figure (4-2):DC and AC supplies

LCD displays “Enter the password” that with a help of keypad shown in figure (4-3).

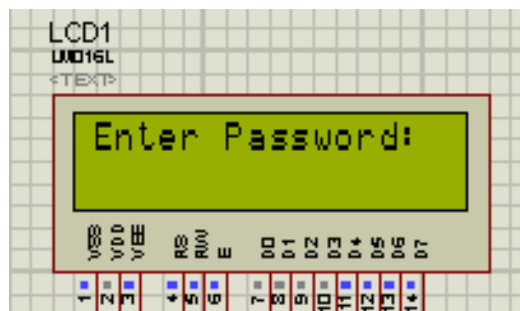

Figure (4-3): Entering the password

You can see on LCD screen the same number that you entered by keypad to get sure about the number that you should shown in figure (4-4).



Figure (4-4): Appearance of password in LCD

Now, if the password is correct LCD shows that “accepted password” and at same time the pulse make the contacts of relay changes, but if password that

you entered is wrong “wrong password” will appear on LCD screen and there is alarm will activate shown in figure (4-5).

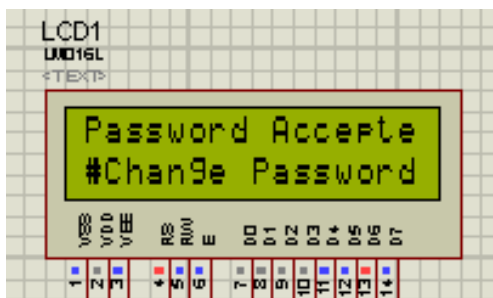

Figure (4-5): Accept the correct password

It is not a certain password, a user can change the password by entered the bottom ‘#’ the program ask you to enter the old password and seriously the new password that you choose shown in figure (4-6).

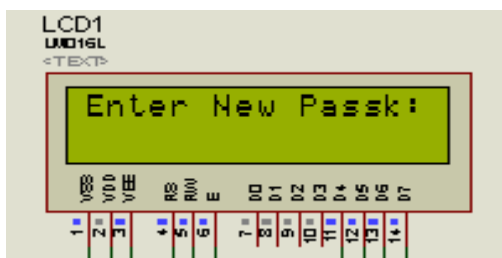
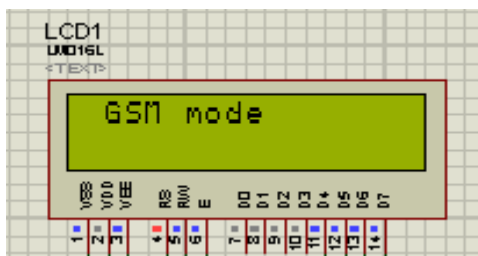

Figure (4-6): Change of password

In case of entering the bottom ‘*’ the LCD shows “GSM mode” in this case keypad is not work, there is only on way to control on system and that by sending the write password on SMS message to the number of SD card that used. The same result from a keypad using will occurs in case of correct password or not.



Figure(4-7): GSM mode

4.2 The practical circuit

The figures (4-8) and (4-9) shown the practical circuit in normal and after detach condition.

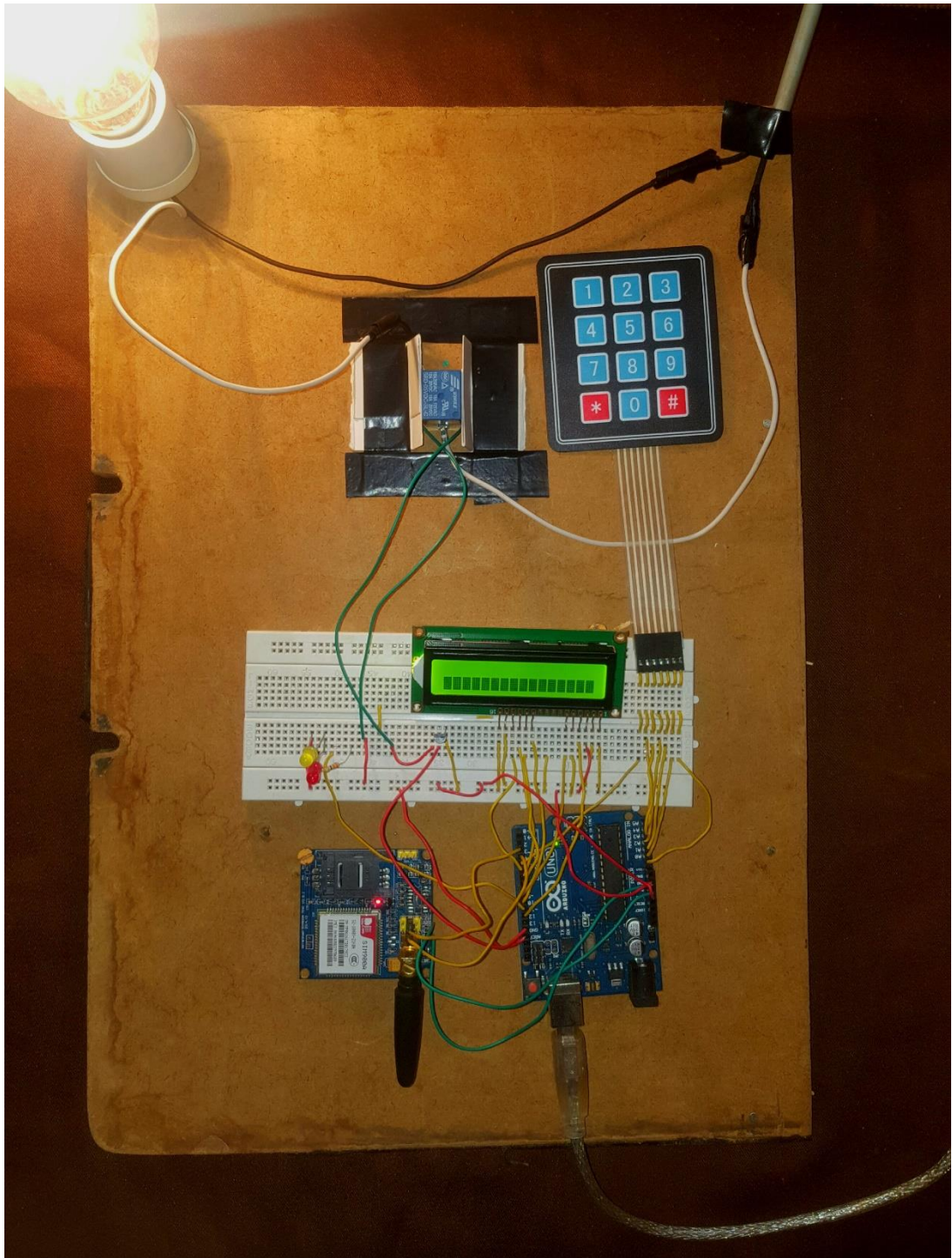
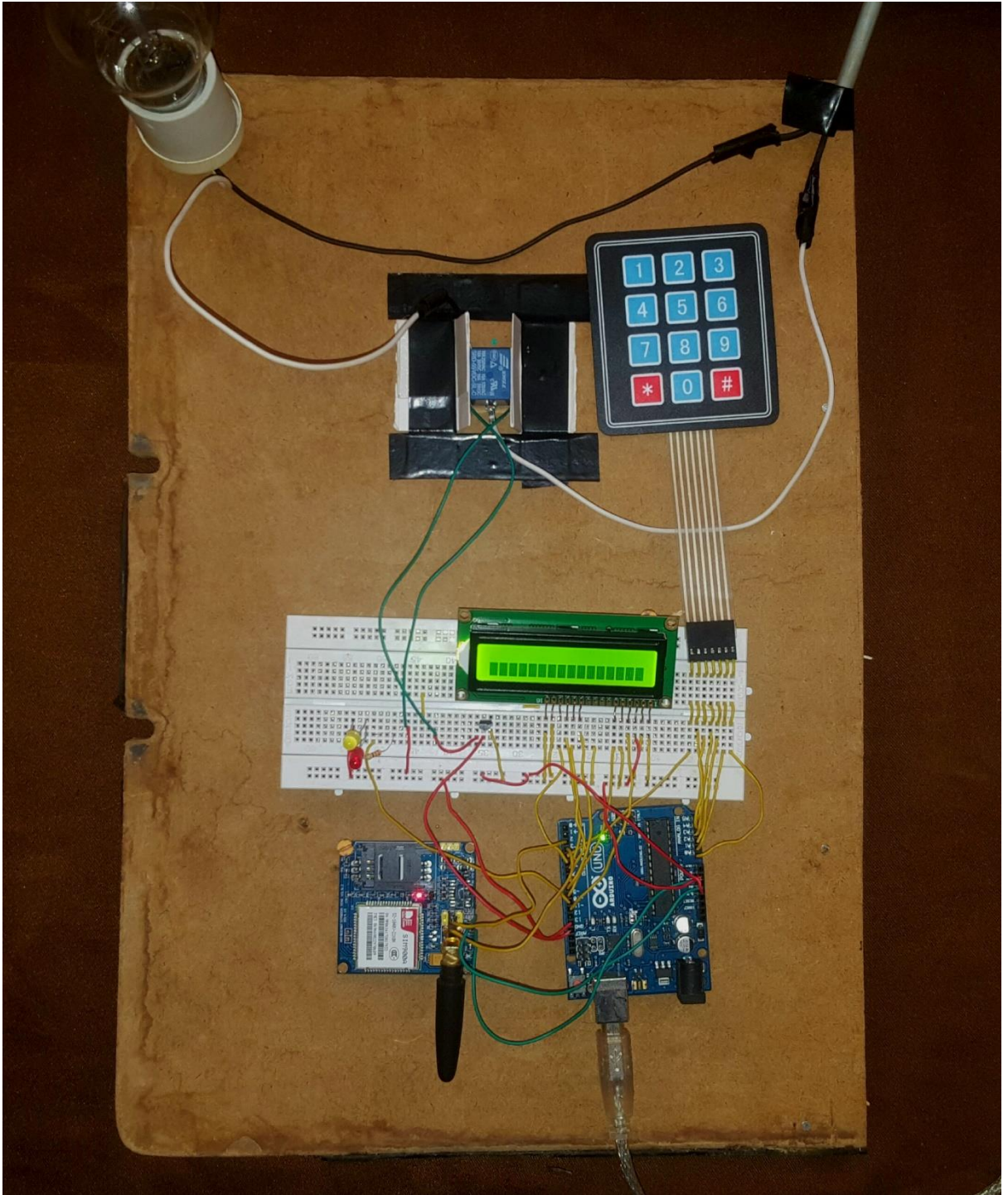

Figure (4-8): The practical circuit in normal condition



Figure(4-9): The practical circuit after detach condition

CHAPTER FIVE

CONCLUSION AND RECOMMENDATIONS

5.1 Conclusion

A perfect protection has been achieved to line man, in whilst of increase of line man accident that happens while repairing the electrical lines due to the lack of communication between electrical substation and maintenance staff nowadays. Finally protective system has given to line man protection.

The solve of this problem clarified on using a password to turn ON/OFF circuit breaker. It is not a teaser to turn OFF circuit breaker the issue is that to turn ON circuit breaker whilst line man on a task that may cause a fire , blast , burning , also we can't ignore the damage that may cause burning the station this lead to financial losses.

The needle of turn off circuit breaker has represented on adding a buses to station or to treating (lines, transformers, generators ... etc). The manual part is using the keypad to entering password that will appear on LCD screen to be absolute about that you enter the password you preselected. The password will store on Arduino's EEPROM and the output is to rotate a motor that separate a moving contact and break the circuit. Here a safety has provided to the line man because the moving contact will not move unless we entering the same password that line man select. In addition to alarm that has made in case that some one try to turn ON circuit breaker after he entering a wrong circuit breaker.

By using a global system mobile (GSM) an extra feature has gained represented on gaining time just the line man has to send the same password he selected before in a message and the breaker will restart the circuit. of the above a multi features have introduced to power system generally and particular electrical protection system is to provide electrical protection from risk, burning, and gain time.

5.2 Recommendations

When we implemented to this project some obstacle appeared most of all solved, and little of it remained, therefor a lot of space for further improvement.

- The controller can receive a message only from a certain number that actually must be saved in the wizard include the password this will give a more security, no one can try to send a random password from any number because the controller does not receive any message from any number except the number that saved in the wizard.
- Another feature can be added in nameable of reducing cost by use only one controller to control in many relays that depend on adjusting just on code.

REFERENCES:-

[1] V.K Mehta, "**Principle of power system**", S. Chand, 2005.

[2] Wiley, "**Exploring Arduino**", Tools and Techniques for Engineering Wizardry, india, 2013.

[3] Christopher kilian, "**Modern control technology**", Cengage Learning, 2005.

[4] Gunther Gridling, Bettina Weiss, "**Introduction to microcontroller**" , in Vienna University of Technology, 2007.

APPENDIX

*Arduino code:

```
#include <Keypad.h>

#include<LiquidCrystal.h>

#include<EEPROM.h>

#include "SIM900.h"

#include <SoftwareSerial.h>

SoftwareSerial mySerial(2,3);

#include "sms.h"

MSGSM sms;

LiquidCrystal lcd(11,9,8,7,6,5);

char password[4];

char pass[4],pass1[4];

int i=0;

char customKey=0;

const byte ROWS = 4; //four rows

const byte COLS = 3; //three columns

char hexaKeys[ROWS][COLS] = {

  {'1','2','3'},

  {'4','5','6'},

  {'7','8','9'},

  {'*','0','#'}}
```

```

};

byte rowPins[ROWS] = {4,A5,A4,A3}; // the row pinouts of the keypad

byte colPins[COLS] = {A2,A1,A0}; // the column pinouts of the keypad

Keypad customKeypad = Keypad( makeKeymap(hexaKeys), rowPins, colPins,
ROWS, COLS);

int buzzer = 10;

int m13=13;

int k=1;

int numdata;

boolean started=false;

char smsbuffer[160];

char n[20];

void setup()

{

  Serial.begin(9600); //Serial connection

  delay(2000);

  if (gsm.begin(9600)){

    lcd.print("READY");

    delay(1000);

    started=true;

  }

  else Serial.println("\nstatus=IDLE");

  if(started){

```

```

//Enable this two lines if you want to send an SMS.

//if (sms.SendSMS("3471234567", "Arduino SMS"))

    //Serial.println("\nSMS sent OK");

}

lcd.begin(16,2);

pinMode(led, OUTPUT);

pinMode(buzzer, OUTPUT);

pinMode(m2,OUTPUT);

pinMode(m13,OUTPUT);

lcd.print(" Electronic ");

lcd.setCursor(0,1);

lcd.print(" Keypad Lock ");

delay(2000);

lcd.clear();

lcd.print("Enter Password:");

lcd.setCursor(0,1);

for(int j=0;j<4;j++)

EEPROM.write(j, j+49);

for(int j=0;j<4;j++)

pass[j]=EEPROM.read(j);

}

void loop()

{

```

```

customKey = customKeypad.getKey();

if(customKey=='*' && k==2){

  lcd.print(" GSM module");

  gsmmm();

  }

if(customKey=='#')

  change();

if (customKey){

  password[i++]=customKey;

  lcd.print(customKey);

}

if(i==4){

  delay(200);

  for(int j=0;j<4;j++)

    pass[j]=EEPROM.read(j);

  if(!(strcmp(password, pass,4))){

    digitalWrite(led, HIGH);

    lcd.clear();

    lcd.print("Password Accepted");

    delay(2000);

    if(k==1){

      digitalWrite(m13,HIGH);

      k++;

```

```
    }  
    else{  
        digitalWrite(m13,LOW);  
        k--;  
    }  
    lcd.setCursor(0,1);  
    lcd.print("#Change Password");  
    delay(2000);  
    lcd.clear();  
    lcd.print("Enter Password:");  
    lcd.setCursor(0,1);  
    i=0;  
}  
else{  
    digitalWrite(buzzer, HIGH);  
    lcd.clear();  
    lcd.print(" Access Denied...");  
    lcd.setCursor(0,1);  
    lcd.print("#Change Password");  
    delay(2000);  
    lcd.clear();  
    lcd.print("Enter Password:");  
    lcd.setCursor(0,1);
```

```

        i=0;

        digitalWrite(buzzer, LOW);

    }}}

void change()

{

    int j=0;

    lcd.clear();

    lcd.print("Current Password");

    lcd.setCursor(0,1);

    while(j<4){

        char key=customKeypad.getKey();

        if(key){

            pass1[j++]=key;

            lcd.print(key);

        }

        key=0;

    }

    delay(500);

    if((strcmp(pass1, pass, 4))){

        lcd.clear();

        lcd.print("Wrong Password..");

        lcd.setCursor(0,1);

        lcd.print("Better Luck Again");

```



```

    delay(1000);

}

else{

    j=0;

    lcd.clear();

    lcd.print("Enter New Passk:");

    lcd.setCursor(0,1);

    while(j<4){

        char key=customKeypad.getKey();

        if(key){

            pass[j]=key;

            lcd.print(key);

            EEPROM.write(j,key);

            j++;

        }

        lcd.print(" Done.....");

        delay(1000);

    }

    lcd.clear();

    lcd.print("Enter Ur Passk:");

    lcd.setCursor(0,1);

    customKey=0;

}

```

```

void gsmmm ()
{
while(k){
    if(started){
        //Read if there are messages on SIM card and print them.
        if(gsm.readSMS(smsbuffer, 160, n, 20)){
            Serial.println(n);
            Serial.println(smsbuffer);
            if(!(strcmp(smsbuffer, pass,4)))
            {
                digitalWrite(m13,LOW);
                k--;
                customKey=0;
                lcd.print("Enter password");
                break;
            }
            else{
                if(!(strcmp(smsbuffer,"off",3))){
                    customKey=0;
                    break;
                }
            }
            else{
                Serial.println("wrong pass");
            }
        }
    }
}

```

```
mySerial.println("AT+CMGF=1"); //the GSM Module in Text Mode
delay(1000); // Delay of 1000 milli seconds or 1 second
mySerial.println("AT+CMGS=\"00249900671917\"\r");
delay(1000);
mySerial.println("wrong password");// The SMS text you want to send
delay(100);
mySerial.println((char)26);// ASCII code of CTRL+Z
delay(1000);
}}}}}}
```