

## Control of Wind Turbine for Variable Speed Based on Fuzzy-PID Controller

Omer Abbaker Ahmed, Dr. Ahmed Awad Ahmed

Department Of Electrical Engineering, Karary University, Khartoum, Sudan

Received: 22/08/2016

Accepted: 12/10/2016

**ABSTRACT**-Nyala is one of the most suitable areas in Sudan for building wind energy conversion system. This system could be linked with Nyala electrical grid without expensive cost because it is near to the electrical local grid. The permanent changes of wind speed with no stable mode generate different amplitude and frequency voltages which differ from Nyala electrical grid utility parameters. This requires good and suitable controller to facilitate the link process or direct connection to the load. This paper proposes a fuzzy-PID controller as maximum power point tracker (MPPT) to track the maximum power available from the wind energy conversion system (WECS) and to obtain AC voltage with constant amplitude and frequency. The maximum power is obtained based on the rotor speed of the wind turbine which represent in error between actual rotor speed of PMSG and estimated value of rotor speed depend on values of DC current and voltage at the terminal of boost-converter and parameters of PMSG. The error of rotor speed is given as input to the fuzzy-PID controller that controls the duty cycle of pulse width modulation (PWM) generator and its output is connected to the boost converter. The proper wind turbine with its generator was chosen depending on parameters of probability density function (pdf), called Weibull Function. To validate the correctness and effectiveness of the proposed system, it is simulated with MATLAB/SIMULINK model. The simulation results show the good performance of the proposed control scheme.

**Keywords:** Wind turbine, Permanent Magnet Synchronous Generator (PMSG), Maximum power point tracking (MPPT), PWM, PID and Fuzzy logic controller.

المستخلص-تعد منطقة نيالا من اكثر المناطق في السودان ملائمة لإنشاء نظام تحويل طاقة رياح , يمكن ربطها بالشبكة المحلية لمدينة نيالا بدون تكاليف كبيرة نظرا لقرب المنطقة من الشبكة , لكن تغير سرعات الرياح الدائم و عدم استقراريتها يؤدي الى توليد جهود مختلفة في التردد و المطال على خرج النظام مما يتطلب استخدام نظام تحكم جيد و مناسب ليسهل عملية الربط مع الشبكة او ربطها مباشرة مع الحمل . يهدف هذه الورقة الى تصميم نظام تحويل طاقة رياح ملائم مع منطقة نيالا و التحكم به بحيث نحصل دائما على جهد و تردد ثابتين و مطابقين لجهد و تردد الشبكة , و ذلك اعتمادا على المكونات الالكترونية و استخدام نظام التحكم الهجينى مكون من متحكم المنطق الضبابي و متحكم التناسبي التكاملي التفاضلي كمتتبع للقدرة القصوى التي يتم استخراجها من من منظومة التوليد , فان نظام التحكم يعتمد على الخطأ بين سرعة المولد و القيمة المقدره لها والذي يعتمد على ثوابت المولد و قيمة التيار و الجهد المستمر على طرف محول الجهد المستمر , ويكون الخطأ دخل لمنظومة التحكم . تم اختيار التوربينه الهوائية الملائمة للمنطقة اعتمادا على بارامترات كثافة دالة الاحتمال الرياضي يسمى دالة وايبل . تم تصميم نظام التحكم لتتبع أقصى قدرة مستخرجة من نظام الرياح و مطابقة خرج النظام من الجهد و التردد مع الشبكة (415V-50Hz) . للتأكد من صحة و صلاحية و فعالية النظام المقترح تمت نمذجته و محاكاته باستخدام برنامج MATLAB/SIMULINK , و قد أظهرت نتائج المحاكاة اداء منظومة التحكم يتمثل في إمكانية الحصول على جهد و تردد ثابتين لا يتغيران نتيجة تغير سرعة الرياح .

## INTRODUCTION

Sudan is one of countries where many sources of renewable energies are available such as wind, solar and so on, specifically in northern part (Dongla), east part (Port Sudan) and west part (Nyala). The average of wind speeds in those areas varies between 7 – 8 m/s [1]. The investment of such renewable resources in the process of conversion into other forms of energy, such as electric energy, is supporting the country in many energy forms, will have great impacts on the country economy, and help in having good and clean environment.

According to the forecasts, it is expected that by 2050 global demand for energy grows up to 3 times [2]. At least 15 to 20 percent of global energy demand will be met directly by new and renewable energy sources. The wind energy is considered one of these sources. The use of Wind energy is on the rise because it is clean, but the truth about wind power is that wind energy is expensive and for economic use, it is necessary to minimize the occurrence of errors in it. Production of nuclear and fossil power and other energies which are harmful for the environment, peace and human welfare, must be replaced with better methods. It means that they should turn into the form of available renewable energy in the environment. The various types of renewable energy sources contributing to current energy demand consist of water, wind, solar energy and biomass [3].

Many new technologies such as pitch control and variable speed control methods have been tested and put forward since then. Sometimes, wind turbine work in an isolating mode; therefore, there is no grid. Usually there are two, three or even more than three blades on a wind turbine. However according to aerodynamics concept, three blades is the optimum number of blades for a wind turbine [4]. Asynchronous and synchronous AC machines are the main generators that are used in the wind turbines.

A wind turbine extracts kinetic energy from the wind and converts this into mechanical energy. Then, this mechanical energy is converted to electrical energy with the help of a generator. Therefore, the complete system that involves converting the energy of the wind to electricity is called wind energy conversion system. A wind turbine extracts the maximum amount of energy from the wind when operating at an optimal rotor speed, which again depends on speed of wind. The optimal rotor speed varies due to the variable nature of the wind speed. Wind power is the most reliable

and quick developing among the various renewable energy sources. Wind turbines can operate both in fixed as well as variable speed operation mode. For a fixed speed operation the generator is directly connected to grid whereas for variable speed the generator is controlled with the help of power electronic equipment. Therefore double fed induction generator plays a vital role by operating in grid as well as in standalone mode [3,4,5].

There are different control methods and strategies of wind turbine generation proposed and discussed in the literature review:

Akash Alex Paret [6] presented a PID Controller Frequency regulation of Wind Turbine using Matlab/Simulink software, the output frequency of a wind turbine system supplying an isolated load is regulated by controlling the rotor speed, The gains of the PID controller are tuned using manual tuning and design optimization toolbox.

Vishal T. [7], presented a PID Controller Based Pitch Actuator System for Variable speed horizontal axis wind turbine using MATLAB, that is used to control the aerodynamic power of wind turbine. He observed The values of time response parameters ( $K_p$ ,  $K_i$  and  $K_d$ ) of the pitch actuator system for different cases, to give suitable tuning for the response.

Saravanakumar and Rajendran [8], proposed a nonlinear approach to wind turbine (WT) using two-mass model, a combination of linear and nonlinear controllers is adapted to variable speed variable pitch wind turbines (VSVPWT) system, a controller is used to maximize the energy capture from the wind with reduced oscillation on the drive train at varying wind speed.

Rupendra Kumar [9], presented various mechanical control methods used for controlling wind turbine (WT), and their role in WT power generating stations such as the gear control, blade pitch angle control and yaw control, for fluctuating wind speed, they proposed simplified methodology for gear design to obtain the speed of driven gear in a practical case.

Sachin Khajuria [10], presented how the control of variable speed wind turbine can be used to generate a fixed value of voltage at the output with the help of a PI controller. This is done by varying the pitch angle of the blades. Pitch angle control is used for adjusting the aerodynamic torque of the wind turbine when wind speed is above rated speed and various controlling variables may be chosen, such as wind speed, generator speed and generator power. The model is simulated by Matlab/Simulink software package.

Luis Alberto Torres Salomao [11], suggested a fuzzy logic proportional integral (Fuzzy PI) control

design for a 1.5 MW horizontal axis wind turbine. Design of the proposed Fuzzy PI control algorithm is achieved by tuning with the Ziegler-Nichols approach at low and nominal wind speeds. The fuzzy section selects the desired PI gains according to wind speed with a smooth control transition by using MATLAB/SIMULINK.

Umesh Kumar Soni [12], presented a (PID) control of pitch angle of rotor blades with an internal pitch loop. That is investigated for different reference value of rpm and wind speeds ranging from 6-12 m/s .The model is simulated using MATLAB/SIMULINK.

HamedHabibi [13], proposed an adaptive fuzzy controller that is employed in full load operation.

Here in this work, a scheme to control the designed WT system dedicated to operating in Nyala region is proposed. This scheme consists of a PID controller aided with a fuzzy logic one.

**A. Wind Data Analysis and Parameters Extraction**

According to data collected from Nyala area for the wind speeds, which recorded during the specified period as given in table 1, it is found that the mean value of wind speed is equal 7m/s.

Table 1: represents the average of wind speeds three times monthly for 8 months

Months	Mean of wind speeds m/s		
	Beginning	Mid	End
JANUARY	11.755	10.754	9.922
FEBRAURY	8.512	8.950	9.898
MARCH	7.700	9.030	6.200
ABRIL	7.521	8.790	6.090
MAY	5.940	6.730	6.210
JUNE	3.690	5.570	5.100
JULY	3.500	6.710	5.400
AUGUST	3.850	6.400	3.830

$$\bar{u} = 1/n \sum_{i=1}^n u_i(1)$$

$$\sigma^2 = \frac{1}{n-1} \sum_{i=1}^n (u_i - \bar{u})^2 \quad (2)$$

Where:

n: number of measured values

$\bar{u}$ : Average or arithmetic mean

$u_i$ : A set of measured wind speeds

$\sigma$ : The standard deviation.

Depending on equation (1) and equation (2) for the arithmetic mean and standard deviation respectively, the mean speed is found to be 7 m/s and the standard deviation is 2.312.

**B. Design Procedure of Wind turbine**

It is well known in the literature that, the speeds of wind in most areas of the world fit the probability density function of Weibull [20,21,22,23]gives evidence that the distribution of wind speeds in Sudan is also comply with the Weibull distribution. See Figure 1

The process of selecting the suitable wind turbine parameters depends on two parameters according to the Weibull distribution which is given by:

$$f(u) = \frac{k}{c} \left(\frac{u}{c}\right)^{k-1} e^{-\left(\frac{u}{c}\right)^k} (3)$$

Where: c and k are the scale parameter and the shape parameter respectively. The scale parameter is directly proportional to the mean of wind speed.

$$c = 1.12 \bar{u} (4)$$

$$k = \left(\frac{\sigma}{\bar{u}}\right)^{-1.086} (5)$$

The maximum energy obtained from any one wind speed is :

$$W_{max} = \frac{1}{2} \rho A u_{me}^3 f(u_{me}) (8760) (6)$$

The Rated wind speed is equal :

$$u_{me} = \left(\frac{k+2}{k}\right)^{1/k} \text{ m/s } (7)$$

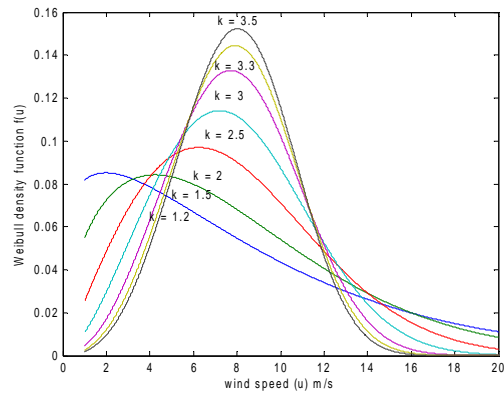

Figure 1: Weibull density function f(u)

We determine the rated wind speed  $u_m$  at which both the wind turbine and the generator can operate at their maximum efficiencies. This wind speed would be somewhere between the cut-in and rated wind speeds of the turbine so the generator can operate around its maximum efficiency point for a good range of wind speeds[14].

Table 2: the summary of all parameters of weibull function

Parameter	The value
Average of wind speed m/s	7
Standart deviation	2.312
Scale factor	7.84
Shape factor	3.33
Rated wind speed m/s	9

### C. Wind Energy Conversion System and Control

Figure 2 shows the block diagram for the proposed Wind Energy Conversion System (WECS) with fuzzy-PID controller. The proposed WECS unit consists of PMSG which is connected to uncontrolled rectifier. The dc-dc boost converter is used to catch the maximum power from the wind. The fuzzy-PID is exploited as MPPT controller. In the fuzzy controller one input is given which manipulates the error between the actual rotor speed and the estimated speed. The output of the fuzzy-PID controller is connected to PWM generator which generates pulses with variable duty cycle and constant frequency to control the boost converter. The Voltage Source Inverter (VSI) is controlled only using PWM generator to obtain output AC voltage with constant amplitude and frequency depending on the setting of PWM generator. The proposed system is designed and simulated in the MATLAB/SIMULINK.

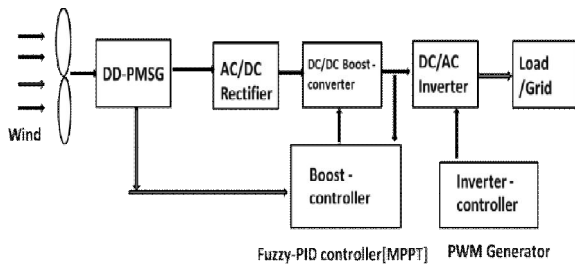

Figure 2: block diagram of proposed system

### D. Model of the Wind Turbine

The tip speed ratio  $\lambda$  is defined as the ratio between the speed of the tips of the blades of a wind turbine and the speed of the wind [2].

$$\lambda = \frac{\omega_m R}{V} \quad (8)$$

Where:

$\omega_m$ : is the angular velocity of the rotor

$R$ : the rotor radius (blade length).

$V$ : The wind speed.

The area covered by the blades is given by:

$$A = \pi \cdot R^2 \quad (9)$$

The power in the air can be computed as

$$P_W = \frac{1}{2} \rho \cdot A \cdot V^3 \quad (10)$$

$\rho$  = Air density

The power extracted from the wind is given by:

$$P_{blaed} = C_p \cdot P_W \quad (11)$$

$$P_{blaed} = \frac{1}{2} C_p \cdot \rho \cdot A \cdot V^3 \quad (12)$$

The rotor torque  $T_m$  can be computed as:

$$T_m = \frac{P_{blaed}}{\omega_m} = \frac{\frac{1}{2} C_p \cdot \rho \cdot A \cdot V^3}{\omega_m} \quad (13)$$

The power coefficient  $C_p$  can be defined as a function of the tip-speed ratio and the blade pitch angle as follows:

$$C_p = C_1 \cdot \left[ C_2 \cdot \frac{1}{\gamma} - C_3 \beta - C_4 \cdot \beta^x - C_5 \right] e^{-C_6 \frac{1}{\gamma}} \quad (14)$$

Where:  $\beta$  is a pitch angle

With  $\gamma$  defined as:

$$\frac{1}{\gamma} = \frac{1}{\lambda + 0.08\beta} - \frac{0.035}{1 + \beta^3} \quad (15)$$

According to mathematical equations of wind turbine (8-15), and using parameters given in table 3 we can get the curves that describe the behavior of power coefficient vs. tip-speed ratio for the WT, as depicted in Figure 3,4, and 5.

Table 3: The wind turbine parameters used for the proposed system

Parameters	Values
Rotor radius, $R$	28 m
Air density, $\rho$	1.225 kg/m <sup>3</sup>
Aerodynamic coefficients, $c_1$ - $c_6$	$c_1=0.5, c_2=116, c_3=0.4, c_4=0, c_5=5, c_6=21$
the angular velocity of the rotor $\omega_m$	2.25 rad/s
Rotation speed	24.4 rpm
Cut-in wind speed	3 m/s
Rated wind speed	9m/s
Cut-out wind speed	22 m/s

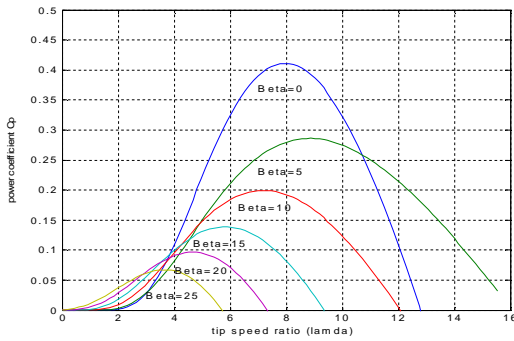

Figure 3: power coefficient  $C_p$  and tip speed ratio

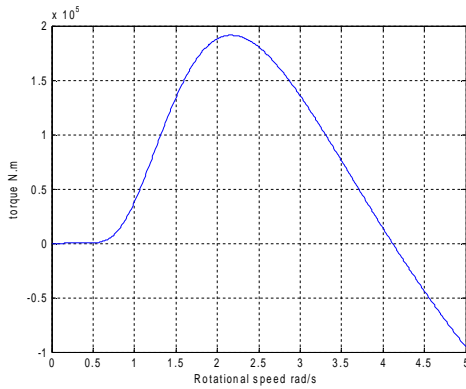

Figure 4: torque(N) and rotational speed (rad/s)

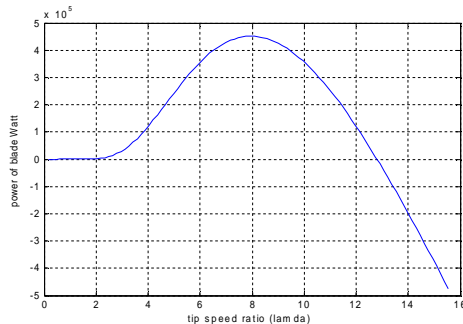

Figure 5: Mechanical power (W) vs. tip - speedratio  $\lambda$

### E. DC/DC Boost- converter

The DC-to-DC converters are often used in regulated switch-mode dc power supplies and in dc motor drives applications. Frequently, the input to this converter is an unregulated dc voltage which can be obtained by rectifying an AC voltage source. This unregulated voltage will fluctuate due to changes in the line. In order to control this unregulated dc voltage into a regulated DC output we need to use a DC-to-DC. In this model, the boost converter has been controlled to yield constant output DC voltage level,  $V_{dc2}$  by varying the duty cycle,  $D$  in response to variations in  $V_{dc1}$ . Figure 6 shows the components of Boost-converter that represented by the MOSFET transistor or IGBT/diode, diode, inductor(L) and capacitor(C).The design of this DC/DC converter depend on the chosen values of the (L and C) and operating frequency of the transistor [15].

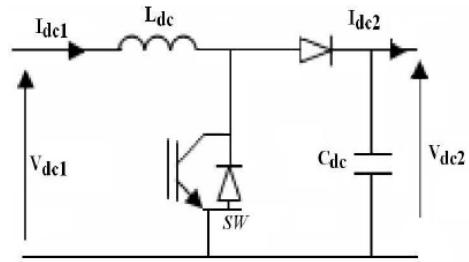

Figure 6: Boost (DC-DC) converter

The relation between the input and output voltage and currents of the boost converter is expressed by the following equations

$$V_{dc2} = \frac{1}{(1-D)} V_{dc1} \quad (16)$$

$$I_{dc2} = (1 - D) I_{dc1} \quad (17)$$

where  $D$  is "on" mode connection of duty cycle

The inductor  $L$ , is selected using [15]

$$L \geq \frac{V_o * T_s}{2 * I_o(crit)} * \frac{V_i(max)}{V_o - V_i(max)} \quad (18)$$

Where :

$V_o$ : is output voltage of the boost converter

$T_s$ : is time of duty cycle for control signal.

$V_i(max)$ : is maximum of the input voltage.

$I_o(crit)$ : is minimum output current that required for system of Continues Conduction Mode.

$$I_o(crit) = \frac{\Delta I}{2} \quad (19)$$

$\Delta I$  has ratio between (10% -30%).

The capacitor  $C$  is selected according to [15]

$$C \geq \frac{I_o(max) * D_{max}}{f_s * \Delta V_o} \quad (20)$$

$$I_o(max) = \frac{1-D}{D} * I_{in(max)} \quad (21)$$

$$D_{max} = \frac{V_o}{V_o + V_i(min)} \quad (22)$$

$I_{O(max)}$  (A) is maximum of output current for boost-converter.

$D_{max}$  is maximum ratio of transistor connection.

$\Delta V_O$  (V) is taken value (1%).

in this work the value of DC-voltage across terminal of boost-converter is (620 V),

$I_{O(crit)}$  is (1.2A) for  $\Delta I$  30% of input current,

$T_s$  is 1/300Hz (0.33ms),  $I_{O(max)}$  is (8.5A),

$D_{max}$  is 0.7 for  $V_{i(min)}$  (80V).

### F. Filter design

The capacitor and inductor values are calculated according to following equations [24]

$$L_f = \frac{V_d}{4 * f_s * \Delta i} \quad (23)$$

$$C_f = \frac{\Delta i}{8 * f_s * \Delta V_O} \quad (24)$$

Where:

$V_d$  (V) is DC input voltage for inverter.

$\Delta i$  (A) is taken ratio between (10%-20%).

$f_s$  (Hz) is working frequency for inverter.

$\Delta V_O$  (V) is taken ratio 1%.

In this work the value of DC-voltage across terminal of boost-converter is (620 V). Input current to inverter is (6 A),  $\Delta i$  is 20% of input current (1.2A).

$f_s$  is (2000 Hz) and  $\Delta V_O$  is (6.2V).

### G. Boost-converter controller

Generator speed of PMSG can be estimated by measuring the average output voltage  $V_d$  and current  $I_d$  of the uncontrolled bridge rectifier and by knowing the parameters of selected PMSG to operate with the WT, which are given in Table 5. The relation among generator speed, PMSG parameters,  $V_d$  and  $I_d$  is governed by the following equation [19].

$$\omega_g = \frac{2\pi I (V_d + 2R_s I_d)}{60 \left[ \frac{3\sqrt{3}}{\pi} k_m - \frac{p}{2} L_s L_d \right]} \quad (25)$$

Where:  $\omega_g$  is the generator speed in (rad/second).

The generator speed ( $\omega_g$ ) equal rotational speed ( $\omega_r$ ) where there is no gearbox between wind turbine and PMSG.

### H. PID Controller design

A typical structure of a PID control system is shown in Figure 7, where it can be seen that in a PID controller, the error signal  $e(t)$  is used to generate the proportional, integral, and derivative actions, with the resulting signals weighted and summed to form the control signal  $u(t)$  applied to the plant model. A mathematical description of PID controller is given by following equation:

$$u(t) = K_p \left[ e(t) + \frac{1}{T_i} \int_0^t e(\tau) d\tau + T_d \frac{de(t)}{dt} \right] \quad (26)$$

Where:  $u(t)$  is the input signal to the plant model, the error signal  $e(t)$  is defined as  $e(t) = r(t) - y(t)$ , and  $r(t)$  is the reference input signal [17].

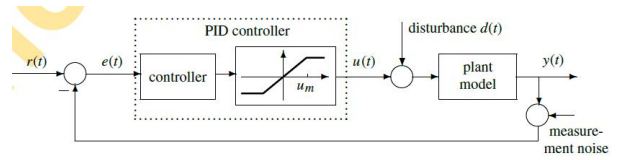

Figure 7: A typical PID control structure.

To adjust the output voltage of boost converter at desired value whatever the load changed, the PID controller is proposed to achieve this task. To design and find controller parameters ( $K_p, K_i$  and  $K_d$ ), the following steps are followed:

A -find the transfers function for the output and the input of the boost-converter by using kerichoff's laws for current and voltage, and apply the Laplace transform

$$V_{in} D T = (V_O - V_{in}) (1 - D) T \quad (26)$$

$$\frac{V_O}{V_{in}} = \frac{1}{1-D} \quad (28)$$

The boost converter operation can be divided into two periods; one of them when the switch is "on", and the other when it is "off":

In the "on" period the inductor current is

$$\frac{di_L}{dt} = \frac{-R}{L} i_L + \frac{1}{L} V_{in} \quad (29)$$

And the capacitor voltage is:

$$V_c = V_O = 0 \quad (30)$$

In the "off" period the inductor current is

$$\frac{di_L}{dt} = \frac{-R}{L} i_L - \frac{1-D}{L} V_c + \frac{1}{L} V_{in} \quad (31)$$

And the capacitor voltage is:

$$\frac{dV_c}{dt} = \frac{1-D}{C} i_L - \frac{1}{RC} V_{in} \quad (32)$$

$$V_c = V_O \quad (33)$$

Where:  $i_L$  is current through the inductor,  $V_c$  is voltage across the capacitor,  $V_{in}$  is DC input voltage and  $V_O$  is DC output voltage [16].

The above equations can be rewritten in state space, during 'on' state as:

$$\dot{x} = A_1 x + B_1 V_{in}; V_O = 0 \quad (34)$$

During "off" state time:

$$\dot{x} = A_2 x + B_2 V_{in}; V_O = q_2 x \quad (35)$$

Where:

$$\dot{x} = \begin{bmatrix} \frac{di_L}{dt} \\ \frac{dV_c}{dt} \end{bmatrix}; A_1 = A_2 = \begin{bmatrix} \frac{-R}{L} & \frac{1-D}{L} \\ \frac{1-D}{C} & -\frac{1}{RC} \end{bmatrix}; B_2 = B_2 = \begin{bmatrix} \frac{1}{L} \\ 0 \end{bmatrix} \quad (36)$$

Then from the Equations (34) and (36)

$$\frac{V_O(s)}{V_{in}(s)} = \frac{M}{1 + s \frac{L}{R} + s^2 LC} \quad (37)$$

$$M = \frac{1}{1-D} \quad (38)$$

$$\frac{V_o(s)}{V_{in}(s)} = \frac{3.33}{1+0.098*10^3S+0.01078*10^3S^2} \quad (39)$$

**Figure 8: the step response of transfer function B** - Apply the Routh rule for stability in order to calculate the gains of PID-controller, depending on Ziegler-Nichols table for PID-controller design

$$K_{Cr} = \frac{\dot{D}}{D} \quad (40)$$

$$T_{Cr} = \frac{0.014}{\dot{D}} \quad (41)$$

where:

$K_{Cr}$  is critical gain .

$T_{Cr}$  is critical time .

Dis "on" time rate for connection .

$\dot{D}$  is "off" time rate for connection.

Table 4: parameters of PID controller.

Controller type	Parameters		
	Kp	Ki	Kd
PID	1.398	0.02333	0.0056

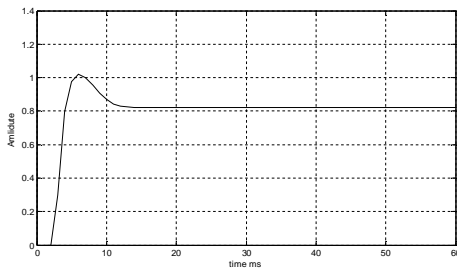

**Figure 9: the step response of transfer function using PID controller**

**I. Fuzzy logic controller**

The Concept of Fuzzy Logic was introduced by Lotfi Zadeh (1965), and its mathematical modeling which is deals with uncertainty. It offers an important concept of soft computing with words. It provides technique which deals with imprecision. The fuzzy theory provides mechanism for representation of linguistic terms such as “many,” “low,” “medium,” “often,” “few.” In general, the fuzzy logic provide an inference structure that enable appropriate human reasoning capabilities. Fuzzy logic systems are suitable for approximate reasoning. Fuzzy logic systems have faster and smoother response than conventional systems and control complexity is less. The fuzzy inference system combines fuzzy IF–THEN rules for mapping from fuzzy sets in the input space X to the output space Y based on fuzzy logic principle. In fuzzy logic, knowledge representation, fuzzy IF–THEN rule is a technique for capturing knowledge that involve imprecision. The main feature of reasoning using fuzzy rules is its partial

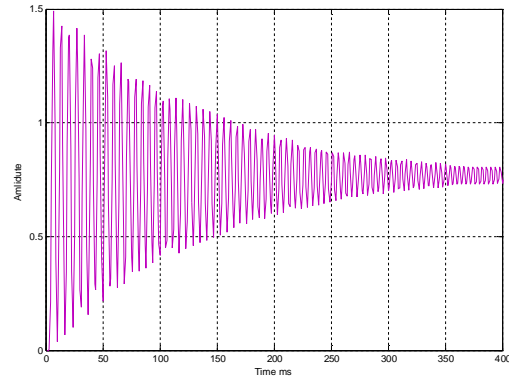

**Figure 8: the step response of transfer function**

matching capability, an inference to be made from fuzzy rule even when the rule’s conditions are partially satisfied. Block diagram of fuzzy logic controller is shown in Figure 10 [18].

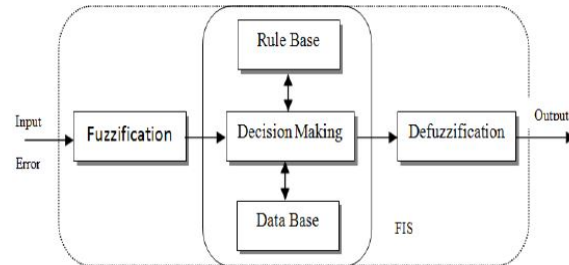

**Figure 10: Block diagram fuzzy control system**

FLC consists of three components namely fuzzification, fuzzy inference system and defuzzification. In general a fuzzy set issued to express a fuzzy variable which is defined by a membership function. The values of membership function vary between 0 and 1. At the heart of the fuzzy rule base are the IF-THEN rules.

**Fuzzification:** it is the process of convert input data into suitable linguistic values. Convert crisp facts into fuzzy sets described by linguistic expressions. Membership functions are triangle shaped, trapezoidal shaped. There are two fuzzification methods which are used mostly, Mamdani and Sugeno. Plots of membership function for input error and output shown in Figure 11 and Figure 12 respectively.



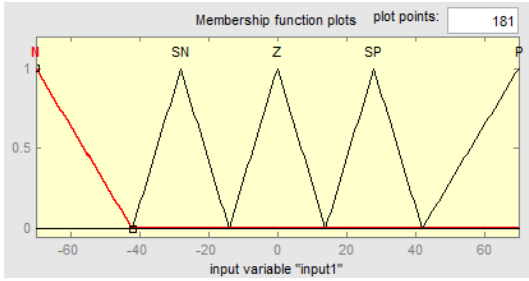

Figure 11: Plot of membership function for input error

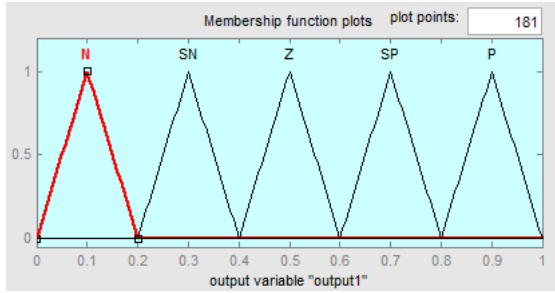

Figure 12: Plot of membership function for output

**Fuzzy Inference System:** The fuzzy IF-THEN rule expresses a fuzzy implication relation between the fuzzy sets of the premise and the fuzzy sets of the conclusion. The rules IF part describes situation for which rules are designed and THEN part describes the response of fuzzy system. For example. IF the Error is N THEN Duty Cycle is Z.

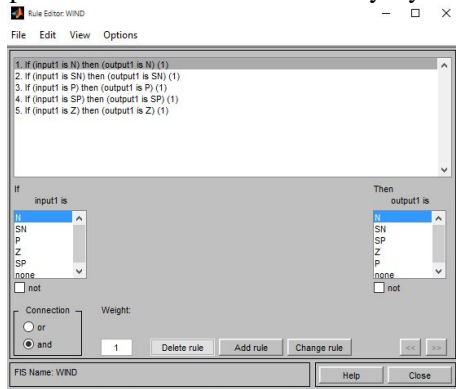

Figure 13: Rules for fuzzy Inference system

**Defuzzification:** To obtain crisp output various defuzzification methods can be used e.g., center of gravity, bisector of area, mean of maximum, Adaptive integration, Fuzzy clustering defuzzification, First of maximum, Last of maximum, Semi-linear Defuzzification, Quality method, Middle of maximum. To obtain a crisp numerical output value [17].

**J. Simulation results**

To study the control of wind turbine system, the system in Figure 14 is built in Simulink

environment. The proposed system is divided into several parts:

- Wind turbine with DD-PMSG.
- Converters (AC/DC-diode rectifier, DC/DC-Boost converter, DC/AC- Inverter).
- Filter to eliminate the harmonic from voltage and current wave.
- Load.
- Control of duty cycle that is generated from PWM Generator which takes output signal from (Fuzzy or fuzzy- PID controller as MPPT controller) to represent input signal to the IGBT/diode.
- **Operational without control**

The simulation of the system in Figure 14 is first run without control. Figure 15 shows the DC voltage at the terminal of Boost- converter without input signal to IGBT/diode. We note, there is variable DC voltage with large variation (400-900) which is given also variable AC voltage at the terminal of the load/grid with the same variation as in Figure 15 and Figure 16.

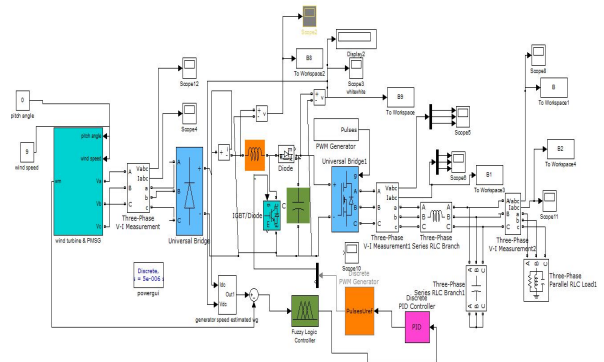

Figure 14: shows all components of proposed system

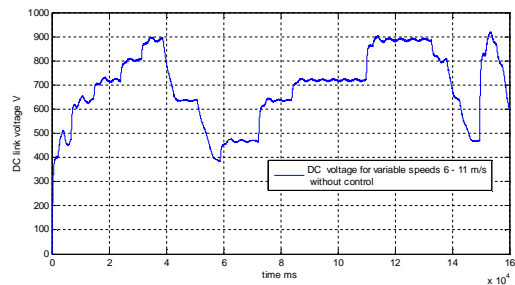
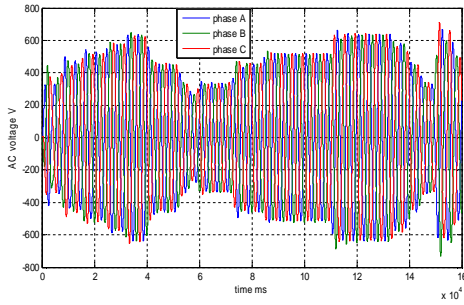

Figure 15: DC Link voltage at terminal boost-converter for variable wind speeds





**Figure 16: AC Voltage after filter for variable wind speeds (6 – 11 m/s)**

Table 5: shows the parameters of PMSG and filter are applied in MATLAB/SIMULINK

The investigation of the control scheme of the wind turbine system of variable speed is carried

Component Type	Parameter	Value
Direct Drive PMSG Parameters	Stator phase resistance Rs	0.00175 6 ohm
	Inductance Ld	0.1985 mH
	Inductance Lq	0.1985 mH
	Voltage Constant (V_peak L-L / krpm)	5kV
	Rated power	0.5 MW
	Inertia J	0.008 $\frac{kg}{m^2}$

**II Operational with control**

The system in Figure 14 is operated in operation condition with control using fuzzy logic controller and fuzzy-PID controller connected with PWM generator to generate pulse with variable " on " - "off " period of duty cycle and constant frequency to be input signal for transistor " IGBT/diode ", this part of control represent as MPPT controller to give constant DC voltage at the terminal of Boost-converter as input DC voltage for inverter this voltage must be unaffected by changing in wind speeds. Figure 17 shows AC voltage generated from PMSG for rated speed 9 m/s similarly AC current is shown in figure 18. Figure 19 shows the wave form of unregulated voltage after rectification.

figure 20 shows DC voltage at terminal of boost-converter for different wind speeds at constant value using only fuzzy logic controller but for the variable wind speeds is appeared in figure 21

out using MATLAB/Simulink environment. The system in Figure 14 is modeled and simulated in the MATLAB software with the parameters given in table 5.

The operational conditions for controlling the proposed WECS include: (i) operation without controller, (ii) operation with controller.

**I Operational without control**

The simulation of the system in Figure 14 is first run without control. Figure 15 shows the DC voltage at the terminal of Boost- converter without input signal to IGBT/diode. We note, there is variable DC voltage with large variation (400-900) which is given also variable AC voltage at the terminal of the load/grid with the same variation as in Figure 15 and Figure 16.

	friction factor	0.0001 N.m.s
	pole pairs	128
Filter	The inductor	54mH.
	The capacitor	14.5 $\mu F$ .
Load parameters	Nominal phase-to-phase voltage	415 V
	Nominal frequency	50 Hz
	Active power P	600 W
DC link parameters	DC link voltage	620 V
	The inductor of boost-converter	98mH
	The capacitor of boost-converter	0.11mF

which shows also DC voltage with small variation (600-700V) which is undesirable for specified value (620 V).

Figure 22 shows DC voltage at terminal of boost-converter for different wind speeds using fuzzy-PID controller, figure 23 shows constant DC voltage with very small variation (600-630V) for constant value 620 V, this variation is considered acceptable compared to fuzzy logic controller. Similarly this constant DC voltage gives constant AC voltage 415V with constant frequency 50Hz according to setting of PWM generator for inverter as in figure 25 which shows constant AC voltage after filter at the load terminal. Figure 24 shows Wave form of voltage before filter and Figure 26 presents Pulse that is generated from PWM generator.

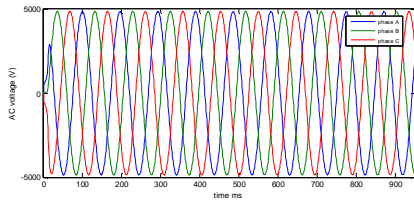

Figure 17: AC Voltage from PMSG for rated speed 9 m/s

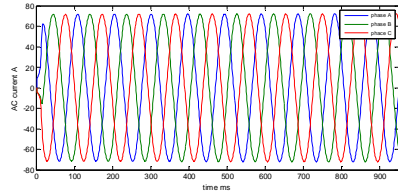

Figure 18: AC Current from PMSG for rated speed 9 m/s

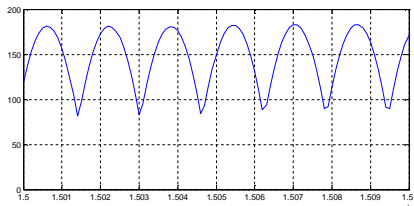

Figure 19: Wave form of unregulated voltage after rectification

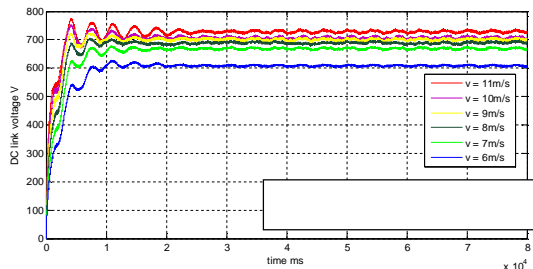

Figure 20: DC Voltage at terminal of boost-converter for different wind speeds using (FLC)

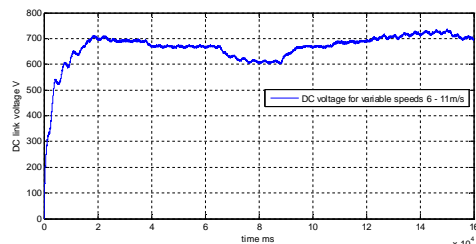

Figure 21: DC Voltage at terminal of boost-converter for variable wind speeds using (FLC)

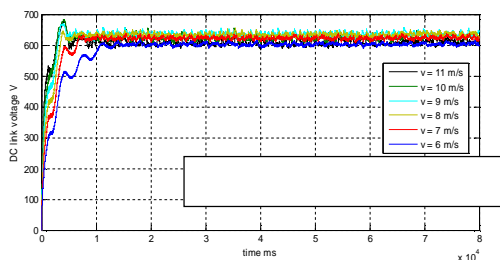

Figure 22: DC Voltage at terminal of boost-converter for different wind speeds using fuzzy-PID controller

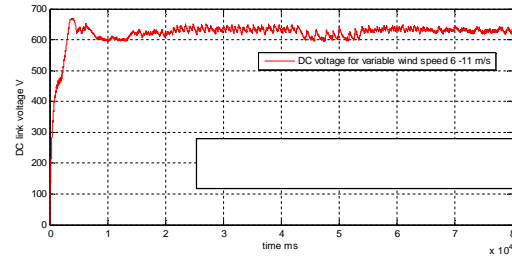

Figure 23: DC Voltage at terminal boost-converter for variable wind speeds

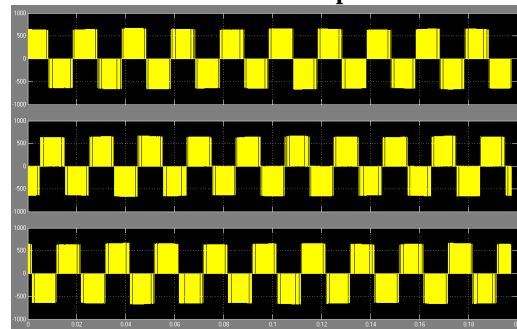

Figure 24: Wave form of voltage before filter

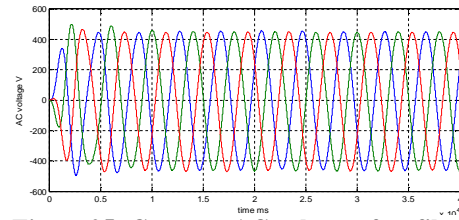

Figure 25: Constant AC voltage after filter

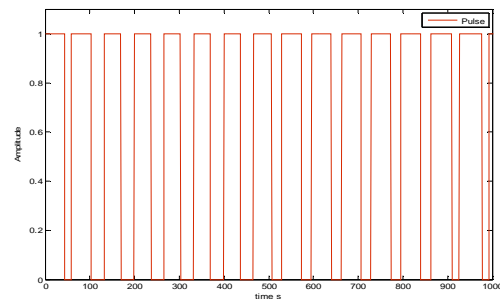

Figure 26 : Pulse generated from PWM generator

### CONCLUSION

The maximum power point can be tracked from the wind using fuzzy-PID as MPPT controller to control of duty cycle that is presented. The maximum power is tracked based on rotor speed of the wind generation system that represents in error between actual rotor speed of generator and estimated value of rotor speed depend on value of DC current and voltage at the terminal of boost-converter and parameters of PMSG. The performance of fuzzy-PID controller is best compared to fuzzy logic only. Possibility of obtaining AC voltage with constant amplitude and frequency at the load terminal for the changing in the wind speeds.

### REFERENCES

- [1] UNDP. Project Document. (2014). Promoting Utility Scale Power Generation from Wind Energy. Pages: 10 - 11
- [2] Lesic, M. Vasak, and Joksimovic (2011). Fault to lean control of a blade pitch wind turbine with inverter fed generator", IEEE Conf., International Symposium on Industrial Electronics (ISIE), Vol. 1, No. 1, PP. 2097-2102
- [3] J.F. Manwell, and A.L. Rogers, [2002]. Wind Energy Explained - Theory, Design and Application. Pages: 2-15
- [4] Erich hua (2005). Wind turbines—fundamentals, technologies, application and economics. 2nd edition. Pages: 68-78
- [5] Tony Burton and David Sharpe. (2001) wind energy - handbook. Pages: 42-46
- [6] Akash Alex Paret. (2014). PID Controlled Frequency Regulation Of Wind Turbine. International Journal of Advanced Research in Electrical, Electronics and Instrumentation Engineering Vol. 3, No 3. Pages: 2-5
- [7] Vishal T. Makvana and Jitendra A. Jadhav (2013). Study of PID Controller Based Pitch Actuator System for Variable Speed HAWT using MATLAB. International Journal of Innovative Research in Science, Engineering and Technology Vol. 2, No 5. Pages: 1-5
- [8] Saravanakumar Rajendran (2014). Control of Variable Speed Variable Pitch Wind Turbine at Above and Below Rated Wind Speed. Hindawi Publishing Corporation Journal of Wind Energy Volume. Pages: 1-3
- [9] Rupendra and Yogesh (2014). Mechanical Control Methods in Wind Turbine Operations for Power Generation. Journal of Automation and Control Engineering Vol. 2, No. 3: pages: 2-7
- [10] Sachin Khajuria and Jaspreet (2012). Implementation of Pitch Control Of wind Turbine Using Simulink (Matlab). International Journal of Advanced Research in Computer Engineering & Technology Volume 1, Issue 4. Pages: 2-5
- [11] Luis Alberto and Hugo (2012). Fuzzy Proportional Integral Control for a 1.5 MW Wind Turbine. Revista Universitaria, Telecomunicaciones Informática Control. ISSN 2227 – 3735. Pages: 5-6
- [12] Umesh Kumar Soni (2015). Pitch Control of CFVWS Turbine Using PID Controlled Internal Pitch Loop. International Journal of Electrical, Electronics and Computer Systems (IJEECS) , Volume -3, Issue-3. Pages: 3-6
- [13] Hamed Habibi and Aghil Yousefi-Koma (2014). Wind Turbine Integrated Control during Full Load Operation. The 10th international Energy Conference (IEC).
- [14] Gary L. Johnson. (2001) Wind Energy Systems. Electronic Edition. Pages: 97-110
- [15] Rogres, Everett. (2002) Understanding Buck Boost Stages in Switch Mode Power Supplies.
- [16] Dingyü Xue. Yang Quan Chen. Derek P. Atherton (2007). Linear Feedback Control Analysis and Design with MATLAB. Electronic Edition.
- [17] Mahmoud M. Hussein and Mohamed Orabi, Hamada (2013). Control of a Stand-Alone Variable Speed Wind Energy Supply System. journal of applied sciences. Pages: 440-443
- [18] Amin Alqudah, Ahmad Malkawi, Abdullah Alwadi. (2014). Adaptive Control of DC-DC Converter Using Simulated Annealing Optimization Method. Journal of Signal and Information Processing. Pages: 199-205
- [19] Chetan and Dhumale (2015). DC-DC Converter Using Fuzzy Logic Controller. International Research Journal of Engineering and Technology (IRJET). Volume: 02 Issue: 04. Pages: 594-595
- [20] Tian Pau Chang (2010). Wind Speed and Power Density Analyses Based on Mixture Weibull and Maximum Entropy Distribution. International Journal of Applied Science and Engineering. Pages: 40-44
- [21] Abdeen Mustafa Omer (2006). The wind energy resources of Sudan. Journal of Renewable and Sustainable Energy Reviews.
- [22] Eugene C. Morgan and Richard (2011). Probability distributions for offshore wind speeds. Journal of Energy Conversion and Management.
- [23] Sophie and Peter Knippertz (2015). The importance of rare, high-wind events for dust uplift in northern Africa. Geophysical Research Letters.
- [24] Yusuf Yakhor and Zena Ali. (2014). Design and Modulation of Wind Energy Conversion System in Kouttina to be Coupled with Syrian Electrical Grid. Tishreen University Journal for Research and Scientific Studies - Engineering Sciences Series Vol. (36) No. (2).

