



بِسْمِ اللَّهِ الرَّحْمَنِ الرَّحِيمِ



SUDAN UNIVERSITY OF SCIENCE AND TECHNOLOGY

COLLEGE OF GRADUTE STUDIES

**Impact of number of Hops and Paths on Wireless Sensor
Network Performance**

تأثير عدد الفقرات والمسارات على أداء شبكة أجهزة الاستشعار اللاسلكية

**A thesis submitted In partial fulfilment of the Requirements for the Degree of
Master of Computer Engineering and Networking**

AKEL KASIM LEABY

SUPERVISOR: Dr. AHMAD ABDALAH

2017

بِسْمِ اللَّهِ الرَّحْمَنِ الرَّحِيمِ

هُوَ الَّذِي جَعَلَ الشَّمْسَ ضِيَاءً وَالْقَمَرَ نُورًا وَقَدَّرَهُ
مَنَازِلَ لِتَعْلَمُوا عَدَدَ السِّنِينَ وَالْحِسَابَ ۗ مَا خَلَقَ اللَّهُ
ذَلِكَ إِلَّا بِالْحَقِّ ۗ يُفَصِّلُ الْآيَاتِ لِقَوْمٍ يَعْلَمُونَ
(الاية 5 ، سورة يونس)

صدق الله العظيم

DEDICATION

To my (Father, Mother and my Wife)

To my children's (Mohammed, Aya , Minat Allah)

For their Patience and bearing

To my all friends who help me.

I dedicate this work

ACKNOWLEDGEMENTS

First of all, I am grateful to **ALLAH** the Almighty for all blessings in this life and for giving me power and ability that were necessary to achieve this goal. All thanks and praises are due to **ALLAH** “**Al-hamdulillah**”.

I would like to express my sincere gratitude to my supervisor **Dr. Ahmad Abdalah** for the continuous support of my M.Sc. study and research, for his patience, motivation, enthusiasm.

My sincere thanks also goes to **my friends** who help me to complete this study .

Last but not the least, I would like to thank my family:

my great Father , To the brilliant Mother and my Wife who stood up to me with help,
To my Children’s.

To all those whom I have mentioned, and those who have not sought memory, I have forgotten their virtue, I will tell them (**THANK YOU**).

ABSTRACT

In the last decade, there was rapid growing of Wireless Sensor Networks (WSNs) for research and commercial uses. Low-cost/low-power WSNs techniques are utilised in various applications such as smart-home, industrial control, health care, agricultural fields, environmental purposes, biomedical systems, and scientific applications. The aim of this research is to find the suitable number of paths and hops in each path to be used in transmit power control protocols for multi-path uniform density single-channel WSNs. This work aims to achieve two goals: (1) to reduce energy depletion and prolong the battery lifetime of sensor nodes by using transmit power control and, (2) to keep throughput and packet loss neutral by using multi-path routing. A limitation of most previous studies that aim to minimise transmit power is that they fail to take into consideration the throughput reduction. Through a number of case studies, it was determined that trying to reduce the power by using multi-hopping also results in the reduction of end-to-end throughput. Microsoft excel was used to calculate the mathematical equations results and draw graphs for the relations needed to be obtained. Given our assumptions, the result show that the optimal number of hops must be between two and six hops to save energy. This is mainly due to the overhead of each packet as the receive power of the sensor nodes. It was also determined that there is no need to have more than two paths between source and destination in order to achieve throughout neutrality.

المستخلص

في العقد الماضي، كان هناك نمو سريع في شبكات الاستشعار اللاسلكية لأغراض البحث والاستخدامات التجارية. وتستخدم تقنيات شبكات الاستشعار اللاسلكية لأنها منخفضة التكلفة ، منخفضة الطاقة في مختلف التطبيقات مثل المنزل الذكي، والسيطرة الصناعية، والرعاية الصحية، والحقول الزراعية، والأغراض البيئية، والنظم الطبية الحيوية، والتطبيقات العلمية. والهدف من هذه الأطروحة هو العثور على العدد المناسب من المسارات والعدد المناسب للمحطات (مستشعرات لاسلكية) في كل مسير لاستخدامه في بروتوكولات التحكم في القدرة على الإرسال لكثافة موحدة تعمل على بروتوكولات التمير عبر طرق متعددة في شبكات الاستشعار اللاسلكية. ويهدف هذا العمل إلى تحقيق هدفين: (1) الحد من استنزاف الطاقة وإطالة عمر البطارية من العقد الاستشعار باستخدام التحكم في الإرسال ، (2) للحفاظ على الإنتاجية باستخدام التوجيه متعدد المسارات. ان معظم الدراسات السابقة تقلل من صرف الطاقة عند الارسال من خلال زيادة عدد المحطات الوسطية وبالتالي تقليل مسافة الارسال ولكن المشكلة تكمن في أنها لا تأخذ في الاعتبار خفض الإنتاجية. من خلال دراسة عدد من الحالات للوصول الى معادلات تستخدم لحساب الطاقة المصروفة في الارسال وكذلك لقياس الانتاجية في الشبكة تم تحديد أن محاولة تقليل الطاقة باستخدام التنقل المتعدد المراحل يؤدي إلى الحد من الإنتاجية من طرف إلى طرف. نظرا لافتراضاتنا المقترحة. تم استخدام برنامج مايكروسوفت إكسل لحساب المعادلات الرياضية ورسم الرسوم البيانية والجداول للعلاقات التي نحتاج للحصول عليها. وأظهرت نتائج تطبيق المعادلات أن استخدام سيناريوهات القفزات اثنين وثلاثة وأربعة وخمسة وستة يمكن أن يعزز بشكل ملحوظ كفاءة استخدام الطاقة، ويجب أن يكون العدد الأمثل للمسارات غير المتداخلة مسارين لتعزيز حيادية الإنتاجية في الشبكة.

Contents

آية من القرآن الكريم	ii
Dedication	iii
Acknowledgements	iv
Abstract.....	v
المستخلص.....	vi
List of tables	x
List of figures.....	xi
List of Abbreviations	xiii
Chapter one	1
Introduction.....	1
1.1 Background	1
1.2 Problem statement.....	2
1.3 Objectives:	2
1.4 Methodology	2
1.3 Thesis layout	3
Chapter two	4
Literature Review	4
2.1 Introduction.....	4
2.2 Wireless Sensor Network.....	4
2.3 Energy-efficient in wireless sensor networks	5
2.3.1 Path loss factor (α)	5

2.3.2 Distance ratio (d).....	6
2.4 TPC Protocols	7
2.5 TPC in WSNs.....	9
TPC in IEEE 802.11 WSNs	9
TPC protocols in IEEE 802.15.4 WSNs	10
TPC for MANETs.....	11
2.6 Routing protocol in WSNs.....	14
2.7 WSNs Multipath routing protocols classification.....	16
2.7.1 Multipath routing protocols for energy efficiency.....	17
2.7.2 Multi-path routing protocols for fault tolerance	19
2.7.3 Multi-path routing protocols for reliability.....	20
CHAPTER three	24
METHODOLOGY	24
3.1 Introduction.....	24
3.2 Overall methodology	24
3.2.1 Network model assumptions:.....	24
3.2.2 Case study summery	26
3.3 study of scenarios.....	28
3.3.2 Maintaining Throughput in wireless sensor networks	35
3.4 Conclusions.....	40
Chapter four	41

results and discussion	41
4.1 Introduction.....	41
4.2 Power consumption graphs	41
4.3 throughput graphs	43
Chapter five	47
Conclusions And recommendation.....	47
5.1 Conclusions.....	47
5.2 Recommendations	47
Reference	48

LIST OF TABLES

Table (2.1) summery of TPC protocols previous studies.....	13
Table (2.2) summery of multi-path routing protocols for WSNs.....	23
Table (3.1) summery of power consumption scenarios and throughput equations	27
Table (4.1) results of equation (3.4).....	42
Table (4.2) throughput of multi-path with variable number of hops.....	45
Table 4.3 number of hops with power consumption and network topology	46

LIST OF FIGURES

Figure (2.1) sensor node stages.....	4
Figure (2.2) Distance ratio for single path topology.....	6
Figure (2.3) Distance ratio for two hops topology.....	7
Figure (2.4) Distance ratio for three hops topology.....	7
Figure (2.5) Transmission range of WSNs.	8
Figure (2.6) using different transmitting power level for different nodes.	8
Figure (2.7) TPC protocols Classification.	9
Figure (2.8) Classification of the multi-path routing protocols for WSNs.....	17
Figure (2.9) Schematic diagram of BMR protocol.....	20
Figure (2.10) ECMP mechanism	21
Figure (3.1) (steps of methodology)	25
Figure (3.2) Single path/single hop topology	28
Figure (3.3) Multi-hop/multi-path topology.	29
Figure (3.4) Single hop/single path topology study.....	30
Figure (3.5) Two hops with single and multi-paths topologies.	31
Figure (3.6) Two hops with single and two paths topologies.	32
Figure (3.7) Three hops with single path and two paths topologies.	33
Figure (3.8) (Single hop/single path) and (2 hops/ multi-paths) topologies.....	36
Figure (3.9) Three-hops in single path and multiple paths topology.....	38

Figure (3.10) Four-hops in single and multiple paths topologies	39
Figure 4.1 total power consumption for each packet with ($\alpha=2$)	42
Figure (4.2) throughput of multipath / multi-hop	45
Figure 4.3 power consumption with throughput with different hop number.....	46

LIST OF ABBREVIATIONS

ACK	Acknowledgment
Aco	Ant Colony Optimisation
AODV	<i>Ad hoc</i> On-demand Distance Vector Routing
BER	Bit Error Rate
B-MAC	Berkely-MAC
BS	Base Station
CBR	Constant Bit Rate
CCA	Clear Channel Assessments
CH	Cluster Heads
CSMA	Carrier Sense Multiple Access
CSMA/CA	CSMA with Collision Avoidance
CSMA/CD	CSMA with Collision Detection
CTS	Clear To Send
DSR	Dynamic Source Routing
E-MAC	Eyes MAC
ETX-metric	Expected Transmission Count Metric
GPS	Global Positioning System
GW	Gateway

Hop-count	Hop Count Metric
IEEE	Institute of Electrical and Electronics Engineers
LAN	Local Area Network
LEACH	Low Energy Adaptive Clustering Hierarchy
L-MAC	Lightweight MAC
LQI	Link Quality Indicator
MAC	Medium Access Control
MANET	Mobile Ad-hoc wireless Network
Multi-path	Multiple path
PER	Packet Error Rate
PHY layer	Physical layer
QoS	Quality of Service
ERR	Route-error
RREP	Route-reply
RREQ	Route-request
RSSI	Received Signal Strength Indicator
RTS	Request To Send
SINR	Signal to Interference and Noise Ratio
SIR	Signal to Interference Ratio
SlotCA	Slotted Channel Access

S-MAC	Sensor-MAC
SNR	Signal to Noise Ratio
TC	Topology Control
TDMA	Time Division Multiple Access
TPC	Transmit Power Control
Txpower	Transmission Power
TxRange	Transmission Range
WiFi	Wireless Fidelity
WSN	Wireless Sensor Network

CHAPTER ONE

INTRODUCTION

1.1 Background

Wireless sensor networks (WSNs) consist of small nodes with sensing, computation, and wireless communications capabilities (Al-Karaki and Kamal, 2004). WSNs consist of a large number of sensor nodes, composed of processor, memory, battery, sensor devices and transceiver. These nodes send monitoring data to an access point (AP), which is responsible for forwarding data to the users (Correia et al., 2005). Communication is usually the most energy-consuming event in Wireless Sensor Networks (WSNs). One way to significantly reduce energy consumption is applying transmission power control (TPC) techniques that dynamically adjust the transmission power (Correia et al., 2007).

Due to the battery resource constraint, it is a critical issue to save energy in wireless sensor networks (Chen et al., 2005). Recent advance in micro-electromechanical system technology has made it possible to develop low-power and low-cost sensors with at a much reduced cost, so that large wireless sensor networks with thousands of tiny sensors are well within the realm of reality. These large sensor networks are able to support many new applications, including habitat monitoring (Chen et al., 2005)

One of the major challenges in WSNs is to reduce energy consumption while maintaining throughput. It is logical to use Transmit Power Control (TPC) to reduce power consumption by using multi-hopping, but this result in throughput reduction. Throughput neutrality can be obtained if the flow-out data rate from a region is equal to the region flow-in data rate such that there must be enough paths to eliminate the throughput reduction due to multi-hopping. Using two or more non-interfered paths may offer possible solution to maintain overall network throughput as well as reduce end-to-end delay.

1.2 Problem statement

In WSNs transmission of data over multi-hops path saves energy. However, transmission of data over multi-hops path affects network throughput due to multiple send and receive operations done by each node. The suitable number of nodes and number of parallel paths need to be found to build network model to reduce power consumption by saving battery life time and network throughput naturalize at the same time.

1.3 Objectives:

Reducing the power consumption in wireless sensor network by finding the optimal number of paths and number of hops in each path that minimize the power consumption and naturalize the throughput to:

- Prolong the battery lifetime of sensor nodes.
- Reduce interference between sensor nodes. This results in increased network lifetime and throughput.

1.4 Methodology

This research will search for the suitable WSNs topology that minimize the power consumption and has the less effect on WSN throughput. The method followed in this research uses a graph-theory approach. This is one of the more practical ways to abstract the network topology. Besides, will use Microsoft excel to apply the equations found in chapter three and plot graphs and write tables of data resulted.

The aims and objectives of thesis will be targeted by addressing the following key research tasks:

- Determining the number of hops required to save energy and the number of paths needed to maintain the overall network throughput.
- Examining the effects of the number of hops on the throughput and energy consumption of a single-channel/single-transceiver WSN.

1.3 Thesis layout

The overall structure of the study takes the form of five chapters, including this introductory chapter. As it has already been shown,

Chapter 2 includes three important sections. The first section presents a literature review on dense WSNs. The second section provides a detailed and extensive study about TPC protocols. In this section, an extensive table is provided that lists relevant TPC protocols and their potential shortcomings in maintaining throughput. The third section outlines the current multi-path routing protocols, as well as the advantages and disadvantages of the multi-path routing protocols, with and without TPC.

Chapter 3 begins by laying out the theoretical dimensions of the research, and then looks at the main findings to specify the contribution of the current study and find the optimal topology for the proposed algorithm.

Chapter 4 provides graphs for the equations that obtained in network model assumed in chapter three and with its conditions and finally the result show which is the suitable topology that reduce power consumption and maintain throughput.

Chapter 5, contains the conclusion and future work recommendations.

CHAPTER TWO

LITERATURE REVIEW

2.1 Introduction

This chapter will describe the previous knowledge in both transmit power control (TPC) and multipath routing protocols for wireless sensor network (WSNs). This chapter will describing an overview on WSNs, and then it will explain the related work to find the optimal method that used for transmission power control in WSNs.it Next, will take the use of multipath routing protocols in wireless sensor networks.

2.2 Wireless Sensor Network

Wireless sensor networks (WSNs) composed from small sensing devices, it rapidly developed and used in many of life fields. The sensor node constructed from power unit which is battery, processing unit represented by microprocessor, memory, and a channel for transmit and receive for short range transmitting (Sagduyu and Ephremides, 2004),(Cerpa and Estrin, 2004) . Fig 2.1 shows the diagram of sensor node stages.

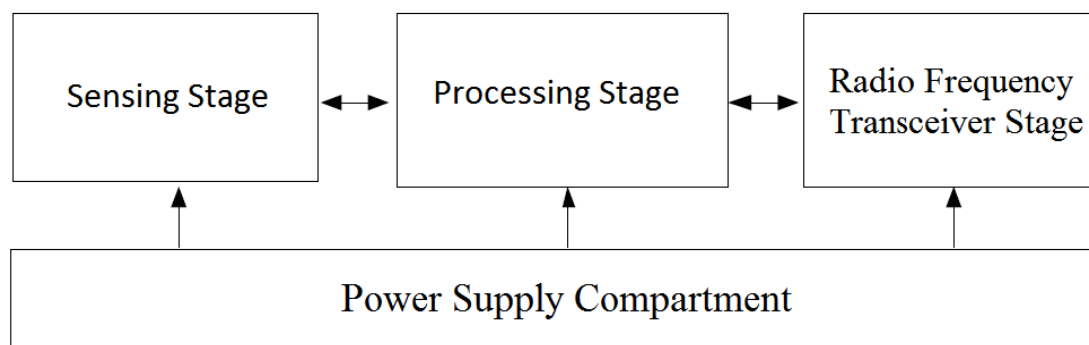

Figure (2.1) sensor node stages

As shown in Fig 2.1, the brain and controller of all nodes stages is the processing stage which contain processor and related memory. The job of sensing stage which connected to processing stage is to sensing the environment outside node and then converting the analogue signals which collected from outside environment to digital signals. The communication between nodes through wireless medium is the responsibility of radio

frequency transceiver stage (Al-Karaki et al., 2004). Each of radio frequency and processing units stages are required power consumption, each stage may need a different levels of input power which is the responsibility of power supply compartment(Al-Karaki et al., 2004), 9 (Akkaya and Younis, 2005).The limited power in power supply is the most effected problem because it is mostly cannot be replaced in far distributed networks (Shin et al., 2006). The processing stage and exchanging unit are the most power consumption effect operations in sensor nodes, it consume a considered amount.

The most effected problem faces the development of WSNs is the battery replacement problem, as an example sensor nodes deployed in far and dangerous environment such as desert or A forest of trees in a very distant place (Subramanian and Buddhikot, 2006).

Sensor node stages must work with protocols that optimized the power loss and help to eliminate the expected problem of power consumption and without effecting on other side such as throughput , network reliability , interference and data loss rate , which are the expected problem faces the development of WSNs (Meghji and Habibi, 2011a),(Meghji et al., 2012). Research studies were focus on extending the network lifetime and saving energy. In real WSNs the no. of nodes is vary from one to thousands of nodes, these nodes are distributed in a wide area, these nodes are communicate with each other frequently. The network topology may change when there is a node failure or node operation weak. So these WSNs need to be managed by suitable routing protocols (Adya et al., 2004)

2.3 Energy-efficient in wireless sensor networks

If the node has IEEE802.11 single channel/single transceiver and the node has adjustable transmission power level. So, each node can utilize the lowest transmitting power in order to deliver data packets into the neighbour nodes and utilize multi-hoping technique until reach the destination. Minimizing transmission range will reduce the individual energy consumption as well as total average of energy depletion.

2.3.1 Path loss factor (α)

When transmission operation is achieved by sensor node; the electromagnetic waves can be formed as a sphere spreading out away from a source point. The energy of this wave front dissipates with the square of the area, which called (path loss). Path loss rate is called

(path loss exponent) (α). path loss is true for each frequencies ranges. Path loss factor takes range value between 2 to 4; it takes value of 2 in free space propagation and can takes value of 4 in high frequency range. Path loss can be caused by atmospheric conditions, bad weather and front spreading out. In this research will assume the network work with free space propagation (path loss factor =2).(Guoqiang et. al.,2007).

2.3.2 Distance ratio (d)

Additionally, we need to formulate an equation to compute both total power consumption (P_T) and relative power consumption for each node (P_n) in terms of normalized transmission ($P_{tx}(n)$), which defined as (relative *transmit* power consumption). And for no. of nodes (N), ($P_{rx}(n)$) is the relative *receive* power consumption at receiving mode.

For no. of nodes (N), no. of hops (h), we can formulate an equation to find the value of distance ratio (d) which is the value of node space divided over the total transmission range.(Ruifeng z. et. al. ,2008).



Figure (2.2) Distance ratio for single path topology.

as shown in Fig 2.2, refers to source as S and destination as D to formulate an equation for distance ratio, we assume that the nodes must divide the transmission range equally as condition to be the general equation.

In Fig 2.3, there are no intermediate node and the transmitting power is maximum and so that the transmission range is the maximum too, thus,

$$(d = 120/120 = 1).$$

In Fig 3.4 there is one intermediate node in the path, so it divides the path to two halves, can say ($d = 60/120 = 0.5$).



Figure (2.3) Distance ratio for two hops topology.

Fig 2.4, there are two intermediate nodes in the path divide the path to one third of path, so, ($d=40/120=0.3333$).



Figure (2.4) Distance ratio for three hops topology.

If the transmission range split equally between nodes and the no. of hops is (h), so the value of distance ratio (d) can be calculated according to the value:

$$d=1/h \quad \text{equation 2.1}$$

2.4 TPC Protocols

As a solution for power consumption when transmitter send data to the receiver, TPC protocol was invented, it can assumed as a conversation between nodes to reach the transmission power level that achieve the goal of minimum power consumption. TPC also is a method to prevent the receiver to be overwhelmed by transmitter. Many of researches were interested in power consumption in multi-hop WSNs , TPC is extending the network lifetime, this completed by applying the TPC protocol to set the minimum possible transmitting level of power to deliver data from source to the destination. Previous studies proposed that TPC is expected to manage power spending in dense WSNs (Zhao and Guibas, 2004),(Monks et al., 2001). In order to extend WSN life time, it is required to minimize the power level with maintaining the throughput and loss neutral. Fig 2.2 shows TPC in IEEE 802.11 network.

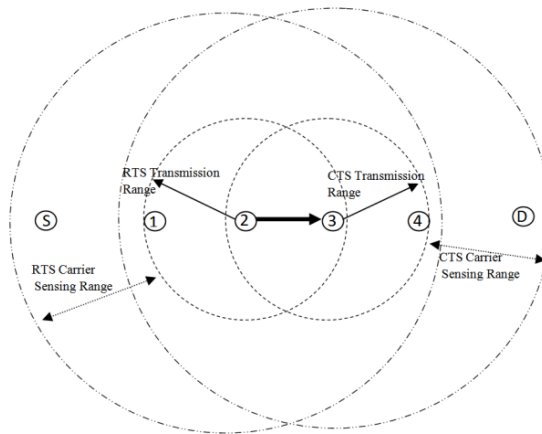

Figure (2.5) Transmission range of WSNs.

In the Fig 2.5, the control message is send with maximum power, so it suffer from collision because of this, after sending control messages between source and destination nodes, when Node 2 is the transmitter and node 3 is the receiver, the node D cannot sense the transmission of the data between node 2 and node 3 because Node D is in the sensing range of Node 3 but not in that of Node 2. Therefore, when Node D wants to send data, a data collision can occur if Node 3 is a destination. This problem defined as hidden node problem. We can keep away from this type of problems and also minimize the power consumption level by using TPC protocol as shown below in Fig 2.6

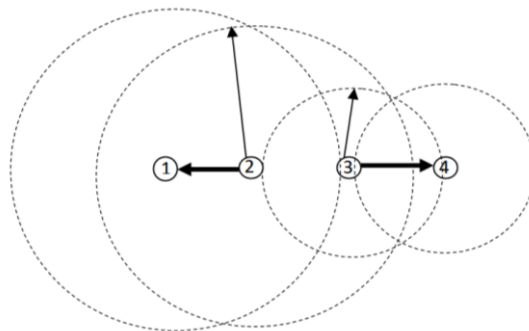

Figure (2.6) using different transmitting power level for different nodes.

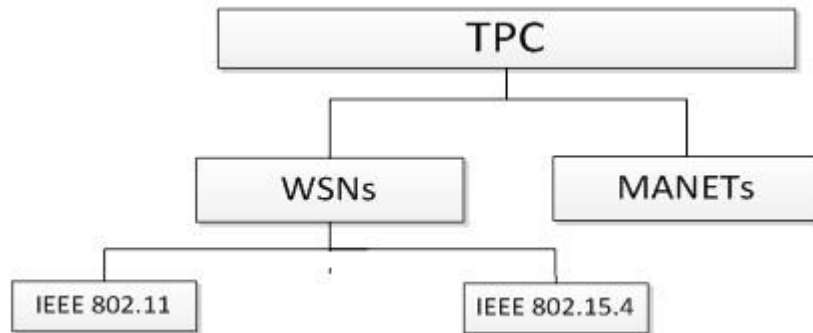

Figure (2.7) TPC protocols Classification.

2.5 TPC in WSNs

As in figure 2.7 which show the classification of TPC note that it can be mainly utilised in IEEE 802.11 and IEEE 802.15.4.

TPC in IEEE 802.11 WSNs

In standard wireless networks IEEE 802.11 , we note wide use of TPC protocols (Fitzek et al., 2003), (Adya et al., 2004). There are many studies deals with single path /single channel case in IEEE 802.11 MAC , which results show that . A number of studies have revealed that single-channel/single-transceiver IEEE 802.11 MAC protocols fail to perform effectively in these environments with regard to energy efficiency and throughput neutrality. Current research findings have prompted future research to focus on TPC protocols that are suitable for WSNs operating in multi-hop topologies without throughput reduction (Fitzek et al., 2003).

By proposing an algorithm for TPC protocol based on adjusting transmission energy level depending on link margin , received signal strength and data loss rate. (Viswanathan, 2009) developed an adaptive (link-per link) TPC algorithm that used based on multi-hop IEEE 802.11n networks. This algorithm also solve the hidden nodes problem by modifying

the power consumption for transmission, the research goal is to decrease the interference level between pairs of sender/receiver, and increase network performance . This study success to avoid interference. However, network throughput was developed by 60%. Choi (Choi and Lee, 2014) proposed distributed TPC protocol to address wireless multi-hop network problem for distributed networks. The transmission power is selected based on link-quality at each hop, the study goal is to maximize throughput. The proposed protocol was developed to select the transmission power individually. They success to improve the throughput gain in multi-hop networks and decrease the transmission power in all active nodes .

TPC protocols in IEEE 802.15.4 WSNs

(Lee and Choi, 2006) utilized a new technique to reduce energy depletion and maintain throughput. They suggested an adaptive transmission power control protocol (ATPC) to reducing the number of control message overheads by employing both (open-loop) and (closed-loop) feedback systems. In ATPC, all nodes in open loop feedback system estimate the link quality by utilizing a suitable TPC protocol, the degradation of link quality would be reimburse by all nodes . Additionally, control messages will be employed to obtain a recommend TPC protocol. This will done by closed-loop feedback system.

The suitable TPC protocol mentioned above measures the received signal strength indication (RSSI) by transmission interface. The results show that periodically change in link quality depends on alternating of received signal strength. So, the adaptive TPC protocol can be applied for small-scale WSNs and it is not appropriate for large-scale WSNs.

(Kamarudin et al., 2010), proposed a protocol with realistic radio energy algorithm, in order to send data into the base station (BS) with optimal power level, this level selected automatically depending on both measured path loss factor and estimated received power level. In this study, they can extend the network lifetime when use free space model and estimate the path loss factor. Also , advance about (8.7%) has been achieved in side of energy efficiency. If the sensor nodes are arranged in an agriculture field. This study has limitation which is single environment case study and pre-existing features in WSNs including end-to-end throughput were not considered.

(Das and Chaki, 2011), proposed a "novel quarry driven routing", in this algorithm use the balance technique of TPC protocol. For WSNs "novel quarry theory routing" algorithm adjusts the per-node transmission power level depending on next-hop adjacent node with maximum remaining energy. In this study, node lifetime extending can be achieved and energy depletion of IEEE 15.4 can be minimized. But the throughput effected by using multi-hop topology.

(Messier et al., 2008) , developed TPC algorithm , it depend on cross layer optimization theory in the physical layer for IEEE 15.4 WSNs which define as a cross –layer power control (CLPC). The results of this study show that they can achieve the best network performance. Also, power saving goal can be reached with the developed CLPC algorithm compared with original CLPC algorithm. The weakness of this results that there is no more comparisons with other common existing MAC protocols.

TPC for MANETs

In this section, we will take two previous studies that was tried to optimize the transmission power in MANETs, which refer to groups of wireless nodes arranged in mobile ad-hoc groups. These nodes have the ability of route packets among them (Abduljaleel et al., 2009),(Zhu, 2009). Most of developed TPC protocol that work with MANETs cannot be compatible with WSNs as a result of mobility, battery lifetime limitation and transmission range.

(Gautam et al., 2011), proposed TPC mechanism (ETPCM) to conserve energy in mobile ad-hoc IEEE 802.11b sensor networks .the proposed protocol build on RSSI readings . Hence, the transmission power is adjusted based on estimated distance between mobile nodes and calculated values . The simulation results show that the proposed protocol can maintain throughput while reducing delay and jitter.

(Zhu, 2009), built his proposed TPC on radio transmission range protocol to minimize energy depletion. This protocol procedure depends on path loss model function and

the distance between sender-receiver nodes. The results show that energy saving was limited when using channel with increasing the hops' number, but significant advance in energy savings when using optimal transmitting range without considering maintaining throughput .

The Table 2.1 provides a summary of previous studies conducted to TPC protocols for wireless network communication.

Ref.	Approaches	Methods	Objectives	Key findings	Key gaps
(Kwon et al., 2006)	A cross-layer strategy based-TPC	Mathematics & Simulation	TP is adjusted based on channel gain	1. Enhance energy efficiency; 2. Prolong lifetime 3. Reliable connectivity	Throughput and network density
(Viswanathan, 2009)]	An adaptive link per-link TPC	Mathematics & Simulation	TP is adjusted based on link margin, data-loss rate and received signal strength	1. Enhance energy efficiency; 2. Avoid interference; 3. Enhance throughput	Network density
(Choi and Lee, 2014)	A distributed TPC	Mathematics & Simulation	TP is adjusted based on link quality for each hop	1. Enhance energy efficiency; 2. Improve throughput	Network density
(Lee and Chung, 2011)	ATPC	Hardware Experimental	Calculate the link quality based on the RSSI readings in open and closed-loop	1. Enhance energy efficiency; 2. Avoid extra overhead	Throughput and network density
(Kamarudin et al., 2010)	TPC with realistic radio energy model	OmNET++	TP is adjusted based on receiving power level and path loss factor	1. Enhance energy efficiency; 2. Prolong lifetime; 3. Avoid data collision	Throughput and network density
(Das and Chaki, 2011)	An optimal power balancing technique	Simulation	Select the next hop based on maximum residual energy	1. Enhance energy efficiency; 2. Prolong lifetime	Throughput and network density
(Messier et al., 2008)	Novel-CLPC	Optimization theory	Set MAC and MAI routing based on cross-layer of MAC and PHY	Enhance energy efficiency and network performance	Throughput and network density
(Gautam et al., 2011)	ETPCM	QualNet v5.0	TP is adjusted based on estimated and calculated RSSI reading	1. Enhance energy efficiency; 2. Improve throughput; 3. Reduce delay and jitter	Network density
(Zhu, 2009)	TPC	Simulation	TPC based on radio transmission range protocol and distance between nodes.	Limit energy saving. Significant enhancement in energy efficiency	Throughput not considered

Table 2.1 Summary of TPC protocol previous studies

2.6 Routing protocol in WSNs

Most of current multi-path routing protocols used in WSNs are based on single path routing but developed to use in multipath routing . when they used in single path , routing protocols has no consideration about data balance and data traffic because focus only on travelling data between source and destination nodes . data rate aggregation on single path routing is low and depend on return capacity limit (Huang et al., 2010). Single path routing protocols are not efficient for energy consideration approach and it is considered an efficient if it does not use all the available network resources . we can explain below some reasons lead single path routing protocols to be not efficient in energy consideration .

- In case of node failure , the establishment of new route will take more energy consumption (Lee and Choi, 2006).
- Security risk in single path routing protocols can be increase if a malicious nodes are intermediate nodes (Viswanathan, 2009).
- Congestion in single path lead to loss data and as a result , the power consumption increase (Chatterjee et al., 2002).
- In single path routing protocols , the same short path is always selected by protocol which lead to energy depletion for each node in the in the established path (Ming Lu and WS Wong, 2007), (Chen and Nasser, 2006).

As a results for the above points , we can note that single path routing is less than multipath routing in reliability because of the limitation in resources and interfaces in the environment and risk of malicious nodes .in other side , significant enhancement in reliability can be obtained when travelling data with multipath routing protocol.

In multipath routing protocols , if anode failure occur there is a chance to found a recovere or compromised path (Lee and Choi, 2006). One of the efficient points on multipath routing protocols used for establish multipath between source and destination pairs is tha node density (Mueller et al., 2004). The network must be dens enough to ensure the connectivity between nodes . the primary path in multi path routing protocols is used for data transmission ,

while the additional paths which discovered can be used to improve the network resources in cases of high traffic load , congestion and node or link failure which is used as fault tolerance

The following points represent some advantages of using multi-path routing protocols :

- Enhance the network reliability.
- Can be used as one of the solutions for network congestion .
- Support a service of quality of service .
- Provide fault tolerance service .

In WSNs , the battery lifetime , limited memory size and transmission range , represent challenge in developing multipath routing protocol which used for wireless network ad-hoc networks which not compatible with WSNs. This fact lead to develop multipath routing protocols compatible with WSNs.

Advantages of developing multipath routing protocols for WSNs

- Multipath routing protocols balance load traffic in alternative paths , this can play a role in compromise the problem of data traffic and congestion which lead to reduce the network performance(Gallardo et al., 2007), (Key et al., 2007). The enhancement of data traffic , preventing congestion and reducing the number of packets losses , will lead to enhance the energy consumption and prolonging the nodes battery and network lifetime. The use of shared channel in single path transmission cause increasing in probability of data collision occurrence , while using multi path transmission there is low chance of data collision if we compare it with single path transmission. in order to solve the problem of data collision and interference and to design efficient multipath routing protocol , there are various techniques including :
- multi-channel data transmission, which enhance network throughput and reducing the channel interference by channel switching technique (Tam and Tseng, 2007), (Subramanian and Buddhikot, 2006).
- Location aware , which proposed to minimise the overheads due to increasing number of application techniques (Wang et al., 2009), (Fu et al., 2009).

- Direct antenna , in this technique reducing the channel interference occurred (Roy et al., 2002).

Another consideration in multipath routing protocols which is Quality of service , Qos refer to network performance such as delay ,throughput , data rate and link capacity (Mueller et al., 2004) , (Lou et al., 2006). Multipath routing protocols maintain quality of service for the required applications. For example in multimedia the data stream is delivered and exchanged through link with high capacity and must in low delay paths because it is real time application , while in non real time application it can use a link with low capacity with high delay .

Some challenges faces the development of reliable data delivery in multipath routing protocols which are the resources limitation , node mobility and interference (Fonseca et al., 2007), (Kim and Shin, 2009).

In WSNs , data transmission in multipath routing protocols provides high flexibility against link or node failure because it use alternative paths which enhance the WSNs reliability . WSNs reliability enhancement can be done using two main methods , the first method by sending the same original data as copy in the alternative paths that discovered and connect between source and destination nodes . this method provides high reliability but consume the network resources . second method based on data-coding method , the source node adds some extra information to the original data and this lead to send the data in paths (routes) . the recovery of the original data that send from source will improve the data exchange from each node which enhance the data delivery in the network.

2.7 WSNs Multipath routing protocols classification

in this section of study , we will classify the multipath routing protocols used in WSNs. We focus on multipath routing protocols in WSNs because these protocols decrease the chance of interference and increase the throughput in most of cases. The figure 2.7 shows three categories of classification.

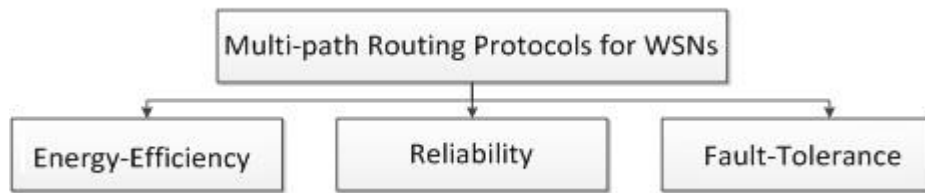

Figure (2.8) Classification of the multi-path routing protocols for WSNs.

2.7.1 Multipath routing protocols for energy efficiency

one of the most important studies has been proposed protocols to prolonging the battery life time . Trying to solve the problem of limited power in WSN nodes. The use of optimal paths in single path route increase the energy consumption for each sensor node. While using the multipath routing protocols will balance the data load traffic among alternative paths can prolong the network lifetime by sharing and balancing data traffic. Each path will carry smaller amount of data and in the same time will improve the throughput. Many studies proposed efficient multipath routing protocols.

By balancing data load traffic and to prolong the WSN lifetime . (Ming Lu and WS Wong, 2007). They proposed energy efficient multipath routing protocol (EEMR). This protocol is proposed to prolong WSN lifetime through balancing load among multipath routing . this protocol based on sending request to route RREQ message from source node. This message incorporate several paths . identification and establish multiple paths . all the intermediate nodes will select the optimal adjacent node to reach the destination node . the factors which considered to get priority between nodes as the next optimum node is the number of hop-count , distance between current to next node pairs and initial and remaining energy at each nodes .when the first RREQ message reach the destination node , the destination node will begin timer to decrease the route establishment time .

When the timer timeout, the path will assumed to be low quality path and neglected. By depending on the number of paths and each route cost, the destination after neglecting the low quality paths will calculate the data rate for other paths. Then will send assign message that

inform the source node by the value of data rate for each established paths. Source node will send its data stream among the paths which selected by destination.

(Radi et al., 2010), (Radi et al., 2012), Propose low interference energy efficient multipath routing protocol (LIEMRO). The proposed protocol designed to improve the performance in WSN by reducing interference . In LIEMRO, the establishment of primary path is done by source node depending on number of factors such as number of adjacent nodes, the residual energy in each node, interference level and the probability of success forward and pack word data recipient on each route based on link cost which is defined as ETX metric value. LIEMRO protocol results show an enhancement in WSN performance occurred by balancing the traffic load with dynamic route maintenance.

(Vidhyapriya and Vanathi, 2007) use load balancing to prolong the network lifetime and reducing power consumption and this lead them to propose Energy Adaptive Multimedia Routing Protocol (EEAMR). By distributing the data load over multipath depending on signal strength and residual energy. According to EEAMR , this will achieve the quality of power consumption in each node . the source node will select the path who has the highest residual energy and load the largest data traffic load on it , while the smallest residual energy path will get the smallest data traffic load .this will create uniform energy depletion in all paths .results of EEAMR show enhancement in power consumption in high density WSNs.

(Xiu-li et al., 2008) designed the Multi-path routing based on Ant Colony System (MACS) algorithm to identify the optimal primary path and optimal alternative paths between source-destination pairs to prolong network lifetime. The forward ant seeks for parallel multiple paths, and if the intermediate node has been visited, the ant ignores the marked node and searches for another. However, if the node has not been visited by another ant, the ant evaluates the adjacent node to the destination node and updates the pheromone table. The backward ants update the pheromone table by following the forward ant and establishing the optimal multi-path. The results showed that the MACS algorithm enhanced energy efficiency, network performance and network lifetime.

(Saleem et al., 2009), designed a Self-Optimised Algorithm using Multi-path Routing (SOAMR) protocol based on the Ant Colony Optimisation (ACO) approach for WSNs to provide the best throughput and avoid data congestion by balancing a traffic load between two or more paths. This protocol discovers the optimal path with a minimum energy cost route to determine the shortest multi-path based on various factors such as delay, receiving data rate and residual energy of the next-hop adjacent node. In the event that the optimal path is not identified, the procedure is repeated to establish other paths. The results identified that WSNs can aggregate high data throughput with reduction in the data loss rate. However, SOAMR protocol does not consider the effects of network density and traffic load of the active nodes.

2.7.2 Multi-path routing protocols for fault tolerance

Multiple path protocols provides fault tolerance mechanism by adding number of alternative paths . the node send data over multiple parallel paths , if one of these paths hacked or fail then the data continue reaching the destination through alternative paths .

(Intanagonwiwat et al., 2000), proposed a Directed Diffusion (DD) multi-path routing protocol to solve the problem of failure in node or link . in DD protocol , the destination node broadcast Interest message which exchanged between all intermediate nodes .Interest message continue all required information to establish multiple paths .the receiver node append the required data until reaching the source node after receiving Interest message . the DD protocol results show that the data delivery rate can be enhance while decreasing the delay interm of end –to-end . in case of node failure in the active path , the limitation on throughput because it uses single path for data relaying is one of the problems .

(Ganesan et al., 2001), proposed a Braided Multi-path Routing (BMR) protocol to provide fault tolerance in WSNs which has similar mechanism of DD protocol. Fig 2.9 shows a schematic diagram of BMR protocol.

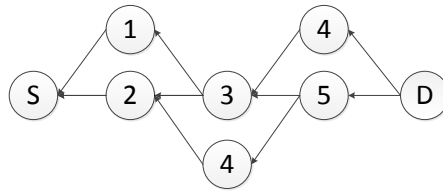

Figure (2.9) Schematic diagram of BMR protocol

In Fig 2.9, Node D transmits the primary path *Reinforcement* message to Node 5 which then sends the message to the next-hop until it reaches Node S. After that, Node S and the intermediate nodes along the primary path establish an alternative path around their next-hop adjacent node. Node D and intermediate nodes relay alternative path *Reinforcement* messages, which are broadcasted to the next-hop adjacent node to reach Node S. This leads to the establishment of a backup path. It can be found from the results of implementing BMR protocol that the energy cost of the alternative paths is dependent on the network density. However, the energy consumption is high due to the relatively high energy required to maintain the alternative paths. Since BMR was developed based on the DD mechanism; hence the limitations pertaining to DD are similar in BMR.

2.7.3 Multi-path routing protocols for reliability

Network reliability can be defined as the ratio between total sent data by source node to the received data in destination node .in single path protocols , low reliability only can be achieved because of the risks of node failure and link failure .the recovery in single path protocols done slower than in multipath routing protocols and it consume power . in multipath routing protocols , high reliability can be achieved by transmitting data through number of alternative paths. Also , in multipath routing protocols the mechanism of link or node failure is done easily and faster than in single path protocols . There are several studied that deals with WSNs power consumption through enhancing the network reliability.

(Lou and Kwon, 2006) ,proposed a hybrid multi-path (H-SPREAD) protocol for secure and reliable data collection by employing a combination of the N-to-1 route establishment mechanisms and a hybrid multi-path routing mechanism for WSNs. In H-SPREAD, the original

data copy can be sent to reach the destination node which shared by other nodes when the original ones or links fail. This protocol incorporates the N-to-1 routing protocol to establish multiple paths leading to an increase in the interference. However, a high level of data loss-rate occurs as a consequence of interference, causing a reduction in the data delivery rate. H-SPREAD consumes more power when exchanging secured data in alternative paths, as well as it does not balance the data traffic load.

(Ben-Othman and Yahya, 2010), developed a Multi-Constrained *QoS* Multi-Path (MCMP) routing protocol to enhance reliability and reduce delay. mechanism of MCMP begin when each node chose group of adjacent nodes which can improve network reliability and then each selective nodes establish number of paths through these selected nodes .several copies of data that needed to transmit to the destination will be sent through intermediate nodes sub paths. However, in the MCMP protocol, intermediate nodes identify the set of their adjacent nodes that meet the reliability and delay related to the data source, which disregards power use in the transmitting mode over each path.

(Bagula and Mazandu, 2008) . Developed an Energy Constrained Multi-Path (ECMP) routing protocol. This protocol aimed to improve MCMP routing protocol by reducing power consumption.

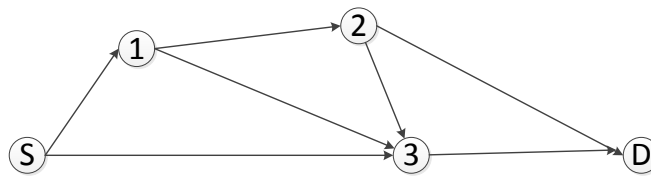

Figure (2.10) ECMP mechanism

As shown in Fig 2.10, the distance between Node S and Node 1 is short if compared with the distance between Node S and Node 3. The necessary energy to send data is dependent on the distance between the transmitter-receiver pair. The energy consumption of Node S is minimised by selecting Node 1 as the distance is shorter than Node 3. The results showed that MCMP and

ECMP achieved equivalent delay and data delivery rates. Conversely, ECMP consume lower energy than MCMP protocol, but both of these protocols fail to account for WSN throughput.

(Ben-Othman and Yahya, 2010) designed an energy-efficient *QoS*-based multi-path routing (EQSR) protocol. This protocol applied for real-time applications to enhance the reliability and reduce the end-to-end delay. EQSR mechanism contains five steps as follow:

1. Destination node broadcast HELLO messages to all nodes in the WSN. During that, each sensor node gathers information related to the route cost.
2. Using some variables such as residual energy level, buffer capacity and the SNR level by intermediate nodes to identify the most appropriate next-hop adjacent node to reach the source node.
3. Step 2 is rendered continually at the intermediate nodes until a *RREQ* message reaches the source node and establishes a primary path.
4. The destination node constructs extra alternative paths by broadcasting *RREQ* messages to adjacent nodes. Choosing Optimal paths based on the data delivery probability at all multi-path routes.
5. Final step, the source node balances its data traffic load through the selected paths, based on their delay.

The results show that EQSR minimises end-to-end delay and enhances reliability. Nonetheless, the function of routing costs limits the number of paths with minimum interference levels.

Table 2.2 Summary of multi-path routing protocols for WSNs

Field	Protocols	Based-on	Energy Consumption	Traffic Load	Reliability	fault-tolerant	No of paths	Maintain /Recover
Multi path routing protocol for Energy efficiency	EEAMR	-	Limited	Balanced	Yes	No	-	M
	LIEMRO	-	Limited	Balanced	Yes	No	-	M
	EEMR	-	Limited	Balanced	Yes	No	-	M
	MACS	ACO	Limited	-	-	No	-	-
	SOAMR	ACO	Limited	-	Yes	No	2	-
Multi path routing protocol for Fault tolerance	DD	-	Limited	Unbalanced	No	Yes	-	M ¹
	BMR	DD	Limited	Unbalanced	No	Yes	2	M
Multi path routing protocol for Reliability	H-SPREAD	N-to-1	-	Balanced	Yes	No	-	-
	MCMP	-	High	Unbalanced	Yes	No	-	-
	ECMP	MCMP	Limited	Unbalanced	Yes	No	-	-
	EQSR	-	Limited	Balanced	Yes	Yes	-	-

¹ M stands for path maintenance

CHAPTER THREE

METHODOLOGY

3.1 Introduction

This chapter implement mathematical approach and graph theory to discuss number of different scenarios. The final goal is to formulate general equations for power consumption and throughput for uniform wireless sensor network. And to applying the equations under the WSN condition assume it. Will begin with overall methodology and next discuss the effect of increasing the number of hops on energy saving and obtain mathematically an equation for calculating power consumption .Then will discuss some cases of adding paths to maintain the network throughput.

3.2 Overall methodology

As shown in figure (3.1) , this chapter begin with network model assumptions to find equations that used to minimize the power consumption and maintain throughput.

3.2.1 Network model assumptions:

1. The distances between nodes are equal. This assumption of arranging nodes is widely used for many fields such as agriculture environment sensing or temperature or wind sensing ...etc.(Zhu, 2009)
2. Network nodes exchange information through equal packet size. This equal packet size can be used because each sensor nodes will only send parameters in fixed size packet of the data send by nodes are parameters.(Meghji and Habibi, 2011b)
3. Each (fixed size packet) take the same amount of time period to travel from node to another (neighbour node).

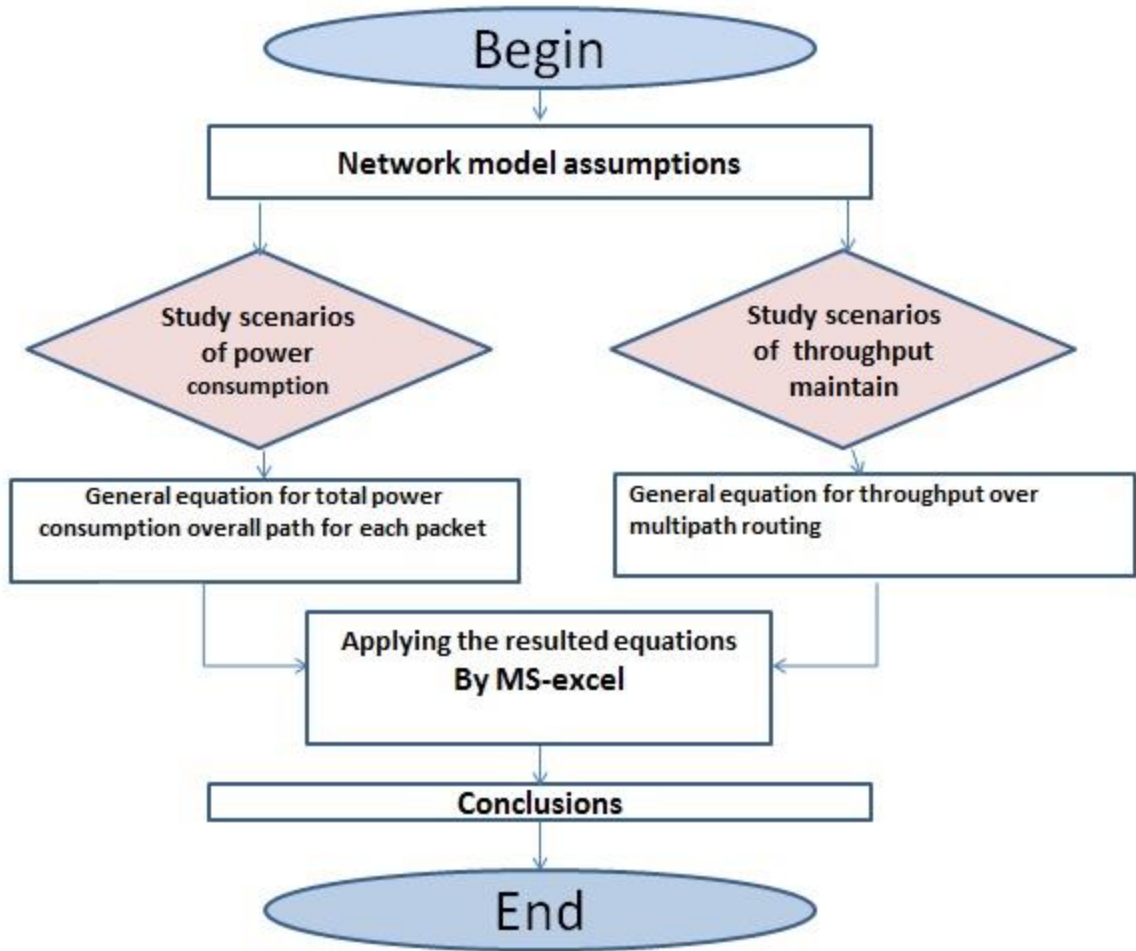

Figure (3.1) (steps of methodology)

4. Packets are crossing their way from source to destination through more than one path.
5. Propagation delay not considered in calculation.
6. The distance between nodes is small, no more one time slot required to send packets from node to neighbour node.
7. The network density is enough to use routing protocol and so multi-path topology.
8. Transmission range of each single transmitter and single channel sensor node is variable and it can use the minimum transmission power.
9. Each sensor node has an identity and has Omni directional antenna with free space propagation model.
10. sensor nodes are adjustable transmission power channel.
11. All timeslots are equal in period.
12. Each sensor node has the ability to send or receive a packet at a time, and cannot do both operations in the same time (based on our previous assumption, we use single channel/single transceiver). This will reduce both power consumption rate and cost .
13. We will assume the worst case of interference; if any node interfered by another node it will stop receive or send a packet.

3.2.2 Case study summery

This chapter will study several scenarios to reach the final equations used to decide the suitable number of hops and paths to build topology that prolonging the network life time and maintain throughput. Table 3.1 represent the summery of scenarios are studied in power consumption side and the result from scenarios are studied to maintain throughput and to obtain the final general equations.

Scenario	Hob number	Paths number	power consumption	Troughput equation
1	1	1	$100\% * P_{max}$	$T= N/t$
2	2	1	$50\% * P_{max}$	$T= N/2N$
3	2	2	$50\% * P_{max}$	$T= N/2N$
4	2	3	$50\% * P_{max}$	$T= N/2N$
5	2	4	$50\% * P_{max}$	$T= N/2N$
6	3	1	$33\% * P_{max}$	$T=N/(2N+1)$
7	3	2	$33\% * P_{max}$	$T=N/(N+2)$
8	4	1	$25\% * P_{max}$	$T=N/(2N+2)$
9	4	2	$25\% * P_{max}$	$T=N/(N+3)$

Table (3.1) (summery of scenarios study)

Note :

P_{max} : the maximum power that node can use to send packet

N: number of packets

t: number of time slot used to complete data transition .

3.3 study of scenarios

We will study some cases of regular transmission power control. In these studies, we will adopt that the sensor nodes are connected wirelessly and deployed randomly in a specific area.

First case represents transmitting data by setting maximum power level from source (S) to destination (D) will cause crossing the area in one path as shown below in Fig 3.2.

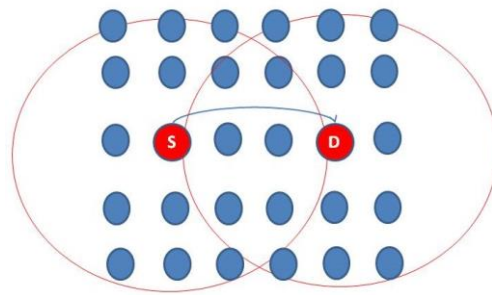

Figure (3.2) Single path/single hop topology

This topology gives some details:

- Maximum power consumption.
- Maximum energy depletion (low battery lifetime).
- Throughput is neutral.
- Single path routing.
- Single hop topology.
- Maximum interfering area as noted above in Fig 3.1, that shows 8 interfered nodes with sender and receiver nodes.

Second case represents multi-hop/multi-path topology as shown below in Fig 3.3.

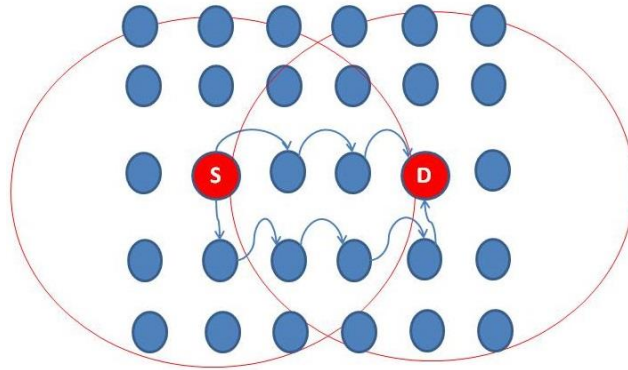

Figure (3.3) Multi-hop/multi-path topology.

This topology gives some details:

- Less power consumption.
- Less individual energy depletion.
- Few throughputs lose.
- Multi-path routing.
- Multi-hop topology.
- Narrow interfering area as noted above in Fig 3.3.

In network model assumptions assumes that the hops divide the paths equally. Note that the crossing to the destination was completed by two paths and variable number of hops at each path. This topology can reduce transmission power but that also means the intermediate hop needs to retransmit the packets those were received again. Behinds, we know that *the power consumption is related to the inverse square or higher with distance (depending on frequency)*, that will leads to reducing transmitting power to the *specific ratio of maximum* value that necessary to send same data by multi-hops topology. So, we can gain an energy saving while we divide the path to multi-hop technique. Therefore, the worst case is the throughput as it will be reducing to half (case of one hop). Because of the data is being sending twice, we think this can be covered if the network assigns two paths only(Abduljaleel et al., 2009) Moreover, reducing power consumption can significantly extend the battery lifetime which is important for WSNs.

this section will use mathematics and graph approaches try to find the general formula for power consumption for each transmission node . the second part will approve the required number of paths that maintain throughput .

3.3.1 Effect of increasing number of hops on consuming power

This section discuss the effects of increasing paths number on the total power consumption for each packet (P_T).To calculate the total transmitting power, we will classify our study as:

First part: as shown in Fig 3.4, we will study the effects of being single path/single hop topology.

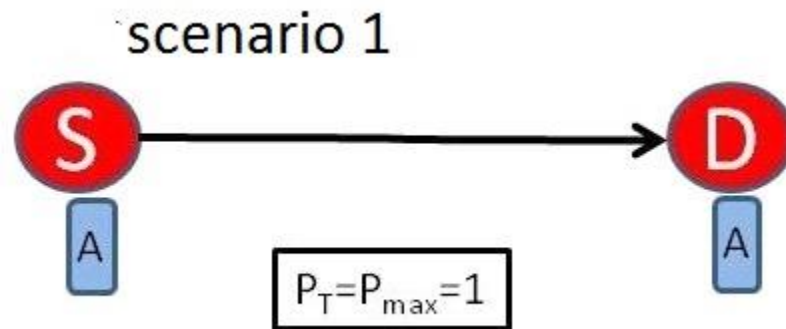

Figure (3.4) Single hop/single path topology study.

scenario 1, presents sending packet (A) from source (S) to destination (D), the topology is used as single path with no intermediate nodes in regular transmission range.

Second part: we will study the cases of sending no. of packets through two hops in multi-path topology. Assuming no propagation delay between nodes. (As shown in Fig 3.5, **scenarios 2, 3, 4 and 5**).

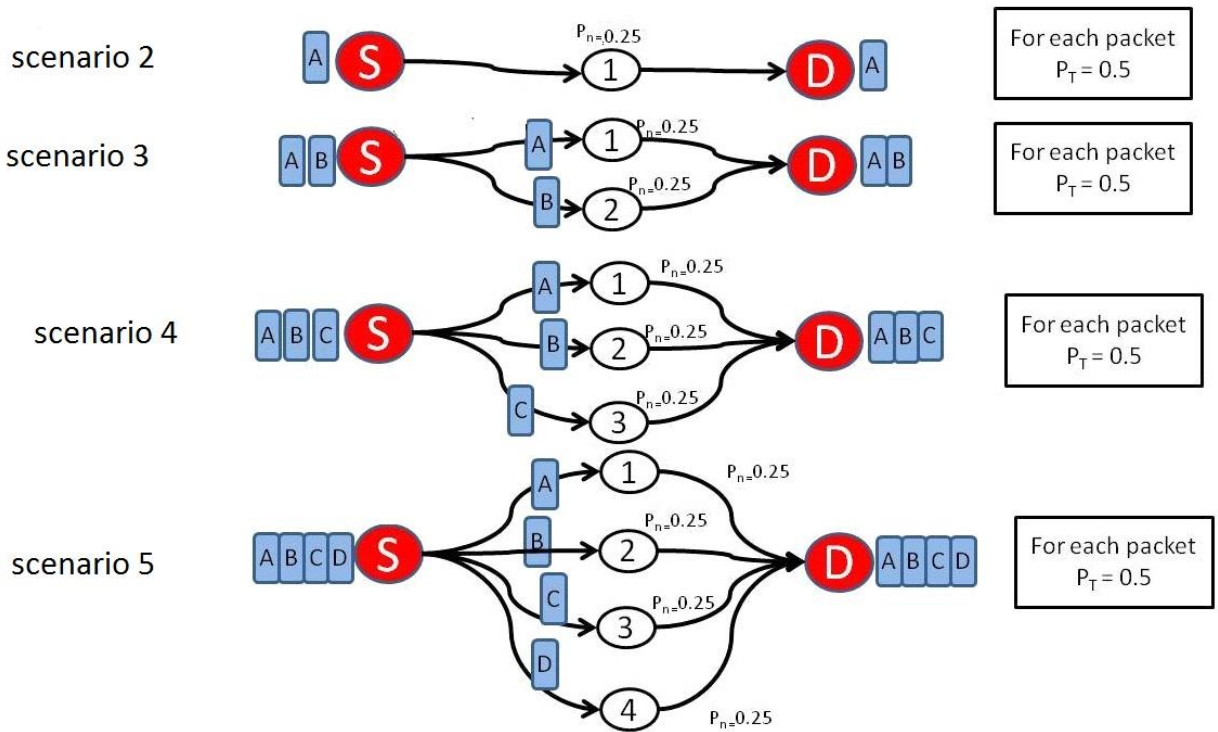

Figure (3.5) Two hops with single and multi-paths topologies.

In **scenario 2**, we send packet (A) on single path with two nodes topology (halving the range equally)

$P_{tx}(n)$ (relative power consumption for each node) = 0.25 because as we know that power is relative with *square of distance* which is halved by intermediate node. Then, the total power consumption for each packet is equal to $(0.25+0.25=0.5)$ of P_{max} .

scenario 3 represents sending packet (A), (B) to destination in two paths topology, each path is halved by one intermediate node. For any packet that selects any path to transfer data from source (S) to destination (D) the relative total power consumption equal to: $0.25+0.25 = 0.5$

scenario 4 represents sending packets (A, B and C) through 3 paths; each path is halved by one intermediate node. We note that the relative power consumption at each node equal to 0.25 for each packet, so the total relative transmitting power equal to $(0.5 P_{max})$.

scenario 5 shows sending packets (A, B, C and D) through 4 paths, each path is halved by one intermediate node.

The same results as previous cases (**scenario 3 and 4**), can conclude from that There are no effects from increasing the no. of paths with constant no. of intermediate nodes because each packet will consume the same relative total power of transmitting, and so that **two paths is enough** to test the effects of increasing no. of intermediate nodes, this will apply in third and fourth parts when we study the effects of increasing no. of intermediate hops in power consumption.

Third part, send no. of packets in single and multiple path transmission topologies with two intermediate nodes and study the effects of this change of topology on consuming power (scenario 6 and 7, Fig 3.6).

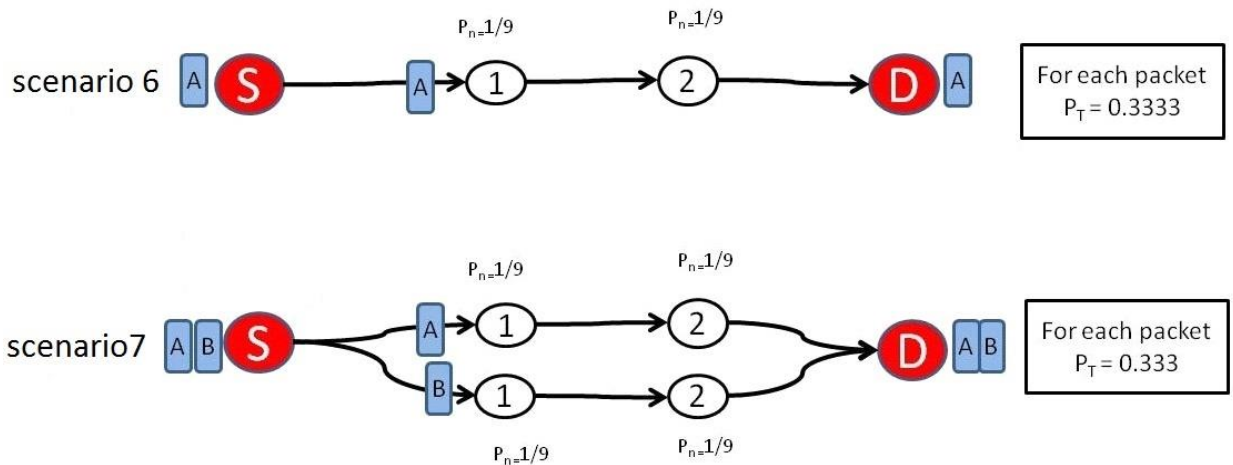

Figure (3.6) Two hops with single and two paths topologies.

Scenario 6 shows sending one packet on (single-path, two intermediate nodes) topology, the transmission range is divided equally; we note that the relative total power consumption can be calculated and the result is:

$$1/9+1/9+1/9= 1/3$$

Scenario 7 represents sending two packets in (two paths, two intermediate nodes) transmission range, the transmission range is divided equally, we note that the relative total power consumption for each packet takes any path can be calculated and the result is :

$$1/9+1/9+1/9= 1/3$$

The results are achieved was similar to the second part.

Forth part, we will study the effects of increasing the no. of intermediate nodes to three with single path and two paths as shown in Fig 3.7.

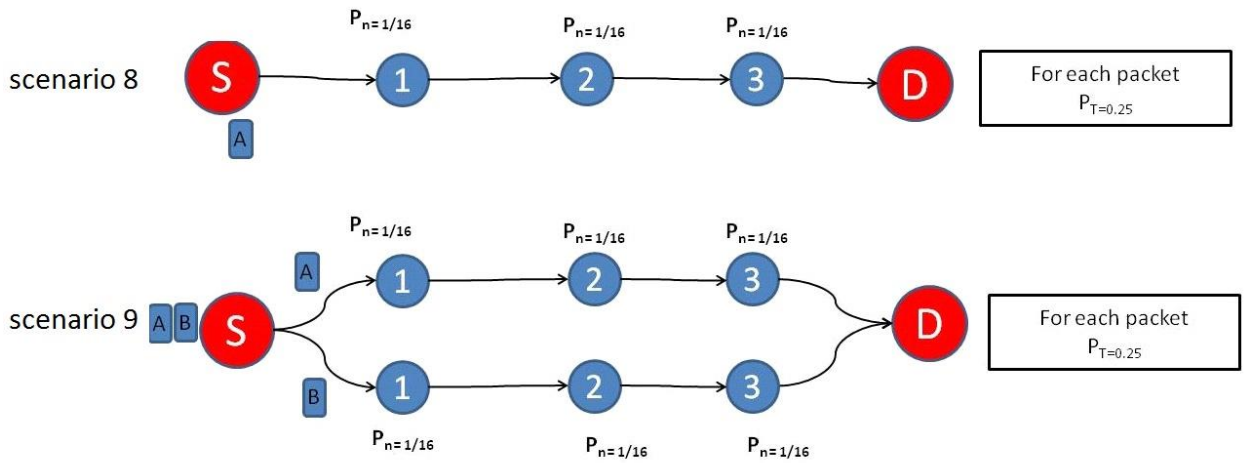

Figure (3.7) Three hops with single path and two paths topologies.

Scenario 8 represents sending one packet on (single path, three intermediate nodes) topology, the transmission range is divided equally; we note that the relative total power consumption can be calculated and the result is:

$$1/16+1/16+1/16+1/16= 1/4$$

Scenario 9 represents sending two packets in (two paths, three intermediate nodes) topology, the transmission range is divided equally; we note that the relative total power consumption for each packet takes any path can be calculated and the result is:

$$1/16+1/16+1/16+1/16= 1/4$$

By reaching to fourth part, we note that there are improvements of 75% of maximum consuming power if we send a packet in single path single hop topology with maximum transmission power.

Finally, we can conclude that the power consumption in multi-hop topology can be reduced effectively when the number of intermediate hops is increased, and the effects of no. of paths does not appear over two paths transmission route. So, that we can build our study based on two paths with variable no. of intermediate hops.

From the previous graphs , the maximum power consumption (P_{max}) with the distance ratio (d) and the path loss exponent (α) which assumed to be under the free space propagation and equal to (2). (Al-Hamdany and Raad, 2014) The equation to find power consumption at each node (P_n) shown below (**as shown in section 2.3**):

$$P_n = P_{max} d^\alpha \quad \text{Eq. (3.1)}$$

Where :

P_n : relative power consumption at each node

d: distance ratio.

(α) :path loss exponent

h: no. of hops.

n: no. of nodes.

When $\alpha = 2$, and $d = 1/h$, we can generalize the equation to be:

$$P_n = (1/h)^2 P_{max} \quad \text{Eq (3.2)}$$

And for total power consumption for each packet (P_T):

$$P_{T= n} = \sum P_{tx}(n) + \sum P_{rx}(n) \quad \text{Eq. (3.3)}$$

Where:

$P_{tx}(n)$: total relative consumed power of transmitting on n nodes

$P_{rx}(n)$: total relative consumed power of receiving on n nodes

n: no. of active nodes on transmission range

power of receive $P_{rx}(n)$ for each node is constant and small value which can be ignored,

$$P_T = \sum P_{tx}(n) \quad \text{Eq.(3.4) (relative total power consumption at each transmission node)}$$

3.3.2 Maintaining Throughput in wireless sensor networks

To study the throughput in WSNs, it is important to consider various studies based on the change of no. of paths and hops. And analyse the predicted result according to the general equations. Before we start to sketch the graphs and calculate effects of parameters (paths and hops number) on throughput, we must clarify network model conditions as well as terms and parameters that we will be needed in the next section:

Throughput, $T = N/t$

Where: N: no. of packets, t: total time, t_s : no. of timeslots, h: no. of active hops .

We will compare the effects of increasing number of paths on throughput with (1 and 2) hops.

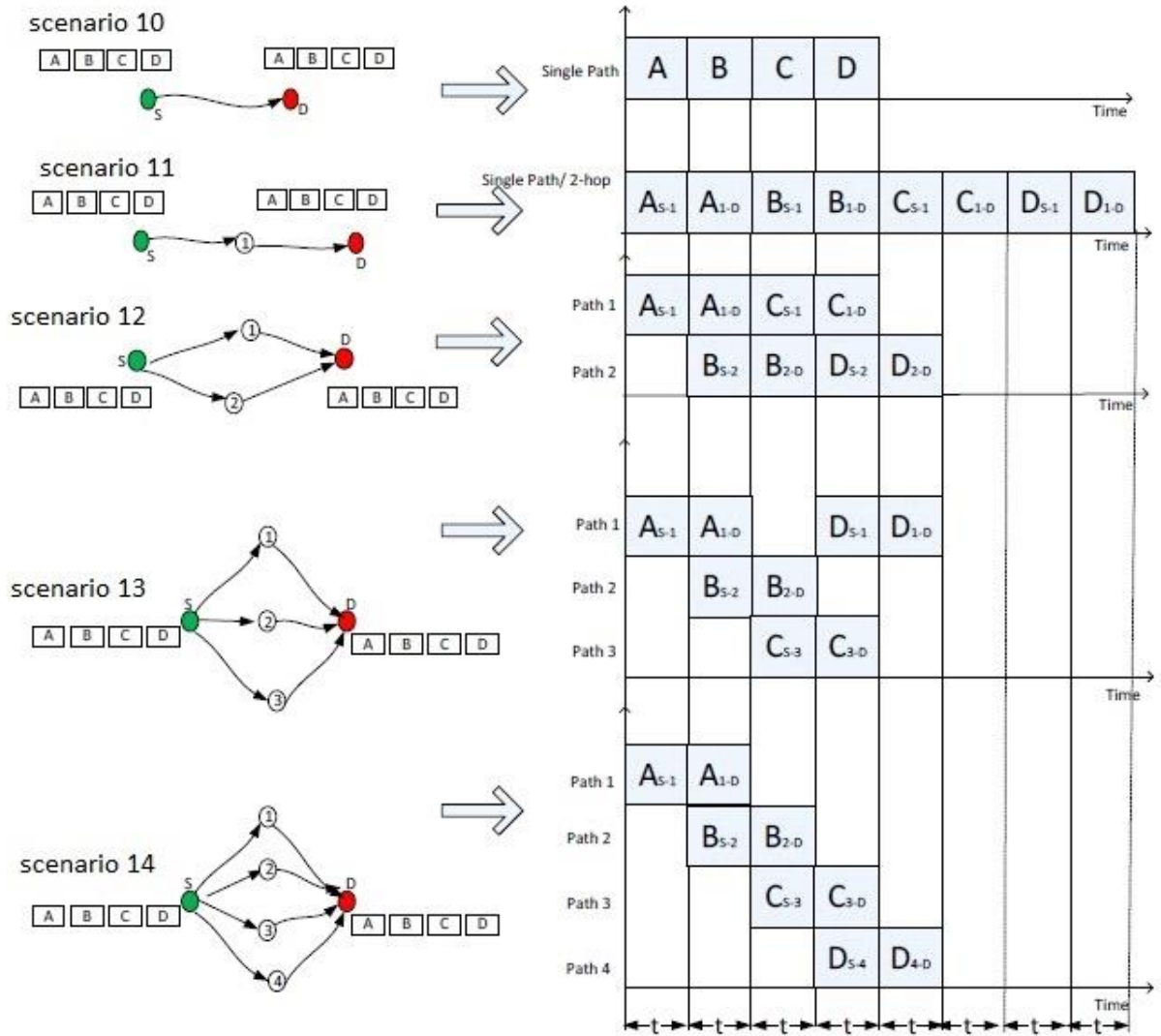

Figure (3.8) (Single hop/single path) and (2 hops/ multi-paths) topologies.

In Fig 3.8, **scenario 10**, we send 4 packets (A, B, C and D) in (single-path/single-hop) topology, we can calculate throughput from general equation of throughput as any packet need (one timeslot only) as below:

$$T = N/t = 4/4 = 1$$

Eq.(3.5) General equation for single path, single hop

We note that maximum throughput is (100%).

As shown in **scenario 11**, change the no. of hops to (2) and send 4 packets in single path topology. We note that any packet needs 2 timeslots to deliver from source to destination, so:

$$t = 2 t_s = 2N$$

And from equation of throughput, we can calculate that:

$$T = N/t = (4/2) = 0.5 \text{ (halved throughput).}$$

We can generalize an equation for throughput in (single path, two hops) as:

$$T = N/2N$$

Eq(3.6) General equation for single path, two hops

Scenario 12,13 and 14 (Fig 3.8), show that sending 4 packets in (2, 3 and 4 paths, two hops) topologies. Because the problem of *bottleneck* in sender and receiver, throughput of single channel sensor node cannot increase with increasing no. of paths because we using single channel sensor, this problem can be solved by using expensive multi-channel sensor nodes. Also, we note that each case takes ($t=N+1$)

So, we can generalize an equation for (2hops, multipath) topology as:

$$t = t_s (N+1) = N+1$$

$$T = N / (N+1)$$

EQ. (3.7) General equation for multipath, 2 hops.

We can *conclude* from scenario12,13 and 14 (Fig 3.8) the following:

There are no effects from increasing the no. of paths with constant no. of intermediate nodes because each packet will spend the same timeslot, and so that ***two paths is enough*** to test the effects of increasing no. of intermediate nodes, this will apply in next studies.

Then will compare (three hops, single path) topology with (three hops, multi-path) topology as in Fig 3.9.

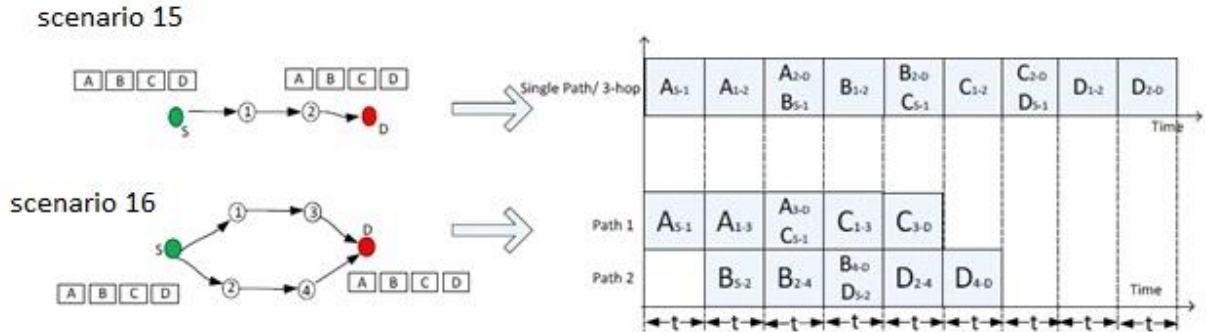

Figure (3.9) Three-hops in single path and multiple paths topology

In **scenario 15**, we study of traveling 4 packets through single path, three hops, we note that each packet needs three time slots to reach destination .then we can formulate the general equation of throughput

$$t = t_s (2N+1) = 2N+1$$

$$T = N/(2N+1)$$

Eq. (3.8) General equation for single path, 3 hops

Scenario 16 presents sending 4 packets through (three hops, multi paths) topology; we can begin from 2 paths: We note that t spent 6 timeslots to send 4 packets

$$t = t_s (N+2) = N+2$$

$$T = N/(N+2)$$

Eq(3.9) General equation for multipath, 3 hops

Then will send 4 packets in single path and multipath with 4 hops topologies as shown in Fig 3.10:

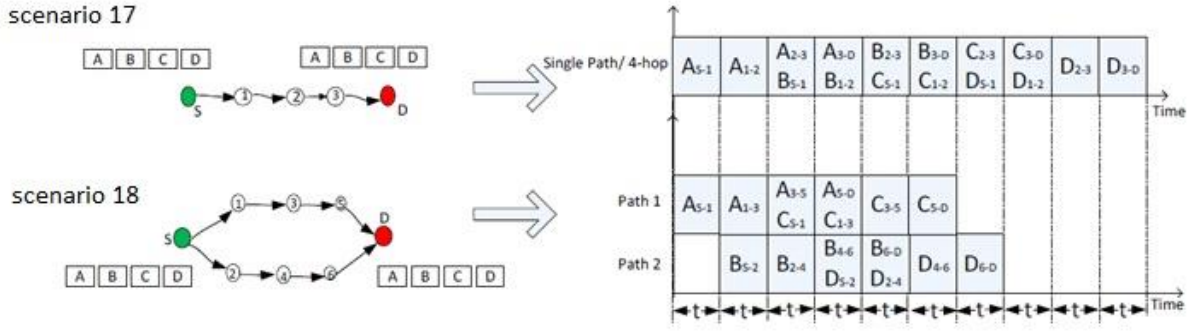

Figure (3.10) Four-hops in single and multiple paths topologies

Now, we can compare the results from sending data through (single path/four hops) and (multipath/four hops) topologies and write equations for both topologies.

In **scenario 17**, sending 4 packets through four hops, single path topology, we note that each packet needs to 4 timeslots at least to reach destination, so :

$$t=t_s (2N+2)$$

$$T= N/(2N+2)$$

Eq. (3.10) General equation for single path, 4 hops

In **scenario 18**, multi-path consists of two paths with four hops topology, from Fig 3.10, we note the optimal case sending these 4 packets need to :

$$t = t_s (N+3)$$

$$T = N/(N+3)$$

Eq. (3.11) General equation for multipath, 4 hops

We note that throughput is inversely comparative with number of active hops used in link between source and destination with multipath topology (more than one path).

From the previous four hops, if we assume that (h) is the number of hops while ($h \geq 2$), we can generalize a formula for throughput equation for single path topology according to Equations 3.8, 3.10 and 3.12.:

$$T = N / [2N + (h - 2)] \quad \text{Eq. (3.12) General equation for single-path, multi-hop topology}$$

Besides, we can generalize a formula for throughput equation for multiple paths topology according to Equations 3.7, 3.9 and 3.11.:

$$T = N / [N + (h - 1)] \quad \text{Eq. (3.13) General equation for multipath, multi-hop topology}$$

3.4 Conclusions

One of the goals we reach in this chapter is that we conclude the general equations for throughput and power consumption. As a result of utilizing multi-hop topology to minimize energy depletion and control the transmission data, raising the hops' number will decrease data throughput. This is due to the data store and forward actions that did by each sensor node in the network. The proposed solution for this problem is a multi-path topology to maintain throughput and keep it neutral. The proposed solution can be achieved by combining these two topologies (i.e. multi-hop and multi-path) in unique algorithm to minimize the disadvantages of using each technique separately. Consequently, the projected algorithm requirements to entail both optimal transmission power control to minimize energy consumption, and the multi-path routing protocol to keep throughput and lose neutral (at least two paths). From previous findings, the optimal number of hops must be minimum (such as 3 hops for each path) in order to reduce total power consumption. In other words, throughput is maintained while the two-paths are used and no enhance is obtained if utilizing more than two, this is because of the limitation of the single radio channel, and the number of packets goes to infinity (i.e. $N = 1000$ packets as it normally used in WSNs).

CHAPTER FOUR

RESULTS AND DISCUSSION

4.1 Introduction

From the result obtained from chapter three. conclude theoretically the fact that two paths transmission path topology is enough to maintain the throughput that has been reduced when using multi hops transmission path to reduce power consumption . this resulted from the bottleneck problem that neglect the effect of increasing the path number on increasing throughput . as assumed before that the nodes in our WSN model are single channel transmitter / receiver .in this chapter will simulate this resulted equations under the WSN model conditions assumed in previous chapter to find the suitable number of hops that achieve the maximum saving in transmission power. And reach to a topology can be used with TPC protocol combining with multipath routing protocol .

4.2 Power consumption graphs

Known that each intermediate node is either receiving packets or resend to the neighbour node to reach destination. We can assume the receiving power is constant and small value from the node's maximum transmission power and assumed to be neglected an calculations

. by applying equation (3.4) which represent the total power consumption for each packet transferred from sender to destination . We will change the number of hops from single path transmission range up to twelve intermediate nodes under the condition of free space propagation ($\alpha=2$).

Number of hops	Total power consume for each packet ($P_T = \sum P_{tx}(n)$)
1	100.00
2	50.00
3	33.33
4	25.00
5	20.00
6	16.66
7	14.28
8	12.50
9	11.11
10	10.00
11	9.10
12	8.33
13	7.69
14	7.14

The table (4.1) Results of equation (3.4)

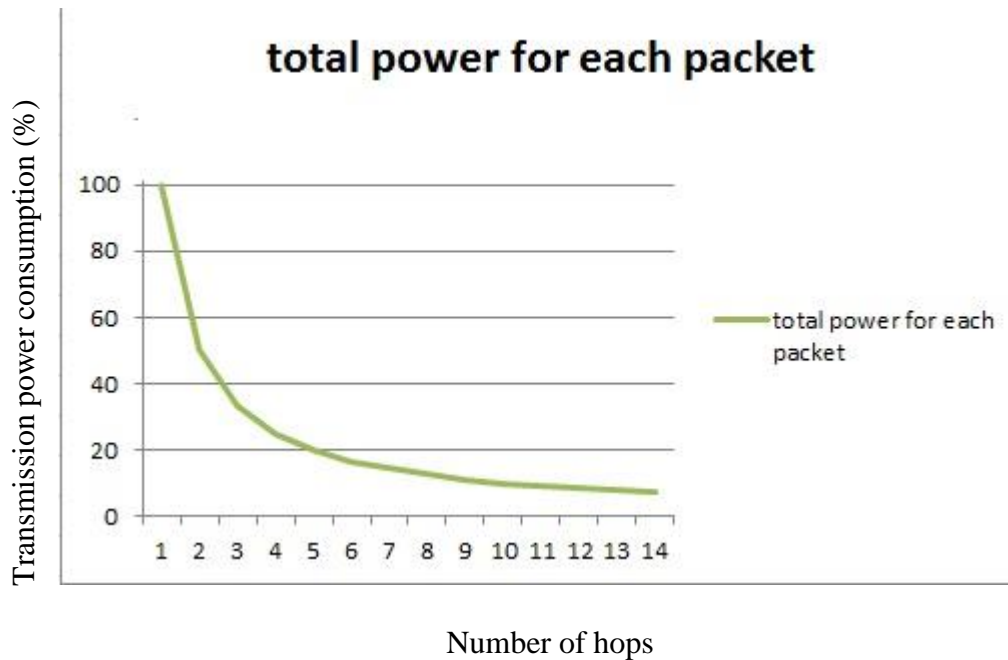

Figure 4.1 total power consumption for each packet with ($\alpha=2$).

From the table (4.1) we note that the suitable number of hops that achieve the maximum power saving for each packet among transmission range is between (2 -6) hops because there is not effective decrement in total power consumption when we increase the number of hops over six hops and this will be very costly comparing with the amount of saving the power . This fact can be achieved in any TPC protocols combining with multipath routing protocols with free space propagation condition and uniform WSN nodes.

4.3 throughput graphs

The result of chapter three concludes the general equation of throughput in case of multipath and multi hops topology. We apply this general equation with our result about suitable number of intermediate hops which (2 to 6) hops, the result appear in the figure below (fig. 4.2) which represent multipath transmission range throughput. And in the table (4.2) show the mathematical results we reach it.

number of packet N	Multipath throughput					
	single hop	two hops	three hops	four hops	five hops	six hops
1	1	0.50	0.33	0.25	0.20	0.16
2	1	0.66	0.50	0.40	0.33	0.28
3	1	0.75	0.60	0.50	0.42	0.37
4	1	0.80	0.66	0.57	0.50	0.44
5	1	0.83	0.71	0.62	0.55	0.50
6	1	0.85	0.75	0.60	0.60	0.54
7	1	0.87	0.77	0.70	0.63	0.58
8	1	0.88	0.80	0.72	0.66	0.61
9	1	0.90	0.81	0.75	0.69	0.64
10	1	0.90	0.83	0.76	0.71	0.66
11	1	0.91	0.84	0.78	0.73	0.68
12	1	0.92	0.85	0.8	0.75	0.70
13	1	0.92	0.86	0.81	0.76	0.72
14	1	0.93	0.87	0.82	0.77	0.73
15	1	0.93	0.88	0.83	0.78	0.75
16	1	0.94	0.88	0.84	0.80	0.76
17	1	0.94	0.89	0.85	0.80	0.77
18	1	0.94	0.90	0.85	0.81	0.78
19	1	0.95	0.90	0.86	0.82	0.79
20	1	0.95	0.90	0.86	0.83	0.80
21	1	0.95	0.91	0.87	0.84	0.80
22	1	0.95	0.91	0.88	0.84	0.85
23	1	0.95	0.92	0.88	0.85	0.82
24	1	0.96	0.92	0.88	0.85	0.82
25	1	0.96	0.92	0.89	0.86	0.83
26	1	0.96	0.92	0.89	0.86	0.83
27	1	0.96	0.93	0.90	0.87	0.84
28	1	0.96	0.93	0.90	0.87	0.84
29	1	0.96	0.93	0.90	0.87	0.85
30	1	0.96	0.93	0.90	0.88	0.85
31	1	0.96	0.93	0.91	0.88	0.86
32	1	0.96	0.94	0.91	0.88	0.86
33	1	0.97	0.94	0.91	0.89	0.86
34	1	0.97	0.94	0.91	0.89	0.87
35	1	0.97	0.94	0.92	0.89	0.87
36	1	0.97	0.94	0.92	0.90	0.87
37	1	0.97	0.94	0.92	0.90	0.88
38	1	0.97	0.95	0.92	0.90	0.88
39	1	0.97	0.95	0.92	0.90	0.88
40	1	0.97	0.95	0.93	0.90	0.88

41	1	0.97	0.95	0.93	0.91	0.89
42	1	0.97	0.95	0.93	0.91	0.89
43	1	0.97	0.95	0.93	0.91	0.89
44	1	0.97	0.95	0.93	0.91	0.89
45	1	0.97	0.95	0.93	0.91	0.90
46	1	0.97	0.95	0.93	0.92	0.90
47	1	0.97	0.95	0.94	0.92	0.90
48	1	0.97	0.96	0.94	0.92	0.90
49	1	0.98	0.96	0.94	0.92	0.90
50	1	0.98	0.99	0.94	0.92	0.90

Table 4.2 (throughput resulted multipath routing with variable number of hops)

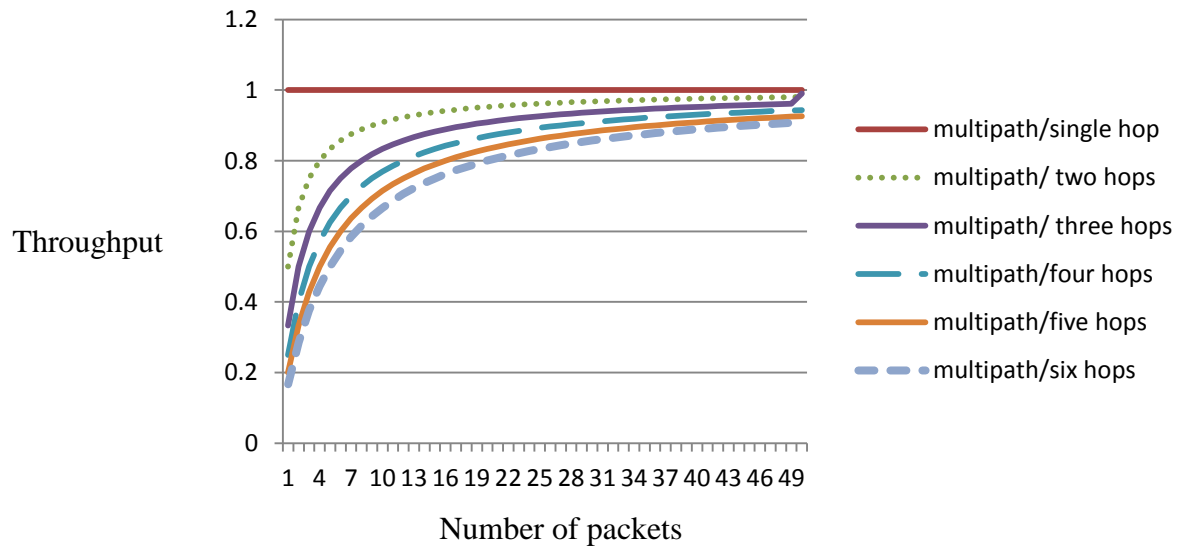

Figure (4.2) throughput of multipath / multi-hop

From the previous results in table 4.2, we note that the suitable number that maintain the throughput in multipath topology can be achieved when we set only two paths transmission range under our WSN nodes condition we assumed before . because if we use single path topology the throughput will be halved because of use multi hop transmission path.

Another note we can show it clearly is that the increase in data stream will result a natural throughput and the loss in throughput only appear in low data transmission.

Depending on the result obtained previously, the following table (4.3) represent the effect on increasing number of hops from using single hop to eight hops transmission path on both power consumption and network throughput assuming that using multipath topology (two paths) and sending two packets to obtain the number of hobs that related to minimum power consumption with maximum throughput.

number of hops h	(power consumption for each packet /100)%	throughput for multipath topology
1	1	1
2	0.25	0.66
3	0.11	0.50
4	0.06	0.40
5	0.04	0.33
6	0.02	0.28
7	0.02	0.25
8	0.01	0.22

Table 4.3 relation between number of hops with power consumption and network topology

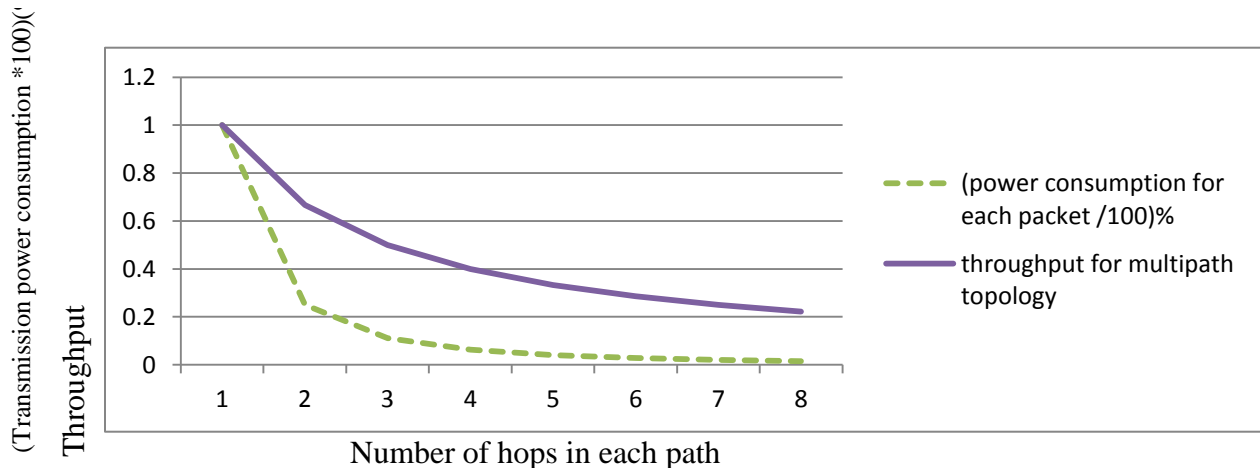

• • **Figure 4.3 power consumption with throughput with different hop number**

From the graph (4.3) note that in multipath topology, increasing number of hops will reduce transmit power consumption but throughput decreasing also. The suitable number of hops that required is decided depending on required ratio of power consumption decreasing and network throughput neutralizing.

CHAPTER FIVE

CONCLUSIONS AND RECOMMENDATION

5.1 Conclusions

After we apply the equations we obtain in chapter three , we can conclude the following facts :

- To reduce power consumption of any packet in WSN, we can divide up the transmission path to (2 to 6) hops, this will reduce the throughput.
- To maintain the throughput, we must apply multipath topology and the number of paths proved mathematically those two paths only is enough to reach this goal under the WSN model we assumed.
- This conditions can be applied with ant TPC protocols with multipath routing protocols to reduce power consumption and maintain throughput.

5.2 Recommendations

Although, this thesis has tried to find the suitable topology for WSN designed according some conditions it may be difficult to apply in all practical fields. So we recommend the following .

- Discuss the equations if multi channels sensor nodes Because the exchange of data has become more firmly.
- Apply the resulted topology on real life environment, elimination. Simulation.
- Consideration other parameters (reliability , delay effect of multi-hops)

Reference

- ABDULJALEEL, U., AKBARI, A. & KHATUN, S. 2009. An adaptive energy efficient protocol in media access control.
- ADYA, A., BAHL, P., PADHYE, J., WOLMAN, A. & ZHOU, L. Year. A multi-radio unification protocol for IEEE 802.11 wireless networks. *In: Broadband Networks, 2004. BroadNets 2004. Proceedings. First International Conference on, 2004. IEEE, 344-354.*
- AKKAYA, K. & YOUNIS, M. 2005. A survey on routing protocols for wireless sensor networks. *Ad hoc networks, 3, 325-349.*
- AL-HAMDANY, U. A. & RAAD, R. Year. A transmit power control protocol for multipath wireless sensor networks. *In: Telecommunication Systems Services and Applications (TSSA), 2014 8th International Conference on, 2014. IEEE, 1-5.*
- AL-KARAKI, J. N. & KAMAL, A. E. 2004. Routing techniques in wireless sensor networks: a survey. *Wireless communications, IEEE, 11, 6-28.*
- AL-KARAKI, J. N., UL-MUSTAFA, R. & KAMAL, A. E. Year. Data aggregation in wireless sensor networks-exact and approximate algorithms. *In: High Performance Switching and Routing, 2004. HPSR. 2004 Workshop on, 2004. IEEE, 241-245.*
- BAGULA, A. B. & MAZANDU, K. G. Year. Energy constrained multipath routing in wireless sensor networks. *In: International Conference on Ubiquitous Intelligence and Computing, 2008. Springer, 453-467.*
- BEN-OTHTMAN, J. & YAHYA, B. 2010. Energy efficient and QoS based routing protocol for wireless sensor networks. *Journal of Parallel and Distributed Computing, 70, 849-857.*
- CERPA, A. & ESTRIN, D. 2004. ASCENT: Adaptive self-configuring sensor networks topologies. *IEEE transactions on mobile computing, 3, 272-285.*
- CHATTERJEE, M., DAS, S. K. & TURGUT, D. 2002. WCA: A weighted clustering algorithm for mobile ad hoc networks. *Cluster computing, 5, 193-204.*
- CHEN, Y., CHAN, E. & HAN, S. 2005. Energy efficient multipath routing in large scale sensor networks with multiple sink nodes. *Advanced Parallel Processing Technologies. Springer.*
- CHEN, Y. & NASSER, N. Year. Energy-balancing multipath routing protocol for wireless sensor networks. *In: Proceedings of the 3rd international conference on Quality of service in heterogeneous wired/wireless networks, 2006. ACM, 21.*

- CHOI, H.-H. & LEE, J.-R. 2014. Distributed transmit power control for maximizing end-to-end throughput in wireless multi-hop networks. *Wireless personal communications*, 74, 1033-1044.
- CORREIA, L. H., MACEDO, D. F., DOS SANTOS, A. L., LOUREIRO, A. A. & NOGUEIRA, J. M. S. 2007. Transmission power control techniques for wireless sensor networks. *Computer Networks*, 51, 4765-4779.
- CORREIA, L. H., MACEDO, D. F., SILVA, D. A., DOS SANTOS, A. L., LOUREIRO, A. A. & NOGUEIRA, J. M. S. Year. Transmission power control in MAC protocols for wireless sensor networks. *In: Proceedings of the 8th ACM international symposium on Modeling, analysis and simulation of wireless and mobile systems*, 2005. ACM, 282-289.
- DAS, A. K. & CHAKI, R. 2011. A novel query driven power-balanced routing protocol for WSN. *Int J Wireless Mobile Netw*, 4, 237-248.
- FITZEK, F. H., ANGELINI, D., MAZZINI, G. & ZORZI, M. 2003. Design and performance of an enhanced IEEE 802.11 MAC protocol for multihop coverage extension. *IEEE Wireless communications*, 10, 30-39.
- FONSECA, R., GNAWALI, O., JAMIESON, K. & LEVIS, P. Year. Four-Bit Wireless Link Estimation. *In: HotNets*, 2007.
- FU, B., LI, R., XIAO, X., LIU, C. & YANG, Q. Year. Non-interfering multipath geographic routing for wireless multimedia sensor networks. *In: Multimedia Information Networking and Security*, 2009. MINES'09. International Conference on, 2009. IEEE, 254-258.
- GALLARDO, J. R., GONZALEZ, A., VILLASENOR-GONZALEZ, L. & SANCHEZ, J. Year. Multipath routing using generalized load sharing for wireless sensor networks. *In: Proceeding of the International Conferences on Wireless and Optical Communications*, 2007.
- GANESAN, D., GOVINDAN, R., SHENKER, S. & ESTRIN, D. 2001. Highly-resilient, energy-efficient multipath routing in wireless sensor networks. *ACM SIGMOBILE Mobile Computing and Communications Review*, 5, 11-25.
- GAUTAM, D. R., SHARMA, S. & SAHU, S. 2011. Enhanced transmission power control mechanism based on RSSI for MANET. *International Journal of Computer Applications (0975-8887) Volume*.
- HUANG, T.-H., SANG, T. & YU, Y.-M. Year. An architecture for integrating wireless sensor networks into ip network. *In: Intelligent Computing and Integrated Systems (ICISS)*, 2010 International Conference on, 2010. IEEE, 910-912.

- INTANAGONWIWAT, C., GOVINDAN, R. & ESTRIN, D. Year. Directed diffusion: A scalable and robust communication paradigm for sensor networks. *In: Proceedings of the 6th annual international conference on Mobile computing and networking*, 2000. ACM, 56-67.
- KAMARUDIN, L., AHMAD, R., ONG, B., ZAKARIA, A. & NDZI, D. Year. Modeling and simulation of near-earth wireless sensor networks for agriculture based application using OMNeT++. *In: Computer Applications and Industrial Electronics (ICCAIE), 2010 International Conference on*, 2010. IEEE, 131-136.
- KEY, P., MASSOULIE, L. & TOWSLEY, D. Year. Path selection and multipath congestion control. *In: INFOCOM 2007. 26th IEEE International Conference on Computer Communications*. IEEE, 2007. IEEE, 143-151.
- KIM, K.-H. & SHIN, K. G. 2009. On accurate and asymmetry-aware measurement of link quality in wireless mesh networks. *IEEE/ACM Transactions on Networking (TON)*, 17, 1172-1185.
- KWON, H., KIM, T. H., CHOI, S. & LEE, B. G. 2006. A cross-layer strategy for energy-efficient reliable delivery in wireless sensor networks. *IEEE Transactions on Wireless Communications*, 5.
- LEE, J. & CHUNG, K. 2011. An efficient transmission power control scheme for temperature variation in wireless sensor networks. *Sensors*, 11, 3078-3093.
- LEE, S.-B. & CHOI, Y.-H. 2006. A secure alternate path routing in sensor networks. *Computer Communications*, 30, 153-165.
- LOU, W. & KWON, Y. 2006. H-SPREAD: a hybrid multipath scheme for secure and reliable data collection in wireless sensor networks. *IEEE Transactions on Vehicular Technology*, 55, 1320-1330.
- LOU, W., LIU, W. & ZHANG, Y. 2006. Performance optimization using multipath routing in mobile ad hoc and wireless sensor networks. *Combinatorial optimization in communication networks*. Springer.
- MEGHJI, M. & HABIBI, D. Year. Transmission power control in multihop wireless sensor networks. *In: Ubiquitous and Future Networks (ICUFN), 2011 Third International Conference on*, 2011a. IEEE, 25-30.
- MEGHJI, M. & HABIBI, D. Year. Transmission power control in single-hop and multi-hop wireless sensor networks. *In: International Workshop on Multiple Access Communications*, 2011b. Springer, 130-143.
- MEGHJI, M., HABIBI, D. & AHMAD, I. Year. Performance evaluation of 802.15. 4 medium access control during network association and synchronization for sensor networks. *In:*

- Ubiquitous and Future Networks (ICUFN), 2012 Fourth International Conference on, 2012. IEEE, 27-33.
- MESSIER, G. G., HARTWELL, J. A. & DAVIES, R. J. 2008. A sensor network cross-layer power control algorithm that incorporates multiple-access interference. *IEEE Transactions on Wireless Communications*, 7.
- MING LU, Y. & WS WONG, V. 2007. An energy-efficient multipath routing protocol for wireless sensor networks. *International Journal of Communication Systems*, 20, 747-766.
- MONKS, J. P., EBERT, J.-P., WOLISZ, A. & HWU, W.-M. W. Year. A study of the energy saving and capacity improvement potential of power control in multi-hop wireless networks. *In: Local Computer Networks*, 2001. Proceedings. LCN 2001. 26th Annual IEEE Conference on, 2001. IEEE, 550-559.
- MUELLER, S., TSANG, R. P. & GHOSAL, D. 2004. Multipath routing in mobile ad hoc networks: Issues and challenges. *Performance tools and applications to networked systems*. Springer.
- RADI, M., DEZFOULI, B., BAKAR, K. A. & LEE, M. 2012. Multipath routing in wireless sensor networks: survey and research challenges. *Sensors*, 12, 650-685.
- RADI, M., DEZFOULI, B., RAZAK, S. A. & BAKAR, K. A. Year. LIEMRO: a Low-Interference energy-efficient multipath routing protocol for improving QoS in event-based wireless sensor networks. *In: Sensor Technologies and Applications (SENSORCOMM)*, 2010 Fourth International Conference on, 2010. IEEE, 551-557.
- ROY, S., BANDYOPADHYAY, S., UEDA, T. & HASUIKE, K. Year. Multipath routing in ad hoc wireless networks with omni directional and directional antenna: A comparative study. *In: International Workshop on Distributed Computing*, 2002. Springer, 184-191.
- SAGDUYU, Y. E. & EPHREMIDES, A. 2004. The problem of medium access control in wireless sensor networks. *IEEE Wireless communications*, 11, 44-53.
- SALEEM, K., FISAL, N., HAFIZAH, S., KAMILAH, S. & RASHID, R. 2009. A self-optimized multipath routing protocol for wireless sensor networks. *International Journal of Recent Trends in Engineering*, 2, 93-97.
- SHIN, J., CHIN, M. & KIM, C. Year. Optimal transmission range for topology management in wireless sensor networks. *In: International Conference on Information Networking*, 2006. Springer, 177-185.
- SUBRAMANIAN, A. P. & BUDDHIKOT, M. M. Year. Interference aware routing in multi-radio wireless mesh networks. *In: Wireless Mesh Networks*, 2006. WiMesh 2006. 2nd IEEE Workshop on, 2006. IEEE, 55-63.

- TAM, W.-H. & TSENG, Y.-C. Year. Joint multi-channel link layer and multi-path routing design for wireless mesh networks. *In: INFOCOM 2007. 26th IEEE International Conference on Computer Communications. IEEE, 2007. IEEE, 2081-2089.*
- VIDHYAPRIYA, R. & VANATHI, P. 2007. Energy efficient adaptive multipath routing for wireless sensor networks. *IAENG International Journal of Computer Science, 34, 56-64.*
- VISWANATHAN, H. 2009. *Adaptive transmit power control based on signal strength and frame loss measurements for WLANs.* Rutgers University-Graduate School-New Brunswick.
- WANG, Z., BULUT, E. & SZYMANSKI, B. K. Year. Energy efficient collision aware multipath routing for wireless sensor networks. *In: Communications, 2009. ICC'09. IEEE International Conference on, 2009. IEEE, 1-5.*
- XIU-LI, R., HONG-WEI, L. & YU, W. Year. Multipath routing based on ant colony system in wireless sensor networks. *In: Computer Science and Software Engineering, 2008 International Conference on, 2008. IEEE, 202-205.*
- ZHAO, F. & GUIBAS, L. J. 2004. *Wireless sensor networks: an information processing approach,* Morgan Kaufmann.
- ZHU, J. Year. On the power efficiency and optimal transmission range of wireless sensor nodes. *In: Electro/Information Technology, 2009. eit'09. IEEE International Conference on, 2009. IEEE, 277-281.*