

# **CHAPTER ONE**

# **INTRADUCTION**

# Chapter One: Introduction

## 1.1 Background

In the recent years, with the rapid growth internet business needs, people urgently need more capacity and network systems. So the demand for the transmission capacity and bandwidth are becoming more and more challenging to the carriers and service suppliers. Under this situation, optical fiber is becoming the most favourable delivering media and laying more and more important role in information industry, with its huge bandwidth and excellent transmission performance. Therefore it is necessary to investigate the transmission characteristics of optical fiber. The main goal of any communication system is to increase the transmission distance and capacity [1].

The idea of using dispersion compensation fiber (DCF), for dispersion compensation was proposed in 1980 but, until after the invention of optical amplifiers, DCF began to be widespread attention and study. As the products of DCF are more mature, stable, not easily affected by temperature, wide bandwidth, DCF has become a most suitable method of dispersion compensation. There is positive second-order and third-order dispersion value in Single Mode Fiber (SMF), while the DCF dispersion value is negative. So by inserting a DCF, the average dispersion is close to zero [2].

Dispersion limits the information capacity at high transmission speeds. Dispersion reduces the effective bandwidth and at same time it increases the BER due to an increasing inter symbol interference. In order to remove the spreading of optical pulses, dispersion compensation is required. In single-mode fiber, performance is primarily limited by chromatic dispersion (also called group velocity dispersion) which occurs because the index of the glass

varies slightly depending on the wavelength of the light, and light from real optical transmitters necessarily has nonzero spectral width [3]

Dispersion is severe limiting factors in long distance high data rate transmission system. It is simply the widening of pulse duration as it travels through a fiber. As the optical pulse propagates, it can be considerably broadened to interfere with the neighbouring pulses on the optical fiber communication system, leading to Inter-Symbol Interference (ISI). The dispersion restricts the highest transmission data rate and longest transmission distances for the repeater and reduce the optical communication link. It has been noticed that dispersion of a conventional standard single mode fiber is low . but attenuation is higher at 1310 nm, however it has comparatively high dispersion and minimum attenuation at 1550. To use the previously installed optical fiber cables the main problem related with these optical fiber are that they have high values for chromatic and polarization mode dispersion[4].

Dispersion in single-mode fibers is an intramodal dispersion is a result of group velocity dependence on wavelength. Because of that, the amount of signal distortion depends on the spectral width of the optical source used. Three mechanisms contribute to intramodal dispersion: material dispersion, waveguide dispersion, and polarization-mode dispersion [5].

Material dispersion is caused by variations of refractive index of the fiber material with respect to wavelength. Since the group velocity is a function of the refractive index, the spectral components of any given signal will travel at different speeds causing deformation of the pulse. [6]

Waveguide dispersion occurs because different spectral components of a pulse travel with different velocities by the fundamental mode of the fiber. It is as a result of axial propagation constant  $\beta$  being a function of wavelength due to the existence of one or more boundaries in the structure of the fiber. Without

such boundaries, the fiber reduces to a homogeneous medium, the fundamental mode becomes a uniform plane-wave, and the waveguide dispersion effect is eliminated [7].

Polarization-Mode Dispersion in Single-mode fibers, in reality, support two orthogonally-polarized fundamental modes. In perfectly circular fibers, these two modes have identical propagation constants and pulse spreading due to polarization-mode dispersion does not exist. In practical fibers, however, there is a small difference between the propagation constants of these two modes due to the slight ellipticity of the core. In other words, common single-mode fibers actually support two modes and thus are not truly single-mode. The presence of two fundamental modes contributes to pulse spreading. This phenomenon is known as polarization-mode dispersion [8]

Dispersion compensation schemes are a several techniques can be used to compensate the time dispersion and the chirp effect. To compensate the chirp, a pre compensation scheme, is generally used where the input pulse is changed at the transmitter. There are several pre compensation schemes[9], such as

- ❖ Pre chirp technique.
- ❖ Novel coding technique.
- ❖ Nonlinear pre chirp technique.

## 1.2 Problem statement

When the dispersion occur the pulse of light is spread out during transmission on the fiber. A short pulse becomes longer and ultimately joins with the pulse behind, making recovery of a reliable bit stream impossible. Each pulse broadens and overlaps with its neighbors, eventually becoming indistinguishable at the receiver input.

### **1.3 Proposed solution**

To overcome the problem of dispersion, which is effect the recovery of reliable information in optical fiber component, this thesis proposed the usage of ideal dispersion compensation component.

### **1.4 Aim and objectives**

- The aim of this thesis is to obtain high data rate and wide bandwidth in addition to the following objectives :-
- Develop methodology to simulate the optical fiber system using optisystem simulation tool.
- To reduce dispersion in optical fiber.
- To Increase the speed of data rate in optical fiber.
- To Enhance light signal in optical fiber from transmitter to receiver.

### **1.5 Methodology**

The methodology has been divided to four parts modeling, design, simulation and verification.

- Results and makes sure that the process reducing the dispersion and comparing the Modeling is done by using the mathematical equations of the GVD and Ideal dispersion component.
- The design is done by drawing the figures of component to describe GVD and Ideal dispersion component.
- Simulation is done by analyzing the results from the figures of GVD and the Ideal dispersion component and using optisystem simulation and simulation in dispersion in optical time domain visualizer and optical spectrum analyzer.
- Verification process is done by comparing between the theoretical results and Simulation of Ideal dispersion component.

## 1.6 Thesis Outline

This Dissertation contains five chapters; chapter one is an introduction about the thesis outline; when chapter two included literature review and full details about the major points related to the subject of the thesis; on other hand chapter three contain full description about the circuits design and implementation using the opt system program; then the whole results that obtained by running the circuits which mention at chapter three presented at chapter four with results and discussion and at the last chapter five included the conclusion and recommendation.

**CHAPTER TWO**  
**LITERATURE**  
**REVIEW**

# Chapter Two: Literature Review

## 2.1 Introduction of Fiber Optic Communication System

Optical fiber is a medium for carrying information from one point to another in the form of light. A basic optical fiber system consists of a transmitting device that converts an electrical signal into a light signal, an optical fiber cable that carries the light, and a receiver that accepts the light signal and converts it back into an electrical signal, the system shown in Figure 2-1.

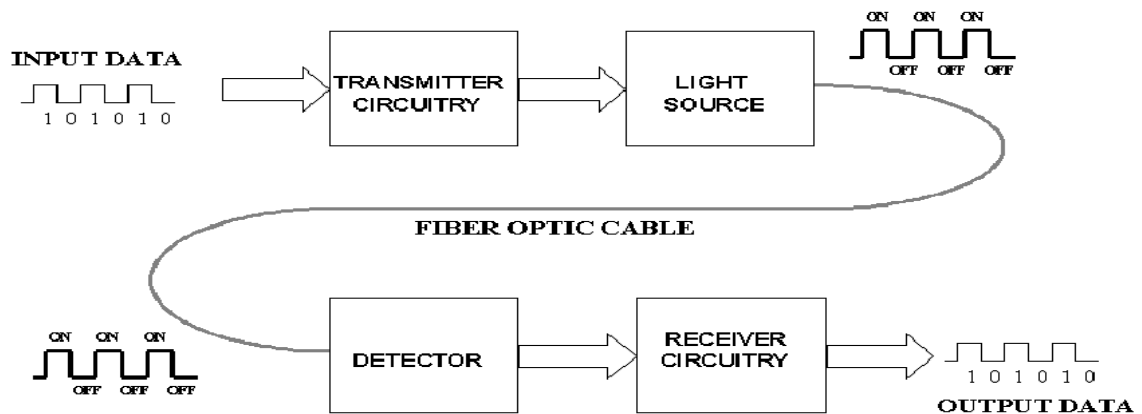

Figure 2-1 Basic fiber optic communication system [1].

## 2.2 Basic Concepts of Fiber Optics

The major Goal of the overall system to communicate information and it can be summarized as flow [2], Transmitter sends signal; each signal has a detected data rate and format and signal modulates a carrier. Signal goes through a length of fiber; during this there is some phenomenon affected the signal and limits the distance like attenuation, dispersion, and noise.

Receiver decodes signal at end; here the most important factors is error rate or signal to noise ratio and the bandwidth defines as bits per second or megahertz/gigahertz; it's increased by increasing data rate and number of



optical in fiber; and limited by fiber dispersion, attenuation, noise, crosstalk, transmitter speed, receiver sensitivity and the range of wavelengths available.

### 2.3 Optical Transmission System Concepts

The basic components of an optical communication system shown in Figure 2.2, below can be summarized as follow [2]. A serial bit stream in electrical form is presented to a modulator, which encodes the data appropriately for fiber transmission. a light source (laser or Light Emitting Diode - LED) is driven by the modulator and the light focused into the fiber. The light travels down the fiber (during which time it may experience dispersion and loss of power). At the receiver end the light is fed to a detector and converted to electrical form. The signal is then amplified and fed to another detector, which isolates the individual state changes and their timing. It then decodes the sequence of state changes and reconstructs the original bit stream (This overview is deliberately simplified. there are many ways to modulate the transmission and the details will vary from this example but the general principle remains unchanged),the timed bit stream received then fed to a device.

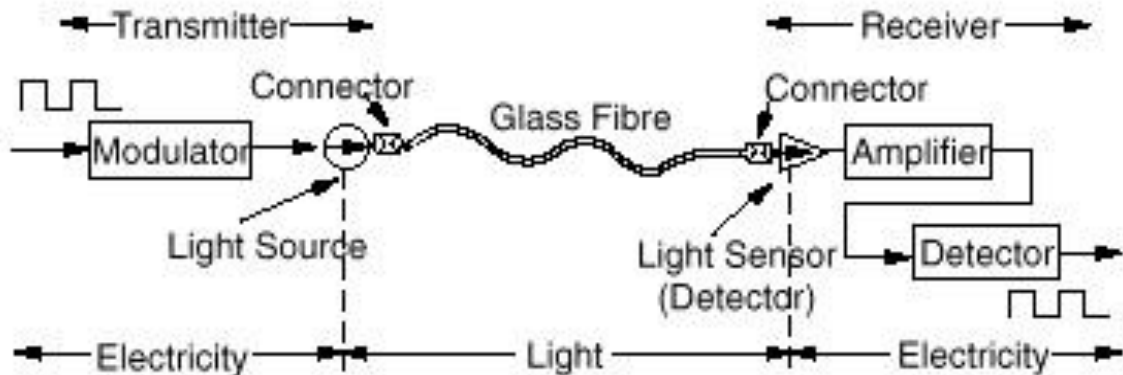

Figure 2.2: Optical Transmission – Schematic. [2]

## 2.4 Transmitting Light on a Fiber

An optical fiber is a very thin strand of silica glass in geometry. In reality it is a very narrow, very long glass cylinder with special characteristics. When the light enters one end of the fiber it travels (confined within the fiber) until it leaves the fiber at the other end. Two critical factors stand out [2], Very little light is lost in its journey along the fiber, Fiber can bend around corners and the light will stay within it and be guided around the corners. An optical fiber consists of two parts as shown in Figure 2.3.

- i. The core; which is a narrow cylindrical strand of glass.
- ii. The cladding; which is tubular jacket surrounding the core.

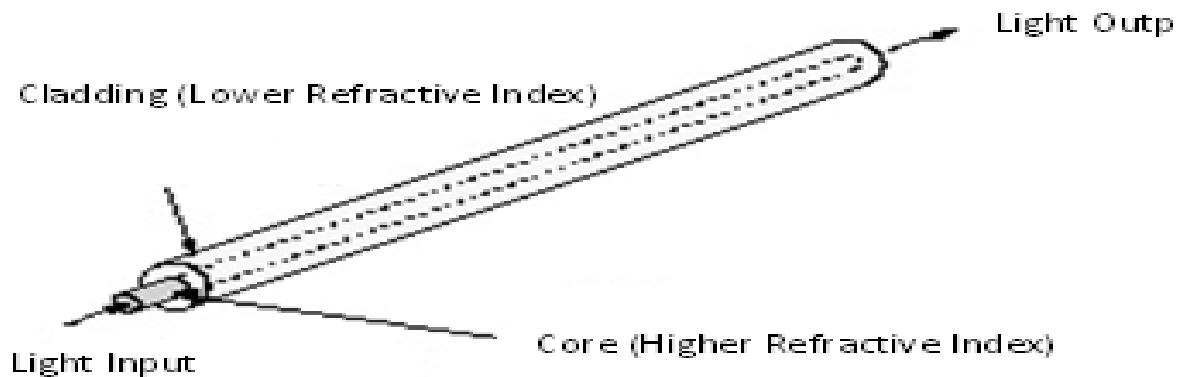

Figure 2.3: Basic Principle of Light Transmission on Optical Fiber [2].

### **2.4.1 Advantages of optical fiber Communication**

One of fiber-optic cables benefits is that it has the highest possible information transmission capacity among all communication cable types with a relatively small cable diameter of typically less than 20 mm (0.8 in.). Other advantages include:

- Long distance transmission due to low attenuation (order of 0.2db/km) thereby reducing number of repeaters (cost & complexity).
- Optical fibers are cheap than the conventional wires.
- Large information capacity due to wider bandwidth.
- Small size & low weight resulting in ease of installation.
- Immunity to electrical interference because of dielectric material.
- Enhanced safety since they do not have ground loops sparks, etc. However, laser light can damage eye.
- Increased signal security since the optical signal is well confined within the fiber.
- Low cost as compared to copper (as glass is made from sand. The raw material used to make of is free).
- Zero resale value (so theft is less).

### **2.4.2 Disadvantages of optical fiber Communication**

Optical transceiver pricing has dropped considerably over the years; this cost can be minimal compared to the overall benefit of optical fiber cable (OFC) deployment. Other drawbacks include:

- OFC is delicate so has to be handled carefully.
- Communication is not totally in optical domain, so repeated electric -optical -electrical conversion is needed and it has relatively finish cost.
- Optical amplifiers, splitters, MUX-DEMUX are still in development stages.

## 2.5 Transmission Windows

Optical fiber transmission uses wavelengths that are in the near-infrared portion of the spectrum, just above the visible, and thus undetectable to the unaided eye. Typical optical transmission wavelengths are 850 nm, 1310 nm, and 1550 nm. Both lasers and LEDs are used to transmit light through optical fiber. Lasers are usually used for 1310- or 1550-nm single-mode applications. LEDs are used for 850- or 1300-nm multimode applications. There are ranges of wavelengths at which the fiber operates best. Each range is known as an operating window. Each window is centered on the typical operational wavelength; these wavelengths were chosen because they best match the transmission properties of available light sources with the transmission qualities of optical fiber as shown in Table 2.1. However, figure 2.4 shows the windows use by optical fiber communication.

Table 2.1: Fiber Optic Transmission Windows

Window	Operating Wavelength
<b>800-900 nm</b>	850 nm
<b>1250 – 1350 nm</b>	1310 nm
<b>1500 – 1600 nm</b>	1550 nm

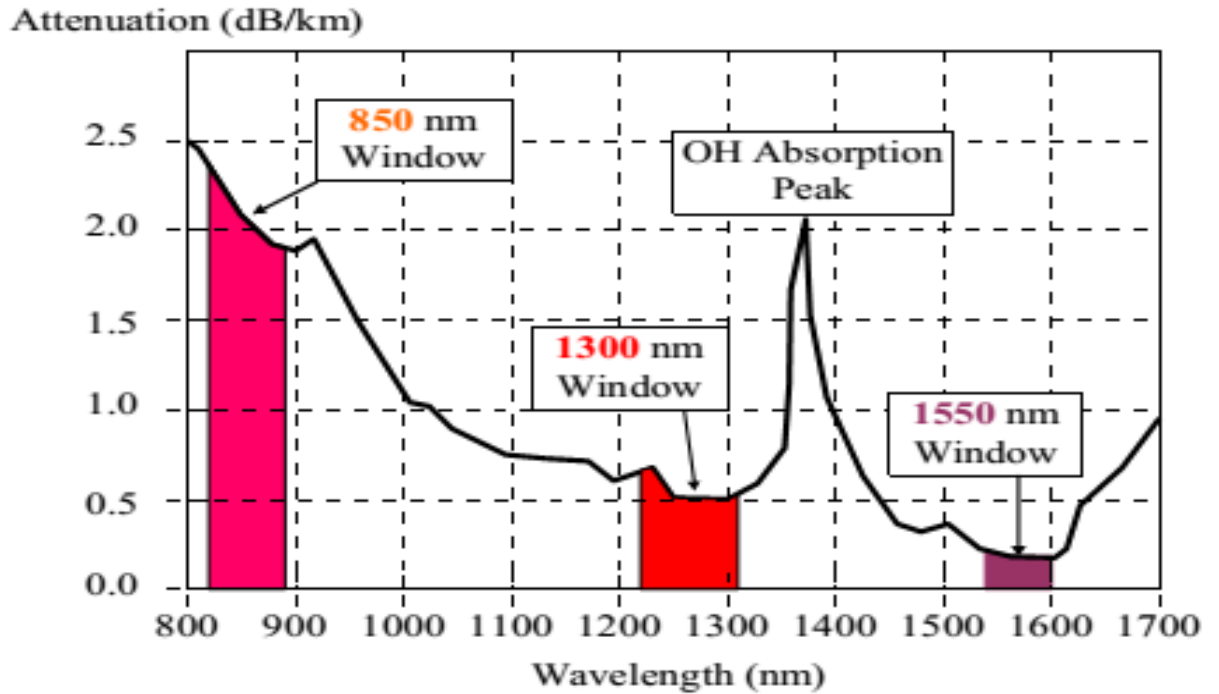

Figure 2-4: Optical fiber windows [23]

### 2.5.1 Wavelength Division Multiplexing

Wavelength Division Multiplexing (WDM) is the basic technology of optical networking. It is a technique for using a fiber (or optical device) to carry many separate and independent optical channels. The principle is identical to that used when we tune our television receiver to one of many TV channels. Each channel is transmitted at a different radio frequency and we select between them using a “tuner” which is just a resonant circuit within the TV set. Of course wavelength in the optical world is just the way we choose to refer to frequency and optical WDM is quite identical to radio FDM. Another way of envisaging WDM is to consider that each channel consists of light of a different color. Thus a WDM system transmits a “rainbow”. Actually at the wavelengths involved the light is invisible but it’s a good way of describing the principle [10]

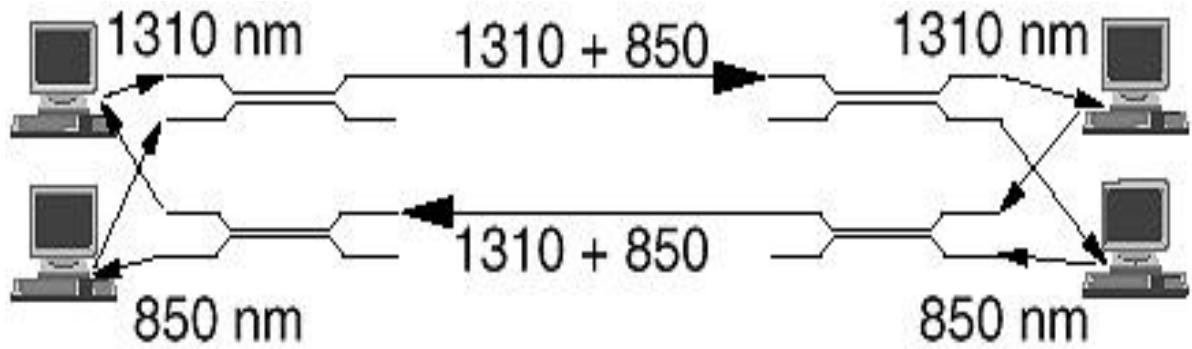

Figure 2.5: Simple (Sparse) WDM [10]

There are many varieties of WDM. A simple form can be constructed using 1310 nm as one wavelength and 1550 as the other or 850 and 1310. This type of WDM can be built using relatively simple and inexpensive components and some applications have been in operation for a number of years using this principle. WDM is the basic technology for full optical networking [20] as shown in figure 2-5.

## 2.6 Chirp Definition

Immediately after power is applied to a laser there is an abrupt change in the carrier (electron and hole) flux density in the cavity caused by the lasing operation itself. This density of charge carriers is one factor that affects the refractive index. In addition, the temperature in the cavity increases quite rapidly. This temperature increase is too localized to affect the length of the cavity immediately but it does contribute to changing the refractive index of the material in the active region (within the cavity). These changes in the RI of the cavity produce a rapid change in the centre wavelength of the signal produced. In the case of semiconductor lasers a “downward” chirp is produced. The wavelength shifts to a longer wavelength than it was

immediately at the start of the pulse. It is not a large problem in short distances single-channel transmissions but in long distance applications and in WDM systems chirp can be a very serious problem. This is due to the fact that it broadens the spectral width of the signal and interacts with other aspects of the transmission system to produce distortion. Indeed, the chirp problem is the main reason that people use external modulators for transmission rates in excess of 1 Gbps [1].

## 2.7 Dispersion

In optics, dispersion is the phenomenon in which the phase velocity of a wave depends on its frequency. Media having this common property may be termed dispersive media. Sometimes the term chromatic dispersion is used for specificity.

### 2.7.1 Dispersion Concept

Pulse spreading with distance is depends on wavelength degrades bandwidth - pulses overlap. The dispersion amount depends on type of fiber, possible of compensation and signal regeneration [1, 2].

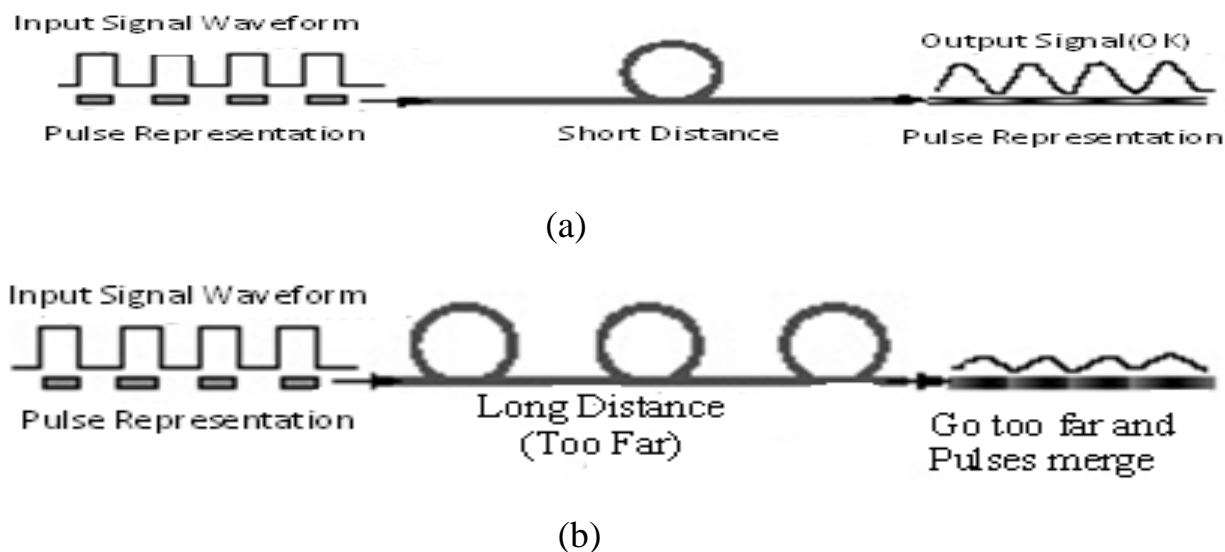

Figure 2.6: Effect of Dispersion, (a) Short Distance. (b) Long Distance [2]

### 2.7.2 Pulse Dispersion:

Pulse dispersion is variety of intersymbol interference (ISI) edify when optical pulses overrun each other in a fiber optic transmission system (FOTS).depends on modal properties of fiber, determined by fiber type & composition and degree of dispersion depends on fiber type. The optical pulse widening of an it travels the length of a fiber. This particularity limits the beneficial of bandwidth of the fiber is usually expressed in terms of nanoseconds of widening per kilometer. In figure 2.7 we demonstrate the pulse dispersion in 2.7a Initial Instantaneous Pulses; in 2.7b Successive pulses, in 2.7c Spreading increases with distance, in 2.7d Unintelligible.

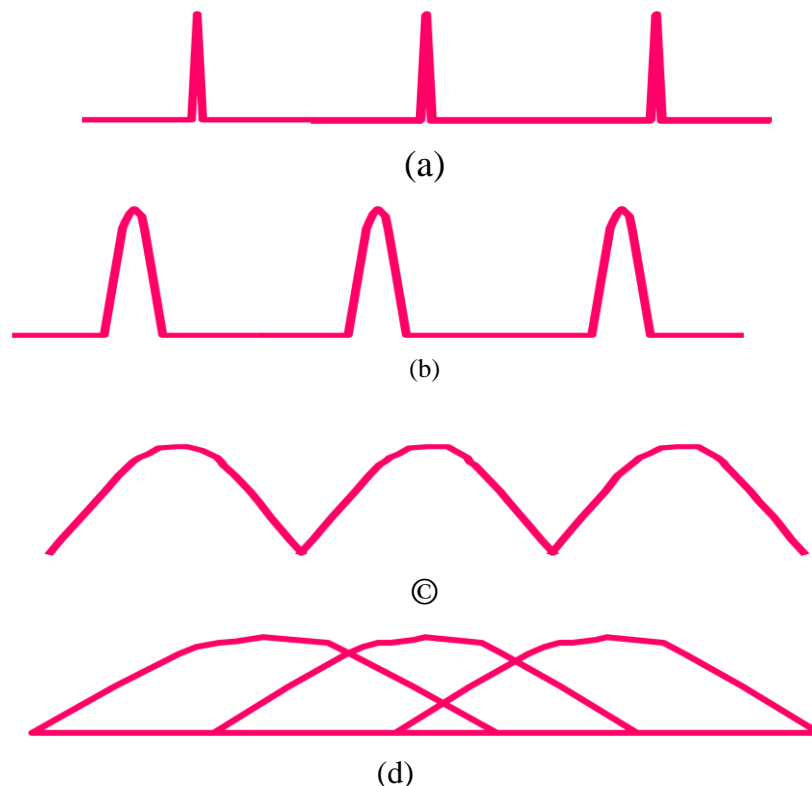

Figure 2.7: Pulse Dispersion Initial Instantaneous Pulses, (a) Successive pulses (b) Spreading increases with distance (c) Unintelligible (d) Unintelligible [8]



### **2.7.3 Dispersion Mechanism**

Dispersion occurs when a pulse of light is spread out during transmission on the fiber. A short pulse becomes longer and ultimately joins with the pulse behind, making recovery of a reliable bit stream impossible. (In most communications systems bits of information are sent as pulses of light. 1 = light, 0 = dark. But even in analog transmission systems where information is sent as a continuous series of changes in the signal, dispersion causes distortion.)[1, 2].

### **2.8 Effect of Dispersion**

Dispersion of transmitted optical signal causes distortion for both digital and analog transmission along optical fiber. When considering the major implementation of optical fiber transmission which involves some form of digital modulation, the dispersion mechanism within the fiber cause broadening of transmitted light pulses as they travel along the channel. It may be observed from the Figure (2.8) that each pulse broadens and overlaps with its neighbors, eventually becoming indistinguishable at the receiver input. The effect is known as inter symbol interference (ISI);thus an increasing number of errors may be encountered on the digital optical channel as the ISI becomes more pronounced [2].Figure 2.8 an illustration of the broadening of light pulses as they are transmitted along a fiber using the digital bit pattern 1011[23].

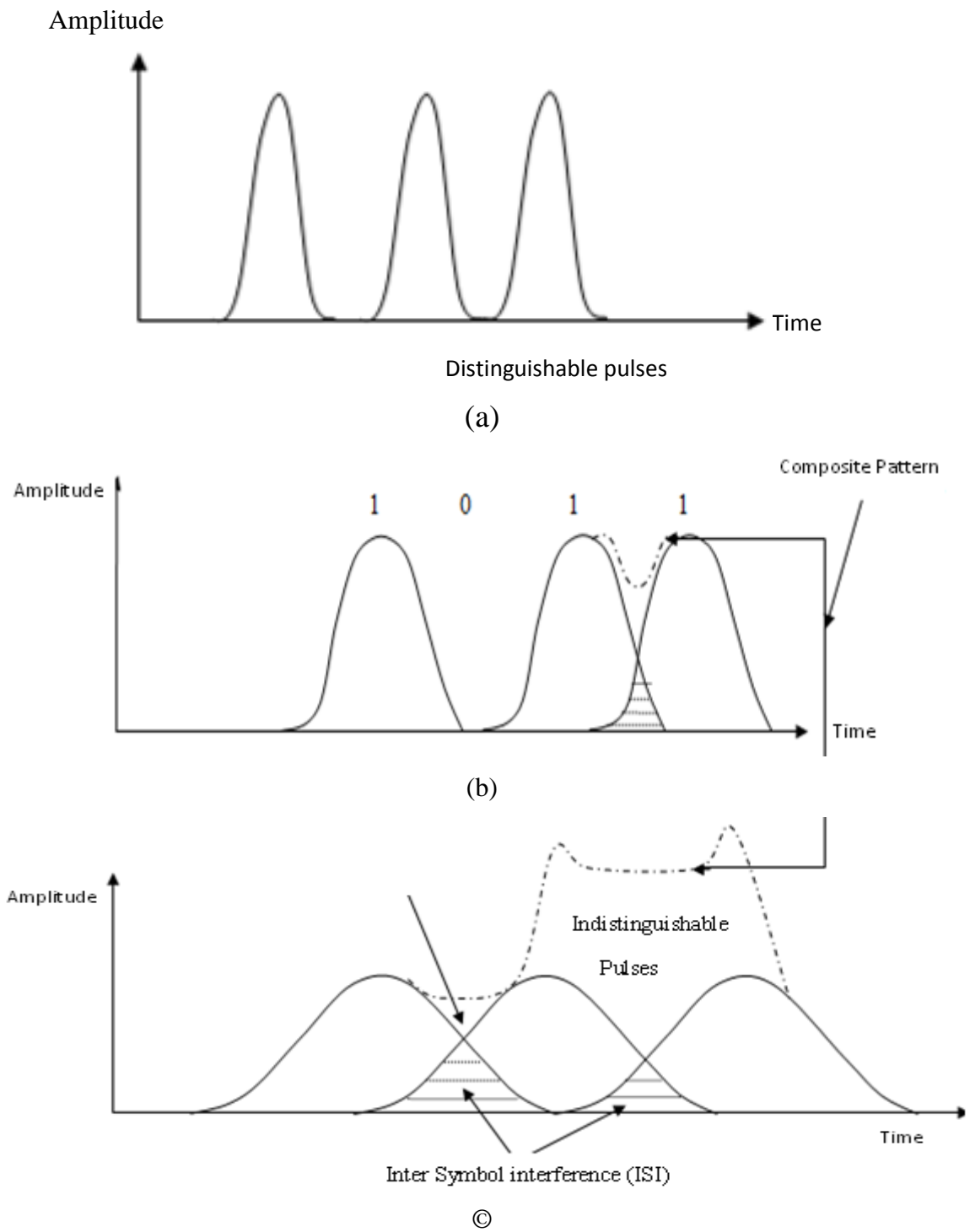

Figure 2.8: Broadening of Light Pulses,(a)Fiber Input(b) Fiber Output at a Distance  $L_1$   
(c) Fiber Output at a Distances  $L_2 > L_1$ [23].

There are many kinds of dispersion, each of which works in a different way, but the most important three are discussed below [3].

- i. Material dispersion (chromatic dispersion); (ps/nm bandwidth, fiber/km); increases with source bandwidth; both lasers and LEDs produce a range of optical wavelengths (a band of light) rather than a single narrow wavelength. The fiber has different refractive index characteristics at different wavelengths and therefore each wavelength will travel at a different speed in the fiber. Thus, some wavelengths arrive before others and a signal pulse disperses (or spreads out).
- ii. Modal dispersion (nanoseconds/fiber km); largest and depends on number of modes; when using multimode fiber (doesn't occur at single mode fiber), the light is able to take many different paths or "modes" as it travels within the fiber. The distance traveled by light in each mode is different from the distance travelled in other modes. When a pulse is sent, parts of that pulse (rays or quanta) take many different modes (usually all available modes). Therefore, some components of the pulse will arrive before others. The difference between the arrival times of light taking the fastest mode versus the slowest obviously gets greater as the distance gets greater.
- iii. Waveguide dispersion (ps/nm bandwidth, fiber km); is a very complex effect and is caused by the shape and index profile of the fiber core. However, this can be controlled by careful design and, in fact; waveguide dispersion can be used to counteract material dispersion as will be seen later.

## 2.9 Single-Mode Fiber

In optical fiber technology, single mode fiber is optical fiber that is designed for the transmission of a single ray or mode of light as a carrier and is used for long-distance signal transmission.

### 2.9.1 Features of Single-Mode Fiber

When the fiber core is very narrow compared to the wavelength of the light in use then the light cannot travel in different modes and thus the fiber is called “single-mode” or “monomode” it show in figure 2.9. There is no longer any reflection from the core-cladding boundary but rather the electromagnetic wave is tightly held to travel down the axis of the fiber. It seems obvious that the longer the wavelength of light in use, the larger the diameter of fiber we can use and still have light travel in a single-mode. The core diameter used in a typical single-mode fiber is nine microns. It is not quite as simple as this in practice. A significant proportion (up to 20%) of the light in a single-mode fiber actually travels in the cladding. For this reason the “apparent diameter” of the core (the region in which most of the light travels) is somewhat wider than the core itself. The region in which light travels in a single-mode fiber is often called the “mode field” and the mode field diameter is quoted instead of the core diameter. The mode field varies in diameter depending on the relative refractive indices of core and cladding, Core diameter is a compromise. We can't make the core too narrow because of losses at bends in the fiber. As the core diameter decreases compared to the wavelength (the core gets narrower or the wavelength gets longer), the minimum radius that we can bend the fiber without loss increases. If a bend is too sharp, the light just comes out of the core into the outer parts of the cladding and is lost. The more important issue to make fiber single-mode is:

- i. Making the core thin enough.

- ii. Making the refractive index difference between core and cladding small enough.
- iii. Using a longer wavelength.

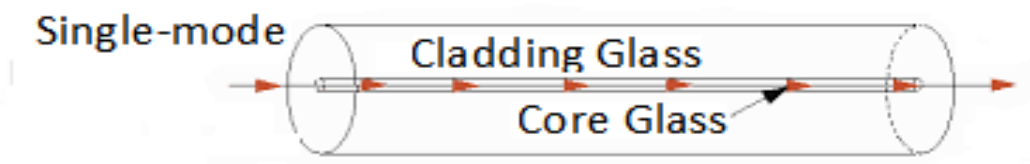

Figure 2.9: Single-Mode Fiber [2]

This figure is not to scale. The core diameter is typically between 8 and 9 microns while the diameter of the cladding is 125 microns. Single-mode fiber usually has significantly lower attenuation than multimode (about- half). Single-mode fibers have a significantly smaller difference in refractive index between core and cladding. The most important feature for the single mode fiber is [3].

- i. Single-mode transmission is simple.
- ii. No modal dispersion.
- iii. No modal noise.
- iv. Transmission distance limited by chromatic dispersion.
- v. Several types available differ in dispersion properties.

It's not strictly correct to talk about "single-mode fiber" and "multimode fiber" without qualifying it - although we do this all the time. A fiber is single-mode or multi-mode at a particular wavelength. If we use very long wave light (say 10.6 nm from a CO<sub>2</sub> laser) then even most MM fiber would be single-mode for that wavelength. If we use 600 nm light on standard single-mode fiber then we do have a greater number of modes than just one (although

typically only about 3 to 5). There is a single-mode fiber characteristic called the “cutoff wavelength”. This is typically around 1100 nm for single-mode fiber with a core diameter of 9 microns. The cutoff wavelength is the shortest wavelength at which the fiber remains single-mode. At wavelengths shorter than the cutoff the fiber is multimode. When light is introduced to the end of a fiber there is a critical angle of acceptance. Light entering at a greater angle passes into the cladding and is lost. At a smaller angle the light travels down the fiber. If this is considered in three dimensions, a cone is formed around the end of the fiber within which all rays are contained. The sine of this angle is called the “numerical aperture” and is one of the important characteristics of a given fiber. Single-mode fiber has a core diameter of 4 to 10  $\mu\text{m}$  (8  $\mu\text{m}$  is typical). Multimode fiber can have many core diameters but in the last few years the core diameter of 62.5  $\mu\text{m}$  in the US and 50  $\mu\text{m}$  outside the US has become predominant.

### **2.9.2 Types of Single-Mode Fiber**

There are two type of single mode fiber which is:

#### 1. Step-Index single-mode fiber (simple) [2]

Matched cladding, Cladding can be depressed by reduces core doping and dopes cladding to reduce index.

#### 2. Dispersion-shifted fiber [2]

More complex core-cladding design, larger waveguide dispersion, Shifts zero chromatic dispersion, higher dispersion slope and Minimum dispersion needed to prevent four-wave mixing.

And it has the following characteristics of single-mode fiber (Standard Fiber) were specified by the International Telecommunications Union (ITU) in the 1980's. The key specifications are as follows [1, 2].

- i. Cladding diameter = 125 microns.

- ii. Mode field diameter = 9-10 microns at 1300 nm wavelength.
- iii. Cutoff wavelength = 1100-1280 nm.
- iv. Bend loss (at 1550 nm) must be less than 1 dB for travel through 100 turns of fiber wound on a spool of 7.5 cm diameter.
- v. Dispersion in the 1300 nm band (1285-1330 nm) must be less than 3.5 ps/nm/km. At wavelengths around 1550 nm dispersion should be less than 20ps/nm/km. (Picoseconds of dispersion per nanometer of signal bandwidth per kilometer of distance travelled).
- vi. The rate of change of dispersion with wavelength must be less than .095ps/nm<sup>2</sup>/km. This is called the dispersion slope.

## 2.10 Dispersion in Single-Mode Fiber

Since modal dispersion cannot occur in single-mode fiber (as only have one mode), the major sources of dispersion are chromatic dispersion (waveguide and material dispersion) and group velocity dispersion [20].

### 2.10.1 Chromatic Dispersion

Chromatic Dispersion is about the difference in speed between the various wavelengths contained in a light pulse, each light pulse consists of many wavelengths, each wavelength travels on its own speed down the fiber, thus it reaches the destination in a different time than other wavelengths, which results in the pulse broadening phenomena, that's defined by three parameters, the first delay for a specific wavelength expressed in ps , second is The dispersion coefficient (D) expressed in ps/nm, it corresponds to the change in delay as a function of wavelength, and it can be expressed as ps/(nm.km) if normalized to one kilometer and the last parameters is the slope (S) ps/((nm<sup>2</sup>).km), this refers to the change in the dispersion coefficient as a function of wavelength. It depends mainly on the manufacturing process, so it

does not normally change by time, by installation process, or by environmental changes, that's not the case when compared to Polarization Mode Dispersion (PMD). The figure below showing different wavelengths in a light source:

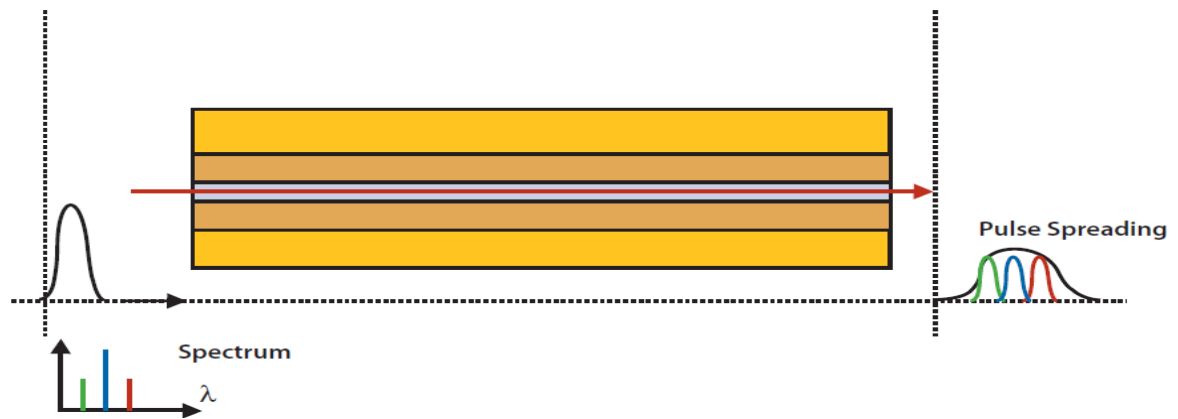

Figure 2.10: chromatic dispersion [20].

### 2.10.2 Material Dispersion

This is caused by the fact that the refractive index of the glass we are using varies (slightly) with the wavelength. Some wavelengths therefore have higher group velocities and so travel faster than others. Since every pulse consists of a range of wavelengths it will spread out to some degree during its travel [2].

### 2.10.3 Waveguide Dispersion

The shape (profile) of the fiber has a very significant effect on the group velocity. This is because the electric and magnetic fields that constitute the pulse of light extend outside of the core into the cladding. The amount that the fields overlap between core and cladding depends strongly on the wavelength. The longer the wavelength the further the electromagnetic wave extends into the cladding. The RI experienced by the wave is an average of the RI of core



and cladding depending on the relative proportion of the wave that travels there. Thus since a greater proportion of the wave at shorter wavelengths is confined within the core, the shorter wavelengths a higher RI than do longer wavelengths. (Because RI of the core higher than the cladding). Therefore shorter wavelengths tend to travel more slowly than longer ones. Thus signals are dispersed (because every signal consists of a range of wavelengths) [2].

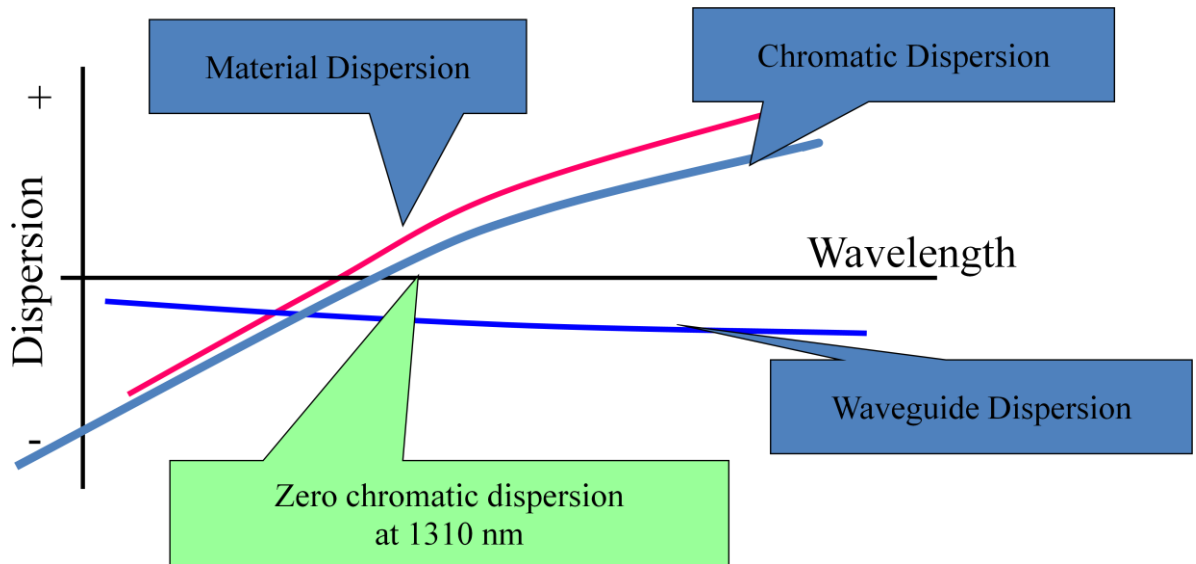

Figure 2.11 Step-Index Single-Mode Dispersion [9]

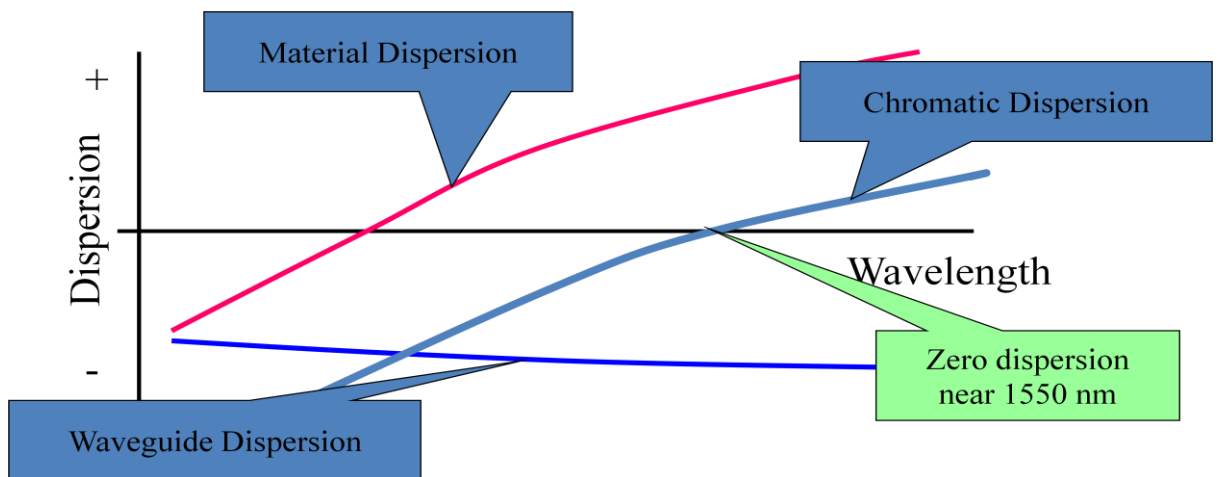

Figure 2.12: Dispersion-Shifted Single-Mode [9].

Dispersion (from all causes) is often grouped under the name “Group Velocity Dispersion” (GVD).

## **2.11 Group Velocity Dispersion**

The group velocity of a wave is the velocity with which the overall shape of the wave's amplitudes known as the modulation or envelope of the wave propagates through space. For transmission system operation the most important & useful type of velocity is the group velocity, this is the actual velocity which the signal information & energy is traveling down the fiber. It is always less than the speed of light in the medium. Group velocity is the usual way of discussing the speed of propagation on a fiber. It is the speed of propagation of modulations along the fiber. It is generally a little less than the phase velocity. The reason that group velocity is different from phase velocity is related to the amount of dispersion of the medium. If there is no dispersion in the medium then group velocity and phase velocity are the same. The group velocity associated with the fundamental mode is frequency dependent because of chromatic dispersion. As a result, different spectral components of the pulse travel at slightly different group velocities, a phenomenon referred to as group-velocity dispersion (GVD), intermodal dispersion, or simply fiber dispersion. Intermodal dispersion has two contributions, material dispersion and waveguide dispersion. We consider both of them and discuss how GVD limits the performance of light wave systems employing single-mode fibers.

On standard single-mode fiber we consider two GVD regimes [11].

- i. The normal dispersion regimes represented in Figure 2.10 at the left of the point where the line crosses the zero dispersion point. In this region the long wavelengths travel faster than the short ones! Thus after travelling on

fiber wavelengths at the red end of the pulse spectrum will arrive first. This is called a positive chirp.

**Note:** The use of the terms “red end” and “blue end” here requires some explanation. Any wavelength longer than about 700 nm is either visible red or infra-red. Thus all of the wavelengths in question can be considered “red”. However, it is very useful to identify the shorter wavelength (higher frequency) end of a pulse spectrum as the “blue end” and the longer wavelength (lower frequency) end as the “red end”.

ii. Anomalous dispersion regime this is represented by the section of the figure to the right of the zero crossing point. Here, the short wavelengths (blue end of the spectrum) travel faster than the long wavelengths (red end). After travel on a fiber the shorter wavelengths will arrive first. This is considered a negative chirp.

**Note:** The definitions of the words “normal” and “anomalous” given above are consistent with those used in most textbooks and in the professional literature. In some engineering contexts the use of the terms is reversed. That is, what we have defined above as normal becomes anomalous and what we defined as anomalous is called normal [22].

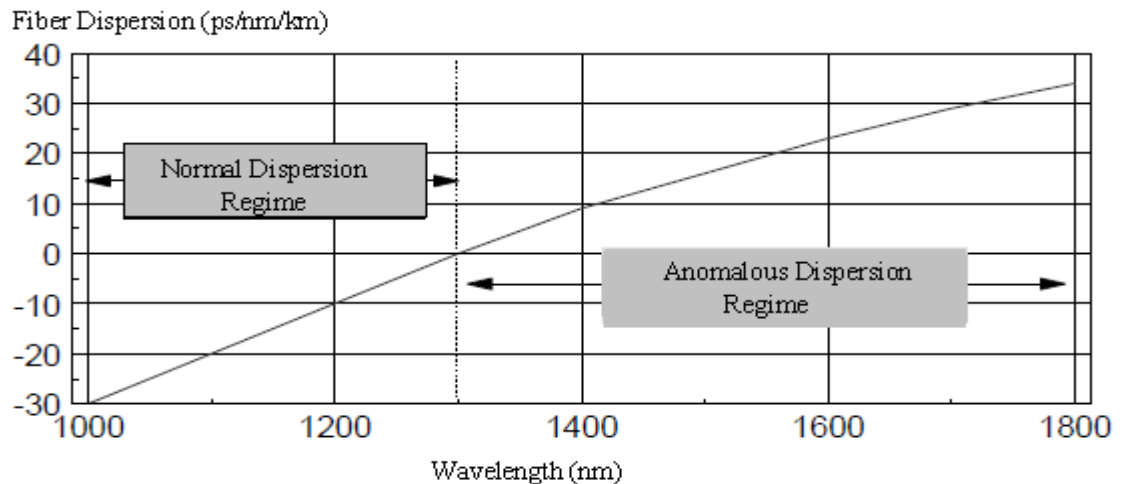

Figure 2.13: Dispersion of “Standard” Single-Mode Fiber [22].

It seems obvious that the wider the spectral width of our signal the more dispersion we will have. Conversely, the narrower signal is less dispersion. In SM fiber dispersion usually quoted in picoseconds of dispersion per nanometer of spectral width per kilometer of propagation distance (ps/nm/km) [20].

## **2.12 Control of Dispersion in Single-Mode Fiber Links**

Dispersion broadens a pulse by an amount unrelated to the length of the pulse. Dispersion becomes a problem for a receiver when it exceeds about 20% of the pulse length. Thus, if a pulse at 200 Mbps is dispersed on a given link by 15% then the system will probably work. If the data rate is doubled to 400 Mbps the dispersion will be 30% and the system will probably not work. Hence the higher data rate, the more important the control of dispersion becomes [20].

- i. Modal dispersion does not exist in single-mode fiber. There is however, a trivial form of modal dispersion caused by birefringent effects spreading the two orthogonal polarization modes in a “single” mode fiber. This is called Polarization mode dispersion. However, the effect is usually trivial. In very short single-mode links (less than a few hundred meters) you can get modal dispersion due to additional modes being carried in the cladding. These disappear after a relatively short distance but they can be excited at the laser coupling or in a bad coupler or join.
- ii. Material dispersion is significant in both types of fiber.
- iii. Waveguide dispersion is significant in both MM and SM fibers but dominates in the SM case because there is no modal dispersion here. Both material and waveguide dispersion are wavelength dependent effects. If we had a zero spectral width there would be no problem with these types of

dispersion. Waveguide dispersion can be manipulated so that it acts in the opposite direction (has the opposite sign) to material dispersion. Single-mode fibers (for wide-area applications) of the late 1980s were adjusted such that the two forms of dispersion cancelled each other out at a wavelength of 1310 nm. For this reason, the 1300 nm band was widely used for long distance communication links at that time. However, the attenuation in the 1300 nm band is almost twice that of attenuation in the 1500 nm band. Worse, EDFAs (Erbium Doped Fiber Amplifiers) only work in the 1500 nm band, so if we want to use amplifiers, then we must use 1500 nm. Many things can do to the fiber to reduce waveguide dispersion (such as varying the refractive index of core and cladding and changing the geometry of the fiber) and it is now possible to balance the two forms of dispersion at 1500 nm. This type of fiber is called “Dispersion Shifted Fiber”. Another way of minimizing dispersion (both material and waveguide) is to use a narrow spectral width laser. These techniques combined have meant that almost all new long distance single-mode systems are being installed at 1500 nm [2, 3].

- **Dispersion Calculating**

Waveguide dispersion is usually quoted in (ps per nm per km) at a given wavelength. At 1500 nm a typical dispersion figure is 17ps/nm/km. That is, a pulse (regardless of its length) will disperse by 17 picoseconds per nanometer of spectral width per kilometer of distance travelled in the fiber. So, in a typical single-mode fiber using a laser with a spectral width of 6 nm over a distance of 10 km we have.

$$\text{Dispersion} = 17\text{ps/nm/km} \times 6\text{nm} \times 10\text{km} = 1020\text{ps}$$

At 1 Gbps a pulse is 1 ns long. When data has been sent over the above link at 1 Gbps then the result of dispersion would be 102%, so the system would not work (20% is a good guideline for the acceptable limit). But it would probably

work quite well at a data rate of 155 Mbps (a pulse length of 6.5 ns). A narrow spectral width laser might produce only one line with a line width of 300 MHz. Modulating it at 1 Gbps will add 2 GHz. 2,300 MHz is just less than .02 nm (at 1500 nm); that give [2] .

$$\text{Dispersion} = 17\text{ps/nm/km} \times .02\text{nm} \times 10\text{km} = 3.4\text{ps}$$

So in this point, dispersion just ceased to be a problem.

- **Control of Spectral Width**

Perhaps the most obvious thing we can do about dispersion is to control the spectral width of the signal! Chromatic dispersion is a linear function of spectral width. If you double the spectral width you double the dispersion. An important factor is that modulation adds to the bandwidth of the signal! The modulation broadens the signal by twice the highest frequency present in the modulating signal. Modulation with a square wave implies the presence of significant harmonics up to 5 times the fundamental frequency of the square wave! (Indeed a perfect square wave theoretically contains infinity of higher frequency components.); as example, if we want to modulate at 1 Gbps then the fundamental frequency is 500 MHz. A significant harmonic at 2.5 GHz will be present and therefore the broadening of the signal will be 5 GHz or about .04 nm. If we want to modulate at 10 GHz then signal broadening will be perhaps .4 nm. It is easily seen that these amounts are not significant if the laser spectral width is 5 nm but critically significant if the spectral width is .01 nm! This can be controlled by filtering the square wave modulating signal to remove higher frequency harmonics. But this filtering reduces the quality of the signal at the receiver.

In practical systems we don't worry about the 5th harmonic and usually can be content with the 3rd. So if we filter a 1 Gbps signal at about 1.5 GHz (at the transmitter) then we can usually build a receiver to suit [13].

- **Dispersion Shifted Fiber**

Is designed with dispersion zero point at around 1550 nm. For operation in the 1550 nm band this should be ideal. However, it is not always possible or indeed desirable.

- i. In many cases we can't have DSF because the fiber we must use is already installed. Digging up a few hundred kilometers of roadway to replace fiber types is an extremely costly exercise.
- ii. If we are using (or planning to use) WDM technology the problems of four-wave mixing effectively prohibit the use of DSF.
- iii. If we have a very long amplified link with many cascaded amplifiers we have another problem. The amplifiers will generate a certain amount of amplified spontaneous emission (ASE) noise at wavelengths near to the signal. While this ASE can be filtered out at the receiver it will usually be present on the link. Any ASE within about 2 nm in wavelength of the signal will undergo four wave mixing (FWM) with the signal and create significant noise! Of course we could filter it out at the output stage of each amplifier but that would mean a long series of cascaded filters which would narrow the signal itself.

Except in the case of a limited number of amplifier spans DSF is not a good solution to the dispersion problem [11].

- **Dispersion Compensating Fiber**

For "Dispersion in Single-Mode Fiber" the core profile of a fiber can be controlled to produce just the amount of dispersion we want. In order to equalize an installed link with dispersion at 1550 nm of 17ps/nm/km (standard fiber) we can connect a (shorter) length of compensating fiber in series with it. The compensating fiber typically has a dispersion of -100ps/nm/km in the 1550 nm wavelength band. Because the dispersion acts in the opposite direction to

the dispersion of the standard fiber the compensating fiber “undisperses” the signal. You might compensate a 100 km length of standard fiber for operation at 1550 nm by connecting it to 17 km of shifted fiber show in figure 2-11. However, almost by definition you are not installing the fiber new. So the added length of fiber sits at one end of the link on a drum. This adds to attenuation and additional amplification may be needed to compensate for the compensating fiber! DCF has a typical attenuation of .5dB/km. In addition the narrow core of DCF makes it more susceptible to non-linear high power effects than standard fiber and it is also polarization sensitive [21].

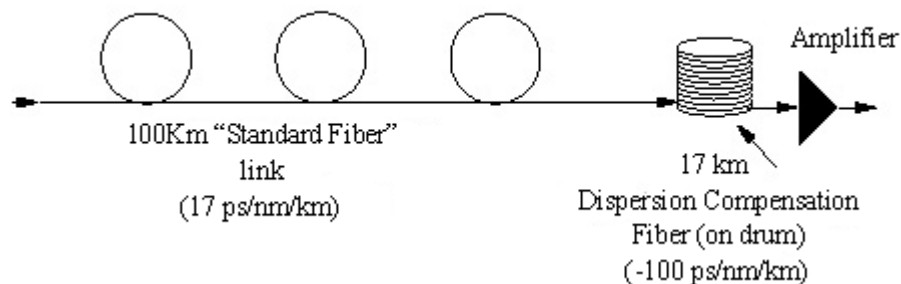

Figure 2.14: Dispersion Compensation of an Existing Standard Fiber Link [21].

The Faraday rotating mirror is used to rotate the polarization of the reflected signal. Thus any PMD is transit the same section of DCF again with rotated polarization, In addition the transit in an opposite direction. When installing a new optical fiber link there is a ability to plan for dispersion and the necessary compensation.

Figure 2:14 shows a link configuration with “lumped” dispersion compensation at the mid-span point of the link. In this case you only need half the length of DCF that you might need otherwise (because the light transits the DCF twice). The lumped DCF compensates for dispersion over the whole length of the link. This configuration has the advantage that you can use a



Faraday rotating mirror to rotate the polarization of the signal. Thus any unwanted polarization dependencies introduced in the DCF are undone by the fact that the light has to transit the same section of DCF again with rotated polarization. In addition, unwanted polarization dependencies in the long link itself can be offset somewhat (to the extent that they are the same over the two halves of the link). Indeed this last point is the reason for sitting the DCF at mid-span. The major problem with this configuration is that you need access to the link at mid-span. This may not be easily possible in an installed link [19].

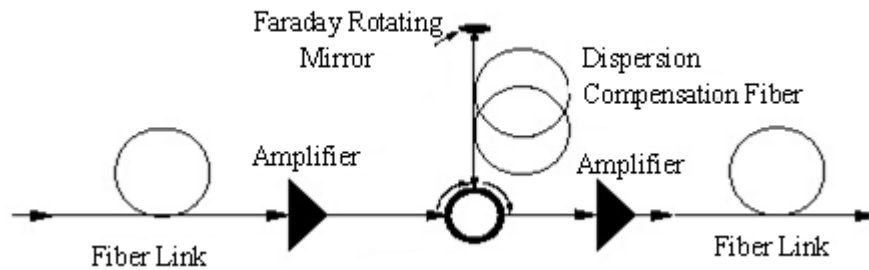

Figure 2.15: Dispersion Compensation Using a Mid-Span DCF [19].

- **Balancing Dispersion on a Link**

Of course, if we are planning to operate in the 1550 nm band we could install Dispersion Shifted Fiber (DSF). This has a dispersion of zero at 1550 nm. However, as mentioned before, WDM systems have a severe problem if the fiber dispersion is really zero! This problem is called 4-wave mixing “Four-Wave Mixing (FWM)”. It turns out that for WDM operation needed some dispersion to minimize 4-wave mixing. Fiber with a dispersion of 4ps/nm/km can be used to mitigate FWM but in very long amplified links (such as many undersea cables) even this minimal level of dispersion is a limitation. In this case the system architects sometimes employ a balanced structure where sections of dispersive fiber with different dispersion characteristics are joined to form the span. The idea here is that no section of fiber has zero dispersion

but that different sections have dispersion of opposite sign so that the total at the end of the link (span) is zero.

In new link designers tend not to use such strongly dispersive fibers and instead might use a fiber with a dispersion of  $-2\text{ps/nm/km}$  for the majority of the link. To compensate for this at intervals they insert a section (or sections) of standard ( $17\text{ ps/nm/km}$ ) fiber in the link. There are a number of very long undersea links currently in operation which use this dispersion management technique. An undersea link with four WDM channels each operating at 2.4 Gbps over a distance of 4000 km has been reported as an operational system [20] to show in figure 2.15.

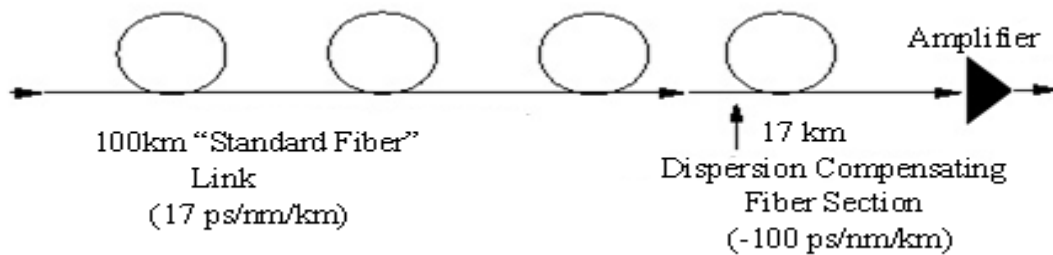

Figure 2.16: Dispersion Compensation of a New Link with DCF [20].

**Note:** In a WDM system it is quite hard to balance dispersive properties of fibers in this way. This is because the range over which the WDM signals are spread may be of the order of 30 or 40 nm. The dispersion characteristics of each fiber used will be different at different points over the wavelength range. Matching dispersion characteristics over a range of wavelengths can be very difficult. This may well result in one channel of the WDM spectrum having zero dispersion (total at the end of the link) and other channels having significant finite dispersion [2].

- **Mid-Span Spectral Inversion**

The concept here is to use a device in the middle of the link to invert the spectrum. This process changes the short wavelengths to long ones and the long wavelengths to short ones. If you invert the spectrum in the middle of a link (using standard fiber) the second half of the link acts in the opposite direction (really the same direction but the input has been exactly pre-emphasized). When the pulse arrives it has been re-built exactly - compensated for by the second half of the fiber. Mid-span spectral inversion is a bit difficult to implement in all situations because you have to put an active device into the middle of the fiber link. This may or may not be practical (you might not be able to get access to the mid-point of the fiber link) [2] to show in figure 2.16.

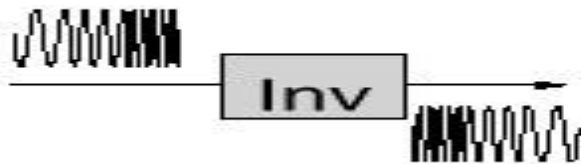

Figure 2.17: Spectral Inverter – Schematic Dispersion [2].

Figure 2.17 show a dispersed pulse before input to a phase conjugation process and then at output. The wavelength spectrum has been completely inverted. This spectral inversion is performed by a process called “optical phase conjugation”. Devices that change the wavelength using either four -Wave Mixing or Difference Frequency Generation invert the spectrum as a byproduct of their wavelength conversion function. These can be used as spectral inverters if we can tolerate the wavelength shift involved. Although there are devices that can perform phase conjugation (the spectral inversion function) in reality what is often used here is just a section of dispersion compensating fiber on a drum.

Several kilometers are typically used. So this can reduce to just another configuration option of dispersion compensating fiber [2].

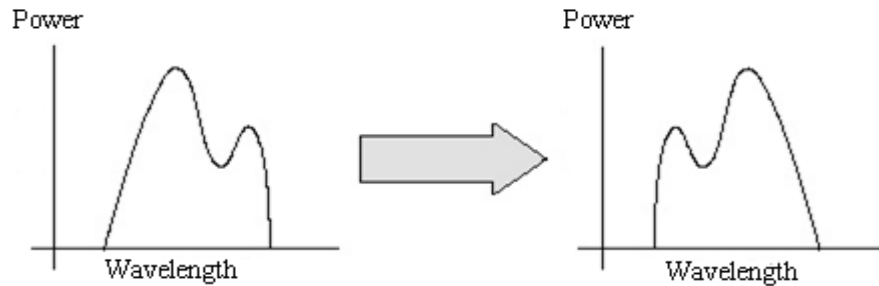

Figure 2.18: Spectral Inversion - Wavelength (Frequency) Domain [2].

- **Chirped Fiber Bragg Gratings**

FBGs are perhaps the most promising technology for dispersion compensation. A “chirped” FBG is used where the spacing’s of the lines on the grating vary continuously over a small range. Shorter wavelength light entering the grating travels along it almost to the end before being reflected. Longer wavelength light is reflected close to the start of the grating. Thus short wavelengths are delayed in relation to longer ones. Since the pulse has been dispersed such that short wavelengths arrive before the long ones, the grating can restore the original pulse shape. It undoes the effects of dispersion. The configuration requires a circulator to direct the light in and out of the grating as shown in Figure 2.18. Chirped FBGs need to be quite long (for a simple single-channel application up to 20 cm is commonly required). In a WDM system a fully continuous chirp would require a very long grating indeed. To compensate for 100 km of standard (17 ps/nm/km) fiber the chirped grating needs to be 17 cm long for every nm of signal bandwidth! In this instance a WDM system with channels spread over (say) 20 nm would need a chirped FBG (20 × 17) 340 cm long! Long FBGs are very hard to construct! The current technological limit is

about 1 meter in length. In a single-channel application you build the grating as a concatenated series of fixed wavelength gratings rather than as a continuous variable grating. This means you don't need to maintain phase continuity between the different sections. You can write the grating in a number of separate operations and of course this means that it can be as long as you like [12]

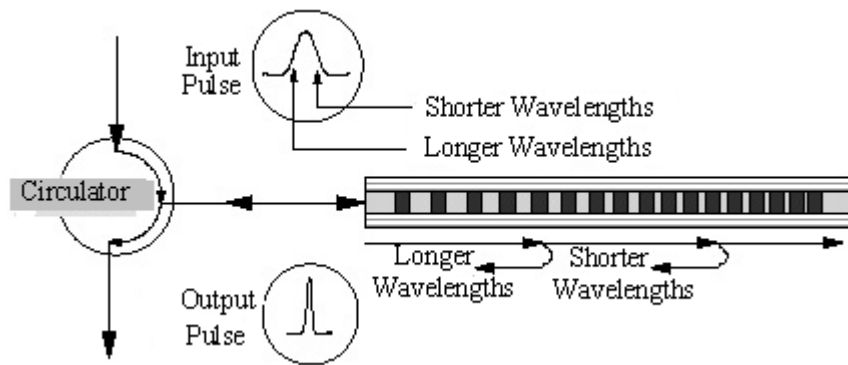

Figure 2.19: Dispersion Compensation with a Fiber Bragg Grating [12].

The major problem with chirped FBGs is that they have a ripple characteristic in the Group Velocity Dispersion (GVD) they produce. (The aim of a chirped FBG is to produce GVD in the opposite direction from that produced on the fiber link.) This ripple can be a source of transmission system noise. The longer grating is larger the problem with ripple and its resultant noise. In addition short FBGs are filters. When you process a signal through many stages of filtering you get a very narrow signal as a result and this can also distort and add noise to the signal.

## 2.13 Dispersion Management

It should be clear that with the advent of optical amplifiers, fiber losses are no longer a major limiting factor for optical communication systems. Indeed, modern light wave systems are often limited by the dispersive and nonlinear effects rather than fiber losses. In some sense, optical amplifiers solve the loss

problem but, at the same time, worsen the dispersion problem since, in contrast with electronic regenerators; an optical amplifier does not restore the amplified signal to its original state. As a result, dispersion-induced degradation of the transmitted signal accumulates over multiple amplifiers. For this reason, several dispersion-management schemes were developed during the 1990s to address the dispersion problem. The limitations imposed on the system performance by dispersion-induced pulse broadening, the group-velocity dispersion (GVD) effects can be minimized using a narrow-line width laser and operating close to the zero-dispersion wavelength  $\lambda_{ZD}$  of the fiber. However, it is not always practical to match the operating wavelength  $\lambda$  with  $\lambda_{ZD}$ . Such systems generally use the existing fiber-cable network installed during the 1980s and consisting of more than 50 million kilometers of the “standard” single-mode fiber with  $\lambda_{ZD} = 1.31\mu\text{m}$  since the dispersion parameter  $D \approx 16 \text{ ps}/(\text{km} - \text{nm})$  in the  $1.55 - \mu\text{m}$  region of such fibers, the GVD severely limits the performance when the bit rate exceeds 2 GB/s[13]

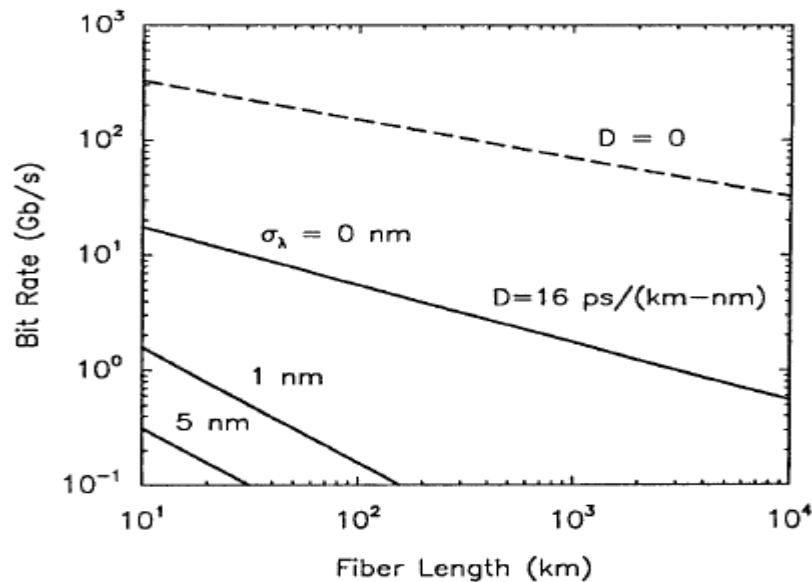

Figure 2.20: Limiting Bit Rate of Single-Mode Fibers [13]

Figure 2.20 show the limiting bit rate of single-mode fibers as a function of the fiber length for  $\sigma_{\lambda}=0,1,\text{and } 5 \text{ nm}$  the case  $\sigma_{\lambda}=0$  corresponds to the case of an optical source whose spectral width is much smaller than the bit rate [1].

Even when L increases by a factor of 10 because of the  $L^{-1/3}$  dependence of the bit rate ,n the fiber length. The dashed line in Fig. 2.19 shows this dependence by using Eq 2.1.

$$(B(|\beta_3|L)^{1/3} \leq 0.324 \quad (2.1)$$

When  $\beta_3 = 0.1 \text{ ps}^3 / \text{km}$ . Clearly, the performance of a light wave system can be improved considerably by operating it near the zero-dispersion wavelength of the fiber and using optical sources with a relatively narrow spectral width. For a directly modulated DFB laser, we can use Eq 2.2.

$$BL|D|\sigma_{\lambda} \leq \frac{1}{4} \quad (2.2)$$

For estimating the maximum transmission distance so that the [1].

$$L < (4B|D|S_{\lambda})^{-1} \quad (2.3)$$

Where  $S_{\lambda}$  is the root-mean-square (RMS) width of the pulse spectrum broadened considerably by frequency chirped Using  $D = 16 \text{ ps}/(\text{km-nm})$  and  $S_{\lambda} = 0.15 \text{ nm}$  in Eq(2.3 ), light wave systems operating at 2.5 Gb/s are limited to  $L \approx 42 \text{ km}$ . Indeed, such systems use electronic regenerators, spaced apart by about 40 km, and cannot benefit from the availability of optical amplifiers. Furthermore, their bit rate cannot be increased beyond 2.5 Gb/s because the regenerator spacing becomes too small to be feasible economically [16].

System performance can be improved considerably by using an external modulator and thus avoiding spectral broadening induced by frequency chirping. This option has become practical with the commercialization of transmitters containing DFB lasers with a monolithically integrated

modulator. The  $S_\lambda = 0$  line in Fig. 2.19 provides the dispersion limit when such transmitters are used with the standard fibers. The limiting transmission distance is then obtained by using the following Eq 2.4 [1].

$$\sigma^2 = \sigma_0^2 + (\beta_3 L / 4\sigma_0^2)^2 / 2 \equiv \sigma_0^2 + \sigma_D^2 \quad (2.4)$$

And is given by [1].

$$L < (16|\beta_2|B^2)^{-1} \quad (2.5)$$

Where  $\beta_2$  is the GVD coefficient related to D by [1].

$$D = \frac{d}{d\lambda} \left( \frac{1}{v_g} \right) = -\frac{2\pi c}{\lambda^2} \beta_2. \quad (2.6)$$

If we use typical value of  $\beta_2 = -20 \text{ ps}^2/\text{km}$ .

$1.55 \mu\text{m}, L < 500 \text{ km} \text{ at } \frac{2.5\text{Gb}}{\text{s}}$  Although improved considerably compared with the case of directly modulated DFB lasers, this dispersion limit becomes of concern when in-line amplifiers are used for loss compensation. Moreover, if the bit rate is increased to 10 Gb/s, the GVD-limited transmission distance drops to 30 km, a value so low that optical amplifiers cannot be used in designing such lightwave systems. It is evident from Eq. (2.6) that the relatively large GVD of standard single-mode fibers severely limits the performance of 1.55- $\mu\text{m}$  systems designed to use the existing telecommunication network at a bit rate of 10 Gb/s or more.

A dispersion-management scheme attempts to solve this practical problem. The basic idea behind all such schemes is quite simple and can be understood by using the pulse-propagation equation and written as:

$$\frac{\partial A}{\partial z} + \frac{i\beta_3}{\partial t^2} \frac{\partial^2 A}{\partial t^2} + \frac{\beta_3}{6} \frac{\partial^3 A}{\partial t^3} = 0 \quad (2.7)$$

Where:

A is the pulse-envelope amplitude. The effects of third-order dispersion are included by the  $\beta_3$  term. In practice, this term can be neglected



when  $|\beta_2|$  exceeds  $0.1 \text{ ps}^2/\text{km}$  Eq(2.5) has been solved [1] and the solution is given by [1]:  $A(z, t) = \frac{1}{2\pi} \int_{-\infty}^{\infty} \tilde{A}(0, \omega) \exp\left(\frac{i}{2}\beta_2 z \omega^2 + \frac{i}{6}\beta_3 z \omega^3 - i\omega t\right) d\omega$ , In the specific case of  $\beta_3 = 0$  the solution becomes:

$$A(z, t) = \frac{1}{2\pi} \int_{-\infty}^{\infty} \tilde{A}(0, \omega) \exp\left(\frac{i}{2}\beta_2 z \omega^2 - i\omega t\right) d\omega, \quad (2.8)$$

Where  $\{\tilde{A}(0, \omega)\}$  is the Fourier transform of  $A(0, t)$ .

Dispersion-induced degradation of the optical signal is caused by the phase factor  $\exp\{(i\beta_2 z \omega^2 / 2)\}$  acquired by spectral components of the pulse during its propagation in the fiber. All dispersion-management schemes attempt to cancel this phase factor so that the input signal can be restored. Actual implementation can be carried out at the transmitter, at the receiver, or along the fiber link [10].

- **Precompensation Schemes**

This approach to dispersion management modifies the characteristics of input pulses at the transmitter before they are launched into the fiber link. The underlying idea can be understood from Eq. (2.8). It consists of changing the spectral amplitude  $\{\tilde{A}(0, \omega)\}$  of the input pulse in such a way that GVD-induced degradation is eliminated, or at least reduced substantially, clearly if the spectral amplitude is changed as [1].

$$\tilde{A}(0, \omega) \rightarrow \tilde{A}(0, \omega) \exp(-i\omega^2 \beta_2 L / 2) \quad (2.9)$$

Where  $L$  is the fiber length, GVD will be compensated exactly, and the pulse will retain its shape at the fiber output. Unfortunately, it is not easy to implement Eq. (2.9) in practice. In a simple approach, the input pulse is chirped suitably to minimize the GVD-induced pulse broadening. Since the frequency chirp is applied at the transmitter before propagation of the pulse, this scheme is called the prechirp technique. The more important precompensation schemes are [14]

- i. Prechirp Technique.
- ii. Novel Coding Techniques.
- iii. Nonlinear Prechirp Techniques.

• **Postcompensation Techniques**

Electronic techniques can be used for compensation of GVD within the receiver. The philosophy behind this approach is that even though the optical signal has been degraded by GVD, one may be able to equalize the effects of dispersion electronically if the fiber acts as a linear system. It is relatively easy to compensate for dispersion if a heterodyne receiver is used for signal detection [15]. A heterodyne receiver first converts the optical signal into a microwave signal at the intermediate frequency  $\omega_{IF}$  while preserving both the amplitude and phase information. A microwave bandpass filter whose impulse response is governed by the transfer function [16]

$$H(\omega) \exp[-i(\omega - \omega_{IF})^2 \beta_2 L/2] \tag{2.10}$$

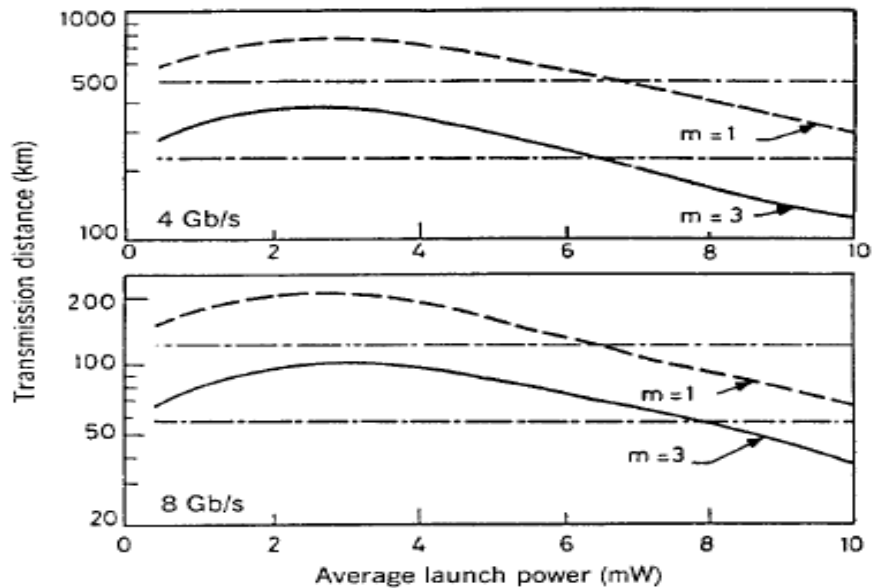

Figure 2.21: Dispersion-Limited Transmission Distance [16].

Figure 2.20 shown the dispersion-limited transmission distance as a function of launch power for Gaussian ( $m = 1$ ) and super-Gaussian ( $m = 3$ ) pulses at bit rates of 4 and 8 Gb/s. Horizontal lines correspond to the linear case  $\{1\}$ . Where  $L$  is the fiber length, should restore to its original form the signal received. This conclusion follows from the standard theory of linear systems [1] by using Eq. (2.8) with  $z=L$ . This technique is most practical for dispersion compensation in coherent light wave systems. In a 1992 transmission experiment, a 31.5-cm-long micro strip line was used for dispersion equalization. Its use made it possible to transmit the 8-Gb/s signal over 188 km of standard fiber having a dispersion of 18.5ps/(km-nm). In a 1993 experiment, the technique was extended to homodyne detection using single-side band transmission, and the 6-Gb/s signal could be recovered at the receiver after propagating over 270 km of standard fiber. Micro strip lines can be designed to compensate for GVD acquired over fiber lengths as long as 4900 km for a light wave system operating at a bit rate of 2.5 Gb/s[10].

Use of a coherent receiver is often not practical. An electronic dispersion equalizer is much more practical for a direct-detection receiver. A linear electronic circuit cannot compensate GVD in this case. The problem lies in the fact that all phase information is lost during direct detection as a photo detector responds to optical intensity only [17]As a result, no linear equalization technique can recover a signal that has spread outside its allocated bit slot. Nevertheless, several nonlinear equalization techniques have been developed that permit recovery of the degraded signal. In one method, the decision threshold, normally kept fixed at the center of the eye diagram [1,4], is varied depending on the preceding bits. In another, the decision about a given bit is made after examining the analog waveform over a multiple-bit interval surrounding the bit in question. The main difficulty with all such

techniques is that they require electronic logic circuits, which must operate at the bit rate and whose complexity increases exponentially with the number of bits over which an optical pulse has spread because of GVD-induced pulse broadening. Consequently, electronic equalization is generally limited to low bit rates and to transmission distances of only a few dispersion lengths. An optoelectronic equalization technique based on a transversal filter has also been proposed. In this technique, a power splitter at the receiver splits the received optical signal into several branches. Fiber-optic delay lines introduce variable delays in different branches. The optical signal in each branch is converted into photocurrent by using variable-sensitivity photo detectors, and the summed photocurrent is used by the decision circuit. The technique can extend the transmission distance by about a factor of 3 for a light wave system operating at 5 Gb/s[16]

- **Dispersion-Compensating Fibers**

The preceding techniques may extend the transmission distance of a dispersion-limited system by a factor of 2 or so but are unsuitable for long-haul systems for which GVD must be compensated along the transmission line in a periodic fashion. What one needs for such systems is an all-optical, fiber-based, dispersion-management technique. A special kind of fiber, known as the dispersion-compensating fiber (DCF), has been developed for this purpose as mentioned before. The use of DCF provides an all-optical technique that is capable of compensating the fiber GVD completely if the average optical power is kept low enough that the nonlinear effects inside optical fibers are negligible. It takes advantage of the linear nature of Eq. (2.6). To understand the physics behind this dispersion-management technique, consider the situation in which each optical pulse propagates through two fiber segments,

the second of which is the DCF. Using Eq. (2.8) for each fiber section consecutively, we obtain [18].

$$A(L, t) = \frac{1}{2\pi} \int_{-\infty}^{\infty} \exp \left[ \frac{i}{2} \omega^2 (\beta_{21} L_1 + \beta_{22} L_2) - i\omega t \right] d\omega \quad (2.11)$$

Where:

$L = L_1 + L_2$ , and  $\beta_{2i}$  is GVD parameter for the fiber segment of length  $L_j$  ( $j=1, 2$ ).

If the DCF is chosen such that the  $\omega^2$  phase term vanishes, the pulse will recover its original shape at the end of DCF. The condition for perfect dispersion compensation is thus  $\beta_{21} L_1 + \beta_{22} L_2 = 0$ , or [16].

$$D_1 L_1 + D_2 L_2 = 0 \quad (2.12)$$

Eq (2.12) shows that the DCF must have normal GVD at 1.55  $\mu\text{m}$   $D_2 < 0$  because  $D_1 > 0$  for standard telecommunication fibers. Moreover, its length should be chosen to satisfy [1]

$$L_2 = -(D_1/D_2)L_1 \quad (2.13)$$

For practical reasons,  $L_2$  should be as small as possible. This is possible only if the DCF has a large negative value of  $D_2$ .

A practical solution for upgrading the terrestrial light wave systems making use of the existing standard fibers consists of adding a DCF module (with 6–8 km of DCF) to optical amplifiers spaced apart by 60–80 km. The DCF compensates GVD while the amplifier takes care of fiber losses. This scheme is quite attractive but suffers from two problems. First, insertion losses of a DCF module typically exceed 5 dB. Insertion losses can be compensated by increasing the amplifier gain but only at the expense of enhanced amplified spontaneous emission (ASE) noise. Second, because of a relatively small mode diameter of DCFs, the effective mode area is only  $\sim 20 \mu\text{m}^2$ . As the

optical intensity is larger inside a DCF at a given input power, the nonlinear effects are considerably enhanced. The problems associated with a DCF can be solved to a large extent by using a two mode fiber designed with values of  $V$  such that the higher-order mode is near cutoff ( $V \approx 2.5$ ). Such fibers have almost the same loss as the single-mode fiber but can be designed such that the dispersion parameter  $D$  for the higher-order mode has large negative values. Indeed, values of  $D$  as large as  $-770$  ps/(km-nm) have been measured for elliptical-core fibers. A 1-km length of such a DCF can compensate the GVD for a 40-km-long fiber link, adding relatively little to the total link loss. The use of a two-mode DCF requires a mode-conversion device capable of converting the energy from the fundamental mode to the higher-order mode supported by the DCF. Several such all-fiber devices have been developed. The all-fiber nature of the mode-conversion device is important from the standpoint of compatibility with the fiber network. Moreover, such an approach reduces the insertion loss. Additional requirements on a mode converter are that it should be polarization insensitive and should operate over a broad bandwidth. Almost all practical mode-conversion devices use a two-mode fiber with a fiber grating that provides coupling between the two modes. The grating period  $\Lambda$  is chosen to match the mode-index difference  $\delta\tilde{n}$  of the two modes ( $\Lambda = \lambda / \delta\tilde{n}$ ) and is typically **100**  $\mu\text{m}$ . Such gratings are called long-period fiber gratings. Figure 2.21 shows schematically a two-mode DCF with two long-period gratings. The measured dispersion characteristics of this DCF are also shown. The parameter  $D$  has a value of  $-420$  ps/(km-nm) at 1550 nm and changes considerably with wavelength. This is an important feature that allows for broadband dispersion compensation. In general, DCFs are designed such that  $|D|$  increases with wavelength. The wavelength dependence of  $D$

plays an important role for wavelength-division multiplexed (WDM) systems [6].

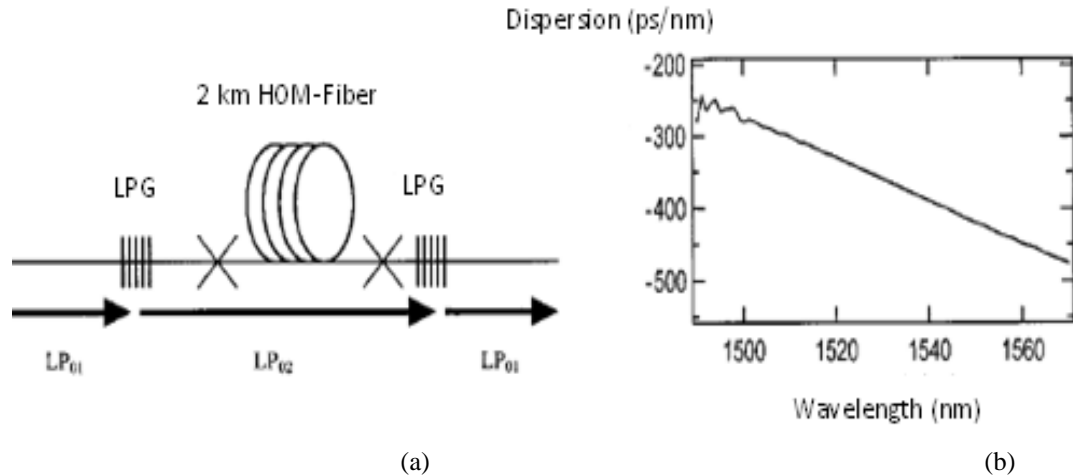

Figure 2.22: schematic of a DCF made using a higher-order mode (HOM),(a)Schematic of a DCF(b) Dispersion Spectrum of the DCF[2].

- **Optical Filters**

A shortcoming of DCFs is that a relatively long length ( $> 5$  km) is required to compensate the GVD acquired over 50 km of standard fiber. This adds considerably to the link loss, especially in the case of long-haul applications. For this reason, several other all-optical schemes have been developed for dispersion management. Most of them can be classified under the category of optical equalizing filters. Interferometric filters are considered in this section. The function of optical filters is easily understood from Eq. (2.8). Since the GVD affects the optical signal through the spectral phase  $\exp(i\beta_2 z\omega^2)/2$ , it is evident that an optical filter whose transfer function cancels this phase will restore the signal. Unfortunately, no optical filter (except for an optical fiber) has a transfer function suitable for compensating the GVD exactly.

Nevertheless, several optical filters have provided partial GVD compensation by mimicking the ideal transfer function. Consider an optical filter with the transfer function  $H(\omega)$ . If this filter is placed after a fiber of length  $L$ , the filtered optical signal can be written using Eq. (2.8) as [21].

$$A(L, t) = \frac{1}{2\pi} \int_{-\infty}^{\infty} \tilde{A}(0, \omega) H(\omega) \exp\left(\frac{i}{2} \beta_2 L \omega^2 - i\omega t\right) d\omega, \quad (2.14)$$

Figure 2.23 show dispersion management in a long-haul fiber link using optical filters after each amplifier. Filters compensate for GVD and also reduce amplifier noise [22].

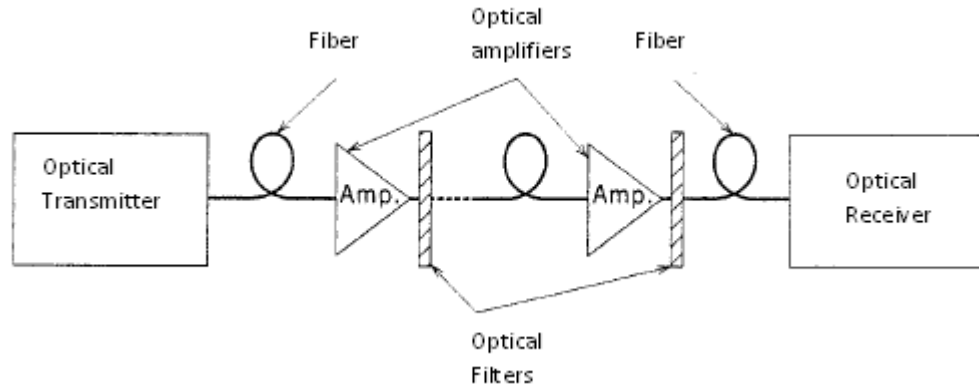

Figure 2.23: Dispersion Management in a Long-Haul Fiber Link [22].

- **Fiber Bragg Gratings**

A fiber Bragg grating acts as an optical filter because of the existence of a stop band, the frequency region in which most of the incident light is reflected back. The stop band is centered at the Bragg wavelength  $\lambda_B = 2\bar{n}\Lambda$ , where  $\Lambda$  is the grating period and  $\bar{n}$  is the average mode index. The periodic nature of index variations couples the forward- and backward-propagating waves at wavelengths close to the Bragg wavelength and, as a result, provides frequency-dependent reflectivity to the incident signal over a bandwidth determined by the grating strength. In essence, a fiber grating



acts as a reflection filter. Although the use of such gratings for dispersion compensation was proposed in the 1980s, it was only during the 1990s that fabrication technology advanced enough to make their use practical [17].

- i. Uniform-Period Gratings.
- ii. Chirped Fiber Gratings.
- iii. Chirped Mode Couplers.

- **Optical Phase Conjugation**

Although the use of optical phase conjugation (OPC) for dispersion compensation was proposed in 1979, it was only in 1993 that the OPC technique was implemented experimentally; it has attracted considerable attention since then[19].

- i. Principle of Operation.
- ii. Compensation of Self-Phase Modulation.
- iii. Phase-Conjugated Signal.

- **Long-Haul Light wave Systems**

This section focused on light wave systems in which dispersion management helps to extend the transmission distance from a value of **~10 km** to a few hundred kilometers. The important question is how dispersion management can be used for long-haul systems for which transmission distance is several thousand kilometers. If the optical signal is regenerated electronically every 100–200 km, all techniques discussed in this section should work well since the nonlinear effects do not accumulate over long lengths. In contrast, if the signal is maintained in the optical domain over the entire link by using periodic amplification, the nonlinear effects such as SPM, cross phase modulation (XPM), and FWM would limit the system ultimately. Indeed, the impact of nonlinear effects on the performance of dispersion-managed systems has been a subject of intense study [20]

- i. Periodic Dispersion Maps.
- ii. Simple Theory.
- iii. Intra channel Nonlinear Effects.

- **High-Capacity Systems**

Modern WDM light wave systems use a large number of channels to realize a system capacity of more than 1 Tb/s. For such systems, the dispersion-management technique should be compatible with the broad bandwidth occupied by the multichannel signal [21]

- i. Broadband Dispersion Compensation.
- ii. Tunable Dispersion Compensation.
- iii. Higher-Order Dispersion Management.
- iv. PMD Compensation.

➤ **Compensation at Receiver**

- Adjust decision point on the fly based on previous few bits
- Mathematically extrapolate signal back to what it presumably was at origin
- These techniques can be used only if calculations can be done much faster than bit rate. Dispersion properties of Various Fiber as show in figure 2.24

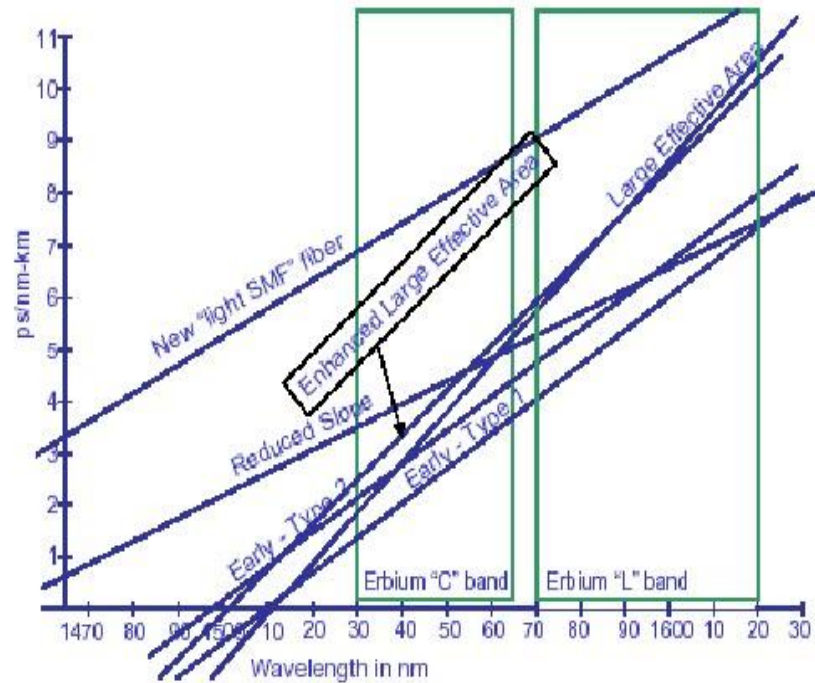

Figure 2.24 .Dispersion of various fiber types as a function of wave length [19]

## 2.14 Related work

- ▶ In [3] the author made analysis for dispersion compensation with dispersion compensating fibers (DCF) at 10Gbits/sec for 250 km of SMF and 50 km of DCF. Three schemes of dispersion compensation (pre-, post-, and symmetrical/mix-compensation) with DCF are proposed .three dispersion compensation methods are compared in terms of four parameter, which are Q-factor, BER, Eye height and threshold value, investigated at the receiver end. After analysis, we find that the symmetrical/mix-dispersion compensation scheme is better than pre and post-compensation schemes. To obtain better signal at receiving end.
- ▶ In [4], the dispersion management scheme is taken into account by employing a Fiber Bragg Grating technology. The in line dispersion is compensated using a real grating component for a 100 km fiber. The results

are validated by comparing the Q factor of the FBG simulated model for before compensation and after compensation.

- ▶ In [12] the researcher simulated the performance effective fiber optic communication by optical phase conjugation for a multichannel system in dispersion. In the phase conjugation method of Four-Wave Mixing (FWM), three input waves interact in a nonlinear medium to produce a fourth complex conjugate of one of the input fields. The fourth wave can be either forward-going or backward-going that depends on the geometry of the setup. The OPC technique is implemented using by using the DCF and the nonlinear effect FWM. In FWM, wavelength conversion is performed which is obtained before the Highly Non-Linear Fiber (HNLFF). Then it is exactly shifted to another wavelength after it but problem in limited and insertion losses.
- ▶ In [10] the researcher simulated the electronic equalizer technique for nonlinear dispersion compensation in optical fiber communications links and develops, analyze, and test an electronic nonlinear fiber-optic electronic circuit is reviewed. The most significant accomplishments and findings are highlighted and then weighed against the shortcomings of the approach and implementation but problem is specific circuit implementation and slows down the speed of communication since it slows down the digital to analog conversion.
- ▶ In [9] the researcher simulated optical communication system in an information transmission. As soon as we saw dispersion, we decided to compensate it in mandate to receive data at receiver. For this purpose, we used chirp FBG and simulated it. Also, it can be obtained that increase in grating length leads to decrease in pulse extension, and also increase in power. Lastly, it can be understood that the pulse was broadened and its

power is increased as a result of the increase in the chirp parameter which is the best volume.

- ▶ In this project we will use Compensation By using Ideal Dispersion Component.

# **CHAPTER THREE**

## **System Design**

# Chapter Three: System Design

## 3.1 Overview

Chapter three is one of the important parts that act as the guidelines in order to accomplish the research. This chapter describes the details explanation of the methodology that has been used in this research. The most important aspect during the methodology stage is a theoretical model of dispersion compensations system for analysis was developed. The parameters that have been used in this research are clearly stated. The design of dispersion compensations system of analysis and simulation process at various dispersion compensations. Is layed out the simulation parameters in Ideal dispersion compensations involved in the research an explained.

## 3.2 Modeling

Modeling is done by using the mathematical equations of the GVD and Ideal dispersion fiber bragg grating component.

### 3.2.1 Group Velocity

In a simple word the group velocity is the usual way of discussing the speed of propagation on a fiber. The group velocity of a wave is the velocity with which the overall shape of the wave's amplitudes known as the modulation or envelope of the wave propagates through space. It represents the actual velocity which the signal information & energy is traveling down the fiber. The group delay measures change in transit time with wavelength through z km fiber.

### 3.2.2 Wave Velocities

Plane wave velocity: For a plane wave propagating along z-axis in an unbounded homogeneous region of refractive index  $n_1$ , which is represented by  $\exp(j\omega t - jk_1 z)$ , the velocity of constant phase plane where

$$v = \frac{\omega}{k_1} = \frac{c}{n_1} \quad (3.1)$$

**3.2.3 Modal wave phase velocity:** For a modal wave propagating along z-axis represented by  $\exp(j\omega t - j\beta z)$  the velocity of constant phase plane is:

$$v_p = \frac{\omega}{\beta} \quad (3.2)$$

For transmission system operation the most important & useful type of velocity is the group velocity,  $v_g$ . This is the actual velocity which the signal information and energy is traveling down the fiber. It is always less than the speed of light in the medium. The observable delay experiences by the optical signal waveform and energy, when traveling a length of along the fiber is commonly referred to as group delay. The equations explain of Group Velocity and Group Delay[22].

- The group velocity is given by:

$$V_g = \frac{d\omega}{d\beta} \quad (3.3)$$

- The group delay is given by:

$$\tau_g = \frac{l}{V_g} = l \frac{d\beta}{d\omega} \quad (3.4)$$

- It is important to note that all above quantities depend both on frequency & the propagation mode. In order to see the effect of these parameters on group velocity and delay, the following analysis would be helpful.
- The definition of chirp where the chirp (C) is defined by the change in frequency  $d\omega$  due to the rate of change of the phase:



$$d\omega = -\frac{d\phi}{dt} = \frac{Ct}{\tau^2} \quad (3.5)$$

$\tau$  is the initial 1/e duration of the pulse.

Spread of Gaussian Pulse

$$\frac{\sigma^2}{\sigma_0^2} = \left(1 + \frac{C\beta_2 L}{2\sigma_0^2}\right)^2 + \left(\frac{\beta_2 L}{2\sigma_0^2}\right)^2 + (1 + C^2)^2 \left(\frac{\beta_3 L}{4\sigma_0^3 \sqrt{2}}\right)^2 \quad (3.6)$$

### 3.2.4 Effects of Group Velocity Dispersion (GVD).

These demonstrate the influence of the group (GVD) velocity dispersion on pulse propagation in optical fibers in "linear" regime. The basic effects related to GVD are:

- i. GVD induced pulse broadening.
- ii. GVD induced pulse chirping.
- iii. Pulse compression.

The equation, which describes the effect of GVD on optical pulse propagation neglecting the losses and nonlinearities[23], is:

$$i \frac{\partial E}{\partial z} = \frac{\beta_2}{2} \frac{\partial^2 E}{\partial t^2} \quad (3.7)$$

Where the  $z$  =the propagation direction= is the time= is the electric field envelope, and

$$\beta_2 = \frac{\partial^2 \beta}{\partial \omega^2} \quad (3.8)$$

Is the GVD parameter, defined as the second derivative of the fiber mode propagation constant with value to frequency. For an input pulse with a Gaussian shape,

$$E(z = 0, t) = \sqrt{p_0} \exp\left[-\frac{t^2}{2T_0^2}\right] \quad (3.9)$$

The pulse width  $T_0$  (related to the pulse full width at half maximum by  $T_{FWHM} \approx 1.665T_0$ ) increases with  $z$  (the pulse broadens) according to:

$$T(z) = \left[ 1 + \left( \frac{z}{L_D} \right)^2 \right]^{1/2} T_0 \quad (3.10)$$

And, consequently, the peak power changes, due to GVD, are given by:

$$P(z) = \frac{P_0}{\left[ 1 + \left( \frac{z}{L_D} \right)^2 \right]^{1/2}} \quad (3.11)$$

In Equation (3.10) and Equation (3.11), the quantity

$$L_D = \frac{T_0^2}{|\beta_2|} \quad (3.12)$$

$L_D$  = the dispersion length.

Its meaning is quite straightforward: after propagating a distance equal to  $L_D$  the pulse broadens by a factor of  $\sqrt{2}$ . To demonstrate this, we created the following simple circuit. Waveguide dispersion in single mode fibers

- For single mode fibers, waveguide dispersion is in the same order of material dispersion. The pulse spread can be well approximated as:

$$\sigma_{wg} \approx \left| \frac{d\tau_{wg}}{d\lambda} \right| \sigma_\lambda = L \sigma_\lambda \left| D_{wg}(\lambda) \right| = \frac{n_2 L \Delta \sigma_\lambda}{c \lambda} V \frac{d^2(Vb)}{dV^2} \quad (3.13)$$

### 3.3 Design

The design is done by drawing the figures of component to describe GVD and Ideal dispersion component.

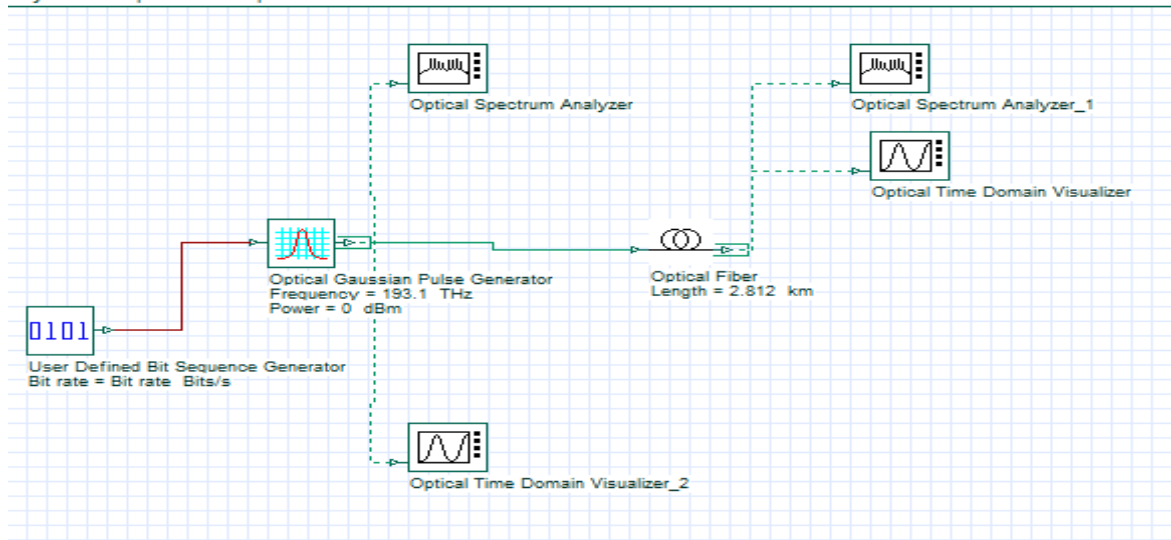

Figure 3.1 GVD block diagram

Bill of materials - OptiSystem provides a cost analysis table of the system being designed, arranged by system, layout or component. As shown in figure 3.2.

Bill of Materials	
Bill of Materials	
<b>Unchirped Gaussian pulse</b>	
Component Name	Cost
Optical Fiber	0.000000
Optical Spectrum Analyzer	0.000000
Optical Time Domain Visualizer_2	0.000000
Optical Spectrum Analyzer_1	0.000000
User Defined Bit Sequence Generator	0.000000
Optical Time Domain Visualizer	0.000000
Optical Gaussian Pulse Generator	0.000000
<b>Total Cost</b>	<b>0.000000</b>

Figure 3.2: GVD Project Bill of Materials configuration profile

Figure 3.3a show the optical fiber properties length and figure 3.3b group velocity dispersion.

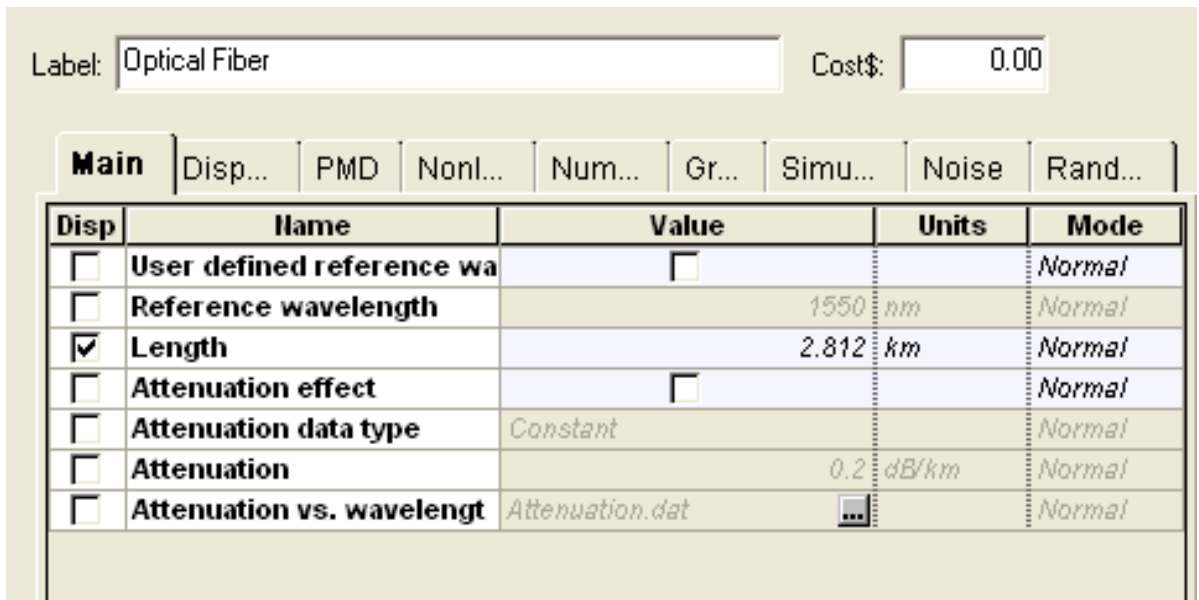

(a)

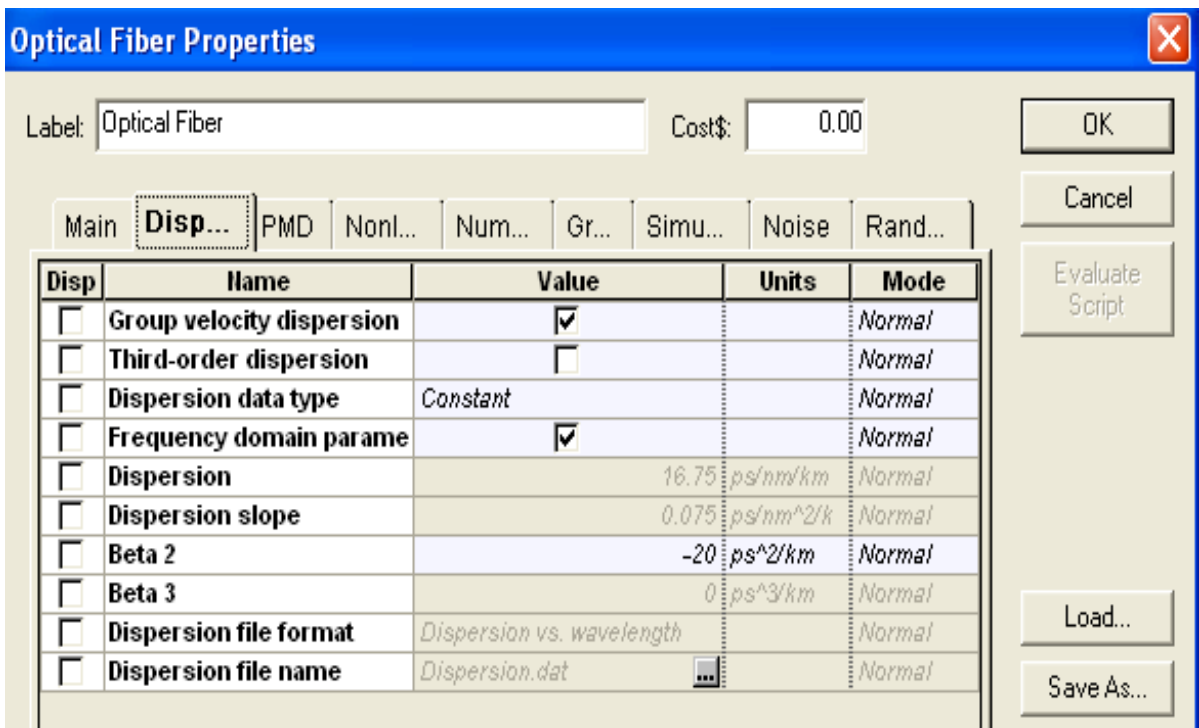

(b)

Figure 3.3: Optical Fiber Properties, (a) Length of fiber (b) group velocity dispersion

The figure 3.4 demonstrates the possibility for dispersion compensation with the help of ideal dispersion component in OptiSystem. The project layout is shown below.

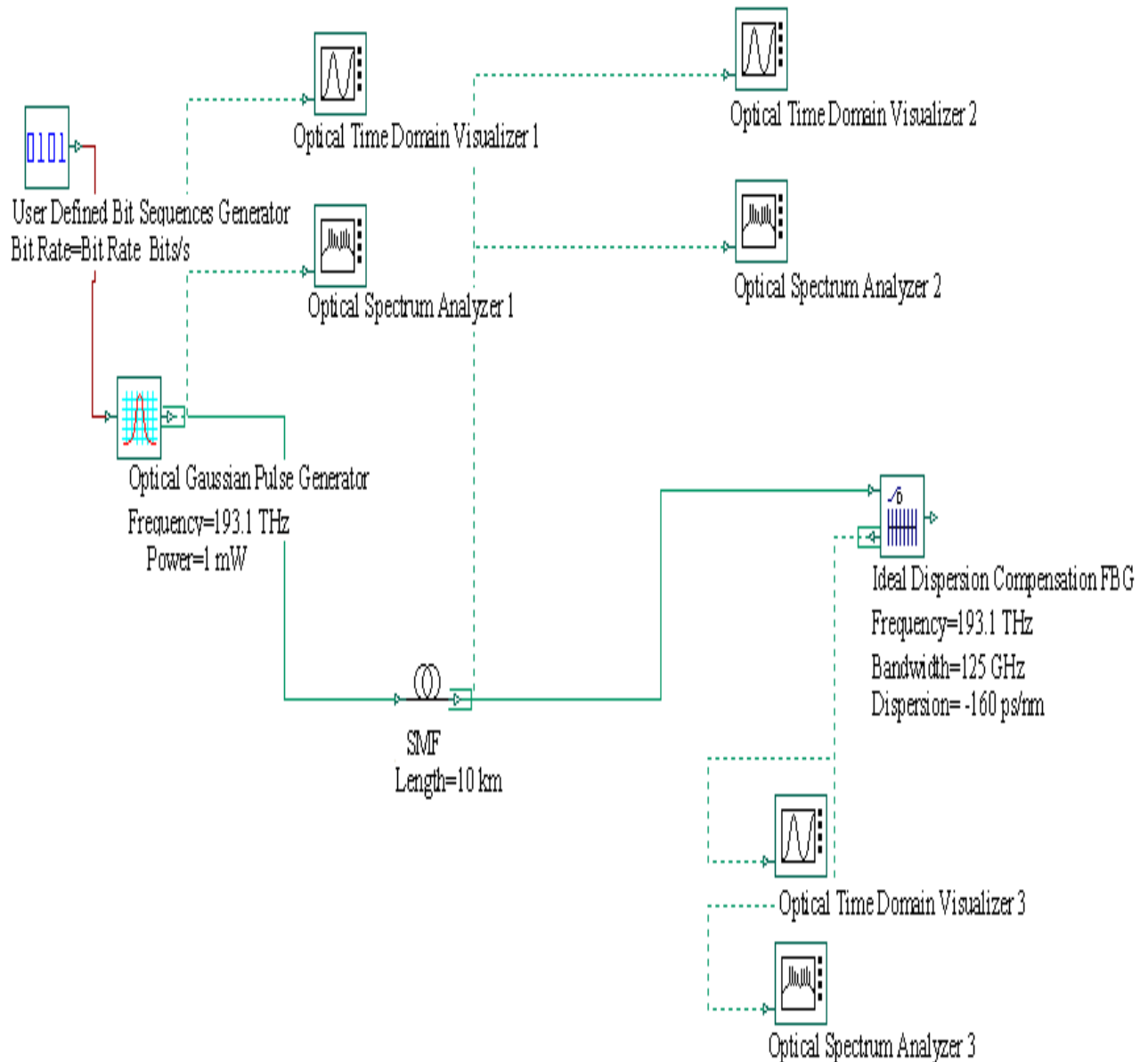

Figure 3.4 Compensation with Ideal Dispersion Component design

Component Name	Cost
Optical Time Domain Visualizer 1	0.000000
Optical Spectrum Analyzer 1	0.000000
Optical Spectrum Analyzer 2	0.000000
User Defined Bit Sequence Generator	0.000000
Optical Time Domain Visualizer 2	0.000000
Optical Gaussian Pulse Generator	0.000000
Ideal Dispersion Compensation FBG	0.000000
Optical Spectrum Analyzer 3	0.000000
Optical Time Domain Visualizer 3	0.000000
SMF	0.000000
<b>Total Cost</b>	<b>0.000000</b>

Figure 3.5 Bill of Materials and simulation

Figure 3.6 shown the compensation with ideal dispersion component design with the following parameter such as bit rate

Name	Value	Units	Mode
Simulation window	Set bit rate		Normal
Reference bit rate	<input checked="" type="checkbox"/>		Normal
Bit rate	40000000000	Bits/s	Normal
Time window	4e-010	s	Normal
Sample rate	512000000000	Hz	Normal
Sequence length	16	Bits	Normal
Samples per bit	128		Normal
Number of samples	2048		Normal

Figure 3.6: Compensation of Dispersion Ideal Dispersion Compensation

Figure 3.7 show the compensation with ideal dispersion component design with the following parameters such as frequency, bandwidth and dispersion.

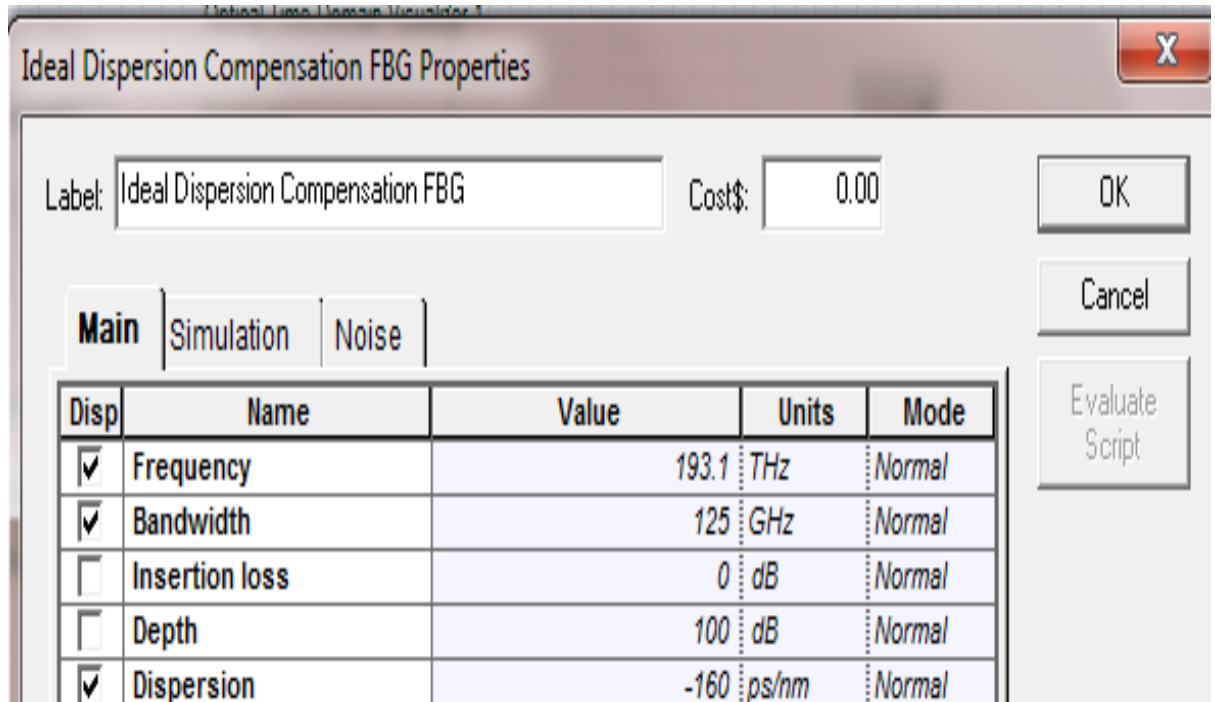
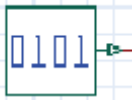
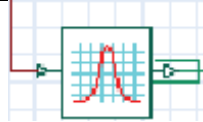

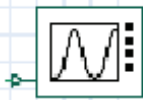

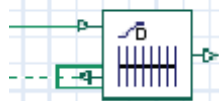

Figure 3.7: Ideal Dispersion Compensation FBG configuration profile

### 3.4 Simulation:

OptiSystem Software is used to demonstrate the influence of the group velocity dispersion (GVD) on Gaussian pulse propagation. The Bill of material used to demonstrate the influence of the (GVD) on pulse propagation in optical fibers in "linear" regime to demonstrate the Compensation of dispersion with Ideal dispersion component in OptiSystem as described the following in table 4-1

Table 3.1: Optical Design components

No	Figure	Component
1		User Defined Bit Sequence Generator
2		Optical Gaussian pulse Generator.
3		Optical Spectrum Analyzer.
4		Optical Time Domain Visualizer.
5		Optical Fiber.
6		Ideal dispersion component.

### 3.4.1 Compensation of Dispersion with Ideal Dispersion Component:

The most major features for the Ideal Dispersion Component are

- Large negative dispersion coefficient
- Low attenuation
- Minimal nonlinear contributions
- Wide bandwidth
- Corrects dispersion slope as well
- Minimal ripple
- Polarization independent
- Manufacturable



### 3.5 Verification

We run the simulation under this configuration, the obtain result should show that the pulse is broadened (the peak power decreases).The most major important factors to set are:

- i.Bit rate.
- i. Bit duration.
- ii. Value for width.
- iii. Fiber length (Dispersion length).

To demonstrates the possibility of dispersion compensation with the help of Ideal Dispersion Component in OptiSystem. We use the same last circuit and components with the same values, in addition to Ideal Dispersion Component; the major parameter to demonstrate this is frequency; bandwidth and dispersion parameter.

# **CHAPTER FOUR**

## **RESULTS AND DISCUSSION**

## Chapter Four: Results and Discussion

### 4.1 Demonstration the Effects of Group Velocity Dispersion

The project calculated and the obtained results are presented in Figure (4.1). We see that the pulse is broadened (the peak power decreases in accordance with Equation (3. 11)). The origin of pulse broadening can be understood by looking at the instant frequency of the pulse, namely the chirp.

Optical Time Domain Visualizer: Displays the modulated optical signal in the time domain. The simulation result of the optical fiber in time domain the signal input in fiber the value of power 1mw is show in figure 4.1a and without using ideal dispersion component in figure 4.1 b regarding to the input signal, power decrease from 1mw to 0.72mw.

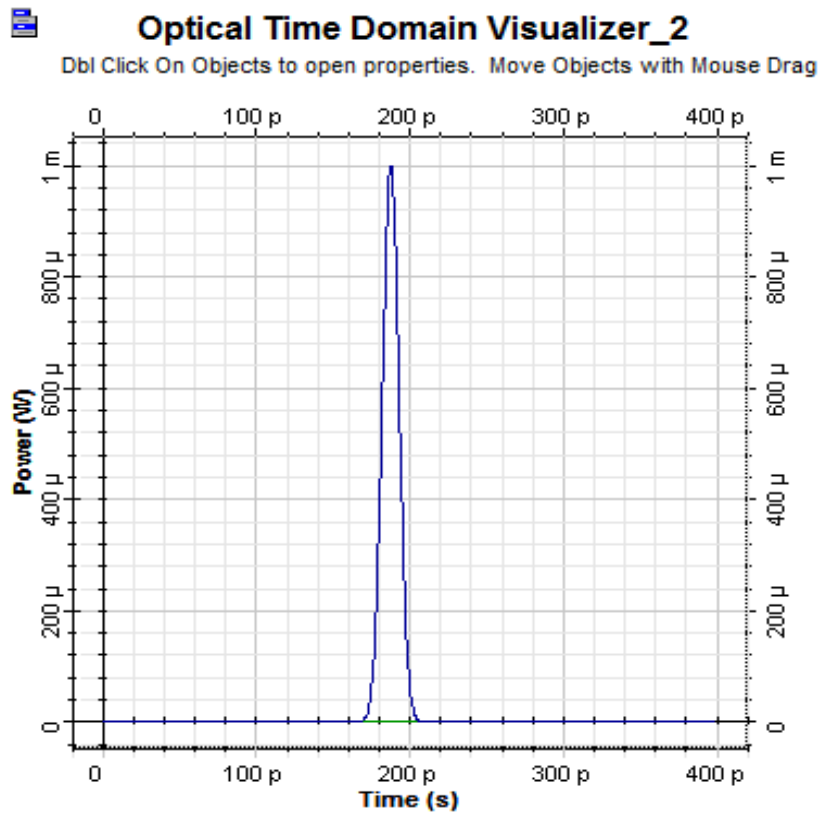

(a)

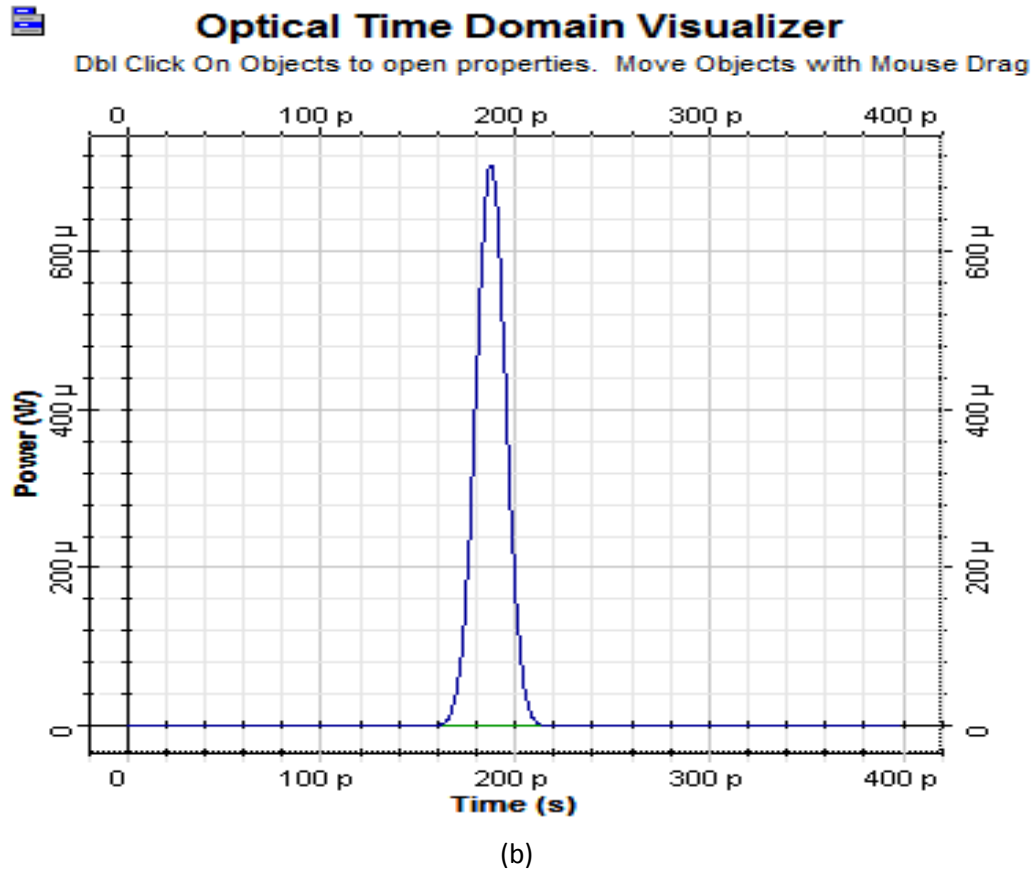

(b)

Figure 4.1: Input Pulse and Output Pulse of Effect GVD on Gaussian Pulse Propagation,(a)Optical Time Domain Visualizer\_2 (Input) (b)Optical Time Domain Visualizer (Output).

These showed in Figure (4.2a), where the pulse chirp is plotted together with the pulse intensity. Where the input pulse is chirp less, the instantaneous frequency of the output pulse decreases from the leading to the trailing edge of the pulse. The reason for this is GVD. In the case of anomalous GVD ( $\beta_2 < 0$ ), the higher frequency ("blue-shifted") components of the pulse travel faster than the lower frequency (or "red-shifted") ones .figure 4.2b chirped pulse and broadened pulse after the dispersion length (LD) of the fiber Observing the leading and trailing edges tend to blue and red shifts.

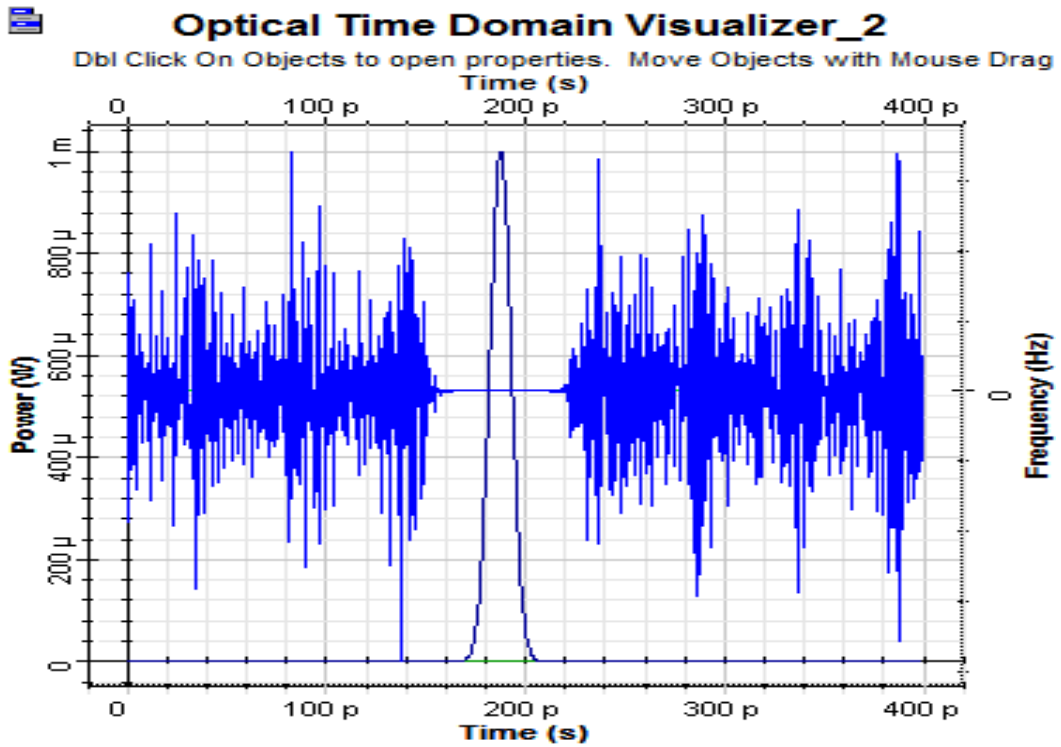

(a)

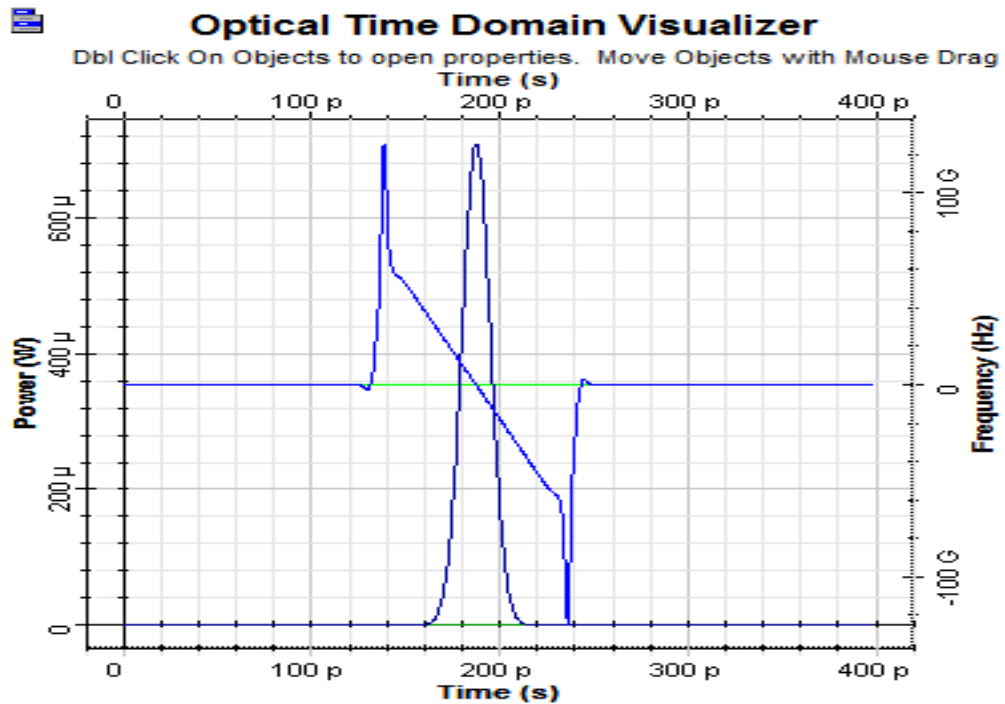

(b)

Figure 4.2: Pulse Chirp Plotted with Intensity Pulse,(a)Optical Time Domain Visualizer\_2 (Input)(b) Optical Time Domain Visualizer (Output) .

Note: The leading edge of the pulse is blue shifted and the trailing edge of the pulse is red-shifted. Because the "blue" and "red" spectral components tend to separate in time, this leads to pulse broadening. However, the pulse spectrum remains unchanged, as Figure (4.3) .Optical Spectrum Analyzer: Displays the modulated optical signal in the frequency domain

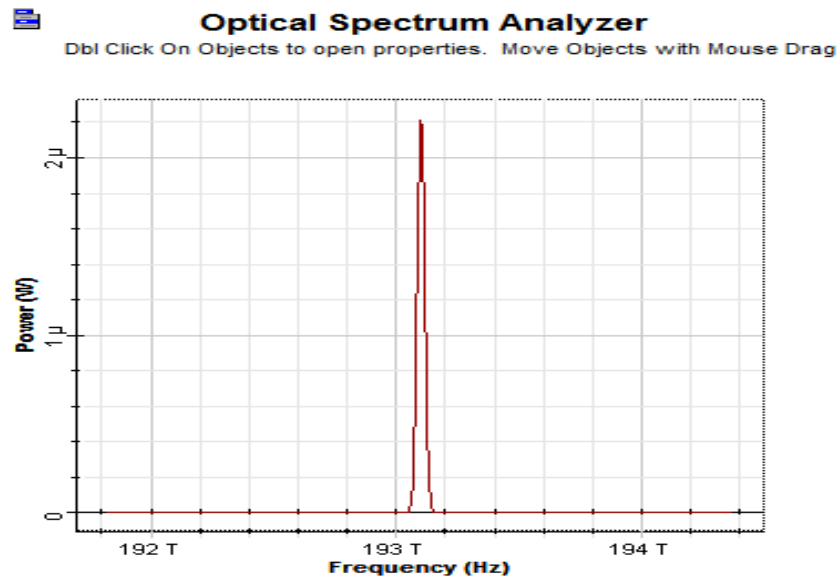

(a)

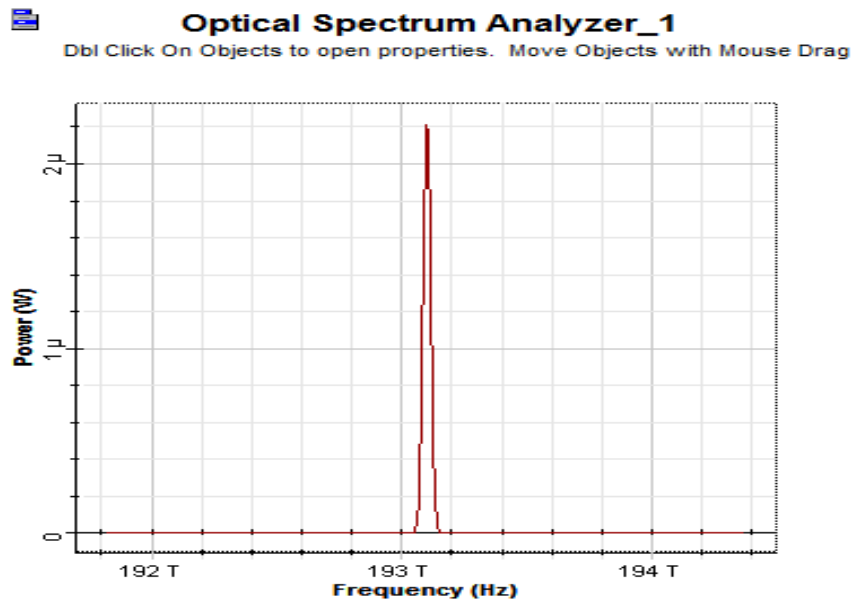

(b)

Figure 4.3: Spectra Corresponding to Figure 4.1 and 4.2,(a)Optical Spectrum Analyzer 1 (Input) (b)Optical Spectrum Analyzer 2 (Output).

If the input pulse is frequency modulated (i.e. chirped), Equation (3. 9) is replaced by:

$$E(z = 0, t) = \sqrt{p_0} \exp\left(1 \frac{1+iC}{2} \frac{t^2}{T_0^2}\right) \quad (4.1)$$

And the expression for the dependence of the pulse width on z is [1]

$$T(z) = T_0 \left[ \left(1 + \frac{C\beta_2 z}{T_0^2}\right)^2 + \left(\frac{\beta_2 z}{T_0^2}\right)^2 \right]^{1/2} \quad (4.2)$$

The pulse broadens monotonically with z if  $\beta_2 C > 0$  , however, it goes through initial narrowing when  $\beta_2 C < 0$  .

$$z_{min} = \frac{|C|}{1+C^2} L_D \quad (4.3)$$

And is given by:

$$T(z_{min}) = \frac{T_0}{(1+C^2)^{1/2}} \quad (4.4)$$

In this case the peak power of the pulse is [10].

$$P(z_{min}) = P_0(1 + C^2)^{1/2} \quad (4.5)$$

Initial narrowing of the pulse for the case  $\beta_2 C < 0$  can be explained by noticing that in this case the frequency modulation (or "chirp") is such that the faster ("blue" in the case of anomalous GVD) frequency components are in the trailing edge, and the slower (or "red" in the case of anomalous GVD) in the leading edge of the pulse. As the pulse propagates, the faster components will overtake the slower ones, leading to pulse narrowing. At the same time, the dispersion induced chirp will compensate for the initial one. At  $z = z_{min}$  , full compensation between both will occur. With further propagation, the fast and the slow frequency components will tend to

separate in time from each other and, consequently, pulse broadening will be observed [7].

To demonstrate this, we use a chirped Gaussian pulse with the chirp parameter  $C = 2$  (since  $\beta_2 < 0$  in our case) Figure (4.4).

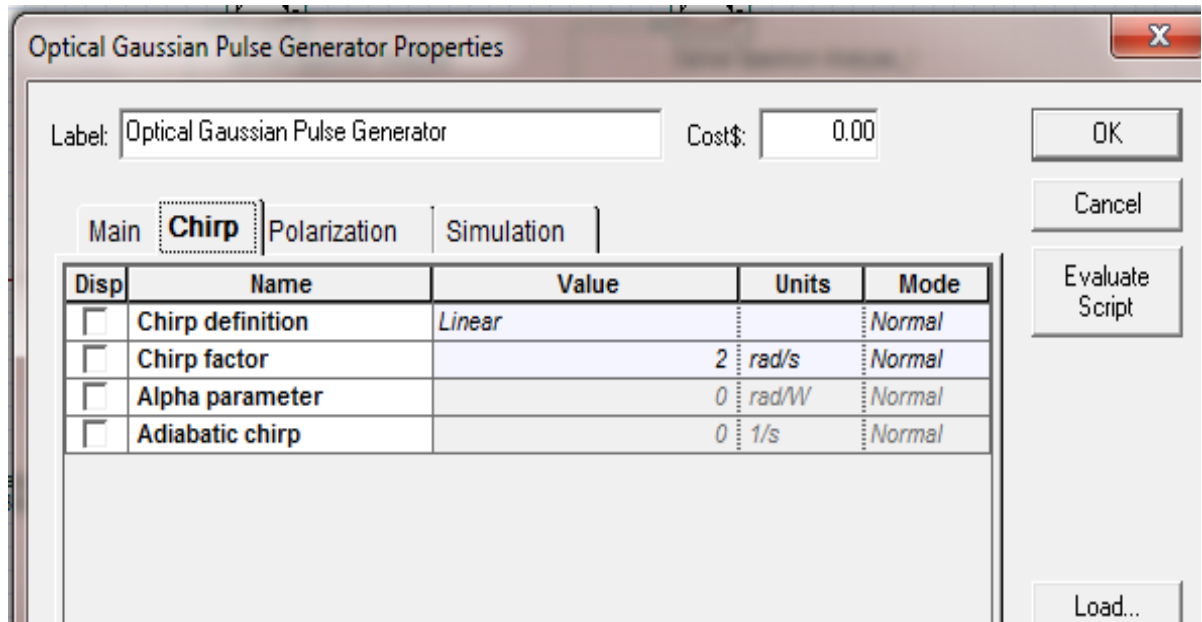

Figure 4.4: Setting the Chirp Parameter to Observe Pulse Compression

Using Eq (4.3) and Eq (4.5); can obtain that:

$$z_{min} = \frac{|C|}{1+C^2} L_D = \frac{2}{5} L_D = 1.125km \quad (4.6)$$

$$P(z_{min}) = P_0(1 + C^2)^{1/2} = \sqrt{5} \approx 2.23 mW \quad (4.7)$$

The length of the fiber changed to 1.125km and calculate the project (the dispersion length is reduced to 1.125 km) .as shown in figure (4.5)



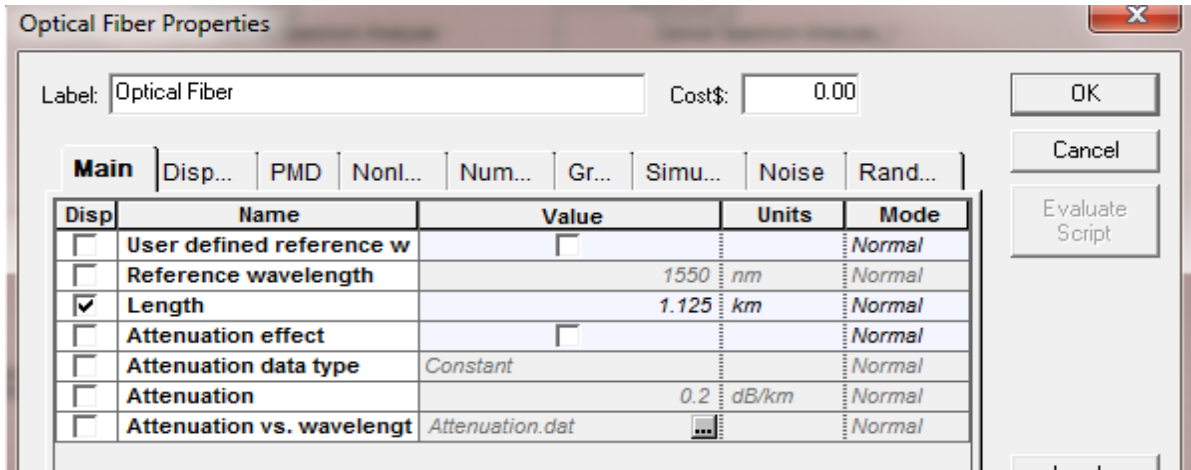
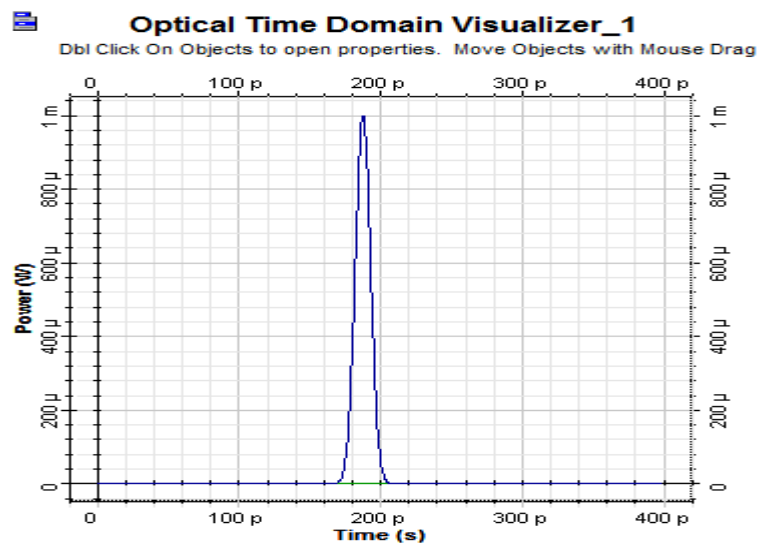
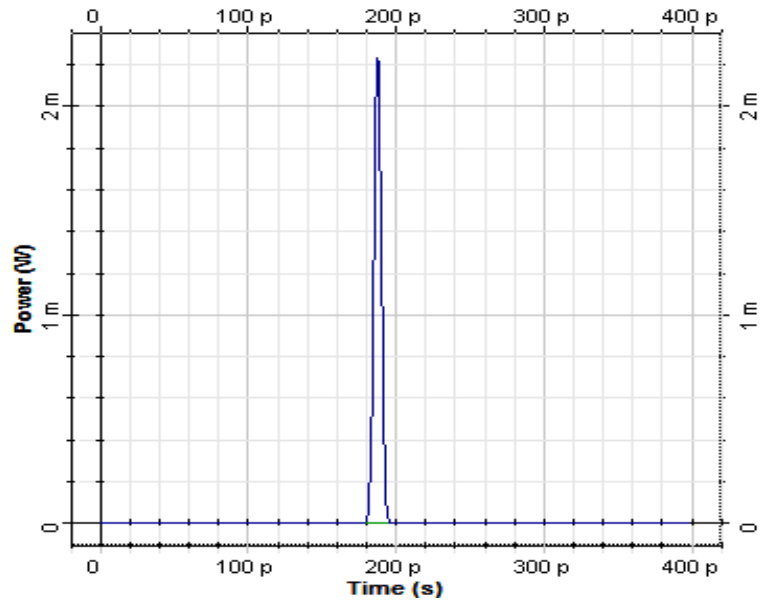

Figure 4.5 optical fiber lengths

In figure 4.6a the signal input in the fiber the value of power 1mw and fig 4.6b the signal output in chirp less. fig 4.6c the signal chirped Gaussian pulse at the input and fig 4.6d the signal optical time Domain visualize chirp (Output) . The results for the output pulse shape and chirp are presented in Figure (4.6). It can be seen that an exact compensation between the dispersion induced and initial chirp occurs, and that the peak power of the pulse is  $\approx 2.23mW$  , as given by Eq (4.5). **Note:** There is exact compensation between the initial and the dispersion-induced chirp.



(a)



(b)



### Optical Time Domain Visualizer\_1

Dbt Click On Objects to open properties. Move Objects with Mouse Drag

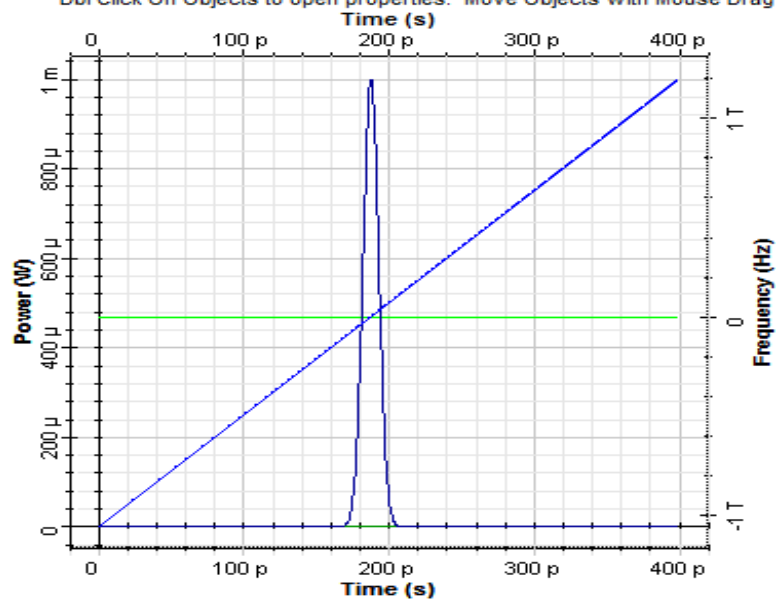

(c)

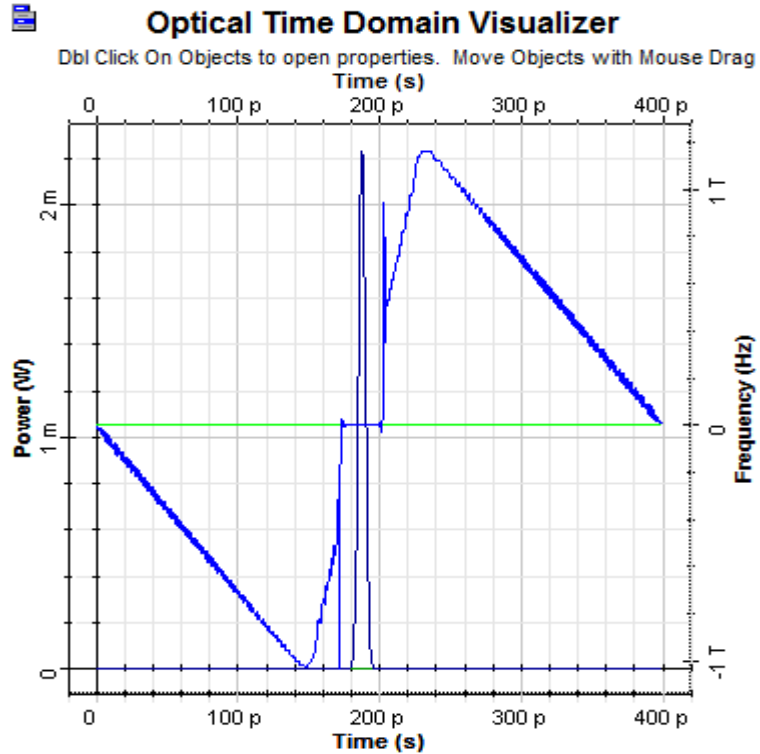

(d)

Figure 4.6: Pulse shape and chirp at  $z=0$  and  $z=z_{\min}$ , (a)Optical Time DomainVisur\_2(Input) , (b) Optical Time Domain (Output).(c) Optical Time Domain Chirp (Input) , (d) Optical Time Domain Chirp (Output) .

## 4.2 Compensation with Ideal Dispersion Component:

Results and discussion the four cases in different lengths of fiber optic.

### 4.2.1 Case 1:- when the optical fiber is 10km dispersion -160ps/nm

The simulation result of the optical fiber in time domain the signal input in fiber the value of power 1mw is shown in figure 4.7a and without using ideal dispersion component in figure 4.7 b in the end of the fiber input signal power decrees to 0.263mw in the value of the power. Figure (4.7) shown the results when the pulse was launched in 10 km in single mode fiber (SMF). As a

result of this propagation, the width of the pulse increases approximately four times.



### Optical Time Domain Visualizer 1

Click On Objects to open properties. Move Objects with Mouse Drag

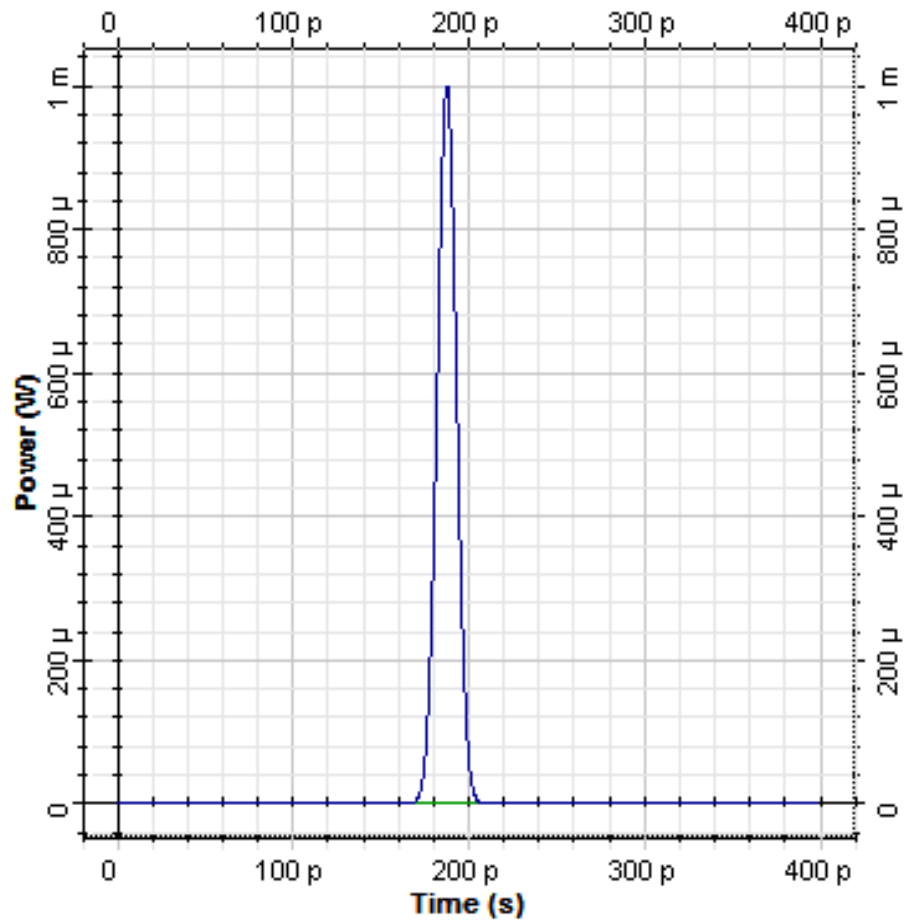

(a)



## Optical Time Domain Visualizer 2

Click On Objects to open properties. Move Objects with Mouse Drag

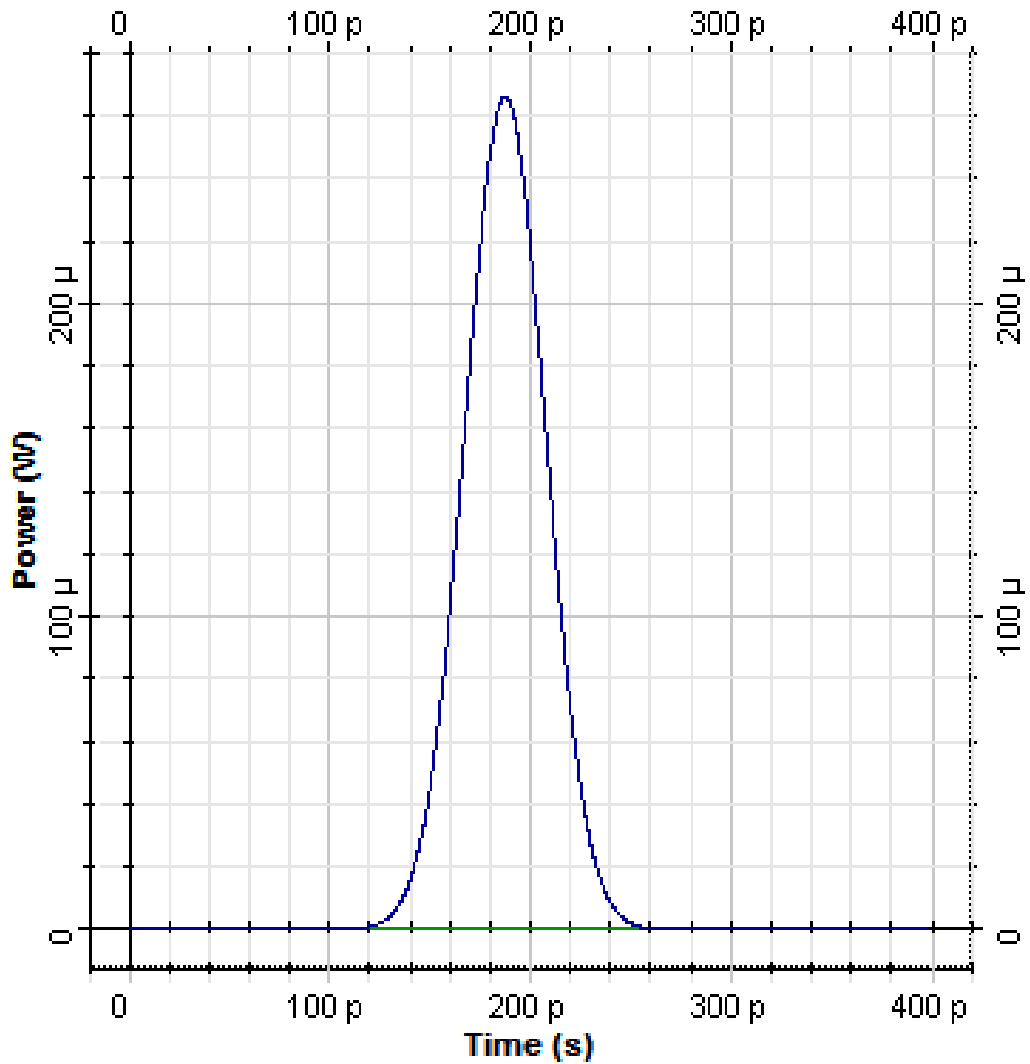

Figure 4.7: Initial Gaussian pulse and Gaussian pulse after 10 km propagation in SMF

(a)Optical Time Domain Visualizer1 (Input) (b)Optical Time Domain  
Visualizer2(Output)

Then if the main tab of the Ideal Dispersion Compensation fiber bragg grating component adjusted at (- 160 ps/nm).the output of the Ideal Dispersion Compensation as showed in Figure (4.8). When comparing the two figure 4.7b&4.8 it is clear that when using the ideal it broadening origin pulse and this can enhance the receive signal is increase the value of the power from 0.263mw to 0.98mw and compensation of the dispersion in the signal about 98% .

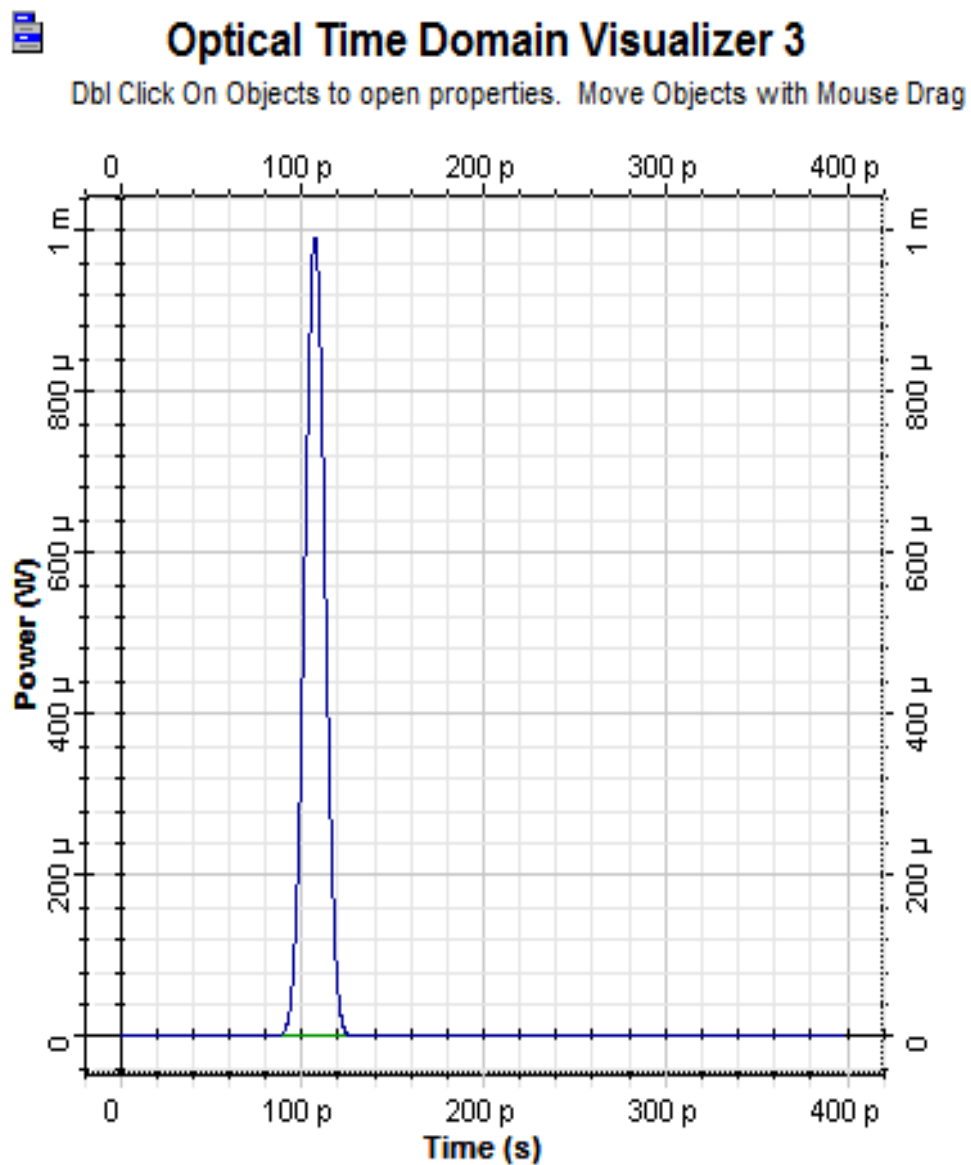
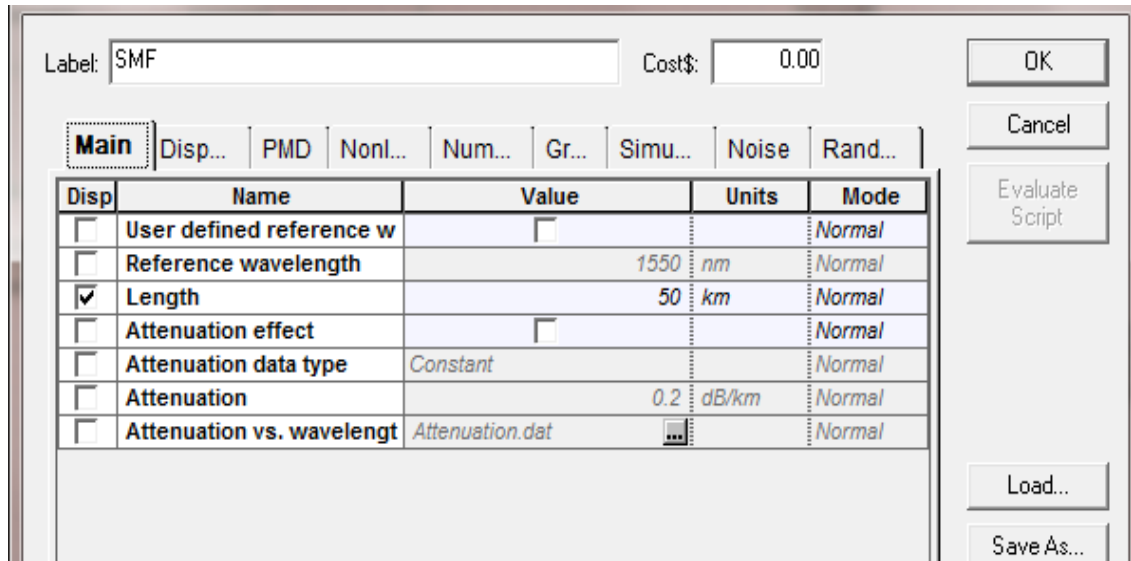

Figure 4.8: Dispersion Compensation Performed with Ideal Dispersion Component.

#### 4.2.2 Case 2:- when the optical fiber is 50km dispersion -800ps/nm

When some parameter is changed as mentioned below and takes other reading the result as show at figure (4.9).

- i. Single mode fiber length = 50 km.
- ii. Dispersion parameter = - 800 ps/nm.



(a)

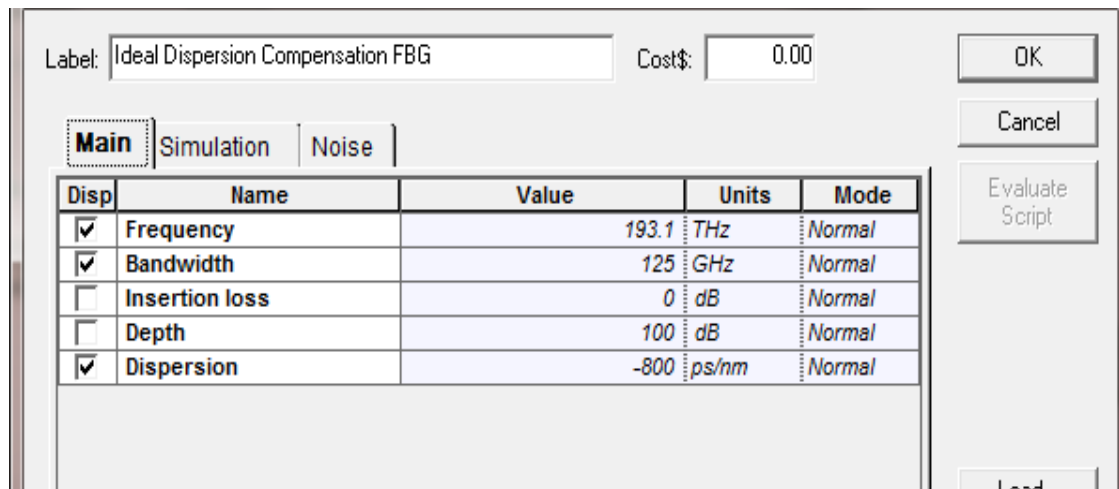

(b)

Figure 4.9: Initial Gaussian Pulse after 50 km Propagation in SMF, (a) Fiber length (b) dispersion

The simulation result of the optical fiber in time domain the signal input in fiber the value of power 1mw is shown in figure 4.10a and without using ideal dispersion component in figure 4.10 b. In the end of the fiber the input signal power decrees to 0.058 mw in the value of the power. Figure (4.10) shown the results when the pulse was launched in 50 km SMF. When comparing the two figure(4.10b&4.10c)it is clear that when using the ideal it broadening origin pulse and this can enhance the receive signal is increase the value of the power from 0.058mw to 0.92mw and compensation the dispersion in the signal about 92% .

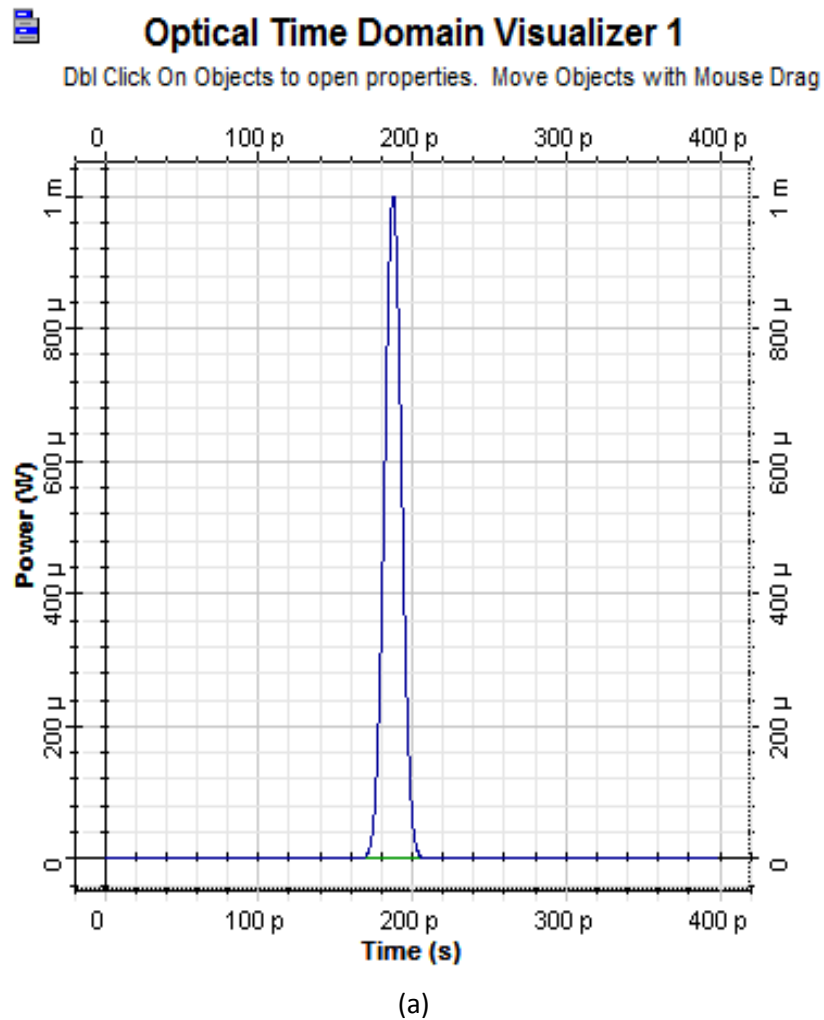



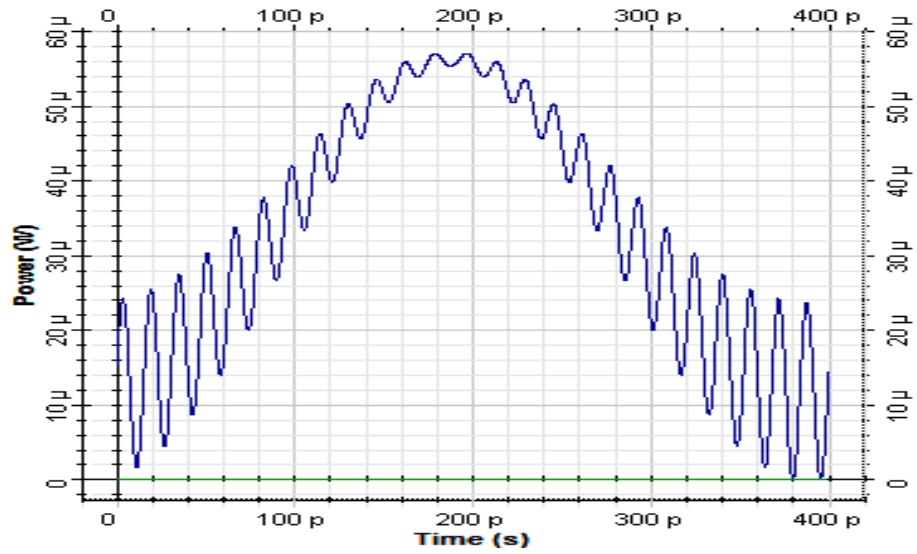

(b)

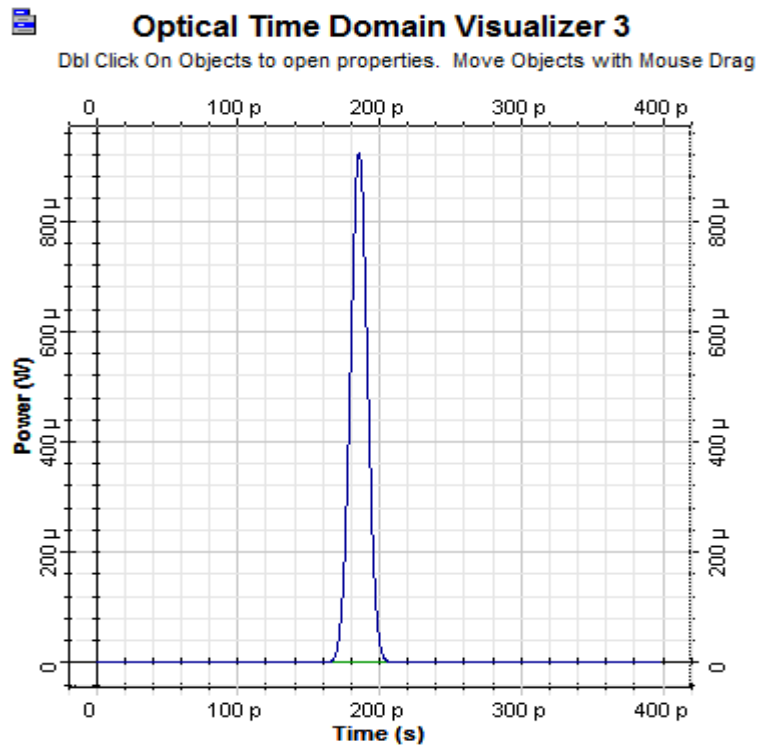

(c)

Figure 4.10: Result of Dispersion Compensation with Ideal Dispersion Component, (a) Optical Time Domain Visualizer1 (Input)(b) Optical Time Domain Visualizer2 (Output)(c) Optical Time Domain Visualizer3 (Output)

### 4.2.3 Case 3:- when the optical fiber is 100km dispersion -1600ps/nm

When some parameter is changed as mentioned below and takes other reading the result as show at figure as (4.11).

- i. Single mode fiber length = 100 km.
- ii. Dispersion parameter = - 1600 ps/nm.

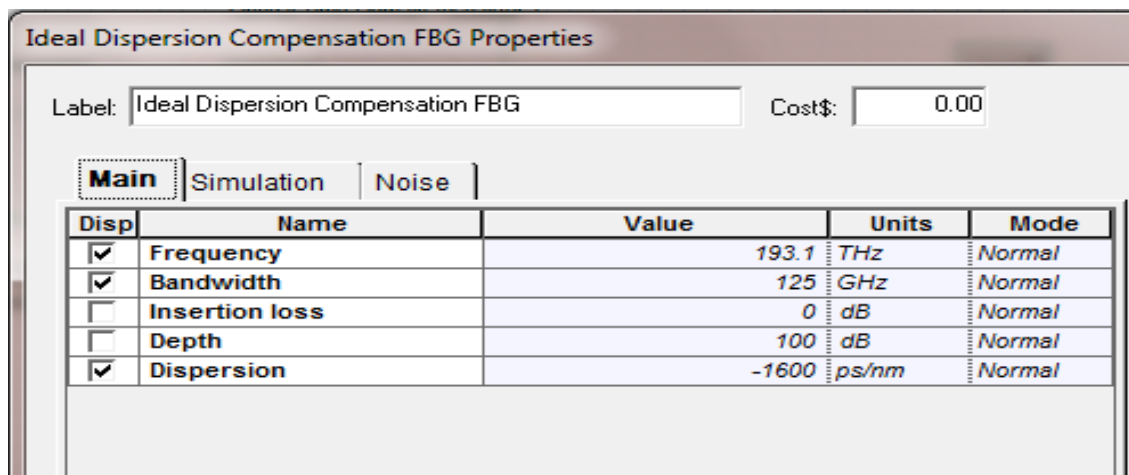
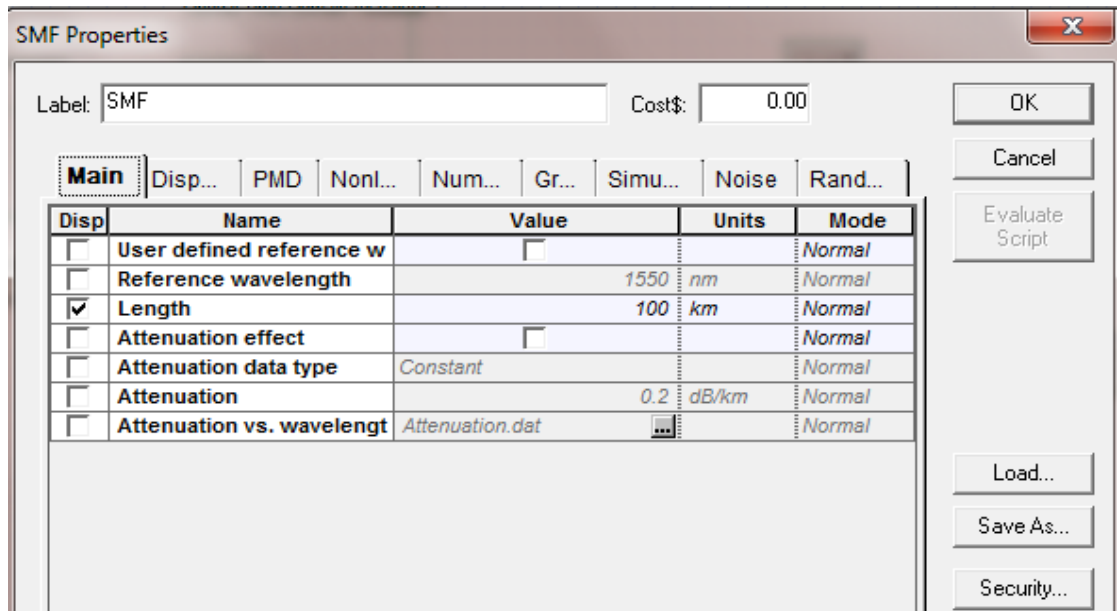
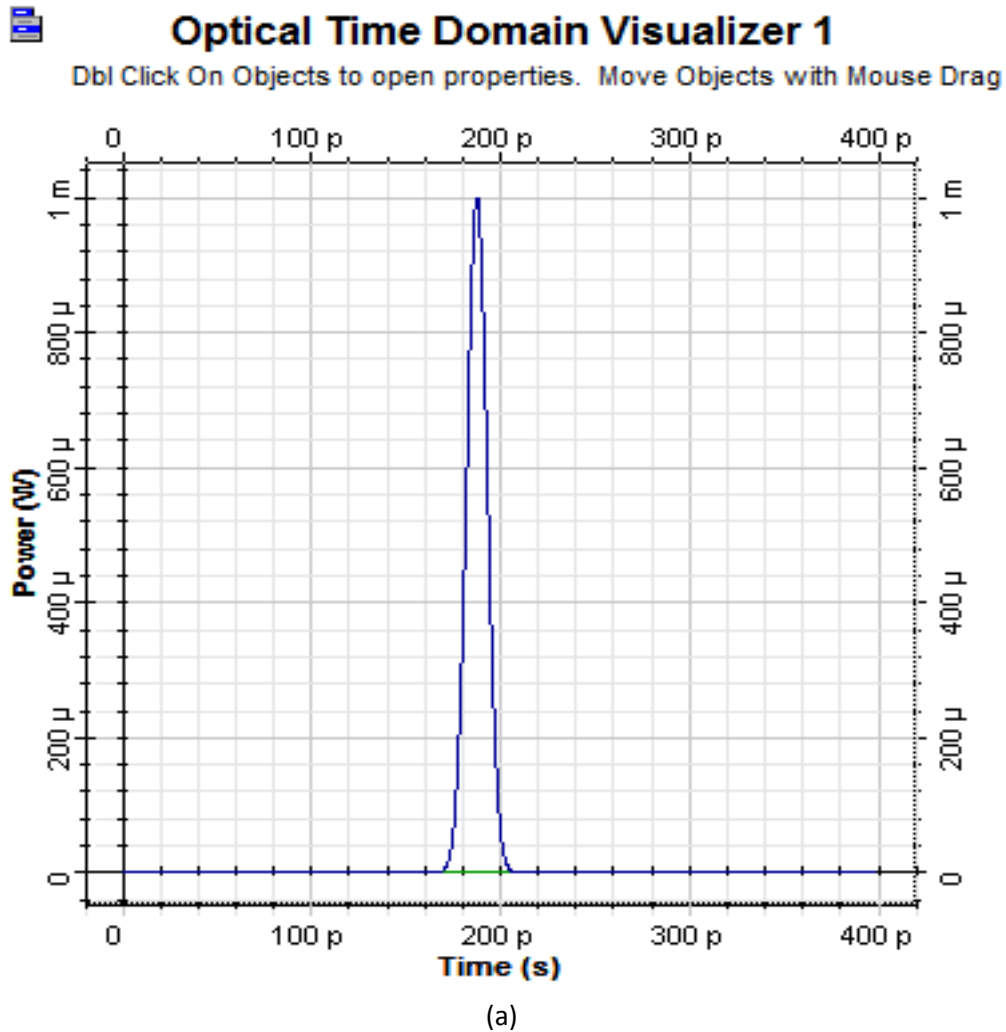
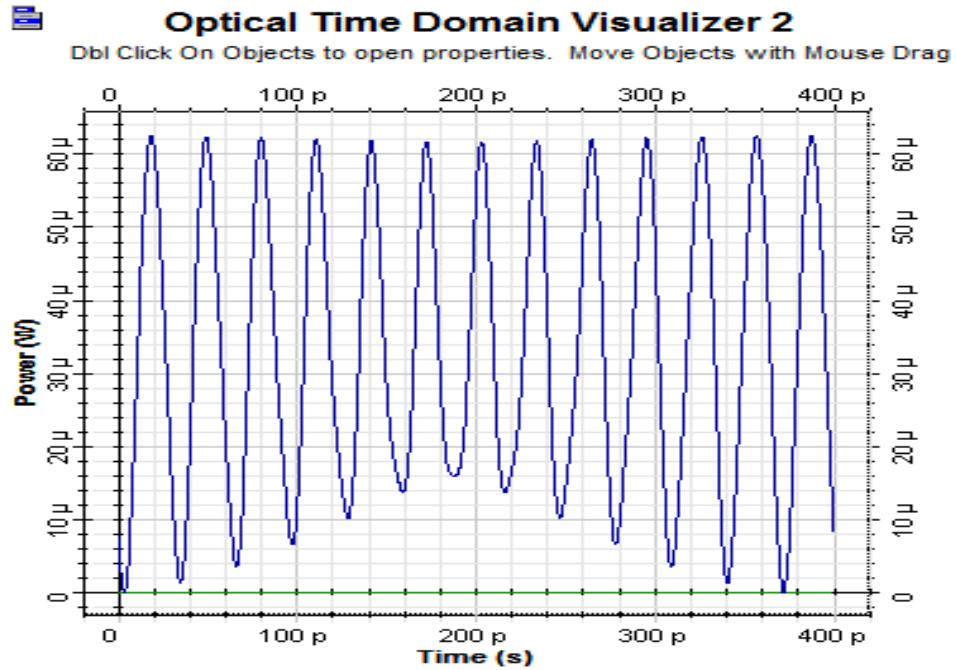

Figure 4.11: Initial Pulse in Gaussian after 100 km Propagation in SMF

The simulation result of the optical fiber in time domain the signal input in fiber the value of power 1mw is shown in figure 4.12a and without using ideal dispersion component in figure 4.12 b. In the end of the fiber the transmit signal is degradation and changed in the value of the power. Figure (4.12) shown the results when the pulse was launched in 100 km SMF. When comparing the two figures (4.12b&4.12c) it is clear that when using the ideal it broadening origin pulse and this can enhance After the Ideal component they receive signal is increase the value of the power from 0.018mw to 0.78mw and compensation the dispersion in the signal about 78%.





(b)

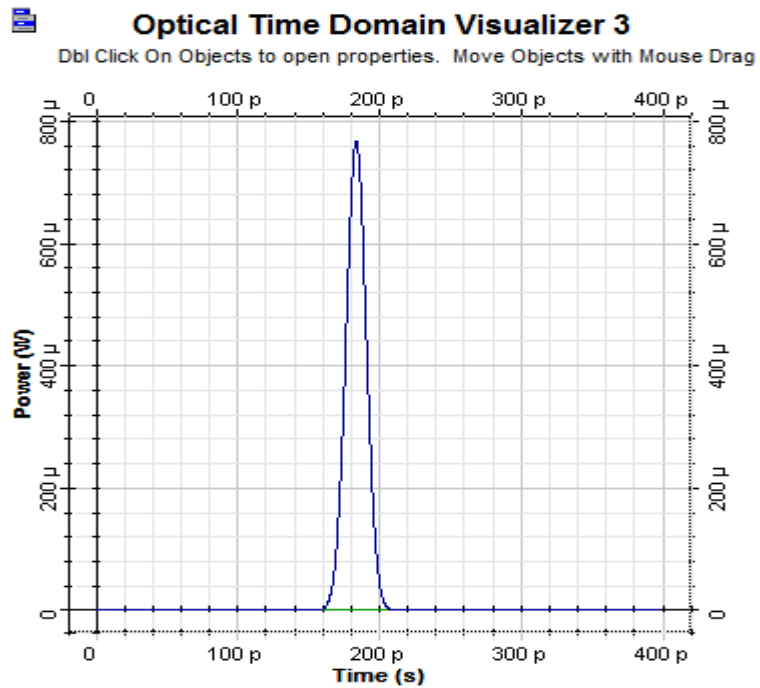

(c)

Figure 4.12: Initial Pulse in Gaussian after 100 km Propagation in SMF.(a) Optical Time Domain Visualizer1 (Input)(b) Optical Time Domain Visualizer2 (Output)(c) Optical Time Domain Visualizer3 (Output)

#### 4.2.4 Case 4:- when the optical fiber is 200km dispersion -3200ps/nm

When some parameter is changed as mentioned below and takes other reading the result as show at figure as (4.13).

- i. Single mode fiber length = 200 km.
- ii. Dispersion parameter = - 3200 ps/nm.

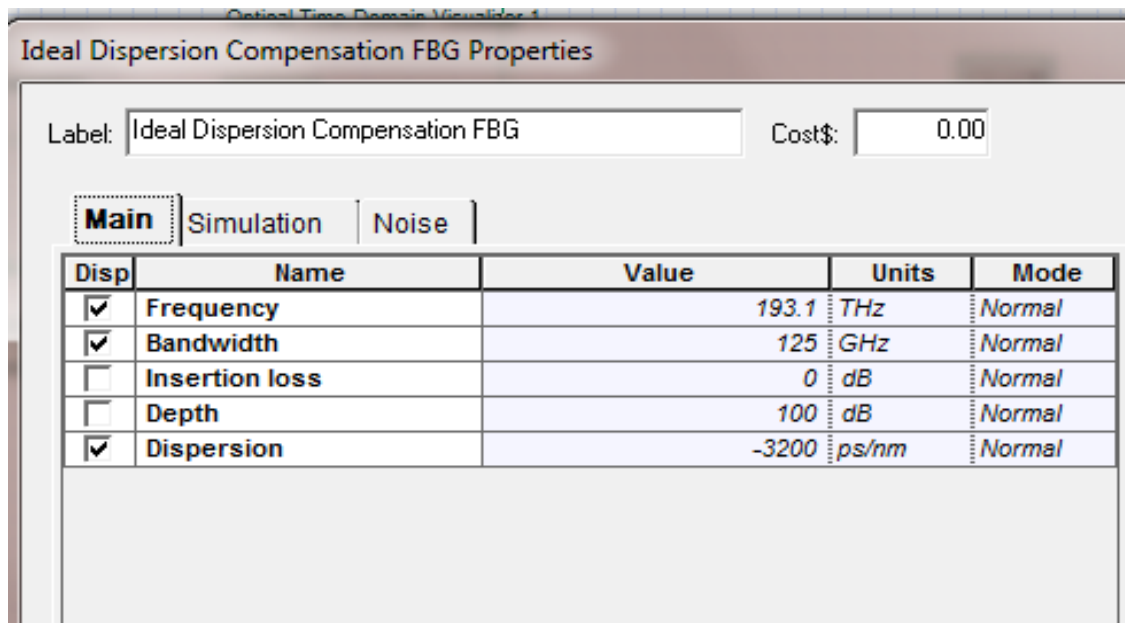
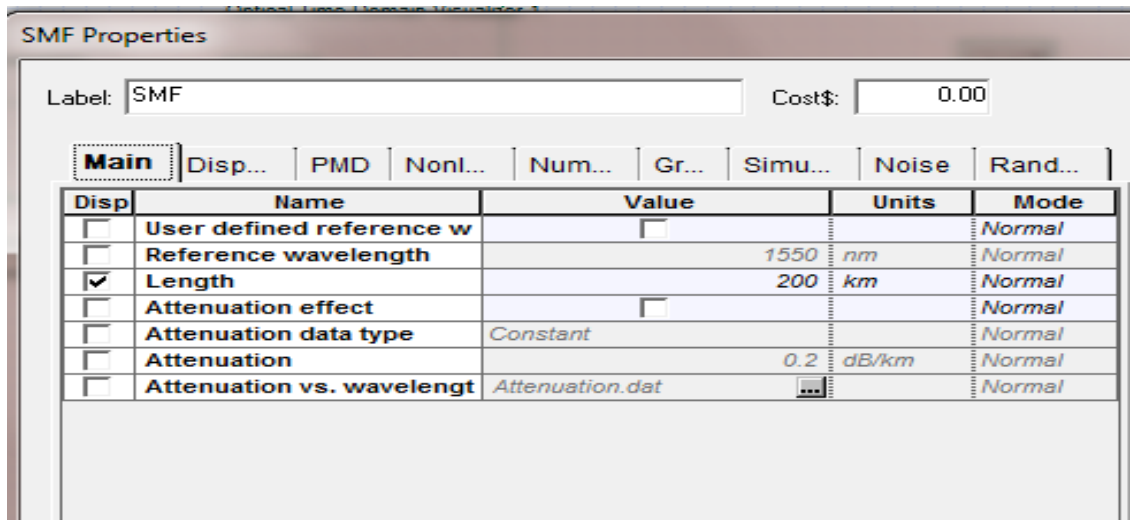
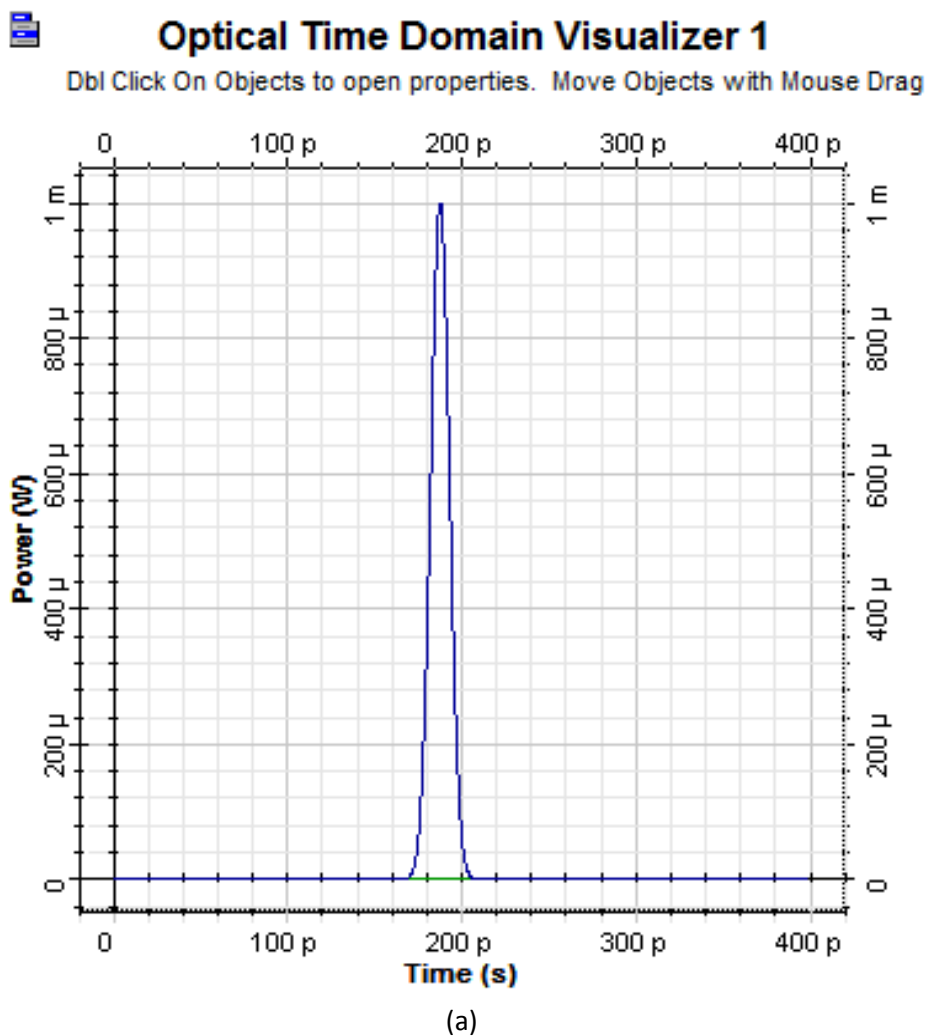
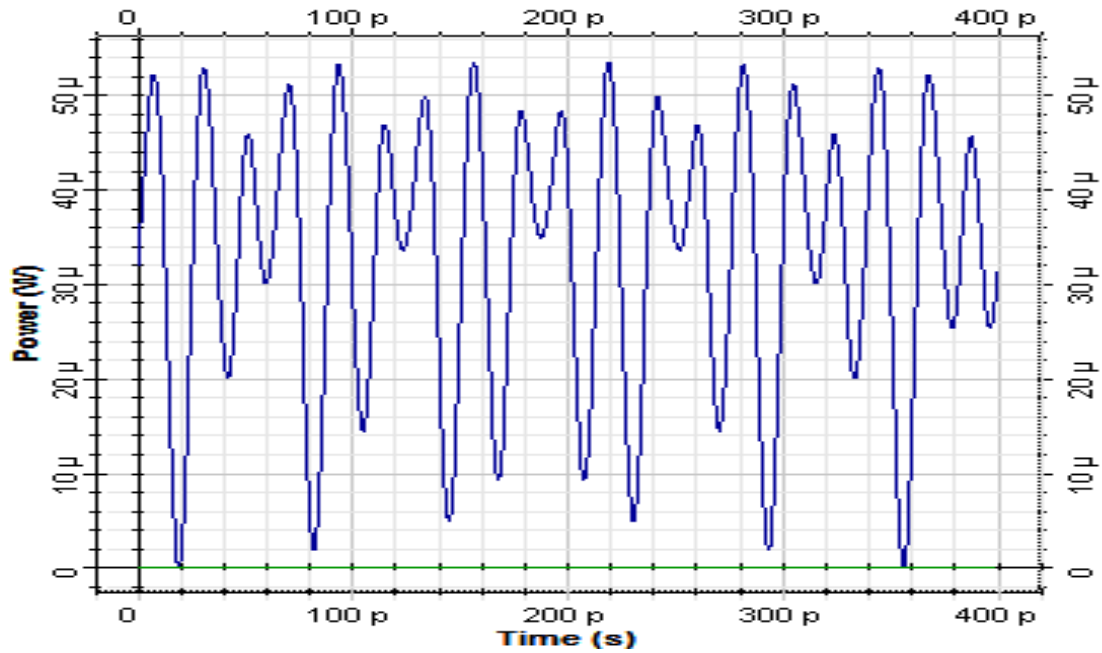

Figure 4.13: Initial Pulse in Gaussian Pulse after 200 km Propagation in SMF

The simulation result of the optical fiber in time domain the signal input in fiber the value of power 1mw is shown in figure 4.14a and without using ideal dispersion component in figure 4.14 b. In the end of the fiber the transmit signal is degradation and changed in the value of the power. Figure (4.14) shown the results when the pulse was launched in 200 km SMF. When comparing the two figures (4.14b), (4.14c) it is clear that when using the ideal it broadening origin pulse and this can enhance After the Ideal component they receive signal is increase the value of the power and compensation the dispersion in the signal about 52%.





(b)

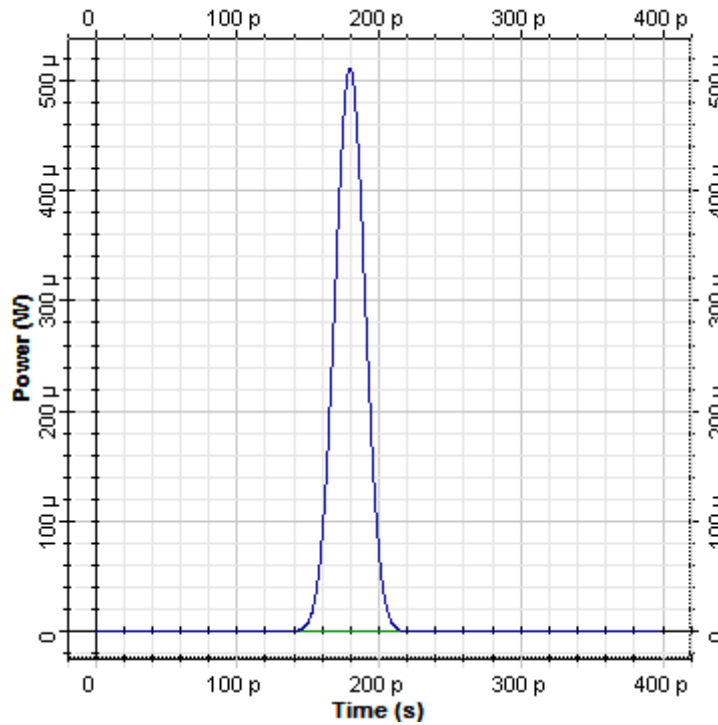

(c)

Figure 4.14 Result of Compensation Performed with Ideal Dispersion Component,  
 (a) Optical Time Domain Visualizer1 (Input)(b) Optical Time Domain Visualizer2  
 (Output)(c) Optical Time Domain Visualizer3 (Output).

# **CHAPTER FIVE**

## **CONCLUSION AND RECOMMENDATION**



## Chapter Five: Conclusion and Recommendation

### 5.1 Conclusion

This section gives a summary of the final research after the Compensation of Fiber Dispersion with Ideal Component .The compensation of dispersion was analyzed using mathematical operations. And designs clarify by simulation using optisystem software. We used different lengths of fiber (10km,50km,100km,200km), By sending signal of 1mw for 10km distance, the result shows that the receive signal without ideal compensation Fiber Bragg is 0.263mw& with ideal compensation Fiber Bragg is 0.98mw also in 50km distance, the result shows that the receive signal without ideal compensation Fiber Bragg is 0.058mw& with ideal compensation Fiber Bragg is 0.92mw,so more in distance 100km, the result shows that the receive signal without ideal compensation Fiber Bragg is 0.018mw& with ideal compensation Fiber Bragg is 0.78mw,In 200km length and when comparing the signal without ideal compensation fiber bragg grating is 0.015mw & with ideal compensation Fiber Bragg is 0.52mw.

And found good consequence they for the compensation of dispersion is verify and have good output result with distances less than 200km.

Expected, an exact compensation of accumulated dispersion was achieved. In conclusion, we have shown in this session how to use an Ideal Dispersion Compensation fiber brag grating component in OptiSystem for dispersion compensation.

## **5.2 Recommendations**

After 200km distance, power signal decrease to small value and after Ideal component the power decrease to half signal power, so I recommend to Developing and enhancement the Ideal component to be able to increase the power to the value that greater than half power signal.

## • References

1. Arora, O. and K.K. Sharma, *A NOVEL APPROACH OF DISPERSION COMPENSATION BASED ON FIBER BRAGG GRATING*. Journal of Information and Operations Management, 2012. **3**(1): p. 46.
2. Kaur, M. and H. Sarangal, *Analysis on Dispersion Compensation with Dispersion Compensation Fiber (DCF)*. SSRG International Journal of Electronics and Communication Engineering (SSRG-IJECE)–volume. **2**.
3. Kaur, M., H. Sarangal, and P. Bagga, *Dispersion compensation with dispersion compensating fibers (DCF)*. International Journal of Advanced Research in Computer and Communication Engineering, 2015. **4**(2): p. 354-6.
4. Kahlon, N. and G. Kaur, *Various dispersion compensation techniques for optical system: a survey*. open journal of communications and software, 2014. **1**(1): p. 64-73.
5. Sethi, R. and A. GOEL, *DISPERSION COMPENSATION IN OPTICAL COMMUNICATION SYSTEM BY EMPLOYING 16-QAM MODULATION USING OFDM*. IMPACT: International Journal of Research in Engineering & Technology, 2015. **3**(2): p. 47-64.
6. Mohan, A., et al. *Compensation of dispersion in 5 Gbps WDM system by using DCF*. in *Green Computing Communication and Electrical Engineering (ICGCCEE), 2014 International Conference on*. 2014. IEEE.
7. Kadangote, J.V., N. Johney, and A.R. Somasekharan, *Comparison of Different Chromatic Dispersion Compensation Techniques in Radio*

- over Fiber System*. American Journal of Optics and Photonics, 2015. **3**(2): p. 24-29.
8. Singh, P., *Dispersion Compensation in an Optical Fiber by Using Chirp Gratings*. International Journal of Research in Engineering and Technology, 2014. **3**(7): p. 506-508.
  9. Udayakumar, R., V. Khanaa, and T. Saravanan, *Chromatic dispersion compensation in optical fiber communication system and its simulation*. Indian Journal of Science and Technology, 2013. **6**(6): p. 4762-4766.
  10. Arora, O. and D.A.K. Garg, *impact of fiber Bragg grating as dispersion compensator on the receiver characteristics*. Global Journal of researches in engineering Electrical and electronics engineering, 2011. **11**(7).
  11. Kaur, M. and H. Sarangal, *Performance comparison of Pre-, Post-and Symmetrical-dispersion compensation techniques using DCF on 40Gbps WDM system*. International Journal of Advanced Research in Electronics and Communication Engineering (IJARECE), 2015. **4**(3).
  12. Tomkos, I., et al., *10-Gb/s transmission of 1.55- $\mu$ m directly modulated signal over 100 km of negative dispersion fiber*. IEEE Photonics Technology Letters, 2001. **13**(7): p. 735-737.
  13. Shan, N. and A. Asha, *Simulation and Analysis of Optical WDM System Using FBG as Dispersion Compensator*. International Journal of Engineering Research and General Science, 2015. **3**(2).
  14. Paul, L. and H. Sarangal, *Performance Comparison of Different Fiber Standards on 80 Gbps OTDM System*. 2016.
  15. O'Shea, D. *Group velocity dispersion using commercial optical design programs*. in *Lasers and Electro-Optics, 2002. CLEO'02. Technical Digest. Summaries of Papers Presented at the*. 2002. IEEE.

16. Mani, B., K. Chitra, and A. Sivasubramanian, *Effect of Group Velocity Dispersion (GVD) with and without initial Gaussian Chirp in Enhanced-Large Effective Area Fiber (E-LEAF)*. pulse. **8**: p. 9.
17. Mishra, R., N. Shukla, and C. Dwivedi, *A Comparative Performance Analysis of Optical Fibre System with FBG Compensated SMF for High Data Rate*. Imperial Journal of Interdisciplinary Research, 2016. **2**(7).
18. Hu, B.-n., et al. *Analysis on Dispersion Compensation with DCF based on Optisystem*. in *Industrial and Information Systems (IIS), 2010 2nd International Conference on*. 2010. IEEE.
19. Singh, M. and B. Rajveer, *Analysis of Dispersion Compensation using Fiber Bragg Grating in Optical Fiber Communication System*. International journal of computer applications, 2015. **126**(5).
20. Lidon, M.S., *Digital Pre-compensation of Chromatic Dispersion in QPSK high speed telecom systems*. 2011.
21. Li, S.-Y., et al., *Influence of group-velocity-dispersion effects on the propagation of femtosecond laser pulses in air at different pressures*. Physical Review A, 2014. **89**(2): p. 023809.
22. Kumar, K., et al., *Performance analysis of dispersion compensation using Fiber Bragg Grating (FBG) in optical communication*. international journal of current engineering and technology, 2014. **4**(3): p. 1527-1531.
23. Patel, M.G. and S. Khant, *Soliton Transmission in fiber optics for long distance communication*. International Journal of Advanced Research in Electrical, Electronics and Instrumentation Engineering, 2014. **3**(2).



---