



### The Conflict that Manipulates Teaching Manual Linear Perspective

Omer Elamin Ahmed Abdallah<sup>1</sup>, SulimanYahya<sup>2</sup>, Alfatih FadoL Bushara, Mobarak Dirar<sup>3</sup>

<sup>1,2,3</sup>University of Sudan College of Graduate Studies

#### ABSTRACT :

Linear perspective is a knowledge that had spread through the European world of art and design since the 15<sup>th</sup> century up to the last decades of the 20<sup>th</sup> century. It was concerned directly with the growth of scientific mind on that fertile soil of art and design's mind of that time. Linear perspective had enabled artist and designers to practice depth and represent the third dimension on their landscape painting, design and architectural presentation.

Despite perspective had spent a long time span to occur, but another long time span had followed its appearance, particularly in the educational environment that followed its experimental attitude. For perspective had lived within the limitation of the experimental world, without earning its theoretical side that covers its scientific situation.

This scientific living problem of linear perspective can be concluded in whether could it be treated within the limits of its geometric roots that the artists and designers of the Italian Renaissance had achieved, or put it as its phenomenological existence states that it have to be a visual phenomenon.

So, due to that, the living situation of linear perspective is living a conflict that needs to yield to investigation that combines its historical analytical research with the research field of ophthalmology and optics along with the research of linear drawing and architectural presentation so as to complete its scientific form theoretically and practically.

#### المستخلص:

علم المنظور والذي كانت بداية ظهوره في منتصف القرن الخامس عشر الميلادي في مدينة البندقية الإيطالية، هو الطريقة المحكمة التي يتبعها التشكيليون و المصممون المعماريون لانجاز الرسومات الخطية الأولية والنهائية لمصممااتهم من صور و مناظير معمارية. وقد ساد هذا الأسلوب من الرسم الخطي المنظوري منذ ذلك التاريخ حتى الربع قبل الأخير من القرن العشرين.

و قد بقت هذه الممارسة التشكيلية في حاضنة التاريخ التجريبي التشكيلي لأكثر من أربعين قرناً - أي منذ البدايات التاريخية التجريبية للرسم والتصوير منذ 4000 عام قبل الميلاد في مصر القديمة حتى أوان ظهورها في القرن الخامس عشر الميلادي - كي يتمكن التشكيليون والمصممون المعماريون من امتلاك حرفيتها و استهلال العمل بها. ويبدو كذلك أنها بقيت خمسة عشر قرناً آخراً من التجريب ظلت فيه هذه الممارسة التشكيلية كظاهرة تجريبية هندسية لم تتمكن من تخطى حدود تجريبيتها الهندسية لإكمال مكوناتها العلمية النظري، بوصفها ظاهرة بصرية قبل أن تتمظهر في أي تجريب هندسي. لذلك فقد ظلت ظاهرة التلاشي البصري غير مسبور غورها البصري الذي لم يشكل أمر فحصه هماً تشكلياً ما دام التجريب الهندسي يأتي بأكمله. في حين لم تتمثل ظاهرة التلاشي البصري في بعدها التصويري كتحدٍ علمية أمام علماء البصريات الإحيائي ( الفيسيولوجي ) و الفيزيائي. لذا فقد ظلت ظاهرة التلاشي البصري التصويري كما لم يمارس عليه ما يستحقه من البحث العلمي كي يتم التمكن من اكمال هيئته العلمية النظرية والعملية.



ورغم ان ممارسة رسم المنظور الخطي هو ممارسة تقنية، إلا أن قصور مفاهيمها العلمية كظاهرة بصرية لم تماس خيال أبطال معاركها، فلم يشغلوا أنفسهم بالكشف عن ظاهرة البعد الثالث والعمق في مصوراتهم كالمصورين والمصممين المعماريين. لذا فقد كان أول من أثارها كإشكالية هم أساتذة تاريخ الفنون الأوربيين مثل ارنست كومبرج و مارتن كامب

ولما كانت ظاهرة علمنة التجريب الإنساني على عمومها هي اختصاص لا بد من وجود من يتصدى له، فالتشكيليون والمصممون المعماريون بمعاونة علماء البصريات بشقيها الإحيائي والفيزيائي، فهم مكلفون تكليفاً مباشراً لأجل القيام بسبر غور هذه الظاهرة، ومن ثم إصلاح طرق تدريسها وطرق التزويد المعلوماتي بأصولها العلمية. لذا فقد جاء مقترحي بإجراء دراسة متعددة التخصصات لأجل إكمال هذه المهمة.

و لا بد بالطبع أن تستند هذه الدراسة متعددة التخصصات لأكثر من وسيلة أو آلية منهجية لإجراء فحوصاتها البحثية التي ستجيب عن مسألتها البحثية المتعددة تعدد الحقول التي ستتطرق لدراستها. لذلك فقد جاء مقترح استعمال منهجية التحليل التجريبي لسبر غور ما يتصل بشقي علم البصريات ( الفسيولوجي و الفيزيائي)، على أن يسير هذا الخيار المنهجي مع منهج الوصفية التاريخية لفحص ما يتصل بالممارسة التصميمية التشكيلية على تعدد تخصصاتها.

**كلمات مفتاحية :** علم المنظور الخطي، مناظير معمارية، ظاهرة تجريبية، التلاشي البصري

## INTRODUCTION :

Why do we see objects vanish in vanishing points on the horizon? If we know the fact that our visual rays formulate a pyramid that starts from its base in front of our eyes and extends to a point on the vanishing point on the horizon, how can this horizon then take the shape of a line? And how and why does this horizon line be the border where the sky meets the ground level? If we know that the vanishing and the horizon line phenomena are just illusions that do not really exist what do eyes do to formulate these optical illusions?

These are some of the why-of-vision questions which were asked within the study of perspective and persisted for more than five hundred years, since perspective knowledge was established in the fifteenth century, without answers

### Problem Statement.

Actually, perspective was not just an initiation of knowledge that helped architects and painters to

practice depth and forms in drawings and present vanishing attitude of figures, but a revolutionary experimental movement of the scientific mind which was lead by the explorers of the third dimension, to explore the practice of descriptive geometry and projective geometry. Despite all of these achievements, perspective did not cross the borders of knowledge and entered the world of science, because of some scientific complexities and mysteries that surround its inventors' experimental attitude. This situation may stand as a reason of its lack of theoretical explanation and its inability to face inquiries like what we asked above.

Anyway, whatever might it acts theoretically or practically, it was clear that the two fields, perspective geometric solutions and visual observation of landscapes, were not working cooperatively, but performing contradictory bases, then a scientific conflict. The reason of this scientific conflict was because of the



geometric formula of linear perspective bases had been built on the concepts of the Euclidian geometry and the Euclidian theory of light transformation, which were out of date scientifically.

Therefore, the geometric solutions of the Renaissance Masters might be accepted as an achievement done due to the scientific mentality of their time. But it would not be the same to nowadays mentality. Because it will not be accepted since the time that Alhazen had corrected the theory of light transformation, and changed the older theory about the function of the eye that became a light absorbent tool not a producer of visual rays as it was believed in the Euclidian theory of light transformation.

Consequently teaching linear perspective in its geometric form has become a complicated job, not easily explained and educated. This fact in particular caused a big turn over against the teaching process of geometric linear perspective which was supposed to be done and practiced manually. The substitute to that was a new trend that uses computer based process as a new tool. In fact it easier for designer to use the computer based tool, because it gives a readymade landscape that saves time and effort of the designer. But for students it differs so much. Because they are still in need of a tool that emphasizes their designing abilities. As a result, students are actually in need of the manual process which they miss because they were taught only the new computer based techniques. Thereafter, missing the tool that helps in formulating designing skills was not the sole problem we should face, but that is only the tip of the iceberg. We are faced nowadays by the problem of loosing skilful teachers, lecturers and supervisors who can teach, lecture or lead research on solving the scientific problems of this significant designing tool.

### Methodology of the Research Study

The general appearance of this research study should have to cross the borders between the scientific disciplines and take the interdisciplinary method that combines three main research areas which are art, ophthalmology and optics to face the research problem. The main purpose of this plan is to push the whole case of perspective to yield to research in two methodological tracks:

- 1/ the empirical science investigational and analytical method as track one.
- 2/ the library based historical descriptive analytical method as track two.

We use two tracks of research methodology due to the fact that the last word of this visual phenomenon cannot be understood only through drawing, painting, and architectural presentation, but there are other fields of study; each field deals partially with the side which relates to it. The first track research will cover Painting and architectural presentation studios to be done subsequently with ophthalmology and optics experimental laboratories. Both of the two tracks are supposed to cover the grammar of vision and the geometry of picture transformation that relates to the vanishing attitude in landscapes. Then follow the analytical deconstruction of the historical descriptive method as research tool on the historical experiments, practice, terminology and the text references of the art and design section

### The Objectives of the Research Study

While this study should cover the theoretical part of the experimental attitude of linear perspective, it should have to maintain the educational form of this important educational and experimental tool.

We recognized above that the educational form of perspective had changed its identity from manual techniques of expressions to a



readymade and previously arranged computer based tool. Then we decided that students had missed an important learning tool that emphasizes their design skills. So this research study could be taken as a part of the think-tank that preserve or maintain our educational system. Objectively it would be done in the right time before losing the track to its teaching environment after losing its skilled teachers and research supervisors .

#### **The literature Review:**

It appears that the scientific conflict faces those who want to pose any theoretical face to linear perspective if they tried to do that while they depend on its Renaissance geometric formula. The following texts were supposed to reflect the living scientific references that explain perspective, but unfortunately they were instead replicating the conflict. These texts are:

1: The first text is taken from a short review by Dr. Kim H. Veltman, the Scientific Director of the Maastricht McLuhan Institute. He wrote a very short but effective critique of Dr. S. Edgerton, who contributed a book on perspective titled (The Renaissance Rediscovery of Linear Perspective.)<sup>1</sup> S. Edgerton Jr, (July 1977), The Renaissance Rediscovery of Linear Perspective, The Art Bulletin, New York, Vol. 59, No. 2, (pp.281-282. The importance of DrVeltman's short quotation is that he put his finger on the spot of the confusion. He stated: "The reason for Edgerton's ongoing confusion is quite obvious. He does not distinguish clearly between the objective relationship that linear perspective establishes with the measured world and the subjective interpretations of visual perception-let alone make more subtle distinctions, as has Gombrich, between

perspective relating to the 'what' but not the 'how' of vision."

2: The second text is taken from Professor Martin Kemp's book (The Science of Art; Optical Themes in Western Art from Brunelleschi to Seurat.) Martin Kemp, (1990) "The Science of Art" Yale University Press, New Haven and London, , P334

It appears that Professor Kemp was aware enough of the conflict about the how or the what of vision. His awareness however, did not lead him to maintain its disorder, but he just wrote: "The first and most historically orthodox of these questions concerns the explanations as to why there should be so much shared ground between visual art and optical science in this particular period. In other words, what explanatory causes can be assembled? The second question concerns the status of the optical 'truth' with which our predominantly naturalist art has been concerned. On the surface, this question is not historical, but cannot be disentangled from interpretation of the history, since our view of the visual status of the techniques will radically affect where we look for our historical explanation. If, for instance, we believe that orthodox perspective is not more or less than an artificial convention based on a manner of 'seeing' peculiar to a particular period, we will formulate a different kind of explanatory model than if we believe that it stands in some privileged relationship how the world is 'really seen' and that it was, like the law of gravitation, waiting to be discovered."

3: The third text refers to Professor Joseph W. Dauben of Columbia University, USA, who wrote a book and added an educational film explaining how mathematics was the scientific roots of linear perspective/ Joseph W. Dauben, The Art of Renaissance Science ([www.crs4.it/Ars/arshtml/arch1.html](http://www.crs4.it/Ars/arshtml/arch1.html)) He passed



on the same confusion that existed in the minds of Renaissance masters instead of explaining the mathematical roots of perspective. He said: “We don't know how far Brunelleschi intellectualized his system in mathematical terms, but it was not long before someone did. In 1435, Leon Battista Alberti, another architect, published a treatise on perspective (Della Pitture) in 1435. Once Alberti's treatise was **published, knowledge** of perspective no longer had to be passed on by word of mouth.” But when we study Alberti's treatise, we can actually discover a scientific simplicity leading us to assume that Prof. Dauben did not actually study or even understand Alberti's treatise when he said: “Once Alberti's treatise was published, knowledge of perspective no longer had to be passed on by word of mouth.” Or when he said: “For some it became a matter of consuming artistic, even philosophical interest” because Alberti did not write in his treatise any explanations theoretically or practically concerning perspective, except a little quotation about “the far point” which had been referred to after as “the vanishing point.” Actually when studying Professor Dauban's explanations, we recognize that he did not realize that Brunelleschi or Alberti were not conscious of the concept of visual vanishing so as to state the rules of perspective. If not so, Professor Dauban should have been aware of a historical understanding of the new visual vanishing phenomenon or even the knowledge of drawing three dimensional or performing depth in pictures

4: The fourth text was taken from a mathematics book titled (Introduction to Projective Geometry) by Professor C. R. Waylie, the head of the Mathematics Department at the University of Utah, USA. ) C. R. Wayliejr Introduction to Projective Geometry McGraw

hill book company , New York He was not only trying to criticize the geometric form of perspective, but he was actually trying to give reasons why mathematicians do not think the same way about the geometric suggestions of perspective. Indirectly he stated that the geometric suggestions made for perspective were not real; or in other words, they are not natural. He stated, "Presumably, the scene in which an artist is interested always lies on the opposite side of the picture plane from the viewing point. Hence, the picture itself always lies in the half of the picture plane which is on the same side of the object plane as the viewing point. However, in the mathematics discussion of perspective such restrictions are unnecessary and unnatural, and shall assume that our transformations extend over the entire object and image planes.”

5. The fifth text seems to be touching other sides of linear perspective. The Professor of architecture of the University of Dundee Dr. Lornes Holms discussed the dialogue between the subjectivity of the psychoanalysis and the objectivity of architecture. He researched the relation between space and psyche. He suggested that Brunelleschi's invention is a compared conception to psychoanalysis done by Lacan. He also touched the living scientific problem when he posted a question asking: ‘seeing through what

<sup>1</sup> )Lorens Holm, “Brunelleschi, Lacan, Le Corbusier” Rutledge Taylor &Francis Group, London and New York, **page 37. 2010, page 37.**

so as to investigate Albrecht Durer's quotation: “Perspective is a Latin word which means ‘seeing through.’ Ibid, page 37 Then he continued in exploring different answers of different way of seeing and thinking when he said: “Theoreticians and practitioners of

perspective like Alberti or Leonardo said like seeing through window. Alberti first theorized the perspective image as a planar cross section through the pyramid of vision. A physiologist might reply: seeing through the eye. S/he is attentive to the way optics and biology intersect at the cornea, and probably is not worried about the fact that the retina images is an image to everyone except the person upon whose retina it is projected. And those of us who are attentive to the conundrum of subjectivity might say: seeing through the subject, an answer that is both more or less obvious, more or less plagued by problems of self-reference. Ibid page 37

6. The painter David Hockney and the professor of architecture of University College of London Professor Philip Steadman addressed neither the geometric linear perspective nor the objectivity of its missed visual perception. But both of them being fully aware of styles and skills of drawing and painting, they put what was thought to be mathematical experiments of the Renaissance masters to careful studies and investigation. These investigations led them to state an amazing result, that the Renaissance masters were drafting their drawings by using a pinhole camera. This statement unconstrained the fact that art historians' contribution assumed to be misleading the point, caused by their judgment to the case from outside its technical field. More of that these two scholars had opened the door wide to huge size assumptions that the linear perspective:

- a. as some mathematician had stated, Ibid, page 37. has nothing to do with the field of mathematics' studies.
- b. is not an invention but a randomly gained knowledge.
- c. is not a projection which was thought to be a concern of visual rays while it is not, but a

practitioner mentality's terminology that refer to the camera obscura.

#### **Questions and Hypothesis of the research** **A/ The main question of the research study:**

Is it true that a drawn on normal paper size landscapes following the rules of the living geometric linear perspective can neither represent the real scenery of this landscape, nor provide the real grammar of how its figures vanish?

#### **B/ subsequent questions:**

If the answer is no, another questions need to be answered within this study. These questions as follows:

1. Why and how do objects vanish visually?
2. As a visual phenomenon, what is the horizon? And how is it geometrically formed in a line? And why do objects vanish on it?
3. What is the eye level? Is it usually horizontal or it can be vertical? Is it one or are there many others?
4. Is there any calculation showing how some objects resist vanishing and appear faintly beyond the horizon in sky blue such as mountains, and what objects vanish before or in the horizon line?

#### **C/ Hypothesis of the research**

For the research questions were asked above, there are assumed facts that represent their answer. These assumptions will be considered as hypothesis of this research study. They are as follows:

- 1/ the geometric linear perspective living practice are quite deferent from the actual geometry of vision.
- 2/ Seen objects in landscapes vanish around the horizon due to changes of angles of the pyramid of vision that take place under the effect of two upside down turns within the transformation



process of the visual rays of landscapes into the eye,

3/ the Horizon line and its duplicate, the eye level, are shaped in a line, because they appear as a track of countless vanishing points caused by the countless pyramids of vision that enable landscapes to be seen.

4/ landscapes are illusion caused by one based countless pyramids of vision. Part of them begins moving out of the seen landscape, the others from the eye. All of them formulate the geometry of the visual rays.

#### Discussion

Perspective, as an invented knowledge, helped painters and architects to draw their landscapes and to be the leaders of one of the main cultural trends of the twentieth century named 'visual perception.' Despite that, perspective did not earn the capability of crossing the borders of the field of knowledge to earn a seat in the field of science, and be able to answer questions, such as what were asked above, about its identity. One of the main reasons for this shortage is its lack of roots. Art historians assume that perspective was born within the family of mathematics, but mathematic professors neglect this assumption saying that perspective has nothing to do with mathematics, because it has no law or theory or even an equation. They support their argument by saying that if perspective is a branch of mathematics, it should have been taught by the professors of mathematics, but it is usually taught by the professors of painting, drawing and architecture. Omer Elamin Ahmed, (200) "Perspective between Theory & Practice", MA Thesis, College of Fine & Applied Art, U of Sudan,. Such a disorder of roots can be taken as a reason for the limitation of perspective within the borders of knowledge, but that is not the case, it is only the tip of the iceberg, for just

mentioning the lack of theory may point at a deeper scientific conflict more than a shortage.

All art historians recognized when dealing with the lack of naturalism in painting before the Italian Renaissance, that the simplicity of the older mind controlled the situation. It was easier for artists before the Italian Renaissance to achieve natural simulation of shapes in sculpture where sculptors could be supported by their direct sensation of touching and measuring forms, but it was too complicated to practice that in drawing or painting. The impact of visual perception such as perspective and foreshortening had not yet been absorbed. In other words, there was a lack of practicing depth and of feeling the third dimension in picture making; only flatness or a combination of easily drawn poses of some selected frontals or profiles of the human body or portraits in painting and drawing were the solutions to overcome the problem of comparing the really seen visually and the drawn shapes. The lack of perspective was controlling the situation since the Egyptian and Babylonian down to the medieval art. It was a time span of 5,400 years of experimenting with flatness and formality in painting and drawing which enabled artists to cross the borders of absorbing the ABCs of foreshortening and depth instead of flatness, and then be able to practice the linear perspective in Florence in 1425 AC with the newly born experimental mind. So it was again visual art that opened the door for the second time for the human experimental mind

Followed by the School of Alexandria in 200 BC, the Athens School put visual knowledge in the form of scientific study for the first time in human history. Two of the schools' masters, Aristotle and then Euclid, made two assumptions about the transformation of visual rays from the eye. These assumptions, as they were stated by



most art historians, initiated the knowledge which was developed in the European Renaissance by Brunelleschi, Alberti, Albert Durer and Leonardo Da Vinci, to what was known as the mathematical form of linear perspective. From that time up to the twentieth century, following historians' statements, perspective was presented as mathematical knowledge depending on Euclidean geometry.

An historical void should have to take its time to formulate and prepare the upcoming experimental mind to be ready for great changes in human history. Twentieth century historians and scientists noted these changes and considered them as a declaration of the triumph of the scientific mind in its struggle to exist. Here we can come to an agreement about the fact that linear perspective was not only a landmark on the long track of natural simulation in picture making, but aside from that it can be considered as a step of the scientific mind to maintain the experimental attitude at first, and after that the door will open wide towards understanding the logic and grammar of living phenomena such as perspective. This agreement will not lessen consideration of the geometric suggestions as a well organized, brilliant, suitable and efficient method to do the simulation process by the mentality of that time. Subsequent to that, the next five centuries of the practicing of the scientific mind may not be totally free of time voids essential for more experimenting. For the scientific mind should have to look back and retrace its footprints to see if it had or had not corrected some misleading steps which were taken during the 350 hundred centuries of practice towards its triumph. Moreover, the contemporary situation of the non rooted perspective may strengthen the debaters with the opinion of the relative mentality, because of the said scientific conflict that faces

those who want to justify these geometric suggestions in a scientific order. The seriousness of this conflict is its automatic reaction against posing theory out of the geometric roots of perspective due to the cause of an unanswered methodological question: Was perspective an invention, as Professor Martin Kamp has stated directly, or was it just a discovery leading to answer the why question of vision, as some other historians noted debating the invention opinion? Marin Kemp, (1990) "The Science of Art, Optical Themes in Western Art..." Yale University Press, , p 09. Without giving a direct answer to this question, it will be impossible to accept the logic of either side. It seems unreasonable to take one side's answer to the question and neglect the other's opinion, because when speaking about the suggested geometric roots, perspective was an invention, but when we realize that seen pictures exist as a result of visual observation, we will be asked to accept the word "invention" cautiously, for perspective should hence be treated as a discovery of living visual phenomena more than an invention.

Thereafter another question will appear automatically, emphasizing the importance of the scientific mind retracing footprints: Can we then define those Renaissance masters' efforts as research about visual phenomena? The direct answer will be no; they actually posed a geometric method to draw simulated shapes to visual illusion. This geometric method was shaped on suggested projectile orthogonal lines which represent the visual rays of vision. When drawing a picture, these orthogonal lines move from the eyes of the observer parallel to the ground level and then change their direction from the ground level upright, rising vertically towards the picture plane, passing through its horizontal lower line which is sited over the



ground level. Then using the vanishing point which is positioned in the conjunction of the central vertical line and the horizon line, and after using an elevation and a plan to maintain

the measures of e.g. a building, its landscape can be drawn, (See the 2 diagrams of the steps to draw a sectional perspective of a building below.)

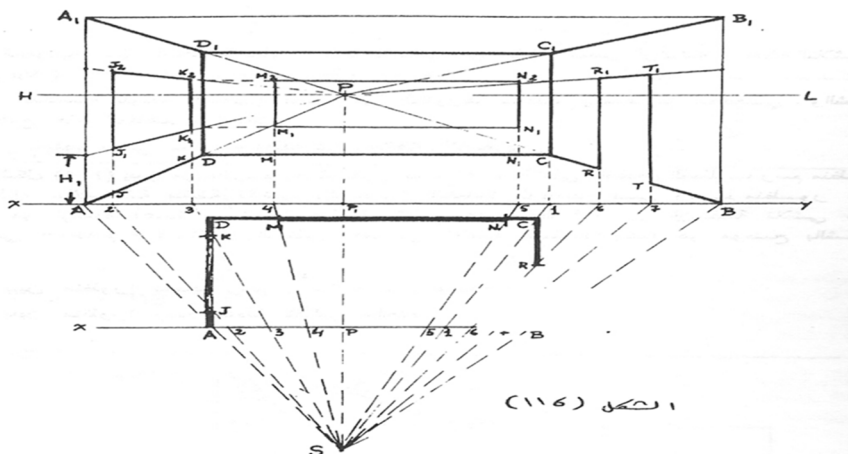
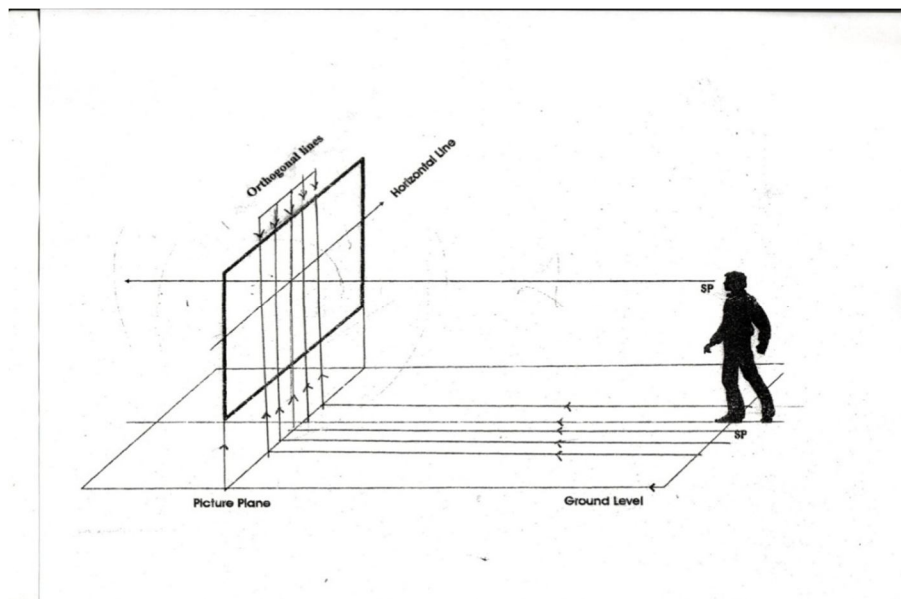



2 diagrams of the suggested visual orthogonal lines of perspective

### Results

What could be seen as results taken out from this paper is the importance of captivating the chance of administrating the research of the missed side of the geometric linear perspective and avoids missing the right time of doing that.

If it is so, we would surely miss the well equipped student who should have to provide the well equipped designer, more of that, we are going to miss the expert teachers and lecturers and research supervisors.

### conclusion

To conclude the case; two methodological tracks of research should be followed to put the geometric formula of linear perspective as an investigative case study. The two tracks are the empirical analytical methodology and the descriptive analytical historical methodology. The first one should cover the ophthalmology and optics fields of research, while the second one should cover the art and design part of the research

The aim of the research study is to find and add the missed visual side to the existing geometric experimental attitude of linear perspective. Subsequently completes its scientific situation theoretically and practically. Then maintain its teaching process.

### Recommendations

1. It is assured that the study of linear perspective is a contemporary task awaiting to

solve its persisting scientific conflict since the Italian Renaissance in the 15th century

2. It is also assured that linear perspective is an important designing tool which cannot be uninhabited out of the educational system. So, it is very important to be researched, methodologically maintained and taught.

### References

1. Martin Kemp, Prof. Science of Art, Optical Themes in Western Art from Brunelleschi to Seurat, Yale University Press. New Haven and London, 1997.
2. S. y. Edgerton Jr, Dr. The Renaissance Rediscovery of Linear Perspective, Basic Book Inc. New York.
3. Lorns Holms, Dr., Brunelleschi, Lacan, Le Corbusier, Routledge, London, 2010.
4. David Hockney, Secret Knowledge, rediscovering the Lost Techniques of the Old Masters, Thames & Hudson Ltd. London, 2001.
5. Philip Steadman, Prof. The Vermeer's Camera, Uncovering the Truth Behind the Masterpieces, Oxford University Press, New York, 2001.
- 5/6. Kiristi Andersen, Dr. Source of Mathematics and Physical Sciences, Taylor's Work on Linear Perspective, Springer – Verlag, New York, 1992
- 5/7. C. R. Wayliejr. Prof. Introduction to Projective Geometry, McGraw hill book company , New York.