



Sudan University of Science and Technology
College of Graduate Studies



Explanation of CuO Superconducting Phase Diagram by using Schrödinger Temperature Dependent Quantum Equation

تفسير منحنى الطور لأكسيد النحاس ذو التوصيل الفائق
بإستخدام معادلة شرودنجر الكمية الحرارية

*Thesis research Submitted in Partial Fulfillment of the
requirements for the degree of M.Sc. in physics*

Prepared by:

Abuobeida Abdalla Abaker Mohammed

Supervisor:

A. Dr. Mubark Dirar Abdallah

January 2017

الآية

قال تعالى:

بسم الله الرحمن الرحيم

وَقُلْ اَعْمَلُوا فَسَيَرَى اللّٰهُ عَمَلَكُمْ
وَرَسُولُهُ وَالْمُؤْمِنُونَ وَسَتُرَدُّونَ اِلٰى
عَالِيهِمْ غَيْبٍ وَ الشَّهَادَةِ فَيُنذِرُكُمْ
بِمَا كُنْتُمْ تَعْمَلُونَ { (105)

صدق الله العظيم

سورة التوبة

Just to ***Dedication***

Who have taught me a lot through the life and

Who trained me how to change to better.

Dear father.

Who taught me what is the meaning of life and

filled my heart with delight.

Dear mother.

The deepest feeling who always supported.

Dear brothers and sisters.

Who have supported me and taught me the

meaning of hope.

To my friends, colleagues and my teachers.

Acknowledgment

All thanks to Allah

*Then I would like to record my thanks to my
supervisor:*

A Dr. Moubark Dirar Abdallah

*Also my thanks to every body who helped me to
prepare this research and special thanks to my
family and teachers.*

Abstract

Quantum temperature dependence Schrodinger equation is used to describe copper oxide phase diagram for superconducting material. The equation for quantum resistance is used to find a useful equation for critical temperature which is shown to be dependent on ionic field and charges concentrations. It was shown that superconductivity is destroyed when charge carriers concentration is below or above a certain critical concentration value.

المستخلص

استخدمت معادلة شرودنجر الكمية المعتمدة على درجة الحرارة لوصف منحني الطور لأكسيد النحاس ذو التوصيل الفائق. استخدمت معادلة المقاومة الكمية للحصول على معادلة مفيدة لدرجة الحرارة الحرجة التي وجد أنها تعتمد على المجال الأيوني وتركيز الشحنات . ووجد ان التوصيل الفائق يتلاشى عندما يصبح تركيز حاملات الشحنات أقل أو أكبر من قيمة حرجة معينة .

Table of Contents

الآية	I
DEDICATIONS	II
Acknowledgment.....	III
Abstract	IV
المستخلص	<u>V</u>
Table of Contents.....	VI
Tables of Figures	VIII

CHAPTER ONE

Introduction

1.1 Superconductivity	1
1.2 Research Problem	2
1.3 Literature Review	3
1.4 Thesis Layout	3

CHAPTER TWO

Superconductivity

2.1 Introduction	4
2.2 properties of superconductor	4
2.2.1 Zero resistance	4
2.2.2 Persistent Current	5
2.2.3 Perfect diamagnetism	5
2.2.4 Energy Gap	5
2.3 London Equation.....	6

2.3.1 Derivation of first London equation:.....	6
2.3.2 Second London Equation	7
2.4 Flux quantization in superconductor	9
2.5 Bardeen – Cooper – Sheiver (BCS) Theory suffers from some noticeable setbacks. This defects include.....	12
2.5.1 Zero resistance a problem	12
2.5.2 Isotope effect	13
2.5.3 High pressure effect	14
2.5.4 Pseudo gap.....	14
2.5.5 Phase diagram.....	15

CHAPTER THREE

Explanation of Cu Phase

3.1 Introduction	17
3.2 Plasma equation	17
3.3 Quantum Temperature Equation	18
3.4 Quantum Resistance.....	19
3.5 Discussion	23
3.6 Conclusion	23
3.7 Recommendation	23
Reference :	24

List of Figures

Fig. (1. 1) Superconductivity	2
Fig. (2. 2) Resistance in normal metals and in superconductors	4
Fig. (2. 3) (a) condition gap in the normal state (b) energy gap at Fermi level in superconducting state	5
Fig. (2. 4) Zero resistance	12
Fig. (2. 5) The material is ant- ferro magnet	16
Fig. (2. 6) Phase Diagram	16

Chapter One

Introduction

1.1 Superconductivity:

Superconductivity (Sc) was discovered in 1911 in the Liden laboratory of Kamerlingh Onnes when a so called “blue boy” (local High School Student recruited for the tedious Job of monitoring experiments) noticed that the resistivity of Hg metal vanished abruptly at about 4 K [1].

Although phenomenological models with predictive power were developed in the 30.5 watt and 40.5 watt of the last [1].

F and H London developed the successful phenomenological approach in 1935 describing the behavior of superconductors in the external magnetic field [2, 3].

Ogg Jr proposed a root to high-temperature superconductivity (HTSC) introducing electron pairs in 1946 and Ginzburg and Landau proposed the phenomenological theory of the superconducting phase transition in 1950 providing a comprehensive understanding of the electromagnetic properties below T_c [4].

The microscopic mechanism underlying superconductivity was not discovered until 1957 by Bardeen Cooper and Schrieffer (BCS) [1]. Superconductors have been studied intensively for their fundamental interest for the promise of technological applications which would be possible if a material which superconducts at room temperature were discovered.

Until 1986, critical temperatures (T_c 's) at which resistance disappears were always less than about 23 K [5].

In 1986, Bednorz and Müller published a paper, subsequently recognized with the 1987 Nobel Prize, for the discovery of a new class of materials called (HTSC) which currently include members with T_c 's of about 135 K or more.

Enormous numbers of studies have been carried out to clarify the mechanism of the high temperature superconductivity (HTSC) beyond the conventional BCS theory Fig (1.1) [6].

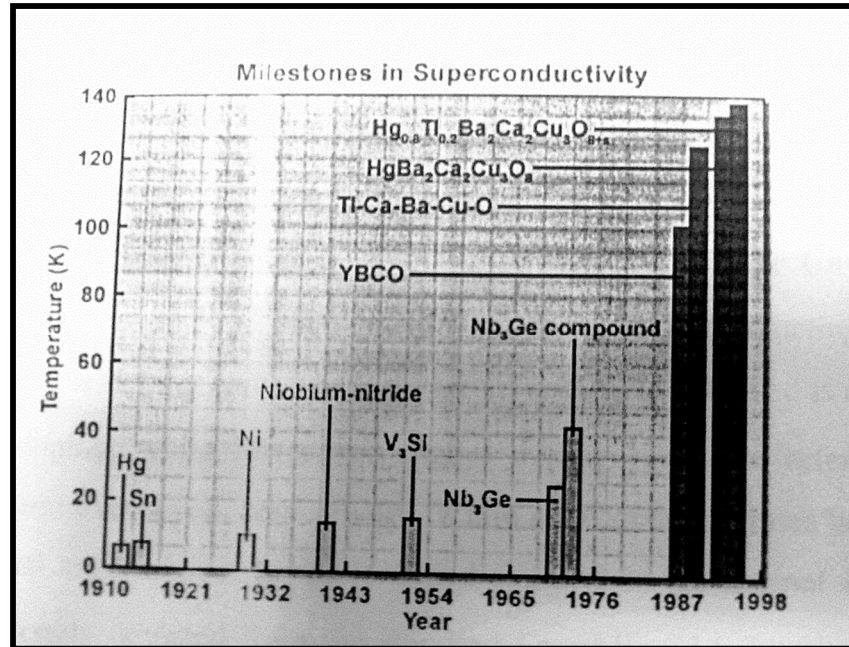

Fig 1.1: Superconductivity

One of the important HTSC is the cuprate compounds.

The cuprate systems show not only high temperature superconductivity but also show various unusual behaviors when developed with holes where it is converted from an insulator to a superconductor [7].

1.2 Research Problem:

Recently scientists discovered that some materials, like CuO, have high critical temperature above 130 K. These are called high temperature superconductors (HTSC). The behavior of these HTSC materials cannot be explained on the basis of ordinary physical theory.

1.3 Literature Review:

Different attempts were made to construct theoretical model to explain HTSC in the work done by Rashid a she utilize quantum Schrödinger equation in finding Joseph on effect equation [8].

The paper of Mubarak Dirar concerned with the effect of magnetic field and its role in destroying T_c [9].

While the theoretical model constructed by Asim Fadol shows the conditions which cause the material to act as a diode critical temperature [10].

1.4 Thesis Layout:

The thesis of consists three chapters. Chapter one and two are devoted for Introduction and superconductivity. The contribution Explanation of Cu phase Diagram is in chapter three.

Chapter Two

Superconductivity

2.1 Introduction:

In this chapter, London equations are derived, where the ordinary expression for the electron equation of motion and for the current density are utilized to find the magnetic flux density inside a superconductor. The production and destruction for conventional Sc is also present here.

2.2 Properties of superconductor:

Superconducting materials exhibit the following unusual behaviors.

2.2.1 Zero resistance:

All superconductor materials are characterized by zero resistance at below a certain critical temperature T_c .

This change in resistance and resistance drop happens abruptly or gradually as shown in Fig 2.2.

Till now there is no satisfactory expression that gives a full mathematical relation to explain these phenomena.

Below a material's T_c , the DC electrical resistivity is really zero. This leads to the possibility of related effects.

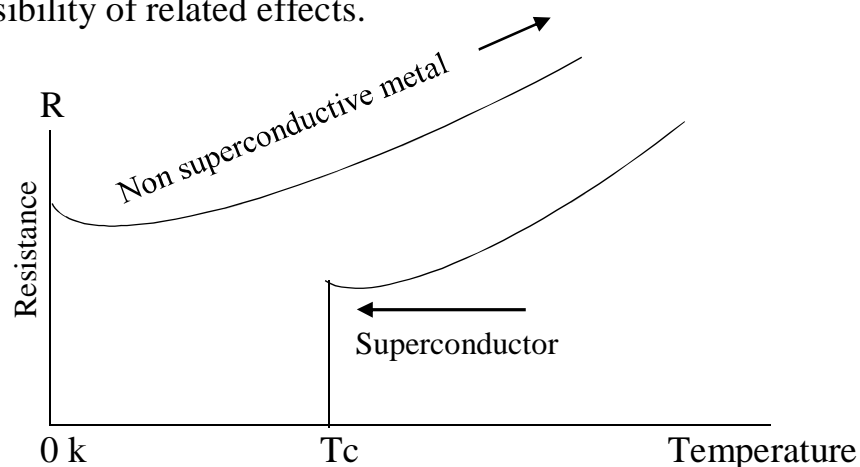

Fig 2.2: Resistance in normal metals and in superconductors

2.2.2 Persistent Current:

If a current is set up in superconductor with multiply connected topology a torus it will now forever without any driving voltage practice, experiments have been performed in which persistent currents flow for several years without signs of degrading.

2.2.3 Perfect diamagnetism:

A superconductor expels a weak magnetic field nearly completely from its interior screening current flow to compensate the field within a surface layer of few 100 or 1000 A, and the field at the sample surface drops to zero over this layer.

2.2.4 Energy Gap:

An energy gap is observed in electromagnetism spectrum. It is visible in the absorption spectrum. For if one send in a photon at low temperature (strictly speaking $T = 0$), no absorption is possible until the photon energy reaches 2Δ .

The value of the energy gap at $T = 0$, denoted by Δ_0 , is found to be proportional to T_c , when $2\Delta = 3.53 K_B T_c$, $4.51 K_B$ is Boltzman constant.

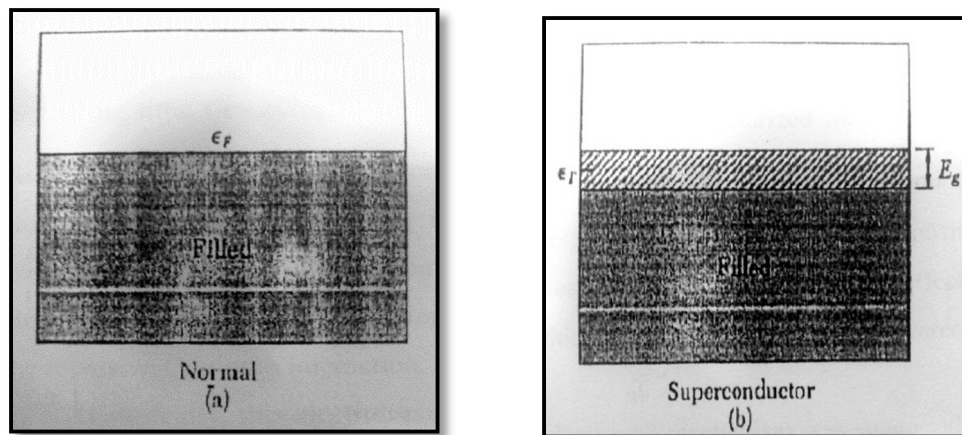

Fig 2.3: (a) condition gap in the normal state (b) energy gap at Fermi level in superconducting state

2.3 London Equation:

The London brother proposed a simple theory to explain the Meissner effect.

The London equation provided a very simple model for describing experimental results.

The 1935 theory of London brother provide the first and second London equations, which relate the electric and magnetic field E and B, respectively, inside a superconductor to the current density J

$$E = \mu_0 \lambda_1^2 \frac{dJ}{dt} \quad (2.1)$$

$$B = -\mu_0 \lambda_1^2 \nabla \times J \quad (2.2)$$

Where μ_0 the permeability of vacuum the constant of proportionality in these expressions is the London penetration depth λ_1 ,

$$\lambda_1 = \left(\frac{m}{\mu_0 n_s} C^2 \right)^{\frac{1}{2}} \quad (2.3)$$

Where n_s is density superconducting electrons, m is electron mass.

2.3.1 Derivation of first London equation:

London equation for one electrons moves in a non-resistive Medium its equation of motion is given.

$$m \frac{dv}{dt} = eE \quad (2.4)$$

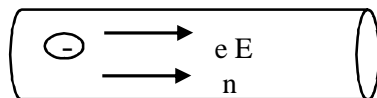

$$\frac{dv}{dt} = \frac{eE}{m}$$

But from the definition of current density “J”

$$J = n e v \quad (2.5)$$

Where n is the density of electrons

$$\frac{dJ}{dt} = ne \frac{dv}{dt} \quad (2.6)$$

From (2.6) and (2.4)

$$\frac{dJ}{dt} = ne \left(\frac{eE}{m} \right) = \frac{n e^2}{m} E \quad (2.7)$$

The term $\Lambda = \frac{m}{ne^2}$ (2.8)

Where, Λ is a phenomenological parameter equation (2.7) can this be rewritten as:

$$E = \Lambda \frac{dJ}{dt} \quad (2.9)$$

$$\text{or} \quad E = \frac{d}{dt} (\Lambda J) = \Lambda \frac{dJ}{dt}$$

This equation is known as the first London equation.

2.3.2 Second London equation:

For particle in electromagnetic field the momentum p is given by:

$$p = mv - \frac{e A}{C} \quad (2.10)$$

Where:

$A \equiv$ Magnetic potential

$C \equiv$ speed of light

For second London equation the momentum p vanishes thus:

$$0 = mv - \frac{e A}{C} \quad (2.11)$$

$$mv = \frac{e A}{C}$$

$$v = \frac{e A}{m C} \quad (2.12)$$

$$J = n e v = \frac{n e^2 A}{m C} \quad (2.13)$$

Thus:

$$\nabla \times J = \frac{n e^2}{m C} \nabla \times A \quad (2.14)$$

But from Maxwell's equation:

$$\nabla \times B = \mu J \quad (2.15)$$

$$B = \nabla \times A \quad (2.16)$$

Sub (2.16) in (2.14) to get:

$$\nabla \times J = \frac{n e^2}{\mu C} B \quad (2.17)$$

From (2.15):

$$\nabla \times \nabla \times B = \mu \nabla \times J \quad (2.18)$$

Sub (2.18) in (2.17)

$$\frac{1}{\mu} \nabla \times \nabla \times B = \nabla \times J$$

$$\frac{1}{\mu} \nabla \times \nabla \times B = \frac{n e^2}{C} B \quad (2.19)$$

Form mathematics:

$$\nabla \times \nabla \times B = \nabla(\nabla \cdot B) - \nabla^2 B \quad (2.20)$$

From Maxwell's equation:

$$\nabla \cdot B = 0 \quad (2.21)$$

From (2.21) and (2.20) and (2.19)

$$-\nabla^2 B = -\frac{\mu n e^2}{C} B = C_0 B \quad (2.22)$$

$$\frac{\partial^2 B}{\partial x^2} = C_0 B$$

This solution is:

$$B = -B_0 e^{-C_0 x}$$

$$\frac{\partial B}{\partial x} = -C_0 B_0 e^{-C_0 x} = C_0 B \quad (2.24)$$

$$\frac{\partial^2 B}{\partial x^2} = \frac{\partial}{\partial x} \left(\frac{\partial B}{\partial x} \right) = C_0 \left(\frac{\partial B}{\partial x} \right) \quad (2.25)$$

$$\therefore C_0 (-C_0) B = -C_0^2 B \quad (2.26)$$

2.4 Flux quantization in superconductor:

The total momentum of electromagnetic field is d find by:

$$P = [mv + \frac{e}{c} A]$$

$$mv = [p - \frac{e}{c} A]$$

$$v = \frac{1}{m} [p - \frac{e}{c} A] \quad (2.27)$$

The current density is thus given by:

$$J = n e v \quad (2.28)$$

From (2.27):

$$J = \frac{n e}{m} [p - \frac{e}{c} A] \quad (2.29)$$

$$n = \psi^* \psi \quad (2.30)$$

Equation (2.30) can be satisfied when:

$$\psi = n^{\frac{1}{2}} e^{i\theta} \quad (2.31)$$

$$\psi^* = n^{\frac{1}{2}} e^{-i\theta}$$

Where:

$$\theta(r) = \theta(x, y, z)$$

From (2.29)

$$J = \frac{e}{m} \psi^* \psi \left[p - \frac{e}{c} A \right]$$

$$J = \frac{e}{m} \psi^* \left[p - \frac{e}{c} A \right] \psi \quad (2.32)$$

Sub (2.31) in (2.32)

$$J = \frac{e}{m} \psi^* \left[p - \frac{e}{c} A \right] n^{\frac{1}{2}} e^{i\theta} \quad (2.33)$$

In quantum mech

$$P = \frac{\hbar}{i} \vec{\nabla} \quad (2.34)$$

Thus equation (2.33) becomes J

$$J = \frac{e}{m} \psi^* \left[\frac{\hbar}{i} \vec{\nabla} - \frac{e}{c} A \right] n^{\frac{1}{2}} e^{i\theta} \quad (2.35)$$

But

$$\begin{aligned} \nabla \left(n^{\frac{1}{2}} e^{i\theta} \right) &= n^{\frac{1}{2}} \nabla e^{i\theta} = n^{\frac{1}{2}} \frac{d}{dr} e^{i\theta} \\ &= n^{\frac{1}{2}} \frac{de^{i\theta}}{d\theta} \frac{d\theta}{dr} = n^{\frac{1}{2}} [i e^{i\theta}] \nabla \theta \\ &= i n^{\frac{1}{2}} e^{i\theta} \nabla \theta \end{aligned}$$

$$\nabla \psi = i \psi \nabla \theta \quad (2.36)$$

Sub (2.36) in (2.35)

$$J = \frac{e}{\mu} \psi^* \left[\frac{\hbar}{i} i \nabla \theta - \frac{e}{c} A \right] \psi$$

$$J = \frac{e}{\mu} \psi^* \psi \left[\hbar \nabla \theta - \frac{e}{c} A \right]$$

$$J = \frac{e n}{\mu} \left[\hbar \nabla \theta - \frac{e}{c} A \right] \quad (2.37)$$

But in side Sc:

$$J = 0$$

From (2.37)

$$\hbar \nabla \theta - \frac{e}{c} A = 0$$

$$\hbar \nabla \theta = \frac{e}{c} A \quad (2.38)$$

$$\hbar \int \nabla \theta \cdot dL - \frac{e}{c} \int A \cdot dL = 0 \quad (2.39)$$

$$dL = dr, \nabla \theta \cdot dL = \frac{d\theta}{dr} dr = d\theta \quad (2.40)$$

From vector algebra

$$\int A \cdot dL = \int \vec{\nabla} \times A \cdot d\sigma$$

$$\int B \cdot d\sigma = \int d\phi = \phi \quad (2.41)$$

Where

$$B = \vec{\nabla} \times A$$

$B \equiv$ magnetic flux density

$d\sigma \equiv$ Area (small)

$\vec{\nabla} \times A \equiv$ Magnetic potential

$\phi \equiv$ Magnetic flux

Sub (2.40) and (2.41) in (2.39) field

$$\hbar \oint d\theta = \frac{e}{c} \int d\phi$$

$$\hbar(\theta_2 - \theta_1) = \frac{e}{c} \phi \quad (2.42)$$

But θ is single raved

$$\theta_2 - \theta_1 = 2\pi$$

$$\theta_2 - \theta_1 = 4\pi$$

$$\theta_2 - \theta_1 = 6\pi$$

$$\theta_2 - \theta_1 = 2\pi s$$

$$S = 1, 2, 3, \dots$$

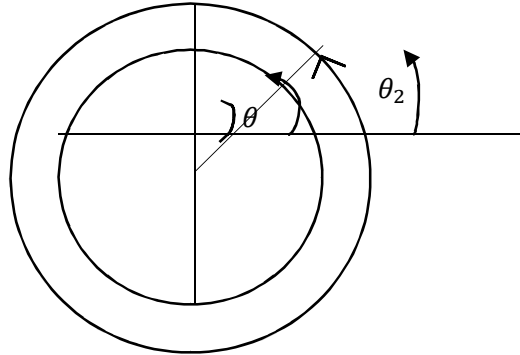

Sub (2.40) in (2.42) to get:

$$\frac{e}{C} \phi = 2\pi \hbar s = \frac{2\pi}{2\pi} h s$$

$$\phi = \frac{c}{e} h s \quad (2.43)$$

$S = 1, 2, 3$ For electrons thus the flux is quantized.

2.5 Bardeen – Cooper – Sheiver (BCS) Theory suffers from some noticeable setbacks. These defects include:

2.5.1 Zero resistance a problem:

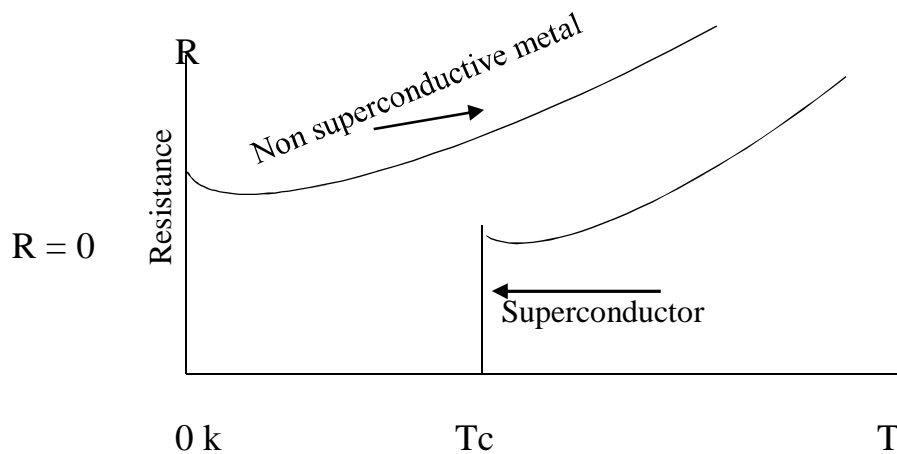

Fig 2.4: Zero resistance

In most popular “Sc” models there is a lack of a full theoretical expression which explain why the resistance drops abruptly to zero at T_c and remain zero for all values of T below the critical temperature this is very.

Important and essential since it is the most important feature that differentiate between superconducting and non-superconducting material some recent model proposed by Mubarak Dirar and other shows how R drops to zero for all $T < T_c$. Thus cannot be explained using Bardeen – cooper Sheiver theory B.c.s

2.5.2 Isotope effect:

The oxygen isotope substitutions play an important role in Sc. The replacement of one isotope by other effect the critical Temperature T_c .

The pseudo gap Temperature T^* beside the London penetration depth λ_l , all begin of function of hole doping.

The pseudo gap Temperature T^* for $\text{La}_{1.94}\text{Sr}_{0.06}\text{CuO}_4$ increases from $T^* \approx 100 \text{ k}$ to $\sim 180 \text{ k}$ when replacing 0.16 by 180. The isotope effecting $\text{La}_{2-x}\text{Sr}_x\text{CuO}_4$ and $\text{La}_{2-x}\text{Sr}_x\text{CuO}_4$ due to oxygen substitution is small at optimal doping.

But it becomes longer and becomes significant with reduced doping.

In particular near $\approx x \text{ } 0.12m \left(\frac{1}{8}\right)$ doping level, the isotope effect is anomalously strong.

Far conventional Sc the isotope effect assumes inverse relation between T_c and isotope mass, i.e

$$T_c \propto m^{-\frac{1}{2}}$$

For HT Sc, especially that are depended on hole doping the relation between T_c and in becomes.

$$\alpha = -S \ln T_c / \delta h n M$$

2.5.3 High pressure effect:

Superconducting property of a material is shown to be effected by the pressure for the majority of superconductors T_c decreases as pressure increases.

However, the situation is different for copper oxides (CuO), where T_c increases upon increasing pressure. Uniaxial pressure studies give evidence that this increase results mainly for in the reduction in the med A of the CuO_2 planes, i.e

$$T_c \propto A^{-2}$$

Rather than the reduction in the separation planes.

This indicates that superconductivity result for intra-planar pairing interaction for some compounds.

$$\frac{d \ln T_c}{dP} = -C_0 = -0.24, -0.13, -0.005 \text{ Gp}$$

$$\gamma_p = \frac{d \ln T_c}{dP}$$

2.5.4 Pseudo gap:

In high Temperature (T_c) an energy gap appear well above T_c .

This gap is called pseudo gap. This gap exists up much higher crossover

Temperature $T^* > T_c$ the pseudo gap results from the reduction $T_c < T < T^*$

This pseudo pag (E_g^*) results from reduction of density of states near Fermi energy E_f

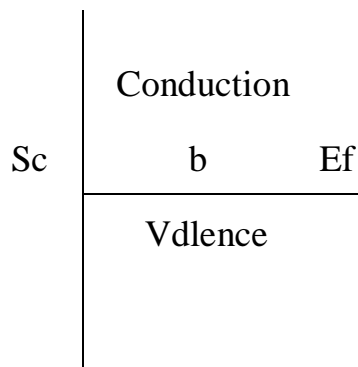

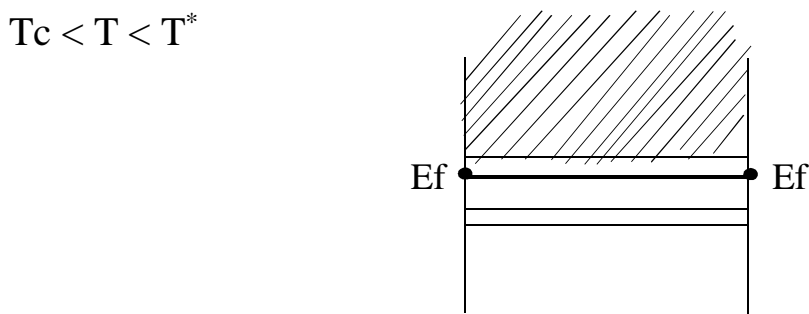
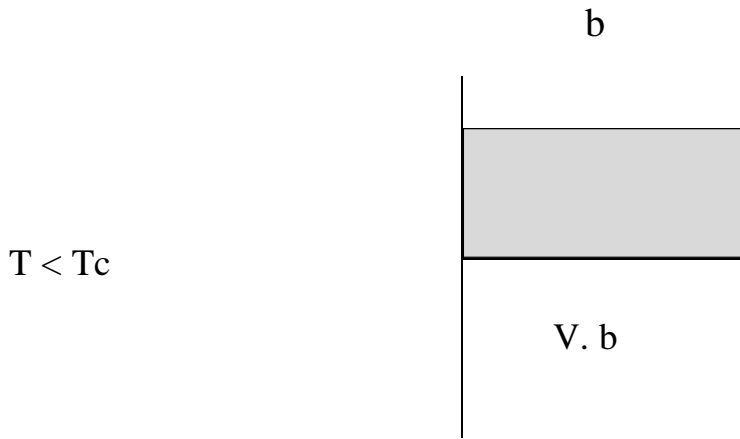

This highest T_c value exist when doping concentration.

$$X = n = 0.15$$

$(La_{2-x} , Sr_x , CuO_4)$

The $E_g^* = \Delta p \longrightarrow$ (pseudo)

Is gives by

$$E_g = \Delta p = 1.15 T^*$$

T^* = pseudo gap Temperature

This pseudo gap disappear by increasing density of states which causes gap narrowing.

2.5.5 Phase diagram:

For CuO , when we have one electron per unit cell

$$n_0 = 1$$

The material is ant-Ferro magnet (A_f) as:

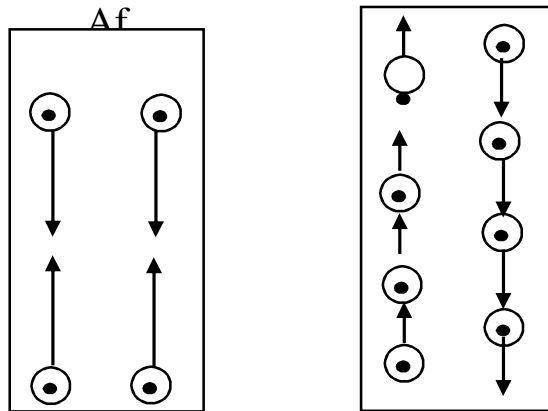
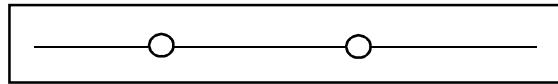

Fig 2.5: The material is ant-Ferro magnet

Well as insulator at half filling

$$n_f = 0.5 \quad , \quad n_0 = 1 \quad , \quad n_f = 0.5$$



Who n doing can centration is $n_d = 0.15$ hole per unit

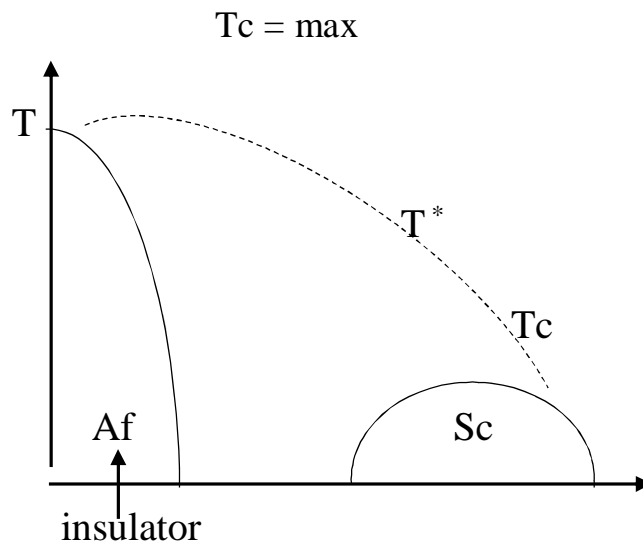

Fig 2.6: Phase diagram

(M insulator) When doping is increased the insulator is can rated to Sc.
 This cannot be explained on the basis of BCS theory.

Chapter Three

Explanation of Cu Phase Transition

3.1 Introduction:

The change of martial from insulator to super conductor when the carrier's concentration change is explained in this work.

3.2 Plasma equation:

Plasma equation describes ionized particles in a gaseous or liquid form. This equation can thus describe the electron motion easily. This is since the electrons be behaves as ionized particles inside matter.

For pressure exerted by the gas plasma equation becomes:

$$m n \frac{dv}{dt} = -\nabla P + F \tag{3.2.1}$$

Where:

m is mass of electron

n is number of particles

But for pressure exerted by medium on the gas, the equation become:

$$m n \frac{dv}{dt} = \nabla P + F = \nabla P - \nabla V \tag{3.2.2}$$

In on dimensions, the equation become:

$$m n \frac{dv}{dx} \frac{dx}{dt} = \frac{d nkT}{dx} - \frac{d n V}{dx}$$

$$m n v \frac{dv}{dx} = \frac{d}{dx} [nkT - nV] \tag{3.2.3}$$

Where v is the potential for one particles

$$m n \frac{d}{dx} \left(\frac{1}{2} v^2 \right) = \frac{d}{dx} [nkT - nV]$$

Thus in integrating both sides by assuming n to be constant or independent of k fields.

$$\frac{n}{2} m v^2 = nkT - nV + c$$

$$\frac{1}{2} m v^2 + V - kT = \frac{c}{n} = \text{constant} = E$$

This constant of motion stands for energy thus

$$E = \frac{P^2}{2m} + V - kT \quad (3.2.4)$$

3.3 Quantum Temperature Equation:

To find temperature depended quantum equation, multiply by ψ to get:

$$E\psi = \frac{P^2}{2m}\psi + V\psi - kT\psi \quad (3.3.1)$$

According to where nature of particles

$$\psi = A e^{\frac{i}{\hbar}(px - Et)} \quad (3.3.2)$$

Thus

$$\left. \begin{aligned} i\hbar \frac{\partial \psi}{\partial t} &= E\psi \\ -\hbar^2 \nabla^2 \psi &= P^2 \psi \end{aligned} \right\} \quad (3.3.3)$$

$$i\hbar \frac{\partial \psi}{\partial t} = \frac{-\hbar^2 \nabla^2}{2m} \psi + V\psi - kT\psi \quad (3.3.4)$$

The time independent equation becomes:

$$\frac{-\hbar^2 \nabla^2}{2m} \psi + V \psi - kT \psi = E \psi \quad (3.3.5)$$

Consider the case when these electrons were subjected to constant crystal field V_0 . This assumption is quite natural as far as particles are distributed homogeneously around the moving charge carrier.

Thus, equation (3.3.5) become:

$$\frac{-\hbar^2 \nabla^2}{2m} \psi + V_0 \psi - kT \psi = E \psi \quad (3.3.6)$$

One can suggest the solution to be:

$$\psi = A e^{ikx} \quad (3.3.7)$$

A direct substitution yields:

$$\left(\frac{-\hbar^2 \nabla^2}{2m} + V_0 - kT \right) \psi = E \psi$$

There for

$$K = \frac{\sqrt{2m (E + kT - V_0)}}{\hbar} \quad (3.3.8)$$

This wave number k is related to momentum according to the relation:

$$p = mv = \hbar k = \sqrt{2m (E + kT - V_0)} \quad (3.3.9)$$

3.4 Quantum Resistance:

To find the quantum resistance R of a certain low of R to

$$R = \frac{V}{I} \quad (3.4.1)$$

V = potential I = current

For electrons accelerated by the potential the work done is related to potential V and kinetic energy K

$$w = V = \frac{1}{2} m v^2 \quad (3.4.2)$$

But since the current I is given by:

$$I = n e v A \quad (3.4.3)$$

$$R = \frac{m v^2}{2 n e A v} = \frac{m v}{2 n e A} \quad (3.4.4)$$

$$R = \frac{P}{2 n e A} \quad (3.4.5)$$

$$R = \frac{\sqrt{2 m (E + k T - V_0)}}{2 n e A} \quad (3.4.6)$$

Splitting R to real part R_s and imaginary R_i , one can write:

$$R = R_s + R_i \quad (3.4.7)$$

According to equation (3.4.6) becomes pure imaginary

$$E + k T - V_0 < 0$$

$$k T < V_0 - E$$

$$T < \frac{V_0 - E}{K} \quad (3.4.8)$$

Let the potential be related to the potential per unit ionic atom, i.e

$$V_0 = n_0 V_a \quad (3.4.9)$$

V_a = potential of one ion

Where n_0 is superconducting carrier's concentration which is the equal to the crystal ions charge concentration.

$$R = \frac{\sqrt{2 m (E + k T - n_0 V_a)}}{2 n e A} \quad (3.4.10)$$

$$= R_r + i R_i = R_s + i R_i \quad (3.4.11)$$

For superconducting state

$$R_s = R_i = 0 \quad (3.4.12)$$

Thus according to equation (3.4.10) gives:

$$R = i R_i$$

This equation

$$(E + kT - n_0 V_a) < 0$$

$$kT < n_0 V_a - E$$

Hence the critical temperature is given by:

$$T_c = \frac{n_0 V_a - E}{k} \quad (3.4.13)$$

When the charge concentration $n \neq n_0$, $V_0 = n V_a$

Equation

$$R = \frac{\sqrt{2m (E + kT - n V_a)}}{2ne A} \quad (3.4.14)$$

$$R = \frac{\sqrt{2m k(T - T_c) - (n - n_0)V_a(2m)}}{2ne A} = R_r + R_i$$

Where

$$R_s = R_r \quad (3.4.15)$$

When Sc is destroyed

$$R_s = R_r \neq 0 \quad (3.4.16)$$

In this case

$$2m k(T - T_c) - (n - n_0)V_a(2m) > 0$$

$$-(n - n_0)V_a > 2mk (T_c - T)$$

$$(n - n_0)V_a < 2mk (T_c - T)$$

For $T = 0$, one gets

$$(n - n_0)V_a < 2mkT_c$$

This equation requires

$$n < n_0 + \frac{2mkT_c}{V_a} \quad (3.4.17)$$

While for $T = T_c = 0$

$$(n - n_0)V_a < 0$$

This requires

$$n < n_0 \quad (3.4.18)$$

$$n < \frac{2mkT_c}{V_a} + n_0 \quad (3.4.19)$$

This means that Sc is destroyed

Where n is less than the optimum value n_0

But when the potential is effected by attractive ion potential, beside repulsive electron cloud potential

$$V_0 = -n_0V_a + n_cV_c \quad (3.4.20)$$

V_c = electron cloud potential

n_c = electron or hole concentration

In this case

$$R = \frac{\sqrt{2m k(T - T_c) - 2(n - n_0)mV_a + 2n_cV_cm}}{2neA} \quad (3.4.21)$$

$$R_s \neq 0 \quad (3.4.22)$$

$$2m k(T - T_c) - 2mV_a(n - n_0) + 2n_cV_cm > 0 \quad (3.4.23)$$

$$n_c > \frac{2m k(T_c - T) + 2mV_a(n - n_0)}{2mV_c}$$

$$0 \leq T < T_c$$

When $T = 0$

$$n_c > \frac{kT_c}{V_c} + \frac{V_a}{V_c}(n - n_0) \quad (3.4.24)$$

But when $T = T_c = 0$

$$n_c > \frac{V_a}{V_c}(n - n_0) \quad (3.4.25)$$

Thus for all T such that $0 \leq T < T_c$

$$n_c > \frac{kTc}{V_c} + \frac{V_a}{V_c}(n - n_0) \quad (3.4.26)$$

3.5 Discussion:

The contribution was made by using Schrödinger temperature dependent quantum equation (3.3.7). Equation (3.4.1) and (3.4.6) gives quantum resistance and their temperature dependence it is clear from equations (3.4.13) that doping concentration contribute to critical temperature. Equation (3.4.17) show that when the concentration of free charge is low the T_c is destroyed. In this case extrinsic free charge are negligible. But when extrinsic free carriers become significant as equation (3.4.20), the T_c is destroyed when extrinsic free carriers exceeds certain value (see (3.4.26)).

Which conforms with the phase diagram agrees with experiments.

3.6 Conclusion:

Schrödinger temperature quantum model shows its capability in describing the Cu phase diagram. This means that model which was simple mathematics agree with experiments.

3.7 Recommendation:

The quantum Schrödinger model need to be used also to describe the hopping process and to solve all setbacks of conventional T_c theories.

Reference:

- [1] Charles Kittel, (1976), introduction to solid state physics. John Wiley and Sons, New York.
- [2] As Alexandrov, (2003), theory of superconductivity from weak to strong coupling, IOP publishing UK.
- [3] Hajime Yogi, (2005), photoemission study of the high temperature superconductor $YBa_2Cu_3O_y$ thesis, university of Tokyo.
- [4] N.B Kopnin, (2008), the theory of superconductivity, TFY-3.4801 (5 Cr) pv. 212 HUT Fall.
- [5] Sexens, A.K, (2009), High Temperature Sc, springer, New York.
- [6] A. Zakaria, et al , 6(2): April – June 2016, Quantum effect of magnetic field in destroying Sc, Int, J of Eng. Sci. and manage, Zakaria.
- [7] M. Dirar, et al, 3(4): April 2016, Int. J. of Eng. Sci and Res, Abdallah,.
- [8] Rashida. I, et al, , 8, 85 – 88 (2016), Natural Science.
- [9] A. Atambori et al, June (2016), Quantum relation between Sc resistance and energy gap, Glob J. of Eng. Sci and res, Altambori, 3(6).
- [10] Asim. A. M. Fadol, et al, 2(8): Aug (2015), current rectification of quantum nano diode in Sc atate, Glob J. of Eng. Sci and Res, Fadol.