

## Chapter 4

### The feeder automation of Abdu Gaffer substation

#### 4-1 Introduction:-

An electric power distribution system is the final stage in the delivery of electric power. It carries electricity from the transmission system to individual consumers. The transmission system carries high voltage of (220kv, 110kv) and stepped down by the transformers located in the distribution substation.

Power system has many transmission and distribution substations scattered around the country and connected together by overhead lines. These connections ensure transfer of information between the substations.

The transmission and distribution substations of Omdurman are shown in fig (4-1)

Where colors of the block are representing as shown below:-

Color	clarify
Red Blue Yellow	→ 220KV
Red Blue Gray	→ 110KV
Gray Red	→ 33 KV

The automated control center in Khartoum is responsible in all control and monitoring operations for the electric power systems.

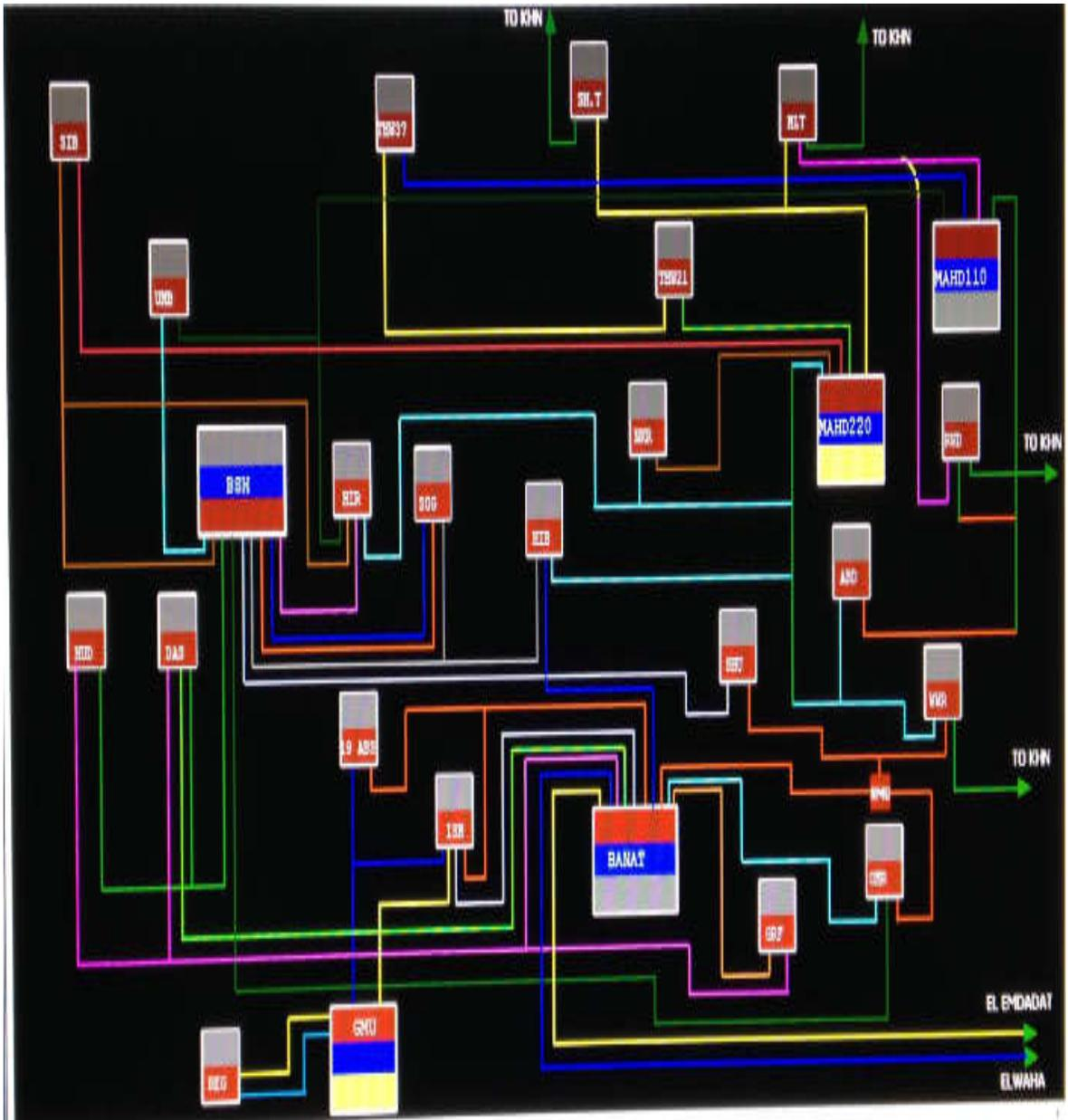

Fig(4-1)The Basic Transmission and Distribution Substation of Omdurman.

## **4-2 Operating principle of circuit breaker (C.B):-**

A circuit breaker essentially consists of fixed and moving contacts, called electrodes. Under normal operating conditions, these contacts remain closed and will not open automatically until and unless the system becomes faulty. Of course, the contacts can be opened manually or by remote control whenever desired. When a fault occurs on any part of the system, the trip coils of the circuit breaker get energized and the moving contacts are pulled apart by some mechanism, thus opening the circuit.

When the contacts of a circuit breaker are separated under fault conditions, an arc is struck between them. The current is thus able to continue until the discharge ceases. The production of arc not only delays the current interruption process but it also generates enormous heat which may cause damage to the system or to the circuit breaker itself. Therefore, the main problem in a circuit breaker is to extinguish the arc within the shortest possible time so that heat generated by it may not reach a dangerous value. The common used Sulfur hexafluoride circuit breaker (SF<sub>6</sub>) gas is an alternative to air as an interrupting medium. SF<sub>6</sub> is a colorless nontoxic gas, with good thermal conductivity and density approximately five times that of air.

## **4-3 Bus bar arrangements:-**

The most commonly bus bar arrangement used in substations are:

- Single bus bar arrangement.
- Double bus bar arrangement.
- Single bus bar arrangement with sectionalizing switch.

The single bus bar arrangement with sectionalizing switch is used in Abdu Gaffer substation in Omdurman is shown in figure (4-2) below:

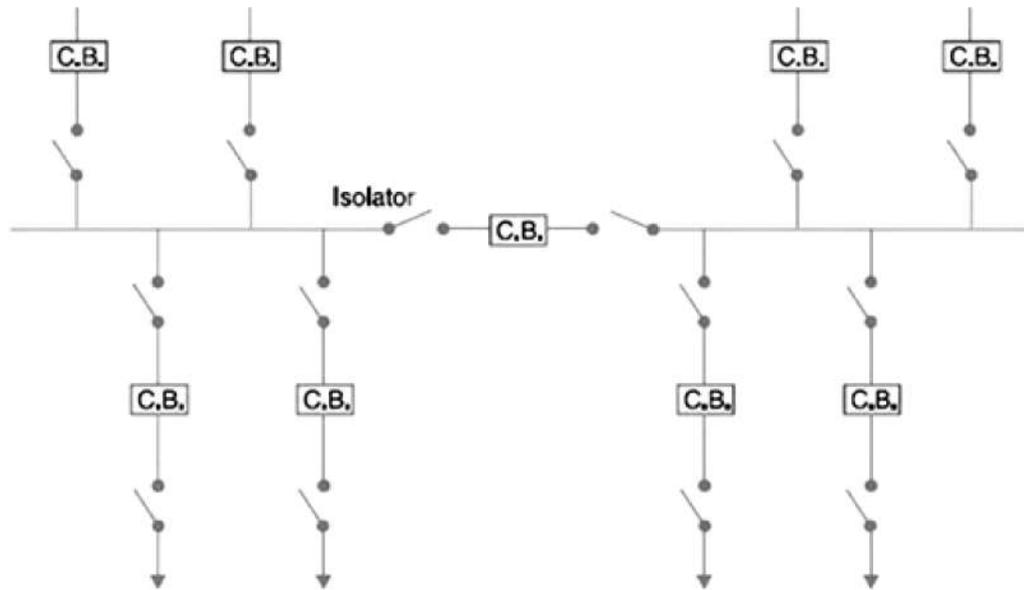

Fig (4-2) Single bus bar arrangement with sectionalizing switch

If there are more than one incoming and outgoing feeders are evenly distributed on the sections as shown in the figure above, interruption of system can be reduced to a good extent.

The Advantages of this bus bar that if any one of the sources is out of system, still all loads can be fed by switching on the sectional circuit breaker or bus coupler breaker and if one section of the bus bar system is under maintenance, part load of the substation can be fed by energizing the other section of bus bar.

Where the disadvantage is in the case of single bus system, maintenance of equipment of any part cannot be possible without interrupting the feeder or transformer connected to that part.

#### 4-4 system components:-

The actual automation substation in Abdu Gaffer is represented in fig (4-3)

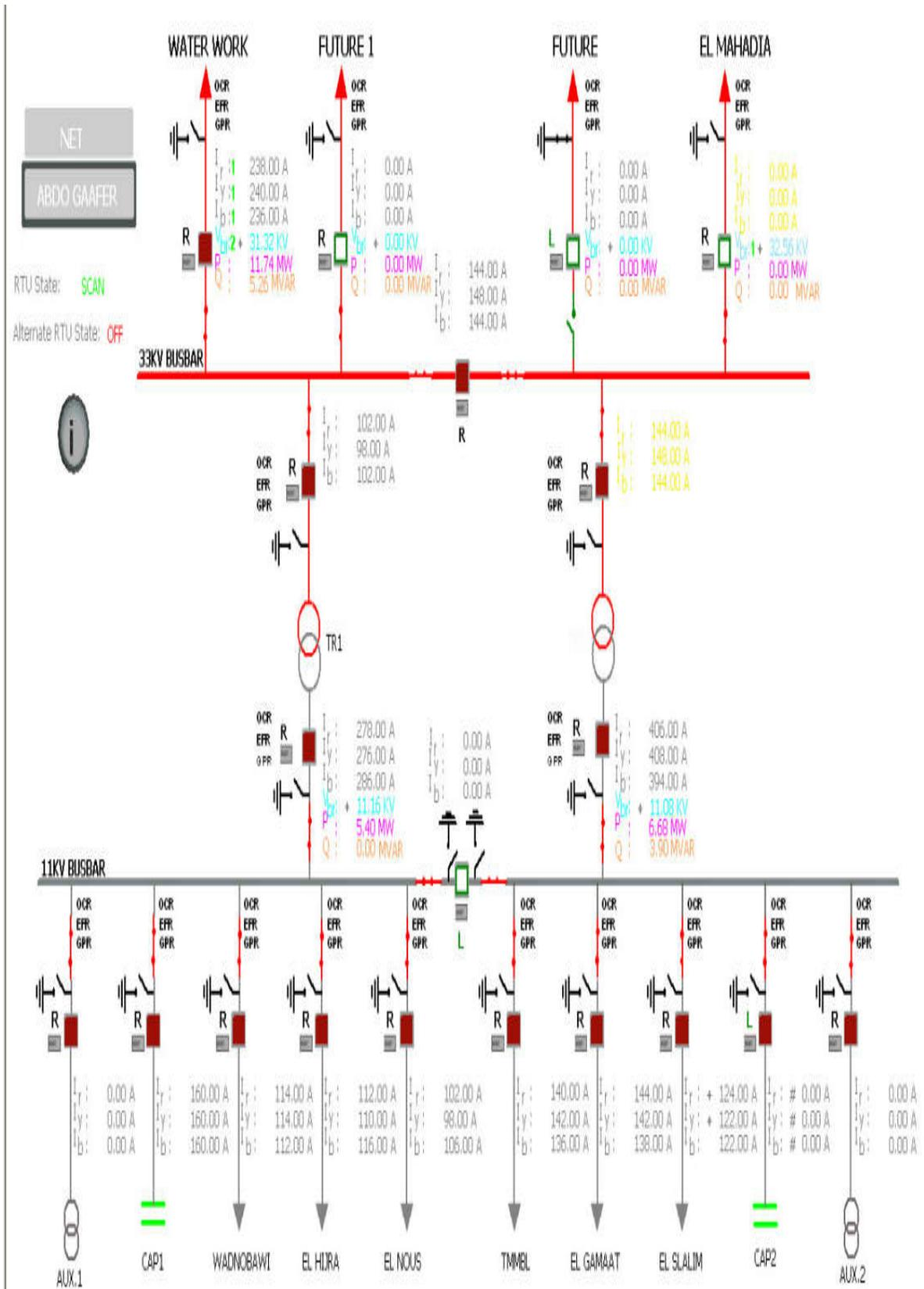

Fig (4-3)Abdu Gaffer Substation

#### **4-5 system operation:-**

The line of high voltage of 33KV transmission line is connected to bus bar through circuit breaker of 33KV. This voltage stepped down to the medium voltage of 11KV by using step down transformer at the distribution substation to be suitable for distribution line. It's necessary that any substation supposed to have two steps down transformers that independent of each other but connected at the same bus bar. The rated MVA of any transformer is more than the total MVA load connected .If any fault happens in one of these transformers there is a bus section switch which connects the bus bar together when a fault occur in any one of the transformer to ensure continuity of the supply. It's operating automatically to connect the bus bar together and isolate the faulty transformer. These 11KV lines are also connected through circuit breaker of each line and the control operation related at these circuit breakers. Primary distribution lines carry this medium voltage power to distribution transformers located near the customer's premises. Distribution transformers again lower the voltage to the utilization voltage of household appliances and typically feed several customers through secondary distribution lines at this voltage. Commercial and residential customers are connected to the secondary distribution lines through service drops. Customers demanding a much larger amount of power may be connected directly to the primary distribution level or the sub transmission level.

#### **4-6 system simulation:-**

The simulation replaced SCADA system (open 3000 & spectrum) application which used in power system control by SIMATIC WinCC flexible 2008 application it is shown in fig (4-4).

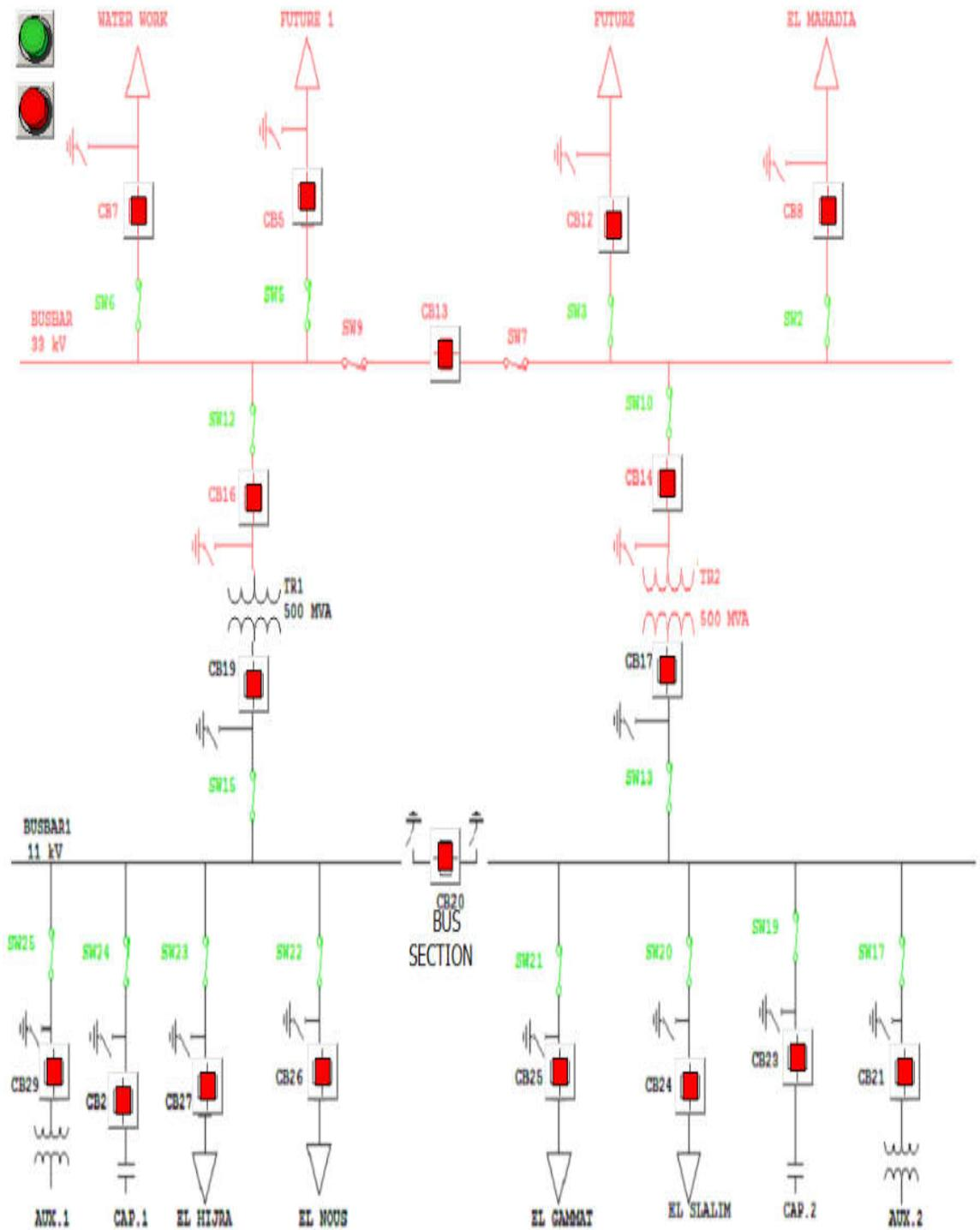
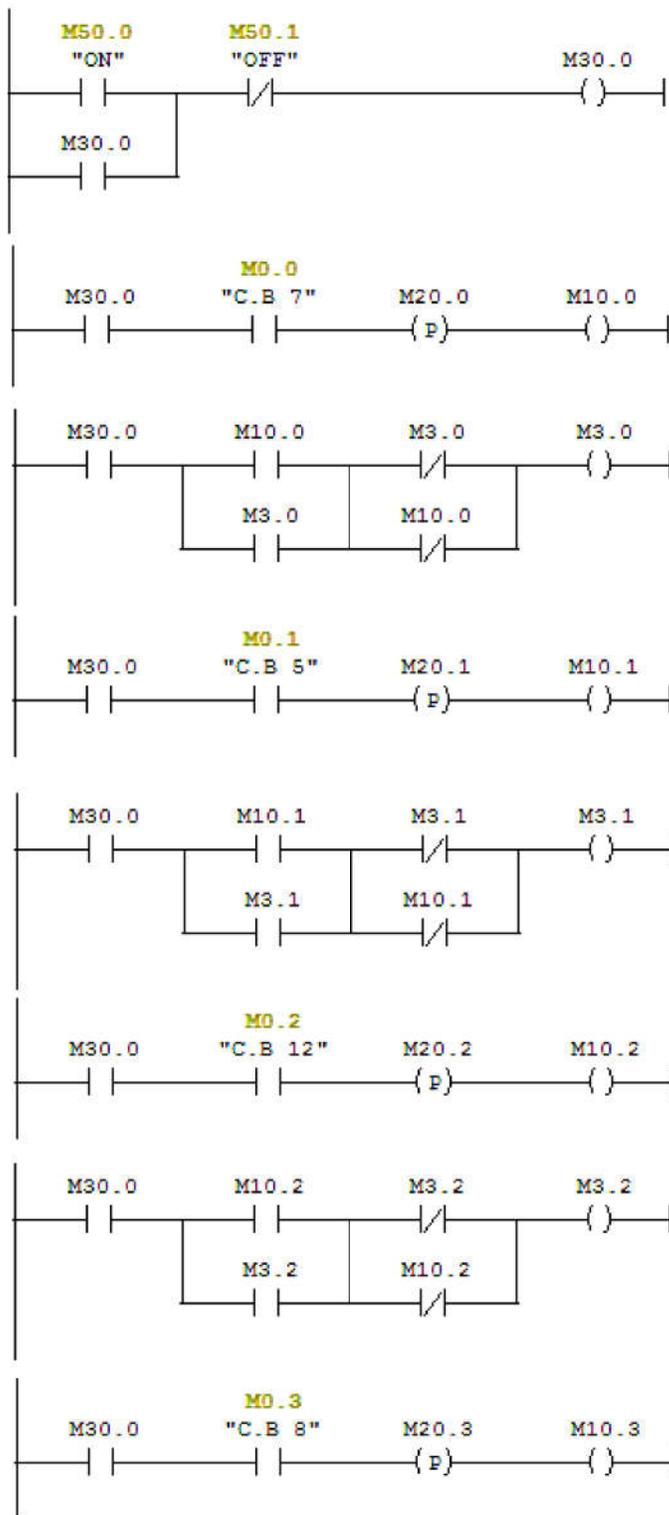
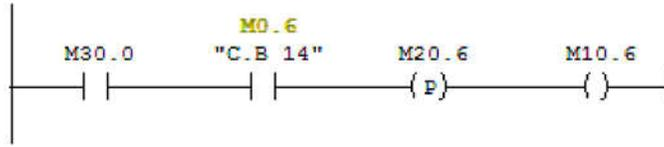
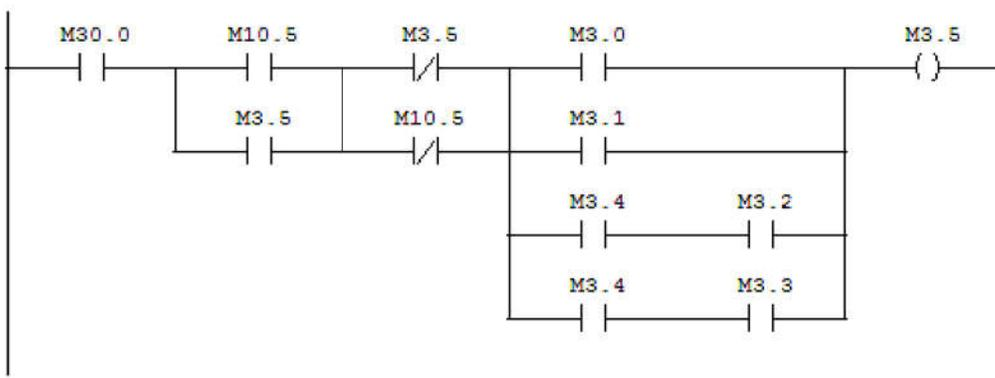
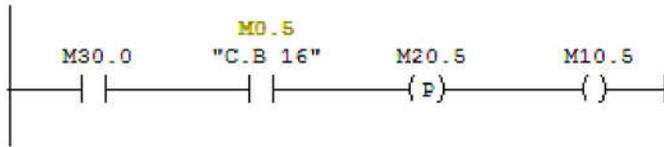
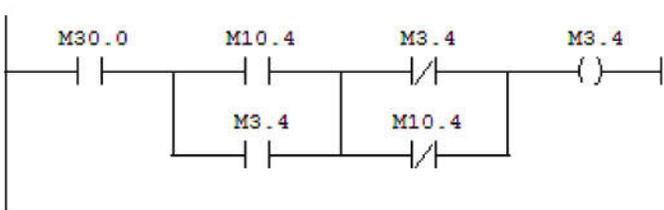
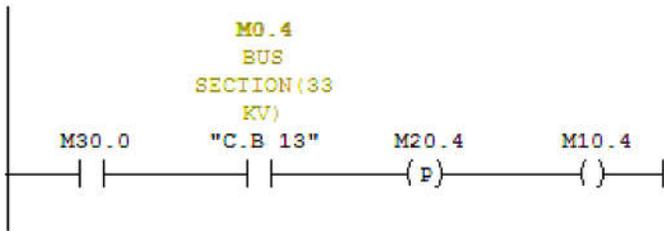
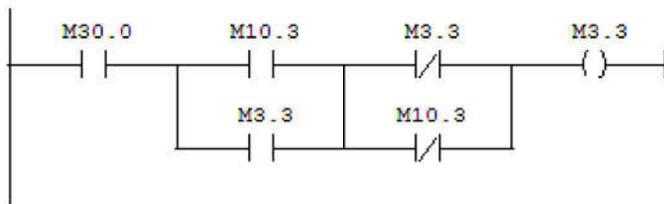
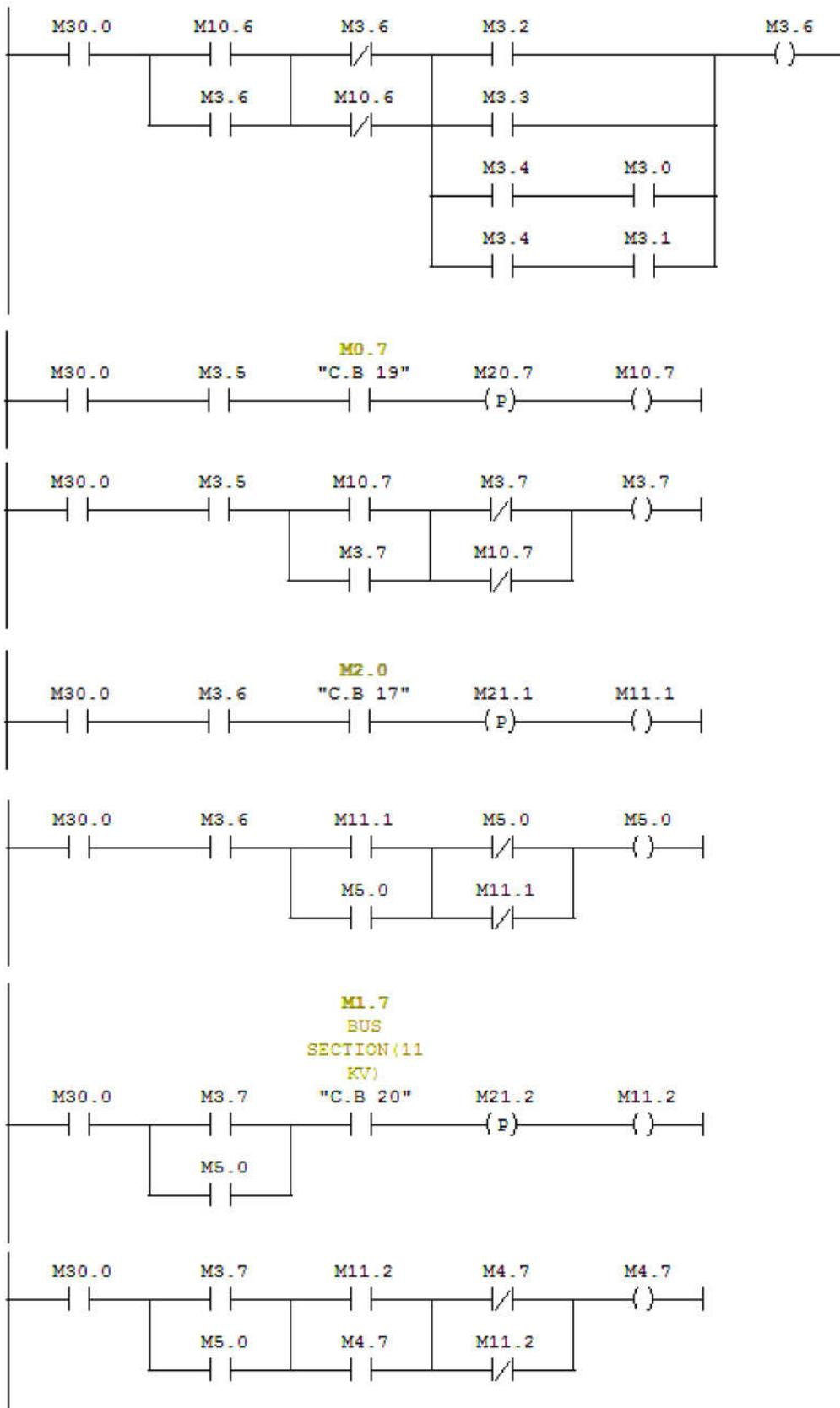

Fig (4-4) System Simulation

This application programmed by PLC which programmed with ladder diagram wrote in step7 300 v5.5 applications as shown below:







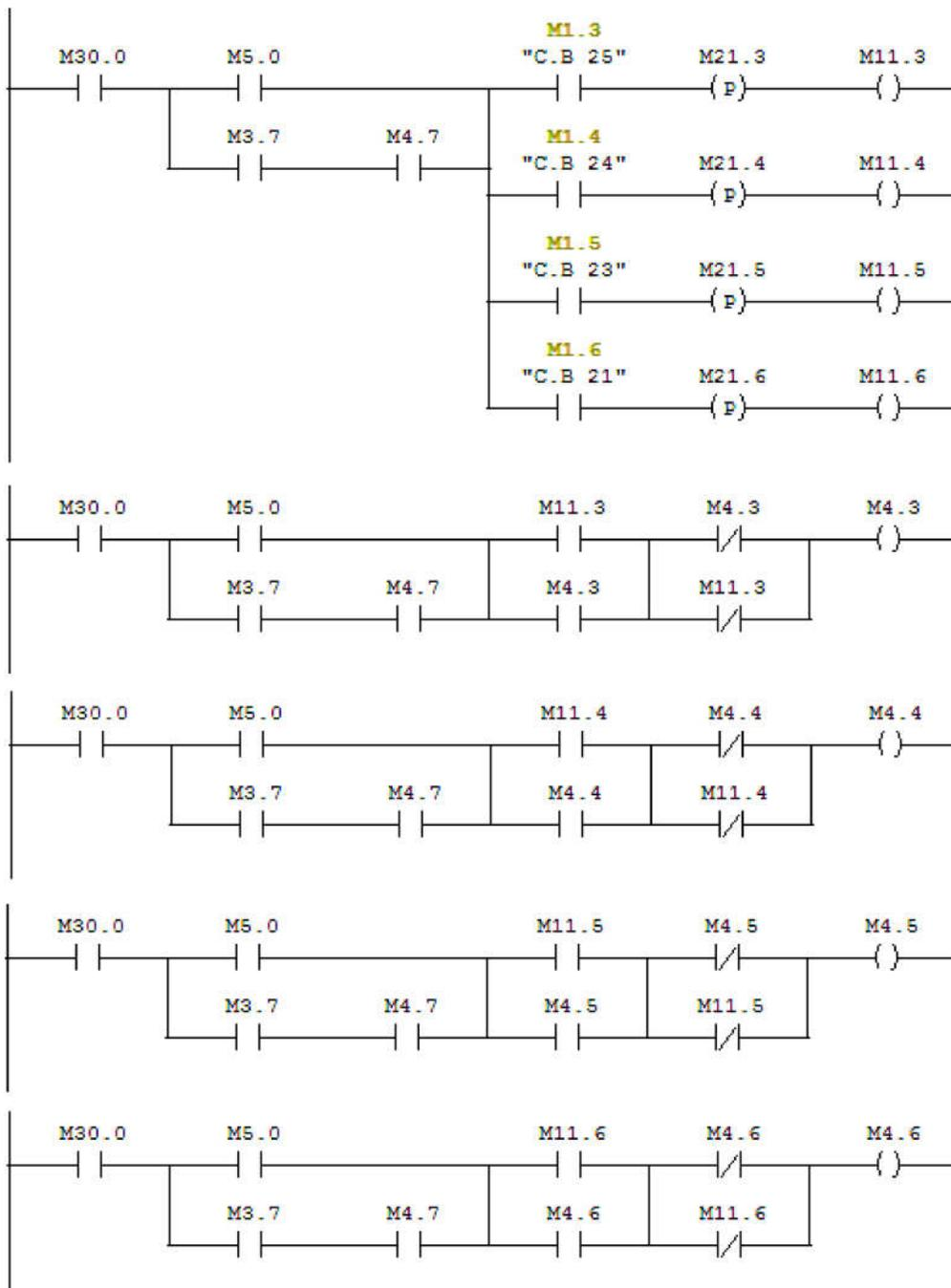

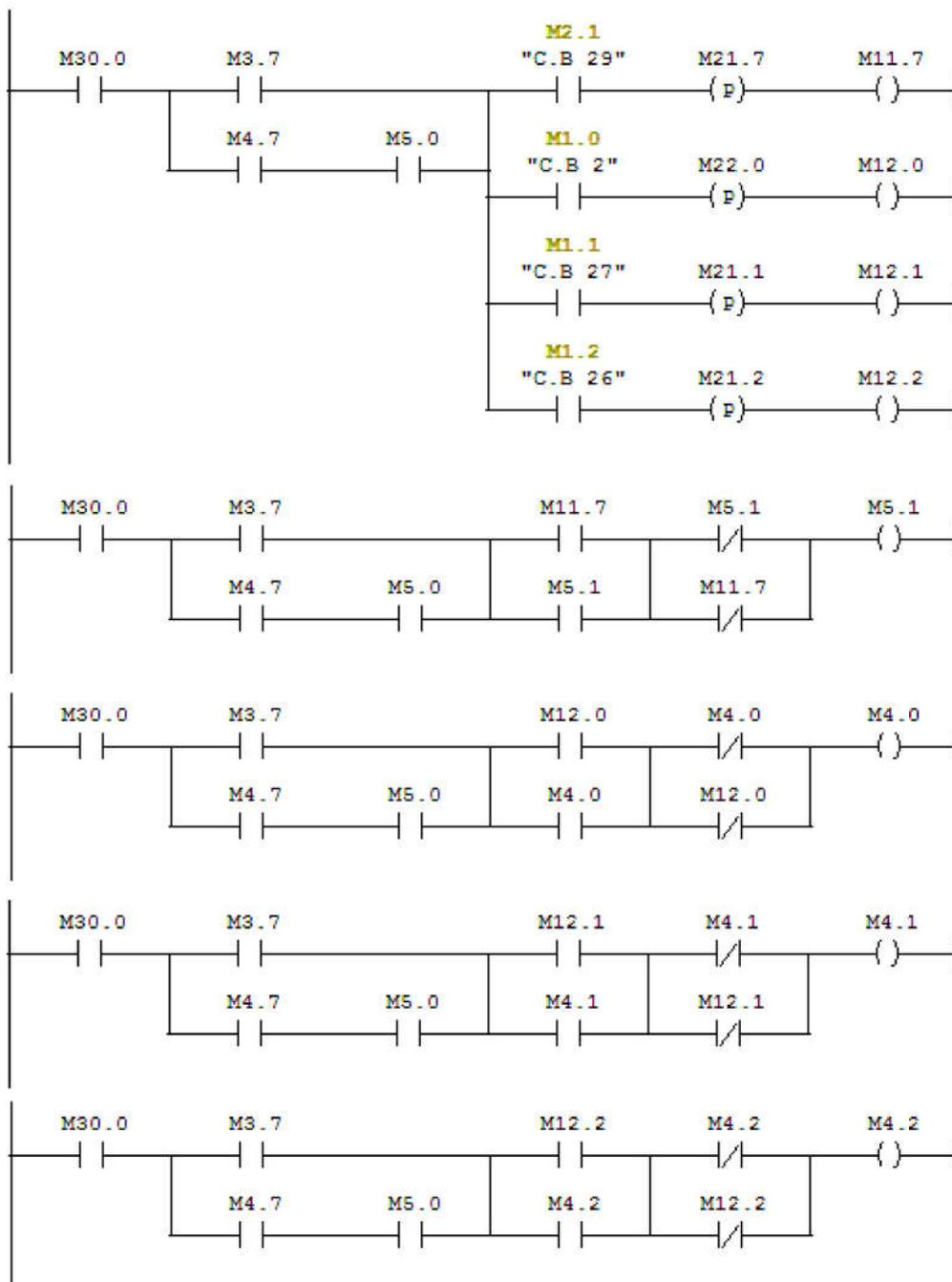

There are three situations that make operator to control the circuit breakers:

- In the case of maintenance.
- In the event of fault.
- In the case of overloading.