

قال تعالى

(هُوَ الَّذِي جَعَلَ الشَّمْسَ ضِيَاءً وَالْقَمَرَ نُورًا  
وَقَدَرَهُ مَنَازِلَ لِتَعْلَمُوا عَدَدَ السِّنِينَ وَالْحِسَابَ مَا  
خَلَقَ اللَّهُ ذَلِكَ إِلَّا بِالْحَقِّ يُفَصِّلُ الْآيَاتِ لِقَوْمٍ  
يَعْلَمُونَ)

صدق العظيم

سورة يونس اية (5)

# DEDICATION

We dedicate this project to our creator and source of strength throughout these years. We also dedicate this work to our families for providing us with unfailing support and continuous encouragement this accomplishment would not have been possible without them, and special thanks to our mothers who never stopped believing in us. We also want to dedicate this project to our friends and colleagues with whom we shared this journey.

# ACKNOWLEDGEMENT

We would like to thank our project advisor Ust. Omer Salama of the control department, School of electrical and nuclear engineering collage of engineering at Sudan University who allowed this project to be our work, but steered us in the right direction whenever we asked for help.

## **ABSTRACT**

Robotics has been acknowledged as a mainstay in the industrial domain for decades .It has gradually become essential in vehicle, military and medical domain. In this project a six axes industrial arm had been modeled and designed to show how the actual version of industrial robotic arms work and controlled. a servo motor used as a manipulator to move the mechanical parts and the end effector (the gripper), Arduino Uno as a controller and sensor, with this component a production line has implemented.

## المستخلص

صارت ا ذرع الصناعية جزء أساسي في أشكال الصناعة المختلفة, في هذا المشروع صممت ذراع آلية ذات خمس درجات حرية ومثلت أجزاء الذراع الصناعية التي تستخدم التيار المتردد غالباً بنماذج مصغرة تحاكي عملها وتعمل بالتيار المستمر؛ استخدمت محركات سيرفو تعمل بالتيار المستمر لتمثل المحركات التي تستخدم عادة في الصناعة كالمحركات الكهربائية او الهيدروليكية او التتعمل بضغط الهواء (pneumatic). استخدمت متحكمة أردوينو لتمثل المتحكمات التي تستخدم في الصناعة PLC, DCS, PCS مع محساس ضوئي, ومن خ ل هذه المكونات با ضافة الى خط إنتاج مثل نموذج مصغر لذراع آلية صناعية.

# TABLE OF CONTENTS

	Page
أ ية	i
DEDICATION	ii
ACKNOWLEDGEMENT	iii
ABSTRACT	iv
مستخلص	v
TABLE OF CONTENTS	vi
LIST OF FIGURES	vii
LIST OF TABLES	vii
<b>CHAPTER ONE</b> <b>INTRODUCTION</b>	
1.1 General Concepts	1
1.2 Problem Statement	1
1.3 Objectives	2

1.4 Methodology	2
1.5 Project Layout	2
<b>CHAPTER TWO</b>	
<b>BACK GROUND AND EVOLUTION</b>	
2.1 Introduction	3
2.2 Classification of Robots	4
2.3 Robots Development	10
2.4 Industrial Robot Component	13
2.5 Industrial Robot Applications	14
2.6 Benefits of Industrial robots	15
2.7 Conclusion	16
<b>CHAPTER THREE</b>	
<b>ROBOT MAIN COMPONENTS</b>	
3.1 Introduction	17
3.2 Servo Motors	17
3.3 Arduino	21
3.4 Sensor	25
3.5 Belt Conveyer	29
<b>CHAPTER FOUR</b>	

<b>DESIGN AND IMPLEMENTATION</b>	
4.1 Introduction	35
4.2 Block Diagram	37
4.3 Mechanical Calculations	38
4.4 Design	40
4.5 Procedure	43
<b>CHAPTER FIVE</b>	
<b>CONCLUSION AND RECOMMENDATIONS</b>	
5.1 Conclusion	44
5.2 recommendations	44
REFERENCE	45

## Chapter One

### Introduction

#### 1.1.General Concept

A robotic arm is a robotic manipulator, usually programmable, with similar functions to a human arm. Humans pick things up without thinking about the steps involved. In order for a robot or a robotic arm to pick up or move something, someone has to tell it to perform



several actions in a particular order, from moving the arm, to rotating the “wrist” to opening and closing the “hand” or “fingers”. So, we can control each joint. . This paper presents a robotic arm which can be used in industries to do repetitive task such as moving the things from conveyor to another place, a sensor will be used to detect the obstacles if present while carrying out the task.

The first programmable robot is designed by George Devol ,he coins the term universal automation in 1956.And it kept evolving through the years and in 1974 a robotic arm (the silver arm) ,that performed small part assembly using feedback from touch and pressure sensor was designed .1978:The Puma (Programmable Universal Machine for Assembly) robot is developed by Unimation with a General Motors design support.1980s: The robot industry enters a phase of rapid growth.Many institutions introduce programs and courses in robotics.Robotics courses are spread across mechanical engineering, electrical engineering, and computer science departments.1995-present: Emerging applications in small robotics and mobile robots drive a second growth of start-up companies and research.

## **1.2 Problem Statement**

Industrial operations need high accuracy and efficiency and consistent speed and precision, and these jobs might be too dangerous,dirty, boring or just impossible for a human to perform.

## **1.3 Objective**

To achieve industrial tasks and perform operations more cheaply and with greater accuracy and reliability than humans, and do the jobs that are not suitable for humans, whether they are too dangerous, too exposed to toxins or just plain too dirty for humans to conveniently do them, these are ideal robotics tasks.

## **1.4 Methodology**

We designed a simple model for an industrial robotic arm using the same construction of the actual industrial robotic arms ; using a servo motor as an actuator , Arduino Uno as a controller and IR sensor ,powered by a DC power source (5-12) volts, along with a small model of a conveyer as a production line.

## **1.5 Project Layout:**

Chapter one presents introduction of project.

Chapter two presents industrial robot background and evolution.

Chapter three presents main components.

Chapter four presents design and implementation.

Chapter Five presents conclusion and recommendations.

## **Chapter Two**

### **Industrial Robotic Back Ground And Evolution**

#### **2.1. Introduction**

An Industrial robot is an automatically controlled, reprogrammable, multipurpose, manipulator programmable in three or more axes, which may be either fixed in place or mobile for use in industrial automation applications. Industrial robots are used as transporting devices (material handling of work pieces between machines) or in some kind of additive- (e.g. assembly, welding, gluing, painting etc.) or subtractive- manufacturing process (e.g. milling, cutting, grinding, de-burring, polishing etc.). Also the industrial robot controller has good capability of I/O communication and often acts as cell controller in a typical set-up of a flexible manufacturing cell or system. Until now, driven by the need from the car manufactures, material handling and welding has been the most focused area of industrial robot development. [1]

It has been reported that material handling and the additive processes of welding counted for 80% of the industrial robot based applications in 2003, but foresees an extension into subtractive manufacturing applications. It has also been predicted that a lightweight type robot, capable of both subtractive and additive manufacturing, will have an impact on the car industry and the Small and Medium Sized

Enterprises (SMEs).

In the past, factory production lines were automated for mass production, and many industrial robots and specialized machines were introduced. Recently, flexible manufacturing systems, such as the cell production system (unlike in the line production method, an entire product is assembled by one worker), are being introduced in an increasing number of production sites in order to deal with differentiation of products and to meet diversified needs. However, many of the tasks in flexible manufacturing systems rely heavily on workers because the number of parts to be handled is larger so the time and costs required to switch product types on robots and specialized machines is greater.

Robots are valued in industry for the usual qualities of machines: untiring availability, predictability, reliability, precision and (relative) imperviousness to hostile environments. They do not, as yet, possess several important capabilities which come naturally to humans: the ability to react to unforeseen circumstances or changing environments, and the ability to improve performance based on prior experience. State-of-the art robots (mostly in, research labs) do have crude senses of "sight" and "touch", and limited capability to coordinate their manipulators with sensory input. Because of current limitations, today's robots are usefully employed in highly structured industrial environments where practically all of the variability and decision making can be engineered out of the workplace. Existing uses of industrial robots all involve repetitive pre-programmable tasks such as spot welding, spray painting, palletizing, and the loading and

unloading of many types of metal forming and metal cutting machines. The next generation of sensor based robots will be able to perform a broader range of tasks under less structured conditions, in addition to becoming cheaper and easier to use. Expected uses of robots with vision and improved feedback control will include inspection, assembly, heat treatment, grinding and buffing, and electroplating. [1]

## **2.2 Classification of Robots**

The most commonly used robot configurations are articulated robots, SCARA robots, Delta robots and Cartesian coordinate robots, (aka gantry robots or x-y-z robots). In the context of general robotics, most types of robots would fall into the category of robotic arms. Robots exhibit varying degrees of autonomy:

-Some robots are programmed to faithfully carry out specific actions over and over again (repetitive actions) without variation and with a high degree of accuracy. These actions are determined by programmed routines that specify the direction, acceleration, velocity, deceleration, and distance of a series of coordinated motions.

Other robots are much more flexible as to the orientation of the object on which they are operating or even the task that has to be performed on the object itself, which the robot may even need to identify. For example, for more precise guidance, robots often contain machine vision sub-systems acting as their "eyes", linked to powerful computers or controllers. Artificial intelligence, or what passes for it, is becoming an increasingly important factor in the modern industrial robot [9].

## 2.2.1 Cartesian robots

Cartesian robots, sometimes called gantry robots, are mechatronic devices that use motors and linear actuators to position a tool. They make linear movements in three axes, X, Y, and Z. Physical scaffolding forms a framework that anchors and supports the axes and payload. Certain applications, such as machining tightly toleranced parts, require full support of the base axis, usually the X axis. In contrast, other applications, such as picking bottles off a conveyor, require less precision, so the framework only needs to support the base axis in compliance with the actuator's manufacturer recommendations. Cartesian-robot movements stay within the framework's confines, but the framework can be mounted horizontally or vertically, or even overhead in certain gantry configurations. CNC machines (Figure 2.1) and 3D printing are famous application for this type.



Figure 2.1: CNC machine

## 2.2.2 SCARA robot

SCARAs and six-axis robots typically mount on a pedestal. SCARAs move in the X, Y, and Z planes like Cartesians, but incorporate a theta axis at the end of the Z plane to rotate the end-of-arm tooling. This makes SCARAs good for vertical assembly operations, such as inserting pins in holes without binding. However, the arm is essentially a lever, and that limits SCARAs' reach: The joints are load points that need robust bearings and high-torque motors to handle the loads when the arm extends. In Figure 2.2 an example of a SCARA robot.

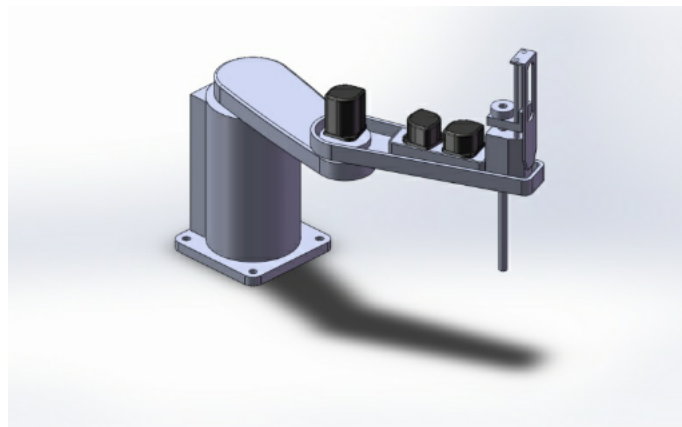

Figure 2.2: SCARA robot

## 2.2.3 Parallel robot “delta robot”

A delta robot is a parallel-link robot in which its major mechanical axes act on the robot faceplate in parallel rather than in series. This allows for both quick and precise movements. Delta robots are now being used extensively in assembly or other applications in which high-speed and repetition must be achieved simultaneously. The Figure 2.3 shows a delta robot.

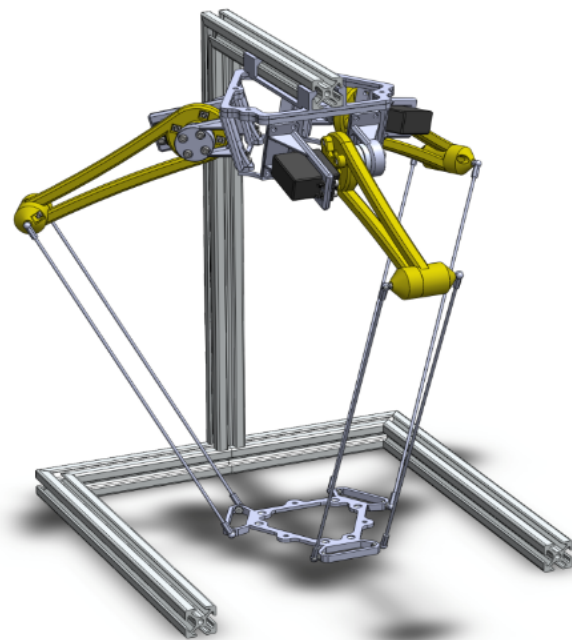

Figure 2.3: Delta robot

#### **2.2.4 Articulated robot**

An articulated robot (Figure 2.4) is a robot which is fitted with rotary joints. Rotary joints allow a full range of motion, as they rotate through multiple planes, and they increase the capabilities of the robot considerably. An articulated robot can have one or more rotary joints, and other types of joints may be used as well, depending on the design of the robot and its intended function. With rotary joints, a robot can engage in very precise movements. Articulated robots commonly show up on manufacturing lines, where they utilize their flexibility to bend in a variety of directions. Multiple arms can be used for greater control or to conduct multiple tasks at once, for example, and rotary joints allow robots to do things like turning back and forth between different work areas.





Figure 2.4: Six axes articulated robot

### **2.2.5 Cylindrical robot**

This robot has at least one rotary joint at the base and at least one prismatic joint to connect the links. The rotary joint uses a rotational motion along the joint axis, while the prismatic joint moves in a linear motion. Cylindrical robots operate within a cylindrical-shaped work envelope as shown in Figure 2.5. A cylindrical robotic system has three axes of motion – the circular motion axis and the two linear axes in the horizontal and vertical movement of the arm. While many people will compare a cylindrical robot to a SCARA robot because of their similar work envelope, the applications that a cylindrical robotic system can provide are vastly different from a SCARA. Because it can be combined with tooling, cylindrical robots are able to perform handling and assembly, as well as tasks like spot welding.

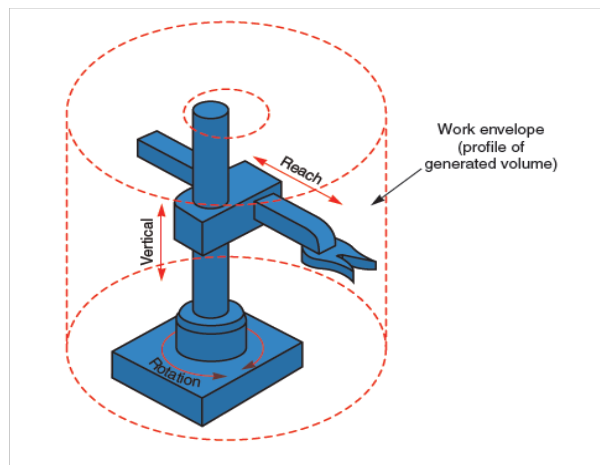

Figure 2.5: Cylindrical robot

## 2.2.6 Spherical “polar” robot

Polar also called spherical robots, in this configuration the arm is connected to the base with a twisting joint and a combination of two rotary joints and one linear joint. The axes form a polar coordinate system and create a spherical-shaped work envelope as shown in figure 2.6. So, these robots are more sophisticated than Cartesian and cylindrical robots, while control solutions are less complicated than those of articulated robot arms. This may be the reason why sometimes they are used as a base for robot kinematics exercises. Also, it should be noted that spherical robot type takes a significant spot in robot history, as some of the first robot arms can be counted into this type. Modern industrial robot arms kind of evolved from spherical robots and are sometimes regarded as this type, as their work envelope often is sphere-like as well. [4]

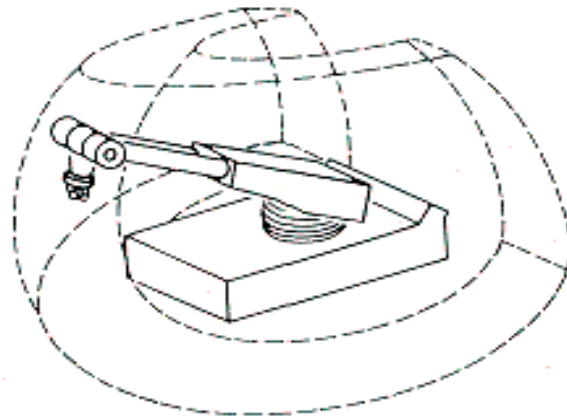

Figure 2.6: Polar robot

## 2.3 Robot Development

George Devol and Joseph Engelberger developed first industrial robot in 1959. It weighed two tons and was controlled by a program on a magnetic drum. They used hydraulic actuators and were programmed in joint coordinates, i.e. the angles of the various joints were stored during a teaching phase and replayed in operation. Unimation, USA, installed the first industrial robot at General Motor in 1961. The world's first industrial robot was used on a production line at the GM Ternstedt plant in Trenton, NJ, which made door and window handles, gearshift knobs, light fixtures and other hardware for automotive interiors. Obeying step-by-step commands stored on a magnetic drum.

The first cylindrical robot, the Versatran was installed by American Machine and Foundry (AMF) in 1962 at the Ford factory in Canton, USA. It was named the Versatran from the words versatile transfer. GM installed the first spot-welding robots at its Lordstown assembly plant in 1969. The Unimation robots boosted productivity and allowed more

than 90 percent of body welding operations to be automated vs. only 20 percent to 40 percent at traditional plants, where welding was a manual, dirty and dangerous task dominated by large jigs and fixtures. Trallfa, Norway, offers the first commercial painting robot in 1969. The robots were developed for in-house use in 1967 to spray paint wheelbarrows during a Norwegian labor shortage. KUKA moves from using Unimate robots to developing their own robots in 1973. Their robot, the Famulus was the first robot to have six electromechanically driven axes. Hitachi, Japan, developed the automatic bolting robot for concrete pile and pole industry in 1973. This robot was the first industrial robot with dynamic vision sensors for moving objects.

It recognized bolts on a mold while it is moving and fastened/loosened the bolts in synchronization with the mold motion. The first commercially available minicomputer-controlled industrial robot was developed by Richard Hohn in 1974 for Cincinnati Milacron Corporation. The robot was called the T3, The Tomorrow Tool. Kawasaki, Japan, developed a version of the Unimate to be used for spot-welding, fabricating Kawasaki motorcycle frames in 1974. They also added touch and force-sensing capabilities in their Hi-T-Hand robot, enabling the robot to guide pins into holes at a rate of one second per pin. The Olivetti –SIGMA|| a Cartesian-coordinate robot was one of the first used in Italy for assembly operations with two hands in 1975. Programmable Universal Machine for Assembly (PUMA) was developed in 1978 by Unimation/Vicarm, USA, with support from General Motors. The PUMA was adapted to GM specifications for a small parts handling line robot that maintained the

same space intrusion of a human operator.<sup>1</sup>Hiroshi Makino, University of Yamanashi, Japan, developed the SCARA-Robot (Selective Compliance Assembly Robot Arm) in 1978. By virtue of the SCARA's parallel axis joint layout, the arm is slightly compliant in the X-Y direction but rigid in the  $Z'$  direction.

KUKA, Germany, introduces a new Z-shaped robot arm whose design ignores the traditional parallelogram in 1985. It achieves total flexibility with three translational and three rotational movements for a total of six degrees of freedom. Demarex, Switzerland, sold its first Delta robot packaging application to Roland in 1992. Programmable Universal Machine for Assembly (PUMA) was developed in 1978 by Unimation/Vicarm, USA, with support from General Motors. The PUMA was adapted to GM specifications for a small parts handling line robot that maintained the same space intrusion of a human operator.<sup>1</sup>Hiroshi Makino, University of Yamanashi, Japan, developed the SCARA-Robot (Selective Compliance Assembly Robot Arm) in 1978. By virtue of the SCARA's parallel axis joint layout, the arm is slightly compliant in the X-Y direction but rigid in the Z direction.

KUKA, Germany, introduces a new Z-shaped robot arm whose design ignores the traditional parallelogram in 1985. It achieves total flexibility with three translational and three rotational movements for a total of six degrees of freedom. Demarex, Switzerland, sold its first Delta robot packaging application to Roland in 1992.

The first application was a landmark installation of 6 robots loading pretzels into blister trays. It was based on the delta robot developed by Raymond Clavel, Federal Institute of Technology of Lausanne (EPFL).

ABB, Sweden, developed the Flex Picker, the world's fastest picking robot based on the delta robot developed by Raymond Clavel, Federal Institute of Technology of Lausanne (EPFL) in 1998. It was able to pick 120 objects a minute or pick and release at a speed of 10 meters per second, using image technology. Reis, Germany, introduces integrated laser beam guiding within the robot arm and launches the RV6L-CO2 laser robot model in 1999. This technology replaces the need of an external beam guiding device thus allowing using laser in combination with a robot at high dynamics and no collision contours. Motoman, Japan, introduced the improved robot control system (NX100) which provided the synchronized control of four robots, up to 38 axes in 2004. Comau, Italy, introduced the first Wireless Teach Pendant (WiTP) in 2006. All the traditional data communication/robot programming activities can be carried out without the restrictions caused by the cable connected to the Control Unit, but at the same time absolute safety is ensured.

KUKA, Germany, presents the first –Light Weight Robot|| in 2006. It was developed in cooperation with DLR, Institute of Robotics and Mechatronic, Germany, the outer structure of the KUKA lightweight robot is made of aluminum. It ideally suited to handling and assembly tasks. Fanuc, Japan, launched the first –Learning Control Robot|| in 2010. FANUC's Learning Vibration Control (LVC) allows the robot to learn its vibration characteristics for higher accelerations and speeds. Learning control reduces the cycle time of the robot motion by suppressing the vibration of the robot arm [7].

Robotics has made several advancements throughout the years and

one of those is the development of humanoid robots. Humanoid robots imitate human form through perception, processing, and action. Humanoid robotics was developed for the interaction with human beings among their environments and tools. These human robots can match the physical, cognitive, and social aspects of people, making them capable of the same tasks as humans. Today, robotics affects a broad sector of economic activities from automotive and electronics industries to food, recycling, logistics, etc.

## **2.4 Industrial Robot Components**

There are three basic components of industrial robot: Manipulator, Controller and Tooling.

### **2.4.1 Manipulator**

It consists of the base and arm of the robot, including the power supply, which may be electrical, hydraulic or pneumatic. The manipulator is the device that provides movement in any number of degrees of freedom. The movement of manipulator can be described in relation to its coordinate system, which may be cylindrical, spherical, anthropomorphic or Cartesian. Depending on controller, movement can be point-to-point or continuous-path motion.

### **2.4.2 Controller**

The versatility of a robot arises from its multi-axis mechanical configuration

and the robot controller. The ability to reprogram the robot controller gives the flexibility to the robot to perform a wide range of actions.

The controller contains various interfaces with both command devices and sensing units. The controller has to define the trajectory of the

robot gripper with time and transform this trajectory, which is in Cartesian coordinates, into its base-frame coordinate system and finally into joint movements. Many of these tasks are to be performed in real time. Several easy-to-use robot programming languages such as VAL, MCL and APT are available.

### **2.4.3 Tooling**

Tooling is what enables the robot to do a particular job. Tooling is sometimes used synonymously with end effectors, although the latter has a more restricted meaning to apply to end-of-arm fixturing to grasp, lift or turn. Tooling on the other hand, has a broader context which can apply to power tools for drilling and grinding, as well as for painting and welding guns. Typical end effectors include electromagnets, hooks, vacuum cups, adhesive fingers and bayonet sockets. There are six basic motions or degrees of freedom, which provide the robot the capability to move the end effectors through the required sequence of motions. The six motions consist of three arm and body motions and three gripper motions. The three arms and body motions consist of vertical traverse, radial traverse and rotational traverse. The gripper motions are yaw, pitch and roll

## **2.5 Industrial Robot Applications**

Industrial robots have a wide range of potential applications in manufacturing systems because they are flexible and programmable themselves. The use of sensors allows the robots to see, hear and smell the environment.

### **2.5.1 Welding**



Robot welding is commonly used for resistance spot welding and arc welding in high production application, such as the automotive industry.

### **2.5.2 Pick and place**

Robotic pick and place automation speed up the process of picking parts up and placing them in new locations, increasing production rates.

### **2.5.3 Packing and labeling**

Packaging robots are extremely flexible; with the right end of arm tooling a robot can complete any packaging process. There are large variety of robot sizes, mounting options, payload and reach to choose from.

### **2.5.4 Painting**

Robot painting produces top quality results. Once properly programmed and industrial painting robot can apply material without leaving behind drips, inconsistencies, overspray, etc. Industrial painting robots can provide exceptional part accessibility, not only are robotic arms slim and far –reaching, but can be installed in a number of different locations allowing for even greater flexibility. Robotic painters also protect workers .the painting application is a hazardous taxing job, workers can be exposed to unsafe fumes from the paint.

## **2.6 Benefits of Industrial Robots**

Many benefits of robots seem to be most noticeable in productivity, safety, and in saving time and money.

### **2.6.1 Productivity**

- Robots produce more accurate and high quality work.
- Robots rarely make mistakes and are more precise than human workers.
- They can produce a greater quantity in a short amount of time.
- They can work at a constant speed with no breaks, days off, or holiday time.
- They can perform applications with more repeatability than humans

### **2.6.2 Safety**

- Robots save workers from performing dangerous tasks.
- They can work in hazardous conditions, such as poor lighting, toxic chemicals, or tight spaces.
- They are capable of lifting heavy loads without injury or tiring.
- Robots increase worker safety by preventing accidents since humans are not performing risky jobs.

### **2.6.3 Savings**

- Robots save time by being able to produce a greater magnitude of products.
- They also reduce the amount of wasted material used due to their accuracy.
- Robots save companies money in the long run with quick ROIs (return on investment), fewer worker injuries (reducing or eliminating worker's comp), and with using less materials. The list of the advantages of robots does not end there; they have also created jobs for workers. Many people believe the misconception that robots have taken away jobs from workers, but that is not necessarily true. Robots have created new jobs for those who were once on production lines

with programming. They have pulled employees from repetitive, monotonous jobs and put them in better, more challenging ones. Today robots are user-friendly, intelligent, and affordable. The benefits of robots continue to grow as more industries incorporate them.

## **2.7 Conclusion**

This chapter has introduced the concept of a system in which industrial robots were applied to picking work, medium payload handling work, assembly work, and showed the different types of industrial robot arms and their various applications.

# **Chapter Three**

## **Robot main components**

### **3.1 Introduction**

The main components of the project are the servo motor as the manipulator, Arduino as the controller, and the sensor.

### **3.2 Servo Motor**

Servo motor is a type of motors whose output shaft can be moved to a specific angular position by sending it a coded signal. The servo motor will maintain the position of the shaft as long as you keep applying the coded signal. When you change the coded signal, the angular position of the shaft will change. It is just made up of simple motor which run through servo mechanism. If motor is used is DC powered then it is called DC servo motor, and if it is AC powered motor then it is called AC servo motor. We can get a very high torque servo motor in a small and light weight packages. Doe to these features they are being used in many applications like toy car, RC helicopters and planes, Robotics, Machine etc.

### **3.2.1 Servo mechanism**

It consists of three parts:

1. Controlled device.
2. Output sensor.
3. Feedback system.

It is a closed loop system where it uses positive feedback system to control motion and final position of the shaft. Here the device is controlled by a feedback signal generated by comparing output signal and reference input signal.

Here reference input signal is compared to reference output signal and the third signal is produces byfeedback system. And this third signal acts as input signal to control device. This signal is present as long as feedback signal is generated or there is difference between reference input signal and reference output signal. So the main task of servomechanism is to maintain output of a system at desired value at

presence of noises.

### **3.2.2 Working principle of servo motors**

A servo consists of a motor (DC or AC), a potentiometer, gear assembly and a controlling circuit. First of all we use gear assembly to reduce RPM and to increase torque of motor. Say at initial position of servo motor shaft, the position of the potentiometer knob is such that there is no electrical signal generated at the output port of the potentiometer. Now an electrical signal is given to another input terminal of the error detector amplifier. Now difference between these two signals, one comes from potentiometer and another comes from other source, will be processed in feedback mechanism and output will be provided in term of error signal. This error signal acts as the input for motor and motor starts rotating. Now motor shaft is connected with potentiometer and as motor rotates so the potentiometer and it will generate a signal.

So as the potentiometer's angular position changes, its output feedback signal changes. After sometime the position of potentiometer reaches at a position that the output of potentiometer is same as external signal provided. At this condition, there will be no output signal from the amplifier to the motor input as there is no difference between external applied signal and the signal generated at potentiometer, and in this situation motor stops rotating.

### **3.2.3 Controlling servo motor**

Servo motor is controlled by Pulse width Modulation (PWM) which is provided by the control wires. There is a minimum pulse, a maximum pulse and a repetition rate. Servo motor can turn 90 degree from either

direction from its neutral position. The servo motor expects to see a pulse every 20 milliseconds (ms) and the length of the pulse will determine how far the motor turns. For example, a 1.5ms pulse will make the motor turn to the 90° position, such as if pulse is shorter than 1.5ms shaft moves to 0° and if it is longer than 1.5ms than it will turn the servo to 180°. Servo motor works on PWM (Pulse width modulation) principle (see figure 3.1). Means its angle of rotation is controlled by the duration of applied pulse to its Control PIN. Basically servo motor is made up of DC motor which is controlled by a variable resistor (potentiometer) and some gears, high speed force of DC motor is converted into torque by Gears.

$$\text{WORK} = \text{FORCE} * \text{DISTANCE} \quad (3.1)$$

In DC motor Force is less and distance (speed) is high and in Servo, force is high and distance is less, potentiometer is connected to the output shaft of the Servo, to calculate the angle and stop the DC motor on required angle.

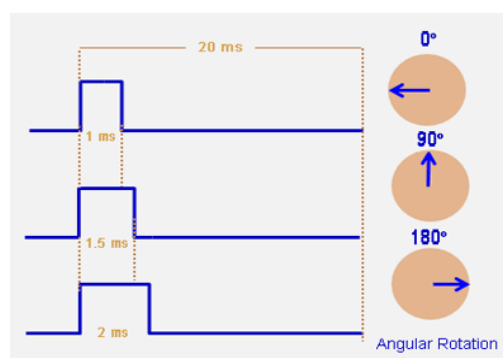

Figure 3.1: PWM (pulse Width Modulation)

### 3.2.4 Types of servo motor

Servo motors are classified into different types based on their

application, such as AC servo motor, DC servo motor, brushless DC servo motor, positional rotation, continuous rotation and linear servo motor etc. Typical servo motors comprise of three wires namely, power control and ground. The shape and size of these motors depend on their applications. RC servo motor is the most common type of servo motor used in hobby applications, robotics due to their simplicity, affordability and reliability of control by microprocessors

#### (DC servo motor

The motor which is used as a DC servo motor generally have a separate DC source in the field of winding & armature winding. The control can be archived either by controlling the armature current or field current. Field control includes some particular advantages over armature control. In the same way armature control includes some advantages over field control. Based on the applications the control should be applied to the DC servo motor. DC servo motor provides very accurate and also fast respond to start or stop command signals due to the low armature inductive reactance. DC servo motors are used in similar equipments and computerized numerically controlled machines.

#### (AC servo motor

AC servo motor is an AC motor that includes encoder is used with controllers for giving closed loop control and feedback. This motor can be placed to high accuracy and also controlled precisely as compulsory for the applications. Frequently these motors have higher designs of tolerance or better bearings and some simple designs also use higher voltages in order to accomplish greater torque.

Applications of an AC motor mainly involve in automation, robotics, CNC machinery, and other applications a high level of precision and needful versatility.

#### (Positional rotation servo motor

Positional rotation servo motor is a most common type of servo motor. The shaft's output rotates in about 180 degree. It includes physical stops located in the gear mechanism to stop turning outside these limits to guard the rotation sensor. These common servos involve in radio controlled water, radio controlled cars, aircraft, robots, toys and many other applications.

#### (Continuous rotation servo motor

Continuous rotation servo motor is quite related to the common positional rotation servo motor, but it can go in any direction indefinitely. The control signal, rather than set the static position of the servo, is understood as the speed and direction of rotation. The range of potential commands sources the servo to rotate clockwise or anticlockwise as preferred, at changing speed, depending on the command signal. This type of motor is used in radar.

#### (Linear servo motor

Linear servo motor is also similar the positional rotation servo motor is discussed above, but with an extra gears to alter the o/p from circular to back-and-forth. These servo motors are not simple to find, but sometimes you can find them at hobby stores where they are used as actuators in higher model airplanes.[11]

### **3.3 Arduino**



Arduino is an open-source platform used for building electronics projects.

Arduino consists of both a physical programmable circuit board (often referred to as a microcontroller) and a piece of software, or IDE (Integrated Development Environment) that runs on your computer, used to write and upload computer code to the physical board. The Arduino platform has become quite popular with people just starting out with electronics, and for good reason. Unlike most previous programmable circuit boards, the Arduino does not need a separate piece of hardware (called a programmer) in order to load new code onto the board you can simply use a USB cable. Additionally, the Arduino IDE uses a simplified version of C++, making it easier to learn to program. Finally, Arduino provides a standard form factor that breaks out the functions of the micro-controller into a more accessible package. Figure 3.1 show Arduino Uno microcontroller

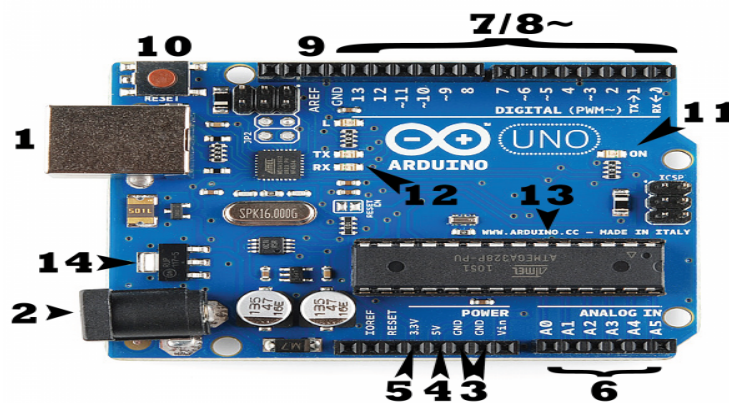

Figure 3.1: Arduino Uno

### 3.3.1 Hardware and board component

There are many varieties of Arduino boards that can be used for

different purposes. Some boards look a bit different from the one in figure 3.2, but most Arduinos have the majority of these components in common:

### (Power (USB / barrel jack))

Every Arduino board needs a way to be connected to a power source. The Arduino UNO can be powered from a USB cable coming from your computer or a wall power supply (like this) that is terminated in a barrel jack. In the picture above the USB connection is labeled (1) and the barrel jack is labeled (2). The USB connection is also how you will load code onto your Arduino board. More on how to program with Arduino can be found in our Installing and Programming Arduino tutorial.

### (Pins (5V, 3.3V, GND, Analog, Digital, PWM, AREF)).

(GND (3): Short for 'Ground'. There are several GND pins on the Arduino, any of which can be used to ground your circuit.

(5V (4) & 3.3V (5): As you might guess, the 5V pin supplies 5 volts of power, and the 3.3V pin supplies 3.3 volts of power. Most of the simple components used with the Arduino run happily off of 5 or 3.3 volts.

(Analog (6): The area of pins under the 'Analog In' label (A0 through A5 on the UNO) is Analog In pins. These pins can read the signal from an analog sensor (like a temperature sensor) and convert it into a digital value that we can read.

(Digital (7): Across from the analog pins are the digital pins (0 through 13 on the UNO). These pins can be used for both digital input (like telling

if a button is pushed) and digital output (like powering an LED).

(PWM (8): You may have noticed the tilde (~) next to some of the digital pins (3, 5, 6, 9, 10, and 11 on the UNO). These pins act as normal digital pins, but can also be used for something called Pulse-Width Modulation (PWM) think of these pins as being able to simulate analog output (like fading an LED in and out).

(AREF (9): Stands for Analog Reference. Most of the time you can leave this pin alone. It is sometimes used to set an external reference voltage (between 0 and 5 Volts) as the upper limit for the analog input pins.

(Reset button

Just like the original Nintendo, the Arduino has a reset button(10).Pushing it will temporarily connect the reset pin to ground and restart any code that is loaded on the Arduino. This can be very useful if your code doesn't repeat, but you want to test it multiple times. Unlike the original Nintendo however, blowing on the Arduino doesn't usually fix any problems.

(Power LED indicator

Just beneath and to the right of the word "UNO" on your circuit board, there's a tiny LED next to the word 'ON' (11). This LED should light up whenever you plug your Arduino into a power source. If this light doesn't turn on, there's a good chance something is wrong. Time to re-check your circuit!

(TX RX LEDs

TX is short for transmit, RX is short for receive. These markings appear quite a bit in electronics to indicate the pins responsible for

serial communication. In our case, there are two places on the Arduino UNO where TX and RX appear – once by digital pins 0 and 1, and a second time next to the TX and RX indicator LEDs **(12)**. These LEDs will give us some nice visual indications whenever our Arduino is receiving or transmitting data (like when we're loading a new program onto the board).

### (Main IC

The black thing with all the metal legs is an IC, or Integrated Circuit **(13)**. Think of it as the brains of our Arduino. The main IC on the Arduino is slightly different from board type to board type, but is usually from the ATmega line of IC's from the ATMEL Company. This can be important, as you may need to know the IC type (along with your board type) before loading up a new program from the Arduino software. This information can usually be found in writing on the top side of the IC. If you want to know more about the difference between various IC's, reading the datasheets is often a good idea.

### (Voltage Regulator

The voltage regulator **(14)** is not actually something you can (or should) interact with on the Arduino. But it is potentially useful to know that it is there and what it's for. The voltage regulator does exactly what it says – it controls the amount of voltage that is let into the Arduino board. Think of it as a kind of gatekeeper; it will turn away an extra voltage that might harm the circuit. Of course, it has its limits, so don't hook up your Arduino to anything greater than 20 volts.

## **3.3.2 Software and Arduino IDE**

The Arduino project provides the Arduino Integrated Development environment (IDE), which is a cross-platform application written in the programming language Java. It originated from the IDE for the languages Processing and Wiring. It is designed to introduce programming to artists and other newcomers unfamiliar with software development. It includes a code editor with features such as syntax highlighting, brace matching, and automatic indentation, and provides simple one-click mechanism to compile and load programs to an Arduino board. A program written with the IDE for Arduino is called a "sketch".

The Arduino IDE supports the languages C and C++ using special rules to organize code. The Arduino IDE supplies a software library called Wiring from the Wiring project, which provides many common input and output procedures. A typical Arduino C/C++ sketch consists of two functions that are compiled and linked with a program stub `main ()` into an executable cyclic executive program:

`Setup()`: a function that runs once at the start of a program and that can initialize settings.

`loop()`: a function called repeatedly until the board powers off.

After compiling and linking with the GNU tool chain, also included with the IDE distribution, the Arduino IDE employs the program `avrdude` to convert the executable code into a text file in hexadecimal coding that is loaded into the Arduino board by a loader program in the board's firmware.[8]

### **3.4 Sensors**

A sensor is a device which is capable of converting any physical

quantity to be measured into a signal which can be read, displayed, stored or used to control some other quantity. This signal produced by the sensor is equivalent to the quantity to be measured. Sensors are used to measure a particular characteristic of any object or device. For example a thermocouple, a thermocouple will sense heat energy (temperature) at one of its junction and produce equivalent output voltage which can be measured by a voltage read by the voltmeter. All sensors need to be calibrated with respect with some reference value or standard device for accurate measurement. Sensors are classified based on the nature of quantity they measure. Following are some types of sensors with few examples:

### **3.4.1 Photo resistor**

Photo resistors, also known as light dependent resistors (LDR), are light sensitive devices most often used to indicate the presence or absence of light, or to measure the light intensity. In the dark, their resistance is very high, sometimes up to  $1\text{M}\Omega$ , but when the LDR sensor is exposed to light, the resistance drops dramatically, even down to a few ohms, depending on the light intensity. LDRs have a sensitivity that varies with the wavelength of the light applied and are nonlinear devices. They are used in many applications but are sometimes made obsolete by other devices such as photodiodes and phototransistors. Some countries have banned LDRs made of lead or cadmium over environmental safety concerns.

### **3.4.2 Light dependant resistor**

A light dependant resistor also know as a LDR, photo resistor, photoconductor, photocell, is a resistor whose resistance increases or

decreases depending on the amount of light intensity. Light Dependant Resistors(LDR) are a very useful tool in a light/dark circuits. A LDRs can have a variety of resistance and functions. For example it can be used to turn on a light when the LDR is in darkness or to turn on a light when the LDR is in light. It can also work the other way around, so when the LDR is in light it turns on the circuit and when it's in darkness the resistance increase and disrupts the circuit. The vast majority of LDRs are made from cadmium-sulfate (CdS), and they are very cheap, but also not very accurate. They are very good for detecting changes in light levels and determining if it is 'dark' or 'light', but without individual calibration they are not suitable for accurately measuring light levels.

### **3.4.3 CdS photocell**

Pictured below is a typical light dependent resistor. It has two wire leads which terminate in the face of the light detector – the two metal dots you see are the ends of those electrodes. The main body of the light detector component is made of ceramic – an excellent insulator. On the face of the ceramic a thin strip of cadmium sulfate is coated in a Zig-Zag pattern (to maximize the length of the strip while keeping the component small) which is connected at each end to an electrode. The front face is then coated in clear plastic, epoxy, glass, or similar. Figure 3.2 shows the LDR sensor.

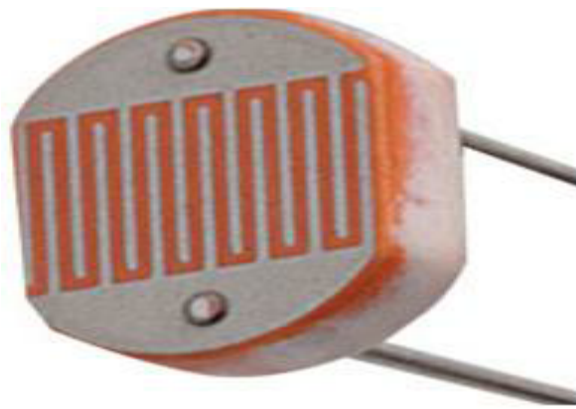

Figure 3.2: LDR sensor

Cadmium-sulfate is a high resistance semiconductor, and is chosen for light detectors as it gives the same spectral response as the human eye it responds to the same range of wavelengths of light that we can see. Specifically, cadmium-sulfate is a photoconductive material. That means that photons of light hitting it with sufficient energy will release electrons from their atomic bonds.

When a negatively charged electron is freed by a photon of light, it leaves behind a positively charged 'hole'. When a voltage is applied across the two wire leads of the light detector, the free electron moves one way along the CdS strip, and the free 'hole' moves the other way; and it is this movement of charge which is electricity flowing through the light detector. The higher the light intensity, the more photons of light are hitting the CdS strip, the more electron-hole pairs are generated, the more electricity can flow through the light detector, and so the lower the resistance of the light detector (i.e. it is easier for electricity to flow through the light detector when the light intensity hitting it is high).

#### **3.4.4 Light dependent resistor circuits**



There are two basic circuits using light dependent resistors the first is activated by darkness (Figure 3.3), the second is activated by light (Figure 3.4). The two circuits are very similar and just require an LDR, some standard resistors, a variable resistor (aka potentiometer), and any small signal transistor.

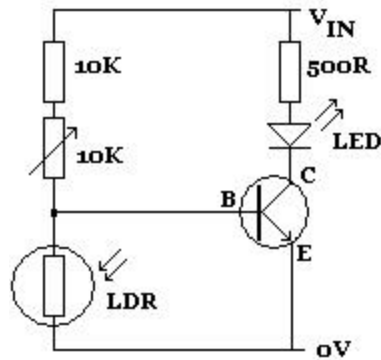

Figure 3.3: LDR circuit activated by darkness.

In the circuit diagram above, the LED lights up whenever the LDR is in darkness. The 10K variable resistor is used to fine-tune the level of darkness required before the LED lights up. The 10K standard resistor can be changed as required to achieve the desired effect, although any replacement must be at least 1K to protect the transistor from being damaged by excessive current.

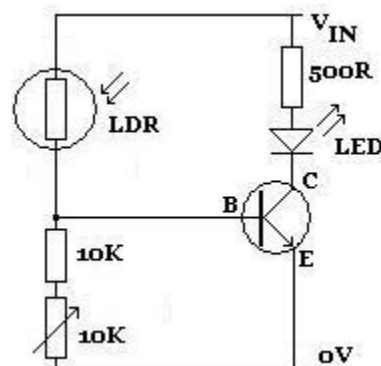

Figure 3.4: LDR circuit activated by light

By swapping the LDR over with the 10K and 10K variable resistors (as shown above), the circuit will be activated instead by light. Whenever sufficient light falls on the LDR (manually fine-tuned using the 10K variable resistor), the LED will light up. [13]

### **3.4 Belt Conveyor**

A conveyor belt is the carrying medium of a belt conveyor system (often shortened to belt conveyor). A belt conveyor system is one of many types of conveyor systems. A belt conveyor system consists of two or more pulleys (sometimes referred to as drums), with an endless loop of carrying medium—the conveyor belt—that rotates about them. One or both of the pulleys are powered, moving the belt and the material on the belt forward. The powered pulley is called the drive pulley while the unpowered pulley is called the idler pulley. There are two main industrial classes of belt conveyors; Those in general material handling such as those moving boxes along inside a factory and bulk material handling such as those used to transport large volumes of resources and agricultural materials, such as grain, salt, coal, ore, sand, overburden and more.

Today there are different types of conveyor belts that have been created for conveying different kinds of material available in PVC and rubber materials. The belt consists of one or more layers of material. Many belts in general material handling have two layers. An under layer of material to provide linear strength and shape called a carcass and an over layer called the cover. The carcass is often a woven fabric having a warp & weft. The most common carcass materials are

polyester, nylon and cotton. The cover is often various rubber or plastic compounds specified by use of the belt. Covers can be made from more exotic materials for unusual applications such as silicone for heat or gum rubber when traction is essential.

Material flowing over the belt may be weighed in transit using a beltweigher. Belts with regularly spaced partitions, known as elevator belts, are used for transporting loose materials up steep inclines. Belt Conveyors are used in self-unloading bulk freighters and in live bottom trucks. Belt conveyor technology is also used in conveyor transport such as moving sidewalks or escalators, as well as on many manufacturing assembly lines. Stores often have conveyor belts at the check-out counter to move shopping items. Ski areas also use conveyor belts to transport skiers up the hill.

The main type of conveyers are:

1. slider bed

This type consists of a smooth surface usually made from steel. However,

sometimes the surface can be made from Masonite. The belt is fixed to the surface to facilitate transportation of items or goods. (See figure 3.5)



Figure 3.5: slider bed

## 2. Roller bed

As the name suggests, in this type of belt conveyor, the surface for the belt comprises of rollers. The rollers are selected based on the load of the items to be transported and the required speed of the belt. Usually there are two rollers in a short belt conveyor. However, the number of rollers may increase if the distance between the two ends of the belt conveyor is more. Typically, these belt conveyors are used when the items are loaded onto it with gravity rather than manually. Manual loading can cause mechanical shock to the rollers, resulting in damage. (See figure 3.6).

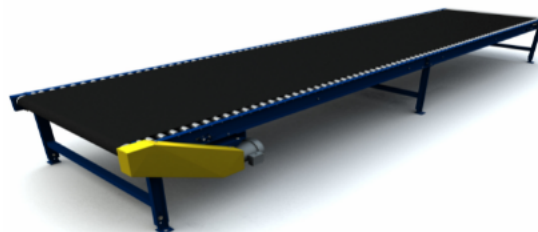

Figure 3.6: Roller bed

### 3.Horizontal belt conveyor

This type of belt conveyor consists of a center drive, gear motor, and take-up. Based on the drive of the conveyor, it can come with one or two pulleys at the end. The belt of the conveyor is flexible and the entire system has floor supports along its length. (See figure 3.7).

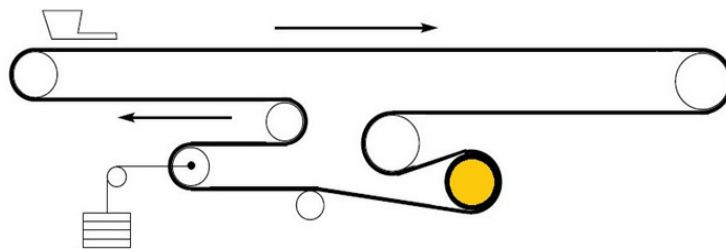

Figure 3.7: Horizontal belt conveyor

### 4.Incline and Decline Conveyor

This type of conveyor is similar to a horizontal belt conveyor, but has an additional component. It comes with a single or double nose over and sometimes it also has a feeder portion. Typically, this type of conveyor has a rough surface on the belt during incline or decline rather than making use of a smooth-surfaced belt. This offers more traction to the items placed on the conveyor and prevents them from rolling backwards or forwards. ( See figure 3.8).



Figure 3.8: Incline and decline conveyer

### 5.Brake and meter belt conveyor

This conveyor comprises of two parts. The brake belt is installed at the end of the conveyor and facilitates accumulation of the items, while the meter belt is used to separate items. Typically, the meter belt has the drive, whereas the brake belt uses the slave drive from the meter belt. The length of the brake and meter belt is very important. Typically, it should be about 1/7th of the total length of the accumulation conveyor and this includes brake and meter belt lengths too.( See Figure 3.8).

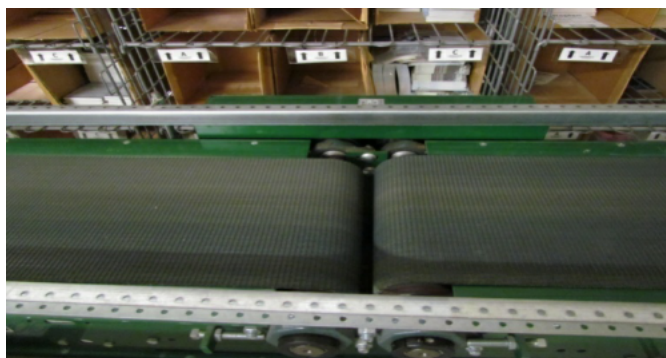

Figure 3.8: Brake and meter belt conveyor

## 6. Metal “piano hinge” conveyor

This is a hinged type belt conveyor made from steel. It is perfect for transporting hot and oily components from a punch press and forging machines. This type of belt conveyor can be horizontal, inclined into an ‘S’ shape or even level. ( See figure 3.9).



Figure 3.9: Metal “piano hinge” conveyor

## 7. Wire mesh belt conveyor

As the name suggests, it has mesh that will facilitate air ventilation. Hence, this type of belt conveyor is ideal for transporting hot and cold items or components that cannot be handled using standard duck or PVC belts. The wire mesh is placed on roller or longitudinal runners and then it is covered with a thick plastic. In addition, there are toothed pulleys to clasp onto the wire mesh belt. (See figure 3.10).



Figure 3.10: Wire mesh belt conveyor

### 8.Portable Conveyor

This conveyor comes with caster wheels allowing it to be rolled from one place to another. There are different types of portable conveyors and most companies can find one to suit their needs. There are even portable gravity conveyors that can be extended depending on the customer's needs. (See figure 3.11).



Figure 3.11: Portable conveyor



# Chapter four

## Design and Implementation

### 4.1. Introduction

The main focus of this work was to design, develop and implementation of competitively robot arm with enhanced control and stumpy cost. The robot arm was designed with four degrees of freedom and talented to accomplish accurately simple tasks, such as light material handling, which will be integrated into a mobile platform that serves as an assistant for industrial workforce. The robot arm is equipped with several servo motors which do links between arms and perform arm movements. The servo motors include encoder so that no controller was implemented. To control the robot we used Arduino, which performs inverse kinematic calculations and communicates the proper angles serially to a microcontroller that drives the servo motors with the capability of modifying position, speed and acceleration. Testing and validation of the robot arm was carried out and results shows that it work properly.

The mechanical design of the robot arm is based on a robot manipulator with similar functions to a human arm. The links of such a manipulator are connected by joints allowing rotational motion and the links of the manipulator is considered to form a kinematic chain. The business end of the kinematic chain of the manipulator is called the end effector or end-of-arm-tooling and it is analogous to the human hand. Figure 4.1 shows the Free Body Diagram for mechanical

design of the robotic arm. As shown, the end effector is not included in the design because a commercially available gripper is used. This is because that the end effector is one of the most complex parts of the system and, in turn, it is much easier and economical to use a commercial one than build it.

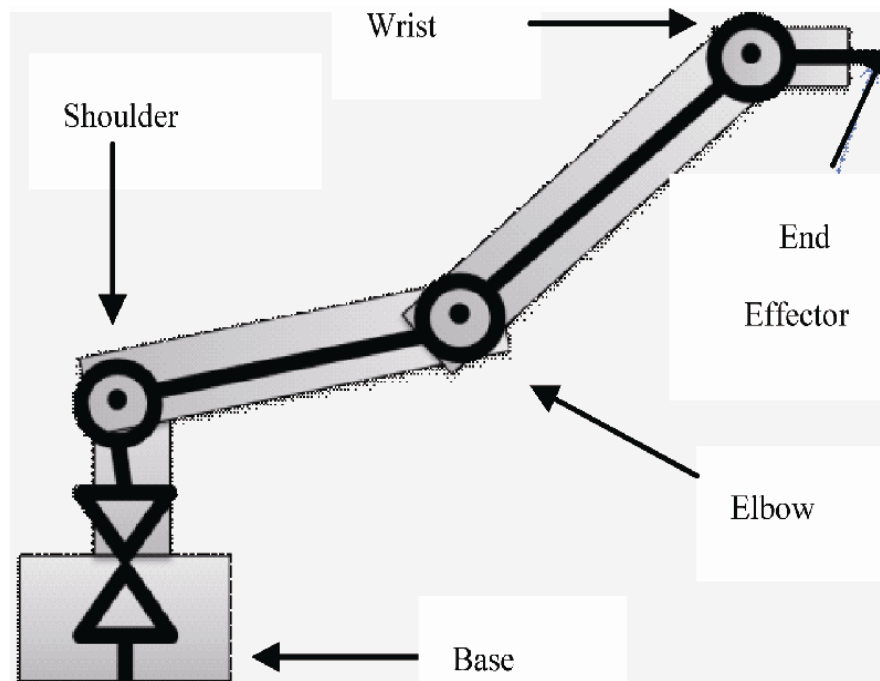

Figure 4.1: Free body diagram of the robot arm

Figure 4.2 shows the work region of the robotic arm. This is the typical workspace of a robot arm with four degree of freedom (4 DOF). The mechanical design was limited to 4 DOF mainly because that such a design allows most of the necessary movements and keeps the costs and the complexity of the robot competitively. Accordingly, rotational motion of the joints is restricted where rotation is done around two axes in the shoulder and around only one in the elbow and the wrist. (See Figure 4.1).

The robot arm joints are typically actuated by electrical motors. The

servo motors were chosen, since they include encoders which automatically provide feedback to the motors and adjust the position accordingly. However, the disadvantage of these motors is that rotation range is less than 180° span, which greatly decreases the region reached by the arm and the possible positions. The qualifications of servo motors were selected based on the maximum torque required by the structure and possible loads. In the current study, the material used for the structure was acrylic.

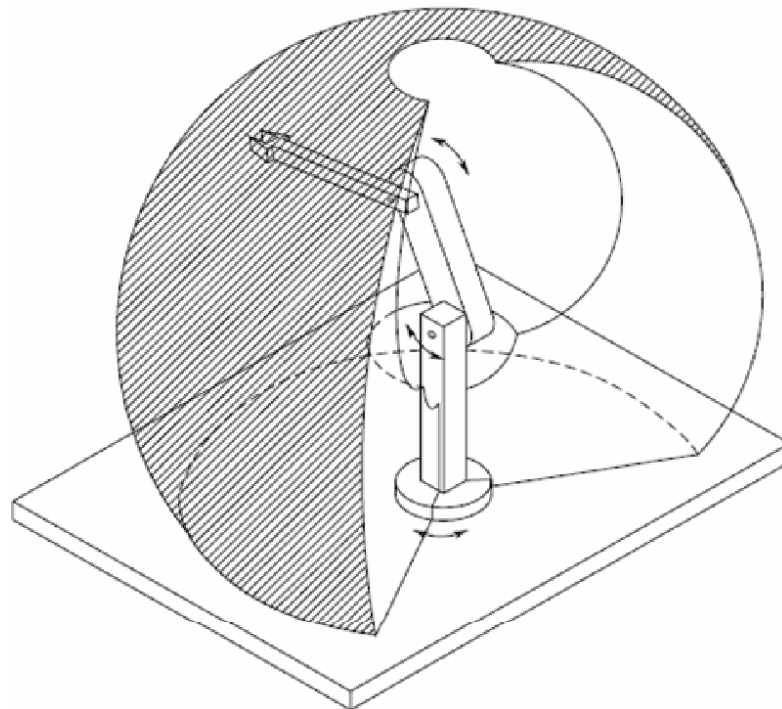

Figure 4.2: Work region of the robotic arm.

## 4.2 Block Diagram

Figure 4.3 show the block diagram of the project.

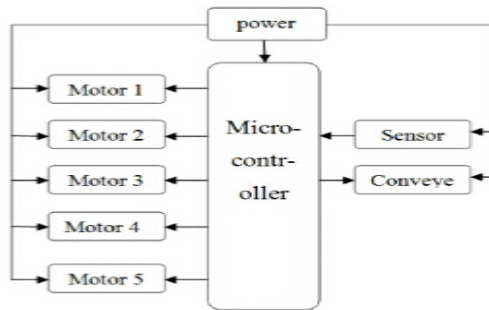

Figure 4.3 : Block Diagram of robotic arm.

The block diagram of our project is as shown above. The different components involved in our project are:

### 4.2.1. Microcontroller

It is used to controls the motor activation and deactivation operations and also reads sensor signals.

### 4.2.2. Motors

An electric motor is an electromechanical device that converts electrical energy into mechanical energy. Electric motors can be powered by direct current sources, such as from batteries. Microcontrollers command these motors through the driver circuit to take the necessary action. D. POWER SUPPLY a regulated power supply is an embedded circuit, the function of which is to supply a stable voltage, to a circuit or device that must be operated within certain power supply limits. This is used to supply the power to the microcontroller and the driver circuits.

### 4.2.3 Obstacles sensor

This sensor is used to detect the obstacles while carrying out the task. LDR sensor is used to sense the obstacles in the front.

#### 4.2.4. Power supply

A regulated power supply is an embedded circuit, the function of which is to supply a stable voltage, to a circuit or device that must be operated within certain power supply limits. This is used to supply the power to the microcontroller and the motors.

### 4.3. Mechanical Calculation

#### 4.3.1. Force and torque calculation

Figure 4.3 shows the force diagram used for load calculations. The calculations were carried out only for the joints that have the largest loads, since the other joints would have the same motor, i.e. the motor can move the links without problems. The calculations considered the weight of the motors, about 50 grams, except for the weight of motor at joint B, since it is carried out by link BA. Figure 4 shows the force diagram on link CB, which contains the joints (B and C) with the highest load (carry the links DC and ED) and the calculations are carried out as follows.

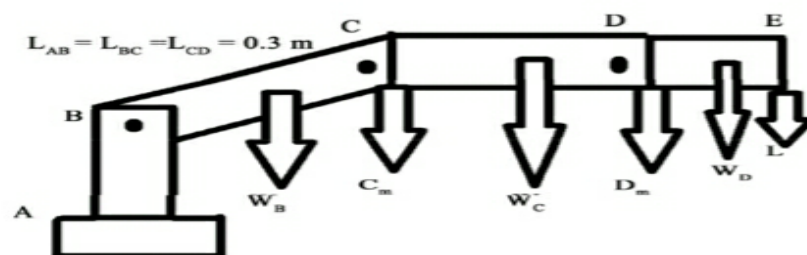

Figure 4.3: Force diagram of robot arm.

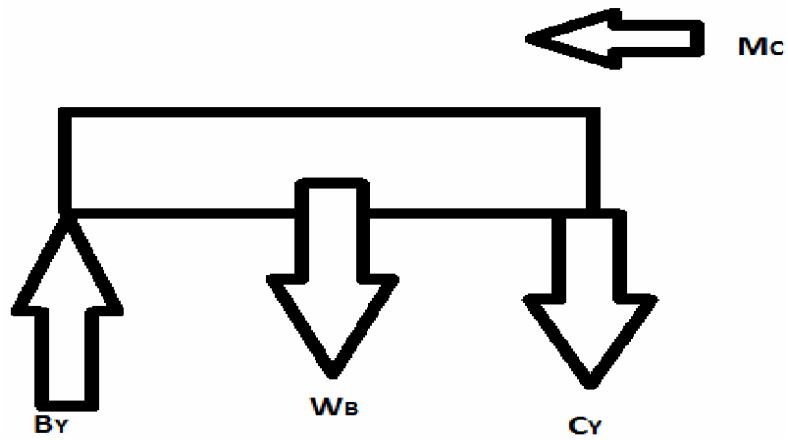

Figure 4.4: Force diagram of link CB.

The values used for the torque calculations:

$W_d = 0.011$  kg (weight of link DE)

$W_c = 0.030$  kg (weight of link CD)

$W_b = 0.030$  kg (weight of link CB)

$L = 1$  kg (load)

$C_m = D_m = 0.050$  kg (weight of motor)

$L_{BC} = 0.14$  m (length of link BC)

$L_{CD} = 0.14$  m (length of link CD)

$L_{DE} = 0.05$  m (length of link DE)

Performing the sum of forces in the Y axis, using the loads as shown in Figure 4, and solving for  $C_Y$  and  $C_B$ , see Equations (1)-(4). Similarly, performing the sum of moments around point C, Equation (5), and point B, Equation (6), to obtain the torque in C and B, Equations (7) and (8), respectively.

$$\sum F_y = (L + W_D + D_M + W_C + C_M) g - DC_Y = 0 \quad (4.1)$$

$$C_Y = (1.141 \text{ kg}) * 9.8 \text{ m/s}^2 = 11.18 \text{ N}$$

(4.2)

$$\sum F_y = (L + W_D + D_M + W_C + C_M + W_B) g - C_B = 0 \quad (4.3)$$

$$C_B = (1.171\text{kg}) * 9.8 \text{ m/s}^2 = 11.4758 \text{ N}$$

(4.4)

$$\sum M_C = - (W_C * L_{CD}) / 2W_D(L_{CD} + L_{DE}/2) \quad (4.5)$$

$$-L(L_{CD} + L_{DE}) - D_M(L_{CD}) + M_C = 0$$

$$\sum M_B = -L(L_{BC} + L_{CD} + L_{DE}) - W_D(L_{BC} + L_{DC} + L_{DE}/2) - D_M(L_{BC} + L_{CD}) - W_C(L_{BC} + L_{CD}/2) - C_M(L_{BC}) - W_B * L_{BC}/2 + M_B = 0 \quad (4.6)$$

$$M_C = 1.968 \text{ Nm} \quad (4.7)$$

$$M_B = 3.554 \text{ Nm} \quad (4.8)$$

The servo motor that was selected, based on the calculations, is the TOWARDPRO MG996R, which has a torque of 2Nm this motor was recommended because it is much cheaper than any other motor with same specifications. Since we need more torque at joint B, see Equation (8), we used spring at point B to comply with the torque requirements; however, one motor is enough for the other joints. Using spring with the motor at joint B is much cheaper than using one big motor with 3.554Nm .

## 4.4 Design

The design of the model consists of three parts, the robotic arm, controlling unit, the conveyor. These three parts are working together simultaneously to pack the product after being manufactured and sealed into the boxes in the order that the manufacturer desires. All of the parts of the model will work together when the operator starts the system, no part will operate individually. The design of each of the arm, controlling unit and the conveyor will be specified as follow:

### 4.4.1 The arm design

It consists of:

1. Five servo motors.
2. Aluminum links.
3. End effector (Gripper).

Four motors are toggled in the aluminum links as the body of the arm; the reason of choosing the aluminum because of its lightweight and strength, the lighter the body is the more less load the motors will bear. Every motor is attached to two pieces of the aluminum links; one carries the upper part and the other is toggled to the lower part, except of lowest motor and the gripper, every motors -except the lowest- are supported in the aluminum link attached with the lower motor, and the shaft of the motor is connected to the link holding the upper motor, all of them are connected in same way to the last one which hold the gripper directly without an aluminum link. The degree of freedom, or DOF, is a very important term to understand. Each degree of freedom is a joint on the arm, a place where it can bend or rotate or translate. You can typically identify the number of degree of freedom by the number of actuators on the robot arm. Now this is very important- when building a robotic arm you need as few degrees of freedom allowed for the application; because each degree of freedom requires a motor, and that exponentially the cost.

In this model there are four degrees of freedom, and five actuators (servo motors) -the fifth motor is in the last effector (the gripper) - one based in the link, two holding the arm and one holding the gripper. These four degrees of freedom make controlling the arm more accurate and complicated, but it make the movement of the arm in the arm WORKSPACE freer than the three degree of freedom or two



degree of freedom. The workspace or sometimes known as reachable space is all places that the end effector (gripper) can reach. The workspace is dependent on the DOF angle/translation limitations, the arm link strength, the angle at which something must be picked up at, etc. The workspace is highly dependent on the arm configuration. The end effector in this project is a gripper, this gripper acts like the fingers of a human hand. The actuator of the gripper is a servo motor linked with a gear that causes the movement of the fingers of the gripper. The gear transfer the rotation of the motor to linear movement, when the motor rotate in the clockwise the two parts of the gripper opens, and when it rotate anti clockwise the two parts closes. So controlling the gripper is by controlling the angle of the servo motor using the microcontroller.

#### **4.4.2 Conveyor design**

The conveyor consists of:

1. 360° servo motor.
2. 4 holders.
3. Leather belt.
4. Sensor.
5. 2 bars

The four holder are attached to the billet two in the front and two in the back, the bars are installed in the holders and the leather belt are roped between them. The motor is attached to one of the bars.

#### **4.4.3 Control unit**

The control unit is the board that control the robotic arm, and it consist of the microcontroller and the sensor. The microcontroller that

used in this project is ArduinoUno the Arduino controls the motors in the arm and the motor that controls the conveyor using the switches and the sensor.

The servo motor has three pins, the red and the black pins are for the power and the yellow one is for the signal, this signal pin is connected directly to one of PWM (pulse width modulation) pins as an output from the microcontroller.

The controlling of each motor in the arm is achieved by a program stored in the memory of the microcontroller. This program sets the angle of the servo motor to move the arm to the desired point in the workspace. The motor of the conveyor will be working until the sensor sends a signal to the microcontroller and the microcontroller will send a signal to the motor to stop working, once the obstacle is gone the motor will resume working again.

## **4.5 Procedure**

Once the system start operating the motor of the conveyor will start working and the belt will move with the product on it to the arm, then the product cuts the leaser from the LDR and the LDR resistance will change and the Arduino will send a signal to the motor to stop working. In meanwhile the arm will move to the position of the product according to the program that saved in the Arduino and adjust the angles of the servo motors to go to the exact position of the object that been needed to pick. Each angle of the movement of the arm has been calculated for each motor.

When the arm reaches the product and pick it, it will start moving to the position where it should place the product on it. After the arm take

the product the sensor will send a signal to the Arduino and the motor of the conveyor will start working again carrying another product. And the arm will go back to pick the other product.

## **Chapter Five**

### **Conclusion and Recommendations**

#### **5.1 Conclusion**

Industrial robotic arms have become essential in all modern industries, and in this project a simple model of industrial robotic arm had designed and implemented to do a specific task repetitively. Also showed how the real robotic arms in industry are being controlled and designed, to conclude every industrial robotic arm consists of three main parts; the actuator, the controller and the end effector and they are connected together and programmed according to the type of work that needs to be executed.

## 5.2 Recommendations

We recommend improving the system stability and efficiency by using PID or compensator, and using more accurate sensors to detect the objects. And programming the arm to sorting the products according to their colors or sizeect.

And also you can use intelligent control like fuzzy control or artificial neural networks to make the arm do more complicated tasks

## REFERENCES

- [1] Solvang, B.; Sziebig, G. & Korondi, P. –Multilevel Control of Flexible Manufacturing Systems||, Proceedings of IEEE Conference on Human System Interactions (HSI'08), pp.785–790, ISBN 1-4244- 1543-8, May. 2008.
- [2] Zhang, H.; Wang, J.; Zhang, G.; Gan, Z.; Pan, Z.; Cui, H. & Zhu, Z. – Machining with flexible manipulator: toward improving robotic machining performance||, Proceedings of IEEE/ASME International Conference on Advanced Intelligent Mechatronics, pp. 1127-1132, ISBN 0-7803-9047-4, July 2005.
- [3] Brogårdh T. –Present and future robot control development– An industrial Perspective||. Annual Reviews in Control, Vol. 31, No. 1, pp. 69-79, 2007.
- [4] ONO Kazuya, HAYASHI Toshihiro, FUJII Masakazu, SHIBASAKI Nobuhiro, SONEHARA Mitsuharu, –Development for Industrial Robotics Application|| Journal of –IHI Engineering Review|| Vol. 42, No. 2, pp. 103-107, 2009.
- [5] James S. Albus. –Industrial Robots and Productivity improvement|| in Technical Report, industrial Systems Division, National Bureau of Standards, October, 1981.
- [6] Robert U. Ayres and Steve M. Miller.||Preparing for the Growth of industrial Robots|| Technical Report Policy Paper 3, Robot Institute of America, May, 1981.
- [7] –Milestones in the History of Industrial Robots|| Compiled by International Federation of Robotics 2012.
- [8] Mikell P. Groover, –Automation, Production System and Computer-

- [9] Balkeshwar Singh. –Role of Industrial Robots in Lean Manufacturing System|| Journal of –International Journal of Scientific Research Engineering & Technology (IJSRET)|| Vol.1, Issue3, pp 150-153, August 2012.
- [10] Max A. Denket‘Frontiers in Robotics Research’. Nova Publishers.(2006).
- [11] RiazollahFiroozian ‘Servo Motors and Industrial Control Theory’2009.
- [12] George W. YOUNKIN‘Industrial Servo Control Systems’ Fundamentals and Applications 2002.
- [13] Sensors and Actuators: Engineering System Instrumentation, Second Edition by Clarence W. de Silva.