

CHAPTER ONE

INTRODUCTION

1.1 Overview:

Stepper motors find several applications in varying fields such as robotics, computer peripherals, business machines, machine tools etc. Off late, the use of stepper motors has seen a surge mainly attributed to their precision, robustness, reliability, smaller size and lower cost. Stepper motors were originally designed to be used in open loop control. Their inherent stepping ability allows for accurate positioning without feedback. However, they show a poor performance with respect to very precise motion control and high dynamic requirements.

Closed loop control of stepper motors has been increasingly employed to achieve faster response times and higher resolution capabilities. One of these applications of stepper motors is sun tracking System.

The sun is a low cost source of electricity for instead of using generators, solar panel can convert direct sun rays to electricity. Conventional solar panel, fixed with a certain angle, limits their area of exposure from the sun due to rotation of the earth. Output of the solar cells depends on the intensity of the sun and the angle of incidence.

In pursuing to get the maximum energy converted from the sun, an automated system is required which should be capable to constantly rotate the solar panel. The Automatic Sun Tracking System (ASTS) is a project meant to solve this problem. It is completely automatic and keeps the panel parallel to the sun.

The ASTS takes the sun as a guiding source. Sensors are used to constantly monitor the sunlight and rotate the solar panel to the maximum intensity of sunlight. Arduino UNO controller and light independent resistors (LDR) are used as a device for controlling the output for the motor. [1,5]

1.2 Problem Statement:

This work is mainly focused on position control of permanent magnet stepper motors using sensors feedback for closed loop control .So dependent light resistors (LDR) are used to estimate the states of the motor instead of light intensity to determine the position of the stepper motor of sun tracking system according to sun position.

1.3 Project Objectives:

The main objectives of the project are:

To study the theory of operation of stepper motors.

To investigate the position control of stepper motor using Arduino controller

To apply the position control of stepper motor in sun tracking system

1.4 Methodology:

To achieve research project the following methodology is used:

Study and understand the operation theory of stepper motors

Contract the simulation model of sun tracking system using proteus software.

Evaluate the performance of solar tracking system based on simulation results.

1.5 Project Layout:

This project is presented in five chapters. The scope of each chapter is explained as follows: Chapter one gives an introduction including general concepts, problem statement, objectives and methodology .Chapter two presents stepper motor fundamentals, types of stepper motors, theory of operation and open loop control of each type and its applications. Chapter three introduces the solar tracking system and control system its benefits, types of solar tracking system. Chapter four includes the design of single axis solar tracker system, simulation, results and discussion. Chapter five contains the conclusion and recommendations.

CHAPTER TWO

STEPPER MOTOR FUNDAMENTALS

2.1 Stepper Motor:

These motors are also called stepping motors or step motors. The name stepper is used because this motor rotates through a fixed angular step in response to each input current pulse received by its controller. In recent years, there has been widespread demand of stepping motors because of the explosive growth of the computer industry. Their popularity is due to the fact that they can be controlled directly by computers, microprocessors and programmable controllers. Industrial motors are used to convert electric energy into mechanical energy but they cannot be used for precision positioning of an object or precision control of speed without using closed-loop feedback. Stepping motors are ideally suited for situations where either precise positioning or precise speed control or both are required in automation systems. The unique feature of a stepper motor is that its output shaft rotates in a series of discrete angular intervals or steps, one step being taken each time a command pulse is received. When a definite number of pulses are supplied, the shaft turns through a definite known angle. This fact makes the motor well-suited for open-loop position control because no feedback need be taken from the output shaft. Such motors develop torques ranging from 1 $\mu\text{N}\cdot\text{m}$ up to 40 $\text{N}\cdot\text{m}$ in a motor of 15 cm diameter suitable for machine tool applications. Their power output ranges from about 1 W to a maximum of 2500 W. The only moving part in a stepping motor is its rotor which has no windings, commutator or brushes. Step Angle the angle through which the motor shaft rotates for each command pulse is called the step angle (β). [5]

Smaller the step angle, greater the number of steps per revolution and higher the resolution or accuracy of positioning obtained. The step angles can be as small as 0.72° or as large as 90° . But the most common step sizes are 1.8° , 2.5° , 7.5° and 15° . The value of step angle can be expressed either in terms of the rotor and stator poles (teeth) N_r and N_s respectively or in terms of the number of stator phases (m) and the number of rotor teeth. [5]

$$\beta = \frac{N_s - N_r}{N_s * N_r} * 360 \quad (2.1)$$

$$\beta = \frac{360}{m * N_r} = \frac{360}{\text{No.of stator phases} * \text{No.of rotor teeth}} \quad (2.2)$$

Resolution is given by the number of steps needed to complete one revolution of the rotor shaft. Higher the resolution, greater the accuracy of positioning of objects by the motor.

$$\text{Resolution} = \text{No.of steps /revolution} = 360/\beta \quad (2.3)$$

A stepping motor has the extraordinary ability to operate at very high stepping rates (up to 20,000 steps per second in some motors) and yet to remain fully in synchronism with the command pulses. When the pulse rate is high, the shaft rotation seems continuous. Operation at high speeds is called ‘slewing’. When in the slewing range, the motor generally emits an audible whine having a fundamental frequency equal to the stepping rate. If f is the stepping frequency (or pulse rate) in pulses per second (PPS) and β is the step angle, then motor shaft speed is given by

$$n = \beta * f / 360 \text{ rps} \quad (2.4)$$

2.2 Applications:

Computer controlled stepper motors are a type of motion-control positioning system. They are typically digitally controlled as part of an open loop system for use in holding or positioning applications.

In the field of lasers and optics they are frequently used in precision positioning equipment such as linear actuators, linear stages, rotation stages, goniometers, and mirror mounts. Other uses are in packaging machinery, and positioning of valve pilot stages for fluid control systems.

Commercially, stepper motors are used in floppy disk drives, flatbed scanners, computer printers, plotters, slot machines, image scanners, compact disc drives, intelligent lighting, camera lenses, CNC machines and, more recently, in 3D printers.

Here are some applications of stepper motors:

- 1- Operation control in computer peripherals.
- 2- Textile industry.
- 3- IC fabrications and robotics.
- 4- Applications requiring incremental motion are typewriters, line printers, tape drives, floppy disk drives, numerically-controlled machine tools, process control systems and X-Y plotters.
- 5- Stepper motors also perform countless tasks outside the computer industry. It includes commercial, military and medical applications where these motors perform such functions as mixing, cutting, striking, metering, blending and purging. Usually, position information can be obtained simply by keeping count of the pulses sent to the motor thereby eliminating the need for expensive position sensors and feedback controls.

2.3 Types of Stepper Motors:

There are three basic categories: [1, 5]

(i) Variable Reluctance Stepper Motor:

It has wound stator poles but the rotor poles are made of a ferromagnetic material. It can be of the single stack type or multi-stack type which gives smaller step angles. Direction of motor rotation is independent of the polarity of the stator current. It is called variable reluctance motor because the reluctance of the magnetic circuit formed by the rotor and stator teeth varies with the angular position of the rotor. As a variable speed machine, VR motor is sometime designed as switched-reluctance motor.

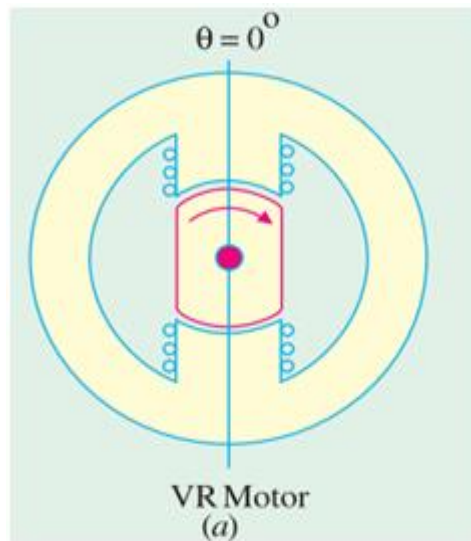

Figure 2.1 Variable Reluctance Stepper Motor

(ii) Permanent Magnet Stepper Motor:

It has wound stator poles but its rotor poles are permanently magnetized. The permanent magnet motor, also referred to as a "canstack" motor, has, as the name implies, a permanent magnet rotor. It is a relatively low speed, low torque device with large step angles of either 45 or 90 degrees. Its simple construction and low

cost make it an ideal choice for non-industrial applications, such as a line printer print wheel positioner. Similarly, PM stepper motor is also called variable speed brushless dc motor.

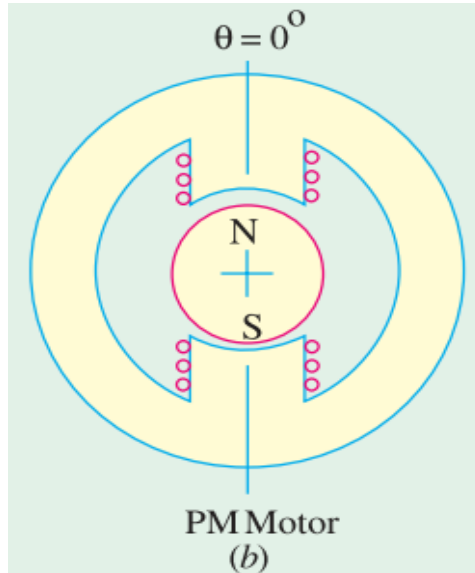

Figure 2.2 permanent magnet stepper motor

(iii) Hybrid Stepper Motor:

It has wound stator poles and permanently-magnetized rotor poles. It is best suited when small step angles of 1.8° , 2.5° etc. are required.

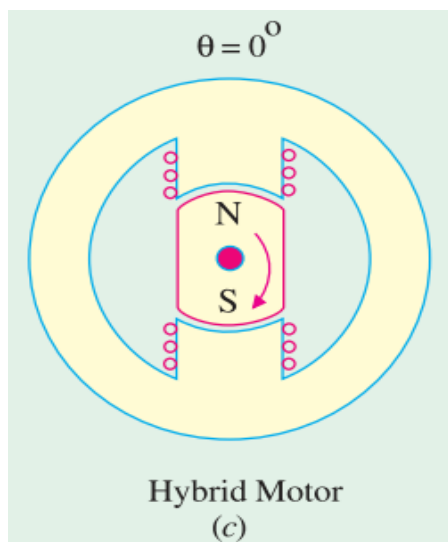

Figure 2.3 hybrid stepper motor

2.3.1 Variable Reluctance Stepper Motors:

A variable-reluctance motor is constructed from ferromagnetic material with salient poles as shown below.

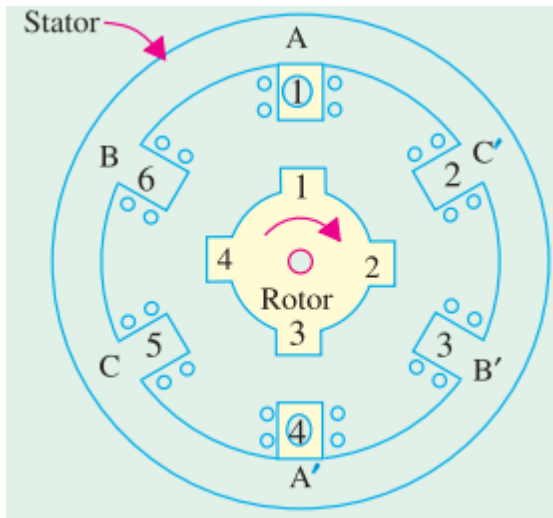

Figure 2.4 Variable Reluctance Stepper Motor construction

The stator is made from a stack of steel laminations and has six equally spaced projecting poles (or teeth) each wound with an exciting coil. As seen, there are three independent stator circuits or phases A, B and C and each one can be energized by a direct current pulse from the drive circuit.

The rotor which may be solid or laminated has four projecting teeth of the same width as the stator teeth. A simple circuit arrangement for supplying current to the stator coils in proper sequence is shown in Fig 2.5 (e). The six stator coils are connected in 2coil groups to form three separate circuits called phases. Each phase has its own independent switch. Diametrically opposite pairs of stator coils are connected in series such that when one tooth becomes a N-pole, the other one becomes a S-pole. Although shown as mechanical switches in Fig 2.5 (e), in actual practice, switching of phase currents is done with the help of solid-state control. When there is no current in the stator coils, the rotor is completely free to rotate.

Energizing one or more stator coils causes the rotor to step forward (or backward) to a position that forms a path of least reluctance with the magnetized stator teeth. The step angle of this three-phase, four rotor teeth motor is $\beta = 360 / 4 \times 3 = 30^\circ$.

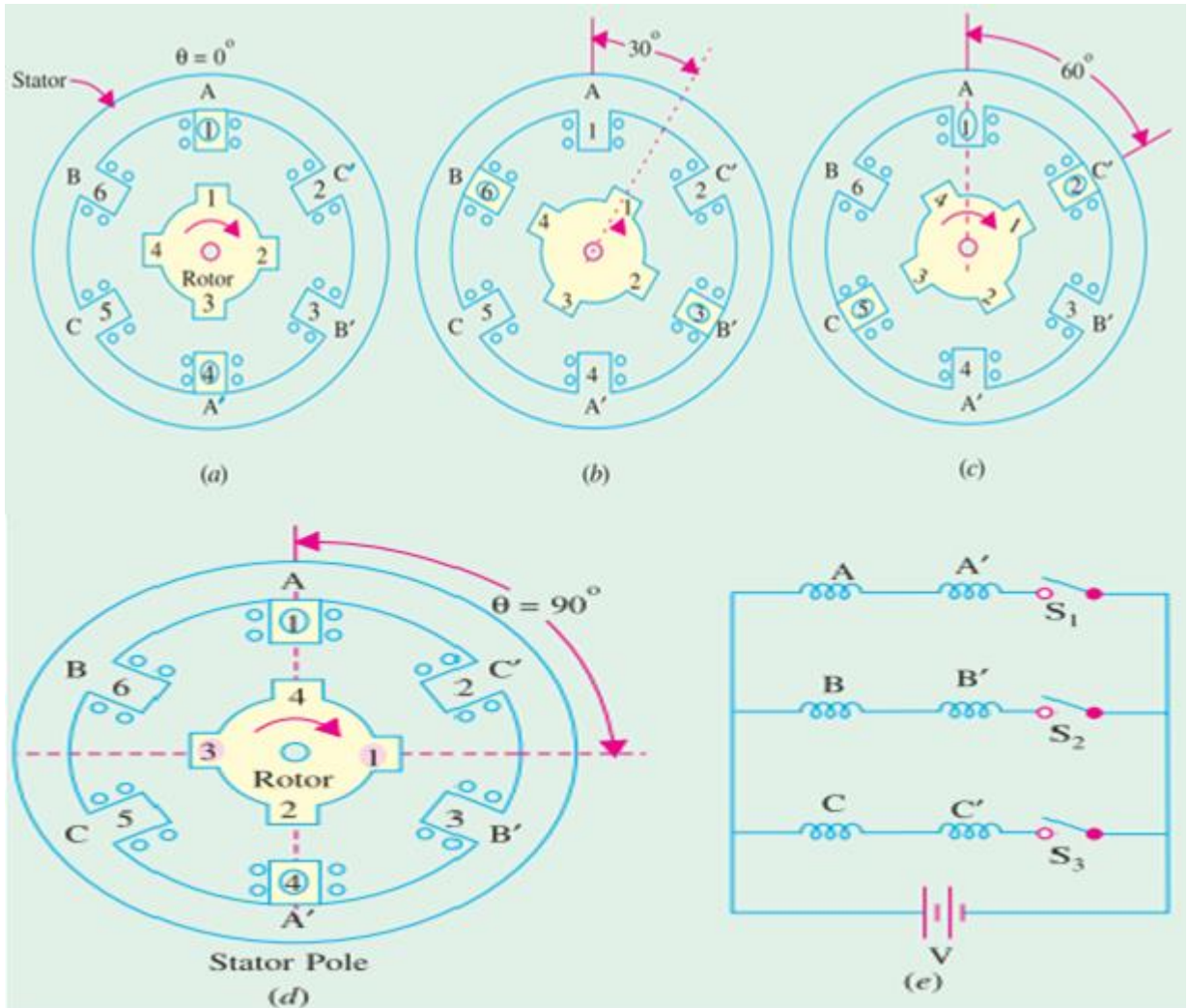

Figure 2.5 operation of Variable Reluctance Stepper Motor

2.2.1.1 Operation Modes:

The operation mode of stepper are summarized as follows:

I) one-phase-ON or Full-step Operation:

Fig 2.5 shows the position of the rotor when switch S1 has been closed for energizing phase A. A magnetic field with its axis along the stator poles of phase A is created. The rotor is therefore, attracted into a position of minimum reluctance with diametrically opposite rotor teeth 1 and 3 lining up with stator teeth 1 and 4 respectively. Closing S2 and opening S1 energizes phase B causing rotor teeth 2 and 4 to align with stator teeth 3 and 6 respectively as shown in Fig 2.5 (b). The rotor rotates through full-step of 30° in the clockwise (CW) direction. Similarly, when S3 is closed after opening S2, phase C is energized which causes rotor teeth 1 and 3 to line up with stator teeth 2 and 5 respectively as shown in Fig 2.5 (c), the rotor rotates through an additional angle of 30° in the clockwise (CW) direction. Next if S3 is opened and S1 is closed again, the rotor teeth 2 and 4 will align with stator teeth 4 and 1 respectively thereby making the rotor turn through a further angle of 30° as shown in Fig 2.5 (d). By now the total angle turned is 90° . As each switch is closed and the preceding one opened, the rotor each time rotates through an angle of 30° . By repetitively closing the switches in the sequence 1-2-3-1 and thus energizing stator phases in sequence ABCA etc., the rotor will rotate clockwise in 30° steps. If the switch sequence is made 3-2-1-3 which makes phase sequence CBAC (or ACB), the rotor will rotate anticlockwise. This mode of operation is known as 1-phase-ON mode or full-step operation and is the simplest and widely-used way of making the motor step. The stator phase switching truth table is shown in table 2.1. It may be noted that the direction of the stator magnetizing current is not significant because a stator pole of either magnetic polarity will always attract the rotor pole by inducing opposite polarity.

Table 2.1 one phase on mode (A, B, C, A)

A	B	C	β
+	0	0	0°
0	+	0	30°
0	0	+	60°
+	0	0	90°

II) 2-phase-ON Mode:

In this mode of operation, two stator phases are excited simultaneously. When phases A and B are energized together, the rotor experiences torques from both phases and comes to rest at a point mid-way between the two adjacent full-step positions. If the stator phases are switched in the sequence AB, BC, CA, AB etc., the motor will take full steps of 30° each (as in the 1phase-ON mode) but its equilibrium positions will be interleaved between the full-step positions. The phase switching truth table for this mode is shown below.

Table 2.2 2-phase-on mode

A	B	C	β
+	+	0	15°
0	+	+	45°
+	0	+	75°
+	+	0	105°

III) Half-step mode:

Half-step operation or ‘half-stepping’ can be obtained by exciting the three phases in the sequence A, AB, B, BC, C etc. i.e. alternately in the 1-phase-ON and 2-

phase-ON modes. It is sometime known as ‘wave’ excitation and it causes the rotor to advance in steps of 15° i.e. half the full-step angle. The truth table for the phase pulsing sequence is:

Table 2.3 half step mode

A	B	C	β
+	0	0	0°
+	+	0	15°
0	+	0	30°
0	+	+	45°
0	0	+	60°
+	0	+	75°
+	0	0	90°

Energizing only phase a causes the rotor position shown in Fig 2.6(a). Energizing phases A and B simultaneously moves the rotor to the position shown in Fig 2.6 (b) where rotor has moved through half a step only. Energizing only phase B moves the rotor through another half-step as shown in Fig 2.6 (c). With each pulse, the rotor moves $30 / 20 = 15^\circ$ in the CCW direction. It will be seen that in half-stepping mode, the step angle is halved thereby doubling the resolution. Moreover, continuous half-stepping produces a smoother shaft rotation.

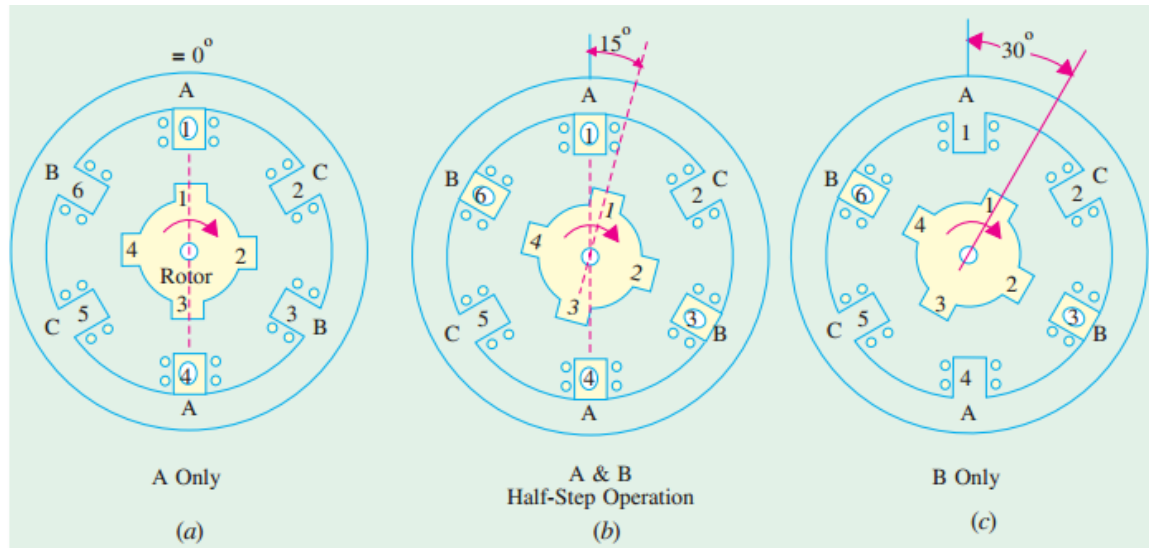

Figure 2.6 Half step mode

IV) Micro-stepping:

It utilized two phases simultaneously as in 2-phase ON mode but with the two currents deliberately unequal. The current in phase A is held constant while that in phase B is increase in very small increments until the maximum current is researched. The current in phase A is than decreased to zero with the same small increments. In this way the resultant steps becomes very small and is called a micro-stepping. Micro-stepping can divide a motor's basic step up to 256 times. Micro stepping improves low speed smoothness and minimizes low speed resonance effects. Micro-stepping produces roughly 30% less torque than two phase full stepping. Stepper motor employing micro-stepping is used in printing and phototypesetting where very fine resolution is required. As seen micro-stepping result in smooth low speed and high resolution.

2.3.2 Permanent-Magnet Stepping Motor:

Its stator construction is made of a permanent-magnet material like magnetically ‘hard’ ferrite. As shown in the Fig 2.7 (a), the stator has projecting poles but the rotor is cylindrical and has radially magnetized permanent magnets. The operating principle of such a motor can be understood with the help of Fig 2.7 (a) where the rotor has two poles and the stator has four poles. The step angle of this motor $\beta = 360^\circ / mNr = 360^\circ / 2 \times 2 = 90^\circ$ or $\beta = (4 - 2) \times 360^\circ / 2 \times 4 = 90^\circ$.

When a particular stator phase is energized, the rotor magnetic poles move into alignment with the excited stator poles. The stator windings A and B can be excited with either polarity current (A+ refers to positive current i_{A+} in the phase A and A- to negative current i_{A-}). Fig 2.7 (a) shows the condition when phase A is excited with positive current i_{A+} . Here, $\theta = 0^\circ$. If excitation is now switched to phase B as in Fig 2.7 (b), the rotor rotates by a full step of 90° in the clockwise direction. Next, when phase A is excited with negative current i_{A-} , the rotor turns through another 90° in CW direction as shown in Fig 2.7 (c). Similarly, excitation of phase B with i_{B-} further turns the rotor through another 90° in the same direction as shown in Fig 2.7 (d). After this, excitation of phase A with i_{A+} makes the rotor turn through one complete revolution of 360° . The direction of rotation depends on the polarity of the phase currents as tabulated below:

$i_{A+}; i_{B+}; i_{A-}; i_{B-}; i_{A+}, \dots$	
A ⁺ ; B ⁺ ; A ⁻ ; B ⁻ ; A ⁺ ,	For clockwise rotation
$i_{A+}; i_{B-}; i_{A-}; i_{B+}; i_{A+}, \dots$	
A ⁺ ; B ⁻ ; A ⁻ ; B ⁺ ; A ⁺ ,	For CCW rotation

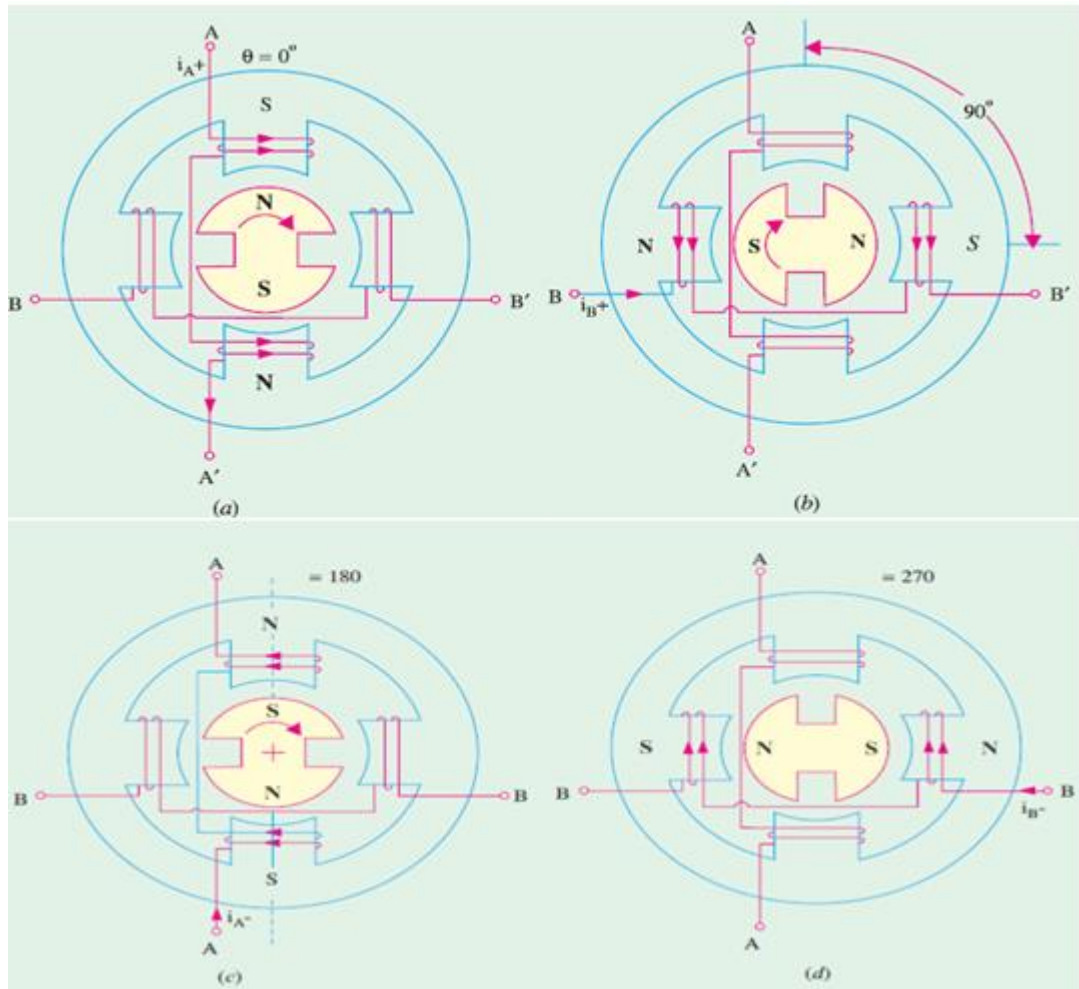

Figure 2.7 construction and operation modes of PM stepper motor

Table 2.4 operation modes

1- phase on			2- phase on			Half step		
A	B	β	A	B	β	A	B	β
+	0	0°	+	+	45°	+	0	0°
0	+	90°	-	+	135°	+	+	45°
-	0	180°	-	-	225°	0	+	90°
0	-	270°	+	-	315°	-	+	135°

2.3.3 Hybrid Stepper Motor:

It combines the features of the variable reluctance and permanent-magnet stepper motors. The rotor consists of a permanent magnet that is magnetized axially to create a pair of poles marked N and S in Fig 2.8. Two end caps are fitted at both ends of this axial magnet. These end-caps consist of equal number of teeth which are magnetized by the respective polarities of the axial magnet. The rotor teeth of one end-cap are offset by a half tooth pitch so that a tooth at one end-cap coincides with a slot at the other. The cross-sectional views perpendicular to the shaft along X-X' and Y -Y ' axes are shown in Fig 2.8. (a) and (c) respectively. As seen, the stator consists of four stator poles which are excited by two stator windings in pairs. The rotor has five N-poles at one end and five S-poles at the other end of the axial magnet. The step angle of such a motor is $= (5 - 4) \times 360^\circ / 5 \times 4 = 18^\circ$.

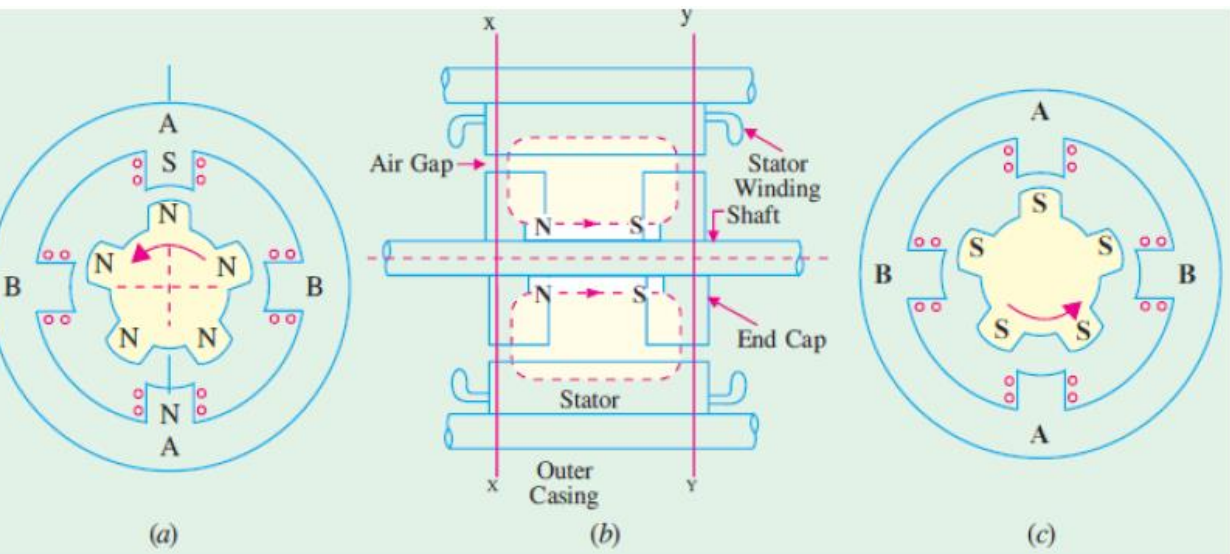

Figure 2.8 Hybrid stepper motor construction and operation

2.3.3.1 Working:

In Figure 2.8 (a), phase A is shown excited such that the top stator pole is a S-pole so that it attracts the top N-pole of the rotor and brings it in line with the A-A' axis. To turn the rotor, phase A is de-energized and phase B is excited positively. The rotor will turn in the CCW direction by a full step of 18° .

Next, phase A and B are energized negatively one after the other to produce further rotations of 18° each in the same direction. The truth table is shown in Figure 2.8 (a). For producing clockwise rotation, the phase sequence should be A+; B-; A-; B+; A+ etc. Practical hybrid stepping motors are built with more rotor poles than shown in Fig. 2.8 in order to give higher angular resolution. Hence, the stator poles are often slotted or castellated to increase the number of stator teeth. As shown in Figure 2.8 (b), each of the eight stator poles has been allotted or castellated into five smaller poles making $N_s = 8 \times 5 = 40^\circ$. If rotor has 50 teeth:

Then step angle = $(50 - 40) \times 360^\circ / 50 \times 40 = 1.8^\circ$. Step angle can also be decreased (and hence resolution increased) by having more than two stacks on the rotor. This motor achieves small step sizes easily and with a simpler magnet structure whereas a purely PM motor requires a multiple permanent-magnet. As compared to VR motor, hybrid motor requires less excitation to achieve a given torque. However, like a PM motor, this motor also develops good detent torque provided by the permanent magnet flux. This torque holds the rotor stationary while the power is switched off. This fact is quite helpful because the motor can be left overnight without fear of its being accidentally moved to a new position.

CHAPTER THREE

SUN TRACKING SYSTEM

3.1 Introduction:

A solar tracking system sets either a solar panel (photovoltaic) or a concentrating solar reflector towards the Sun while tracking the position of the sun. It gained importance mainly because the source of solar energy is free to provide us electricity and heat. Furthermore, it can improve the energy efficiency of any solar power systems and saves a lot of money in the long run despite the additional setup cost and more complex system.

Several factors affecting a solar tracking system are the natural climatic condition of the place where the system is to be used, the load of the system, the placement of the system, the availability of the solar tracking of the chosen system. Many research works laid the design's foundation based on the factors mentioned before with different total accuracy achievement but with similar drawbacks such as increased cost and complex systems.

In this case of location near to the equator, a solar system has a high opportunity to effectively gain electrical power during the hot climates such as at 9.00 a.m. until 3.00 p.m. where the Sun at the optimal positions. As comparison, a solar power system with 15 solar tracking capabilities can maximize the power output while continuously tracking the movement of the Sun.

Generally, solar tracking systems are still expensive and inaccessible for the common consumers or domestic applications, therefore the cost and complexity of the system must be reduced without compromising the total efficiency. On top of that, a good solar tracking system must be able to produce high power output while setting the solar panel based on the changes of the Sun position and consuming a small fraction of the power output. [3, 4]

3.2 Solar Power Fundamentals:

A fundamental understanding of how a photovoltaic panel works is essential producing a highly efficient solar system. Solar panels are formed out of solar cells that are connected in parallel or series. When connected in series, there is an increase in the overall voltage, connected in parallel increases the overall current. Each individual solar cell is typically made out of crystalline silicon, although other types such as ribbon and thin-film silicone are gaining popularity.

PV cells consist of layered silicon that is doped with different elements to form a p-n junction. The p-type side will contain extra holes or positive charges. The n-type side will contain extra electrons or negative charges. This difference of charge forms a region that is charge neutral and acts as a sort of barrier. When the p-n junction is exposed to light, photons with the correct frequency will form an extra electron/hole pair. However, since the p-n junction creates a potential difference, the electrons can't jump to the other side only the holes can. Thus, the electrons must exit through the metal connector and flow through the load, to the connector on the other side of the junction. Because the PV cells generate a current, cells/panels can be modeled as DC current sources the amount of current a PV panel produces has a direct correlation with the intensity of light the panel is absorbing. [6]

The normal to the cell is perpendicular to the cell's exposed face. The sunlight comes in and strikes the panel at an angle. The angle of the sunlight to the normal is the angle of incidence (θ). Assuming the sunlight is staying at a constant intensity (k) the available sunlight to the solar cell for power generation (W) can be calculated as:

$$W=A k \cos(\theta) \tag{3.1}$$

Here, A represents some limiting conversion factor in the design of the panel because they cannot convert 100% of the sunlight absorbed into electrical energy.

By this calculation, the maximum power generated will be when the sunlight is hitting the PV cell along its normal and no power will be generated when the sunlight is perpendicular to the normal. With a fixed solar panel, there is significant power lost during the day because the panel is not kept perpendicular to the sun's rays. A tracking system can keep the angle of incidence within a certain margin and would be able to maximize the power generated. [6]

3.3 An Overview about Tracking Techniques:

Generally there are two types of tracking techniques which are fixed programmable control technique and dynamic tracking technique. One main difference between both techniques is the way of tracking the movement of the Sun. For fixed programmable control technique, the positions of the Sun at different times were predetermined by the programmer based on a real time clock system. The system operated with designated programming algorithms without any feedback signals. In contrast, dynamic tracking technique tracked the locations of the Sun's during the day where the decisions were influenced by feedback signals from sensors or GPS modules. In terms of components list, both systems used various types of motor such as DC motor, stepper motor or servo motor with either digital or analog control circuit.

3.3.1 Types of Tracker Actuator Driver:

Two main types of actuator drivers commonly used in solar tracking system for detecting or locating the sun are the electronic (active) tracker and mechanical (passive) tracker:

3.3.1.1 Electronic (Active) Tracker:

Electronic tracker or commonly name as active utilized electronic sensor or transducer that able to detect the intensity of light such as Light Dependent Resistor (LDR) or photo diode linked to one or more motors for pivoting the position of the solar panel to minimize the angle between the line of the sun and a face

perpendicular to the panel .Those sensors be placed on the trackers at certain spots that prevented any disturbances.

Some of the active trackers were designed with an electro-mechanical system drives and other type of actuators. There are commonly used because of higher efficiency and reliability as compared with trackers without an electro-mechanical system. Figure (3.1) shows an example of an active tracker where the sensor detects the sunlight intensity for finding the difference angle between the lines of the sun with the solar panel. When the angle is reduced to zero, the sunlight strikes the panel at 90° . The motor integrates with the sensor which it operates until the difference angle becomes zero and the panel produced the power for the motor.

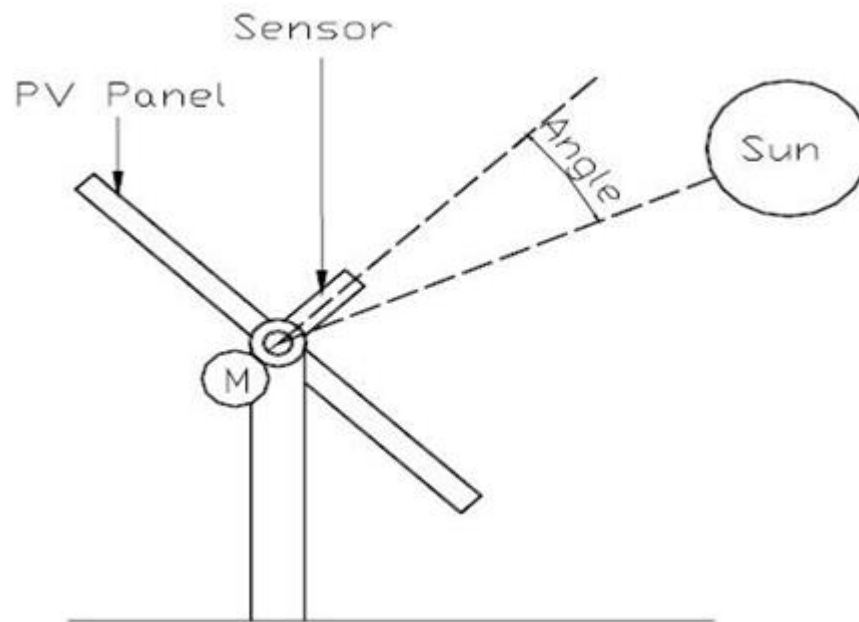

Figure 3.1: An Active Solar tracker

3.3.1.2 Mechanical (Passive) Tracker:

A mechanical or passive tracker manipulated the Sun's radiation to heat up the gases to produce forces to move the tracker. It used two identical containers (each at either side of the panel and equal distance from the central of the solar panel) which are filled with a liquid under partial pressure. Then the tracker is placed with side of the tracker faced on the sun while the sun heats the fluid causing the liquid

to vaporize thus increased the pressure inside the container. Hence the tracker balances the solar panel at a certain slope. This system is simple and cheap and almost maintenance free but it gives less efficiency and need an extra supervision because the tracker rarely locating perpendicularly and difficult to cope with the changes of the movement of the Sun.

Besides, the trackers faced significant problems during the cloudy days where the Sun apparently appeared behind the clouds where the tracker will lose sight of the Sun. As a result, the temperature will fluctuate while the gas inside the container will expand and compress in an inappropriate way. However, passive trackers can also be a relatively low cost way of increasing the output power of a solar array in areas with less clouds like at the desert.

Based on Figure 3.2, the tracker should be placed by facing the PV panel starting from the west since the sunrise is from east where the sun radiation will heat the un-shaded west-side of the container. It will force the liquid into the shaded east-side of the container hence it changes the balance of the tracker and it will swing to the east. The aluminum shadow plates are controlled by heating the liquid and the vapor pressure will increase when one container is exposed to the Sun more than the other which causes it to tilt. The duration of the movement from west to east normally takes about one hour to complete.

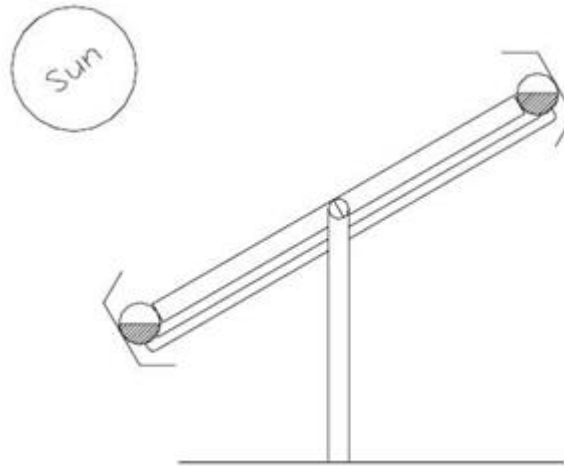

Figure 3.2: A Passive Solar Tracker

3.2.1.3 Altitude / Azimuth Trackers:

This type of tracker used astronomical data or sun position set of rules to determine the location of the Sun for any given time and location. From the set of data collected, the micro controller used those data to control the position of the tracker and follow the position of the sun. The position of the sun will be calculated thus the modules will move by using servo motors. Then, the tracker frame will be built by referring the position measured by encoders.

3.2.2 Type of Solar Tracker Axis:

Generally, there are two main types of solar tracker axis which are single axis and double axis trackers.

3.2.2.1 Single Axis Tracker:

There are two types of single axis tracker which can be either in vertical axis or horizontal axis. Any countries in the tropical region should deploy horizontal type of tracker since the Sun normally positioned at the highest point. Meanwhile, the vertical type will be used by other country if the sun position is low most of the time and have high altitudes, or the duration of summer day is longer. It has a manually adjustable tilt angle of 0 to 45° and able to the Sun automatically from East to West or North to South. For this system, PV panels are used as light sensor

in order to avoid unimportant tracking movement. The tracker will position look up the horizontal during night time. Figure 3.3 and Figure 3.4 shows example of single axis trackers.

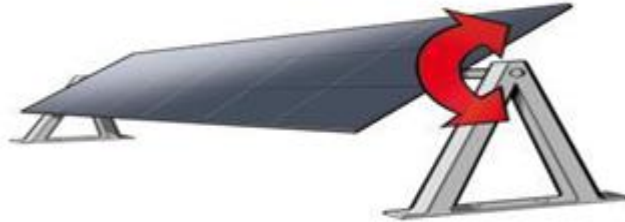

Figure 3.3: A Horizontal Single Axis Solar Tracker



Figure 3.4: A Vertical Single Axis Solar Tracker

3.2.2.2 Dual Axis Tracker:

A dual axis or double axis tracker is a tracker that has two degrees of freedom that act as axes of rotation which are horizontal and vertical axis where the vertical axis pivot shaft allows the tracker to move to a compass point such as east to west while the horizontal axis works as elevation that moves depending on the altitude of the sun. Hence this system is able to tracks the Sun's movement in any positions either east to west or north to south. This system should be operated under a computer control or a micro controller according to the expected solar position and need to be calibrated with tracking sensor to control motors that orient the panels toward the sun. Therefore, this system allows the increase of power output energy which

is approximately around 40% gain rather than the fixed panels. Figure 3.5 shows an example of dual axis solar tracking.



Figure 3.5 Dual axis

3.2.3 Type of Tracker Mount :

Based on the overview of solar tracking, these systems can be categorized into two types of tracker which are active or passive, then choose to its modes either single axis mode or dual axis mode tracker. Single axis tracker can be divided into two types of mount which are polar and altitude-azimuth.

Normally trackers that have one axis aligned close to the earth rotational axis or one axis aligned perpendicular to the imaginary disc containing the apparent path of the Sun or “ecliptic” are known as polar tracker. It also known as single axis trackers since if only has single drive mechanism for their operating system. Figure 2.5 shows a sample of polar axis tracking ridge concentrator. This type of mount is physically adjusted to compensate for the shift of ecliptic through the seasons and normally there will be changes of seasons at least twice a year; during spring and summer while the other is during autumn and winter. Moreover, this method is low cost and can be applied for passive trackers.

On the other hand, dual axis trackers also have two type of mount which are Tip-tilt dual axis tracker and Azimuth-altitude dual axis tracker. For Tip-tilt tracker, the PV panel is mounted on the top of the pole with the T or H-shaped rotation bearing mechanism where it gives vertical rotation of the panels and main mounting points for the array. [6].



Figure 3.6: The Polar Axis Tracking Ridge Concentrator

3.4 Existing Tracking Technology:

PV panel is dependent on its angular position to the sun. A PV panel must be perpendicular to the sun for maximum solar absorption, which is done by using a tracking system. Multiple tracking systems exist, which vary in reliability, accuracy, cost, and other factors. A tracking system must be chosen wisely to ensure that the tracking method increases the power gained instead of decreasing it. [6]

CHAPTER FOUR

SIMULATION AND RESULTS

4.1 System layout and Control:

The solar tracker system requires movement in two directions, and uses electric motor as prime mover, based on this; solar tracker system motion control is simplified to an electric motor motion control.

In solar tracking system design, any light sensitive device can be used as input sensor unit to detect and track the sun position, based on sensors readings, and generated sun tracking error, the control unit generates the voltage used to command the circuit to drive the motor, that outputs the rotational displacement of electric motor, which is the motion of solar tracking system.

Simplified block diagram representation of solar tracking system is shown in Figure 4.1.

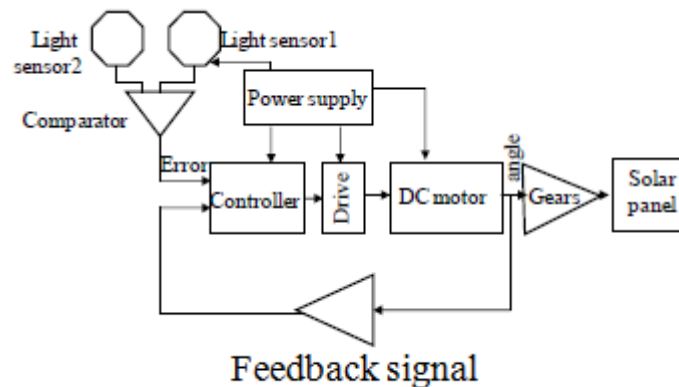

Figure 4.1 Simplified block diagram of solar tracking system

4.1.1 Light sensor selection and circuit:

Light detecting sensor that may use to build solar tracker include; phototransistors, photodiodes, LDR and LLS05-A light sensors, a suitable, inexpensive, simple and easy to interface sensor is analog LDR. Depending on particular application and required maximum energy receiving of solar panel, one-axis (one directional) sun tracking system using two light detectors sensors are mounted on the solar panel and placed in an enclosure, the LDRs are screened from each other by opaque surfaces. For one-axis sun tracking system, one light tracking circuit consisting of two sensors, and one electric motor are used.

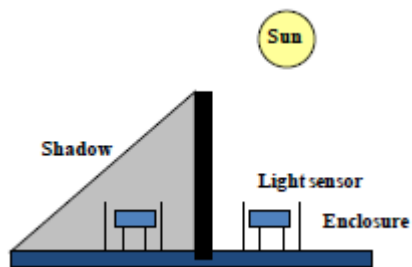

Figure 4.2 LDR position

4.1.2 Actuator and drive selection:

Electric motors most used for solar tracker are PMDC and stepper motors, the proper selection of motor and drive combination can save energy and improve performance. A suitable, available, easy to control and interface selection is stepper motor. For bidirectional driving, a motor can be driven via ULN2003.

The ULN2003 is a monolithic high voltage and high current Darlington transistor arrays. It consists of seven NPN darlington pairs that features high-voltage outputs with common-cathode clamp diode for switching inductive loads. The collector-current rating of a single darlington pair is 500mA. The darlington pairs may be paralleled for higher current capability. Applications include relay drivers, hammer drivers, lamp drivers, display drivers (LED gas discharge), line drivers,

and logic buffers. The ULN2003 has a 2.7kΩ series base resistor for each darlington pair for operation directly with TTL or 5V CMOS devices.

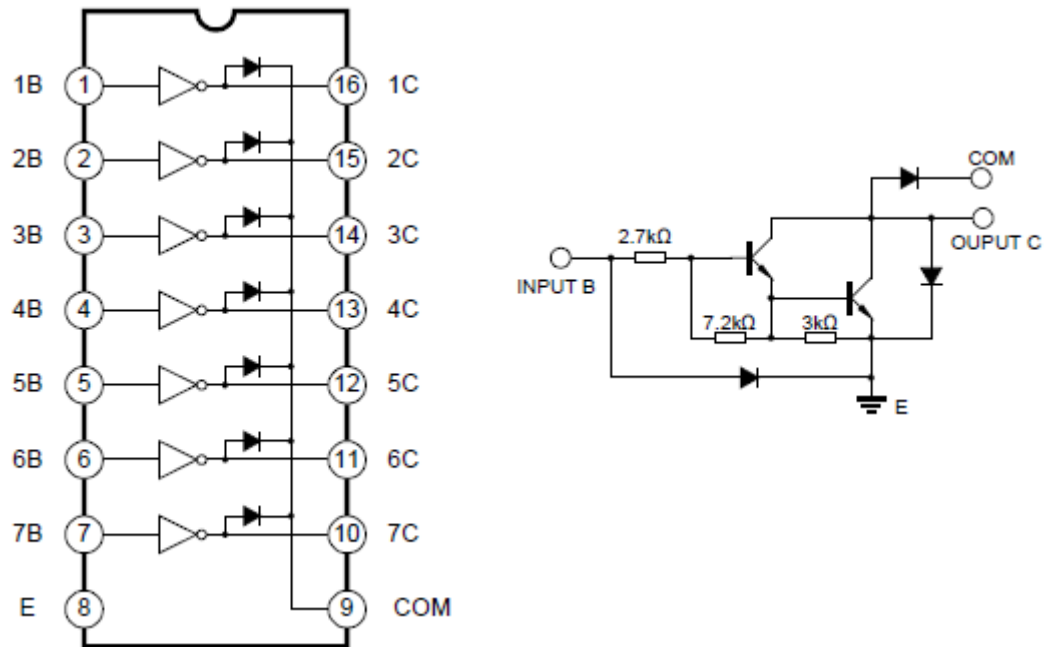

Figure 4.3 driver internal construction

4.1.3 Stepper motor:

The 28BYJ-48 is a small, cheap, 5 volt geared stepping motors. These stepping motors are apparently widely used to control things like automated blinds, A/C units and are mass produced. Due to the gear reduction ratio of approximately 64:1 it offers decent torque for its size at speeds of about 15 rotations per minute (RPM). With some software “trickery” to accelerate gradually and a higher voltage power source (tested with 12 volts DC) it’s able to get about 25+ RPM. The low cost and small size makes the 28BYJ-48 an ideal option for small robotic applications, and an excellent introduction to stepper motor control with Arduino.



Figure 4.4 PM stepper motor model 28BYJ-48 – 5V

Table 4.1 PM stepper motor properties

Weight	30g
Motor Type	Unipolar stepper motor
Rated voltage	5VDC
Number of Phase	4
Speed Variation Ratio	1/64
Stride Angle	5.625° /64
Frequency	100Hz
DC resistance	50Ω±7%(25°C)
Idle In-traction Frequency	> 600Hz
Idle Out-traction Frequency	> 1000Hz
In-traction Torque	>34.3mN.m(120Hz)
Self-positioning Torque	>34.3mN.m
Friction torque	600-1200 gf.cm
Pull in torque	300 gf.cm
Insulated resistance	>10MΩ(500V)
Insulated electricity power	600VAC/1mA/1s
Insulation grade	A
Rise in Temperature	<40K(120Hz)
Noise	<35dB(120Hz,No load,10cm)
Model	28BYJ-48 – 5V

4.1.4 Control system and microcontroller:

Control engineering is based on the foundations of feedback theory and linear system analysis, and it generates the concepts of network theory and communication theory. Accordingly, control engineering is not limited to any engineering discipline but is applicable to aeronautical, chemical, mechanical, environmental, civil, and electrical engineering.

Control system is an interconnection of components forming a system configuration that will provide a desired system response. The basis for analysis of a system is the foundation provided by linear system, which assumes a cause effect relationship for the components of a system. A component or process to be controlled can be represented by a block as shown in Figure 4.5.

An open-loop control system utilizes a controller or control actuator to obtain the desired response as shown in Figure (4.5) the open-loop control system utilizes an actuating device to control the process directly without using device. An example of an open-loop control system is an electric toaster

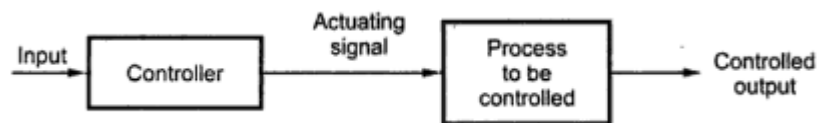

Figure 4.5: Open-loop control system

A closed-loop control system (Figure 4.6) utilizes an additional measure of the actual output to compare the actual output with the desired output response. The measure of the output is called the feedback signal.

A feedback control system is a control system that tends to maintain a relationship of one system variable to another by comparing functions of these variables and using the difference as a means of control. As the system is becoming more complex, the inter relationship of many controlled variables may be considered in the control scheme. An example of closed-loop control system is a person steering

automobile by looking at the auto's location on the road and making the appropriate adjustments.

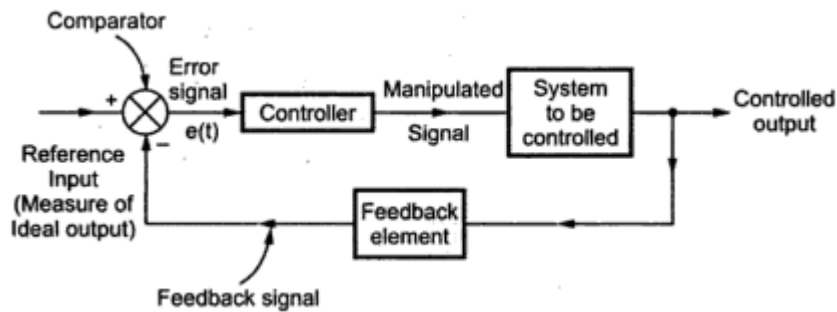

Figure 4.6: Closed loop control system

The main purpose of the controller is to receive data from the sensors, process it, and give signals to drive the motors and actuators. Looking at it simply, a human can take the place of a controller. A person can see where the sun is and rotate the tracker manually to get the most energy. But it is not a feasible option for a long term or when there is more than one tracker, like in a solar power plant. So automated controllers become a necessity. Controllers must also take into account what to do when the sun sets, when the wind is too high, or other physical conditions.

The received signals from sensors converted to digital signals in rang of binary numbers from 0 to 1023 and processed by operations depend on code witch written by programmer to get specific according to system needs. All these functions can be done by one control system called ARDUINO UNO microcontroller and here are some definition about ARDUINO UNO:



Figure 4.7 Arduino Uno

The Arduino Uno is a microcontroller board based on the ATmega328. It has 14 digital input/output pins (of which 6 can be used as PWM outputs), 6 analog inputs, a 16 MHz ceramic resonator, a USB connection, a power jack, an ICSP header, and a reset button. It contains everything needed to support the microcontroller; simply connect it to a computer with a USB cable or power it with an AC-to-DC adapter or battery to get started.

Table 4.2 Arduino UNO properties

Microcontroller	ATmega328
Operating Voltage	5V
Input Voltage	7-12V(recommended)
Input Voltage (limits)	6-20 V
Digital I/O Pins	14 (of which 6 provide PWM output)
Analog Input Pins	6
DC Current per I/O Pin	40 mA
DC Current for 3.3V Pin	50 mA
Flash Memory	32 KB (ATmega328) of which 0.5 KB used by boot loader
SRAM	2 KB (ATmega328)
EEPROM	1 KB (ATmega328)
Clock Speed	16 MHz

4.1.5 Power supply:

According to simple prototype project and small motor selection; all system components supplied from 5V DC source which can be obtained from AC/DC adapter or computer USB ports.

4.2 Full simulation diagram:

The simulations are done for solar tracker system using the proteus software. The complete simulation diagram is show in figure (4.8)

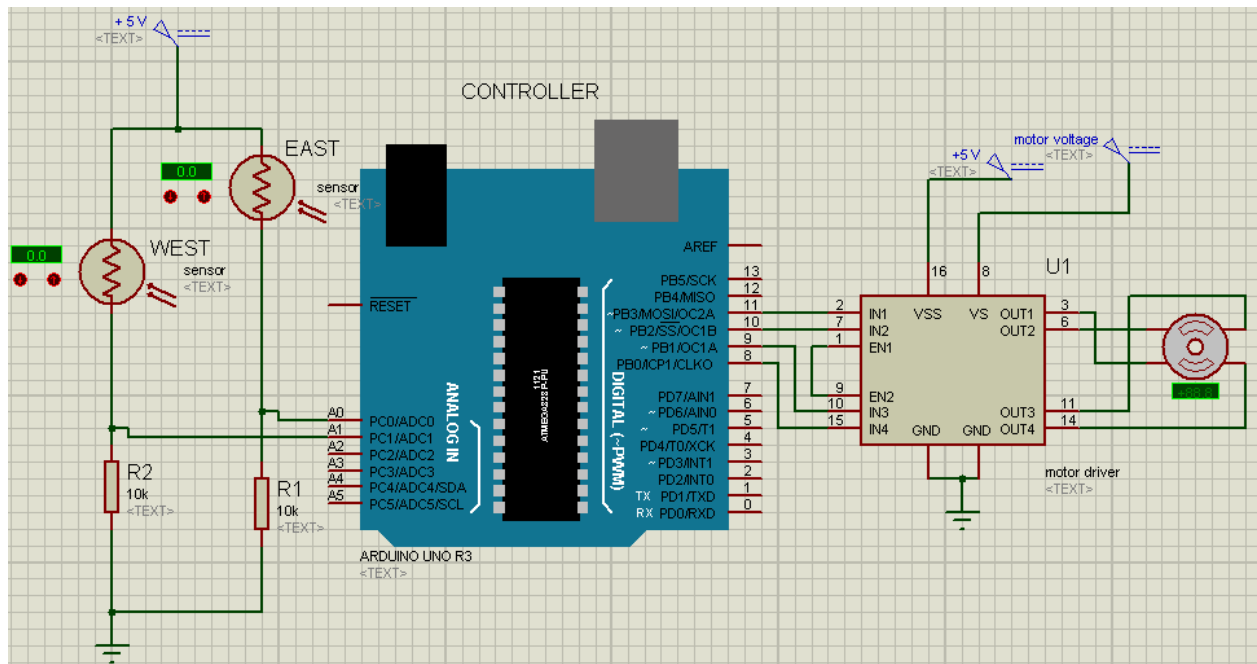

Figure 4.8 Full simulation diagram

In figure 4.8 witch shows Full simulation diagram of single axis solar tracker system ; is consists of one permanent magnet stepper motor , ULN2003 driver two LDR sensors ,resistors and Arduino UNO controller.

The solar panel is moved by stepper motor one step every reading either west or east (CW or CCW) and the motor will stop if the readings of the two sensors are equal.

The code of software programming had written by Arduino CC language as shows in Appindix.

4.3 Results and Description:

Sun tracking system shows in figure 4.8 designed to track the sun light depending on the reading of the two LDR sensor inserted with the solar panel. So it moves the solar panel towards the direction of the higher reading and stops when both readings are equal. And continue doing this until sunset (reach 180 degree) and hold on this position until the sun light disappears after that it resets to its initial position.

Figure 4.9 shows that the motor moving solar panel to track the sun light while the sun moving from east to west. That is mean the west reading is getting higher than the east because the east sensor became on the shade position.

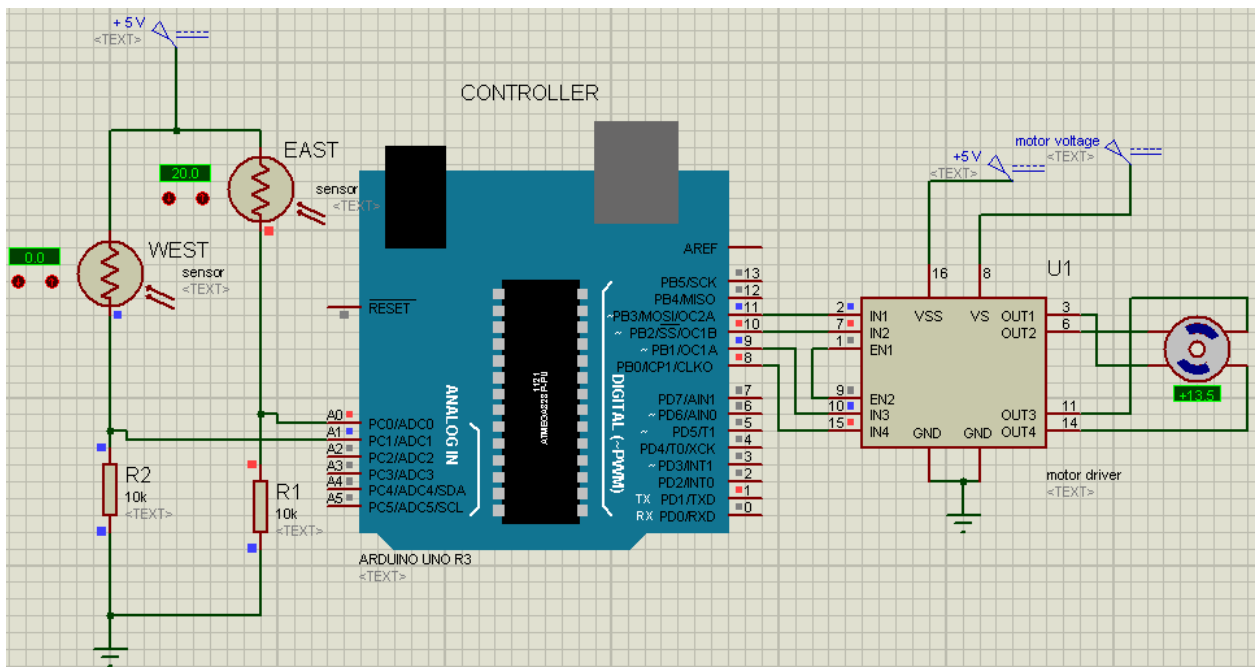

Figure 4.9 sun tracker system while tracking

Figure 4.10 shows that the motor will stop moving when both LDR sensors readings are equal.

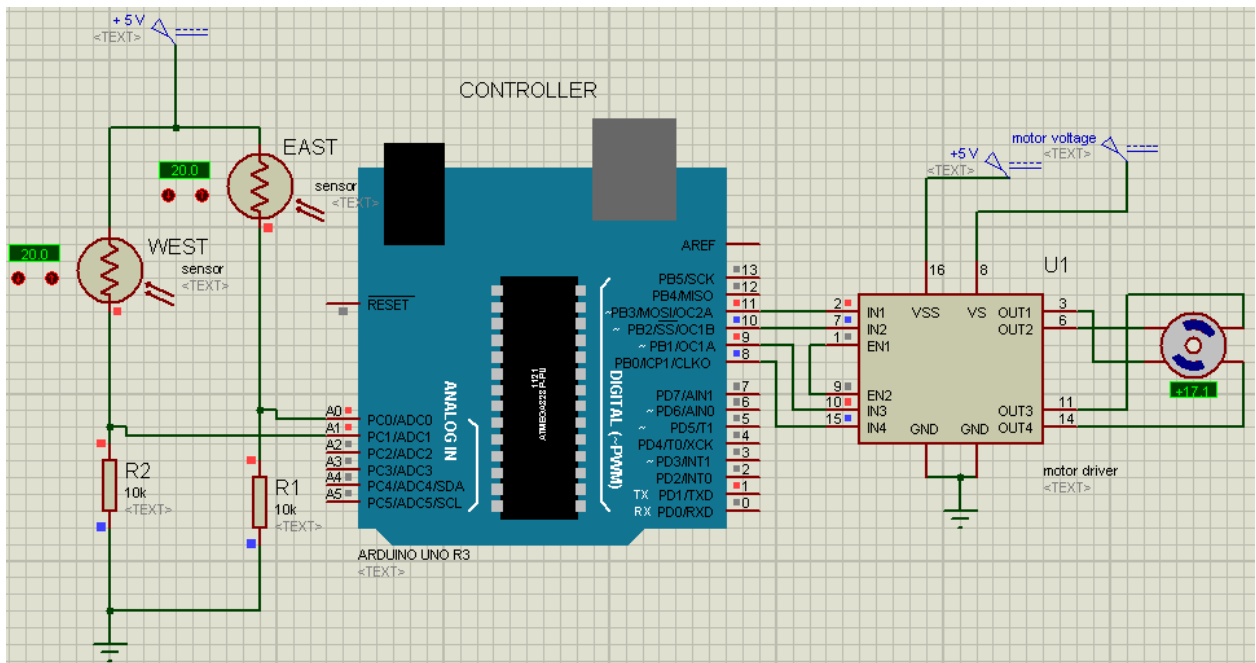

Figure 4.10 sun tracker while holding position

Figure 4.11 shows that the solar tracker will correct its position if it got passed the desired position. The motor will rotate backwards slowly when reading of the east sensor is higher than the west sensor reading.

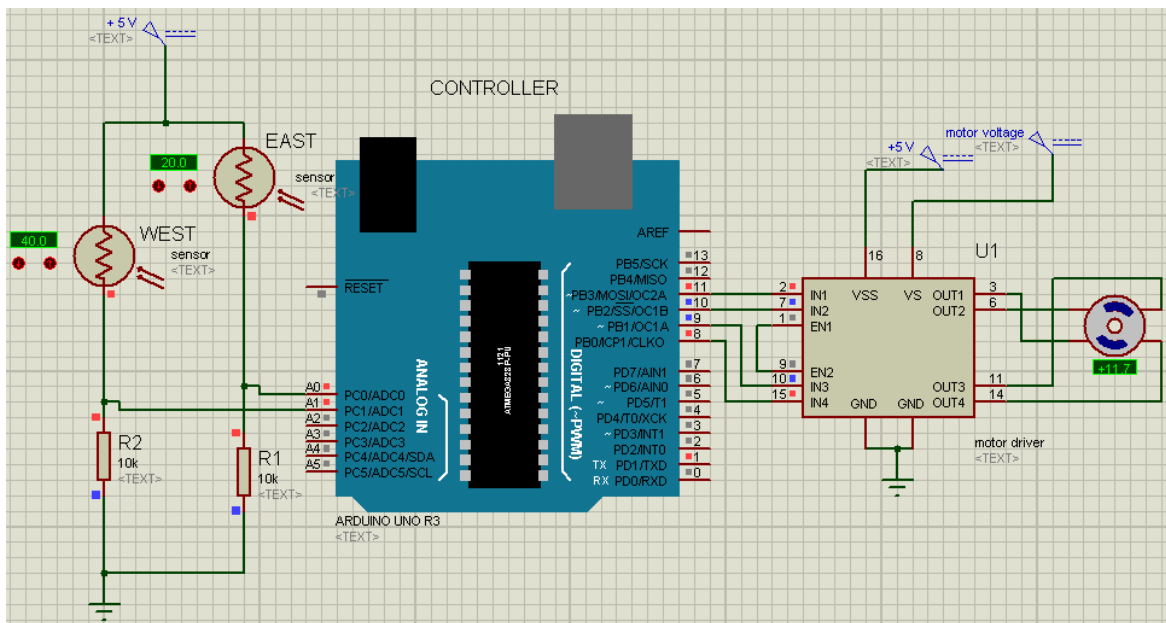

Figure 4.11 solar tracker while correcting

Figure 4.12 shows the position of sun tracker during sunset it holds this position until the sun light disappear then the motor will rotate backwards quickly towards its initial position.

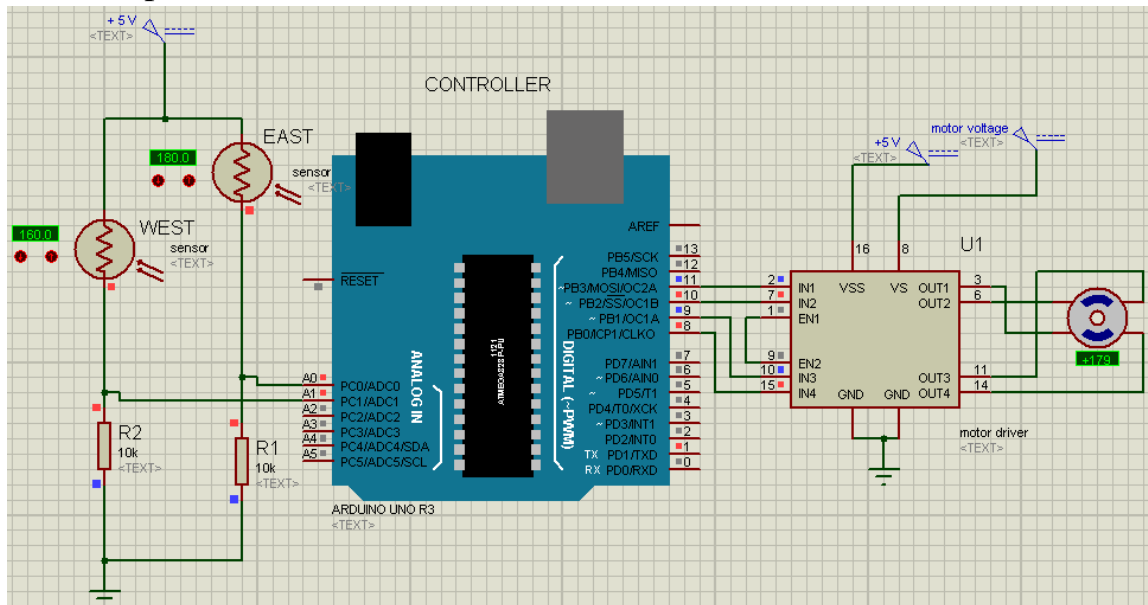

Figure 4.12 the solar tracker during sunset

4.4 Hardware circuit diagram:

According to simulation circuit diagram which shows in figure 4.8; all the components are connected as shows on figure below:

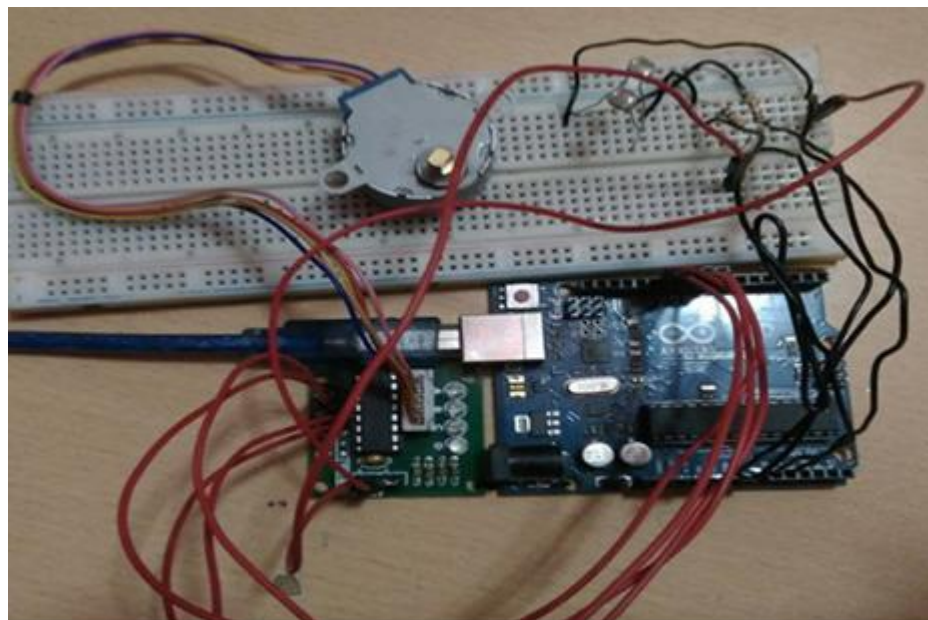

Figure 4.13 hardware circuit diagram

CHAPTER FIVE

CONCLUSION AND RECOMMENDATIONS

5.1 Conclusion:

A stepper motor, a unique type of DC motor, rotates in fixed steps of a certain number of degrees: 30°, 15°, 1.8°, and so on. The rotor (the part that moves) is made of permanent magnets or iron and contains no coils and therefore has no brushes. Surrounding the rotor is the stator, which contains a series of field pole electromagnets. As the electromagnets are energized one after the other, the rotor is pulled around in a circle.

Stepper motors used in position systems are usually operated open-loop that is without feedback sensors. The controller will step the motor many times and expects the motor to be there.

The complete simulation diagram of the solar tracker system is built using proteus software. A series of simulation studies have been conducted in order to evaluate the performance of the solar tracker system. The simulation results show good performance of the solar tracker system controlled by microcontroller.

5.2 Recommendations:

We recommend the following topics to be implemented to our project:

- To use PID controller for tracking the sun location for maximum power.
- To use fuzzy logic for tracking the sun location.
- To use fixed control algorithms and compare the result of dynamic system.
- To design dual axis tracker

References:

- [1] Kilian, "Modern Control Technology - Components and Systems", Cengage (2000).
- [2] Matthew Scarpino "Motors for Makers_ A Guide to Steppers, Servos, and Other Electrical Machines" Que Publishing (2015)
- [3] Tiberiu Tudorache¹, Liviu Kreindler¹, "Design of a Solar Tracker System for PV Power Plants", University Politehnica of Bucharest, Romania, June-2013.
- [4] İ. Sefa, M. Demirtas, and İ. Çolak, "Application of one-axis sun tracking system," *Energy Conversion and Management*, vol. 50, pp. 2709-2718, 2009.
- [5] B.L Theraja and A.K Theraja "Electrical Technology"
- [6] Adrian Catarius , "Azimuth-Altitude dual axis solar tracker", December 2010

APPENDIX

Arduino CC code for one axis solar tracker:

```
const int vr = .008;
float east = 0;
float west = 0;
float def = 0;
int count = 0;
#include <Stepper.h>
#define stepsPerRevolution 200
// initialize the stepper library on pins 8 through 11:
Stepper myStepper(stepsPerRevolution, 8, 9, 10, 11);
void setup()
{
  // set the speed at 60 rpm:
  myStepper.setSpeed(60);
  // initialize the serial port:
  Serial.begin(9600);
}
void loop()
{
  east = analogRead(A0)*5/1023;
  west = analogRead(A1)*5/1023;
  def = east - west;
  if(def > vr && count < 100)
  {
    // steps one step in CW direction:
    myStepper.step(1);
```



```
count++;
delay(500);}
if(west>east&&(west-east)>vr&& count > 0)
{
    // steps one step in CCW direction:
myStepper.step(-1);
count--;
delay(500);}
if (east < .06 && west < .06 && count > 0)
{
    // steps one step in CCW direction for reset.
myStepper.step(-1);
}
}
```