

Sudan University of Science and Technology

College of Engineering

Biomedical Engineering

Thesis Title

Hybrid Model of Respiratory System

**A project submitted in partial fulfilment of the requirements for
the degree of**

B.Sc. (Honor) in Biomedical Engineering

Prepared By:

Reem Ahmed Suliman Degais.

Ruaa Gamal Abu-zaid Saeed.

Tsabeh AbdAljalil Adm Abdaljalil.

Supervisor:

Dr. Fargoon mohamed Ahmed

October 2016

الآية

قال تعالى :

) وقل ربي زدني

علما (

صدق الله العظيم

Dedication:

To our parents...

To our Islamic nation...

To our friends, teachers...

And everyone how supported us to move forward...

Acknowledgements

I would like to express my special thanks to my supervisor Dr. Fargoon for his endless support ,advice and his continuous direction and giving us this golden opportunity to do this project . My thanks also extended to all members of our staff who spare no effort to help when we need help.

And also my thanks to the staff of Someta company for medical devices for providing us most of the component .

In addition, we would like to express my gratitude to our parent. Without their support and encouragement. We would not have finished this work.

Abstract

The simulator is designed for educational purposes and for calibration and development of the ventilator to get accurate reading and results help in the diagnosis and treatment. The aim of this project is building a hybrid model of the human respiratory system which can be linked to medical devices. We designed and implemented simulator by arduino, normal respiratory system signal (pressure, volume and flow) generated by MATLAB.

المستخلص

تم تصميم المحاكى للاغراض التعليميه ولتطوير ومعايرة اجهزه التنفس الصناعي للحصول علي نتائج صحيحة تساعد في التشخيص والعلاج . الهدف من هذا المشروع هو بناء نموذج هجين للجهاز التنفسي البشري الذي يمكن ربط الاجهزه الطبيه مع الرئتين الافتراضيه . وهو جهاز لمحاكاة الجهاز التنفسي البشري .قمنا بتصميم وتنفيذ محاكاة بواسطه اوردوينو , اشاره الجهاز التنفسي الطبيعيه (الضغط والحجم والتدفق).

Table of Contents

Dedication	iii
Acknowledgements	iv
Abstract	v
List of Figures	ix
List of Tables	x
CHAPTER 1 INTRODUCTION	1
1.1 Problem statement	2
1.1.1 Objectives:.....	2
1.1.2 project Outline :.....	2
CHAPTER 2 THEORETICAL BACKGROUND	3
2.1 Anatomy of respiratory system:	3
2.1.1 Nose and Nasal Cavity:	3
2.1.2 Mouth:	3
2.1.3 Pharynx:.....	4
2.1.4 Larynx:	4
2.1.5 Trachea:	5
2.1.6 Bronchi and Bronchioles:	5
2.1.7 Lungs:.....	6
2.1.8 Muscles of Respiration:	7
2.2 Physiology of respiratory system:	8
2.3 Modelling of respiratory system:.....	10
CHAPTER 3 LITERATURE REVIEW	11
3.1 Literature Review of respiratory system:	11

CHAPTER 4 METHODOLOGY	20
4.1 Software:	20
4.2 Hardware.....	24
4.2.1 Arduino:.....	26
4.2.2 (mpx2200D) pressure sensors:	28
4.2.3 LCD (LMB162AFC):.....	28
4.2.4 TRANSISTOR H32 TIP 121:	29
4.2.5 VALVE ZC-3H:	29
4.2.6 Component and specifications:.....	30
CHAPTER 5 RESULT AND DISCUSSIONS	31
5.1 Results:.....	31
5.2 Discussion:.....	33
CHAPTER 6 CONCLUSION AND RECOMMENDATION.....	34
6.1 Conclusion:	34
6.2 Recommendation:	34
Reference.....	35

List of Figures

Figure 2-1: Anatomy of respiratory system.....	8
Figure 2-2: Standard lung volumes and capacities typical values for a 70-Kg adult are shown	9
Figure 4-1 Lung Hydraulic model	21
Figure 4-2 Lung Electrical model	21
Figure 4-3 Block diagram of hardware.....	25
Figure 4-4 Proteus block diagram.....	25
Figure 4-5 Arduino codes	26
Figure 5-1 Simulation result from SIMULINK.....	31
Figure 5-2 hard ware.....	32
Figure 5-3 project circuit	33

List of Tables

Table 4-1 Physiological parameter22

Chapter 1 Introduction

Physiological systems are very complex and hierarchical in structure and the complexity is present in every level including the organs, the cell and biochemical molecules. The great complexity of physiological system makes it difficult to describe, interpret for or explain their behavior without the assistance of some form of model. Simulation and modeling in respiratory medicine offer a number of opportunities. First, model and simulation can give us better understanding of the path physiology of disease processes. For example, constructing a multi –unit lung model with different regional ventilation and perfusion properties can help us understand gas exchange disturbance. Second simulation and molding are powerful educational tools. Observing a professional in diagnosis and treatment decisions indeed, a wrong decision on an education simulator lead only to clinician learning. Not to a real patient disaster education simulator can also be used for clinical testing and licensing. Third, a simulator or model can help predict a patient response to planned therapies. For example, a mechanical lung model may be used to predict how to patient respiratory system will respond to a change in a ventilator setting. Fourth, a computerized anatomic bronchoscopy and other invasive techniques. Fifth, simulator anatomic lesions and guide improve existing and new ventilation devices, technique and model.

1.1 Problem statement

All instrumentation needs calibration method criterion method to ensure accurate reading and result, and special tools must be available. Unfortunately in Sudan these tools are not available and this affects the diagnosis and therapy.

1.1.1 Objectives:

General objectives:

-Study hybrid model of respiratory system.

Specific objectives:

1. To design model helping for teaching.
2. To calibrate clinical device (ventilator).
3. To improve our understanding of the respiratory system.

1.1.2 Project Outline:

In this research, chapter two contains a theoretical background ,while literature review is contains in chapter three ,the methodology is explains in chapter four, next in chapter five results and discussion are explain, and finally chapter six includes conclusion and recommendation.

Chapter 2 Theoretical background

2.1 Anatomy of respiratory system:

2.1.1 Nose and Nasal Cavity:

The nose and nasal cavity form the main external opening for the respiratory system and are the first section of the body's airway—the respiratory tract through which air moves. The nose is a structure of the face made of cartilage, bone, muscle, and skin that supports and protects the anterior portion of the nasal cavity. The nasal cavity is a hollow space within the nose and skull that is lined with hairs and mucus membrane. The function of the nasal cavity is to warm, moisturize, and filter air entering the body before it reaches the lungs. Hairs and mucus lining the nasal cavity help to trap dust, mold, pollen and other environmental contaminants before they can reach the inner portions of the body.

2.1.2 Mouth:

The mouth, also known as the oral cavity, is the secondary external opening for the respiratory tract. Most normal breathing takes place through the nasal cavity, but the oral cavity can be used to supplement or replace the nasal cavity's functions when needed. Because the pathway of air entering the body from the mouth is shorter than the pathway for air entering from the nose, the mouth does not warm and moisturize the air entering the lungs as well as the nose performs this function. The one advantage of breathing through the mouth is that its shorter distance and larger diameter allows more air to quickly enter the body.

2.1.3 Pharynx:

The pharynx, also known as the throat, is a muscular funnel that extends from the posterior end of the nasal cavity to the superior end of the esophagus and larynx. The pharynx is divided into 3 regions: the nasopharynx, oropharynx, and laryngopharynx. The nasopharynx is the superior region of the pharynx found in the posterior of the nasal cavity. Inhaled air from the nasal cavity passes into the nasopharynx and descends through the oropharynx, located in the posterior of the oral cavity. Air inhaled through the oral cavity enters the pharynx at the oropharynx. The inhaled air then descends into the laryngopharynx, where it is diverted into the opening of the larynx by the epiglottis. The epiglottis is a flap of elastic cartilage that acts as a switch between the trachea and the esophagus. Because the pharynx is also used to swallow food, the epiglottis ensures that air passes into the trachea by covering the opening to the esophagus. During the process of swallowing, the epiglottis moves to cover the trachea to ensure that food enters the esophagus and to prevent choking.

2.1.4 Larynx:

The larynx, also known as the voice box, is a short section of the airway that connects the laryngopharynx and the trachea. The larynx is located in the anterior portion of the neck, just inferior to the hyoid bone and superior to the trachea. Several cartilage structures make up the larynx and give it its structure. The epiglottis is one of the cartilage pieces of the larynx and serves as the cover of the larynx during swallowing. Inferior to the epiglottis is the thyroid cartilage, which is often referred to as the Adam's apple as it is most commonly enlarged and visible in adult males. The thyroid holds open the anterior end of the larynx and protects the vocal folds. Inferior to the thyroid cartilage is the ring-shaped cricoid cartilage which holds the larynx open and supports its

posterior end. In addition to cartilage, the larynx contains special structures known as vocal folds, which allow the body to produce the sounds of speech and singing. The vocal folds are folds of mucous membrane that vibrate to produce vocal sounds. The tension and vibration speed of the vocal folds can be changed to change the pitch that they produce.

2.1.5 Trachea:

The trachea, or windpipe, is a 5-inch long tube made of C-shaped hyaline cartilage rings lined with pseudo stratified ciliated columnar epithelium. The trachea connects the larynx to the bronchi and allows air to pass through the neck and into the thorax. The rings of cartilage making up the trachea allow it to remain open to air at all times. The open end of the cartilage rings faces posteriorly toward the esophagus, allowing the esophagus to expand into the space occupied by the trachea to accommodate masses of food moving through the esophagus. The main function of the trachea is to provide a clear airway for air to enter and exit the lungs. In addition, the epithelium lining the trachea produces mucus that traps dust and other contaminants and prevents it from reaching the lungs. Cilia on the surface of the epithelial cells move the mucus superiorly toward the pharynx where it can be swallowed and digested in the gastrointestinal tract.

2.1.6 Bronchi and Bronchioles:

At the inferior end of the trachea, the airway splits into left and right branches known as the primary bronchi. The left and right bronchi run into each lung before branching off into smaller secondary bronchi. The secondary bronchi carry air into the lobes of the lungs—2 in the left lung and 3 in the right lung. The secondary bronchi in turn split into many smaller tertiary bronchi within each lobe. The tertiary bronchi split into many smaller bronchioles that spread

throughout the lungs. Each bronchiole further splits into many smaller branches less than a millimeter in diameter called terminal bronchioles. Finally, the millions of tiny terminal bronchioles conduct air to the alveoli of the lungs. As the airway splits into the tree-like branches of the bronchi and bronchioles, the structure of the walls of the airway begins to change. The primary bronchi contain many C-shaped cartilage rings that firmly hold the airway open and give the bronchi a cross-sectional shape like a flattened circle or a letter D. As the bronchi branch into secondary and tertiary bronchi, the cartilage becomes more widely spaced and more smooth muscle and elastin protein is found in the walls. The bronchioles differ from the structure of the bronchi in that they do not contain any cartilage at all. The presence of smooth muscles and elastin allow the smaller bronchi and bronchioles to be more flexible and contractile.

The main function of the bronchi and bronchioles is to carry air from the trachea into the lungs. Smooth muscle tissue in their walls helps to regulate airflow into the lungs. The dilated airway provides less resistance to airflow and allows more air to pass into and out of the lungs. The smooth muscle fibers are able to contract during rest to prevent hyperventilation. The bronchi and bronchioles also use the mucus and cilia of their epithelial lining to trap and move dust and other contaminants away from the lungs.

2.1.7 Lungs:

The lungs are a pair of large, they relax. The left and right lungs are slightly different in size and shape due to the heart pointing to the left side of the body. The left lung is therefore slightly smaller than the right lung and is made up of 2 lobes while the right lung has 3 lobes.

The interior of the lungs is made up of spongy tissues containing many capillaries and around 30 million tiny sacs known as alveoli. The alveoli are

cup-shaped structures found at the end of the terminal bronchioles and surrounded by capillaries. The alveoli are lined with thin simple squamous epithelium that allows air entering the alveoli to exchange its gases with the blood passing through the capillaries. Spongy organs found in the thorax lateral to the heart and superior to the diaphragm. Each lung is surrounded by a pleural membrane that provides the lung with space to expand as well as a negative pressure space relative to the body's exterior.

. The negative pressure allows the lungs to passively fill with air as they relax. The left and right lungs are slightly different in size and shape due to the heart pointing to the left side of the body. The left lung is therefore slightly smaller than the right lung and is made up of 2 lobes while the right lung has 3 lobes.

The interior of the lungs is made up of spongy tissues containing many capillaries and around 30 million tiny sacs known as alveoli. The alveoli are cup-shaped structures found at the end of the terminal bronchioles and surrounded by capillaries. The alveoli are lined with thin simple squamous epithelium that allows air entering the alveoli to exchange its gases with the blood passing through the capillaries.

2.1.8 Muscles of Respiration:

Surrounding the lungs are sets of muscles that are able to cause air to be inhaled or exhaled from the lungs. The principal muscle of respiration in the human body is the diaphragm, a thin sheet of skeletal muscle that forms the floor of the thorax. When the diaphragm contracts, it moves inferiorly a few inches into the abdominal cavity, expanding the space within the thoracic cavity and pulling air into the lungs. Relaxation of the diaphragm allows air to flow back out the lungs during exhalation.

Between the ribs are many small intercostal muscles that assist the diaphragm with expanding and compressing the lungs. These muscles are divided into 2 groups: the internal intercostal muscles and the external intercostal muscles. The internal intercostal muscles are the deeper set of muscles and depress the ribs to compress the thoracic cavity and force air to be exhaled from the lungs. The external intercostal are found superficial to the internal intercostal and function to elevate the ribs, expanding the volume of the thoracic cavity and causing air to be inhaled into the lungs.

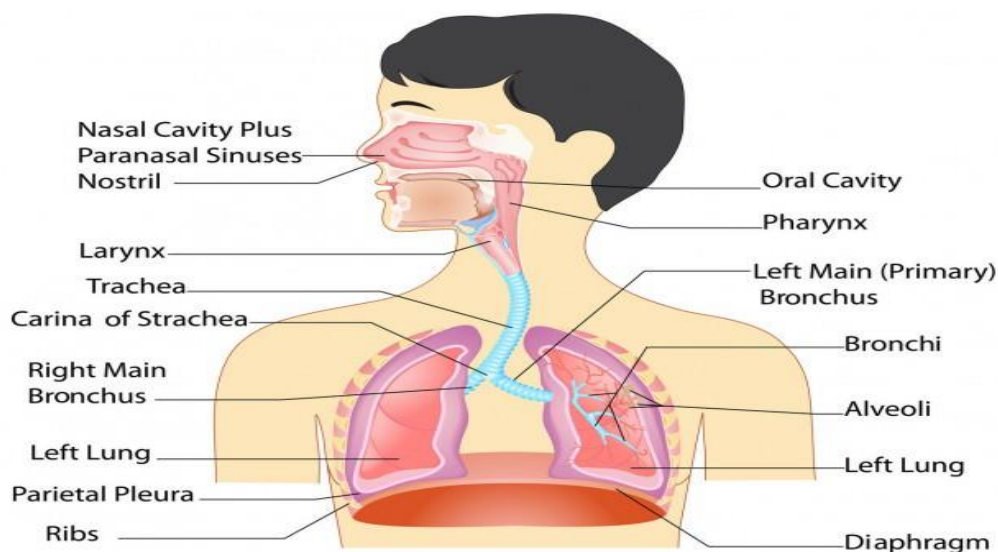

Figure 2-1: Anatomy of respiratory system

2.2 Physiology of respiratory system:

-Tidal volume (TV): Volume of air inspired or expired each breath=0.5l in adult males and females at rest.

-Inspiratory reserve volume (IRV): Volume of air inspired by maximum inspiratory effort following tidal inspiration =3l in adult male and 1.9 in adult female.

-Inspiratory capacity(IC): Volume of air inspired by maximum inspiratory effort following tidal expiration =TV+IRV.

-Expiratory reserve volume (ERV): Volume of air expired by maximum expiratory effort following tidal expiration =1l in adult males and 0.7 in adults female.

-Vital capacity (VC): Volume of air expired by maximum expiration following maximum inspiration (=IRV+TV+ERV OR=IC+ERV).

Normal value: about 5l in adult male, 4l in adult female.

-Force vital capacity (FVC): Volume of air expired forcefully by maximum expiration following maximum inspiration .since expiration normally take about 4s up to 6s. Forced expiratory time that takes longer than 6 second indicates airway obstruction.

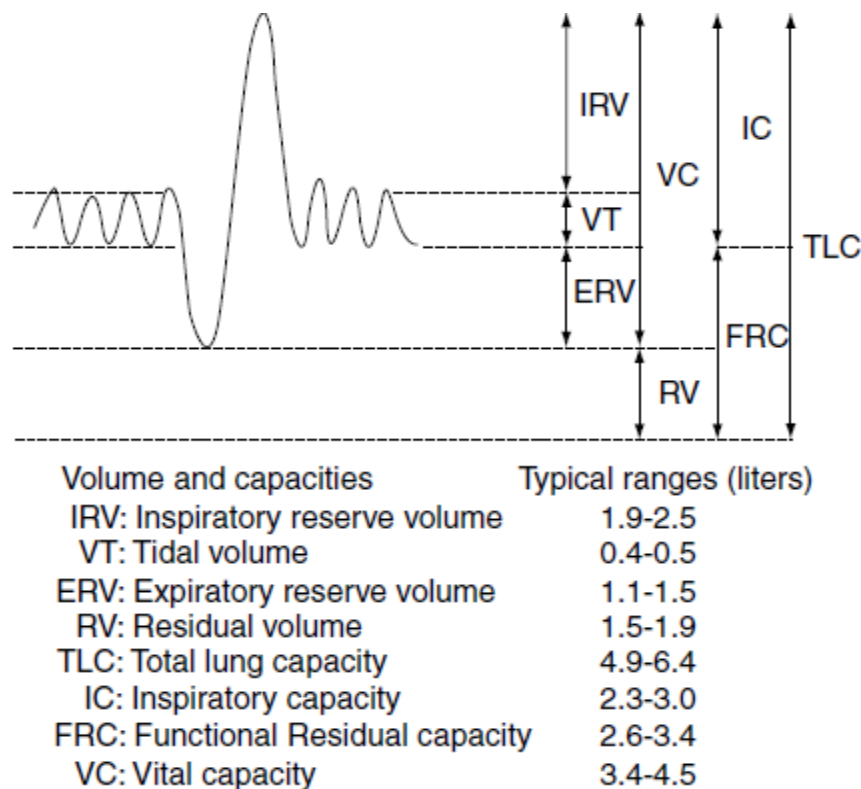

Figure 2-2: Standard lung volumes and capacities typical values for a 70-Kg adult are shown

2.3 Modelling of respiratory system:

Simulators and models of the respiratory system range from simple mechanical devices to complex systems that include sophisticated computers. Simulators and models are of 3 types: signs-and-symptoms simulators anatomic models, and physiologic models. Signs-and-symptoms simulators range from human actors to computer-controlled patient mannequins. . Anatomic modeling can simulate basic anatomy for training clinicians. Three-dimensional reconstruction of the airways, using real patient data, can help to plan therapy, understand the disease process, and warn of safety issues. Anatomic modeling with radiographs and magnetic resonance images, sometimes created using radio labeled tracer gases, can create 3-dimensional images of regional lung anatomy and function. Physiologic signals such as carbon dioxide production, oxygen consumption, and washout/washin of various tracer gases can be used to model ventilation-perfusion and ventilation volume relationships, and those models can improve understanding of disease processes and guide therapies.

Chapter 3 Literature Review

3.1 Literature Review of respiratory system:

The respiratory system (or ventilator system) is the biological system of an organism that introduces gases to the interior and performs gas exchange. The knowledge of the control mechanism will be very helpful for improving diagnostics and treatment of respiratory diseases. A number of dynamic models of the human respiratory system have been proposed since the 1950s. The equation of motion (EOM) is the commonly accepted mathematical model of the respiratory system which provides the basis for the most clinically applied methods of respiratory mechanics analysis.

M. Michnikowaki et al. (2008). The aim of this work is building a hybrid model of the human respiratory system which enables connecting the real clinical devices (respirators) with the computerized virtual lungs. A simulation of the artificial ventilation of lungs with the use of the hybrid model and the Siemens Servo 900 respirator was made. Waveforms of pressure inside the lungs, flow in the respiratory tract, and the lung volume during the simulated artificial ventilation were recorded. The compliance and resistance of the hybrid model of the respiratory system were calculated on the basis of the inspiratory pause algorithms and compared to the values set in the model. The initial tests have shown that the calculated values of the parameters differ by 20% (worst result) from the values set in the model. The model will enable the investigation of the different models of lung ventilation as well as educational presentation of the respirator–patient interaction.

Tinku Biswas et al. (2012) developed an electrical model which mimics two respiratory diseases. The electrical circuit is analogous to the actual anatomical structure of the breathing system and composed of the passive electrical components (R and C). The transfer function is derived from the electrical model. Different time domain responses are observed from the transfer function to study the alveoli and respiratory tract conditions for qualitative assessment of bronchitis (due to narrowed bronchial tubes) and emphysema (due to air pollutants, smoking etc...) for each of the diseases we have considered its three different qualitative stage or levels e.g. moderate, good and poor for productive analysis. The respiratory control system can also, under proper conditions, exhibit damped and sustained oscillation. Douglas and Haldane (1908) showed after a period of voluntary hyperventilation several cycles of damped oscillation often occur, and in the clinical abnormality known as Cheyne-Stokes respiration the system continually overshoots and undershoots the regulated level and, thus exhibits sustained oscillation. This study was designed to investigate the human respiratory control system, its purpose has been first, to derive the basic equations of the system and, secondly to investigate the system as biological regulator. This concept is not new, however the system has been analyzed mathematically only roughly. A simplified analysis was made by Grodins in 1954 in which CO₂ was the only controller of ventilation considered, the tissue elements were lumped in to a single reservoir, blood flow was held constant, and circulation time were considered to be infinitely short, Horgan and Lange (1963) added circulation time and oxygen control to this basic model in order to study periodic breathing. Defares et al (1960) extended Grodins model by dividing the tissue reservoir into two distinct compartment, brain and body tissue and considering cerebral blood flow as a function of arterial P_{co2}. However, the effects of oxygen as controller of ventilation and the effect at time delays in the transport of gases from the lungs to the two

tissue reservoirs were not considered in this model because of their unimportance to the CO₂ inhalation studies with which this model was concerned. These factors have all proved to be very important in describing the respiratory control system. They will be considered in detail in this analysis.

Maciej Kozaraki et al (2009) A design principle, construction and results of preliminary tests of a new hybrid physical electrical model of lungs mechanics has been presented. The methods leading to development of lungs models of different complexity have been also included. The basic component of the model is a voltage controlled flow source build up with a piston- cylinder system driven by a servomotor. This is used to develop a functional module playing a role of an impedance converter transforming an input electrical impedance Z_0 of any electrical network connected to its electrical terminals in to a pneumatic impedance Z_{in} . Static and dynamic characteristics of the model connected with the respirator (expiration by the respiratory valve) and for the model with free unobstructed expiration. The very good dynamic features (time constant of the piston flow source less than 1 ms) and small resultant error of impedance conversion (less than 1%) enable the model to be applied in many application especially when new methods of lung ventilation are developed.

M. Kozarski (2006). Use hybrid (physical-numerical) model of human respiratory system in optimization of ventilator support strategy. In our solution a numerical (computer) model of the lungs mechanics is connected to a respiratory by means of a special type of electro-pneumatic transformers of impedance. In this way, the virtual lungs with easily changeable mechanical parameters (airway resistance, alveolar capacitance) as parameters of a computer program are used to simulate lungs pathology and the respirator is adjusted to investigated ventilation methods. In this study various solution of electro pneumatic impedance transformers were considered and tested. These tests proved that the original hybrid model of respiratory system is a very suitable

tool for optimizing mechanical under conditions of mechanical ventilation assistance.

S .ganzert et.al (2007) derives the equation for model identification in respiratory mechanics under condition of mechanical ventilation. This was the first application of an equation discovery technique to measured respiratory data from intensive care medicine.

S.Sepehari (2007) developed physical based model of human respiration .He modeled the slow deep breathing by tunnel diode oscillator.

H. Zhu et al. (2007) demonstrates that predictive neural network may prove to be valuable as a tool in automatic mechanical ventilation support. In his study a method suitable for an adaptive continuous control of nonlinear pulmonary mechanics has been proposed .The method is based on the application of a neural network predictive control approach that incorporates the nonlinear mechanics of an individual patient. The mechanical status of the respiratory system in incubated mechanically ventilated patients is conveniently assessed from the dynamic relationships between the pressure and flow of gas measured at the entrance to the endotracheal tube by J.H.T. Bates and P.Goldberg (1999).A model of respiratory mechanics was fit to the data, and the parameters of the model are then taken to be measures of important physiological quantities. They showed that the respiratory system of the ARDS patient during normal mechanical ventilation exhibit significant nonlinear mechanical behavior that indicated a nonlinear dynamic pressure-volume relationship and non-linear behavior of the respiratory system in such patients may be important for protecting against possible barotraumas caused by increases in tidal volume.

M. Kuebler (2007) developed a two-component simulation model for respiratory mechanics. A comprehensive understanding of respiratory mechanics is pivotal for the accurate diagnosis and treatment of lung disease,

for adequate artificial or assisted ventilation, and for analysis of environmental effects, e.g. in diving or under hyperbaric conditions on lung mechanics and function. Yet, understanding of lung mechanics is difficult due to the complex and dynamic nature of pressure-volume relationship of the respiratory system. H.T. Milhorn et. Al. (1965) investigated the human respiratory control system by mathematical modeling. They derive the basic equations for respiratory control in the human being and to obtain transient and steady-state solutions for both positive and negative step input disturbances of inspired CO₂ and O₂ concentrations. An insight in to the importance of this type of analysis is given by the study of the effectiveness of the respiratory system as a regulator. Its purpose has been, first, to derive the basic equation of the system and, secondly, to investigate the system as a biological regulator. They assumed that the system consists of three reservoirs (the lung, the brain tissues, and the body tissues). Blood flow to the brain is dependent upon cerebral-arterial P_{co2} and P_{o2} which controls alveolar ventilation.

F.T. Tehrani (1997) developed a mathematical model for the respiratory system of infants at different stages of maturity, the effects of respiratory parameters on the infant respiratory response have been determined by simulation model. The analysis of infant respiratory system is helpful in early diagnosis of sudden infant death syndrome. The contributions of different mechanisms to particle deposition in local airway segments vary with effective particle size density, and local airflow rate and gravity angle. In 56 regions, where the Reynolds numbers are low.

L. Harrington et. Al. (2006) simulated trajectories of 1-5 micrometer particles in 3-D alveolated ducts representing generations 18-22 with different gravity angles. They concluded that the total deposition can be a function of the gravity angle and the ratio of the terminal settling velocity to mean lumen flow velocity. In summary, most of the computational analyses for gravitation deposition

focused on the alveolar region where sedimentation may play a dominant role. The effects of gravity on the aerosol deposition in the bronchial airway, especially in the medium – size airway where sedimentation and impaction may occur simultaneously, have been thoroughly investigated by C.Kleinstreuer et al. (2007).

The expiratory flow pattern during tidal breathing is the result of the continuing inspiratory muscle activity during the first part of expiration, expiratory muscle activity and the mechanical properties of the respiratory system. D.Walraven et al (2003) developed a mathematical model on physiological properties to describe the entire expiratory flow pattern in spontaneously breathing, anesthetized cats, Such a model requires besides modeling of the mechanical properties of the respiratory system at least description of the continuing inspiratory muscle activity in early expiration .As a result, the model fit to the data provides estimates for the relevant respiratory parameters.

Expiratory activity was not since it was usually absent or only present at end of expiration which part was then excluded from the model fit. It is good modeling practice not to use a more complicated model than needed to give a good fit of the measured data, and it turned out in that the simplest mechanical model of the respiratory system could be used for that purpose. This is the one compartment model characterized by the time constant of the respiratory system (TRS) which is the product of resistance (RRS) and compliance (CRS) of the respiratory system. The continuing inspiratory muscle activity was described by a sigmoid function characterized by another time constant. The derivation of all equation used is explained in the methods section. In this study the model provides an accurate description of the expiratory flow profile in anesthetized tracheostomies.

Cats during tidal breathing and that the parameter estimates obtained for TRS and Tmus are comparable with values obtained using different methods Jean Marie Ntaganda et.al.(2007). Design a mathematical model for determining blood pressures response to cardiac and respiratory parameters.

J.J.Batzel and H.T. Tran (2000) extend the model presented by Khoo et. Al. in 1991 to include variable delay in the feedback control loop and to study the phenomena of periodic breathing and apnea as they occur during quiet sleep in infant sleep respiration at around 4 months of age .The nonlinear mathematical model consist of a feedback control system of five delay differential equation .Numerical simulations are performed to study instabilities in the control system and the occurrence of periodic breathing and apnea in the above case which is a time frame of high incidence of sudden infant death syndrome (SIDS).

The maximum expiratory flow (MEFV) curve is a sensitive test of respiratory mechanics several mathematical model for forced expiration have been developed, but they suffer from various shortcomings .It is impossible to calculate the parts of the MEFV curve beyond the flow limiting conditions and computational algorithms do not allow a direct calculation of maximal flow.

Adam G.Polak (1998). Has been constructed a complex nonlinear forward model, including exciting signal and static recoil pressure lung volume descriptions and 132 parameters. Model for the driving pressure was:

$$P_d(v) = P_m$$

Where P_m in the maximal expiratory pressure that can be produced by muscles and elastic forces of the thorax , V_e is the vital capacity , t is the time constant , R_T is tissue resistance and Q is airflow.

It has been shown that lung heterogeneity plays an important role in respiratory system pathology and influences results of lung examinations. Experimental and model studies on the respiratory system demonstrate that heterogeneous

constriction of airways accompany asthma and can be a crucial determinant of hyper-responsiveness via an increase in lung impedance. Adam G. Polak (2003). Presented a computational model to predict maximal expiration through a morphometric-based asymmetrical bronchial tree. A computational model with the Hartsfield – like geometry of the airway structure, including wave speed flow limitation and taking into consideration separate airflow from several independent alveolar compartments has been derived. The airflow values are calculated for quasistatic conditions by solving a system of nonlinear differential equations describing static pressure losses along the airway branches. Calculations done for succeeding lung volumes result in the semi-dynamic maximal expiratory flow – volume (MEFV) curve.

This phenomenon has been described by Lambert et al using the momentum (static, incompressible flow case):

Where dp/dx is the gradient of lateral pressure along the bronchus, S_w is the local speed index equal to the ratio between flow (u) and wave (c) speed q is volume flow in the bronchus ρ denotes gas density A is the cross sectional area and ea/e_{ptm} in the elementary compliance of the airway wall dependent on transmural pressure.

Adam G. Polak (2008) again investigated a model based method for flow limitation analysis in the heterogeneous human lung. Flow limitation in the airway is a fundamental process constituting the maximal expiratory flow – volume curve. Its location is referred to as the choke point in this work, expressions enabling the calculation of critical flows in the case of wave-speed turbulent or viscous limitation were derived. Then a computational model for the forced expiration from the heterogeneous lung was used to analyse the regime and degree of flow limitation as well as movement and arrangement of the choke points. The conclusion is that flow limitation begins at similar time in

every branch of the bronchial tree developing a parallel arrangement of the choke points .A serial configuration of flow – limiting sites is possible for short time period in the case of increased airway heterogeneity. The most probable location of choke points are the regions of airway junctions. The assumption used is that a given flow corresponds to a unique volume and that we are able to measure flow more precisely than volume. The work to date looks encouraging, and I would predict that once flow volume curves are routinely handled in this manner, much of the variability that has plagued the evaluation of density dependence on inter- and intra-subject comparisons will be greatly reduced. These are only some of the challenges and opportunities that lie ahead. I would suggest that there is sufficient work to keep energetic imaginative investigators profitably occupied for many years.

Mashaer Ahmed, Fargoon Mohamed(2014)the electrical circuit that was designed simulate breathing and give out relatively close to normal breathing with amplitude 5cmH₂O and frequency .25Hz in software, and has been a change in resistance for abnormal results. The result obtained from the mechanical part return to the microcontroller, where it is compared with the value obtained from software if the value is lower or higher than the normal air pressure after that the microcontroller increase or decrease the speed of mechanical part and LCD display in air pressure versus speed.

Chapter 4 Methodology

The hybrid model of the respiratory system is consist of two part (soft rare and hardware).

4.1 Software:

The difference between the pressure inside the mouth and the chest, driving air flow can be simulated by a voltage V . Consequently air flow can be modeled as a current intensity (I) and the resistance to airflow through the airways can be represented as an electrical resistance(R). The Ohm's law:

$$V=RI..... (1)$$

Let us consider a simple model of pulmonary mechanics schematically shown in Figure (4-1).By applying significant simplification, the lungs can be viewed as three bags connected through two tubes. The lungs are connected to the ventilator of artificial pulmonary ventilation, which blows air into the lungs periodically under the pressure P_AO . P_0 is the pressure of ambient atmosphere. The air flow Q circulates through upper respiratory tract having the resistance R_C . From the upper respiratory tract, air struggles through the lower respiratory tract into alveoli. The resistance of the lower respiratory tract is R_P , the pressure in central parts of the respiratory tract (at the borderline of the upper and lower respiratory tract) is P_{AW} while pressure in alveoli is P_A . Consequently, an electrical model of the lung could be the following presented in Figure (4-2).

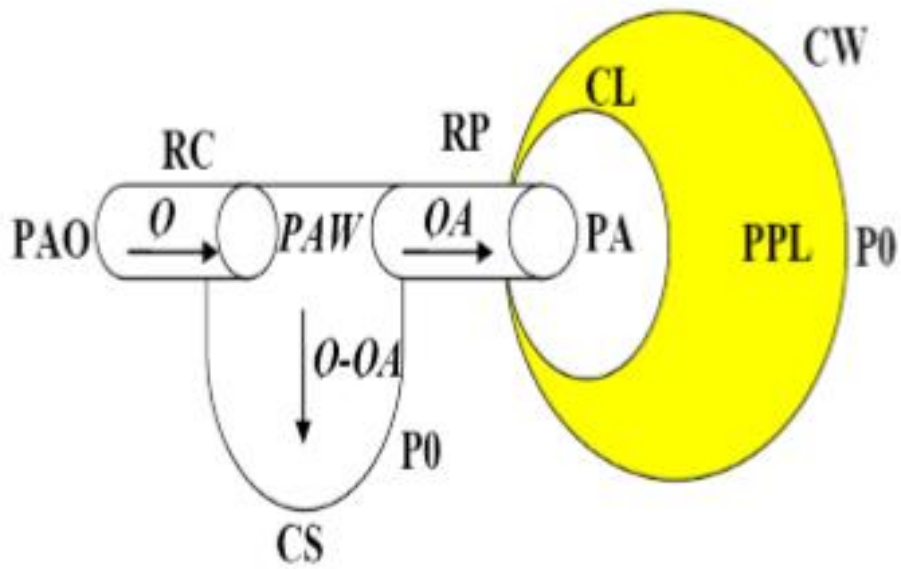

Figure 4-1 Lung Hydraulic model

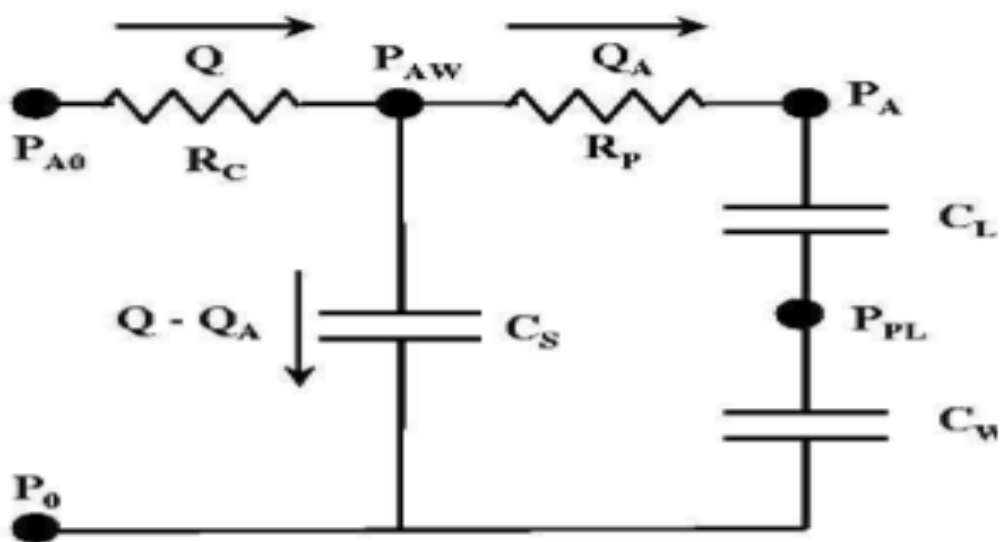

Figure 4-2 Lung Electrical model

Table 4-1 Physiological parameter

Parameter	Symbol
C_W	chest wall compliance
C_L	lung compliance
C_S	shunt compliance
R_P	peripheral airway resistance
R_C	central airway resistance
P_{ao}	pressure at airway opening
P_{pl}	pressure in pleural space
P_{aw}	pressure in central airway
P_A	pressure in alveoli
P_0	ambient pressure
Q_A	airflow in alveoli
Q	total airflow

Applying Kirchhoff first law on loop 1:

$$QRC + \frac{1}{CS} \int (Q - Q_A) dt + (P_0 - P_{A0}) = 0 \quad \dots\dots (2)$$

Applying Kirchhoff first law on loop 2:

$$R_P Q_A + \frac{1}{(C_L + C_W)} \int Q_A dt + \frac{1}{C_S} \int (Q - Q_A) dt = 0 \quad \dots\dots (3)$$

Differentiating equation (2) and (3) with respect to time:

$$\frac{d^2 P_{A0}}{dt^2} + \frac{1}{RPCT} * \frac{dP_{A0}}{dt} = RC \frac{d^2 Q}{dt^2} + \left(\frac{1}{CS} + \frac{RC}{RPCT} \right) \frac{dQ}{dt} + \frac{1}{(RPCT) \left(\frac{1}{CL} + \frac{1}{CW} \right)} \quad \dots\dots (4)$$

While entering the following numerical parameters of resistances (in the units: cm H₂O/L/sec) and elasticity (in the units: L/cmH₂O): RC=1; RP=0.5; CL=0.2; CW=0.2; CS=0.005 equation (4) becomes:

$$\frac{d^2 PA0}{dt^2} + 420 \frac{dPA0}{dt} = \frac{d^2 Q}{dt^2} + 620 \frac{dQ}{dt} + 4000 Q \quad \dots (5)$$

Obtaining Laplace transform to equation (5):

$$\frac{Q(s)}{PA0(s)} = \frac{s^2 + 420s}{s^2 + 620s + 4000} \quad \dots (6)$$

However, application of the Laplace transformation convert the differential equation in to an algebraic equation, which is generally easier to solve. The ratio of PA0(s) to Q(s) in equation is called the transfer function of the system in question. Employing this approach allows the convenient representation of the input-output characteristics of any linear system in block diagram form.

Although the use of Laplace transform and state-space modeling greatly simplifies the mathematical characterization of linear system, models that provide adequate representation of realistic dynamical behavior are generally too complicated to deal with analytically. In such complex situation, the logical approach is to translate the system block representation in to a computer model and to solve the corresponding problem numerically. However, a variety of software tools are available that further simplify the task of model simulation and analysis. One of these, named SIMULINK, is currently used by a large segment of the scientific and engineering community. SIMULINK provides a graphical environment that allows the user to easily convert a block diagram in to a network of blocks of mathematical function. It runs within the interactive, command-based environment called MATLAB. After we implement model in SIMULINK, we will select and drag the sine wave function generator in to working window. We will set the amplitude to 2.5 cmH₂O (peak-to-peak

swings in PA0 will be 5 cmH2O) and the frequency to 1.57 radians s^{-1} which corresponds to 0.25 Hz or 15 breaths min^{-1} connect the output port of the transferblock with a line. To view the resulting output Q.

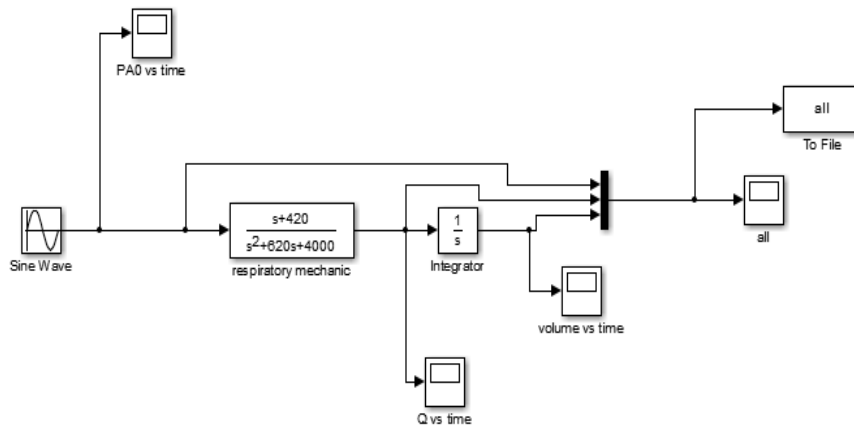

Figure (4-3) the design in SIMULINK

4.2 Hardware

Figure (4-3) show the block diagram of the whole setup. The arduino is programmed to control of motor, the motor is running the mechanical part. The mechanical part pump the air in the balloon and the pressure sensor detect air pressure inside the balloon. Arduino read the value of the sensor as feedback and then displayed on LCD.

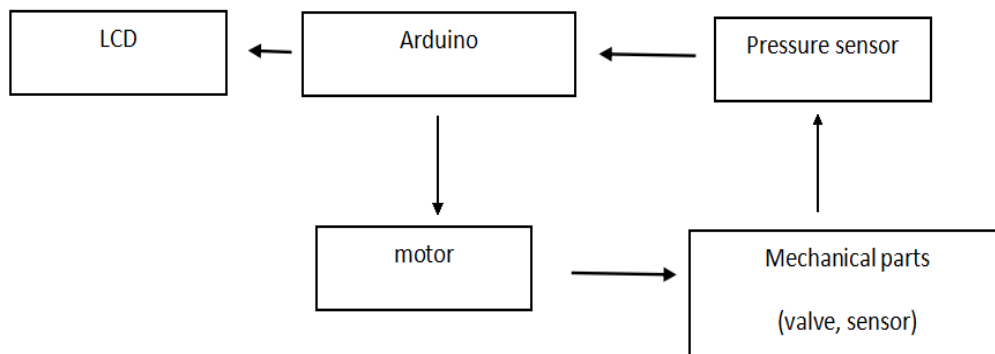

Figure 4-3 Block diagram of hardware

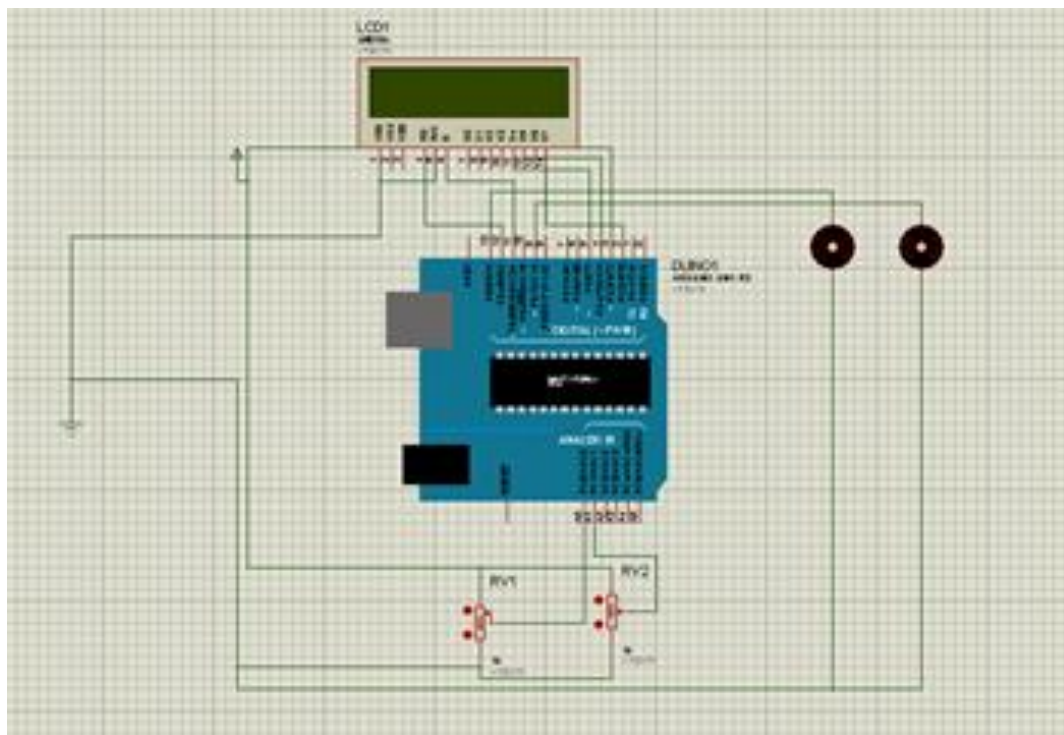

Figure 4-4 Proteus block diagram

```

final2
#include<LiquidCrystal.h>
const int pPin = A0;
const int rPin = A1;
int v1Pin=13;
int v2Pin=9;
float pReading;
float rReading;
float sub;
LiquidCrystal lcd(12, 11, 5, 4 ,3 ,2);
void setup() {
  // put your setup code here, to run once:
  pinMode(v1Pin,OUTPUT);
  pinMode(v2Pin,OUTPUT);
  lcd.begin(16,2);
}

void loop() {
  // put your main code here, to run repeatedly:
  digitalWrite(v1Pin,HIGH);
  delay(4000);
  digitalWrite(v1Pin,LOW);
  digitalWrite(v2Pin,HIGH);
  delay(4000);}
  digitalWrite(v2Pin,LOW);
  pReading=analogRead(pPin);
  rReading=analogRead(rPin);
  sub=(pReading-rReading);
  lcd.setCursor(0,1);
  lcd.print(sub);
}

Done compiling.

Sketch uses 4,334 bytes (13%) of program storage space. Maximum is 32,256 bytes.
Global variables use 83 bytes (4%) of dynamic memory, leaving 1,965 bytes for local variables. Maximum is 2,048 bytes.

```

Figure 4-5 Arduino codes

4.2.1 Arduino:

Arduino/Genuino Uno is a microcontroller board based on the ATmega328. It has 14 digital input/output pins (of which 6 can be used as PWM outputs), 6 analog inputs, a 16 MHz quartz crystal, a USB connection, a power jack, an ICSP header and a reset button.

Microcontroller	ATmega328P
Operating Voltage	5V
Input (recommended)	Voltage 7-12V
Input Voltage (limit)	6-20V
Digital I/O Pins	14 (of which 6 provide PWM output)
PWM Digital I/O Pins	6

Analog Input Pins	6
DC Current per I/O Pin	20 Ma
DC Current for 3.3V Pin	50 Ma
Flash Memory	32 KB (ATmega328P) of which 0.5 KB used by boot loader
SRAM	2 KB (ATmega328P)
EEPROM	1 KB (ATmega328P)
Clock Speed	16 MHz
Length	68.6 mm
Width	53.4 mm
Weight	25 g



4.2.2 (mpx2200D) pressure sensors:

The mpx2200 series devices are silicon piezoresistive pressure sensor or providing a highly accurate and linear voltage output directly proportional to applied pressure.

Feature:

- Temperature compensated over 0 c to +85c.
- +-25% linearity (mpx2200D).
- Easy to use chip carrier package option.
- Absolute, differential and gauge options.



4.2.3 LCD (LMB162AFC):

Display content:

- 16 char *2 row.
- Char.dot 5x8.
- Driving method 1/16 duty, 1/5 bias

Note:

1. Color tone may slightly change by temperature and driving condition.



4.2.4 TRANSISTOR H32 TIP 121:

Feature:

- Medium power linear switching applications.
- Complementary to tip125 / tip126 /tip126.



4.2.5 VALVE ZC-3H:

A solenoid valve is an electromechanically operated valve. The valve is controlled by an electric current through a solenoid.

Feature:

- 24 v.

-Pressure range.

-Media temperature.

-Opening/closing time.



4.2.6 Component and specifications:

-Valve zc-3h.

-Compressor motor.

-Mox2200db pressure sensor.

-Transistor h32 tip 121.

-Lcd LMP 162AFC.

-Arduino uno.

Chapter 5 Result and discussions

5.1 Results:

The first step we did it to generate sine wave to express flow and volume of air inside the lung by using MATLAB (SIMULINK). The output from Arduino was passed to mechanical part, then sense the value of the air pressure from mechanical part by pressure sensor (mpx2200db) and is returned to the Arduino and displays air on the LCD (LMB162AFC).

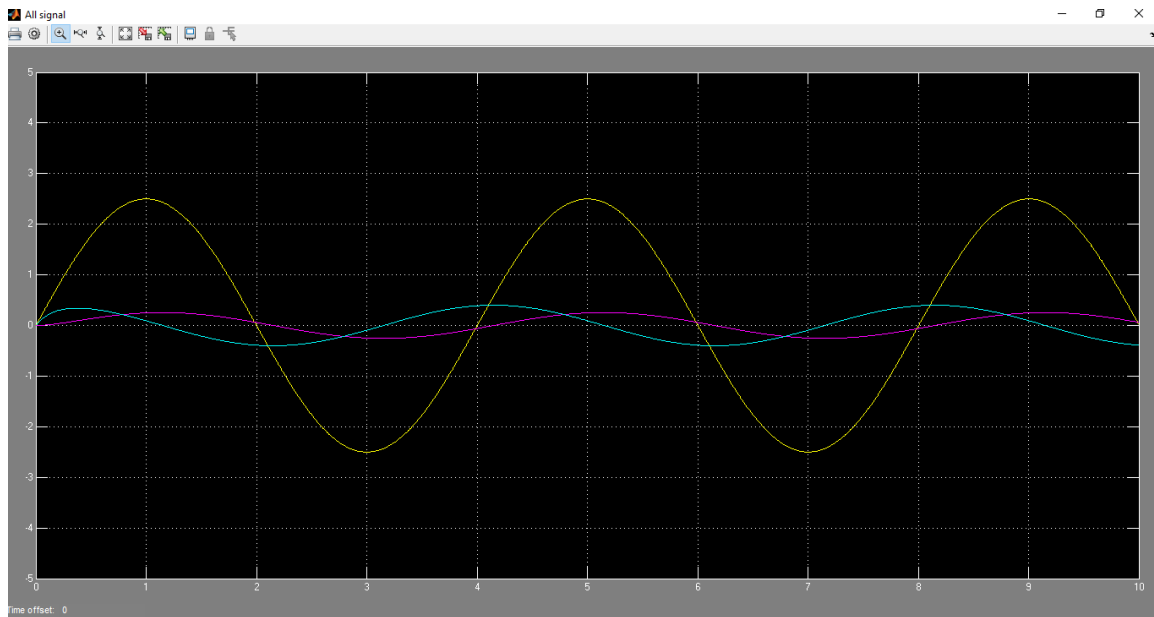

Figure 5-1 Simulation result from SIMULINK

- Pressure
- Flow
- Volume



Figure 5-2 hard ware

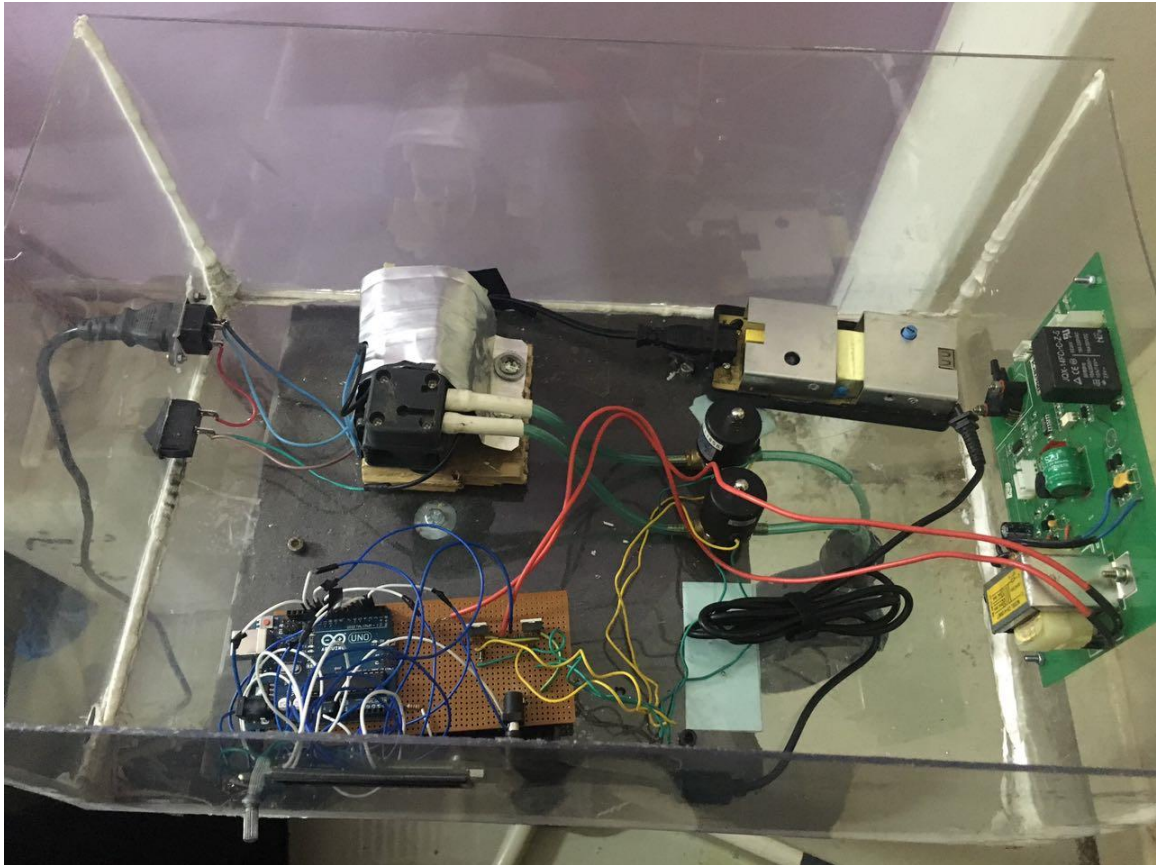

Figure 5-3 project circuit

5.2 Discussion:

In this project, the electrical circuit that was designed simulate breathing and give out result relatively close to normal breathing with amplitude 5cmH₂O and frequency 0.25Hz in software, and has been a change in resistance for abnormal result. The result obtained from the mechanical part return to the Arduino, where it is compared with the value obtained from software.

Chapter 6 Conclusion and recommendation

6.1 Conclusion:

The aim of the work was to design a simulator of the human respiratory system .mechanical parameters of the system and other parameter should be similar to the physiological ones, so that the simulator could be used for simulation of artificial ventilation of areal patient.

The design simulator is suitable for training in respiratory care, an educational device suitable for testing of the influence of the ventilator parameters upon the intrapulmonary condition similarly as during artificial lung ventilation of a patient.

6.2 Recommendation:

-Test this model in hospital by connect with mechanical ventilator to ensure output.

-improve the structure and parameter value of the current model and thus maximizing its potential as tool to assist in calibration of mechanical ventilator.

-development and change in the component of the device to reduce the size and increase efficiency.

Reference:

- [1] MARCIN MICHNIKOWSKI*, JAROSŁAW GLAPIŃSKI, MACIEJ GUĆ, TOMASZ GÓLCZEWSKI, MAREK DAROWSKI.
- [2] Snell, Snell clinical anatomy.
- [3] Concise, concise human physiology.
- [4] Neil R Macintyre MD FAARC Respiratory System Simulations and Modeling.
- [5] Otis AB, Mckerrow CB, Barelett RA, MEAD J, Mcllroy MB, Selver-stone NJ, Radford Jr EP: Mechanical factors in distribution of pulmonary ventilation, 1956.
- [6] Bates JK, Brown K A , Kochi T Respiratory mechanics in the normal dog determined by expiratory flow interruption , 1989.
- [7] Lambert RK: simulation of the effect of mechanical no homogeneities on flow from human lung, 1990.
- [8] Saladin, Kenneth s: anatomy and physiology: the unity of form and function. 5thed. New York: McGraw- hill, 2010.
- [9] Makenzie, b (2001): physiology-respiratory system [www] available from: <http://www.brianmac.co.uk/physiolr.htm>[accwssed, 1/10/2013].
- [10] ARTHUR C. GUYTON, M D; john E Hall, Ph.D.: Text Book of medical physiology, eleventh edition, 2006.