

2.1 Overview:-

This chapter introduces a general preview about color theory, the relationship between light and color and background about the components used.

Literature review and related works of historical systems are covered.

2.2 Background:-

2.2.1 Color Identification:-

Color names can be used and conjure reasonably consistent perceptions. There have eleven basic color names have been identified, namely; white, gray, black, red, yellow, green, blue, orange, purple, pink, and brown. Most or all colors can be described in terms of variations and combinations of these colors. Due to the fact that human color vision is accomplished in part by three different types of cone cells in the retina, it follows that three values are necessary and sufficient to define any color.

2.2.2 Color Theory:-

Berlien (2004) said that there have three values can be thought of as coordinates of a point in three-dimensional space, giving rise to the concept of color space. Hue, saturation, luminance (HSL) is one such color coordinate system, or color space. A more precise method of describing color is by hue, saturation, and lightness. Hue is the attribute of a color according to its similarity with one of the colors red, green, or blue, or a combination of adjacent pairs of these colors considered in a closed ring, as shown in figure 2.1.[1]

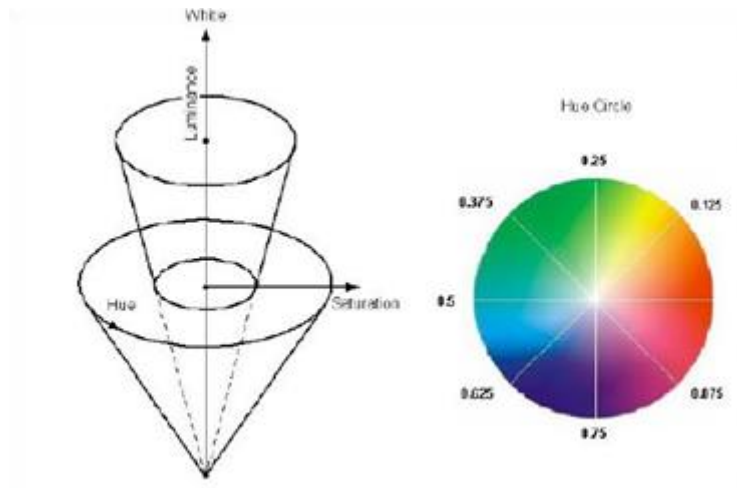

Figure 2.1: HSL diagram with Hue circle.

Another method describes color by hue, saturation, and value is HSV. HSL and HSV color spaces are nearly similar except that HSL assigns the high color values for colors that approaching to the white color with a bounded saturation while HSV assigns the high color values for colors that approaching to black. HSV color model is represented in a single cone as shown in figure 2.2.

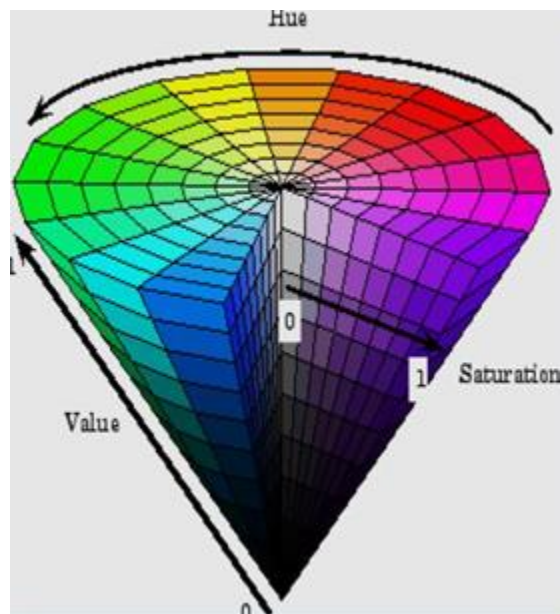

Figure 2.2: HSV color model single hex cone.

Color theory can also be defined by Soloman (1998). Color science defines color in a space, with coordinates of hue, saturation and intensity (HSI). Hue is related to the reflected wavelength of a color when a white light is shined on it. Intensity (lightness) measures the degree of whiteness or gray scale of a given color. Saturation is a measure of the vividness of a given hue. The term chromaticity primarily includes elements of hue and saturation components. Researchers depict color in space using hue as angle of a vector, saturation as the length of it and intensity as a plus or minus height from a center point as shown in figure 2.3.[2]

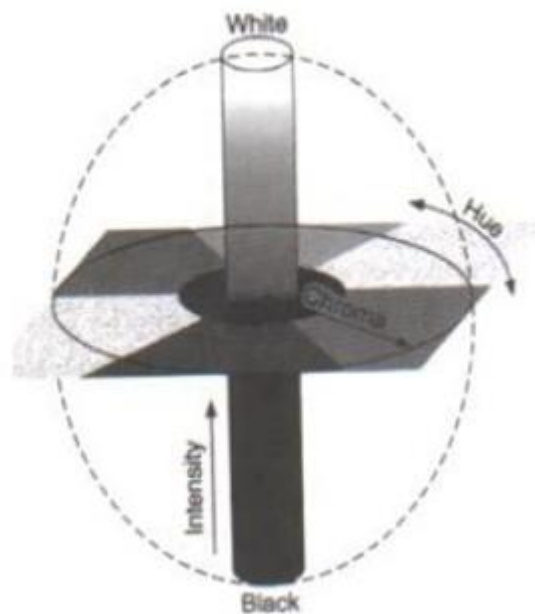

Figure 2.3: Coordinates of hue, saturation and intensity of color in space.

2.2.3 Color and Light:-

2.2.3.1 Definition of Light:-

Light is an electromagnetic radiation within a certain portion of the electromagnetic spectrum, the word usually refers to visible light, which is visible to the human eye and is responsible for the sense of sight. In physics, the term light sometimes refers to electromagnetic radiation of any wavelength, whether visible or not. In the sense, gamma rays, X-rays, microwaves and radio waves are also light.

2.2.3.2 Color Concept:-

A 'color' is an interaction between a very small range of electromagnetic waves and the eyes and brain of a person.

Color derives from the spectrum of light interacting in the eye with the spectral sensitivities of the light receptors. Color categories and physical specifications of color are also associated with objects or materials based on their physical properties such as light absorption, reflection, or emission spectra.

2.2.3.3 The Relationship between Color and Light:-

Color is a sensation of the brain, and the ability to see colors is only possible in the presence of light.

Sir Isaac Newton discovered that white daylight is actually made up of a spectrum of colors, namely; Red, Orange, Yellow, Green, Blue and Violet. It is only when light falls on an object that its characteristic color is seen and there are only three ways that an object interacts with light rays. When all the rays of light are absorbed human eye sees the color black; when all are reflected it sees white and when all but one are absorbed, it sees the color that is reflected.

An apple, for example, is red. Under white light, the apple appears red because it tends to reflect light in the red portion of the spectrum and

absorb light of other wavelengths. If a filter is used to remove red from the light source, the apple reflects very little light and appears black.

Each color has a unique wavelength that is processed and recognized in the eye and then transmitted to the brain. The rods and cones of the retina of the eye recognize the colors of light and degree of black and white thus making it possible to perceive the color characteristics of objects. The brain then translates this information to be perceived by the human eye. Hence, seeing is actually a function of the brain, as it is known that one can have perfectly healthy eyes but still be totally blind if the vision part of the brain is damaged.

Table 2.1: The visible colors and their corresponding range of wavelengths

Color	Wavelength Range (nm)
Violet	380 ~ 410
Indigo	410 ~ 450
Blue	450 ~ 510
Green	510 ~ 560
Yellow	560 ~ 600
Orange	600 ~ 630
Red	630 ~ 780

A factor that affects the quality of perception of color is illumination, or the level of light. Light that is too strong or too dim distorts and stresses vision and thus inhibits the ability to appreciate the true color characteristics of objects. Achieving the appropriate level of visual comfort is thus of paramount importance and is affected by the color scheme as well as the function of the space and the tasks performed in it, e.g. reading, watching television, eating...etc.

2.2.4 Color Sensor:-

Color sensors register items by contrast, true color, or translucent index. True color sensors are based on one of the color models, most commonly the RGB model. A large percentage of the visible spectrum can be created using these three primary colors. Depending on the sophistication of the sensor, it can be programmed to recognize only one color, or multiple color types or shades for sorting operations. Some types of color sensors do not recognize color intensity, instead focusing on light wavelengths.

2.2.5 Sorting:-

Sorting is any process of arranging items in some sequence and/or in different sets. It has two common distinct meanings such as ordering and categorizing. Ordering is arranging items of the same kind, class, nature, etc. in some ordered sequence while categorizing is grouping and labeling items with similar properties together. The main purpose of sorting information is to optimize its usefulness for specific tasks.

Various sorting tasks are essential in industrial processes. For example, during the extraction of gold from ore, a device called a shaker table uses gravity, vibration, and flow to separate gold from lighter materials in the ore (sorting by size and weight).

Other type of sorting is color sorting which is handled in this project.

Color sorting system is one of the useful systems in Industrial. It can be used to differentiate items based on the color of the item itself. Traditionally, the color sorting process is done by the operator manually. However, this method has some shortage such as increasing the cost of the product, slow production speed, and inaccuracy due to the human mistakes.

Simply, a color sensor is used to identify the color based on the reflected light from the object to be sorted. Then sends signals to a controller to continue the sorting process.

2.2.6 Application of color sorting systems:-

The following are five examples of systems uses color sorting techniques in different applications.

1. Sorting automotive parts with different colors:-

A manufacturer of automotive parts needs to differentiate parts whose only visible difference is a slight variation in color. One part is black, the other a dark grey. Because efficiency demands that the part be sorted at a high rate of speed, the opportunity for mistakes is extremely high. By using advance color sensing technology, the manufacturer can sort these parts at an enhanced rate of speed, saving time and virtually eliminating errors.

2. Assembly of medical closures with different color components:-

In this situation, containers of liquid medications consist of an aluminium cap with a plastic cover. A complete closure assembly requires the assurance of proper color combination of two components. Because of this absolute necessity of color accuracy, color sensing technology proves invaluable.

3. Lumber sorting by color:-

Color coding has become a standard method of differentiation in the lumber industry. Not only different types of lumber but the grade, quality and intended purpose of the lumber is indicated by color. Because the environments in which lumber is sorted can be highly abusive, it is recommended that protective covers be employed to protect the fiber optics used for this process.

4. Color sensing in the food industry:-

Sensing a white target on a white background is challenging using conventional photoelectric sensors. A manufacturer who needs to insure the presence of the white cap on a jar of mayonnaise improves accuracy with a color sensor that employs the RGB color concept. This technology improves the contrast between two slightly different whites.

5. Ammunition final inspection:-

An ammunition manufacturer codes the style and caliber of bullets with various colors on the tips. The need to insure that the proper type and caliber of product are correctly packaged necessitates the automation of the product line with color sensing technology. Because of the critical nature of this application, it is recommended that two color sensing stations be implemented to add an extra safety margin to the operation.

2.3 Literature Review and Related Works Covered:-

Bozma and Yal-cin (2002) in their journal explain about a Visual sorting setup in an industrial setting, typical setup is as shown in Figure 2.4. They state how items at random position to be moved on a conveyor. A camera located above the conveyor views the items orthographically. They assume that there is an item separator placed before the camera so that the incoming items are not overlapping which is a realistic assumption in many manufacturing environments. A sensing device signals the presence of perception that is instead of processing the whole image, only areas that are deemed “interesting” and thus calling for attention are analyzed.[2]

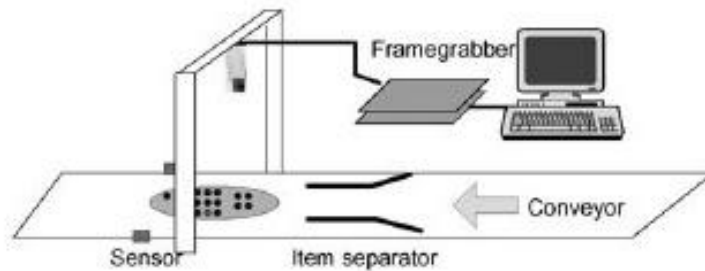

Figure 2.4: Visual sorting setup in an industrial setting.

The paper in [3] presents a smart approach for a real time inspection and selection of objects in continuous flow. The basic theme of this project is object flowing on conveyor are sensed, selected and sorted depending on their color. For this, camera is used as input to the microcontroller. Camera is mounted on PC and connected to it by USB. The camera takes a snap and feeds to PC for color processing. In PC MATLAB is used for processing on color, depending on this signal given to microcontroller Atmega 328. The microcontroller in turn controls the servomotors by PWM signals. These servomotors control

the movement of robotic arm, by controlling their angular movement. Thus the robotic arm is fully controlled by servomotors. The gripper of robotic arm picks the object and places it depending on its color.

This is a full automatic process no manual support is needed. The microcontroller used here is with the support of Arduino kit. The Arduino is a good platform for robotics application. It is the software and hardware also; using both the above system is developed. Thus the real time, continuous object sorting can be done.[3]

Trinesh, T. M. and Vijayavithal Bongale propose another way of sorting; the proposed system is an embedded system which increases the speed of color sorting procedure, provides the accurate color sorting process, decreases the cost of color sorting process and optimizes the productivity of an industrial object. The system comprises of color sensor, stepper, servo motors and microcontroller. It synchronizes the movement of robotic arm to pick the objects moving on a conveyor belt. It aims in sorting the colored objects which are coming on the conveyor by picking and placing them in their respective pre-programmed places. There by eliminating the monotonous work done by human, achieving accuracy and speed in the work. The project involves color sensors that senses the object's color and sends the signal to the microcontroller. The microcontroller sends signals to a circuit which drives the various motors of the robotic arm to grip the object and place it in the specified location. Based upon the color detected, the robotic arm moves to the specified location, releases the object and comes back to the original position. [4]

N.R.Vange et al introduced project about sorting with a robotic arm and the idea of sorting colored objects using a sensor and the arm. Also the idea of interfacing a wireless camera for monitoring the images. As the robotic arm is mounted on a base which has wheels helps the robot move from one place to other. The motors which drive the robot

and the arm are controlled with an RS232 interface. Also the color sensor used earlier, sense the red color even when some other color objects are presented.

The only problem was to find a controller and a sorting programming language which was simple, efficient and familiar as the entire control mechanism has to be user friendly. Intel 8051 microcontroller could easily be used but the problem was the slowness of the code execution which increased the output time. [5]

Color sorting robotic arm implemented by U.Amin et al have a capability to select the specified color object and place it at a desired location. At the beginning, when object is determined by the robot, the gripper of the robot picks the object and places it in the specified color differentiating station. The station consists of a color sensor named Light Dependent Resistor (LDR) which detects the light reflected by the body. TCS 3200 is an array arrangement of configurable silicon photodiodes and frequency converter mounted on the chip in the form of a CMOS integrated circuit on RGB color sensor. There is an 8*8 matrix of photodiodes in the sensor i.e. 64 filter sensors are used in it. The data collected from the sensor is converted into a square wave of 50% duty cycle by an oscillator integrated in the chip. This wave is then sent directly to the microcontroller. Microcontroller transfers signals to the motor drivers to activate the arm to pick the object and drop it to the place defined by programming of the controller. The arm rotates to the specific angle.[6]

A fully automated material handling system is produced by Dharmannagari Vinay Kumar Reddy. It has been done by using a pair of IR sensors interfaced with AT89S52 Microcontroller Unit. This robot involves color sensors that sense the object's color and send the signals to the microcontroller. The microcontroller sends signals to eight relay

circuit which drives the various motors of the robotic arm to pick the object and place it in the specified location. Based upon the color detected, the robotic arm moves to the specified position. [7]

The present paper in [8] relates to an apparatus and method for sorting small-sized objects, using electronic systems and advanced sensors operating on the basis of a physical and geometric characterization of each element. The project can work successfully and separates different objects using sensors. The sensor handling systems which drives the pick and place robot to pick up the object and place it into its designated place can. There are two main steps in sensing part, objects detection and recognition. The system may successfully perform handling station task, namely pick and place mechanism with help of sensor. Thus a cost effective Mechatronics system can be designed using the simplest concepts. The most common technology used in this project is image processing. The techniques developed for object recognition, MATLAB has the most powerful tool box for image improving, enhancing and categorizing different images using different features such as color, dimensions and texture of the object. Generally signal processing is used in the analysis of the color of an object. In this paper the detection of different colors is done through image processing technique using MATLAB. The Arduino microcontroller sends signals to the circuit which drives the various motors of the robotic arm to grip the object and place it in the specified location. Based upon the detection, the robotic arm moves to the specified location, releases the object and comes back to the original position.[8]

The project includes sensors that detect color of the object then sends the information to Arduino Uno which in turn adjusts the servo motor which located just below the ball slider to move it left and right.

Based upon the color detected, the slider moves according to the angle of 10°, 70° and 170° depending on the object's color. The stations are in red, green and blue respectively. After every ball placement, the slide goes back to its default angle position, awaiting the next color ball. [9]

Jones et al (1989), brief about color sorting system and method. Color sorting system and method is applied to sort fruits and vegetables. The objects to be sorted are scanned with a color video camera and the signals from the camera are digitized and utilized to addresses for colors to be rejected. In this system the data collected by camera are sent to color sorter processor to finalize the good or bad fruits or vegetables. If the objects are rejected, mean the object only have a certain number or sequence of unacceptable colors.

By referring to figure 2.5, the sorting apparatus of the present innovation has on preferred use in sorting moving items on a conveyor belt, which the items may be fruits or vegetables. A camera and flash allows for multiple images of the items or products on moving belt to be captured and processed by a color sorter processor. Color sorter processor which is in general controlled by a central processor unit or minicomputer is used to operate a rejecter unit. Timing as to be location of the item on the conveyor belt to provide for proper rejection is accomplished by timing feedback, which for example may be an output from a rotating pulse. Since all of the foregoing must be done on a real time basis and with a conveyor moving at high speed, the color sorter processor must receive the pictorial value from the camera and flash and process them. Typically, video camera charges coupled device which has a fast response time and it provides red, green and blue separate outputs. The present invention is also applicable to black and white cameras

which provide gray scale value. These require somewhat less processing time with the same equipment.[10]

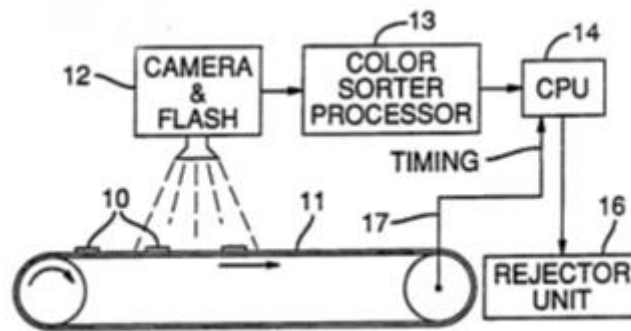

Figure 2.5: Block diagram of items on a conveyor belt being sorted by the apparatus.

2.4 Components:-

2.4.1 TCS3414CS color sensor:-

The TCS3414CS digital color light sensors are designed to accurately derive the color chromaticity and illuminance (intensity) of ambient light and provide a digital output with 16-bits of resolution. The devices include an 8×2 array of filtered photodiodes, analog-to-digital converters, and control functions on a single monolithic CMOS integrated circuit. Of the 16 photodiodes, 4 have red filters, 4 have green filters, 4 have blue filters, and 4 have no filter (clear).

The TCS3414CS devices can help:

- Automatically adjust the display brightness of a backlight to extend battery, increase lamp life, and provide optimum viewing in diverse lighting conditions.
- White-color balance display panel and/or captured images in diverse lighting conditions.
- Manage RGB LED backlighting to maintain color consistency over a long period of time.



Figure 2.6: TCS3414CS color sensor.

2.4.2 Arduino Uno:-

The Arduino Uno is a microcontroller board based on the ATmega328. It has 14 digital input/output pins (of which 6 can be used as PWM outputs), 6 analog inputs, a 16 MHz crystal oscillator, a USB connection, a power jack, an ICSP header, and a reset button. It contains everything needed to support the microcontroller; simply connect it to a computer with a USB cable or power it with an AC-to-DC adapter or battery to get started. The Uno differs from all preceding boards in that it does not use the FTDI USB-to-serial driver chip. Instead, it features the Atmega8U2 programmed as a USB-to-serial converter.

The Arduino Uno can be powered via the USB connection or with an external power supply. The power source is selected automatically.

External (non-USB) power can come either from an AC-to-DC adapter (wall-wart) or battery. The adapter can be connected by plugging a 2.1mm center-positive plug into the board's power jack. Leads from a battery can be inserted in the Gnd and Vin pin headers of the POWER connector.

The board can operate on an external supply of 6 to 20 volts. If supplied with less than 7V, however, the 5V pin may supply less than five volts and the board may be unstable. If using more than 12V, the voltage regulator may overheat and damage the board. The recommended range is 7 to 12 volts.

The ATmega328 has 32 KB of flash memory for storing code (of which 0.5 KB is used for the bootloader); it has also 2 KB of SRAM and 1 KB of EEPROM.

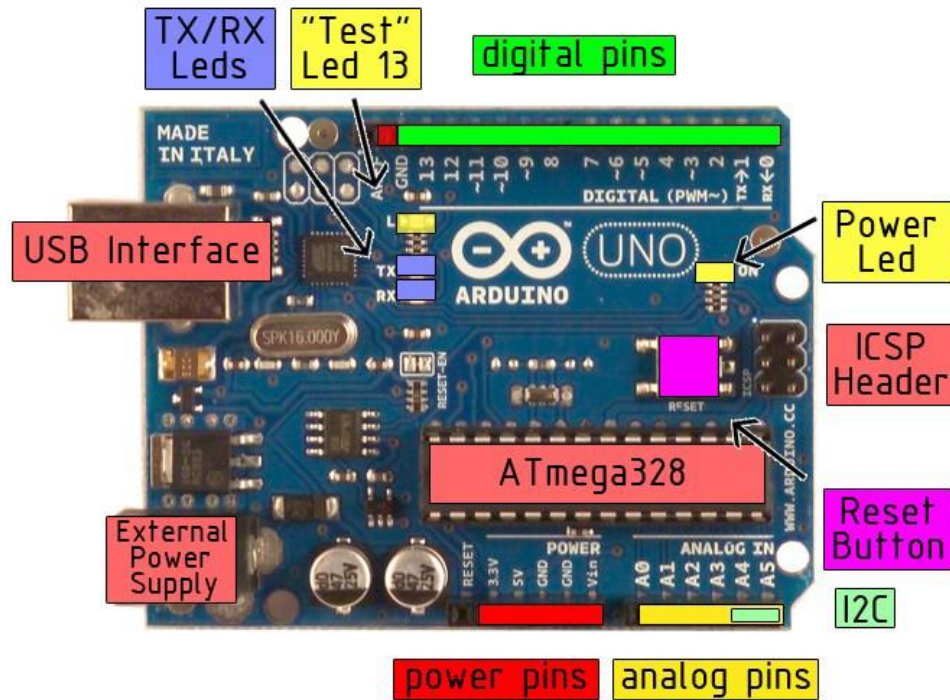

Figure 2.7: Arduino Uno.

2.4.3 Dc motors:-

Motors have several types like servo motors, and dc motors. A DC motor is any of a class of electrical machines that converts direct current electrical power into mechanical power. The most common types rely on the forces produced by magnetic fields. Nearly all types of DC motors have some internal mechanism, either electromechanical or electronic; to periodically change the direction of current flow in part of the motor. Most types produce rotary motion; a linear motor directly produces force and motion in a straight line. A DC motor's speed can be controlled over a wide range, using either a variable supply voltage or by changing the strength of current in its field windings.

In a typical DC motor, there are permanent magnets on the outside and a spinning armature on the inside. The permanent magnets are stationary, so they are called the stator. The armature rotates, so it is called the rotor.

The armature contains an electromagnet. When electricity is supplied to this electromagnet, it creates a magnetic field in the armature that attracts and repels the magnets in the stator. So the armature spins through 180 degrees. To keep it spinning, poles of the electromagnet have to be changed. The brushes handle this change in polarity. They make contact with two spinning electrodes attached to the armature and flip the magnetic polarity of the electromagnet as it spins.

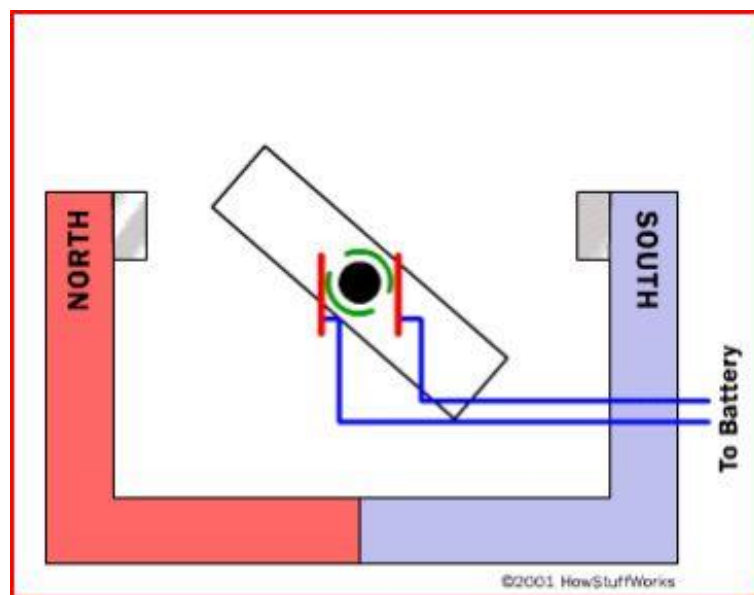

Figure 2.8: Working principle of DC motor.

Normal DC motors require current greater than 250mA. The Arduino Uno cannot supply this amount of current. There is a need of a circuitry that can act as a bridge between the Arduino Uno and the motors to provide the required current. There are several ways of making it, some of them are mentioned below:

1. Interfacing using Transistor.
2. Interfacing using relays.
3. Interfacing using L293D/L298.

The driver used in this project is L293D as described below.

2.4.4 L293D DC motor driver:-

L293D is dual H-bridge motor driver ICs. It can control the rotation of two motors in both clockwise and anti-clockwise direction.

The pin-out of the IC is shown below:

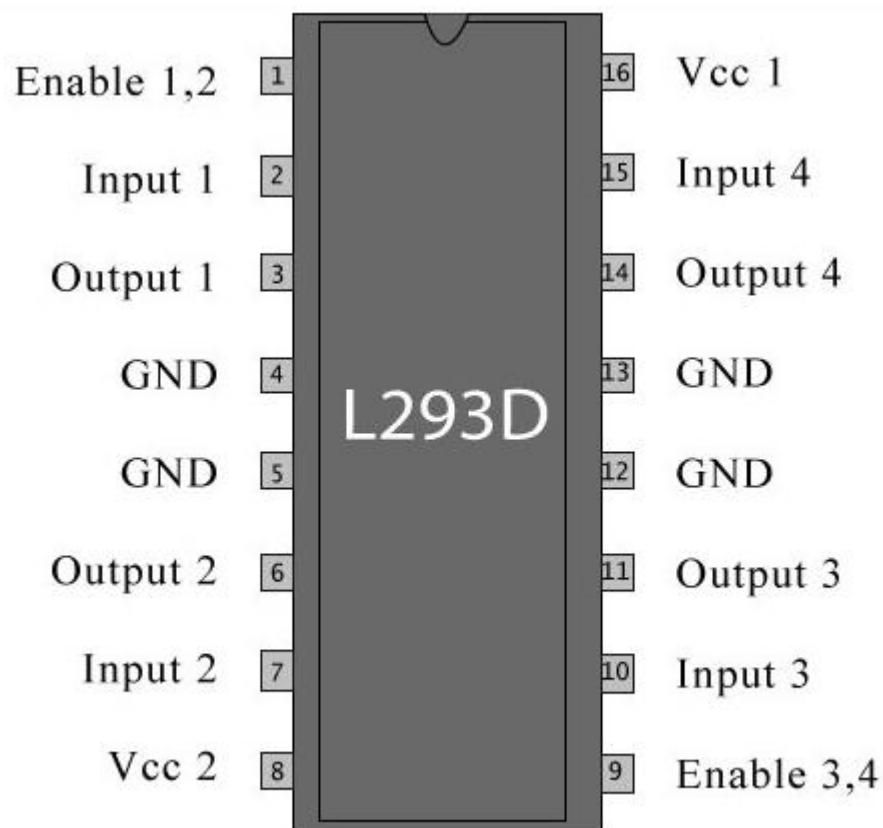

Figure 2.9: The pin-out of the l293D.

- **Enable pins:** These are pin 1 and pin 9. Pin 1 is used to enable Half-H driver 1 and 2. Pin 9 is used to enable H-bridge driver

3 and 4. These pins can also be used to control speed of the motor using PWM technique.

- **VCC1:** This is pin 16 used to supply power. Connect it to 5V supply.
- **VCC2:** This is pin 8 used to supply motor with power. Apply +ve voltage to it as per motor rating.
- **GND:** These are pins 4, 5, 12, 13 must be connected to the common GND of circuit.
- **Inputs:** These are pins 2, 7, 10, 15 are input pins through which control signals are given by microcontrollers or other circuits/ICs.
- **Outputs:** These are pins 3, 6, 11, 14 used as outputs pins. According to input signal output signal comes.

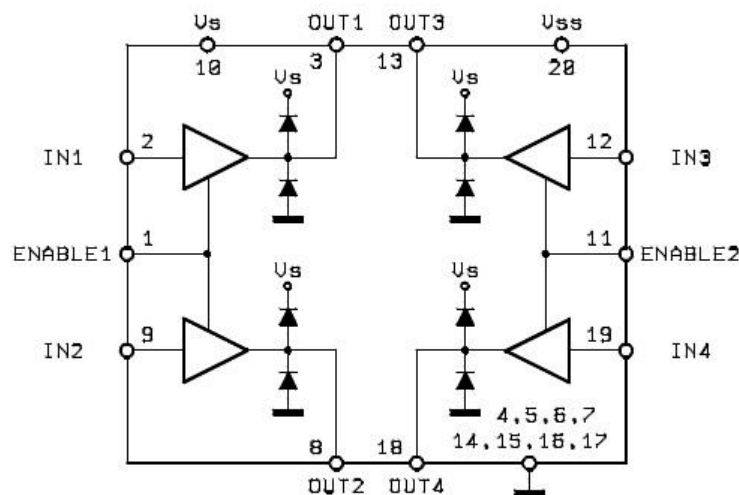

Figure 2.10: Circuit diagram of L293D.

The driver provides outputs to move the motor according to the input signals. These actions are shown in the table below.

Table 2.2: operation of l293D

Input 1	Input 2	Output 1	Output 2	Motor Status
Logic 0	Logic 0	0	0	Stop
Logic 1	Logic 0	+Ve	0	Clockwise
Logic 0	Logic 1	0	+Ve	Anti-clockwise
Logic 1	Logic 1	+Ve	+Ve	Brake

2.4.5 Servo motor:-

A servomotor is a rotary actuator that allows for precise control of angular position. It consists of a motor coupled to a sensor for position feedback.

Servo motors are controlled by sending an electrical pulse of variable width, or pulse width modulation (PWM), through the control wire. There is a minimum pulse, a maximum pulse, and a repetition rate. A servo motor can usually turn 90 degrees in either direction for a total of 180 degree movement. The motor's neutral position is defined as the position where the servo has the same amount of potential rotation in the both the clockwise or counter-clockwise direction. The PWM sends to the motor determines position of the shaft, and based on the duration of the pulse sent via the control wire; the rotor turns to the desired position. The servo motor expects to see a pulse every 20 milliseconds (ms) and the length of the pulse determines how far the motor turns. For example, a 1.5ms pulse makes the motor turn to the 90-degree position. Shorter than 1.5ms keeps the servo motor in 0 degree and any longer than 1.5ms turns it to 180 degrees.

When these servo motors are commanded to move, they move to the position and hold that position. If an external force pushes against the servo motor while it is holding a position, the servo motor resists from moving out of that position. The maximum amount of force the servo motor can exert is called the torque rating of the servo. Servo motors do not hold their position forever though; the position pulse must be repeated to instruct the servo motor to stay in position.

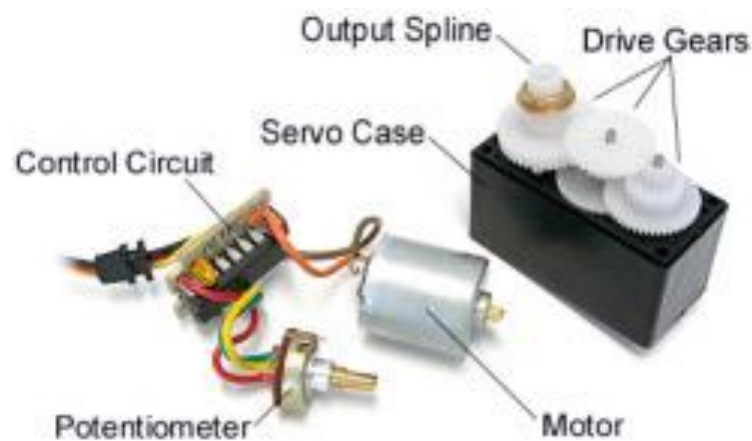

Figure 2.11: Servo motor.