

CHAPTER TWO

LITERATURE

REVIEW

2.1 Introduction:

Variation in wind speed, direction and temperature, over both time and space make it difficult to harnessing any appreciable portion of a tremendous wind energy source with reasonable economic costs. [1]

Wind energy storage and transmission are the most costly aspect of wind energy system Today's wind turbines are huge compared to those of even a decade ago. And the trend is toward manufacturing still larger machines. Although it May not appear so, wind turbines are complicated machines to control, particularly if high performance and good efficiency are needed. The safe and high Performance of these machines is possible only through technological Progress in control systems, electronics, communications, And the like, and Their integration with the laws of mechanics that govern the behavior of such Machines Understanding the rules of nature and the behavior of a wind turbine, and The ways its operation can be regulated as desired, is called "wind turbine technology." This is a subject that requires a number of types of specialized knowledge, which one needs to know in order to understand how wind turbines Operate, to work on them, and to carry out further research and development on their functionality the material related to wind turbines is plentiful. During the past 30 years a lot of work has been carried out on the associated topics, all of which cannot be included in a monograph. [3]

2.2 Historical background:

Wind and water have long been two main sources of energy for humanity Water mills and windmills have been used for applications such as wheat grinding and irrigation, where animals would otherwise have been used as the power Source. Before the invention of steam engines and conversion of energy from Burning coal and later oil, energy from wind was probably the only way long-distance sea transportation could be made possible Early reports and ruined remains of vertical-axis (its axis of rotation is Vertical) Persian windmills can be traced back 1000 years. The e famous Dutch Windmill, with a horizontal axis (its axis of rotation is horizontal), existed since the twelfth century The new era of interest in wind turbines for generating electricity started In the 1970s. The oil crisis in 1972 was a

good stimulation. European countries were more affected than other countries and placed full attention on this Renewable source of energy. Up until 1992, commercial wind turbines were much smaller (225 kilowatts), but as a result of technological progress, by the End of 2002 turbine size had grown by a factor of 10. More and more inland and offshore wind farms were developed in European Countries, and in North America attention to renewable energy was brought back. [3]

The earliest recorded English wind turbine is dated at 1191.the first corn-grinding wind turbine was built in Holland in 1439.there were a number of technological developments through the centuries, and by 1600 the most common wind turbine was the tower mill. The word mill refer to the operation of grinding or milling grain. This application was so common that all wind turbine were often called windmills even when they actually pumped water or performed some other function. We will usually use the more general terms wind turbine or wind machine rather than windmill, unless the application is actually that of grinding grain. [1]

The tower mill had a fixed supporting tower with a rotatable cap which carried the wind rotor. The tower was usually built of brick in a cylindrical shape but was sometimes built of wood, and polygonal in cross section. In one style, the cap had a support or tail extending out and down to ground level. A circle of posts surrounded the tower where the support to touched the ground. The miller would check the direction of the prevailing wind and rotate the cap and rotate in to the wind with which attached between the tail and one of the posts. The tail would then be tied to a post to hold the rotor in the proper direction this process would be repeated when the wind direction changed. Protection from high winds was accomplished by turning the rotor out of the wind or by removing the canvas covering the rotor latticework. The optimization of rotor shape took a long time to accomplish. It is in testing to note that the rotor on many of the Dutch mills are twisted and tapered in the wind energy system by Dr. Gary. Johnson October 10, 2006. [3]

2.3 Wind formation:

The formation of wind stars due to unequal heating the earth surface by the sun rays. [4]

In the daylight time oceans and lakes surfaces relatively cold because most of the sun power is used to evaporate water or stored inside the water but in the earth surface is largely heated and that because of the little amount of the power

absorbed by the earth surface compared to the power absorbed by the oceans and lakes , also the amount of heat absorbed in the water evaporation is so little , so most of the sun power is absorbed in air heating process , so the air expands and density decreases , so air will get higher causing a low pressure area , at the same time a high pressure area is made in oceans and lakes surface ,forcing the air to move according to the pressure difference. [4]

During the night the earth surface temperature decrease rapidly, compared to other water surfaces which dissipate heat slowly, and then lower pressure area will be formulated in water surfaces area, and the pressure increases in the land and once again the wind moves from high pressure area to the low pressure area. [4]

2.4 wind speed variation:

The wind speed is the most influential factor to how much power of a wind turbine can generate. . In fact, for any wind energy project the Wind speed is the first decision making factor. The nature of wind is that it is Variable. This implies its direction, speed, and temperature can change. This change can be from minute to minute or sometimes from second to second. So it is interesting and necessary to investigate the variation of wind speed. [1]

There are four categories of wind speed variation that we are going to Study. These are:

- Wind speed variation with time
- Wind speed variation with height
- Wind speed variation with terrain
- Wind speed variation with geographic zone

2.4.1 Wind speed variation with time:

The variation of wind speed with time, by itself, falls into three categories momentary changes, daily changes, and seasonal changes, Wind is generated by a difference in temperature of air between two locations. So, it is subject to the heat from sunshine and the temperature of the surroundings in an area of the Earth. We can sometimes clearly see this variation of wind and notice that wind does not blow with a constant speed. This momentary variation can be clearly seen when the wind speed is recorded. [1]

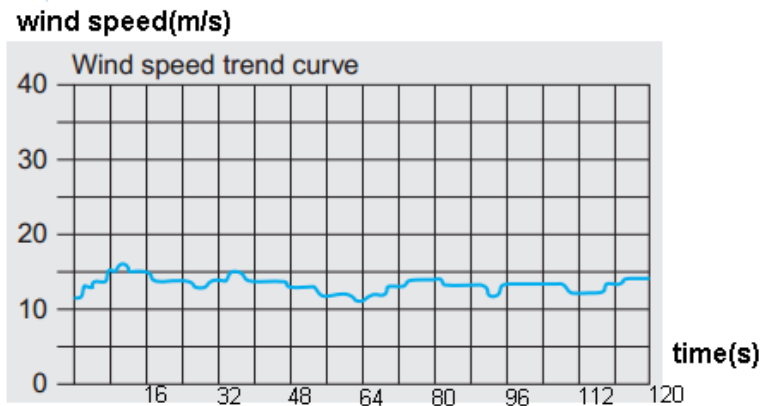

Figure (2.1) show a typical variation of wind in 2 min [1].

In figure (2.1) each division on the horizontal axis represents 8 sec, The Numbers on the vertical axis are in meters per second , The daily changes of wind speed, as the name implies, is the variation of wind speed in 24 hours. For instance, in one region the highest wind Speed can occur at a certain time of the day, and at other hours there is less wind or even no wind. In other words, we may be able to identify a specific pattern for wind in a region for various times of the day. Note that this could also be true for the direction of wind. [1]

Again, for this case one may find a specific pattern for the wind speed for various months of the year. The best example is that in many regions we have more wind in the spring or winter compared to the summer. This information must be found from statistical data of wind history, called wind data this information shows, also, that one cannot expect the same production of power from a turbine at different seasons in a year.[1]

2.4.2 Wind speed variation with height:

In addition to the change in wind speed with time, the speed of wind is not the same at different heights. As we move away from the Earth's surface the speed of wind gets higher. [1]

2.4.3 Wind speed variation with terrain:

When wind blows, its direction and speed are influenced by all the obstructions that lie on its path. At a height sufficiently away from the ground surface, however, wind direction and speed are not disturbed and there is a steadier wind stream. All the obstacles to the flow of wind can slow it down. Thus, inside cities where there are many buildings, there is more obstruction to slow down the wind. On the contrary, in farmlands with short vegetation's or along the surface of a lake there is not much obstruction to slow down the wind. [1]

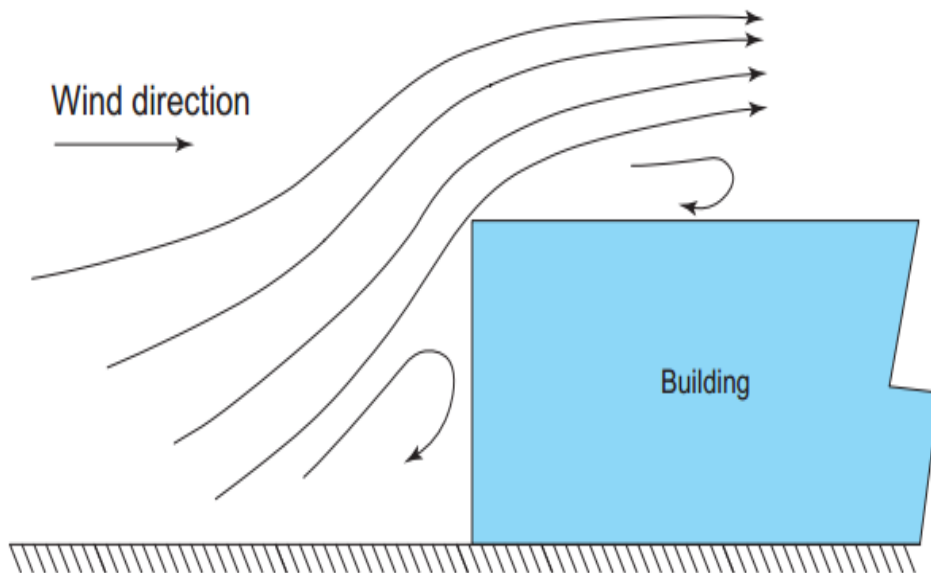
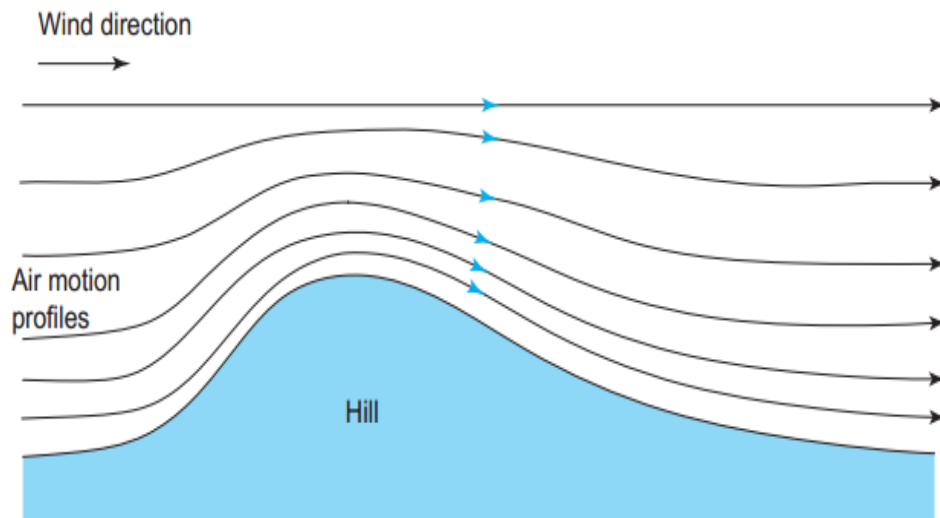

Figure (2.2) show any building is an obstacle to the wind flow; the effect slows the wind. [1]



Show the Profiles of wind passing over a hill. [1] Figure (2.3)

2.4 .4 Wind speed variation with geographic zone:

The most obvious observation that one can make is that climate is not the same everywhere. The formation of wind is affected by the change in the temperature and, pressure of air. The cooling down or warming up of a region depends on a number of factors, all related to the geographic location. For example, if a Region is near the sea or surrounded by mountains, whether or not it is affected by large storms, and so on, determine the wind specifications. One region is windier than others.

2.5 Wind energy potential in Sudan:

The objective of creating wind data base for Sudan are to:

- Analysis the wind energy potential in Sudan using available wind data for the country.

- Define recorded data and develop an accurate estimate of global wind energy available in Sudan.

Table (2.1) show results of Weibull parameters for number of station. [2]

Station	Altitude	Annul wind speed (V) m/s
Wade half	190	4.6
port Sudan	5	5
Karim	250	4.7
Atbara	345	4.2
Shabbat	380	4.8
Khartoum	380	4.8
Kassel	500	4
Wad madam	405	4.8
El fisher	733	3.4
El genuine	805	3.1

El obeyed	570	3.4
Kostas	380	4.0
Abu Navami	445	3.1

2.6 Wind turbine classification:

While many people think that wind turbine means a three-blade rotor on top of a tower, there are other types of wind turbines that can catch energy from wind. When air flows around an object, two forces act on the object, drag and lift. Accordingly, we have turbines that work based on either of these forces. Thus, in general, we have lift-based (or lift-type) turbines and drag-based (or drag-type)

turbines, this categorization is based on the type of active force that makes the turbines turn. [1]

Turbines can also be classified based on their axis. Whether it is horizontal or vertical. Axis here refers to their main shaft about which the rotating parts revolve. In this sense, a wind turbine can be classified as a horizontal-axis wind turbine (HAWT) or a vertical-axis wind turbine (VAWT). [1].

2.6.1 Horizontal axis wind turbine (HAWT):

Horizontal axis wind turbines also shortened to HAWT, A HAWT has a similar design to a windmill; it has blades that look like a propeller that spin on the horizontal axis. Horizontal axis wind turbine have the main rotor shaft and electrical generator at the top of a tower, and they must be pointed into the wind. Small turbines are pointed by a simple wind vane placed square with the rotor (blade) while large turbine generally use a wind sensor coupled with a servo motor. Most large wind turbines have a gearbox, which turns the slow rotation of the rotor into a faster rotation that is more suitable to drive an Electrical generator.[3]

Since a tower produces turbulence behind it, the turbine is usually pointed upwind of the tower. Wind turbine blades are made stiff to prevent the blade from being pushed into the tower by high winds. Additionally, the blades are placed a considerable distance in front of the tower and are sometimes tilted up a small amount. Downwind machine have been built, despite the problem of turbulence, because they don't need an additional mechanism for keeping them in line in the wind, and because in high winds, the blades can be allowed to bend which reduces their swept areas and thus their wind resistance. Since turbulence leads to fatigue, failures and reliability is so important, most HAWT are upwind machines. [1]

2.6.1.1 Type of horizontal axis wind turbine:

2.6.1.1.1 Single wing fan:

It reduces the cost and weight of the turbine. These are used due to tower shadow effect, needs counter weight on the other side of the blade, less stability.



Figure (2.4) show single wing blade

2.6.1.1.2 Double fan blade:

It requires more complex design due to sustain of wind shocks. It is also less stable, it saves the cost and weight of one rotor blade.



Figure (2.5) show double blade wind turbine

2.6.1.1.3 Triple fan blade:

Modern wind turbines uses three blade concept, because this structure have high strength to withstand heavy wind storm, less effect due to tower shadow , produces high output.



Figure (2.6): show triple fan blade

All horizontal axis wind turbine can be mounted in two ways as far as the wind direction is concerned: upwind and downwind. In the up-wind configuration, blades are in front of the tower, whereas in the downwind configuration wind hits the tower before it reaches the turbine blades. In practice, the two configurations are not the same, because of the effect of the tower on the flow of wind.

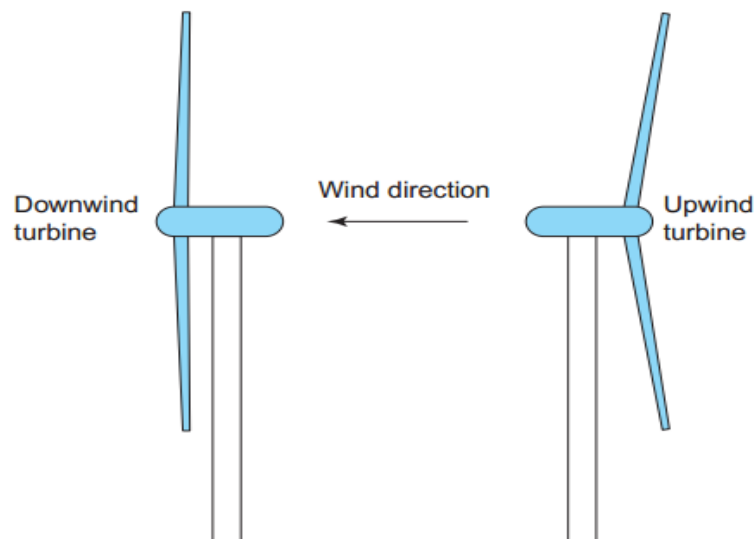

Figure (2.7) show two different installation designs for horizontal wind turbine. [1]

2.6.1.2 Advantages of the HAWT:

- The tall tower base allows access to stronger wind in sites with wind shear. In some wind shear sites, every ten meters up the wind speed can increase by 20% power and the output by 34%.
- High efficiency, since the blades always moves perpendicularly to the wind, receiving power through the whole rotation.

2.6.1.3 Disadvantages of the HAWT:

- Massive tower construction is required to support the heavy blades, gearbox, and generator.
- Component of a horizontal axis wind turbine (gearbox, rotor shaft, and brake assembly) being lifted into position.
- Their height makes them obtrusively visible across large areas, disrupting the landscape and sometimes creating local opposition.
- Downwind variants suffer from fatigue and structural failure caused by turbulence when a blade passes through the towers wind shadow (for this reason, the majority of HAWTs use an upwind design, with the rotor facing the wind in front of the tower).
- HAWTs require an additional yaw control mechanism to turn the blades toward the wind.
- HAWTs generally require a braking or yawing device in high winds to stop the turbine from spinning and destroying or damaging itself.

2.6.2 Type of vertical axis wind turbine:

2.6.2.1 The H-rotor:

An H-rotor is a vertical-axis wind turbine in the shape of H. The two vertical segments of the letter H are the active blades, which are connected to the Shaft by the middle segment. The two blades have the form of an airfoil and the turbine works based on lift force. The schematic of this type of turbine is shown in

Figure (2.6). Since this turbine has a vertical axis, it is not sensitive to wind direction. The two lift forces on the two blades of an H-rotor generate a torque about the turbine shaft that rotates the turbine. [1]

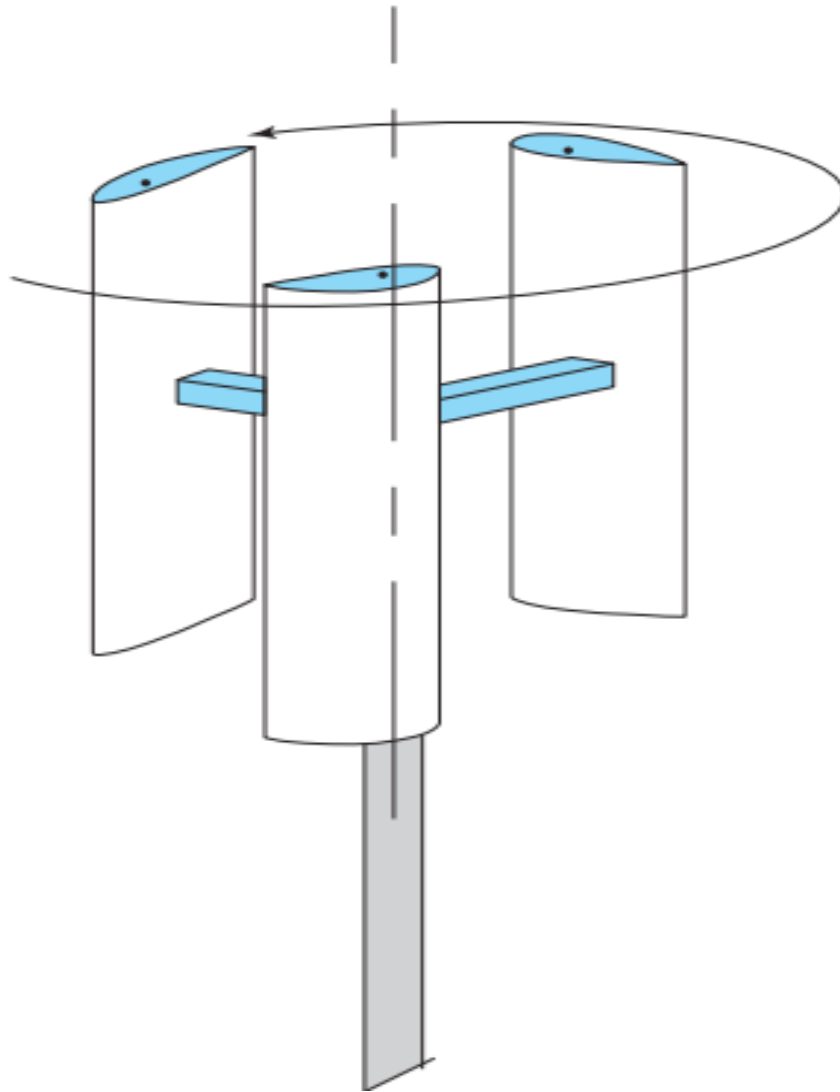

Figure (2.8) show a three-blade H-rotor. [1]

2.6.2.2 Darrius turbine:

A Darrius turbine or Darrius machine is more or less similar to an H-rotor, its having a vertical axis and working based on lift forces on the blades it has the shape of an egg beater. Instead of the blades being attached to the shaft in the center, they are continued from both up and down and are curved. The blades are

attached to the shaft at both ends. The curvature of the blades allows the vertical Shaft to be supported by a number of guy wires. In this sense, the main tower supporting the turbine shaft does not need to be as solid and strong as it must be in an H-rotor. [1]

A disadvantage of a Darrius machine is that it does not have a good starting torque. This means that at low wind speeds it cannot easily start to rotate. After it starts rotating, however, it has a good torque and can continue to generate electricity. [1]

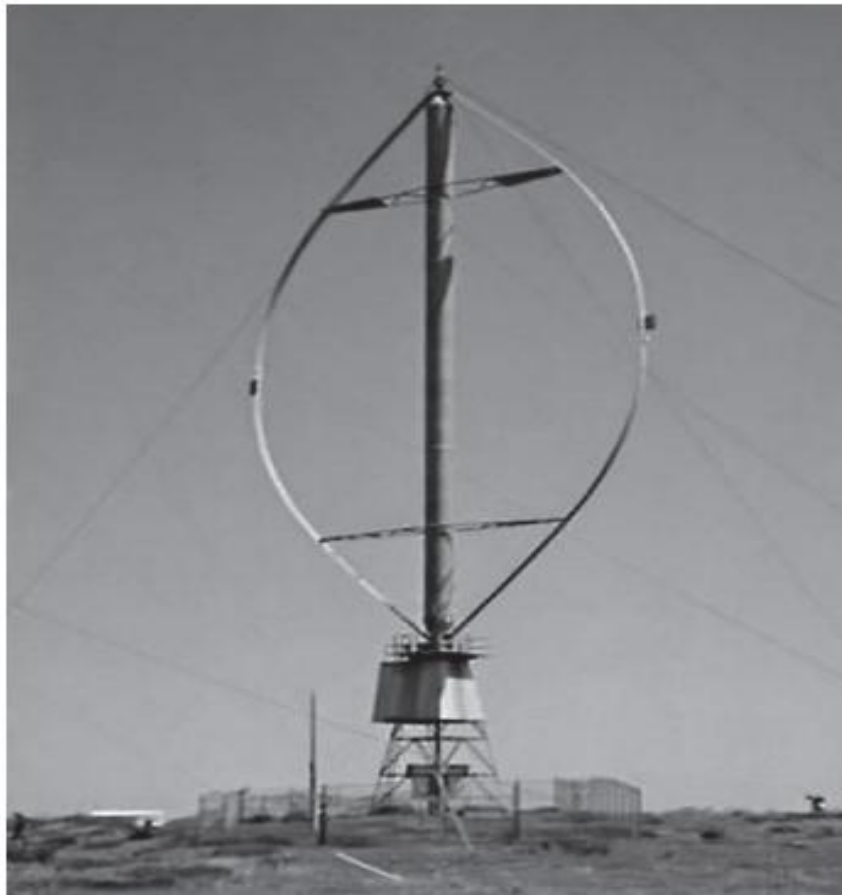

Figure (2.9) show a Darrius turbine. [1]

2.6.2.3 Savories rotor:

A Savories turbine is a drag-type turbine, named after its inventor, Segued J Savories. Cylinder sections fixed to a shaft in the form that their cross section makes a letter “S,” At each moment in time one blade captures the wind while the other moves against the wind, thus opposing the wind. The net torque to

rotate the turbine is the torque from the blade capturing the wind energy minus the resistive torque that the other blade receives against moving. This is the case for all the drag-type turbines one can add more half cylinders on the shaft in order to increase the Capacity of wind capture. This is equivalent to increasing the length of the cylindrical sections, if all the sections are aligned. Alternatively a second set can be installed at 90° from the first half cylinders. This adds to the uniformity of rotational torque on the shaft, since with only two half cylinders the absorbed power pulsates (this is not uniform as the rotor turns). [4]

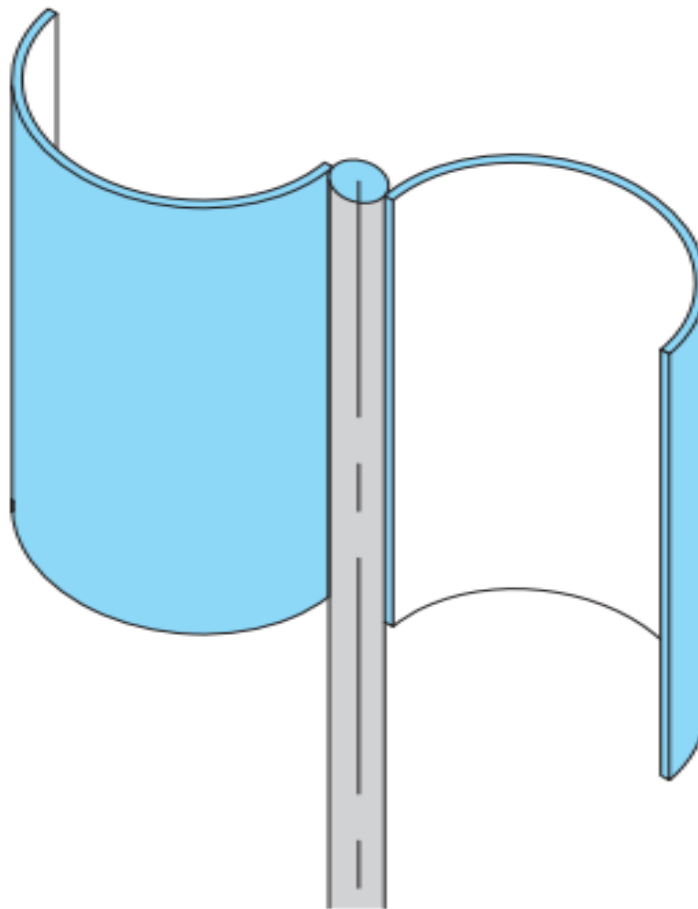

Figure (2.10) show the Construction of a simple Savories rotor. [4]

2.7 Three – Blade Propeller –Type Wind Turbine and Its

Components:

We learned that there are various types of wind turbines. However, the efficiency and practicality of horizontal axis, three-blade Propeller-type turbines has resulted in domination of the market and, in almost all the new installations of wind farms, this is the only type that is employed for energy generation. A wind turbine must grasp the mechanical energy from wind and convert it to electrical energy, so it has both mechanical components and electrical components in this paragraph we discussed some of these components. Both categories then can be divided into primary components (those without which a turbine cannot function) and the secondary components that either are much smaller, or could be deleted based on the design of each particular turbine. [1]

Table (2.2) show the wind turbine component [1]

Wind turbine major component		
Mechanical	primary	Tower, nacelle, rotor, foundation
	secondary	Gearbox, brake
Electrical	primary	Generator, transformer
	Secondary	Anemometer, vane, rectifier, inverter

2.7.1 Mechanical components:

A wind turbine primarily consists of a tower, a nacelle, a rotor (a hub and three blades), and a foundation, which cannot be seen. The blades are connected to a central hub, which rotates with them. The whole assembly is called a rotor. The rotor is mechanically isolated from the rest of the turbine that does not rotate with wind. The blades and hub rotate the main shaft, which goes inside an enclosed space on the top of the tower. This enclosed space is called the nacelle The nacelle houses

the gearbox, generator, and all the other necessary components such as heat exchangers, coolers and heaters, other motors and gears.

2.7.1.1 Tower:

The tower supports the other parts and holds them in the air (off the ground) thus the tower must be structurally strong to withstand the weights of the Components it supports and the forces from wind that can easily bend or break The tower if it is not strong enough. In the earlier turbines lattice towers were used. The Up of a number of metallic bars that are bolted or welded se towers are like the ones used for overhead transmission lines, made together. These towers.

Can have various designs based on the height. These towers are usually made in a number of shorter segments that make both manufacturing and transportation easier. The segments are attached together by bolts. Each segment is lifted by a crane and bolted to the segment below it. Each tower segment can be (18–21 m) long. Each tower segment has a platform at its bottom. This makes it easier for climbing and descending, since each segment is isolated from others, as well as the fact that a person can rest in the middle, before continuing farther up or down.

The other type of tower wind turbine is tubular towers, these are made up of rolled steel in the form of a cylinder or sometimes slightly tapered in the form of a conic section, and the diameter of a tubular tower can be (3–4 m). If it is tapered, it has a smaller diameter on the top. Some towers can be made of a concrete lower segment and the upper segments are metallic (steel). All tubular towers have an entrance door at the bottom. From the safety point of view, this door must be kept locked and only authorized people can have access.



Figure (2.11) show Turbines with lattice tower.

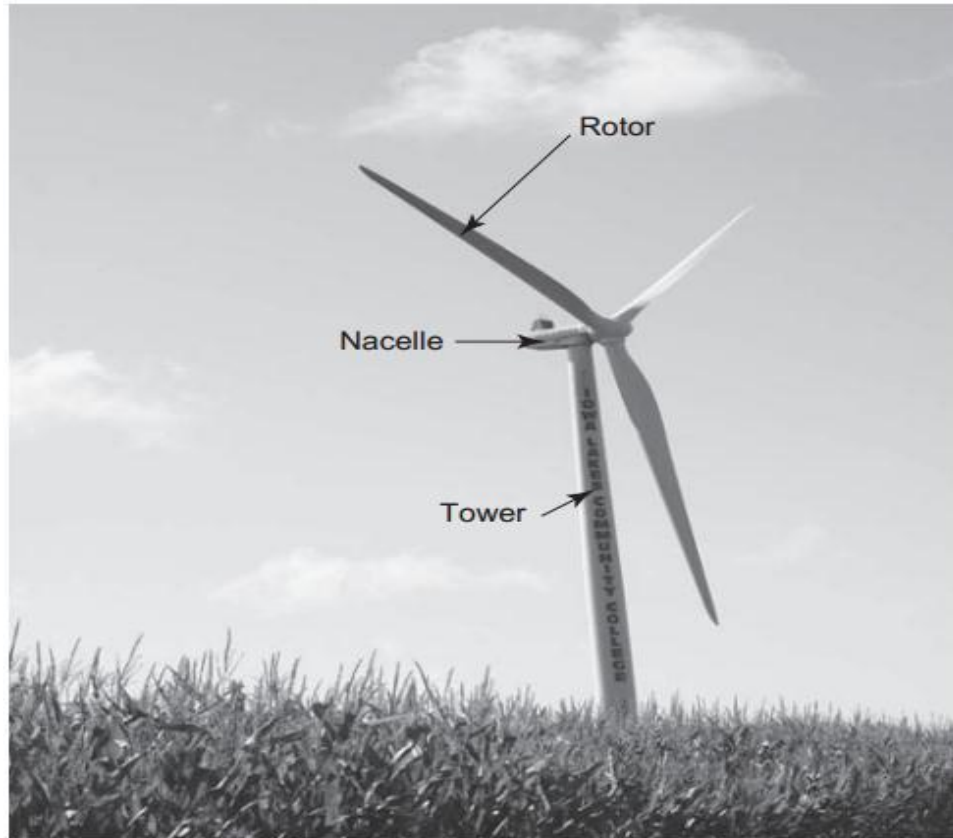

Figure (2.12) show typical modern wind turbine with tubular tower

The tubular towers have a number of advantages over the lattice towers among them are:-

- Tubular towers make an enclosed space, which can be more protective for electric and communication cables and other components, such as a Winch for lifting equipment, against weather conditions (snow, ice, cold Dust, sunshine, etc.).
- They are more protective for people climbing the turbine for maintenance and other purposes against wind, cold, rain, snow, and so on.
- Birds are not tempted to make their nests on the tower elements, as frequently Seen with the lattice towers.
- They have a nicer look.

2.7.1.2 Foundation:

Any turbine tower must be able to withstand all the various forces from the wind. A turbine is like a high-rise building, which is subject to heavy weight and large lateral forces from wind. For any heavy structure, the foundation must be strong enough to withstand the forces. Because soil is not strong, the foundations of large structures are mounted on a number of piles that are inserted in the ground by hammering action.

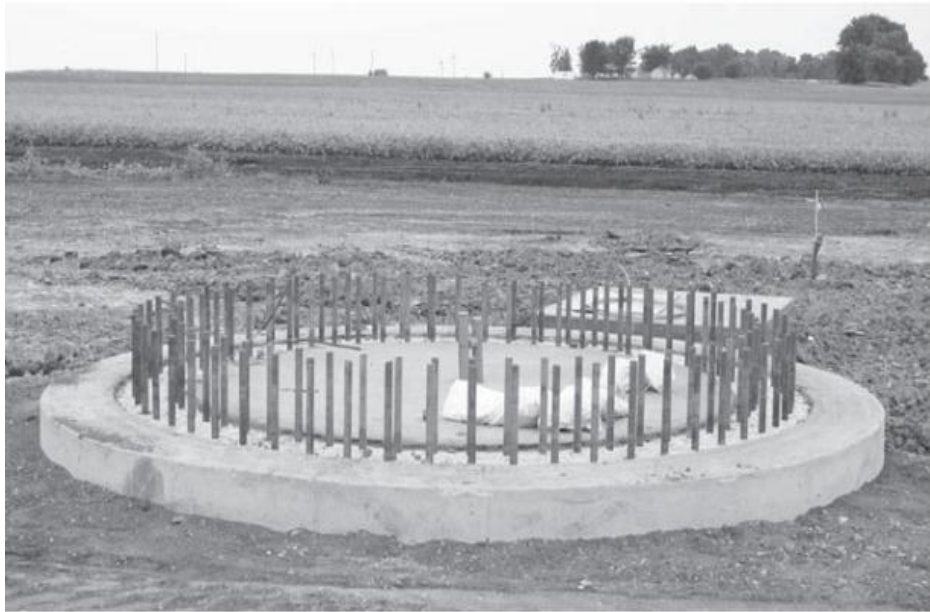

Figure (2.13) show a finished foundation before installing the tower

2.7.1.3 Rotor (blades and hub):

Rotor refers to all the rotating parts of a turbine. Blades are the parts of a wind turbine that catch the wind energy. Blades have the form of an airfoil. Whereas the profile of the airfoil may be the same, the size of the airfoil is not the same along the length of each blade. This is partly because of the aerodynamic property that the tip of a blade must become smaller and be rounded, and partly because of the mechanical strength that the root of a blade must be stronger, thus larger and thicker, than the other parts.[1]



Figure (2.14) show the hub and part of a nacelle

2.7.1.4 Nacelle:

The nacelle part intermediate between the rotor and the tower, the nacelle does not rotate with the rotor, but it must rotate with respect

To the tower. This rotating motion, called yaw, is necessary for directing the turbine to the wind stream, as the direction of wind is not fixed. This motion is provided by the yaw system, which comprises a number of yaw motors and a yaw gear.

The output shaft from the rotating rotor goes inside the nacelle. The Shaft transfers the mechanical energy to a generator, to be converted to electrical energy. In most of today's turbines this transfer is not direct and there is a gearbox between the main shaft (rotor output) and the high-speed shaft (the generator input). Thus, various equipment's are housed inside the nacelle.

The nacelle is a compartment not fixed to the tower and not fixed to the hub. "Not fixed" here implies that there are bearings between the two that allow

them to move with respect to each other; that is, the assembly of hub and blades rotate with respect to the nacelle, and the nacelle rotates about the tower axis. The nacelle serves the following purposes:

1. Houses the gearbox, generator, coolers for the gearbox oil, and heaters for winter time, turbine brake system, motors and gear for yaw system, the wind direction and speed measurement systems, the transformer for turbine energy supply.
2. Allows yawing of the turbine; that is, adjusting the turbine orientation to the wind direction.
3. Provides counterweight for the hub and blades' weight.



Figure (2.15) show the nacelle and hub

2.7.1.5 Gearbox:

Gears are used when the rotational speed of a “driving element” is different from the rotational speed of a “driven element.” In most cases, the speed of the driving element, which can be an electric motor, an engine, a gas turbine, a steam turbine, and so on, is higher than the speed of the part that must be driven. When one or more sets of gears are used for this purpose, all the gears are placed in an enclosed compartment, which also facilitates the lubrication and removal of the generated heat. The assembly of gears and the housing is called the gearbox.

In a wind turbine, the rotational speed of the rotor must be matched To that of the generator. This is achieved through the turbine gearbox. Wind turbines are among the exceptional cases that the rotational speed of the driving element (here, the rotor) is smaller than the speed of the generator. A gearbox, thus, must increase the rotor speed to become appropriate for the generator. The typical speeds for most generators are between 900 to 1800 rpm, whereas today’s wind turbines have a speed in the range of 12 to 24 rpm. A wind turbine gearbox, then, must increase the speed by a ratio of around 75 ($1800 / 24 = 75$). A conversion ratio of 75 is rather high and from the design viewpoint cannot be done by only one set of gears. [1]

2.7.1.6 Turbine brake:

Any turbine needs to be stopped on various occasions, such as for maintenance work, strong winds, a malfunction of some components, and so on.

It is necessary, therefore, that each turbine be equipped with a mechanical braking system that prevents the rotor from turning. When a turbine is in the shut-down condition.

Wind turbines are usually equipped with a proper brake similar to an Automobile disk brake that would be applied when not working. This brake System is usually mounted on the high-speed shaft (before the generator). In addition to this, for the maintenance work, or when a turbine must be stopped for a long time, the rotor can be locked in a position by inserting a pin inside a hole in a disk attached to the main shaft. In this way, the rotor is locked to the body of the nacelle and cannot move. A wind turbine brake is illustrated in Figure below.[1]

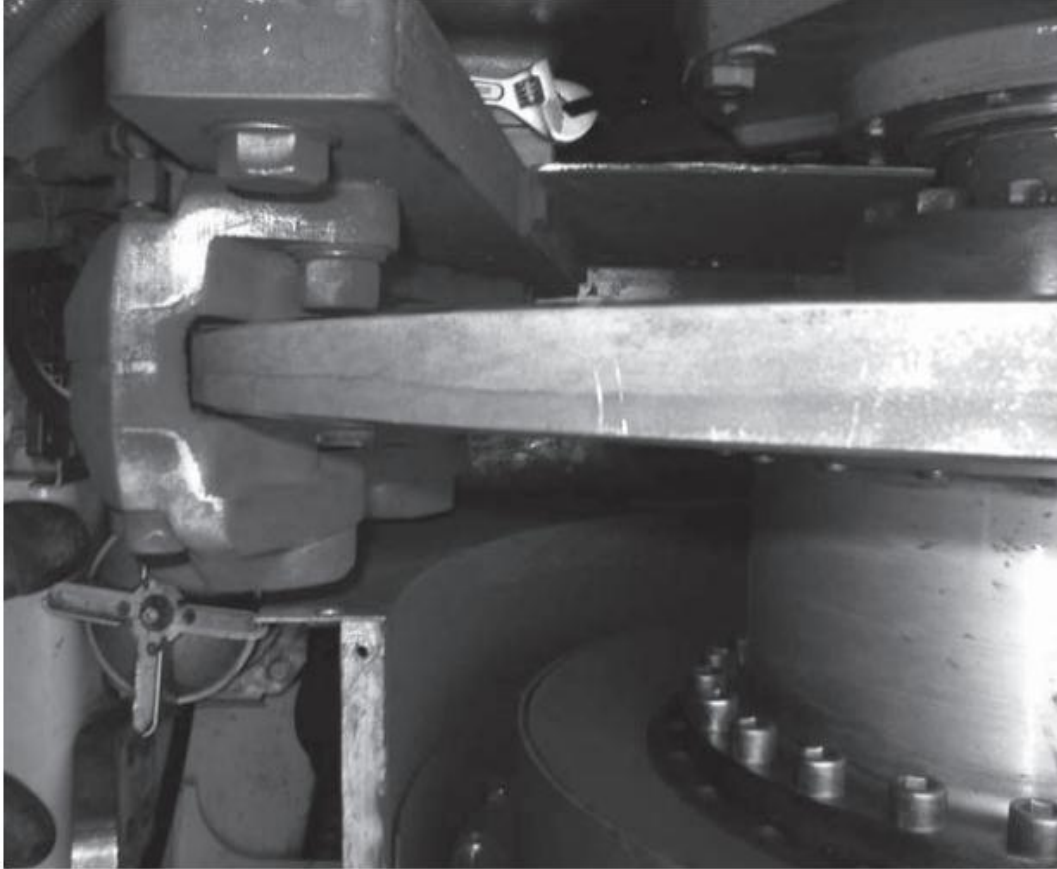

Figure (2.16) show a typical wind turbine brake

2.7.2 Electrical components:

The major electrical components of a wind turbine are the generator and the transformer. There are many other electrical components for various functions, such as motors for yaw motion, motors for blade pitch motion, motors for oil circulation pumps, space heaters for winter time warming inside the nacelle, lighting, and so on. [1]

2.7.2 1 Generators:

An electric generator, converts mechanical energy to electrical energy. It comes in different sizes, The size is proportional to power a generator, in fact, has the same construction as a motor, A generator can produce DC (direct current) electricity, or AC (alternating current) electricity. This depends on the design of the machine. [5]

2.7.2.2 Transformers:

An electrical device to increase or decrease the voltage in AC electricity. In the simplest form it has one primary winding where the supply electricity is connected, and one secondary winding where the output is taken.

If a transformer increases the voltage, it is called a step-up transformer; if it decreases the voltage it is called a step-down transformer. [5]

2.8 Propeller wind turbine blades and the wind force:

It is interesting to know how wind turns a propeller wind turbine, while blowing toward it. This is the opposite of what happens with an electric fan. In an electric fan, the blades rotate and as a result air is pushed ahead. In a wind turbine, the flow of the air forces the blades to rotate.

The tip of a blade is the side farther from the turbine shaft, and the root of a blade is the side near the shaft, a blade is not flat but is twisted between its root and its tip Also, a blade is narrower at the tip than at the root.

Figure (2.17) a shows a schematic of a typical blade of a wind turbine. A blade of a wind turbine can be divided into different segments, each one, say, 1 m wide, as shown in figure (2.18a) The effect of the wind on each segment is a force, pushing the segment back as well as lifting it. We refer to these forces as force components, since in combination they represent the force from wind on each segment. The sum of all the force components pushing the segments results in pushing and bending a blade. The sum of all the forces lifting the segments causes the rotation of the blade. This is shown in Figure (2.18b).As we can see from figure (2.18a), the effect of each segment on the blade rotation also depends on how far the segment is from the shaft axis. So, the segments that are near the blade tip have a greater share in blade rotation and the segments near the root have a lesser contribution. Note that the drag and lift forces are shown in the figure when the blades are rotating, not when they are stationary.



Figure (2.17) a typical blade of a modern wind turbine.

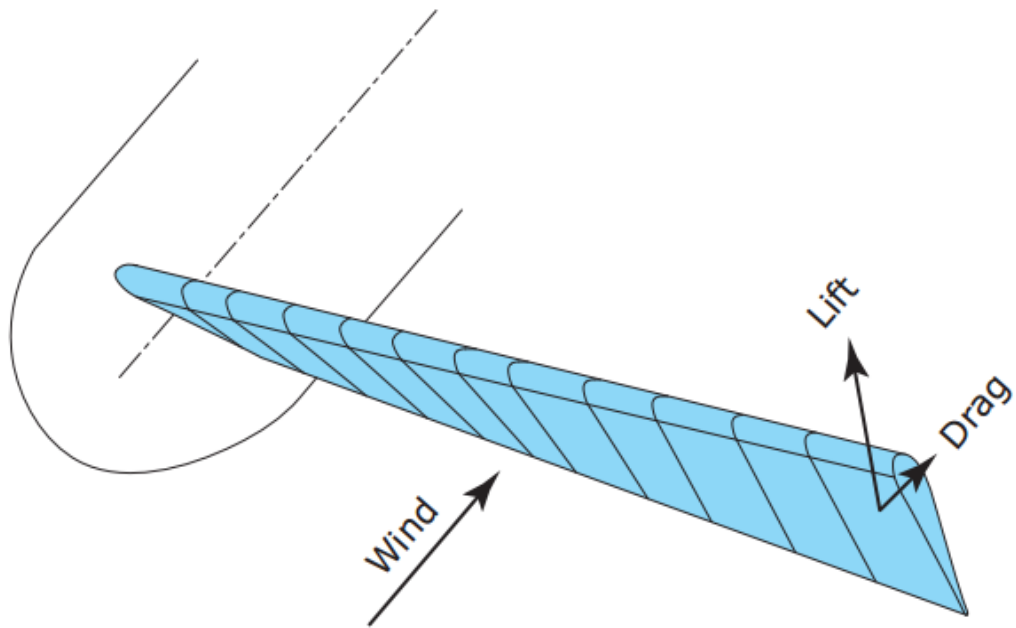

Figure (2.18a) show analysis a blade can be divided into a number of segments

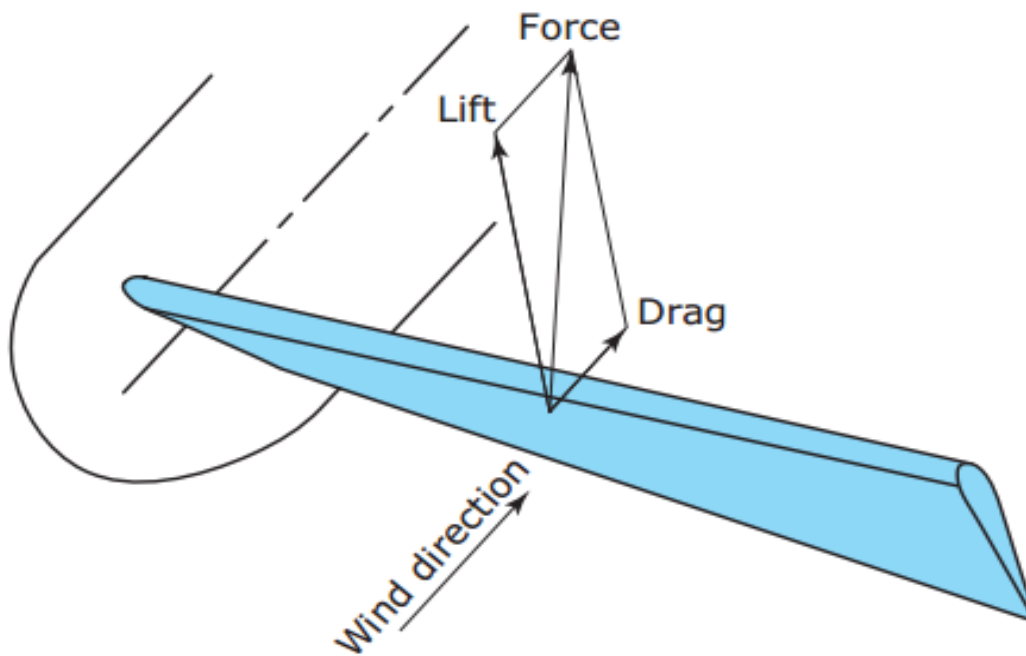

Figure (2.18b) show Force from the wind on a blade can lead to a Drag component and a lift component

2.9 SPEED OF A POINT ON A ROTATING OBJECT:

In all machinery, when a part is attached to a shaft and rotates with it, the Shaft and all that rotate with it have a common “angular speed.” However, various points on a rotating part do not have the same “linear speed.” The linear speed for each point depends on the angular speed and the distance from the shaft axis (the axis of rotation). This is shown below

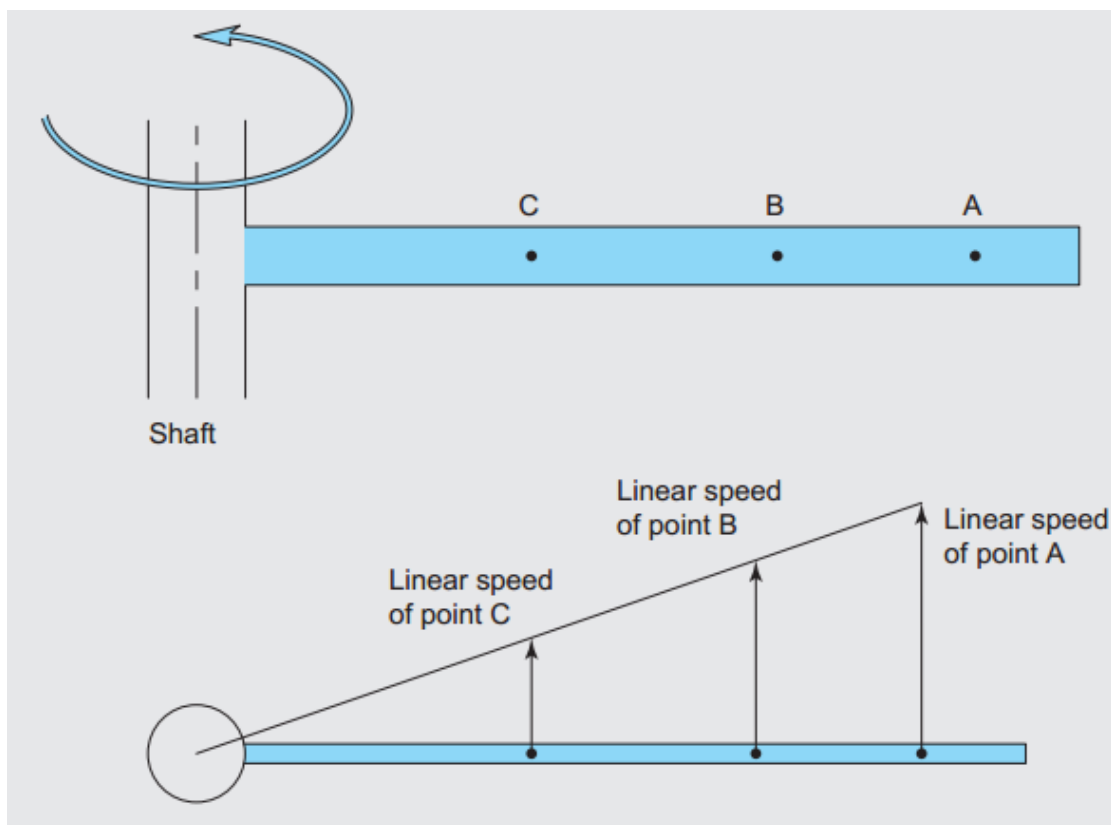

Figure (2.19) explain the variation of linear speed in blade

2.10 Aerodynamic force:

The force from wind on a plate is called aerodynamic force, Air flow over a stationary airfoil produces two forces, a lift force perpendicular to the air flow and a drag force in the direction of air flow, as shown in Figure (2.20).

We referred to the two aerodynamic force components as lift and drag. In fact, and any force can be broken into two components. Here the lift force and the drag force are the two components of the aerodynamic force on the plate under consideration. These two components are perpendicular to each other; that is, they make an angle of 90° with each other, as shown in figure (2.21)

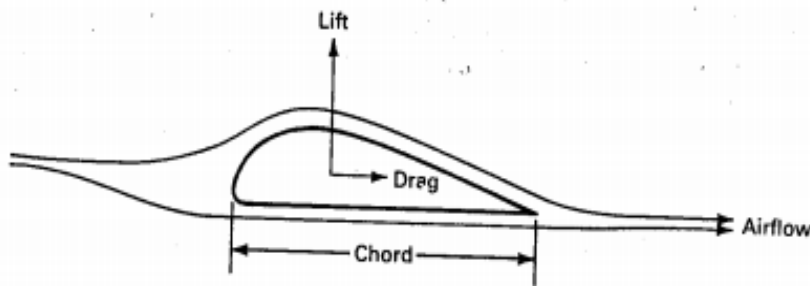

Figure (2.20) show Lift and drag on a stationary airfoil

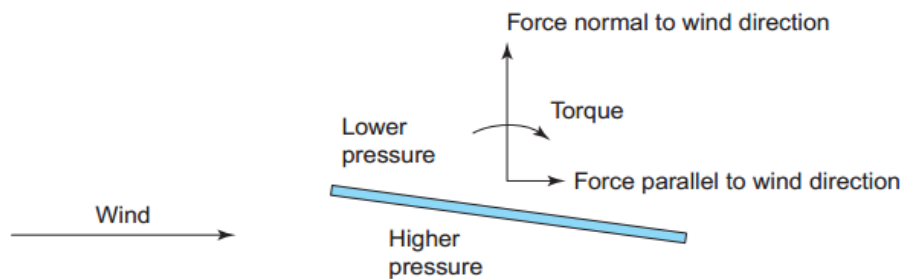

FIGURE (2.21) Force and torque from wind on a plate

2.11 Lift and drag coefficients:

In the previous sections we are learned about aerodynamic force, lift and drag, which are the two components of aerodynamic force on an object in the path of wind. And also learned that the values of lift and drag are not constant and can change depending of lift coefficient and drag coefficient, the magnitudes of the lift and drag forces depend on the angle of attack.

2.12 Airfoils:

A profile for the outline of an airplane wings or a turbine blades with the property of having a large lift coefficient and a very small drag coefficient.

The importance of drag and lift forces is their contribution to the active action in the operation of a wind turbine, in a wind turbine we like to have the maximum power drawn from wind at each wind speed. For this reason, if the turbine works based on lift force, we like the lift force to be much larger than the drag force. If, on the other hand, a turbine works based on the drag force, we like the drag force to be larger than the lift.

It may be worth mentioning here that airplanes work based on the lift force on their wings. When an airplane moves, it behaves as if it is stationary and air flows around it, like an object in the wind stream. In the case of an airplane, the drag force is opposite to the airplane motion and it is not desirable; thus, its value must be as small as possible. On the contrary, lift is the force that keeps the plane in the air; so, it is desirable that its magnitude is large.

In order we employed an airfoil instead of a flat plate to increase the lift and reduce the drag, this is true for an airplanes wings as well as for the blades of the majority of the wind turbines. An airfoil has a cross section as shown in figure (2.22)

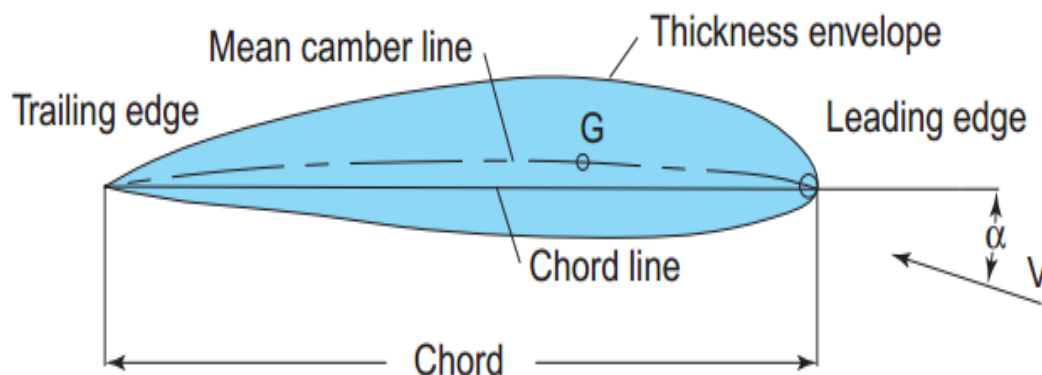

Figure (2.22) show typical pattern of an airfoil and the definition of its various terms

There is not only one airfoil, but many designs exist that are different from each other and have different characteristics it is quite important to note that many different sizes of airfoils can be made From one airfoil profile. In other words, if the relative sizes of various parts of an airfoil are kept the same we can have many different scales of the same airfoil.

For all the different sizes, the lift and drag coefficients will be the same, but the lift and drag forces will increase with the area of the airfoil. If the area doubles, so does the aerodynamic force; and, thus, the lift and drag forces double.

2.13 Blade twist:

The difference between airplane wing and a propeller turbine blade, the airplane wing is flat relative to a wind turbine blade, which has a twist that is, the Tip of a blade is not parallel to the blade root. This twist is not much, and can be only a few degrees, depending on the blade length, the reason why a blade must be twisted by an angle and not flat can be seen from the fact that in order to have a good lift force on a blade the air flow must hit the blade at a proper angle. This is the angle of attack. And when a blade rotates, the points at the tip side go faster than the points near the root. Since the wind speed is approximately the same for all the points on a blade

