

**Sudan University of Sciences & Technology**



**College of Engineering**



**School of Electrical & Nuclear Engineering**

**Auto-Restart Circuit for Variable Speed Drive  
by Using Smart Relay in Petroleum Wellheads**

**دائرة إعادة التشغيل لسواقة مغير السرعة باستخدام المرحل الذكي في**

**ابار البترول**

**A Project Submitted In partial Fulfillment for the Requirements of the  
Degree of B.Sc.(Honor) In Electrical Engineering**

**Prepared By :**

- 1- Abdullahi Mohammed Ali Khalid**
- 2- Amjed Ibrahim Osman Elhussain**
- 3- Eltayeb Hamdoon Eltayeb Hamdoon**
- 4- Mutasim Gadallah Ahmed Sharaf Eldin**

**Supervised By :**

**Ust. Galal Abdulrahman Mohammed**

**October 2015**

## الآية

بسم الله الرحمن الرحيم

: ﴿ وَأَنْزَلَ اللَّهُ عَلَيْكَ الْكِتَابَ وَالْحِكْمَةَ وَعَلَّمَكَ مَا لَمْ تَكُن تَعْلَمُ ﴾ .

صدق الله العظيم

" النساء 113 "

# **DEDICATION**

We dedicate this project to our parents, the Source of kindness father and mother thank you in believing in us for your unconditional support with our studies. We are honored to have you as our parent's thank you for giving us a chance to prove and improve our self through all our walks of life please do not ever change, we love you.

## **ACKNOWLEDEMENT**

Our prophet Mohammed –peace be upon him- endears knowledge and the people who tries hard to deliver it as in hadith Abu Hurairah : {Allah makes the way to Jinnah easy for him who treads the path in search of knowledge.} [Muslim]. After thanking God for giving us the courage and the determination, as well as giudness in conducting this project, despite all the difficulties we faced. We also would like to express our gratitude to Ust. Galal Abdulrahman Mohammed for supervising this project and giving us the support we needed. Great thanking to Sudan University Of Science and Technology and the School of Electrical and Nuclear Engineering for their efforts in teaching us and giving us such an opportunity to finding our way throw this project and made it too easy to search and finding the useful information which it was so helpful to complete this project, we also thank the Turkish Sudanese Institute for their help in the programming and designing the project module, and special thanking to Eng. Osam Hussain Al-khaleefah and Eng. Mohannad Alsaied for their great help in the project.

# **ABSTRACT**

Auto Restart Circuit solved the sudden start of the motor which cause the breakage of the shaft which connect the motor to the pump due the reversal rotation of the shaft, and will also solve the time loss caused by the operator (if we consider that there was an operator who operate and perform the restart of the pump) because the wellhead is far away from central process facility.

Here comes the smart relay part to solve the above problems we need to set the smart relay to start the pump after specific time ( when reverse rotation stop ) , so by connecting smart relay with the Variable Speed Drive (VSD) to perform the auto restart operation we will cause a reduction in the errors.

## مستخلص

دائرة إعادة التشغيل حلت مشكلة التشغيل المفاجئ للموتور والذي يسبب كسر في عمود الدوران المرتبط وأيضاً حلت مشكلة التأخير الزمني الناتج عن عامل التشغيل (إذا أخذنا بالإعتبار ان هنالك عامل تشغيل يقوم بعملية إعادة تشغيل الطرمبة ) لأن بئر النفط يمسافة بعيدة عن منشأة المعالجة المركزية.

هنا يأتي دور المرحل الذكي لحل المشكلات السابقة حيث يتم ضبط المرحل الذكي لتشغيل طرمبة النفط بعد فترة زمنية محددة ( بعد إنتهاء الدوران العكسي لعمود الدوران) مغير سرعة المحرك تقوم بعمل دائرة إعادة التشغيل وبذلك يتم تقليل الأخطاء .

# TABLE OF CONTENTS

Content	Page
الآية	i
DEDICATION	ii
ACKNOWLEDEMENT	iii
ABSTRACT	iv
	v
TABLE OF CONTENTS	vi
TABLE OF FIGURES	ix
LIST OF ABBREVIATIONS	xi
<b>CHAPTER ONE</b>	
<b>INTRODUCTION</b>	
1.1 Entrance	1
1.2 Problems Statements	2
1.3 Objectives	2
1.4 Methodology	2
1.5 Layout	3
<b>CHAPTER TWO</b>	
<b>THEORETICAL BACKGROUND</b>	
2.1 Petroleum	4
2.2 Locating the Oil Field	5
2.3 Facilities and Processes	6
2.3.1 Exploration	6
2.3.2 Upstream	6
2.3.3 Midstream	6
2.3.4 Refining	6
2.3.5 Petrochemical	7
2.4 Onshore	7
2.5 Offshore	8
2.6 Upstream Process Sections	8
2.7 Manifolds and Gathering	8
2.8 Separation	9
2.9 Metering & Storage And Export	10
2.10 Utility Systems	10

2.11 Midstream	11
2.12 Exploration and Drilling	11
2.12.1 Exploration activities	11
2.12.2 Exploration methods	12
2.13 Site Preparation and Well Construction	12
2.14 Rotary Drilling	13
2.14.1 The rotary drilling contents	14
2.15 Rotating Equipment	15
2.15.1 Drill bit	16
2.15.2 Blowout prevention	16
2.16 Drilling Techniques	17
2.17 The well	18
2.17.1 Well casing	18
2.17.2 Types of casing	19
2.17.3 Wellheads	20
2.17.4 Wellheads equipments	21
2.18 Artificial Lifts	22
2.18.1 Rod pumps	22
2.18.2 Downhole pumps	23
2.18.3 Types of downhole pumps	24
2.18.4 Progressing cavity pumps principle	27
2.19 Smart Relay	27
2.19.1 Types of relays	28
2.20 Programmable Logic Controllers (PLC)	29
2.20.1 Micro PLCs (Smart Relay)	31
2.20.2 Smart relay interface	31
2.21 Variable Speed Drive (VSD)	32
2.21.1 Types of control in Variable Speed Drive	33
2.21.2 Component of Variable Speed Drive	35
2.22 Variable Speed Drive Operation	36
<b>CHAPTER THREE</b>	
<b>THE CIRCUIT</b>	
3.1 Real circuit	38
3.2 Simulation circuit	38
3.3 Variable Speed Drive (VSD)	39
3.4 Smart Relay	39
3.5 Alternating Current (AC) Motor	40
3.6 Microcontroller	41
3.7 Voltage Regulator	42



3.8 Universal Linear Driver (ULN 2802A)	43
3.9 Liquid Crystal Display (LCD)	43
3.10 Inferred (IR) led Transmitter and Receiver	45
3.10.1 IR transmitter	45
3.10.2 IR Receivers	45
3.11 Switches	46
3.12 Resistors	47
3.13 Capacitors	47
3.14 Direct Current (DC) Motor	48
<b>CHAPTER FOURE</b>	
<b>CIRCUIT OPERATION</b>	
4.1 Real circuit	50
4.2 Simulation circuit	50
<b>CHAPTER FIVE</b>	
<b>Conclusion and Recommendations</b>	
5.1 Conclusion	54
5.2 Recommendations	54
<b>REFFRENCES</b>	
<b>APPENDIX A</b>	
<b>APPENDIX B</b>	
	62

## TABLE OF FIGURES

<b>Figure</b>	<b>Name</b>	<b>Page</b>
2.1	Processor of separation	9
2.2	Migration of oil and gas sedimentary basin	11
2.3	Collar and conductor casing	13
2.4	Rotary drilling rig	14
2.5	Hoisting equipment	15
2.6	Rotating equipment	15
2.7	Drill string schematic	15
2.8	Polycrystalline diamond compact drill bit	16
2.9	Blowout preventer	17
2.10	Deviated well	18
2.11	Extended reach well	18
2.12	Horizontal drain well	18
2.13	Typical casing program showing different casing sizes and their sitting depths	20
2.14	Wellhead construction	22
2.15	Christmas tree	22
2.16	Sucker (rod) pump	23
2.17	Downhole pump	23
2.18	Schematic of typical ESP pump system	25
2.19	Progressing cavity pumps	27
2.20	Sample diagram of work principle of the relay	28
2.21	PLC product range	30
2.22	PLC block diagram	30
2.23	Block diagram of major CPU components	31
2.24	Smart relay	32
2.25	Internal structure for the VSD	35
2.26	VSD basic existing technology	36
3.1	Shows the variable speed drive	39
3.2	Shows the smart relay	40

3.3	Microcontroller atmega 16	42
3.4	Regulator L78XX	43
3.5	ULN 2802A circuit	43
3.6	Liquid crystal display	44
3.7.1	IR transmitter	45
3.7.2	IR receiver	45
3.8	The frequency range and wavelengths	46
3.9	Part of multi-polar DC motor	48
3.10	The motor principle	49
3.11	The simulation circuit block diagram	49
4.1	Shows the main VSD circuit connection	52
4.2	Circuit connection	52

## TABLE OF ABBREVIATIONS

Abbreviations	Meaning of the Abbreviations
AC	Alternating Current
ADC	Analog to Digital Converter
API	American Petroleum Institute
ASD	Adjustable Speed Drive
B/D	Barrels Per Day
BOP	Blow Out Preventer
CMOS	Complementary Metal–Oxide–Semiconductor
CPU	Central Processing Unit
CRT	Cathode Ray Tube
DC	Direct Current
DIP	Dual Inline Package
DSU	Drilling Spacing Unit
E	Enable
E&P	Exploration and Production
EEPROM	Electrically Erasable Programmable Read-Only Memory
ER	Energy Rotation
ESL	Electrical Submerged pump
F	Fahrenheit
ft	Feet
GAL	Gallon
GND	Ground

GOR	Gas Oil Ratio
GOSP	Gas Oil SEPARATION Plant
HV-AC	High Voltage Accelerated Current
I/O	Input/output
IGBT	Insulated Gate Bipolar Transistor
in	Inch
IR	Infrared
KM	Kilo Meter
KV	Kilo Volt
KVA	Kilo Volt Ampere
KW	Kilo Watt
LCD	Liquid Crystal Display
LED	Light Emitting Diode
LNG	Liquid Natural Gas
MIPS	1 Million Instructions Per Second
MPA	Mega Pascal
NPN	Negative-Positive-Negative
PA	Port A
PB	Port B
PC	Port C
PCP	Progressive Cavity Pump
PD	Port D
PLC	Programmable Logic Controller
POC	Pump Of Controller
PSI	Petroleum Solution Incorporation
PWM	Pulse Width Modulation

R/W	Read /Write
RAM	Random Access Memory
RISC	Reduced Instruction Set Computer
RPM	Revolution Per Minuit
RS	Reset
RTU	Remote Terminal Unit
SCR	Silicon Controlled Rectifier
SPI	Serial Peripheral Interface
ULN	Universal Linear Driver
USA	United State Of America
$V_{cc}$ , $V_{dd}$	Input Voltages
VFD	Variable Frequency Drive
VSD	Variable Speed Drive
VVVF	Variable Voltage Variable Frequency

# CHAPTER ONE

## INTRODUCTION

### 1.1 Entrance

As we know the oil one of the most important raw materials we have every day, we use hundreds of equipments or tools that requiring oil or gas or it may be even made of it. Crude oil is the most important natural resource of the industrialized nations. It can generate heat, drive machinery and fuel vehicles and airplanes. Its components are used to manufacture almost all chemical products, such as plastics, detergents, paints, and even medicines. As it is such an important resource it is very important to expand our technical ability to discover new sources and extend the production lives of existing oil fields. Oil and gas are also important for the number of jobs that it provided it, tens of thousands of people work in the oil and gas industry .The oil industry is very important industry in the world and a lot of peoples depends on the price of the oil and it has been observed that whenever the oil price increased the price of various products also increases. According to the statistics the amount of oil that consumed by the whole world every year is as many as 30 billion barrel among which nearly 25 percent of the oil consumption is done by united states of America . So the oil and gas become one of the most important things in the life of human beings. <sup>[1]</sup>

That why we select our project from oil and gas industry to share and solve one of the problem which faces the product of the petroleum .Our project is about control start ,stop operation in the Variable Speed Drive (VSD) by using smart relay.

## **1.2 Problems Statements**

In the past we used to control VSD manually specially the start-stop operation and of course this old school method has many disadvantages.

When blackout happened we need the operator to start the pump, also blackouts causing obstruction in the pump but as we know in petroleum fields the pump will start reversing because the crudes is heavy so we will need to wait till the rotation stop to perform the start operation, also when the blackouts happens at night this will be so difficult for the operator to go there and restart the pump All the previous introduction is all about protecting the pump's shaft which will breaks if the pump started suddenly. Also it will increase the safety of the operator when blackout happens.

## **1.3 Objectives**

This project has several objectives represented in:

- ❖ Automate the restart operation on variable speed drive (VSD) by using smart relay.
- ❖ Provide a protection for the operator and for the sensitive well equipments.
- ❖ By using the auto restart circuit the cost had been reduced.

## **1.4 Methodology**

When blackout happen the motor stop, then the shaft reverse the rotation. Here the auto restart circuit will start counting the time of reverse rotation and then after specific time the motor will stop, we programmed the smart relay timer to perform auto restart operation to motor, the timer adjusted by calculation depends on the depth of the well and density of the crude the time Variable speed drive provides soft start to the motor which protect the shaft from breakage.



## **1.5 Layout**

The first chapter contained an introduction about our project and it consists of Entrance, Problems statements, Objectives and methodology. The second chapter contained a theoretical background and it consist of Petroleum in general, Locating of oil field, Facilities and processes such as Upstream , Midstream and Downstream, Onshore and offshore wellheads, Drilling Techniques, Pumps, Smart relay and Variable Speed Drive . The third chapter contained information about the circuit and it consist of information's and components of the Real circuit and the Simulation circuit. The fourth chapter contained the circuit operation of the Real circuit and the Simulation circuit. The fifth chapter contained the conclusion and recommendations. At last we attached needed appendix.

# CHAPTER TWO

## THEORETICAL BACKGROUND

### 2.1 Petroleum

Oil has been used for lighting purposes for many thousands of years. In areas where oil is found in shallow reservoirs, seeps of crude oil or gas may naturally develop, and some oil could simply be collected from seepage or tar ponds.

Historically, we know the tales of eternal fires where oil and gas seep signited and burned. One example is the site where the famous oracle of Delphi was built around 1,000 B.C. Written sources from 500 B.C. Describe how the Chinese used natural gas to boil water. It was not until 1859 that "Colonel" Edwin Drake drilled the first successful oil well, with the sole purpose of finding oil. The Drake Well was located in the middle of quiet farm country in northwestern Pennsylvania, and sparked the international search for an industrial use for petroleum. Oil had replaced most other fuels for motorized transport. The automobile industry developed at the end of the 19th century, and quickly adopted oil as fuel. Gasoline engines were essential for designing successful aircraft. Ships driven by oil could move up to twice as fast as their coal powered counterparts, a vital military advantage. Gas was burned off or left in the ground. With the appearance of automobiles and more advanced consumers, it was necessary to improve and standardize the marketable products. Refining was necessary to divide the crude infractions that could be blended to precise specifications. As value shifted from refining to upstream production, it became even more essential for refineries to increase high-value fuel yield from a variety of crudes. From 10-40% gasoline for crude a century ago, a modern refinery can get up to 70% gasoline from the same quality crude through a variety of advanced reforming and cracking processes.

Chemicals derived from petroleum or natural gas – petrochemicals – are an essential part of the chemical industry today. Petro chemistry is a fairly young industry; it only started to grow in the 1940s, more than 80 years after the drilling of the first commercial oil well. With increasing consumption and ever-increasing conventional and unconventional resources, the challenge becomes not one of availability, but of sustainable use of fossil fuels in the face of rising environmental impacts, that range from local pollution to global climate effects.<sup>[1]</sup>

Many theories have been advanced to explain the origin of hydrocarbons but the theory best supported by observation to date is that petroleum is organic in origin. Most petroleum hydrocarbons were formed in marine environments. Plant and animal matter falls continually to the ocean floor, where it is entombed in the forming sediments. Once air is excluded, decomposition ceases, and increasing temperature and pressure drive off the gases created by the action of anaerobic bacteria.

Very little petroleum forming activity takes place at temperatures less than about 150° F. As the petroleum hydrocarbons are formed, they tend to migrate upwards. This migration takes place continuously once the hydrocarbons have been generated, and they will take any path to the surface that is offered. They may migrate through permeable reservoir rocks. Often the vertical fractures created along stress lines in folded rocks allow hydrocarbons to rise through otherwise impermeable strata. The cracks and fissures resulting from faulting are another obvious path.

## **2.2 Locating the Oil Field**

Geologists use seismic surveys to search for geological structures that may form oil reservoirs. The classic method includes making an underground explosion nearby and observing the seismic response that provides information about the geological structures under the ground. Historically, in

the USA, some oil fields existed where the oil rose naturally to the surface, but most of these fields have long since been used up, except in certain places in Alaska. Often many wells (called multilateral wells) are drilled into the same reservoir, to ensure that the extraction rate will be economically viable. Also, some wells (secondary wells) may be used to pump water, steam, acids or various gas mixtures into the reservoir to raise or maintain the reservoir pressure, and so maintain an economic extraction rate.

## **2.3 Facilities and Processes**

The oil and gas industry facilities and systems are broadly defined, according to their use in the oil and gas industry production stream.

### **2.3.1 Exploration**

Includes prospecting, seismic and drilling activities that take place before the development of a field is finally decided.

### **2.3.2 Upstream**

Typically refers to all facilities for production and stabilization of oil and gas. The reservoir and drilling community often uses upstream for the wellhead, well, completion and reservoir only, and downstream of the wellhead as production or processing. Exploration and upstream Production together is referred to as E&P.

### **2.3.3 Midstream**

Broadly defined as gas treatment, Liquid Natural Gas (LNG) production and re gasification plants, and oil and gas pipeline systems.

### **2.3.4 Refining**

Where oil and condensates are processed into marketable products with defined specifications such as gasoline, diesel or feedstock for the petrochemical industry. Refinery off sites such as tank storage and is

attribution terminals are included in this segment, or may be part of a separate distributions operation.

### **2.3.5 Petrochemical**

These products are chemical products where the main feedstock is hydrocarbons. Examples are plastics, fertilizer and a wide range of industrial chemicals.<sup>[1]</sup>

## **2.4 Onshore**

Onshore production is economically viable from a few dozen barrels of oil a day and upward. Oil and gas is produced from several million wells worldwide. In particular, a gas gathering network can become very large, with production from thousands of wells, several hundred kilometers/miles apart, feeding through a gathering network into a processing plant. There are many other ways of extracting oil from a non free-flowing well. For the smallest reservoirs, oil is simply collected in a holding tank and picked up at regular intervals by tanker truck or railcar to be processed at a refinery.

Onshore wells in oil-rich areas are also high capacity wells producing thousands of barrels per day, connected to a 1,000,000 barrel or more per day Gas-Oil Separation Package (GOSP). Product is sent from the plant by pipeline or tankers. The production may come from many different license owners, so metering of individual well-streams into the gathering network are important tasks. Unconventional plays target very heavy crude and tar sands that became economically extractable with higher prices and new technology. Heavy crude may need heating and diluents to be extracted.

Tar sands have lost their volatile compounds and are strip-mined or can be extracted with steam. It must be further processed to separate bitumen from the sand. Since about 2007 drilling technology and fracturing of the reservoir have allowed shale gas and liquids to be produced in increasing volumes. This allows the US in particular to reduce dependence on hydrocarbon imports.

Canada China, Argentina, Russia, Mexico and Australia also rank among the top unconventional plays. These unconventional reserves may contain more 2-3 times the hydrocarbons found in conventional reservoirs. <sup>[1]</sup>

## **2.5 Offshore**

A whole range of different structures is used offshore, depending on size and water depth. In the last few years, we have seen pure sea bottom installations with multiphase piping to shore, and no offshore topside structure at all. Replacing outlying wellhead towers, deviation drilling is used to reach different parts of the reservoir from a few wellhead cluster locations. <sup>[1]</sup>

## **2.6 Upstream Process Sections**

The activities up to the producing wellhead (drilling, casing, completion, and wellhead) are often called pre-completion, while the production facility is post-completion. For conventional fields, they tend to be roughly the same in initial capital expenditure. <sup>[1]</sup>

## **2.7 Manifolds and Gathering**

Onshore, the individual well streams are brought into the main production facilities over a network of gathering pipelines and manifold systems. The purpose of these pipelines is to allow setup of production well sets so that for a given production level, the best reservoir utilization well flow composition (gas, oil water) , can be selected from the available wells.

For gas gathering systems, it is common to meter the individual gathering lines into the manifold as shown in this picture. For multiphase flows (combination of gas, oil and water), the high cost of multiphase flow meters often leads to the use of software flow rate estimators that use well test data to calculate actual flow. Offshore, the dry completion wells on the main field center feed directly into production manifolds, while outlying wellhead

towers and subsea installations feed via multiphase pipelines back to the production risers. Risers are a system that allows a pipeline to rise up to the topside structure. For floating structures, this involves a way to take up weight and movement. For heavy crude and in Arctic areas, diluents and heating may be needed to reduce viscosity and allow flow. [1]

## 2.8 Separation

Some wells have pure gas production which can be taken directly for gas treatment and/or compression. More often the well produces a combination of gas, oil and water, with various contaminants that must be separated and processed. The production separators come in many forms and designs, with the classic variant being the gravity separator. In gravity separation, the well flow is fed into a horizontal vessel. The retention period is typically five minutes, allowing gas to bubble out, water to settle at the bottom and oil to be taken out in the middle. The pressure is often reduced in several stages (high pressure separator, low pressure separator) to allow controlled separation of volatile components. A sudden pressure reduction might allow flash vaporization leading to instability and safety hazards. [1]

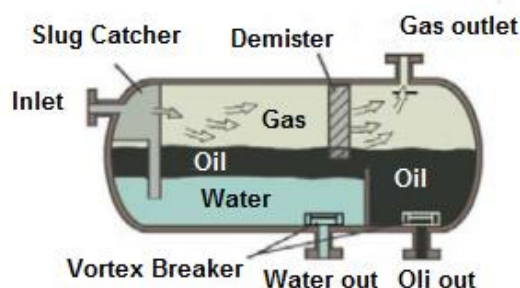

Figure 2.1: Processor of separation

## **2.9 Metering& Storage And Export**

Most plants do not allow local gas storage, but oil is often stored before loading on a vessel, such as shuttle tanker taking oil to a larger tanker terminal, or direct to a crude carrier. Offshore production facilities without a direct pipeline connection generally rely on crude storage in the base or hull, allowing a shuttle tanker to offload about once a week. A larger production complex generally has an associated tank farm terminal allowing the storage of different grades of crude to take up changes in demand, delays in transport. Metering stations allow operators to monitor and manage the natural gas and oil exported from the production installation. These employ specialized meters to measure the natural gas or oil as it flows through the pipeline without impeding its movement. This metered volume represents a transfer of ownership from a producer to a customer (or another division within the company), and is called custody transfer metering. It forms the basis for invoicing the sold product and also for production taxes and revenue sharing between partners. Accuracy requirements are often set by governmental authorities. Typically, a metering installation consists of a number of meter runs so that one meter will not have to handle the full capacity range, and associated prove loops so that the meter accuracy can be tested and calibrated at regular intervals.<sup>[1]</sup>

## **2.10 Utility Systems**

Utility systems are systems which do not handle the hydrocarbon process flow, but provide some service to the main process safety or residents. Depending on the location of the installation, many such functions may be available from nearby infrastructure, such as electricity. Many remote installations are fully self-sustaining and must generate their own power and water.<sup>[1]</sup>



## 2.11 Midstream

The midstream part of the value chain is often defined as gas plants, Liquid Natural Gas (LNG) production and regasification, and oil and gas pipeline transport systems. <sup>[1]</sup>

## 2.12 Exploration and Drilling

Firms engaged in oil and gas exploration and development face a daunting task. Drilling a single well on land can cost hundreds of thousands of dollars. Based on many decades of experience firms have identified in general terms those regions in which important oil-bearing formations may be found. In addition, they can use a variety of technical tools and procedures to pinpoint and analyze more accurately hydrocarbon deposits in a specific field.

### 2.12.1 Exploration activities

Once exploration rights have been established and related business issues negotiated, the technical work of finding and evaluating promising oil- and gas-bearing formations can begin. In decades past, companies would look for evidence of seepage at the surface, indicating the presence of hydrocarbons below the surface (figure 2.2). As noted by American petroleum institute (API), their tools were simple, their wells were shallow, and luck was a big part of the game. Today Exploration and Production (E&P) firms use a variety of advanced tools and techniques to gain a detailed picture of the subsurface. <sup>[2]</sup>

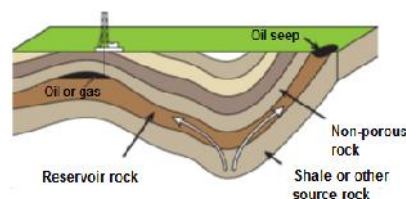

Figure 2.2: Migration of oil and gas in a sedimentary basin

### **2.12.2 Exploration methods**

Exploration geophysics is an applied branch of geophysics, which uses physical methods at the surface of the Earth to measure the physical properties of the subsurface, along with the anomalies in those properties. It is most often used to detect or infer the presence and position of economically useful geological deposits, such as ore minerals, fossil fuels and other hydrocarbons.

- ❖ Geologic methods.
- ❖ Geophysical methods.
- ❖ Survey methods.
- ❖ Gravimetric survey.
- ❖ Magnetic survey.
- ❖ Seismic survey.<sup>[2]</sup>

### **2.13 Site Preparation and Well Construction**

Typically, each onshore well is sited within a Drilling Spacing Unit (DSU) to prevent exploitation of a field with excessive drilling and production rates. More recently, based on advances in geologic evaluation and drilling technology, tighter spacing is being used, depending on such factors as formation permeability and heterogeneity, and drilling costs. Once the drilling site has been selected, several reparatory steps are taken. Workers establish the boundaries of the work area and carry out environmental impact studies if necessary. Lease agreements, titles, and right-of-way accesses also may be sought. After all legal and environmental issues are settled, the crew goes about preparing the drill site. For an onshore site, this entails the following steps:

- ❖ The land is cleared and leveled, and access roads are built if needed.
- ❖ Water well is drilled if necessary to provide the significant volumes of water used in oil and gas drilling operations.

- ❖ A reserve pit is dug and lined with plastic, to hold rock cuttings and drilling mud generated during the drilling process.
- ❖ In environmentally sensitive areas, the cuttings and mud are trucked off-site instead of being placed in the pit.

Once the land has been prepared, the crew digs several holes to make way for the rig and the main hole. A rectangular pit, called a cellar, is dug around the point where drilling will take place. The cellar provides a workspace around the hole and room for auxiliary equipment that will be located below the floor of the main drilling platform. The crew then drills the main hole, often with a small drill truck rather than the main rig. The first part of the hole is larger in diameter than, and not as deep as, the main portion will be and is lined with a large-diameter conductor pipe. Other holes are dug off to the side to temporarily store equipment. After these holes are finished, the rig equipment can be trucked in and set up. If necessary, equipment may be brought to the site by helicopter or barge. <sup>[2]</sup>

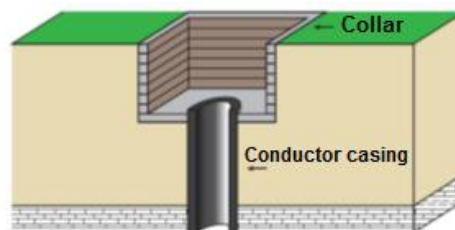

Figure 2.3: Collar and conductor casing

## 2.14 Rotary Drilling

Virtually all oil and gas wells onshore and offshore are drilled using a system called a rotary drilling rig, which can drill several hundred to several thousand feet per day. This system turns a long length of steel pipe with a sharp bit on its lower end to cut the wellbore. A basic rotary drilling system consists of four groups of components: prime mover (one or more engines), hoisting equipment, rotating equipment, and circulating equipment. Many innovations

have been developed since rotary drilling first came into widespread use in the early 1900s. [2]

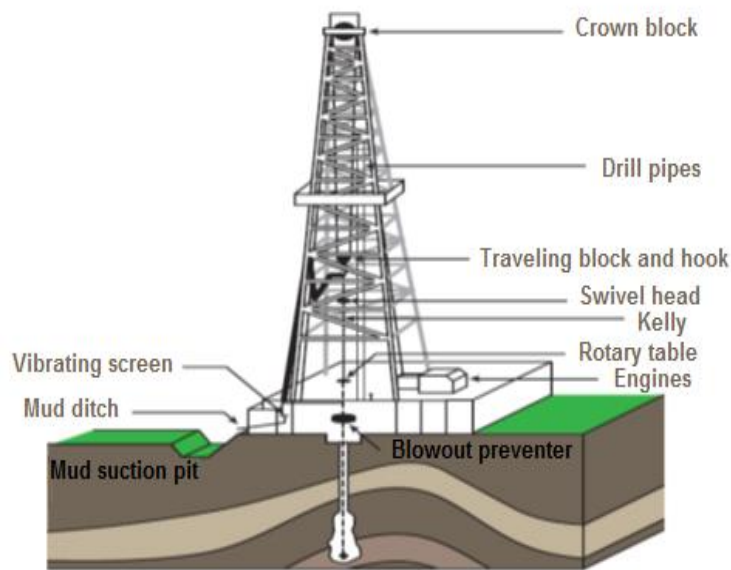

Figure 2.4: Rotary drilling rig

### 2.14.1 The Rotary Drilling Contents

Rotary drilling is characterized as a method of drilling that employs a sharp, rotational drill bit to bite its way through the earth's crust. One of the most effective and common methods of drilling, it is used in the construction, mining, and oil industries for its ability to cut through even the most challenging and hardest formations.

The rotary drill rig consists of:

- ❖ Prime mover
- ❖ Rotating equipment
- ❖ Hoisting equipment

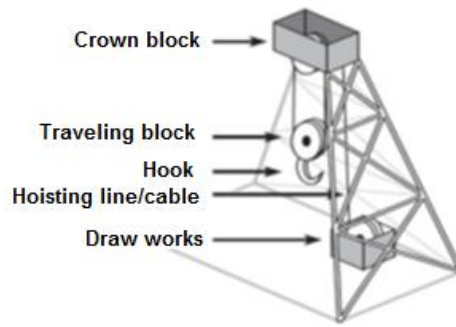

Figure 2.5: Hoisting equipment

## 2.15 Rotating Equipment

At the very start of a drilling operation, one section of round drill pipe is screwed tightly to the bottom end of the Kelly. That first section with a sharp drill bit attached to its lower ends then lowered through the bushing and rotary table until the flat sides at the lower end of the Kelly are seated securely in the Kelly bushing. At that point, the Kelly, bushing, and rotary table begin to rotate as a single unit, powered by the prime mover. The drill bit (turning clockwise when viewed from above) begins to bite into the ground below the derrick. Each drill pipe section is called a joint. Made of heat-treated alloy steel, each section can be from 8 to 45 feet long (commonly 30 feet), with an outside diameter ranging from about 3 to 5.5 inches. Collectively, the downhole drill pipe, the bit, and related equipment comprise the drill string. <sup>[2]</sup>

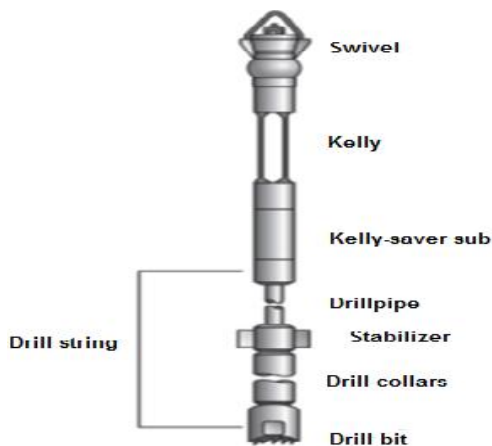

Figure 2.6: Rotating equipment

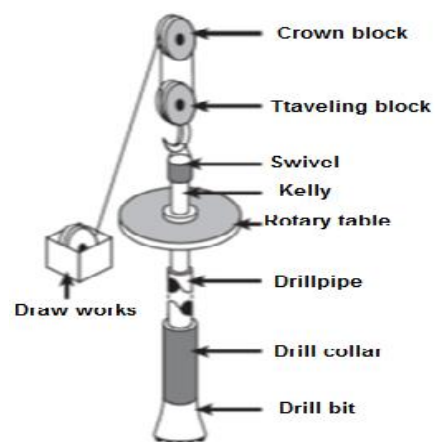

Figure 2.7: Drill string schematic

### **2.15.1 Drill bit**

The business end of a drill string is the drill bit, and different rock layers often require the use of different drill bits to achieve maximum drilling efficiency. Several designs have evolved as companies gained experience drilling in various kinds of geologic formations. Drill bits commonly range in diameter from about 4 to 26 inches. The most common type is the rotary cone bit, and the general design that uses three rotating cones is called a tricone bit. As the drill string turns, the three cones also rotate, and teeth or buttons on the cones either flake or crush rock at the bottom of the well. Typical rotation speeds range from 50 to 100 RPM. There are hundreds of different tricone bit designs, generally classified as either milled-teeth or insert bits. The former are most suitable for rock of soft or medium hardness; the latter are more effective on hard rock.<sup>[2]</sup>

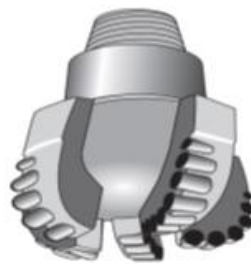

Figure 2.8: Polycrystalline diamond compact drill bit

### **2.15.2 Blowout prevention**

A blowout is the uncontrolled flow of oil or gas up the drill string or wellbore annulus. This is triggered when the formation pressure (exerted by gas or oil in the formation around or at the bottom of the well) exceeds the pressure created by the drilling mud. A blowout can seriously injure workers and damage the drilling rig. As noted above, the drill string is situated in the center of the wellbore, and there is a space (the annulus), typically several inches across, between the outer surface of the drill string and the wall of the well. For prevention of a blowout, it is important to at least cap the annulus. It may also be desirable to seal off the top of the drill string. However, in some

cases, the operator may want to pump heavier mud down the drill string until mud pressure overcomes the pressure exerted by downhole formation fluids.

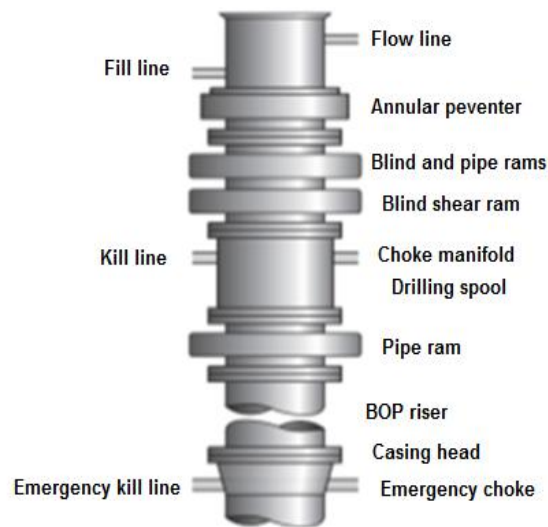

Figure 2.9: Blowout preventer

All Blowout Preventer (BOP) components can be activated separately by hydraulic pressure, maintained in accumulator cylinders. Their operation does not depend on the rig's prime mover. Workers can trigger the BOP from any of several control stations on or near the drilling rig. A final BOP-related component is the choke manifold, a set of flow lines, valves, and chokes connected to the BOP stack. It is routinely used for nonemergency routing of drilling mud from the well to various onsite equipment. However, if the BOP has been activated, it can also be used to relieve well pressure and to circulate heavier drilling mud into the well. <sup>[2]</sup>

## 2.16 Drilling Techniques

Every well operator would like to drill a straight well directly down into the earth, pending the least amount of time and money to reach a subsurface target. In reality, because of the physics of rotary drilling, a straight hole in relatively uniform ground typically has a slight corkscrew configuration, with the drill bit moving downward within a cone whose angle is as large as five

degrees. In most cases, this digression from true vertical is acceptable. There are many of drilling techniques like Directional or Deviated drilling as shown in (figure 2.10) and Extended-reach (ER) drilling as shown in (figure 2.11) and also Horizontal-drain well as shown in (figure 2.12) .

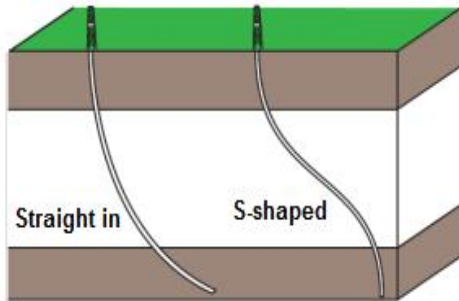

Figure 2.10: Deviated well

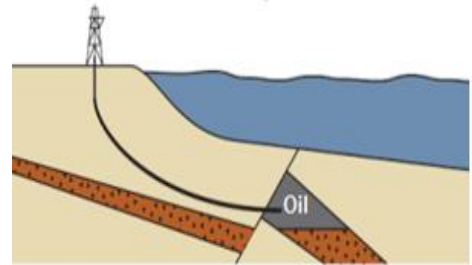

Figure 2.11: Extended reach well

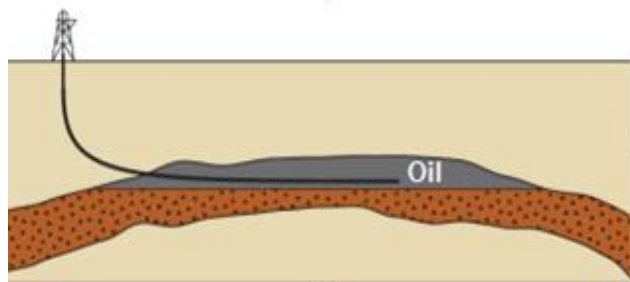

Figure 2.12: Horizontal drain well

## 2.17 The well

Once the well has been drilled, it must be completed. Completing a well consists of a number of steps, such as installing the well casing, completion, installing the wellhead, and installing lifting equipment or treating the formation, if required. <sup>[1]</sup>

### 2.17.1 Well casing

Installing the well casing is an important part of the drilling and completion process. Well casing consists of a series of metal tubes installed in the freshly drilled hole .At a certain stage during the drilling of oil and gas wells, it



becomes necessary to line the walls of a borehole with steel pipe which is called casing. Casing serves numerous purposes during the drilling and production history of oil and gas wells these include:

- ❖ Keeping the hole open by preventing the weak formations from collapsing, caving of the hole.
- ❖ Serving as a high strength flow conduit to surface for both drilling and production fluids.
- ❖ Protecting the freshwater-bearing formations from contamination by drilling and production fluids.
- ❖ Providing a suitable support for wellhead equipment and blowout preventers for controlling subsurface pressure. and for the installation of tubing and subsurface equipment.
- ❖ Providing safe passage for running wire line equipment
- ❖ Allowing isolated communication with selectively perforated formation's of interest. <sup>[3]</sup>

### **2.17.2 Types of casing**

When drilling wells, hostile environments, such as high-pressured zones, weak and fractured formations, unconsolidated formations and sloughing shale's, are often encountered. Consequently, wells are drilled and cased in several steps to seal off these troublesome zones and to allow drilling to the total depth. Different casing sizes are required for different depths, the five general casings used to complete a well are: conductor pipe, surface casing, intermediate casing, production casing and liner. As shown in (figure 2.13) these pipes are run to different depths and one or two of them may be omitted depending on the drilling conditions: they may also be run as liners or in combination with liners. In offshore platform operations, it is also necessary to run a caisson pipe. <sup>[3]</sup>

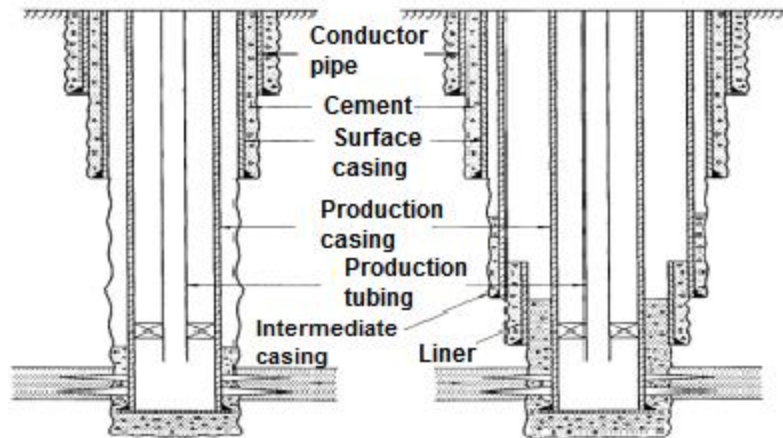

Figure 2.13: Typical casing program showing different casing sizes and their setting depths.

### 2.17.3 Wellheads

The wellhead sits on top of the actual oil or gas well leading down to the reservoir. A wellhead may also be an injection well, used to inject water or gas back into the reservoir to maintain pressure and levels to maximize production. Once a natural gas or oil well is drilled and it has been verified that commercially viable quantities of natural gas are present for extraction, the well must be completed to allow petroleum or natural gas to flow out of the formation and up to the surface. This process includes strengthening the well hole with casing, evaluating the pressure and temperature of the formation, and installing the proper equipment to ensure an efficient flow of natural gas from the well. The well flow is controlled with a choke.

We differentiate between, dry completion (which is either onshore or on the deck of an offshore structure) and subsea completions below the surface. The wellhead structure, often called a Christmas tree, must allow for a number of operations relating to production and well work over. Well work over refers to various technologies for maintaining the well and improving its production capacity.

There are three main types of conventional wells, the most common is an oil well with associated gas. Natural gas wells are drilled specifically for natural gas, and contain little or no oil. Condensate wells contain natural gas, as well as a liquid condensate. This condensate is a liquid hydrocarbon mixture that is often separated from the natural gas either at the wellhead, or during the processing of the natural gas. Depending on the well type, completion may differ slightly. It is important to remember that natural gas, being lighter than air, will naturally rise to the surface of a well. Consequently, lifting equipment and well treatment are not necessary in many natural gas and condensate wells, while for oil wells, many types of artificial lift may be installed, particularly as the reservoir pressure falls during years of production. There is no distinct transition from conventional to unconventional oil and gas production. Lower porosity (tighter reservoirs) and varying maturity create a range of shale oil and gas, tight gas and heavy oil that is simply an extension of the conventional domain.<sup>[1]</sup>

#### **2.17.4 Wellheads equipment's**

The wellhead consists of the pieces of equipment mounted at the opening of the well to regulate and monitor the extraction of hydrocarbons from the underground formation. It also prevents leaking of oil or natural gas out of the well, and prevents blowouts due to high pressure formations. Formations that are under high pressure typically require wellheads that can withstand a great deal of upward pressure from the escaping gases and liquids. These wellheads must be able to withstand pressures of up to 140 MPa (1400 Bar). The wellhead consists of three components: the casing head, the tubing head, and the Christmas tree.

A typical Christmas tree composed of a master gate valve, a pressure gauge, a wing valve, a swab valve and a choke is shown here. The Christmas tree may also have a number of check valves. [1]

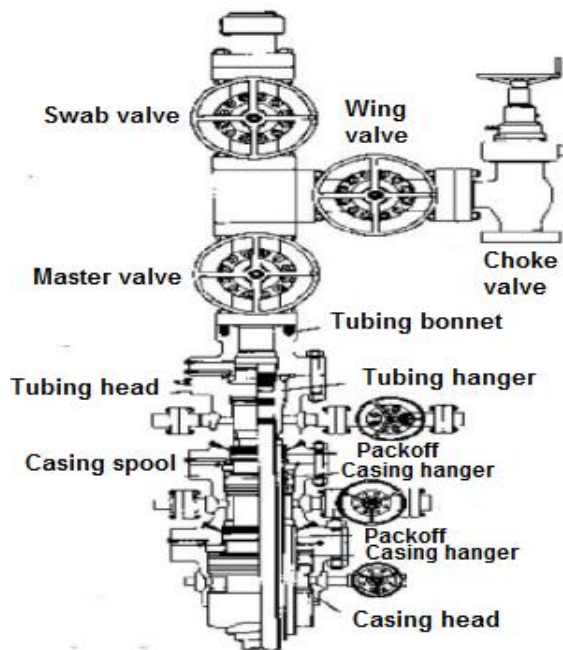

Figure 2.14: Wellhead construction

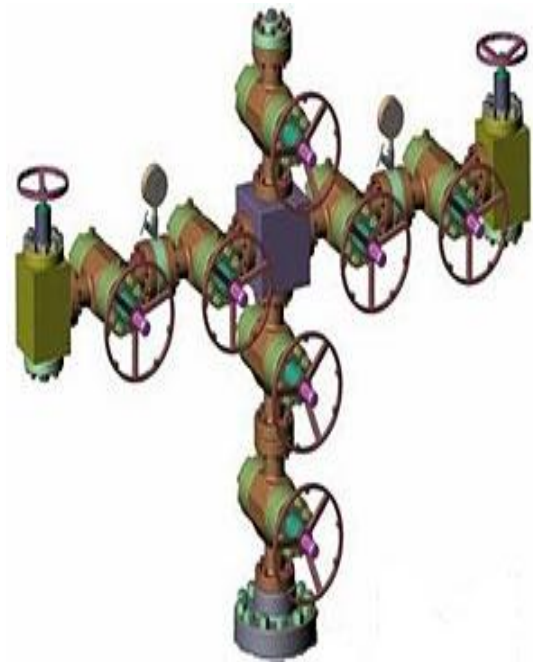

Figure 2.15: Christmas tree

## 2.18 Artificial Lifts

Production wells are free flowing or lifted. A free flowing oil well has enough downhole pressure to reach a suitable wellhead production pressure and maintain an acceptable well-flow. If the formation pressure is too low, and water or gas injection cannot maintain pressure or is not suitable, then the well must be artificially lifted. For smaller wells, 0.7 MPa (100 PSI) wellhead pressure with a standing column of liquid in the tubing is considered a rule-of-thumb to allow the well to flow. Larger 31 wells will be equipped with artificial lift to increase production even at much higher pressures. Some artificial lift methods are:

### 2.18.1 Rod pumps

Sucker Rod Pumps, also called Donkey pumps or beam pumps, are the most common artificial-lift system used in land-based operations. Motor drives a reciprocating beam, connected to a polished rod passing into the tubing via a stuffing box. The sucker rod continues down to the oil level and is connected to a plunger with a valve. On each upward stroke, the plunger lifts a volume

of oil up and through the wellhead discharge. On the downward stroke it sinks (it should sink, not be pushed) with oil flowing through the valve. The motor speed and torque is controlled for efficiency and minimal wear with a Pump off Controller (POC). Use is limited to shallow reservoirs down to a few hundred meters, and flows up to about 40 liters (10 gal) per stroke.<sup>[1]</sup>

### 2.18.2 Downhole pumps

Downhole pump insert the whole pumping mechanism into the well. In modern installations, an Electrical Submerged Pump (ESP) is inserted into the well. Here the whole assembly consisting of a long narrow motor and a multi phase pump, such as a Progressive Cavity Pump (PCP) or centrifugal pump, hangs by an electrical cable with tension members down. Installations down to 3.7 km with power up to 750 kW have been installed. At these depths and power ratings, Medium Voltage drives (up to 5kV) must be used. ESPs works in deep reservoirs, but lifetime is sensitive to contaminants such as sand, and efficiency is sensitive to Gas Oil Ratio (GOR) where gas over 10% dramatically lowers efficiency.<sup>[1]</sup>

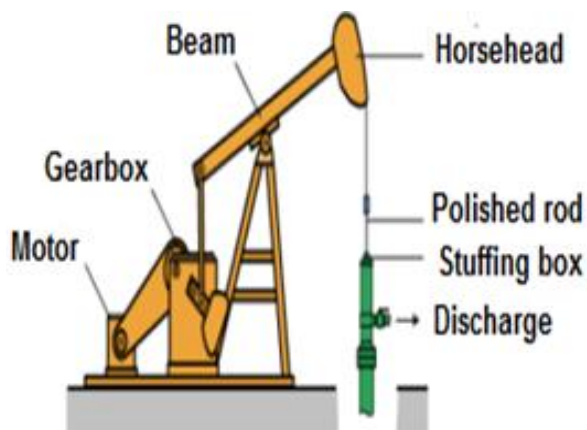

Figure 2.16 : Sucker (rod) pump

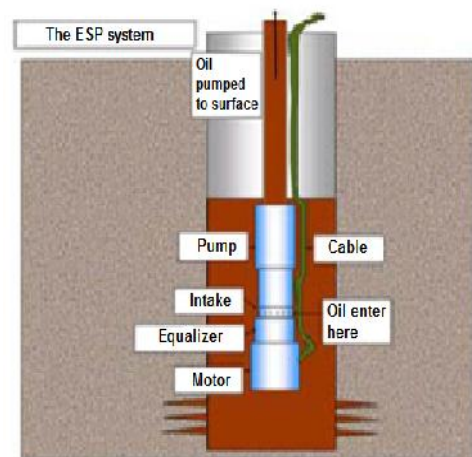

Figure 2.17 : Downhole pump

### 2.18.3 Types of downhole pumps

Downhole pump insert the whole pumping mechanism into the well. In modern installations, an Electrical Submerged Pump (ESP) is inserted into the well. Here the whole assembly consisting of a long narrow motor and a multi-phase pump, such as a Progressive Cavity Pump (PCP) or centrifugal pump, hangs by an electrical cable with tension members down the tubing. The Electrical Submerged Pump (ESP) is shown in (figure 2.18) it shows a tubing-hung unit with the downhole components comprising of:

- ❖ A multistage centrifugal pump with either an integral intake or separate, bolt-on intake.
- ❖ A seal-chamber section.
- ❖ A three-phase induction motor, with or without a sensor package.

The rest of the system includes a surface control package and a three-phase power cable running downhole to the motor. Because of the ESP's unique application requirement in deep, relatively small-bore casings, the equipment designer and manufacturer are required to maximize the lift of the pump and the power output of the motor as a function of the diameter and length of the unit. Therefore, the equipment is typically long and slender. The components are manufactured in varying lengths up to approximately 30 ft, and for certain applications, either the pump, seal, or motor can be multiple components connected in series. The Components of an ESP system:

- ❖ ESP centrifugal pump.
- ❖ ESP seal section.
- ❖ ESP motors.
- ❖ ESP power cable.
- ❖ ESP surface motor controllers.
- ❖ ESP optional component.

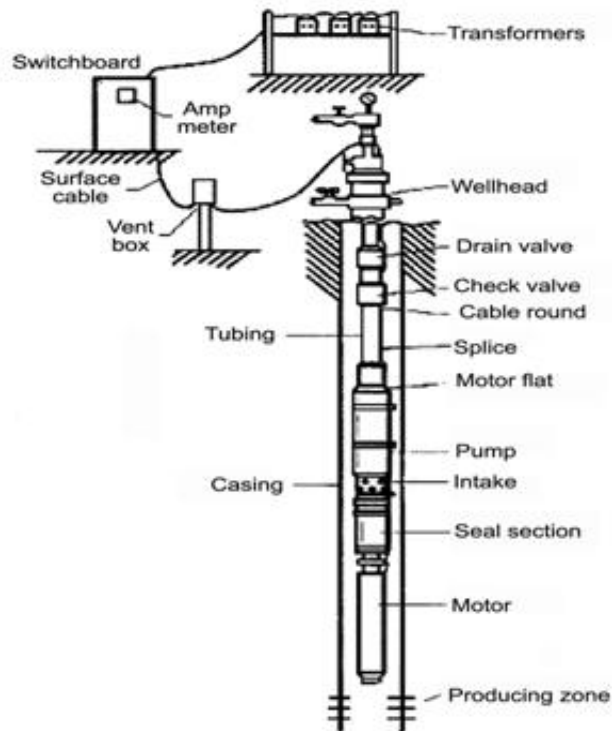

Figure 2.18: Schematic of typical ESP pump system

Throughout their history, ESP systems have been used to pump a variety of fluids. Normally, the production fluids are crude oil and brine, but they may be called on to handle:

- ❖ Liquid petroleum products.
- ❖ Disposal or injection fluids.
- ❖ Fluids containing free gas.
- ❖ Some solids or contaminants.
- ❖ CO<sub>2</sub> and H<sub>2</sub>S gases or treatment chemicals.

ESP systems are also environmentally esthetic because only the surface power control equipment and power cable run from the controller to the wellhead are visible. The controller can be provided in a weatherproof, outdoor version or an indoor version for placement in a building or container. The control equipment can be located within the minimum recommended distance from the wellhead, or if necessary up to several miles away.

ESPs provide a number of advantages like:

- ❖ Adaptable to highly deviated wells; up to horizontal, but must be set in straight section.
- ❖ Permit use of minimum space for subsurface controls and associated production facilities.
- ❖ Quiet, safe, and sanitary for acceptable operations in an offshore and environmentally conscious area.
- ❖ Generally considered a high-volume pump.
- ❖ Applicable in a range of harsh environments.

ESPs have some disadvantages that must be considered:

- ❖ Will tolerate only minimal percentages of solids (sand) production, although special pumps with hardened surfaces and bearings exist to minimize wear and increase run life.
- ❖ Costly pulling operations and lost production occur when correcting downhole failures, especially in an offshore environment.
- ❖ Below approximately 400 B/D, power efficiency drops sharply; ESPs are not particularly adaptable to rates below 150 B/D.
- ❖ Need relatively large (greater than 4½-in. outside diameter) casing size for the moderate- to high-production-rate equipment.

Downhole pump insert also Progressive Cavity Pump (PCP) as shown in (figure 2.19), Progressive Cavity Pump is becoming increasingly popular for the production of viscous crude oils. (Well rates & depths) where Progressing Cavity Pumps (PCP) are typically employed. A typical completion is illustrated in (figure 2.19) where a prime mover (in this case an electric motor) is shown rotating a sucker rod string and driving the PCP. This section will describe the principle on which the pump operates, the resulting advantages and disadvantages and, finally, takes a look at new technology.



### 2.18.4 Progressing cavity pumps principles

A steel shaft rotor of diameter  $d$  has been formed into a helix. The rotor is rotated inside an elastomeric pump body or stator, which has been molded in the form of a double helix with a pitch of the same diameter and exactly twice the length of the pitch given to the rotor. When assembled, the centre line of the rotor and the stator are slightly offset, creating a series of fluid filled cavities along the length of the pump. The interference fit between the rotor and stator creates two chains of spiral (fluid filled) cavities.

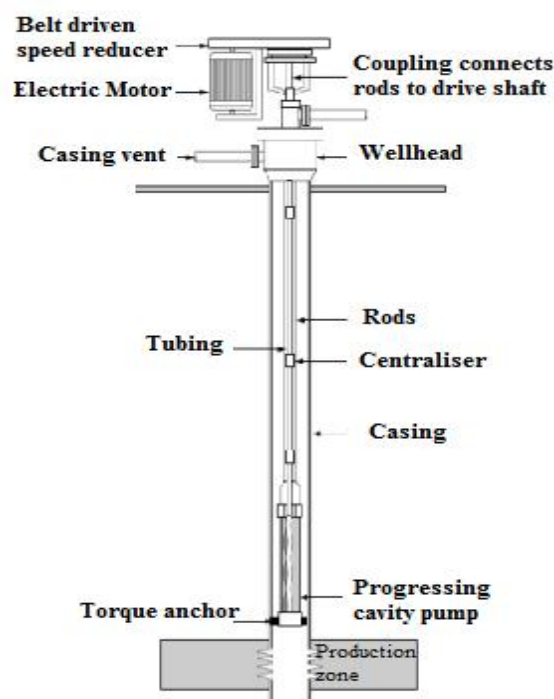

Figure 2.19: Progressing cavity pumps

### 2.19 Smart Relay

Smart relay is a micro Programmable Logic Controller (PLC). In order to talk about smart relay we must start with the ordinary relay. A relay is usually an electromechanical device that is actuated by an electrical current. The current flowing in one circuit causes the opening or closing of another circuit. Relays are like remote control switches and are used in many applications because of their relative simplicity, long life, and proven high reliability. Relays are used in a wide variety of applications throughout industry, such as in telephone

exchanges, digital computers and automation systems. Highly sophisticated relays are utilized to protect electric power systems against trouble and power lack outs as well as to regulate and control the generation and distribution of power. In the home, relays are used in refrigerators, washing machines and dishwashers, and heating and air-conditioning controls. Although relays are generally associated with electrical circuitry, there are many other types, such as pneumatic and hydraulic. Input may be electrical and output directly mechanical, or vice versa. Protective relays are the tools of the protection engineer. As in any craft, an intimate knowledge of the characteristics and capabilities of the available tools is essential to their most effective use. Therefore, we shall spend some time learning about these tools without too much regard to their eventual use. <sup>[4]</sup>

### 2.19.1 Types of relays

There are two basic classifications of relays, Electromechanical and Solid State. Electromechanical relays have moving parts, whereas solid state relays have no moving parts. Advantages of Electromechanical relays include lower cost, no heat sink is required, multiple poles are available, and they can switch AC or DC with equal ease. <sup>[4]</sup>

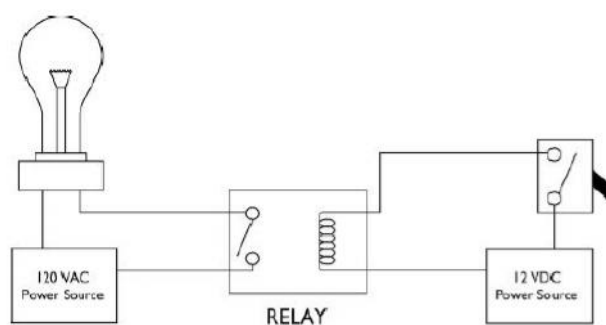

Figure 2.20: Sample diagram of work principle of the relay

Due to the obstacles facing operations managers in changing a machine behavior in a continuous production line controlled by relay logic changing

the connections of the control circuit physically which cost a lot of time. An alternative has to be introduced .<sup>[4]</sup>

## **2.20 Programmable Logic Controllers (PLC)**

Programmable logic controllers, also called programmable controllers or PLCs. PLCs are solid-state members of the computer family using integrated circuits instead of electromechanical devices to implement control functions.

They are capable of storing instructions, such as sequencing, timing, counting, arithmetic, data manipulation , and communication to control industrial machines and processes. The Programmable logic controllers have many advantages :

- ❖ Cost effective for controlling complex systems.
- ❖ Flexible and can be reapplied to control other systems quickly and easily.
- ❖ Computational abilities allow more sophisticated control.
- ❖ Trouble shooting aids make programming easier and reduce downtime.
- ❖ Reliable components make these likely to operate for years before failure.

PLC's can be classified in many ways. Base on the features and size

PLC types can be classified into following class:

- ❖ Micro PLCs.
- ❖ Small PLCs.
- ❖ Medium PLCs.
- ❖ Large PLCs.
- ❖ Very large PLCs.

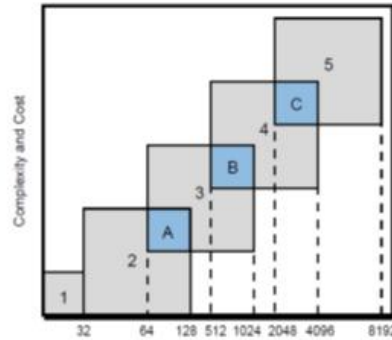

Figure 2.21: PLC product range

Micro PLCs are used in applications controlling up to 32 input and output devices, 20 or less I/O being the norm. The micros are followed by the small PLC category, which controls 32 to 128 I/O. The medium (64 to 1024 I/O), large (512 to 4096 I/O), and very large (2048 to 8192 I/O) PLCs complete the segmentation. (figure 2.21) shows several PLCs that fall into this category classification. A programmable controller as illustrated in (figure 2.22) consists of two basic sections the central processing unit and the input/output interface system.

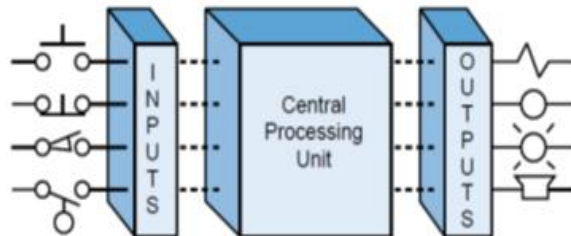

Figure 2.22 : PLC block diagram

The central processing unit (CPU) governs all PLC activities. The following three components, shown in (figure 2.23) :

- ❖ The processor.
- ❖ The memory system.
- ❖ The system power supply.

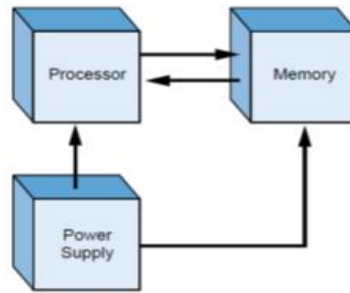

Figure 2.23 : Block diagram of major CPU components

### 2.20.1 Micro PLCs (smart relay)

Smart relay classified as a micro plc so we will go deeply into micro plc type. A recent innovation has been the introduction of very small PLCs with a limited number of inputs and outputs. These have been designed for applications such as greasing, heating and air conditioning systems where the programs are written once then installed and sold as part of the final product or system. In many cases the end-user will not be aware that a PLC is controlling the system. The low price of these micro PLCs makes them very cost effective even compared to one or two relays. Smart relays are designed to simplify the electrical wiring of intelligent solutions. A smart relay is very simple to implement. Its flexibility and its high performance allows users to save significant amounts of time and money.

### 2.20.2 Smart relay interface

The main purpose of the smart relay is to provide automated control of small devices. This range consists of: compact smart relays with 10, 12 or 20 Inputs/ Outputs, with or without a display unit; modular smart relays with 10 or 26 Inputs / Outputs and expansion modules with 4, 6, 10 or 14 Inputs / Outputs, communication expansion modules (Modbus, Ethernet, Modem interface).<sup>[5]</sup>

Smart relay can be programmed by :

- ❖ Ladder diagram.
- ❖ Block function diagram.<sup>[5]</sup>

Smart relays are designed for use in small automated systems. They are used in both the industrial and commercial sectors. [5] For industry automation of small finishing, production, assembly or packaging machines, decentralized automation of ancillary equipment of large and medium-sized machines (textile, plastics, materials processing sectors) automation systems for agricultural machinery (irrigation, pumping, greenhouses). Also For the commercial/building sectors automation of barriers, roller shutters, access control, automation of lighting systems, automation of compressors and air conditioning systems. Their compact size and ease of setting-up make them a competitive alternative to solutions based on cabled logic or specific cards. [5]



Figure 2.24 : Smart relay

## 2.21 Variable Speed Drive (VSD)

Variable Speed Drives (VSDs) are intended for speed control of three-phase induction motors in a wide variety of industrial applications. The Variable Speed Drive (VSD) offers state of the art technology in motor control with a modern design, great number of features, and easy installation and operation. Variable Speed Drive (VSD) usage has increased dramatically in High Voltage alternating Current (HV-AC) applications. The Variable Speed

Drives (VSDs) are now commonly applied to air handlers and pumps, chillers. A better understanding of Variable Speed Drives (VSDs) will lead to improved application and selection of both equipment and High Voltage alternating Current (HVAC) systems. Common High Voltage alternating Current (VSD) Terms There are several terms used to describe devices that control speed. <sup>[6]</sup> There are different meanings of Variable Speed depending on the control method:

❖ Variable Frequency Drive (VFD)

This device uses power electronics to vary the frequency of input power to the motor, thereby controlling motor speed.

❖ Variable Speed Drive (VSD)

This more generic term applies to devices that control the speed of either the motor or the equipment driven by the motor (fan, pump, and compressor). This device can be either electronic or mechanical.

❖ Adjustable Speed Drive (ASD)

Again, a more generic term applying to both mechanical and electrical means of controlling speed. <sup>[6]</sup>

### **2.21.1 Types of control in variable speed drive**

The type of control used in VSD control systems follows an approach similar to that used in normal industrial process control. The level of control can be Simple open-loop control (no feedback from the process), or Closed-loop control (feedback of a process variable) Cascade closed-loop control (feedback from more than one variable)

❖ Open-Loop Control

The purpose of an electrical VSD is to convert the electrical energy of the mains power supply into the mechanical energy of a load at variable speed and torque. In many applications, VSDs are simply required to control the speed of the load, based on a set point command provided by an operator or a

process controller. Conventional Variable Voltage Variable Frequency (VVVF) converters are voltage source devices, which control the magnitude and frequency of the output voltage. The current that flows depends on the motor conditions and load, these are not controlled by the AC converter, but are the result of the application of voltage. The only current control that is exercised is to limit the current when its magnitude reaches a high level, for example at 150% of full load current. There is no provision made for feedback of speed information from the motor to check if it is running at the required speed or if it is running at all. If the load torque changes, and slip increases or decreases, the converter would not adjust its output to compensate for these changes in the process. This method of open-loop control is adequate for controlling steady-state conditions and simple applications, such as centrifugal pumps & fans or conveyors, which allow a lot of time for speed changes from one level to another and where the consequences of the changes in the process are not severe.<sup>[7]</sup>

#### ❖ Closed-Loop Control

In industry, there are also those more difficult applications, where speed and/or torque must be continuously and accurately controlled. The required accuracy of the control is important and can have a large influence on the choice of drive technology. For those drive applications that require tight dynamic control, closed-loop control is necessary. This type of performance can be achieved with closed loop vector control AC drives and standard DC drives. Standard Variable Voltage variable Frequency AC drives can be used in closed-loop control systems, such as pumping systems, which regulate pressure or flow, but in general these applications are not capable of high performance.<sup>[7]</sup>



## 2.21.2 Component of variable speed drive

The variable speed drive consist many Device on it and we will review many of them.

- ❖ AC/DC converter(Rectifier)  
For converting the 3-phase AC voltage to DC voltage of constant amplitude.
- ❖ The DC link  
Usually comprising a DC choke, DC capacitor and a DC bus, for maintaining a smooth fixed DC voltage for the inverter stage.
- ❖ The DC/AC inverter  
For converting the DC voltage to a variable frequency variable voltage AC output.
- ❖ The power supply modules:  
For providing power to the control circuits for the interface system and the inverter switches.
- ❖ The digital control system:  
Comprising the sequence control, internal control loops, protection circuits and user interfaces.

Most modern AC variable speed drives (VSDs) are of modular construction. Some of the technical details of the main components, such as the input rectifier, DC link, output inverter and the connected. <sup>[7]</sup>

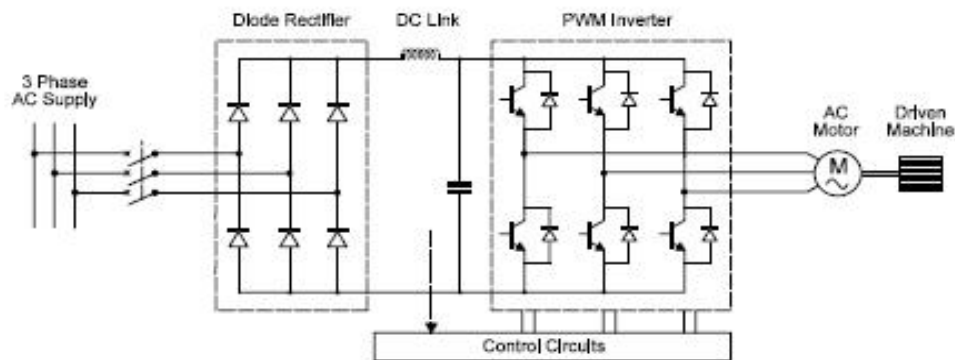

Figure 2.25: Internal structure for the VSD

## 2.22 Variable Speed Drive Operation

Understanding the basic principles behind VSD operation requires understanding the three basic sections of the VSD: the rectifier, dc bus, and inverter. The voltage on an alternating current (AC) power supply rises and falls in the pattern of a sine wave. When the voltage is positive, current flows in one direction; when the voltage is negative, the current flows in the opposite direction. This type of power system enables large amounts of energy to be efficiently transmitted over great distances. The rectifier in a VSD is used to convert incoming ac power into direct current (DC) power. One rectifier will allow power to pass through only when the voltage is positive. A second rectifier will allow power to pass through only when the voltage is negative. Two rectifiers are required for each phase of power. Since most large power supplies are three phase, there will be a minimum of 6 rectifiers used (figure2.26).<sup>[6]</sup>

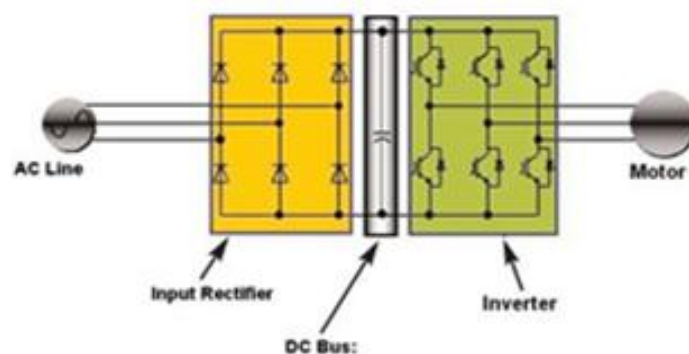

Figure 2.26: VSD basic existing technology

Appropriately, the term 6 pulse is used to describe a drive with 6 rectifiers. A VSD may have multiple rectifier sections, with 6 rectifiers per section, enabling a VSD to be 12 pulses, 18 pulses or 24 pulses. The benefit of multi pulse VSDs will be described later in the harmonics section. Rectifiers may utilize diodes, silicon controlled rectifiers (SCR), or transistors to rectify power. Diodes are the simplest device and allow power to flow any time voltage is of the proper polarity. Silicon controlled rectifiers include a gate circuit that enables a microprocessor to control when the power may begin to

flow, making this type of rectifier useful for solid-state starters as well. Transistors include a gate circuit that enables a microprocessor to open or close at any time, making the transistor the most useful device of the three. A VSD using transistors in the rectifier section is said to have an active front end. After the power flows through the rectifiers it is stored on a dc bus. The dc bus contains capacitors to accept power from the rectifier, store it, and later deliver that power through the inverter section. The dc bus may also contain inductors, dc links, chokes, or similar items that add inductance, thereby smoothing the incoming power supply to the dc bus. The final section of the VSD is referred to as an inverter. The inverter contains transistors that deliver power to the motor. The Insulated Gate Bipolar Transistor (IGBT) is a common choice in modern VSDs. The IGBT can switch on and off several thousand times per second and precisely control the power delivered to the motor. The IGBT uses a method named pulse width modulation (PWM) to simulate a current sine wave at the desired frequency to the motor. <sup>[6]</sup> The Variable Speed Drive has Advantages:

- ❖ Energy savings.
- ❖ Low motor starting current.
- ❖ High power factor.
- ❖ Lower KVA.<sup>[6]</sup>

# CHAPTER THREE

## THE CIRCUIT

The practical Auto Restart Circuit constructed in order to bear harsh working environment but we designed a simulation circuit to simulate the practical circuit. The main components of the two circuits were shown below:

### 3.1 Real circuit

The real Auto Restart Circuit consists of :

- ❖ Variable Speed Drive (VSD).
- ❖ Smart Relay.
- ❖ Alternating Current (AC) Motor.

### 3.2 Simulation circuit

The simulation Circuit consists of :

- ❖ Microcontroller AVR (atmega16).
- ❖ Voltage Regulator (5VDC).
- ❖ Universal Linear Driver (ULN 2802A).
- ❖ Liquid Crystal Display (LCD) (16×2).
- ❖ Switches.
  - ✓ Pushbutton Switch and Selector Switch.
- ❖ Resistors.
  - ✓ Variable Resistor and Static Resistor.
- ❖ Capacitors.
- ❖ Infrared (IR) Led Transmitter and Receiver.
- ❖ Direct Current (DC) Motor.

### 3.3 Variable Speed Drive (VSD)

VSD is a device that controls the speed of either the motor or the equipment driven by the motor, the necessity of the VSD is to protect the shaft by smoothing the start operation of the motor and a safety function that is designed to ensure that the motor has stopped and prevent accidental restarts. VSD is the main component of the practical Auto Restart Circuit and the driver of the PCP pump. [7]



Figure 3.1: Shows the variable speed drive

### 3.4 Smart Relay

Smart relays are designed to simplify the electrical wiring of intelligent solutions. A smart relay is very simple to implement. Its flexibility and its high performance allow users to save significant amounts of time and money. Smart relay is a micro plc used to control the operation of the circuit by auto restarting the VSD in the blackout situation. Smart relay programmed with ladder diagram. [8]

Smart relay used to control the operation of auto restart which needs a device acting as a controller that detects the interruption of the electricity and performs the time delay automatically. [8]

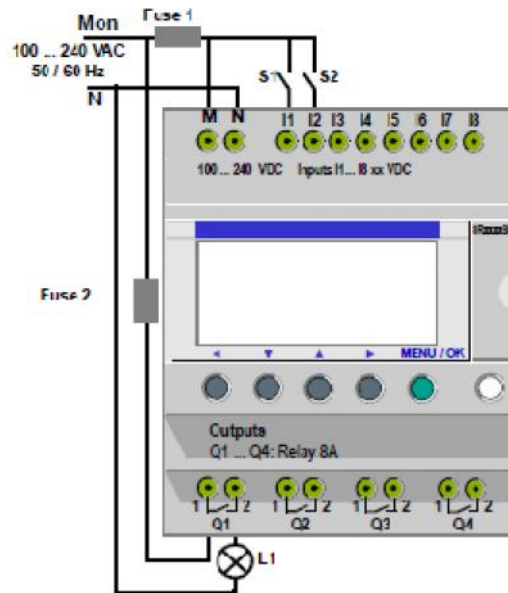

Figure 3.2: Shows the smart relay

### 3.5 Alternating Current (AC) Motor

An electric motor that driven by alternating current. The AC Motor is used in the conversion of electrical energy into mechanical energy. This mechanical energy is made from utilizing the force that is exerted by the rotating magnetic fields produced by the alternating current that flows through its coils. The AC Motor is made up of two major components: the stationary stator that is on the outside and has coils supplied with AC current, and the inside rotor that is attached to the output shaft. AC Motors classified to two basic types Synchronous motors and Asynchronous motors which it is divided into two types Induction motors and Commentator motors.

Induction AC Motors are referred to as asynchronous motors or rotating transformers. This type of AC Motor uses electromagnetic induction to power the rotating device which is usually the shaft. The rotor in induction AC motor products typically turns slower than the frequency that is supplied to it. Induced current is what causes the magnetic field that envelops the rotor of these motors. This Induction AC Motor is designed in one or three phases.

PCP pump is driven by an AC induction motor which is controlled by the practical Auto Restart Circuit. <sup>[17]</sup>

### **3.6 Microcontroller**

An integrated circuit that contains many of the same items that a desktop computer has, such as Central Processing Unit (CPU), memory, but does not include any (human interface) devices like a monitor, keyboard, or mouse. Microcontrollers are designed for machine control applications, rather than human interaction.

ATmega16 is a Low-Power Complementary Metal–Oxide–Semiconductor (CMOS) 8-bit microcontroller based on the Alf (Egil Bogen) and Vegard (Wollan)'s RISC processor (AVR) enhanced Reduced Instruction Set Computer (RISC) architecture. By executing powerful instructions in a single clock cycle, the ATmega16 achieves through puts approaching 1 Million Instructions Per Second (MIPS) allowing the system designed to optimize power consumption versus processing speed. ATmega16 has 16 KB programmable flash memory, static Random Access Memory (RAM) of 1 KB and Electrically Erasable Programmable Read-Only Memory (EEPROM) of 512 Bytes. The endurance cycle of flash memory and EEPROM is 10,000 and 100,000, respectively. ATmega16 is a 40 pin microcontroller. There are 32 Input/output (I/O) lines which are divided into four 8-bit ports designated as PORTA, PORTB, PORTC and PORTD. It has various in-built peripherals like Analog to Digital Converter (ADC), Analog Comparator and Serial Peripheral Interface (SPI). Each I/O pin has an alternative task related to in-built peripherals. The following (figure 3.3) shows the pin description of ATmega16. <sup>[9]</sup>

The microcontroller in our circuit plays an important role as the control brain of the circuit and we used it to simulate the Variable Speed Drive (VSD) and smart relay work.

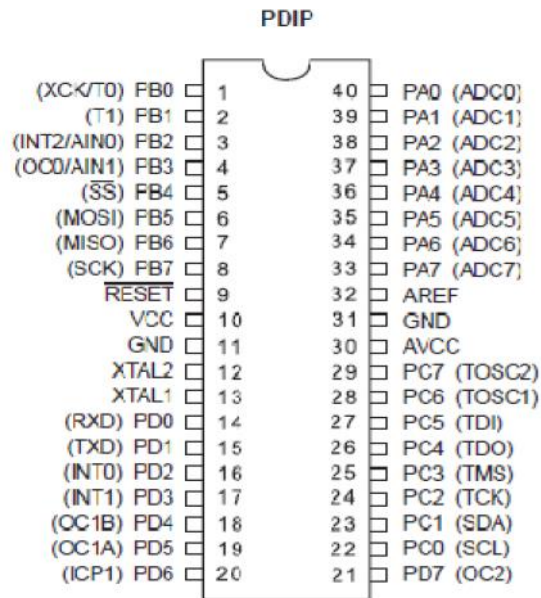

Figure 3.3: Microcontroller atmega16

### 3.7 Voltage Regulator

Voltage Regulator generates a fixed output voltage of a preset magnitude that remains constant regardless of hangs to its input voltage or load conditions. <sup>[9]</sup>

The L78XX series of three-terminal positive regulators and is several fixed output voltages, making it useful in a wide range of applications. These regulators can provide local on-card regulation, eliminating the distribution problems associated with single point regulation. Each type embeds internal current limiting, thermal shutdown and safe area protection, making it essentially indestructible. If adequate heat sinking is provided, they can deliver over 1 A output current. Although designed primarily as fixed voltage regulators, these devices can be used with external components to obtain adjustable voltage and currents. <sup>[11]</sup>

We used the voltage regulator to regulate the voltage from 12VDC to 5VDC. 5VDC output used to feed the microcontroller .We will connect the pin 1 at the input voltage and pin 2 to the ground and we will get the output voltage in pin 3



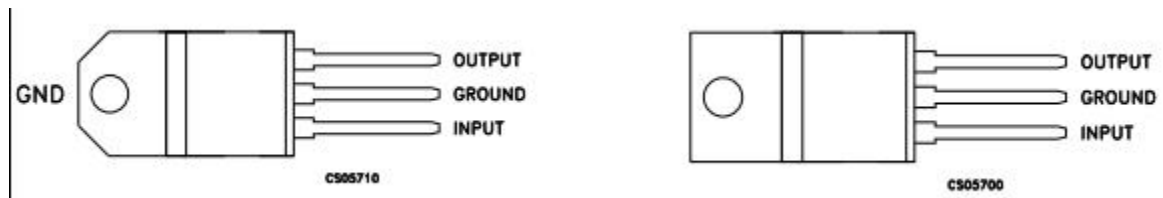

Figure 3.4: Regulator L78XX

### 3.8 Universal Linear Driver (ULN 2802A)

High-Voltage, High-Current Darlington transistor arrays. Each consists of eight Negative-Positive-Negative (NPN) Darlington pairs that feature high-voltage outputs with common-cathode clamp diodes for switching inductive loads. These versatile devices are useful for driving a wide range of loads including solenoids, relays DC motors, Light Emitting Diode (LED) displays filament lamps, thermal print heads and high power buffers. The ULN2802A are supplied in 18 pin plastic Dual Inline Package (DIP) with a copper lead frame to reduce thermal resistance. <sup>[12]</sup>

ULN 2802A connected between the microcontroller and the 12VDC motor. It receives a 5VDC signal from the microcontroller to drive the 12VDC motor.

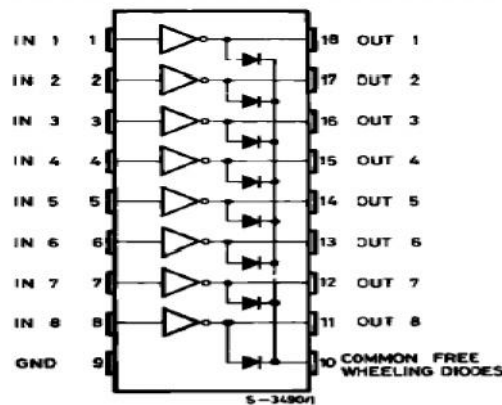

Figure 3.5: ULN 2802A circuit

### 3.9 Liquid Crystal Display (LCD)

A Liquid Crystal Display (LCD) monitor is a computer monitor or display that uses LCD technology to show clear images, and is found mostly in laptop computers and flat panel monitors. This technology has replaced the

traditional Cathode Ray Tube (CRT) monitors, which were the previous standard and once were considered to have better picture quality than early LCD variants. With the introduction of better LCD technology and its continuous improvement, LCD is now the clear leader over CRT, in terms of color and picture quality, not to mention capabilities for large resolutions. Also, LCD monitors may be made much more cheaply than CRT monitors.<sup>[12]</sup> LCD is the monitor of our circuit that we can read the state of the operation from it. To get the display working requires eight bits of data, a Register Select line (RS) and a Strobe line (E). These are supplied from the PC printer port (refer to schematic). A third input, Read /Write (R/W), is used to read or write data to/from the LCD. In this kit the R/W line is tied low so only writes to the LCD are possible (more on this later). The eight bits of data are supplied from the printer port data lines and two printer port control lines are used for RS ('auto') and E ('strobe'). Basically the LCD has two registers, a data register and a control register. Data is written into the control register when RS is low and into the data register when RS is high. Data is latched into the LCD register on the falling edge of 'Enable'.<sup>[13]</sup>

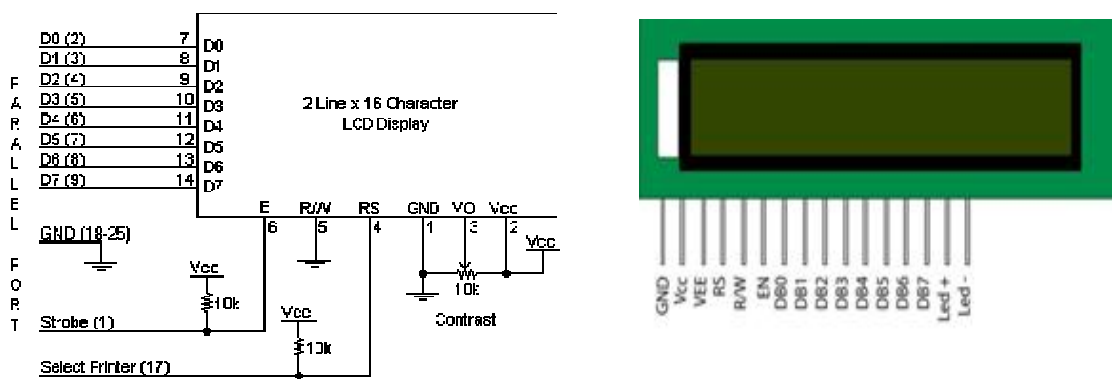

Figure 3.6: Liquid crystal display

### 3.10 Infrared (IR) Led Transmitter and Receiver

The simulated auto restart circuit uses the IR sensors to detect the motion of the motor. IR sensors constructed with two parts IR Transmitter and IR Receiver.

#### 3.10.1 IR Transmitter

An IR Emitter is a LED as shown in (figure 3.7.1). Different types of IR LEDs are specified based on their packaging and special features, such as output optical power, wavelength, and response time. <sup>[14]</sup>

#### 3.10.2 IR Receivers

IR Receivers are also called sensors since they detect the wavelength and spectral radiation of the light from the IR emitter as shown in (figure 3.7.1). IR receivers are specified by optic features, packaging, special circuitry such as an ambient light filter, wide viewing angle, and more. <sup>[14]</sup>

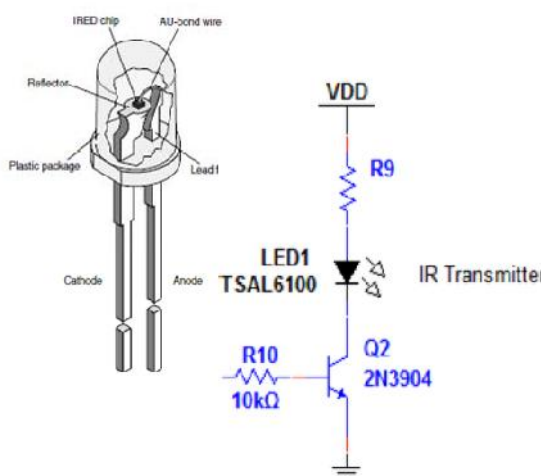

Figure 3.7.1: IR transmitter

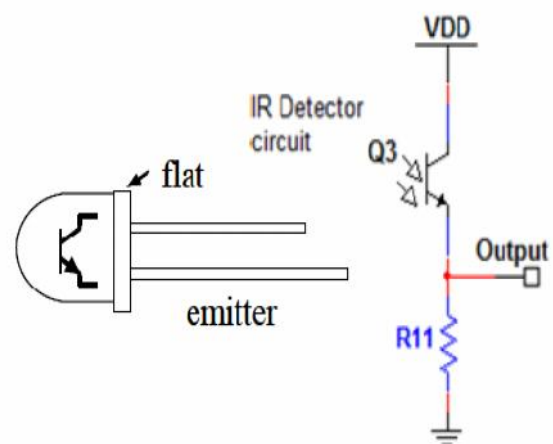

Figure 3.7.2: IR receiver

The frequency range and wavelengths of the entire spectrum are shown in (figure 3.8). The IR portion of the electromagnetic spectrum is usually divided into three regions: the near-, mid- and far- infrared. The wavelengths for these regions are shown in Table. Infrared wavelengths range from red to

violet. The frequencies are higher than microwave but shorter than visible light. Focusing on near infrared devices and applications, Photo Optic technologies are used for optical sensing and optical communications with numerous general market applications. <sup>[14]</sup>

IR sensor used to detect the motion of the motor to make sure that the motor stopped rotating to begin the restart operation. It connected to pin16 (int0).

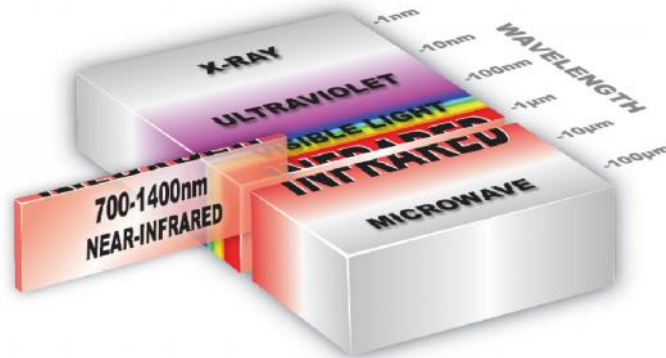

Figure 3.8: The frequency range and wavelengths

### 3.11 Switches

Switches are mechanical devices with two or more leads (or terminals) that are internally connected to metal contacts which can be opened or closed by the person operating the switch. Switches are an important part of most electronic circuits. In the simplest case, most circuits contain an on/off switch. In addition to the on/off switch, many circuits contain switches that control how the circuit works or activate different features of the circuit. Switches have a several types according to their construction such as slide switch, toggle switch, rotary switch and pushbutton switch. <sup>[15]</sup>

We used two types of switches in our circuit. Slide switch and pushbutton. The first one used to switch on and off the whole circuit, the other one used to simulate the real circumstances of the field (black out condition).

### **3.12 Resistors**

The resistor is an electronic component that has electrical friction. This friction opposes the flow of electrons and thus reduces the voltage (pressure) placed on other electronic components by restricting the amount of current that can pass through it. When a person designs a circuit in electronics, it is often necessary to limit the amount of electrons or current that will move through that circuit each second. This is similar to the way a faucet limits the amount of water that will enter a glass each second. It would be very difficult to fill a glass without breaking it if the faucet had only two states, wide open or off. By using the proper value of resistance in an electronic circuit designers can limit the pressure placed on a device and thus prevent it from being damaged or destroyed. There are many types of resistor such as Carbon Composition Resistor, Wire Wound Resistor, Variable Resistor and Metal film resistors. <sup>[16]</sup>

We used Resistors in our circuit are in different locations and it limits the voltage and current to protect the circuit components.

### **3.13 Capacitors**

A capacitor stores electrical energy when charged by a DC source. It can pass alternating current (AC), but blocks direct current (DC) except for a very short charging current, called transient current. When a capacitor has a difference in voltage (Electrical Pressure) between its two leads it is said to be charged. A capacitor is charged by forcing a one way (DC) current to flow through it for a short period of time. It can be discharged by letting an opposite direction current flow out of the capacitor. Capacitors are grouped according to their dielectric material and mechanical configuration Ceramic Capacitors, Film Capacitors, Mica Capacitors, Paper-Foil-Filled Capacitors and Electrolytic Capacitors. <sup>[16]</sup>

The use of Capacitor in our circuit is to smooth and stabilize the dc voltage. In our circuit we have two capacitor one connected in parallel with the voltage regulator and the other with the microcontroller.

### 3.14 Direct Current (DC) Motor

An Electric motor is a machine which converts electric energy into mechanical energy. Its action is based on the principle that when a current-carrying conductor is placed in a magnetic field, it experiences a mechanical force whose direction is given by Fleming's Left-hand Rule.

There is no basic difference between a DC. Generator and a DC motor in fact is the same DC machine can be used interchangeably as a generator or as a motor. DC motors are also like generators, shunt wound or series-wound or compound-wound are a part of multi-polar DC motor is shown. When its field magnets are excited and its armature conductors are supplied with current from the supply mains, they experience a force tending to rotate the armature. Armature conductors under *N*-pole are assumed to carry current downwards (crosses) and those under *S*-poles, to carry current upward (dots). By applying Fleming's Left-hand Rule, the direction of the force on each conductor can be found. It is shown by small arrows placed above each conductor. It will be seen that each conductor can be found. It will be seen that each conductor experiences a force  $F$  which tends to rotate the armature in anticlockwise direction. These forces collectively produce a driving torque which sets the armature rotating. <sup>[17]</sup>

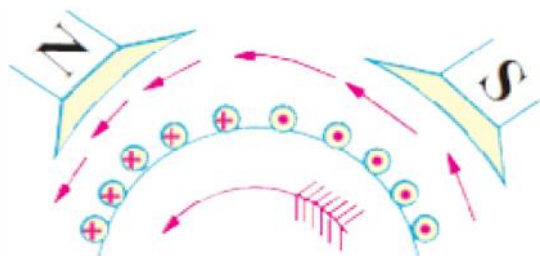

Figure 3.9: Part of multi-polar DC motor

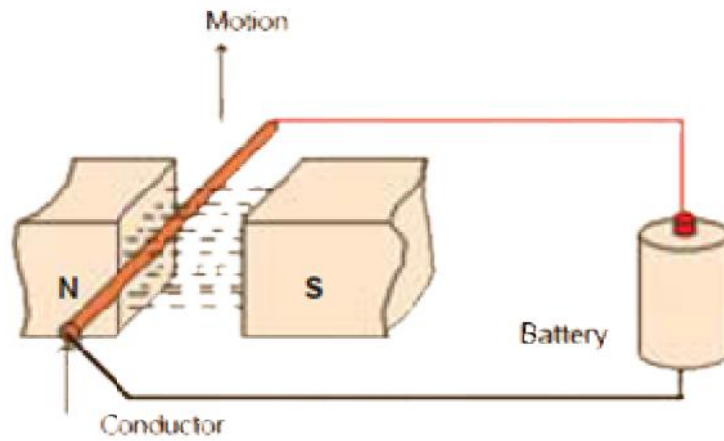

Figure 3.10: The motor principle

In this project we used a 12VDC motor located at the end of the circuit and it used simulate the PCP motor that used in petroleum well. In the circuit the input of motor is connected from the ULN 2802A IC.

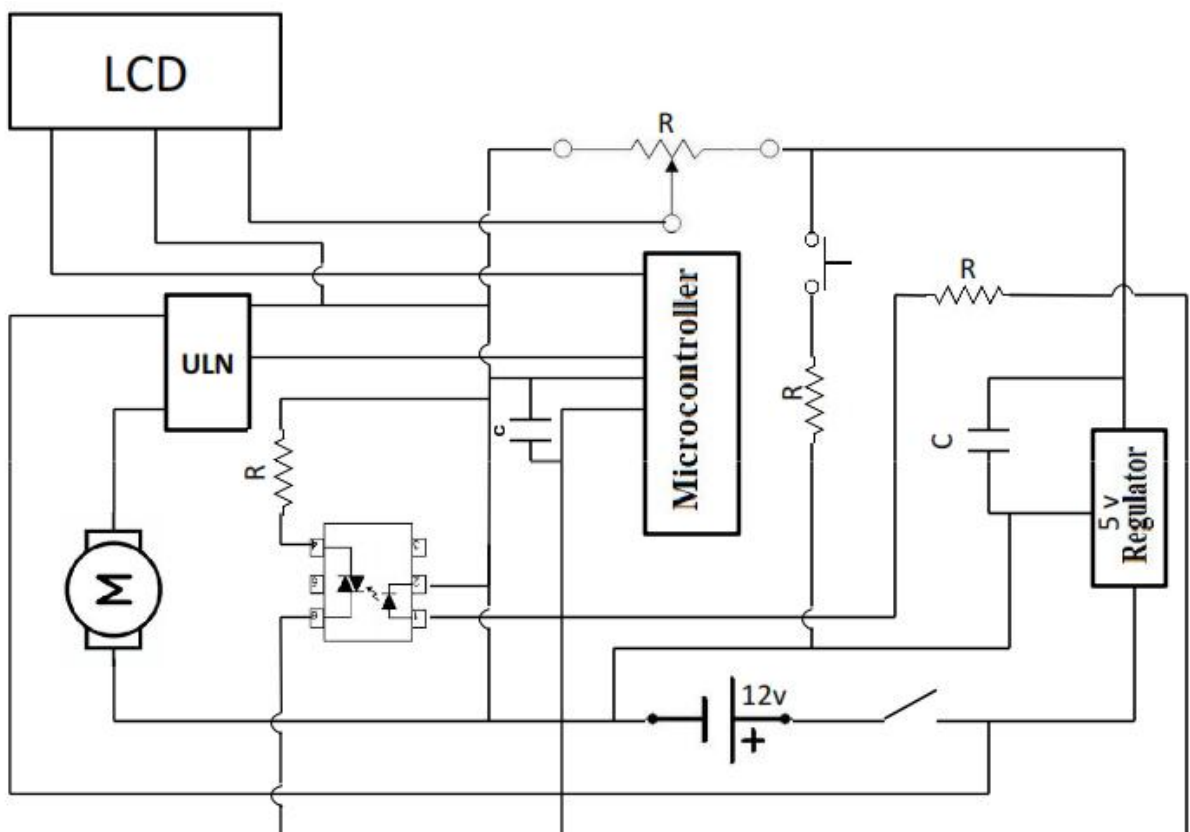

Figure 3.11: The simulation circuit block diagram

# CHAPTER FOUR

## CIRCUIT OPERATION

### 4.1 Real circuit

VSD and Smart Relay fed with the main power supply (415V-240VAC) as shown in (figure 4.1). Starting with Smart Relay we used a selector switch with the smart relay to start the auto restart control, selector switch connected with the smart relay in control point (I2). From port Q1 point 1 in smart relay connected to point 12 (Output 24VDC) in the VSD, and from the same port from point 2 connected to point 18 (Programmable digital inputs for controlling the drive) in VSD. Port Q2 used for the indication light. Point 13 (Output 24VDC) in VSD connected with point 27 (Digital Input) through a normal close switch to indicate service issue for a motor not operating or the drive not responding to a remote input. Point 4 and Point 5 in VSD connected to point (I1) in smart relay and the main power line respectively used for 30VAC, 42.5VDC, 1A relay output Can be used for indicating status and warnings.

In our circuit smart relay was used to operate the circuit by auto restart, when the blackout happen the smart relay activated automatically and sends the signal to VSD to start the motor after certain time according to a calculated time of the reverse rotation of the pump.

### 4.2 Simulation circuit

The operation circuit shown in (figure 4.2) start with the selector switch (which we used it as the main switch). The current flows from the power supply (12VDC) and enter the voltage regulator to regulate the volt amplitude to 5VDC, we connected a capacitor in parallel with the regulator to smoothen the voltage ripples.



The Regulator output (5VDC) feeds the microcontroller and the other devices that required 5VDC to operate such as LCD. The microcontroller was programmed to simulate the VSD and the Smart relay operation at once.

The microcontroller fed with 5volt in pin10 ( $V_{cc}$ ) and connected to the ground in pin11 (GND). There is a push button switch connected to pin38 (ADC2/PA2) in the microcontroller which used as starter of the microcontroller operation at the first press which start the movement of the motor. Then the second press simulates the blackout situation. After blackout happens in the real circuit the shaft will start rotating in reversal direction (because of the weight of the crude) but in the simulation circuit we couldn't simulate this motion because that we didn't find any heavy material can do the crudes work, so we programmed the microcontroller to simulate this motion by driving the motor at the same clockwise rotation but with less speed and it will start to reduces it speed until it reaches (0 RPM). The sensor send signal to microcontroller that the motor stopped rotating, and then the microcontroller will perform auto restart operation of the motor.

The LCD act as the primary monitor of our circuit. It connected to the microcontroller using the pins: (Rs,E,Db4,Db5,Db6 and Db7) which is connected to the microcontroller port B at pins (B0,B1,B4,B5,B6 and B7) respectively . 5volt fed the LCD in pin Vdd, also we connect 5 volt to a variable resister to adjust the contract of the LCD in pin Vo. The ground connected in pin Vss and  $\overline{R/W}$ .

The IR transmitter and receiver used to sense the rotation of the motor, IR transmitter connected to 5VDC supply throw static resistor to limit the current, and the other side connected directly to the ground. IR receiver connected directly to 5VDC source and the other side connected to the microcontroller directly to pin16 (int0), and to the ground through static resistor.

The ULN2802A connected to the ground in pin9, and fed with 12VDC in pin10 which will not pass through until the microcontroller sends a 5VDC signal to the ULN from pin19 (PD5) to pin2 at the ULN , and the output of the ULN from pin17 used as a ground for the DC motor which simulate the PCP pump .

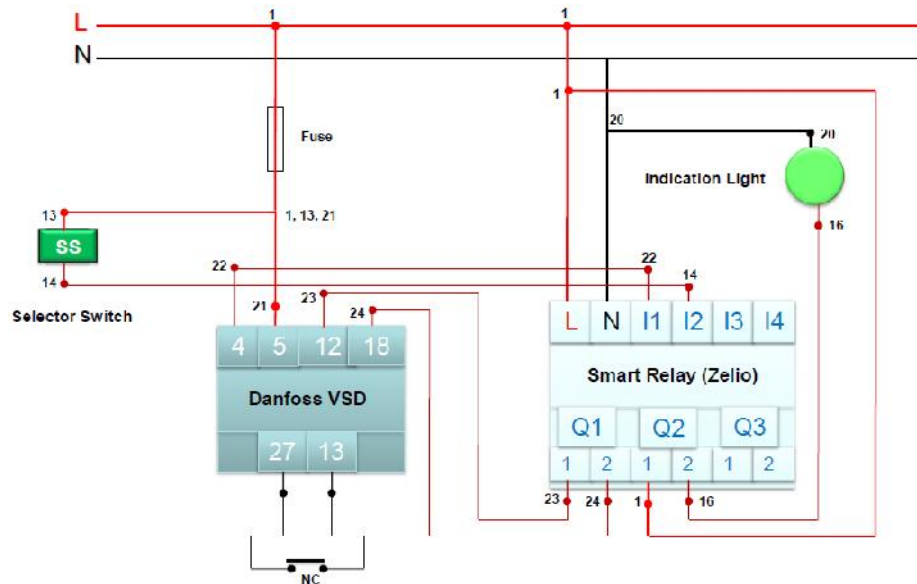

Figure 4.1: Shows the main VSD circuit connection

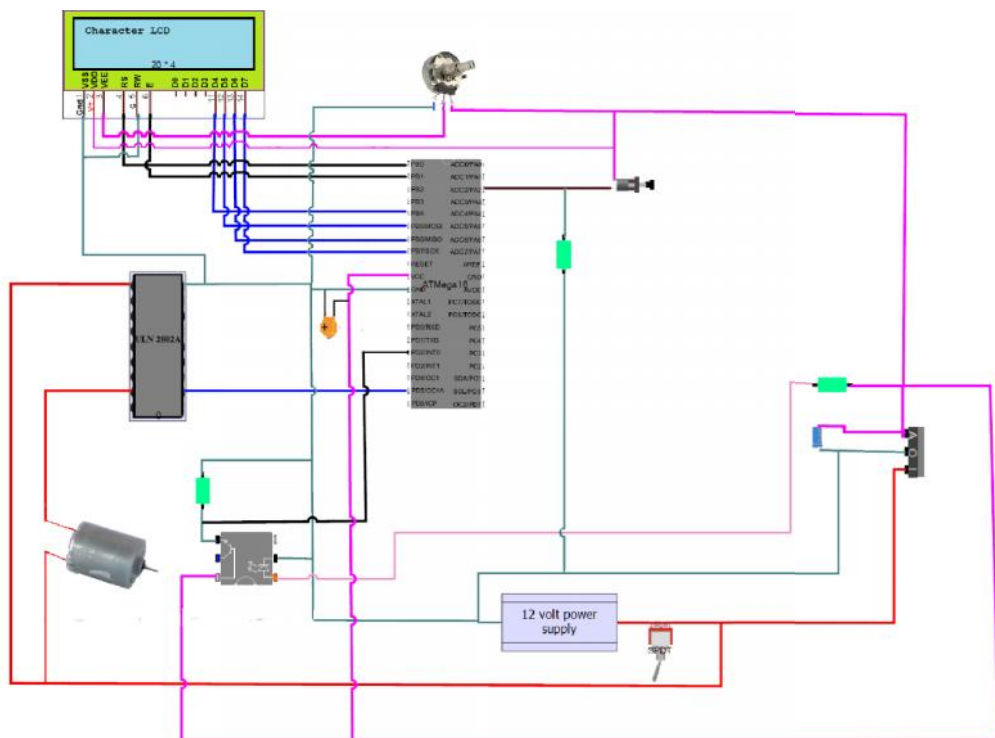

Figure 4.2: Circuit connection

Table 4.1: wires function dew their color

Wire Color	Wire function
Red	12 Volt
Green	Ground
Black &Blue	Microcontroller signal
Violet	Regulated 5 volt

# CHAPTER FIVE

## Conclusion and Recommendations

### 5.1 Conclusion

The real Auto Restart Circuit must be constructed with Variable Speed Drive , and Smart Relay , it was found so difficult to build due to their expensive cost, several companies and facilities in petroleum industry were given a visit to support this project but the search was ended with failure. That is why we chose to simulate the real circuit with microcontroller to do the Auto Restart Circuit job.

The simulation circuit was built. VSD and Smart Relay circuit simulated successfully using microcontroller and DC Motor with no errors in simulation.

### 5.2 Recommendations

After completing this project we suggest several recommendations that must be considered in the coming studies:

- ❖ We recommend applying the auto restart circuit using the main component (VSD and Smart Relay) practically.
- ❖ Replace the timer method with sensors as applied in microcontroller simulation circuit which is put us in front of several types of sensors to use not only the IR one.
- ❖ Replace auto restart circuit with Remote Terminal Unit (RTU).

# REFERENCES

- [1] Havard Devold,"Oil and gas production", ABB Oil and Gas, August 2013.
- [2] Joseph F.Hilyard , "The oil and gas industry", PennWell Corporation,2012 .
- [3] S.S.Rahman&G.V.Chilngarian,"Casing design theory and practice",Elsevier ,1995.
- [4] National plastic heater,"Relays", National Plastic Heater Sensor & Control Co.,[website [www.nphheaters.com](http://www.nphheaters.com)] .
- [5] Schneider Electric Industries SAS,"Smart relays Zelio Logic Catalogue".
- [6] Carrier Corporation , "Variable Frequency DRIVE" ,Carrier Corporation Syracuse, New York , 2005.
- [7] Malcolm Barnes,"Practical Variable Speed Drives and Power Electronics",IDC TECHNOLOGIES, 2003.
- [8] Schnier Electronic , "Zelio Logic Smart Relay User Manual",Schnier Electronic,2005.
- [9] Atmel,"Atmel atmega16 data sheet" , Atmel Corporation, 2003.
- [10] Analog Devices,"Understanding How a Voltage Regulator Works" , Analog Devices, Inc,2009.
- [11] STMicroelectronics , "Positive voltage regulators L78xx&L78xxC Datasheet",STMicroelectronics,2008.
- [12] SGS-THOMSON , " ULN 2082A Datasheet " , SGS-THOMSON Microelectronics ,1997.
- [13] Site:- techopedia - <https://www.techopedia.com/definition/8021/liquid-crystal-display-monitor-lcd-monitor> .
- [14] ROHM Semiconductor , "Optical sensors Data sheets", ROHM Semiconductor USA LLC, 2011.
- [15] Site:-<http://www.dummies.com/how-to/content/types-of-switches-in-electronic-circuits.html> .
- [16] F. Seymour MSEE , "BASIC ELECTRONIC COMPONENTS", Elenco™ Electronics, Inc,2004 .
- [17] B.L.Theraja& A.K.Theraja , "Electrical technology ",S.Chand & company LTD ,2005.

# APPENDIX A

## Microcontroller code

\$regfile = "m16def.dat"

\$crystal = 8000000

Config Pina.2 = Input 'sw

Config Lcd = 16 \* 2

Config Lcdpin = Pin , Db4 = Portb.4 , Db5 = Portb.5 , Db6 = Portb.6 , Db7 =  
Portb.7 , Rs = Portb.0 , E = Portb.1

Deflcdchar 0 , 16 , 24 , 28 , 31 , 31 , 28 , 24 , 16 'replace ? with number  
(0-7)

Config Timer1 = Pwm , Pwm = 8 , Compare A Pwm = Clear Down , Prescale  
= 1

Config Int0 = Falling

Enable Interrupts

Enable Int0

On Int0 Co

Pwm1a = 0

Dim X As Byte

Dim Y As Byte

Dim Z As Long

```
Cls
Cursor Off
Locate 1 , 1
Lcd " system start"

Wait 2

Cls

Do
Locate 1 , 1
Lcd " press sw to "
Locate 2 , 1
Lcd " start motor "
If Pina.2 = 1 Then Exit Do
Loop

First:
Cls
Wait 2

Do
Locate 1 , 1
Lcd " motor runing..."
If Y < 255 Then
Incr Y
Pwm1a = Y
End If
Gosub Monitor
```

Waitms 100

If Pina.2 = 1 Then

X = 1

Pwm1a = 0

Locate 1 , 1

Lcd " black out "

Wait 2

Pwm1a = Y

End If

While X = 1

Decr Y

Pwm1a = Y

Gosub Monitor

Incr Z

Waitms 200

If Z = 50 Then

Cls

Locate 1 , 1

Lcd "motor stopped"

Wait 3

Cls

X = 0

Z = 0

Y = 0



Gosub First

End If

Wend

Loop

Monitor:

If Y = 0 Then

Locate 2 , 1

Lcd " " "

Elseif Y > 0 And Y < 16 Then

Locate 2 , 1

Lcd Chr(0) ; " "

Elseif Y > 16 And Y < 32 Then

Locate 2 , 1

Lcd Chr(0) ; Chr(0) ; " "

Elseif Y > 32 And Y < 48 Then

Locate 2 , 1

Lcd Chr(0) ; Chr(0) ; Chr(0) ; " "

Elseif Y > 48 And Y < 64 Then

Locate 2 , 1

Lcd Chr(0) ; Chr(0) ; Chr(0) ; Chr(0) ; " "

Elseif Y > 64 And Y < 80 Then

Locate 2 , 1

Lcd Chr(0) ; Chr(0) ; Chr(0) ; Chr(0) ; Chr(0) ; " "

Elseif Y > 80 And Y < 96 Then

Locate 2 , 1

Lcd Chr(0) ; Chr(0) ; Chr(0) ; Chr(0) ; Chr(0) ; Chr(0) ; " "

Elseif Y > 96 And Y < 112 Then

Locate 2 , 1

```

Lcd Chr(0) ; Chr(0) ; Chr(0) ; Chr(0) ; Chr(0) ; Chr(0) ; Chr(0) ; "      "
Elseif Y > 112 And Y < 128 Then
Locate 2 , 1
Lcd Chr(0) ; Chr(0) ; Chr(0) ; Chr(0) ; Chr(0) ; Chr(0) ; Chr(0) ; Chr(0) ;
"      "
Elseif Y > 128 And Y < 144 Then
Locate 2 , 1
Lcd Chr(0) ; Chr(0) ; Chr(0) ; Chr(0) ; Chr(0) ; Chr(0) ; Chr(0) ; Chr(0) ;
Chr(0) ; "      "
Elseif Y > 144 And Y < 160 Then
Locate 2 , 1
Lcd Chr(0) ; Chr(0) ; Chr(0) ; Chr(0) ; Chr(0) ; Chr(0) ; Chr(0) ; Chr(0) ;
Chr(0) ; Chr(0) ; "      "
Elseif Y > 160 And Y < 176 Then
Locate 2 , 1
Lcd Chr(0) ; Chr(0) ; Chr(0) ; Chr(0) ; Chr(0) ; Chr(0) ; Chr(0) ; Chr(0) ;
Chr(0) ; Chr(0) ; Chr(0) ; "      "
Elseif Y > 176 And Y < 192 Then
Locate 2 , 1
Lcd Chr(0) ; Chr(0) ; Chr(0) ; Chr(0) ; Chr(0) ; Chr(0) ; Chr(0) ; Chr(0) ;
Chr(0) ; Chr(0) ; Chr(0) ; Chr(0) ; "      "
Elseif Y > 192 And Y < 208 Then
Locate 2 , 1
Lcd Chr(0) ; Chr(0) ; Chr(0) ; Chr(0) ; Chr(0) ; Chr(0) ; Chr(0) ; Chr(0) ;
Chr(0) ; Chr(0) ; Chr(0) ; Chr(0) ; Chr(0) ; "      "
Elseif Y > 208 And Y < 224 Then
Locate 2 , 1
Lcd Chr(0) ; Chr(0) ; Chr(0) ; Chr(0) ; Chr(0) ; Chr(0) ; Chr(0) ; Chr(0) ;
Chr(0) ; Chr(0) ; Chr(0) ; Chr(0) ; Chr(0) ; Chr(0) ; "      "

```

Elseif Y > 224 And Y < 240 Then

Locate 2 , 1

Lcd Chr(0) ; Chr(0) ; Chr(0) ; Chr(0) ; Chr(0) ; Chr(0) ; Chr(0) ; Chr(0) ;  
Chr(0) ; Chr(0) ; Chr(0) ; Chr(0) ; Chr(0) ; Chr(0) ; Chr(0) ; " "

Elseif Y > 240 And Y < 255 Then

Locate 2 , 1

Lcd Chr(0) ; Chr(0) ; Chr(0) ; Chr(0) ; Chr(0) ; Chr(0) ; Chr(0) ; Chr(0) ;  
Chr(0) ; Chr(0) ; Chr(0) ; Chr(0) ; Chr(0) ; Chr(0) ; Chr(0) ; Chr(0)

End If

Return

Co:

Z = 0

Return

# APPENDIX B

## The Simulation Circuit Module



Vertical view

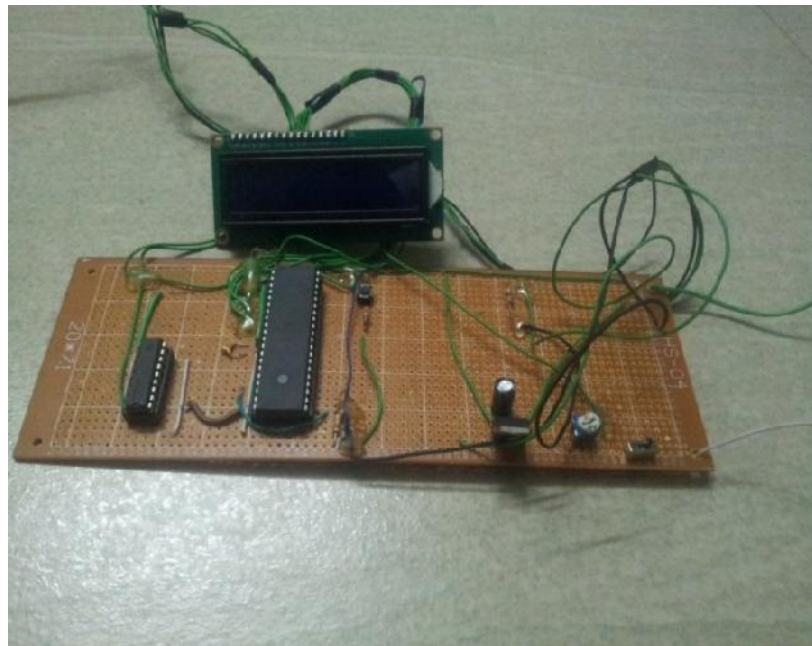

Horizontal view



The motor