



**SUDAN UNIVERSITY OF SCIENCE & TECHNOLOGY**  
**FACULTY OF COMPUTER SCIENCE & INFORMATION TECHNOLOGY**

**Data warehouse and Business intelligence**  
**(Sudanese electricity companies)**

مستودع البيانات والأعمال الذكية  
(شركات الكهرباء السودانية)

OCTOBER 2015

THESIS SUMMITTED AS A PARTIAL REQUIREMENTS OF B.Sc. (HONOR) DEGREE IN  
COMPUTER AND INFORMATION SYSTEM

بِسْمِ اللَّهِ الرَّحْمَنِ الرَّحِيمِ

SUDAN UNIVERSITY OF SCIENCE & TECHNOLOGY FACULTY OF  
COMPUTER SCIENCE & INFORMATION TECHNOLOGY  
DEPARTMENT OF COMPUTER AND INFORMATION SYSTEM

Data warehouse and Business intelligence

(Sudanese electricity companies)

مستودع البيانات والأعمال الذكية

(شركات الكهرباء السودانية)

THESIS SUMMITTED AS A PARTIAL REQUIREMENTS OF B.Sc. (HONOR) DEGREE IN  
COMPUTER SCIENCE

OCTOBER 2015

PREPARED BY

Ehsan Gareballah Mustafa

Safa Khalid Satti Ali Mahmod

Usra Mohamed Ahmed Alfaki

Supervisor:

AL Sharif Hago Almugadam Yusuf

بِسْمِ اللَّهِ الرَّحْمَنِ الرَّحِيمِ

﴿أَلَمْ تَرَ أَنَّ اللَّهَ أَنْزَلَ مِنَ السَّمَاءِ مَاءً فَأَخْرَجْنَا بِهِ ثَمَرَاتٍ مُخْتَلِفًا أَلْوَانُهَا وَمِنَ الْجِبَالِ جُدَدٌ بَيْضٌ وَحُمْرٌ مُخْتَلِفٌ أَلْوَانُهَا وَغَرَابِيبُ سُودٌ﴾ (٢٧) وَمِنَ النَّاسِ وَالْدَّوَابِّ وَالْأَنْعَامِ مُخْتَلِفٌ أَلْوَانُهُ كَذَلِكَ إِنَّمَا يَخْشَى اللَّهَ مِنْ عِبَادِهِ الْعُلَمَاءُ إِنَّ اللَّهَ عَزِيزٌ غَفُورٌ ﴿٢٨﴾ سورة فاطر.

## **Abstract**

The development of the business environment and technology in the world, The automation of systems which led to the accumulation of transaction data in the organizations and the need of information that enabling organizations to make tactical and strategy decisions that help them move forward to its goals, For that the need of business intelligence(BI) is came, BI help the organization in collection and integration the data from various sources and analysis it to help in extract information to help in decision-making.

Sudanese power companies that follow to the Ministry of Electricity and Dams lack of integration between their systems and these companies have appreciable amount of data generated by their systems and it need system to help in the analysis of this data to produce information help in decision-making.

The result of this study is provided BI system in accounting data that do integration between two companies from the electricity companies are Sudanese distribution electricity company (sedc) and the Sudanese thermal production company (stpc) to generate synthesis reports that help in decision-making by using the pentaho program, It is an open source program contains many build-in tools that help the developer to build business intelligence solution.

## المستخلص

أدى تطور بيئة الأعمال التجارية وغيرها في العالم وتطور التكنولوجيا وأتمتة الأنظمة لتراكم بيانات المعاملات في المؤسسات وأصبحت هنالك حاجة إلي توفر معلومات تمكن هذه المؤسسات من اتخاذ قرارات تكتيكية وإستراتيجية تساعدها في مواكبة بيئة الأعمال والمضي قدما نحو أهدافها من هنا جاءت الحاجة لذكاء الأعمال الذي يساعد المؤسسات في تجميع بياناتها من مختلف المصادر وتحليلها لإستخراج معلومات تساعدها في اتخاذ القرارات .

شركات الكهرباء السودانية التي تتبع لوزارة الكهرباء والسدود تفتقر للتكامل بين أنظمتها وكذلك هذه الشركات تمتلك كمية مقدره من البيانات الناتجة من أنظمتها وتحتاج وزارة الكهرباء والسدود لنظام يساعدها في دمج البيانات الناتجة من أنظمة الشركات وتحليلها لإنتاج معلومات تساعدها في اتخاذ القرارات .

النتائج التي توصلت لها هذه الدراسة نظام ذكاء أعمال يعمل علي البيانات الحسابية للشركة السودانية لتوزيع الكهرباء المحدودة (sedc) والشركة السودانية للتوليد الحراري المحدودة (stpc) يساعدها في استخراج تقارير تجميعية تساعدها في اتخاذ القرار وذلك باستخدام برامج pentaho وهو عبارة عن برنامج مفتوح المصدر يحتوي علي العديد من الأدوات التي تساعد المطور في بناء حل للأعمال الذكية .

## **Dedication**

To our dear mothers, you are provided us the guidance we needed throughout our life, things just seem to get a little more complicated the older we get. Thanks for all your support, you're always near a tender smile to guide us way you're the sunshine to light our life.

To our dear fathers Thanks for being there when we need you the most and even when we didn't. To all our family's members whom were source of success, by giving us the confidence.

## **Acknowledgements**

We thank Almighty God for giving us the courage and the determination, As well as guidance us in conducting this research study, Despite all difficulties.

We would like to express our gratitude to our Supervisor AL Sharif Hago Almagadam Yusuf and everyone how supply us from Nile center for technical research and from Sudanese electricity companies.

Finally, thanks to all our friends who endured this long process with us and always offered support.

# Table of Figures

Figure (2. 1)Components of Business Intelligence system .....	6
Figure (2. 2) Star schema of data warehouse.....	8
Figure (2. 3) Snowflake schema of data warehouse.....	9
Figure (2. 4) Fact constellations of data warehouse.....	9
Figure (2. 5) Application of Business Intelligence in Manufacturing .....	14
Figure (3. 6) Pentaho BI stack.....	18
Figure (3. 7) Use Case Diagram for the system .....	21
Figure (3. 8) Sequence Diagram for login user .....	22
Figure (3. 9) Sequence Diagram view report for user.....	23
Figure (3. 10) Sequence Diagram login system for administator .....	24
Figure (3. 11) Sequence Diagram connection to data source for administrator.....	25
Figure (3. 12) Sequence Diagram authorization for administrator .....	26
Figure (3. 13) Sequence Diagram view report for administrator .....	27
Figure (3. 14) Activity Diagram for System.....	28
Figure (4. 15) Pentaho login page.....	30
Figure (4 .16) Pentaho administrator console .....	31
Figure (4. 17) Pentaho non administrator console.....	32
Figure (4. 18) Browse file page.....	33
Figure (4. 19) Manage data source.....	34
Figure (4. 20) Database as data source connection.....	35
Figure (4. 21) Succeeded message .....	35
Figure (4. 22) User role .....	36
Figure (4. 23) Control mail server .....	36
Figure (2. 25) Control thr report duration and schedule .....	37
Figure (4. 26) Schedule page .....	38
Figure (4. 27) Comparison between the current system and the proposed system .....	39



# Table of Content

Abstract.....	iv
المستخلص.....	v
Dedication.....	vi
Acknowledgements.....	vii
Table of Figures.....	viii
CHAPTER 1.....	1
INTRODUCTION.....	1
1.1 Introduction:.....	2
1.2 Problem Statement:.....	2
1.3 Objectives:.....	2
1.4 Scope:.....	3
1.5 Thesis Layout:.....	3
CHAPTER 2.....	4
BACKGROUND TO BUSSINESS INTELEGANCE AND PREVIOUS STUDIES.....	4
2.1 Introduction:.....	5
2.2 Business intelligence (BI) Definition:.....	5
2.3 Business intelligence (BI) overview:.....	5
2.4 The Key Components of Business Intelligence system:.....	6
2.4.1 Data sources:.....	6
2.4.2 Data warehouse and data mart:.....	6
2.4.3 ETL:.....	9
2.4.4 OLAP (On line Analytical Processing):.....	10
2.4.5 Data mining:.....	10
2.4.6 Dashboard:.....	10
2.5 Business intelligence applications:.....	11
2.6 open source Business intelligence applications:.....	11
2.6 Related Studies:.....	11
CHAPTER 3.....	16
WORK ENVIROMENT AND PROPOSED SYSTEM ANALYSIS.....	16

3.1 Introduction:	17
3.2 System Requirement specification:	17
3.3 Techniques used in the system:	17
3.3.1 Pentaho tool:	17
3.3.2 Release of pentaho:	17
3.3.3 Pentaho BI stack:	18
3.3.4 The Pentaho BA Suite divided into two parts:	19
3.4 UML technology:	20
3.5 System Analysis:	21
3.5.1 Use Case Diagram:	21
3.5.2 Sequence Diagram:	22
3.5.3 Activity Diagram:	28
CHAPTER 4	29
RESULTS AND DISCUSSION	29
4.1 Introduction:	30
4.2 system implementation:	30
4.3 The Result:	39
CHAPTER 5	40
CONCLUSION AND RECOMMENDATIONS	40
5.1 Conclusion:	41
5.2 Recommendations:	41
References:	42
Appendix A:	43
Table (A.1) comparison between pentaho and other open source tool	43



**CHAPTER 1**  
**INTRODUCTION**

# 1.1 Introduction:

The concept of integration and business intelligent (BI) is important in the institutions, Organizations and ministries systems, Because it helps at provide public vision and Work status to the Top official and help to reduce the time spent on the decision-making process and makes the work done in complete coordination.

There are several companies in Sudan provide electricity service follow to the Ministry of Electricity and Dams, Namely: (Sudanese Electricity Distribution Company, Sudanese company to generate water, Sudanese company for thermal generation, Sudanese Transport Company, Merowe Dam) Systems of these companies operate in Enterprise Resource Planning system(ERP), Which is openerp and the final reports are separated from each other and filed by each company alone to the Ministry of Electricity and Dams, Hence the need for integration process.

# 1.2 Problem Statement:

The problems of this thesis are as follows:

Firstly the lack of integration between power companies, since each company generate reports by its own openerp system and directed it to the Ministry of Electricity and Dams, And each report only describes the case of the generator system from it, Secondly the Ministry of Electricity and Dams facing difficult see the common work status between these companies, Finally companies existing system does not provide reports that contain information help in decision make.

# 1.3 Objectives:

The objectives of this Research are as follows:

- Generate of aggregation reports from different power companies, And to have knowledge from historical data store for a long period of time to help in the decision-making process.
- Generate reports to help the Ministry of Electricity to know the status of joint work between the companies and the creation of general consistency between these companies.

## **1.4 Scope:**

For ministry of Electricity and Dams this Research provides ability to produce reports from data of the Sudanese electricity distribution company (sedc) and the Sudanese thermal production company (stpc) and this Research project will work in the accounting data from the two companies previously mentioned to generate accounting reports.

## **1.5 Thesis Layout:**

Chapter one gives introduction about the project, Defining the problem, Objectives, and scope. Chapter two contains two parts, Part one represents a general background about business intelligence, Part two is the related studies and business intelligence application, Chapter three also contains two parts, first part explains the tools and techniques used in this project, and the second part is the UML design for the project functionality, Chapter four contains the project implementation, Chapter five is the results and recommendations.

## **CHAPTER 2**

# **BACKGROUND TO BUSSINESS INTELEGANCE AND PREVIOUS STUDIES**

## 2.1 Introduction:

This chapter is divided into two sections, the first section gives general description of business intelligence and its technique, the second section describes the related studies to research project.

## 2.2 Business intelligence (BI) Definition:

Business Intelligence often referred to as BI, Is a term to name the efforts to convert all transactional data generated by daily activities of the organization into valuable and timely information to make correct decisions, To measure the performance of this organization in specific indicators inside this organization or to benchmark that organization determining it in its goal.<sup>[1]</sup>

Hans Peter Luhn provide first definition of BI in his article "A Business Intelligence System", Published in the October 1958 IBM Journal he define BI as "The ability to apprehend the interrelationships of presented facts in such a way as to guide action towards a desired goal".<sup>[2]</sup>

In 1989, Gardner analyst Howard Dresner employed the term "business intelligence" as a general term used to cover the names used in the data storage and data analysis, Such as the names of DSS and executive information systems (EIS).<sup>[3]</sup>

More recently in 2007 Business intelligence defined as "having the right access to the right data or information needed to make the right business decisions at the right time" in A book titled 'Oracle Data Warehousing and Business Intelligence Solutions'.<sup>[4]</sup>

## 2.3 Business intelligence (BI) overview:

Today's companies regardless of size or industry need to keep up with the changing in business Nature, They also need to cut costs, Remain competitive, And find new business opportunities in the current economic climate, also companies today have access to more data than ever, But the collection and analysis of that data and turn it into useful information is a big challenge. Business Intelligence can be an effective way to do this, Business Intelligence can help decision-makers to get access to the data they need so that they can adapt quickly to changing circumstances and identify new opportunities.<sup>[3]</sup>



## 2.4 The Key Components of Business Intelligence system:

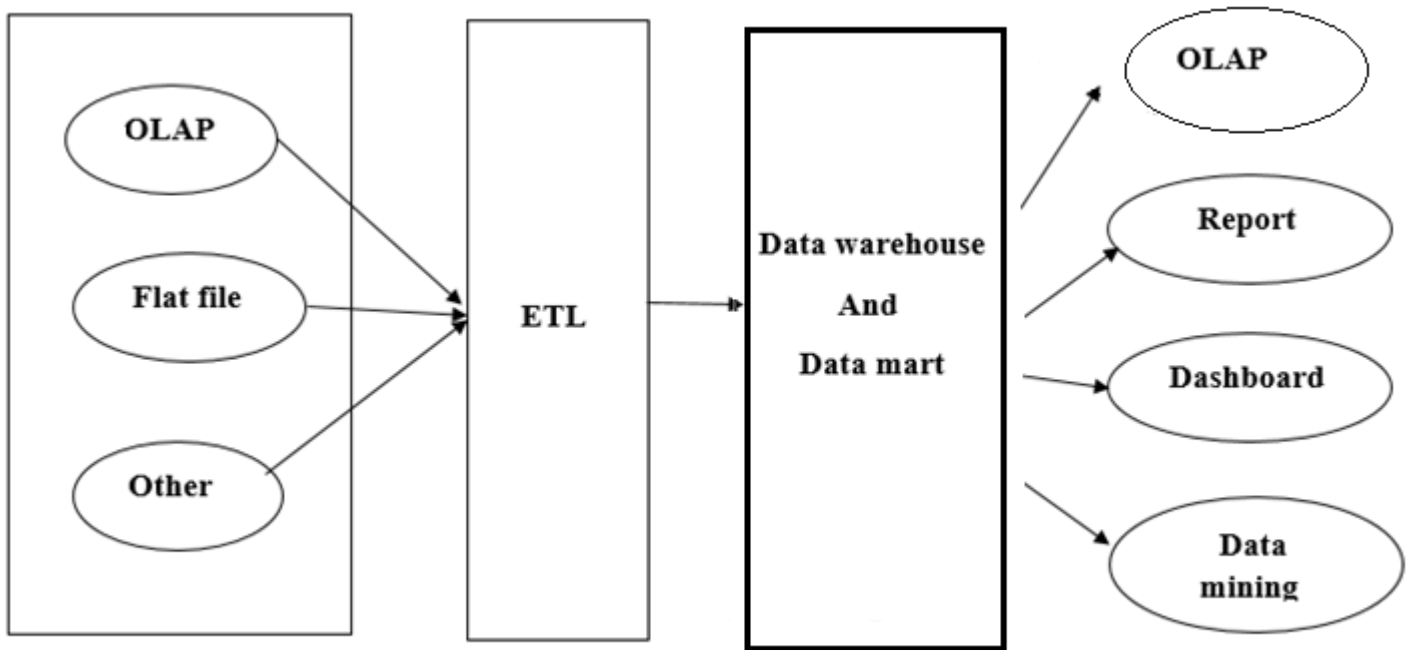

Figure (2. 1)Components of Business Intelligence system

### 2.4.1 Data sources:

Can be operational databases of OLTP system, Flat file, Historical data on archive and other, Data sources can be on many different platforms and can be in structured format, Such as tables or spreadsheets, Or unstructured format, Such as plaintext files or pictures and other multimedia.

### 2.4.2 Data warehouse and data mart:

#### 2.4.2.1 Data Warehouses Definition

Bill Inmon in 1990 develops the modern concept of Data warehouses; He said that Data warehouse is subject Oriented, Integrated, Time-Variant and nonvolatile collection of data. This data helps in supporting decision making process by analyst in an organization. Dependence on definition the characteristics of the data warehouse are:

- **Subject Oriented:** Data collection and organization are in accordance with the topics that affect the activity of the organization and not accordance with the ongoing operations, Such as data

about customers, Products, ETL mean focus is on modeling and analyzing the data necessary to make decisions.

- **Integrated:** Data were collected from different source, Therefore must be integration and cohesion to give Unified meaning, Understand for user.
- **Non Volatile:** Non-adjustable when you load the data in the warehouse it used only for analysis, Study and display.
- **Time-Variant:** means that any changes in the data should be recorded to reflect the resulting reports those changes to have occurred in previous periods.<sup>[5]</sup>

### 2.4.2.2 Data mart:

Data mart an integral part of the data warehouses, where the stores are divided into a set of specialized stores, such as financial management, and other special human resources management or division be based on the branches of Enterprise. The cause of division is to helps focus and precision of What is the knowledge that will be discovered as well as to reduce efforts, The creation of data marts allows the split of data which helps in the process accessible, To speed up queries by reducing the scanning process of the data, Also allow setting any data mart in different hardware platforms and To organize the data in a form suitable for user access. Before build data mart the data mart strategy must be appropriate for the particular solution and taking into consideration the cost of hardware, software, Network and Access Time.<sup>[5]</sup>

### 2.4.2.3 Terminology in data warehouse:

**Fact table:** In data warehousing, The Fact table consists of the measure or facts of a business process, It is placed in the center of a star schema or a snowflake schema and dimension tables around it.

**dimension table:** is a table that linked to a fact table, The fact table contains business facts (or measures), and foreign keys which refer to primary keys in the dimension tables, Dimension tables contain descriptive attributes (or fields) these attributes do two purposes: to apply query constraining and filtering resulted data.

### 2.4.2.4 Why Data Warehouse Separated from Operational Databases:

A data warehouse is type of database that contains tables, Indexes, Queries and other but the fundamental difference:

**Firstly-In terms of design:** - databases are designed to store and organize operational data, While Data warehouses are designed to store and analyze the collection of data from different source and reorganized it to allow for analyzing and extracting important information from them to help in decision-making, Also use the data warehouses to store huge amounts of data for periods long.

**Secondly-In terms of purpose:** -The usual databases used in the daily operations of the input, Modify, And delete immediate and query, While data warehouse do not use to usual daily operations, But the goal of it is to implement long-analytical queries, And extraction of complex reports in order to facilitate decision-making in enterprises, Therefore data warehouse is only to read. [6]

### 2.4.2.5 Schema of data warehouse:

The schema is a logical description of the entire data warehouse, The schema includes the name and description of records of all record types including all associated data-items and aggregates, Likewise the data warehouse requires the schema, The data warehouse uses the Stars, snowflake and fact constellation schema. [5]

- **Star schema:** A fact table in the middle connected to a set of dimension tables.

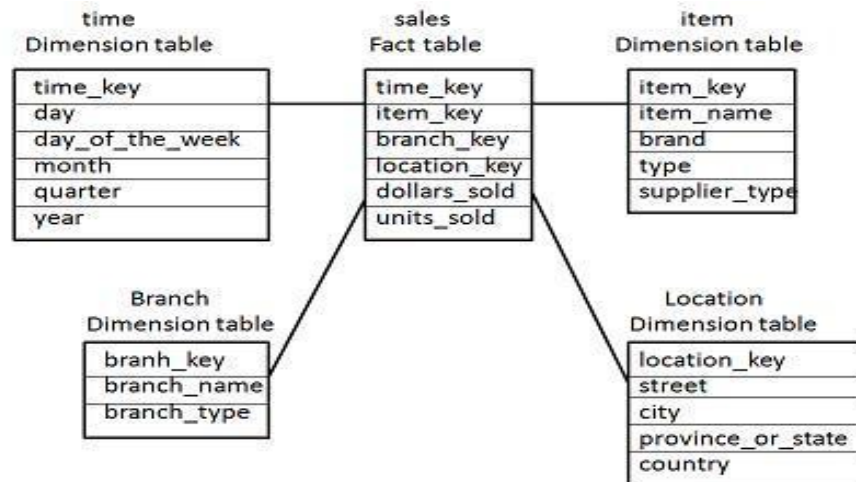

Figure (2. 2) Star schema of data warehouse

- **Snowflake schema:** an extension of the star schema where some dimensional hierarchy is normalized into a set of smaller dimension tables, Forming a shape similar to snowflake.

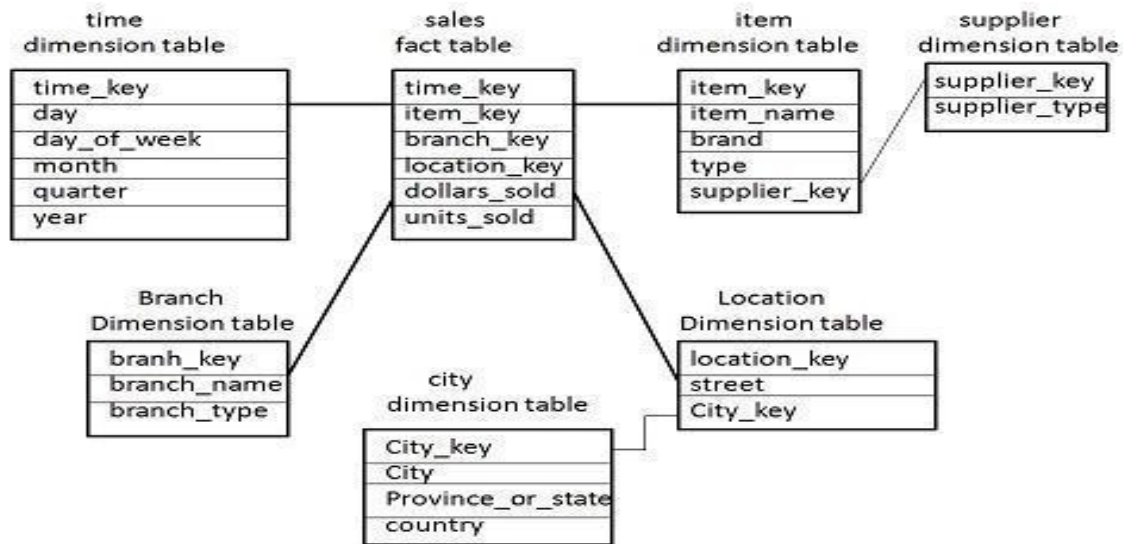

Figure (2. 3) Snowflake schema of data warehouse

- **Fact constellations:** Multiple fact tables share dimension tables, Viewed as a collection of stars, Therefore called galaxy schema or fact constellation.

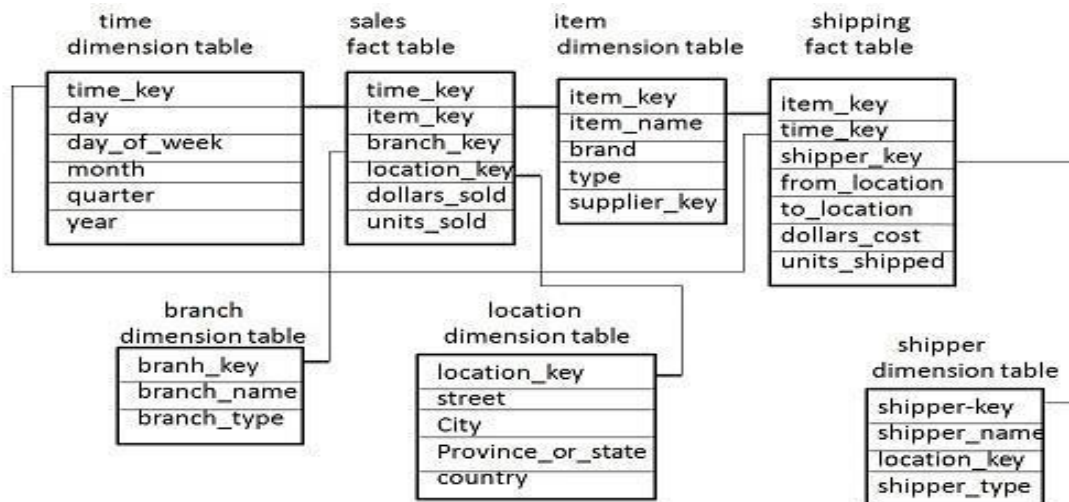

Figure (2. 4) Fact constellations of data warehouse

## 2.4.3 ETL:

ETL (Extract, Transform, and Load) refer to process use to filling a data warehouse and data mart

- **Extraction** is acquiring data from one or more source systems.

- **Transformation** is changing the format and/or content of the data to fit it into the structure of the target data warehouse or data mart another operation is data cleaning: data cleaning involves finding and correcting the errors in data.
- **Loading** is actually storing data in the target data warehouse or data mart.<sup>[7]</sup>

## 2.4.4 OLAP (On line Analytical Processing):

It aims to extract knowledge from a data warehouse or data marts, Its main idea is providing navigation through data to non-expert users, So that they are able to interactively generate ad-hoc queries without the intervention of IT professionals, The OLAP is based on the multidimensional view of data (Looking at data in several dimensions), And the OLAP operations:-

- **ROLL-UP, DRILL-DOWN operation:** ROLL-UP and DRILL-DOWN is Opposite operations Where the tow operation performs aggregation on a data cube the ROLL-UP process do By climbing up and concept of hierarchy for a dimension and dimension reduction, But the drilling down By stepping down a concept hierarchy for a dimension, And the introduction of a new dimension.
- **SLICE, DICE operations:** SLICE and DICE operations gives us a new sub cube The slice operation performs selection of one dimension but The Dice operation performs selection of two or more dimension.
- **PIVOT:** The pivot operation is also known as rotation, It rotates the data axes in view in order to provide an alternative presentation of data.

## 2.4.5 Data mining:

Data mining is process of analysis accurate and intelligent, Such as association, Clustering, Classification, Prediction can be integrated with OLAP operations to enhance managers of activities when using this process to make decisions, Analysis of a large amount of data considered in order to create rules and examples and models that can lead decision-makers, To show the predicted future behavior.

## 2.4.6 Dashboard:

Dashboard is outputs of the leading business intelligence applications at this time, Is defined as user interface, Graphical presentation often single page, Making it easy to read and give a view of the

current situation of the organization and historical trends for the organization or the computers of key performance indicators to enable to give immediate decisions and informed choices.

## **2.5 Business intelligence applications:**

Business Intelligence applications is a kind of software designed to retrieve, Analyze, Convert and report the data that have already stored and provide information on the Business Intelligence system business intelligence applications can be standalone tools or suites of tools.

## **2.6 open source Business intelligence applications:**

Open Source Business Intelligence applications are capable tools to build BI system, Most of Open Source Business Intelligence applications (OSBI apps) can be used promptly by developers with no licensing costs.

OSBI applications have friendly graphics users interfaces for developers, Aimed to standardize and make little more easy developers' work, a developer easily can do a wide range of work including, JDBC connectivity, ETL process, Access virtually all databases and data repositories, And easy data integration processes development.

OSBI applications requires less hardware and software resources than it commercial counterparts, also OSBI tools support can be obtained commercially from OSBI big players: Pentaho, Jaspersoft, SpagoBI<sup>[8]</sup>.

## **2.6 Related Studies:**

- **Pentaho helps the Rio Negro Province to recover money and prepare for the future ( 2014, Pentaho)<sup>[9]</sup>**

The purpose of this study to know the problems that faced ARTRN Company and how they overcame it using pentaho.ARTRN's problems was to create a set of management reports that were flexible, Friendly, Easy to interpret and accessible for users in real time, And also ARTRN needed to provide the user ad-hoc analysis of information, As well as to provide static reporting, ARTRN company solve this problems with Pentaho Data Integration for loading, Updating and orchestration

the creation of a new Data Warehouse and Pentaho Business Analytics to allow users to easily visualize their data and analyze key trends.

- **WebAssign Uses Business Analytics to Improve Education (2015, Pentaho).**<sup>[10]</sup>

WebAssign distributes educational materials to more than 600,000 students worldwide each semester, The amount of data generated exceeded the capabilities of their legacy data analysis tool, For each new report that executives wanted to run, WebAssign needed a developer to write custom code, which resulted in a backlog of IT requests and severely limited the types of data reports that could be created. In addition, data was spread across various databases, spreadsheets, Google documents, and customized code in the WebAssign web application, Complicating efforts to compile and analyze the data. As a result, WebAssign executives lacked insight into critical information, Such as which textbooks were most popular and by how much, WebAssign needed a business analytics solution to automate the collection of disparate data across the organization and provide real-time data analysis, By implementing the Pentaho Business Analytics platform, Centralizing company data and making data analysis accessible to users across the company, WebAssign has achieved unprecedented visibility into its finances and business operations, Customized Pentaho dashboards allow users to visualize data in different ways through histograms and graphs. In a glance, WebAssign executives can see statistics on usage and student performance, Enabling them to improve operations, control expenditures and help students to learn more efficiently.

- **Metro Bank Building a bank that can surprise and delight with Power BI**<sup>[11]</sup>

The vision of Metro Bank is to redefine the relationship people have with their bank by innovating customer service, To go for word to this vision Metro Bank decided to implement Microsoft Power BI because the solution integrated easily with the bank's existing Microsoft stack, And was easy for its employee to quickly learn for their daily needs, Metro Bank use Microsoft Power BI in different services and areas (Call center operations, Mobile and Internet banking, Customer dissatisfaction reports and Staffing and workload planning).

- **The Study on the Application of Business Intelligence in Manufacturing (2013 International Journal of Computer Science Issues).**<sup>[12]</sup>

This study reviews the application of the BI in various areas of the manufacturing, This study included a group of cases that the BI helped it to overcoming the problems, particularly with regard to the extraction of information from the data, Without having enough information and visualization, Is a waste of time for the management and staff in the development of future plans and progress in running processes easily, As well as the delay on the time delivery performance, high production costs and poor production plans, This paper proves the importance of the BI and not to ignore it nowadays, If we have a lot of data but could not answer the question of what is important in the data, An elaboration of the previous studies related to the application of BI in manufacturing organizations in the operation or production site shows in the following table, In this Table nine paper works from different manufacturing sectors was analyzed, The classification is done according to the manufacturing sector, problems, BI solution for the problems and the results obtained from the BI tools applied.

Researcher	Manufacturing Sector	Area in Organization	Problems	BI Solution	Results
A.L. Azevedo and J.P. Sousa, 2000	Semiconductor	Production and Operation	<ul style="list-style-type: none"> <li>• Order prioritization is only by date</li> <li>• Unlimited capacity assumption</li> <li>• Time-consuming plan regeneration</li> </ul>	<ul style="list-style-type: none"> <li>• Decision Support System – Business Systems and Manufacturing Execution Systems integration</li> </ul>	<ul style="list-style-type: none"> <li>• Customer orders management in real-time in a distributed environment.</li> <li>• Delivery dates are determined based on capacity check, thus improve the due date calculation efficiency, precision and reliability.</li> </ul>
Russell Barr, Fayyaz Hussain and James Sommers, 2005	Cement	Operation & Finance	<ul style="list-style-type: none"> <li>• Information is shared by e-mail with excel spreadsheet attached leads to data inconsistency</li> <li>• E-mail sent is from different time frames</li> </ul>	<ul style="list-style-type: none"> <li>• Real-time Performance Dashboard</li> </ul>	<ul style="list-style-type: none"> <li>• 3% reduction in operation costs.</li> <li>• 5% increase in production</li> </ul>
Gang Xiong, Timo R. Nyberg and Feiyue Wang, 2010	Chemical	Production & Global	<ul style="list-style-type: none"> <li>• No common visibility among departments – inconsistent decision making</li> <li>• Low production output due to no real-time response ability to manufacturing disruptions and demand changes</li> <li>• High maintenance cause due to no real-time between production plan and execution</li> </ul>	<ul style="list-style-type: none"> <li>• XMII (Manufacturing Integration and Intelligence)</li> </ul>	<ul style="list-style-type: none"> <li>• 3% - 5% reduction in manufacturing costs</li> <li>• 8% - 10% increase in production yield</li> <li>• Increase customer responsiveness</li> </ul>



<p>Juhani Heilala, Matti Maantila, Jari Montonen, Jarkko Sillanpaa, Paula Jarvinen, Tero Jokinen and Sauli Kivikunnas, 2010</p>	<p>Faucet</p>	<p>Production</p>	<ul style="list-style-type: none"> <li>• Manufacturing simulation data is updated only once or very rare</li> <li>• Simulation analysis produces many tables, lists and reports – difficult and time consuming for decision makers to locate the information</li> </ul>	<ul style="list-style-type: none"> <li>• Simulation-based Decision Support System focusing on visualization.</li> </ul>	<ul style="list-style-type: none"> <li>• Capable to see the potential bottlenecks or other production problems to take corrective actions</li> <li>• Pro active planning and problem solving for production</li> <li>• Benefit for production operators: Early information for upcoming work</li> <li>• Benefit for production engineers: Planning changes or new systems</li> </ul>
<p>Anil B. Jambekar and Karol I. Pelc, 2006</p>	<p>Electronics Measuring Instruments</p>	<p>Production, Finance, Competitors and Customers</p>	<ul style="list-style-type: none"> <li>• No monitoring systems to adapt to industrial operational condition.</li> <li>• No preparation for managers for potential increased production sale.</li> <li>• Serious needs to increase sales and expand business.</li> </ul>	<ul style="list-style-type: none"> <li>• Managerial Dashboard</li> </ul>	<ul style="list-style-type: none"> <li>• Ability to monitor the firm's operation performance</li> <li>• Managers benefit it by able to identify technical and managerial knowledge to prepare for a large scale manufacturing</li> </ul>
<p>G R Gangadharan and Sundaravalli N Swami, 2004</p>	<p>Electrical and Electronics Components</p>	<p>Production, Store and Sales</p>	<ul style="list-style-type: none"> <li>• Difficulty to forecast sales, production and distribution</li> <li>• Poor service and high inventory level</li> <li>• Reporting systems are hard to use, inflexible and outdated</li> </ul>	<ul style="list-style-type: none"> <li>• Data Mart, Data Tracker, Reporting and Web Integration</li> </ul>	<ul style="list-style-type: none"> <li>• Boosted up the company's revenue by 36%</li> <li>• Information that used to take hours or days to report is available instantaneously – in sales, forecasting, production, planning, order tracking, profit analysis and ad-hoc reporting</li> </ul>

Figure (2. 5) Application of Business Intelligence in Manufacturing

- **Summary of previous studies:**

According to the studies above, Business intelligence help companies that apply it to take effective decisions and provide insight into the Executive manager about company and business trends, also reduce the time and effort that was carried out by companies in the previous to production reports to help in decisions making and we find that the Business Intelligence application is not confined to a particular area, Business Intelligence enabled companies to follow best work processes that reduce the cost and increase the productivity, Through the business Intelligence provided information to help in make better Business decisions and helping companies move towards strategic objectives.

## **CHAPTER 3**

# **WORK ENVIROMENT AND PROPOSED SYSTEM ANALYSIS**

## 3.1 Introduction:

This chapter describes specification of devices, operating system, work environment, and techniques used to build the system, and then describe the system analysis using UML technology.

## 3.2 System Requirement specification:

Ubuntu : 14.04

Installed java JDK 7

Installed java JRE 7

CPU performance “GHz” 2.99

Number of cores 3

RAM “GB” 2 at least

Disk space “GB” 250 at minimum

## 3.3 Techniques used in the system:

### 3.3.1 Pentaho tool:

In 2004 Pentaho were arise to offer complete BI suites that the existing stand-alone BI solutions ,<sup>[7]</sup> Pentaho tool is comprehensive platform enables you to access, Integrate, Manipulate, Visualize, And analyze your data, Whether stored data in a flat file, Relational databases, Hadoop , Analytic database, social media streams, Operational stores, Or in the cloud , The Pentaho BA Suite help to discover, Analyze and visualize data to reach for answers that we need and do not require programming experience because developer can customize the reports, Queries and transformations, Or extend the functionality using the extensive API to ours.<sup>[13]</sup>

### 3.3.2 Release of pentaho:

The Pentaho suite consists of two offerings, An enterprise and community edition, The enterprise edition contains features not found in the community edition, Require subscription annually

The enhancements, Service, and support packaged with the BI Suite Enterprise Edition are designed to accommodate production environments, Especially where downtime and time spent figuring out how to install, Configure, And maintain a business intelligence solution are prohibitively expensive, As a Pentaho BI Suite Community Edition user, You will have to install, Configure, And maintain the software on your own, Your only support options are the community forum. [7]

### 3.3.3 Pentaho BI stack:

Pentaho is a business intelligence suite rather than a single product: it is made up of a collection of computer programs that work together to create and deliver business intelligence solutions. Some of these components provide functionalities that are very basic, Such as user authentication or database connection management, Other components deliver functionality that operates at a higher level, Such as visualizing data using charts and graphs. [7]

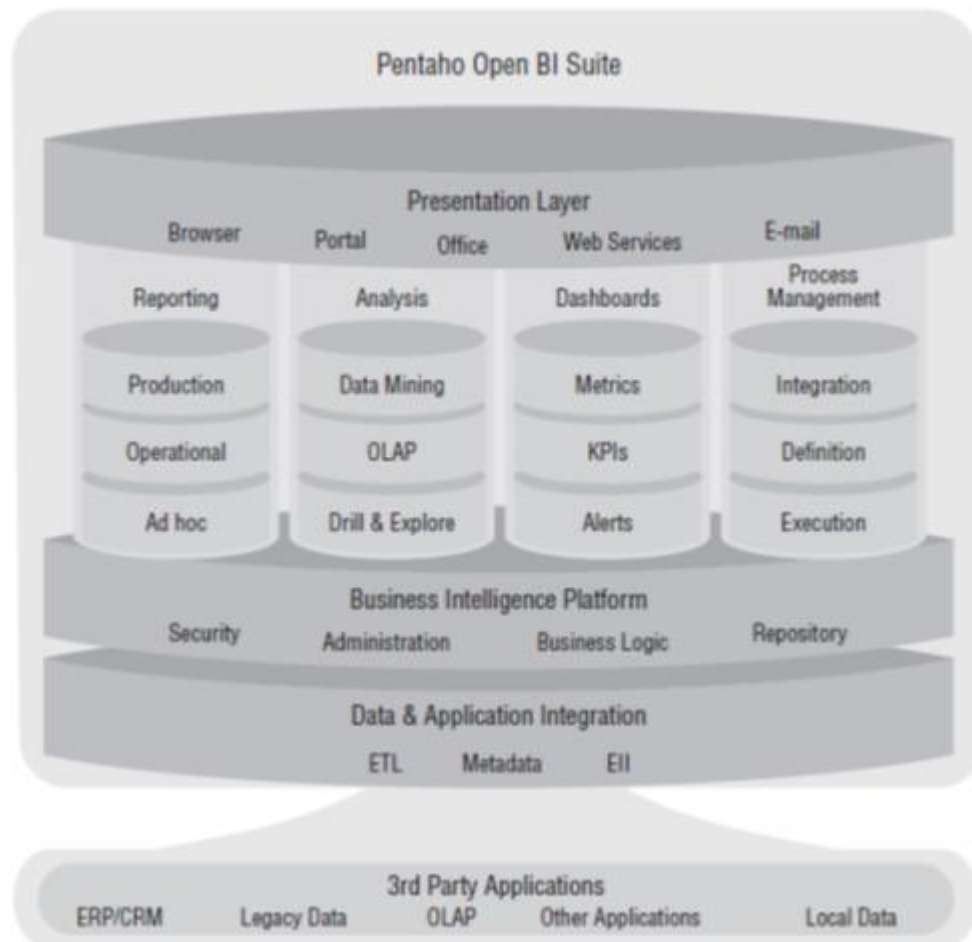

Figure (3. 6) Pentaho BI stack

In Figure 4-1, the main layers of the stack are clearly identified, with the presentation layer at the top and the data and application integration layer at the bottom. Most end users will interact with the presentation layer, The main functional areas of the BI stack are Reporting, Analysis, Dashboards, And process management constitute the middle layer of the stack, Whereas the BI platform itself delivers basic features for security and administration, Data integration completes the stack and is needed to get data from various Source systems into a shared data warehouse environment. <sup>[7]</sup>

### **3.3.4 The Pentaho BA Suite divided into two parts:**

#### **3.3.4.1 Business Analytics:**

Set of components that are used in the purchasing managers' data of the organization provide useful information to help with identification business trends of the organization and its performance, BA Components are divided into three categories: <sup>[13]</sup>

- **BA Server and User Console**

The BA Server, which is the main part in the Pentaho BA Suite responsible for processes reporting, Analysis, and dashboard content. The BA Server hosts the centralized warehouse , enables secure sharing of all BA data, It also provides scheduling and Checking functionality, It is managed by web-based tool . <sup>[13]</sup>

- **Web-Based Design Tools and Plug-in:**

Includes a set of tools that help to the reporting process, Such as Report Designer, Analyzer, Interactive Reporting, Dashboard Designer, and Mobile. <sup>[13]</sup>

- **Client-Based Design Tools:**

Client-based tools include is Aggregation Designer, Metadata Editor, Schema Workbench. <sup>[13]</sup>

#### **3.3.4.2 Data Integration:**

DI Components allows you to connect to and extract data from diverse data sources such as relational databases, No SQL databases, and Hadoop, DI allows provides a visual interface that you can use to transform your data to support business analytics, BA Components are divided into three categories:

- **Data Integration Server**

The DI Server runs centrally stored transformations and jobs, The DI Server also hosts the DI repository and processing engine, provides a service layer for security and authentication, and allows scheduling, Manage the DI Server through its related tool, Spoon. <sup>[13]</sup>

- **Design Tools and Command Line Utilities**

Spoon is the only DI design tool component.

**Spoon:** The DI Server is a main component that executes data integration jobs and transformations using the Pentaho Data Integration Engine, It also provides the services allowing you to schedule and monitor scheduled activities, Drag job entries onto the Spoon canvas, or choose from a rich library of more than 200 pre-built steps to create a series of data integration processing instructions. <sup>[13]</sup>

**Kitchen, Pan, and Carte:** Use Pan to execute PDI transformations, which represent a data stream through a set of independent tasks, Kitchen can orchestrate PDI jobs, which contain transformations and other job entries as part of a larger business process. Use Carte to set up dedicated, remote PDI servers, so you can coordinate jobs across a collection of clustered computers, and execute transformations within a cluster of Carte cluster nodes. <sup>[13]</sup>

- **Plug-in and Command Line Utilities**

PDI has hundreds of plug-in that can be accessed from the marketplace, but there are two plug-in that are installed by default Interview and Agile BI. <sup>[13]</sup>

## 3.4 UML technology:

Unified Modeling Language (UML) is the industry standard language for describing, visualizing, and documenting object-oriented (OO) systems. UML is a collection of a variety of diagrams for differing purposes. Each type of diagram models a particular aspect of OO design in an easy to understand, visual manner. The UML standard specifies exactly how the diagrams are to be drawn and what each component in the diagram means. UML is not dependent on any particular programming language, instead it focuses on the fundamental concepts and ideas that model a system. Using UML enables anyone familiar with its specifications to instantly read and understand diagrams drawn by other people. <sup>[14]</sup> There are UML diagram for modeling static class relationships, dynamic temporal interactions between objects, the usages of objects, the particulars of an implementation, and the state transitions of systems. In general, a UML diagram consists of the following features:

1. **Entities:** These may be classes, objects, users or systems behaviors.
2. **Relationship Lines:** that models the relationships between entities in the system.
3. **Generalization:** a solid line with an arrow that points to higher abstraction of the present item.
4. **Association:** a solid line that represents that one entity uses another entity as part of its behavior.
5. **Dependency:** a dotted line with an arrowhead that shows some entity depends on the behavior of another entity.

## 3.5 System Analysis:

### 3.5.1 Use Case Diagram:

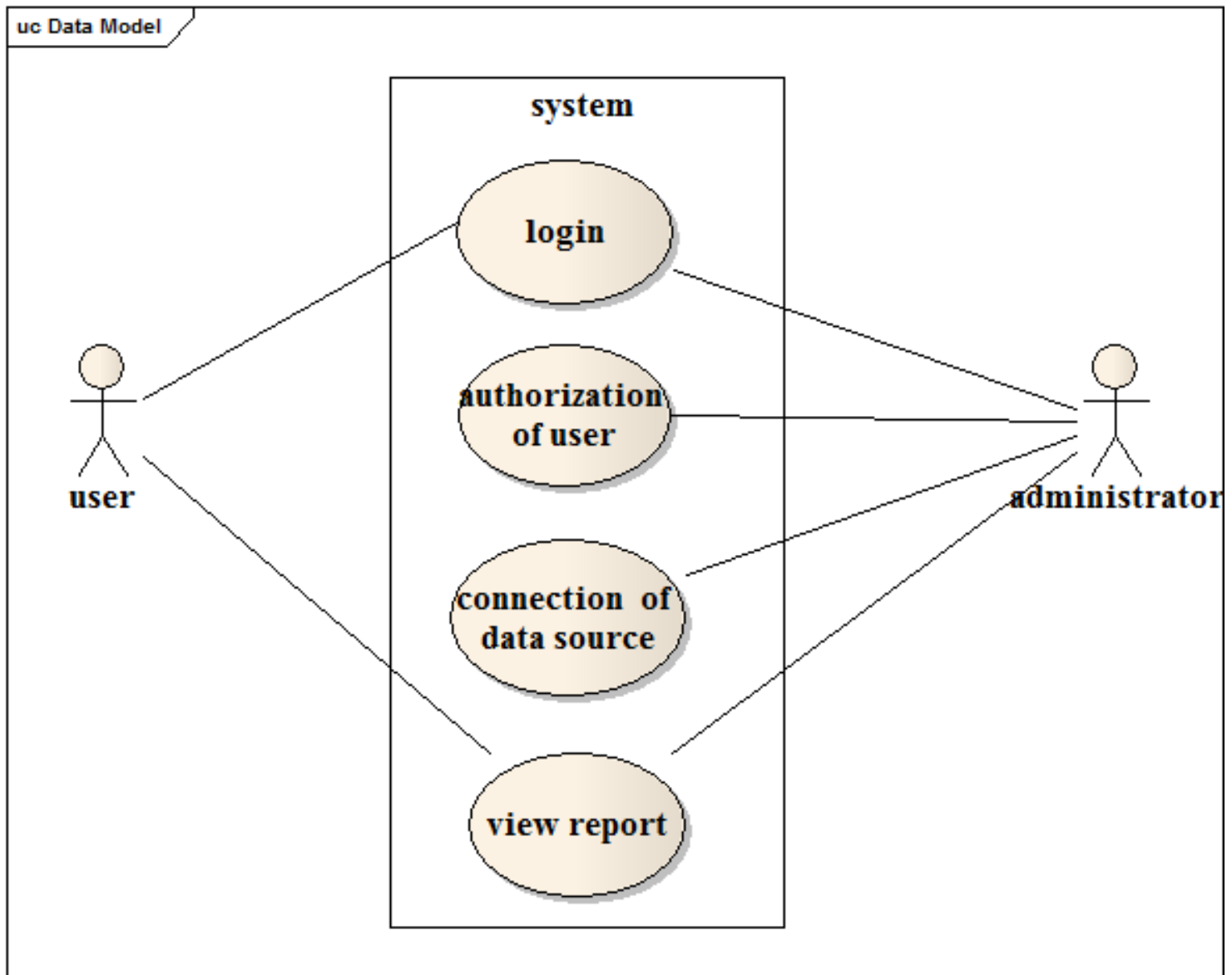

Figure (3. 7) Use Case Diagram for the system



### 3.5.2 Sequence Diagram:

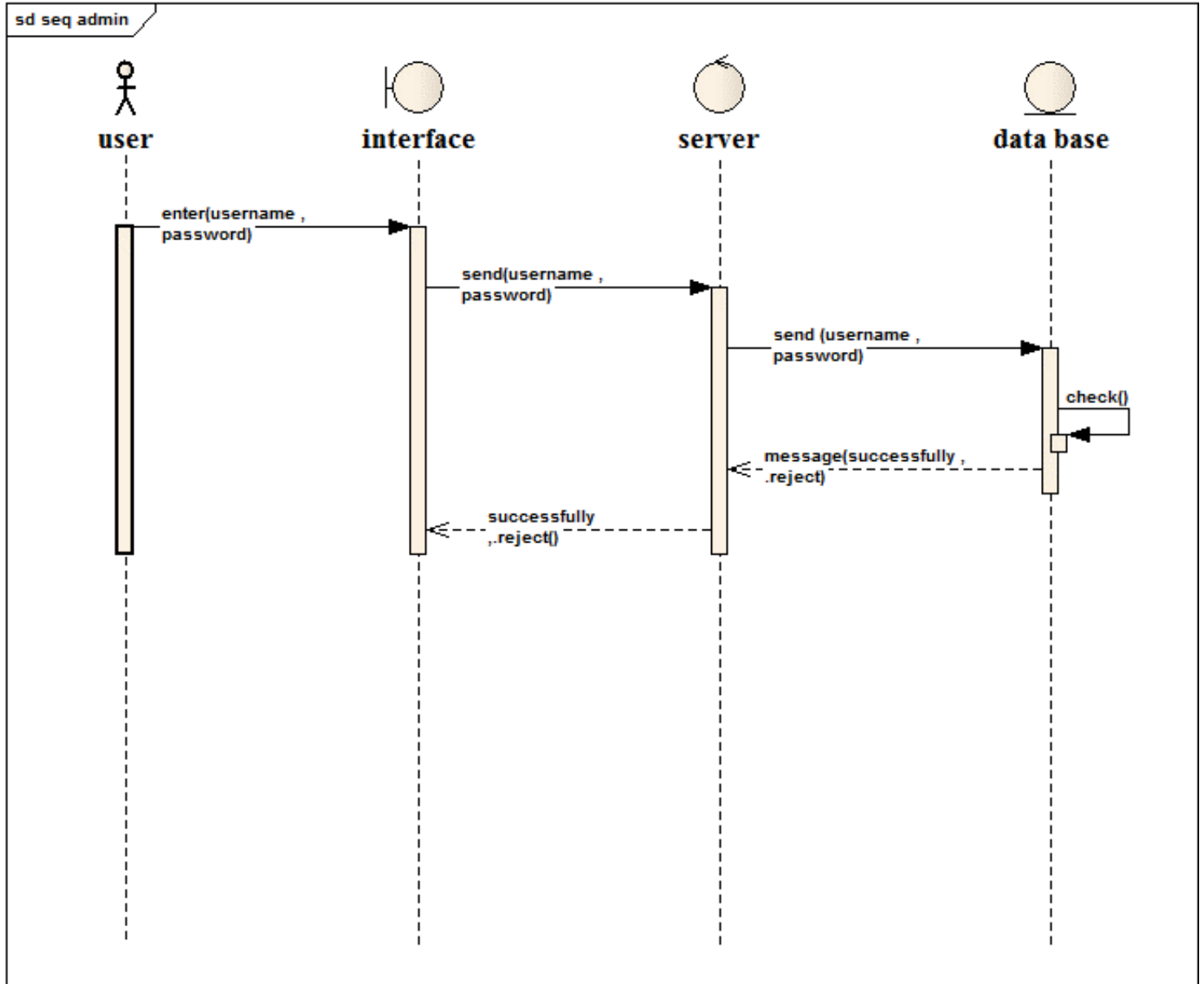

Figure (3. 8) Sequence Diagram for login user

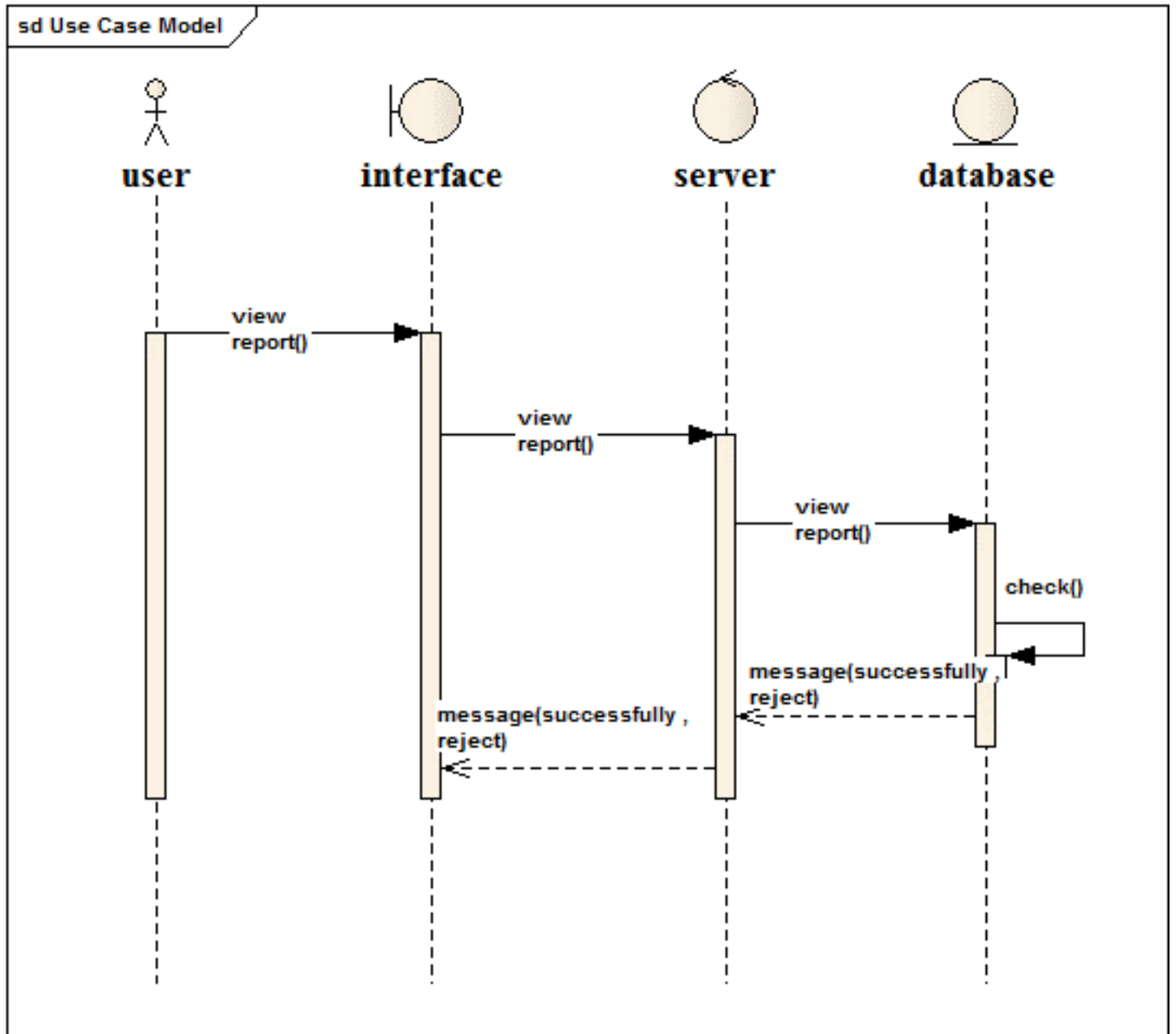

Figure (3. 9) Sequence Diagram view report for user

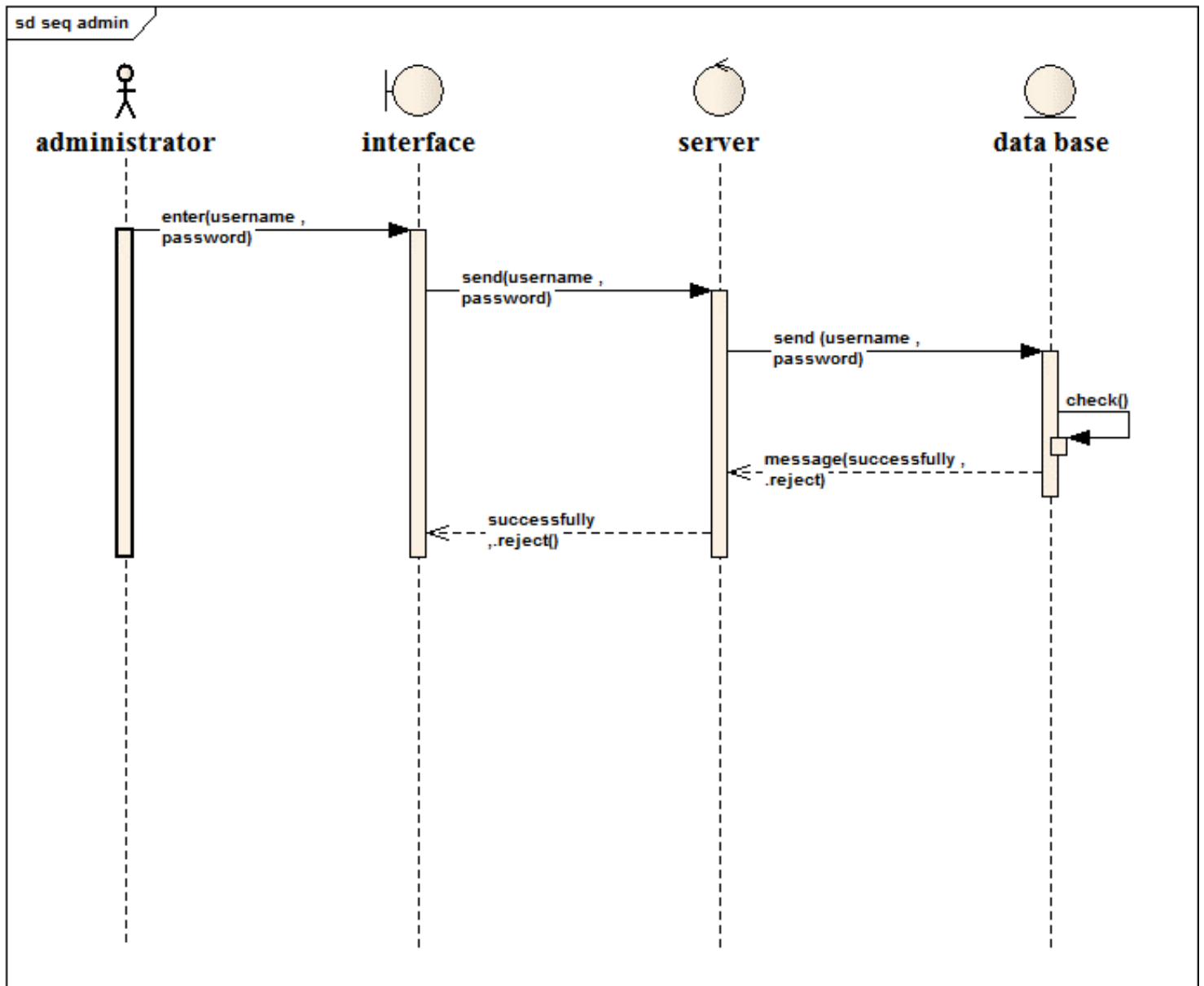

Figure (3. 10) Sequence Diagram login system for administator

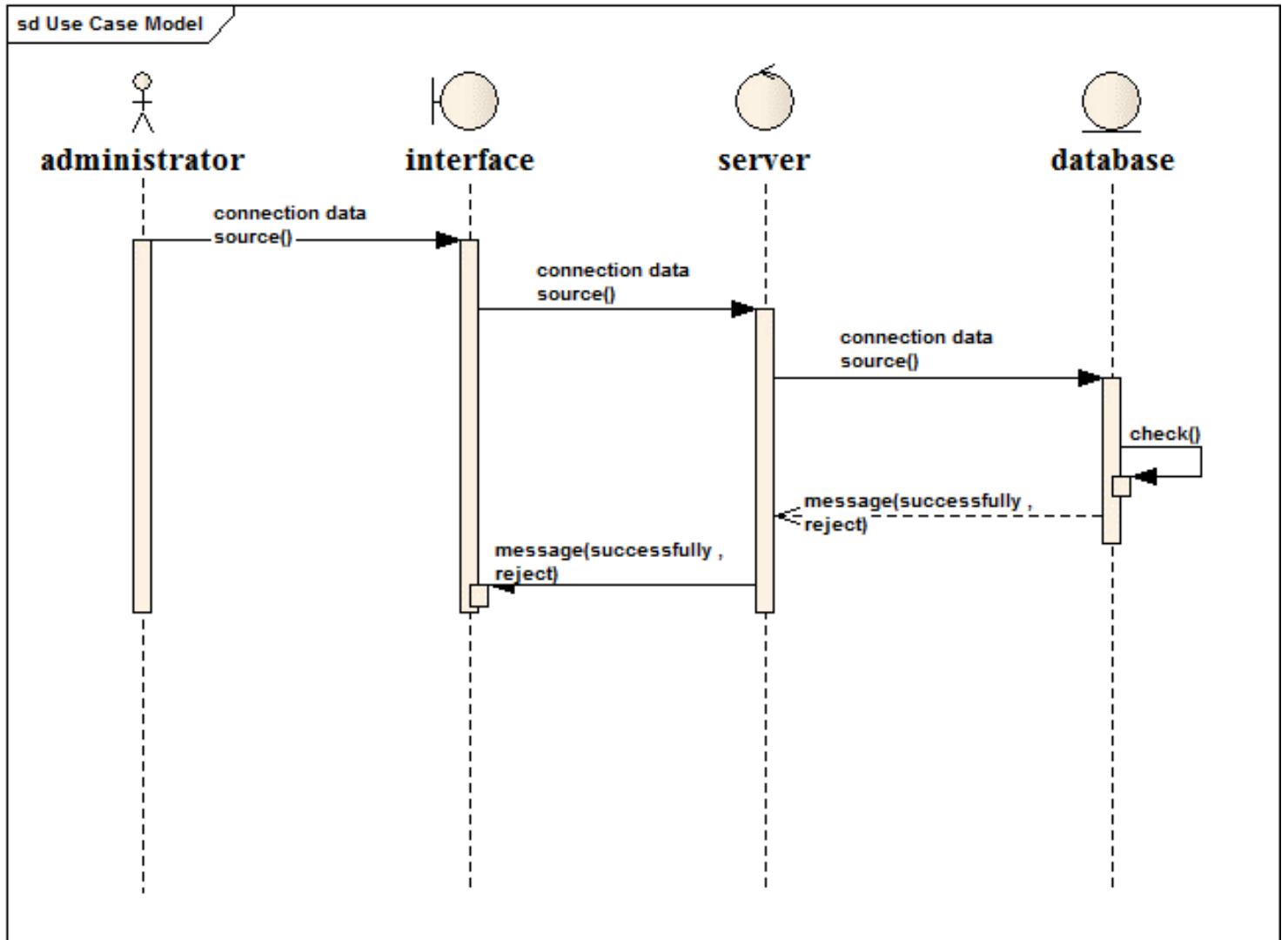

Figure (3. 11) Sequence Diagram connection to data source for administrator

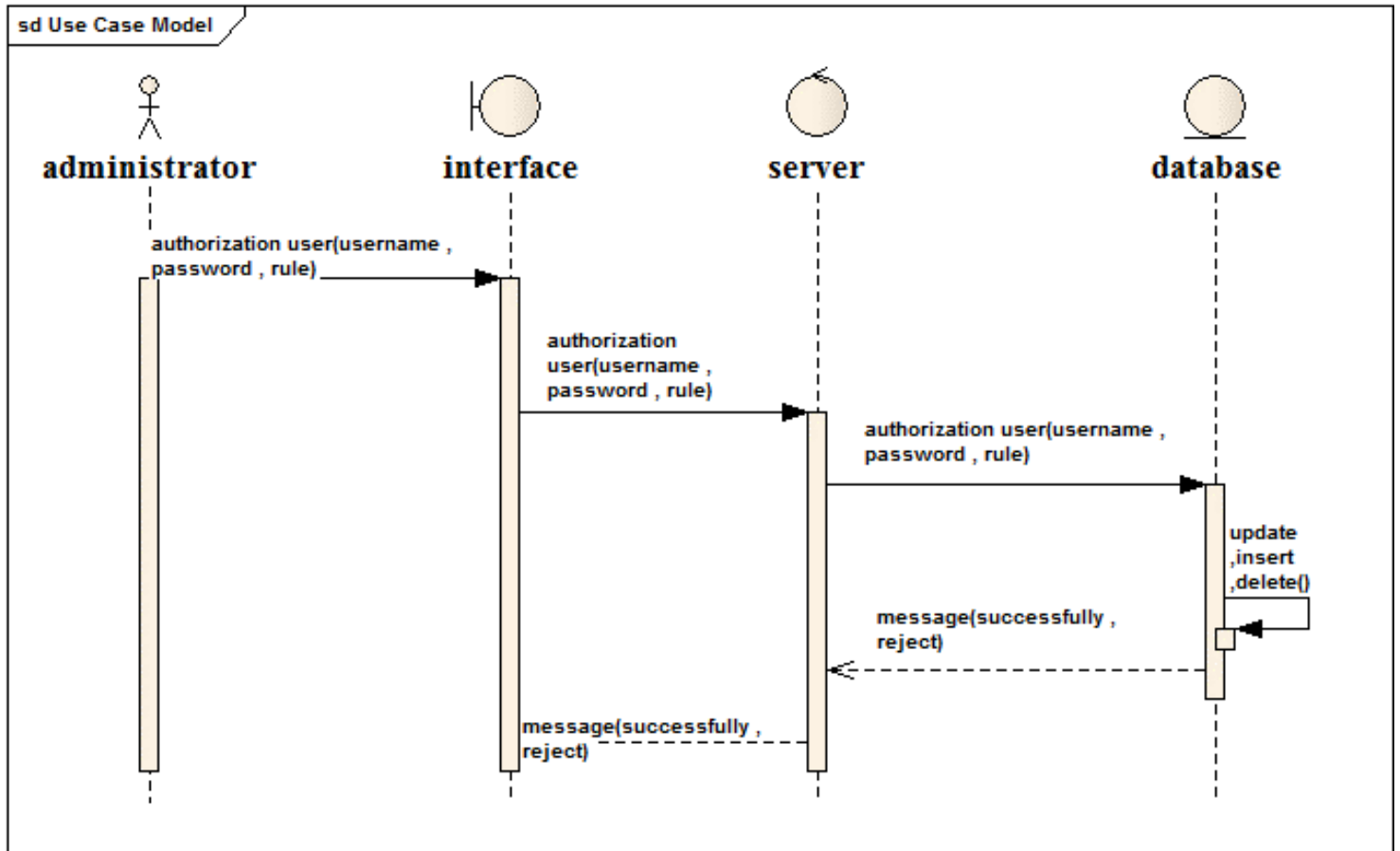

Figure (3. 12) Sequence Diagram authorization for administrator

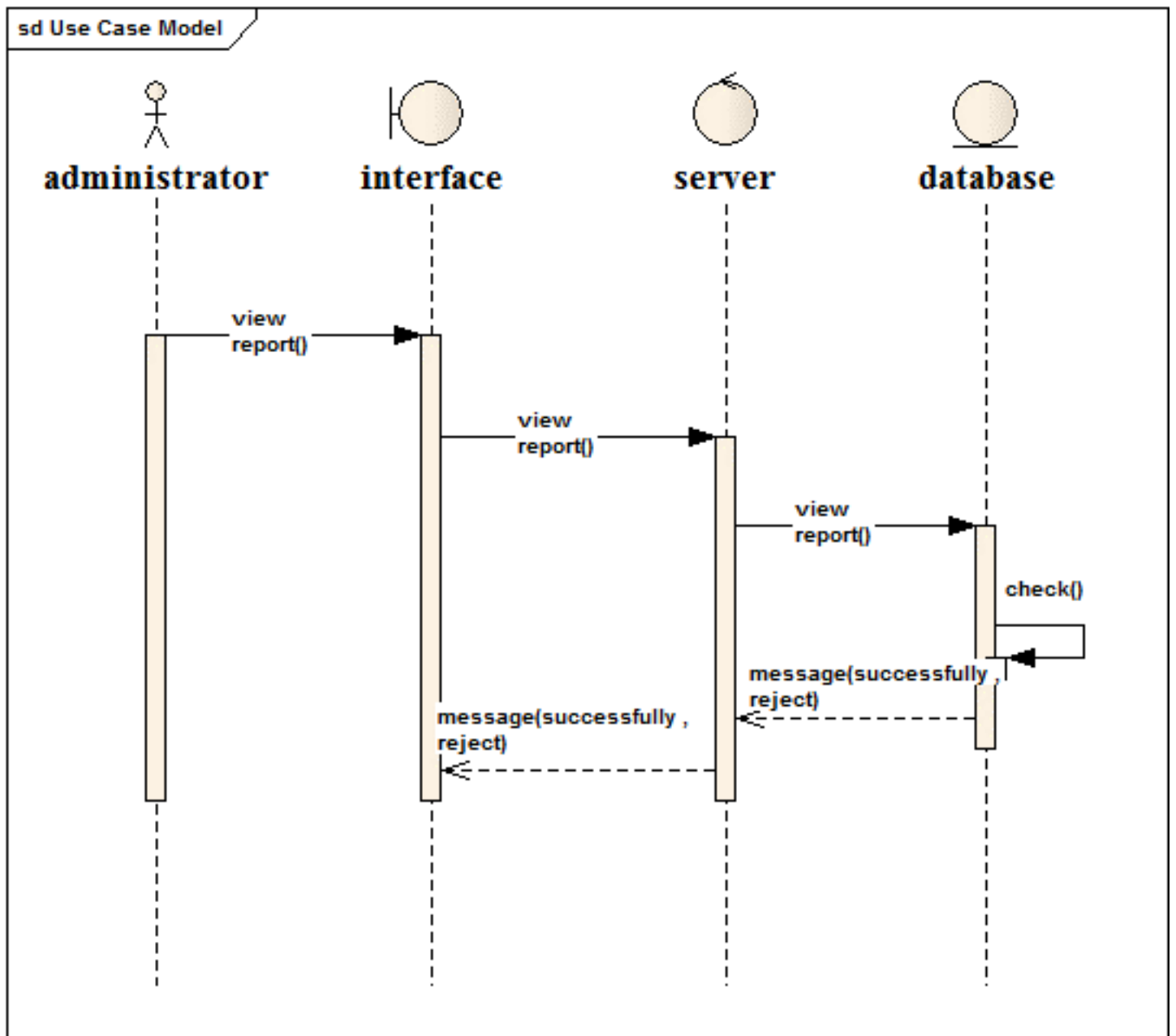

Figure (3. 13) Sequence Diagram view report for administrator

### 3.5.3 Activity Diagram:

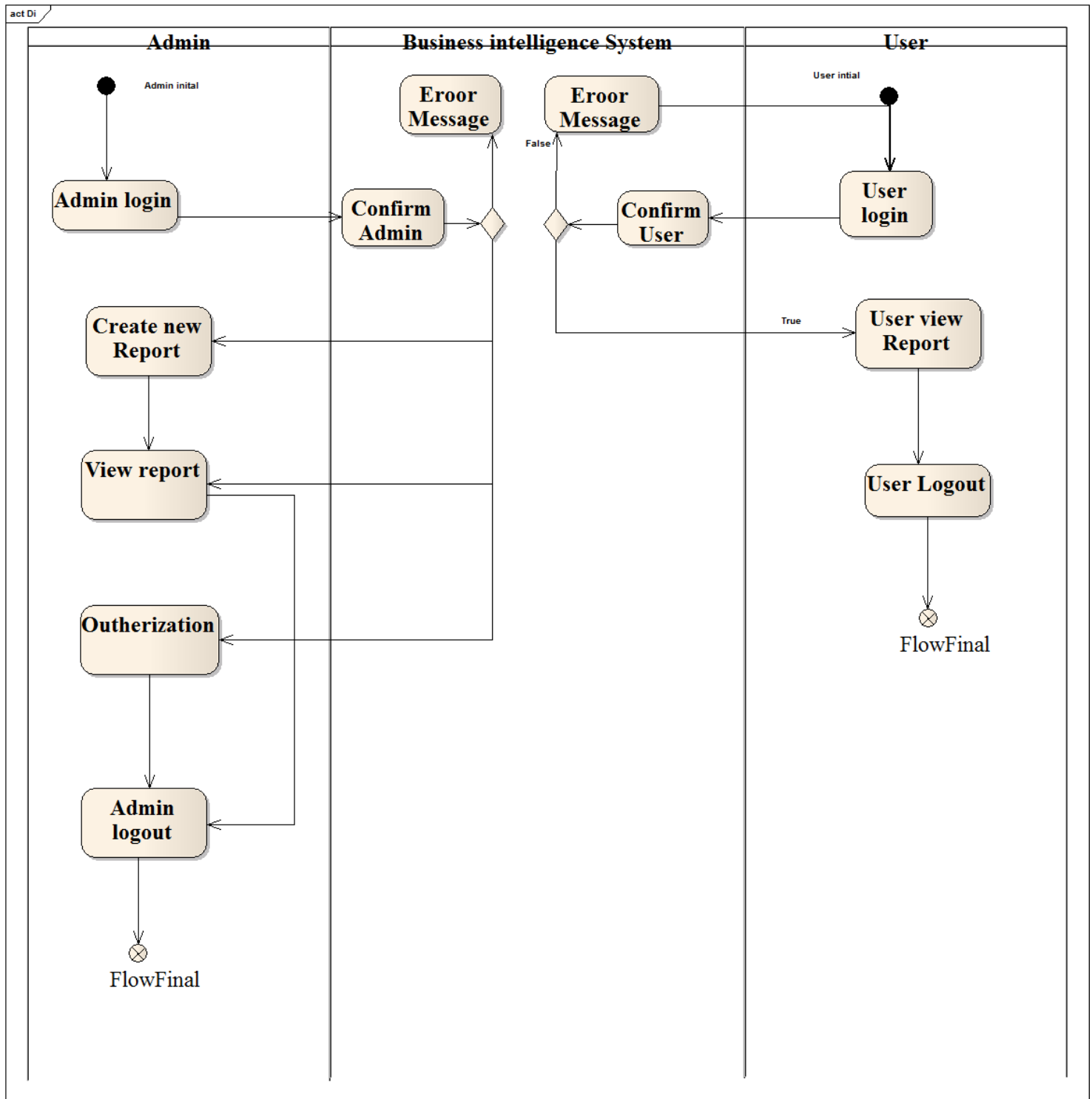

Figure (3. 14) Activity Diagram for System.

**CHAPTER 4**

**RESULTS AND DISCUSSION**



# 4.1 Introduction:

This chapter is divided into two sections, the first section discusses the implementation of the proposed system, and the second section discusses the final results of the system.

# 4.2 system implementation:

## Login to the User Console:-

At the beginning of implementation of the system the pentaho bi server must running it run by this commands (cd opt/pentaho/biserver-ce) to go to the server directory, (sudo -u pentaho ./start-pentaho.sh) to start the server, Then Launch a Web browser and enter the URL of the Pentaho server (localhost:8080), after that pentaho User Console will appear, Then the users can login the pentaho either as administrator or as Business user and after that user must click GO to login, now user have been logged into the User Console and ready to explore.

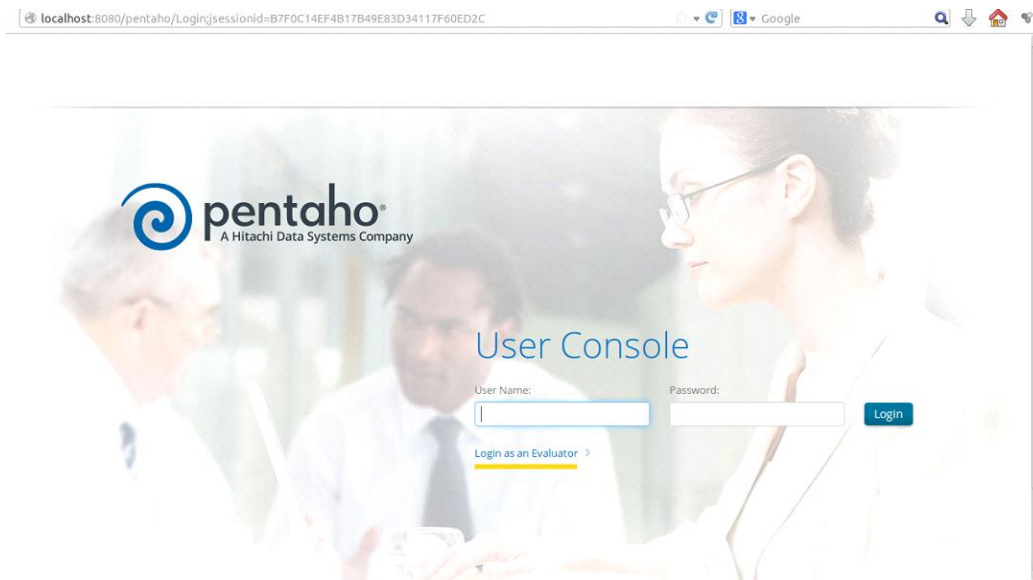

Figure (4. 15) Pentaho login page

After login the pentaho home page will appear which serves as the starting place for the User Console and all of the tasks can do with it.



Figure (4 .16) Pentaho administrator console

**Home** contains easy access buttons so that you can **Browse Files**, **Create New** reports and dashboards, view Pentaho **Documentation**, and quickly open recently viewed or favorite files but this only for admin user, the component of home page are describe below

- **Home** indicator in the top left indicates the current User Console perspective that you are using. The **Home** menu lets you flip easily from page to page, or return to your **Home** page.
- **Pentaho business analyses in the center** displays some resources to help you get familiar with the software.
- **Current User** in the top right shows the name of the person currently logged in to the User Console, clicking the arrow next to the name lets you log out of the User Console.
- **Browse Files** in the left center enable to the **Browse Files** window, Where you can locate your files.
- **Create New** Gives the option to create a new Interactive Report, Analyzer Report, or Dashboard.
- **Documentation** Leads to the Pentaho Info Center, which stores the documentation for Pentaho products.

- **Manage data source** enable connecting to data source to use it in reporting, Analyzer Report, or Dashboard.
- **Resents** Shows a list of the most recently opened files. Clicking on the star next to a recently opened file adds it to **Favorites** list.
- **Favorites** Shows a list of favorite files for quick access.

For non admin user the home page does not contain **Manage data source and Create New buttons** but some type of user can have **Create New button** this user have power user role that create report to other user



Figure (4. 17) Pentaho non administrator console

Pentaho display the report and analyses view in file style, If the user click on **Browse Files** then The **Browse Files** page appear which helps in keep the files and folders organized and makes them easier for user to find and work with, the component of home page are describe below.

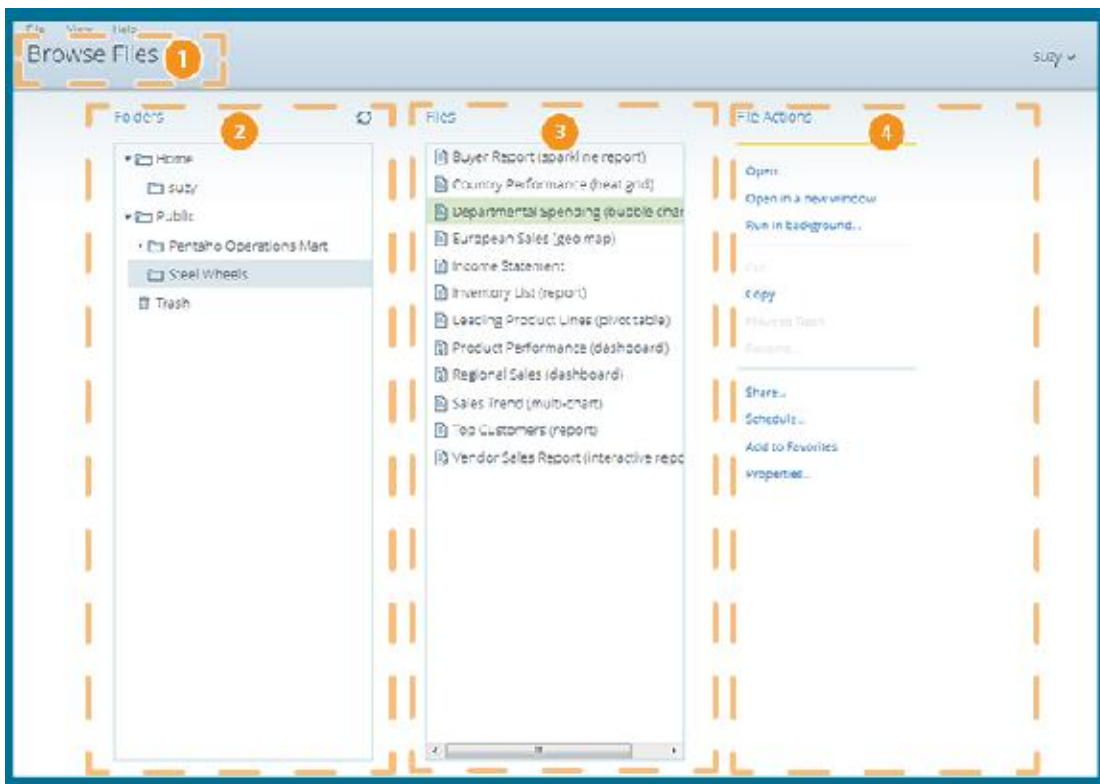

Figure (4. 18) Browse file page

- 1- **Browse Files indicator** Indicates the current User Console perspective that the user are using. Browse Files shows how to locate the files and folders and the different actions that can do with them displays a series of three panes: the Browsing, Files, and Actions panes.
- 2- **Folders** Shows a list of folders that can browse through to locate the files, user can also use the Browsing pane to create new folders or delete old ones, after you select something in the Browsing pane, the Actions pane populates with a list of things you can do with the folders.
- 3- **Files** generates and shows a list of all files contained in the folder that is selected in the Browsing pane, after you select a file, the Actions pane populates with a list of things you can do with the file.
- 4- **File Actions** Shows a list of different things that you can do with the selected folder or file. The Actions pane gives the user the ability to:
  - Quickly open files in the current window or in a new one
  - Run files in the background
  - Edit, delete, cut, copy, or paste files or folders
  - Share files with others
  - Schedule reports to run automatically

- Add files to your Favorites widget
- View the Properties of a file or folder

If user login to pentaho user console as administrator the **manage data source button** will appear that button enable admin to connect to new data source if admin press **manage data source button** the following windows will appear .

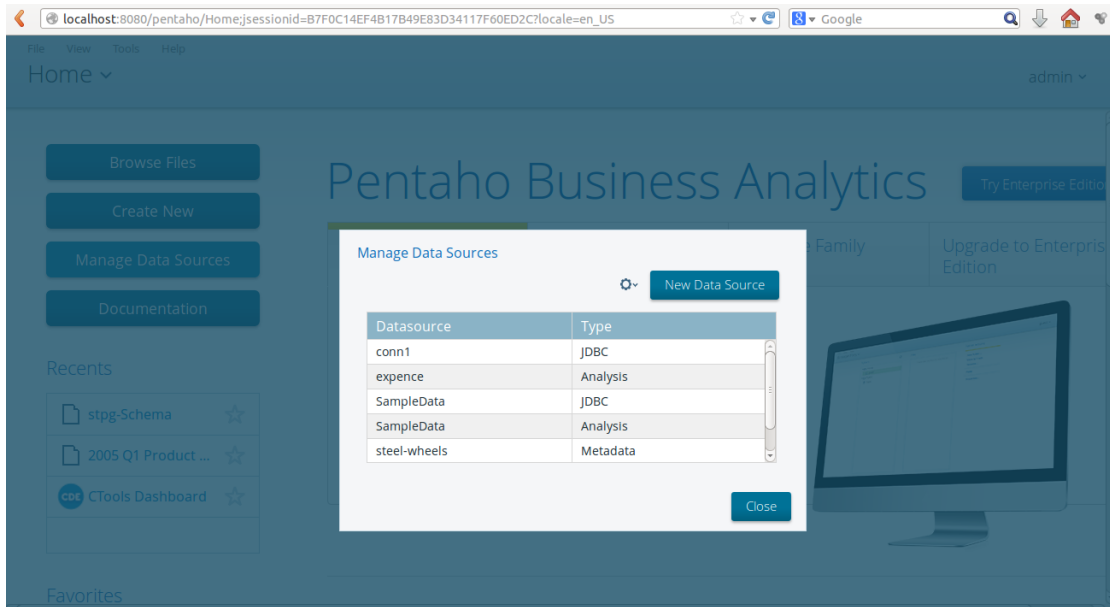

Figure (4. 19) Manage data source

The admin chose the type of data source and click add new or delete existing one update it, if admin chose database as its data source the following windows appear .

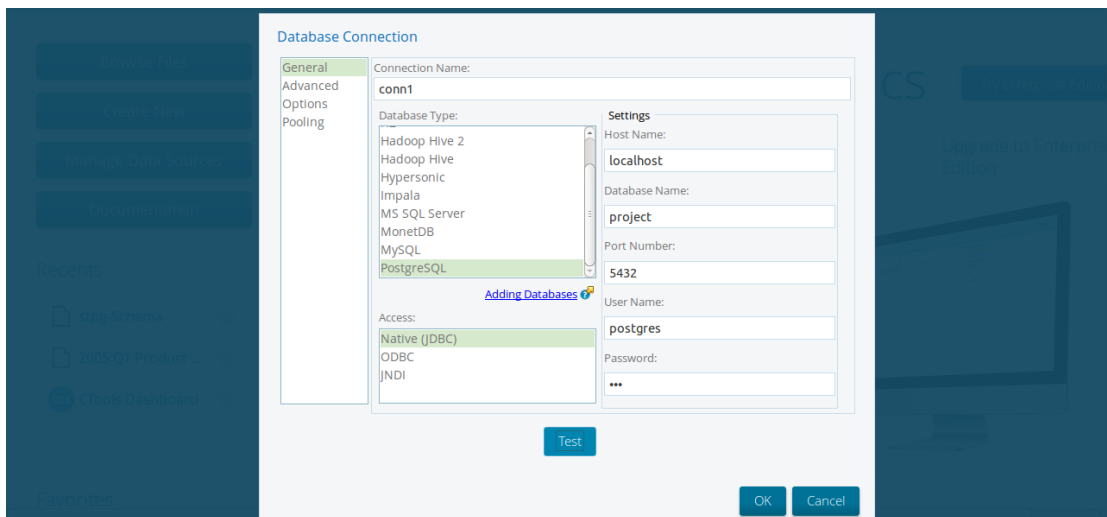

Figure (4. 20) Database as data source connection

Admin must enter the detailed of connection an press Test button

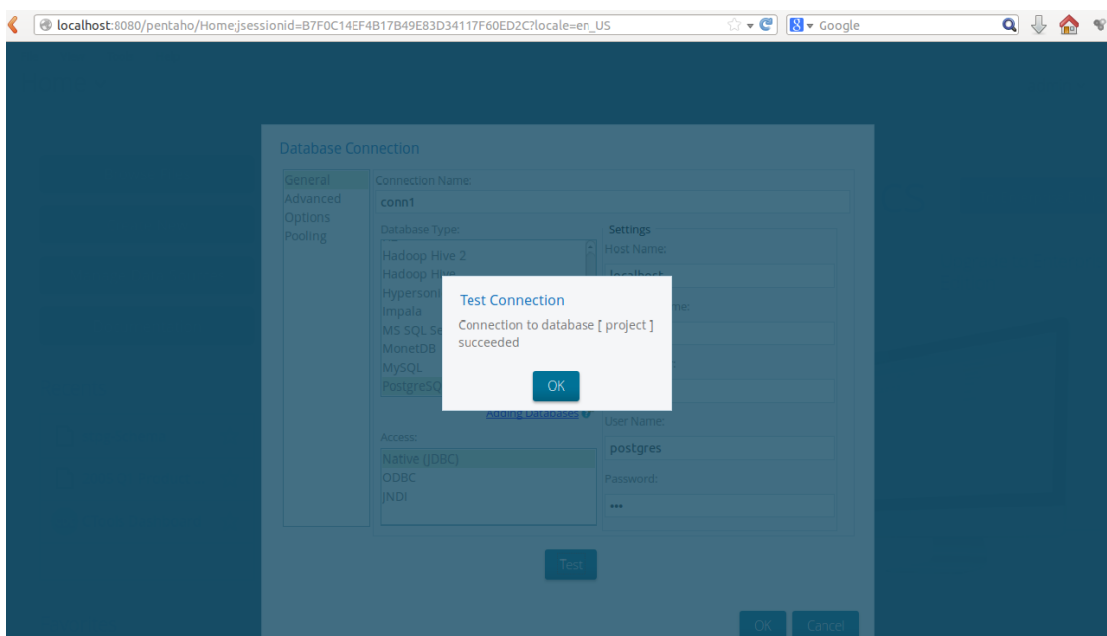

Figure (4. 21) Succeeded message

If succeeded message appear that mean the connection is true if not the error message will appear

Another things that the admin user can do in pentaho user console is to give the role to the user, Control the mail server (server that pentaho send the report to users through it) and another setting

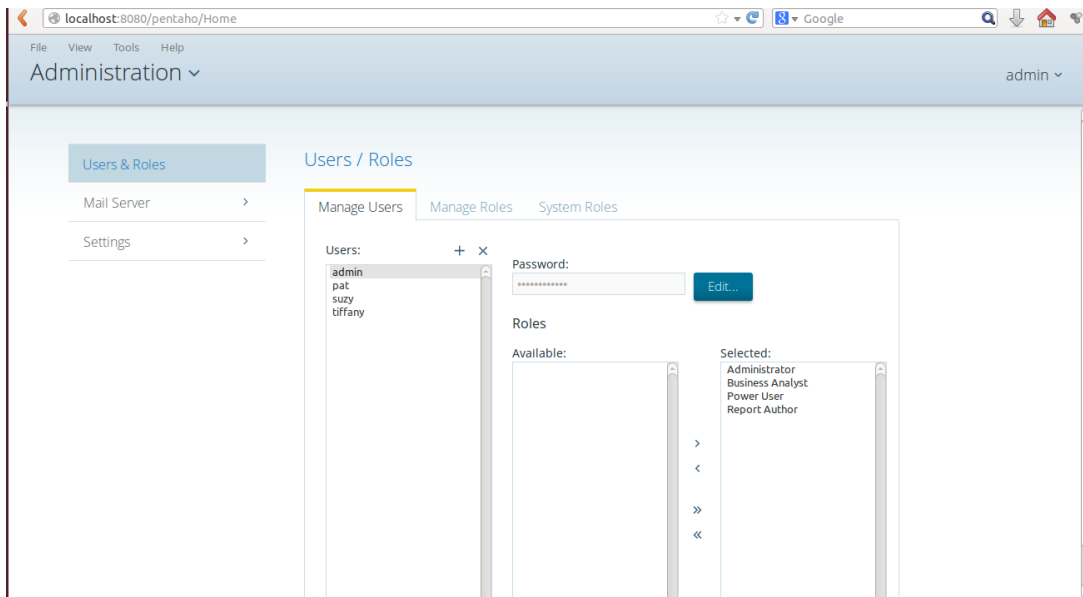

Figure (4. 22) User role

Admin also can control Mail server by insert the detail of it in the following window.

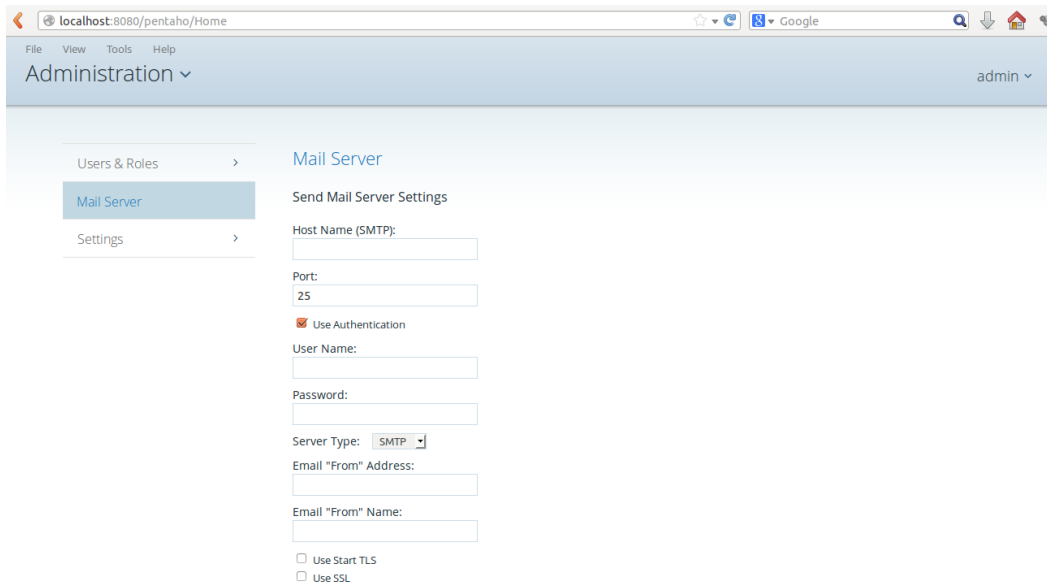

Figure (4. 23) Control mail server

Also admin can control the duration of report and schedule.

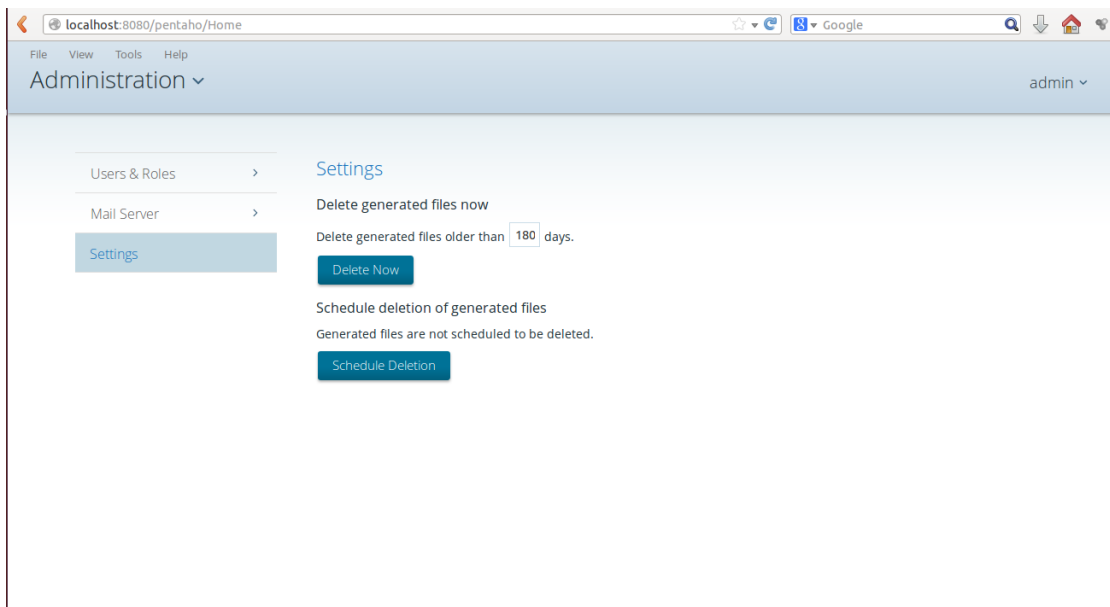

Figure (2. 24) Control thr report duration and schedule

Another task that the admin can do from the user console is schedule reports to run automatically, Admin can go to schedule by clicking the **Home** drop-down menu, then the **Schedules** link, in the upper-left corner of the **Use Console** page.

The list of schedules shows which reports are scheduled to run, The recurrence pattern for the schedule.



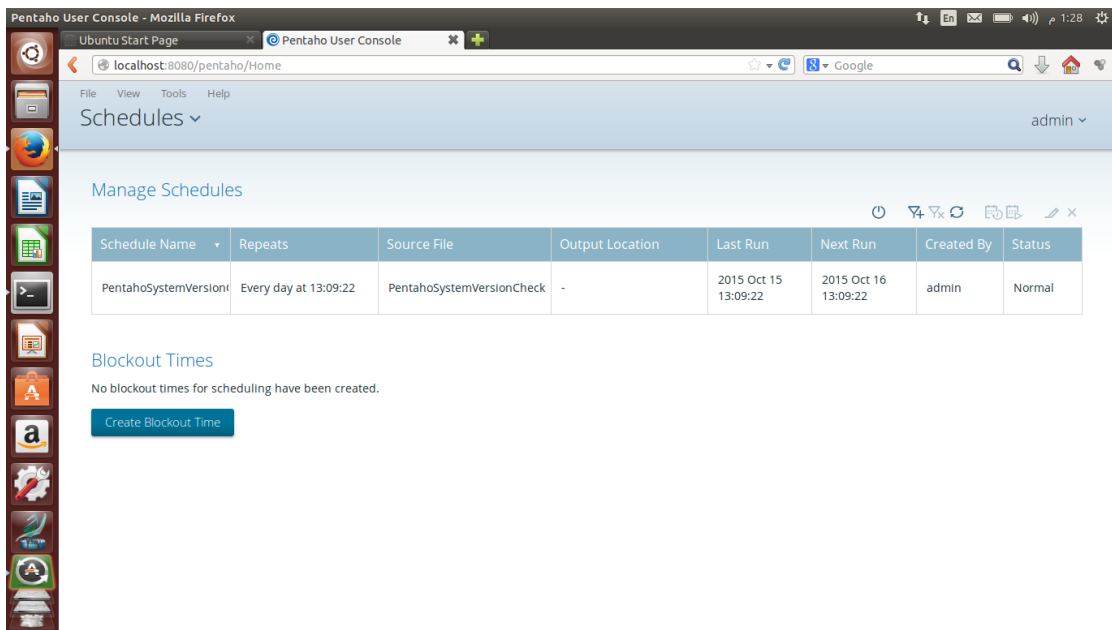

Figure (4. 25) Schedule page

## 4.3 The Result:

This system has been applied on two companies of the Sudanese electricity companies its Sudanese electricity distribution company (SEDC), and the Sudanese thermal production company (STPC), it was applied specifically on accounting data, have been reached to the following result:

- Produce reports showing status of the two companies' accounts state during all time periods, where they help the Ministry of Electricity and Dams to show the accounting performance of the two companies, and provide them with General vision to develop a summary vision of accounts in these companies.
- Produce reports provide information that help in decision-making.

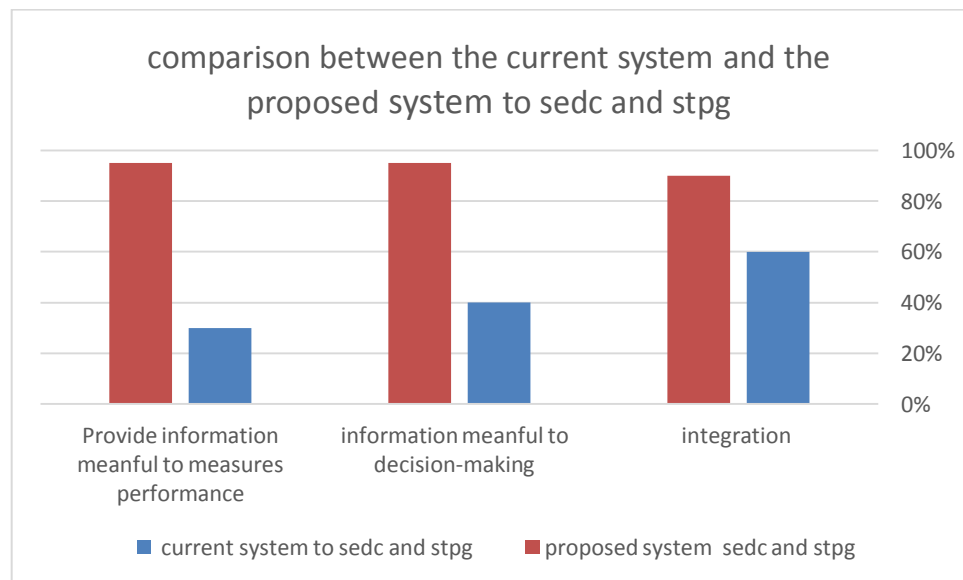

Figure (4. 26) Comparison between the current system and the proposed system

The figure above show the Comparison between the current system and the proposed system from three aspects first provide information to measures performance: the percentage of information that help in measures performance in the current system of sedc and stpc is nearly 30% as their estimation and the percentage after apply the proposed system will be 90%, Secondly provide information to help in decision-making : also the percentage of information that help in decision-making in the current system of sedc and stpc is nearly 40% as their estimation and the percentage after apply the proposed system will be 90%, finally the importance thing is the integration: the percentage of integration between this two company now is nearly 60% as their estimation and the percentage after apply the proposed system will be 90%.

## **CHAPTER 5**

# **CONCLUSION AND RECOMMENDATIONS**

## **5.1 Conclusion:**

Praise of God we were able to provide search that help in applied the business intelligence (BI) in accounting data for Sudanese Distribution Electricity Company (SEDC) and Sudanese Thermal Producing Company (STPC) help in give comprehensive overview of the executive manager and the Ministry of Electricity and Dams of the conditions of companies and provide reports that support the decision-making process.

## **5.2 Recommendations:**

To make this system more valuable and provide attractive value it is recommend doing some tasks:

- Do integration between all parts of the Electricity Sudanese Company, namely: (Sudanese Electricity Distribution Company, Sudanese company to generate water, Sudanese company for thermal generation, Sudanese Transport Company, Merowe Dam).
- Work in all type of data not only accounting data.
- Apply all Business Intelligence Features like dashboard that depend on determine the key performance indicator to measure the performance.

# References:

1. What is Business Intelligence? (2010, January 8). Retrieved 8 19, 2015, from Business Intelligence Knowledge: <http://www.business-intelligence-knowledge.com/>
2. A Business Intelligence System. (1958). IBM journal.
3. History of Business Intelligence. (2014, September 26). Retrieved August 30, 2015, from betterbuys
4. Robert Stackowiak, J. R. (2007). Warehousing and Business Intelligence Solutions. Indiana: Wiley Publishing, Inc.
5. DATA WAREHOUSE TUTORIAL. (n.d.). [tutorialspoint.com](http://tutorialspoint.com).
6. ن. بولودان. (2012). دور مستودعات البيانات في تحسين. عمان. جامعة الزيتونة الأردنية: كلية الاقتصاد والعلوم الإدارية, جامعة الزيتونة الأردنية
7. Dongen, R. B. (Manufactured in the United States of America). Business Intelligence and Data Warehousing with Pentaho and MySQL. Indiana: Wiley Publishing.
8. Open Source Business Intelligence Tools - Advantages. (2010, January 29). Retrieved 8 20, 2015, from Business Intelligence Knowledge: <http://www.business-intelligence-knowledge.com/2010/01/open-source-business-intelligence-tools-advantages/>
9. Pentaho helps the Rio Negro Province to recover money and prepare for the future. (2014). pentaho
10. Web Assign Uses Business Analytics to Improve Education . (2015). Pentaho.
11. Metro Bank Building a bank that can surprise and delight with Power BI. (n.d.). Retrieved from microsoft: <https://powerbi.microsoft.com/>
12. Ernie Mazuin Mohd Yusof, M. S. (2013). The Study on the Application of Business Intelligence in Manufacturing . International Journal of Computer Science Issues.
13. Get Acquainted with Pentaho Components. (2014). Pentaho Corporation.
14. Online]. <http://www.ibm.com/developerworks/rational/library/769.html> may 204 10:12 PM.

# Appendix A:

Table (A.1) comparison between pentaho and other open source tool

Criteria	Pentaho	BIRT	JasperSoft
<b>Data source</b>			
<b>Data Sources Type</b>	<ul style="list-style-type: none"> <li>•Generic JDBC</li> <li>•XML</li> <li>•Manual Table</li> <li>•OLAP</li> <li>•Pentaho Analysis</li> <li>•XML/A via OLAP4j</li> <li>•Pentaho Metadata</li> <li>•Pentaho Data Integration</li> <li>•POJO</li> <li>•EJB</li> <li>•Hibernate</li> <li>•JMI</li> <li>•Hadoop Hive</li> <li>•Hadoop Hive 2</li> <li>•Native Modrian</li> <li>•OpenERP Server</li> <li>•Palo MOLAP Server</li> <li>SAP ERP System</li> </ul>	<ul style="list-style-type: none"> <li>•Generic JDBC</li> <li>•XML</li> <li>•Web Services</li> <li>•Flat files:</li> <li>•CSV SSV PSV TSV</li> <li>•Hadoop Hive</li> <li>•OLAP MDX</li> <li>•POJO</li> <li>•MongoDB</li> <li>•EJB</li> <li>•Hibernate</li> <li>XML Stream</li> </ul>	<ul style="list-style-type: none"> <li>•Generic JDBC</li> <li>•AWS</li> <li>•Bean</li> <li>•Hadoop Hive</li> <li>•Internal Diagnostic</li> <li>•JNDI</li> <li>•MongoDB Virtual</li> </ul>
<b>Output</b>			
<b>Output Format</b>	<ul style="list-style-type: none"> <li>•PDF</li> <li>•Paged HTML</li> <li>•Streaming HTML</li> <li>•CSV</li> <li>•Excel (XLS, XLSX)</li> <li>RTF</li> </ul>	<ul style="list-style-type: none"> <li>•HTML</li> <li>•XML</li> <li>•PDF</li> <li>•OpenOffice (ODP, ODS, ODT)</li> <li>•Document(DOC,DOCX)</li> <li>•Excel (XLS, XLSX, XLS_SPUDSOFT)</li> <li>•PowerPoint (PPT, PPTX)</li> <li>Postscript</li> </ul>	<ul style="list-style-type: none"> <li>•PDF</li> <li>•Excel(XLSX)</li> <li>•CSV</li> <li>•Document(DOCX)</li> <li>•RTF</li> <li>OpenOffice (ODS, ODT)</li> </ul>
<b>Charts</b>	<ul style="list-style-type: none"> <li>•Area</li> <li>•Bar</li> <li>•Bar Line</li> <li>•Bubble</li> <li>•Extended XY Line</li> <li>•Line</li> <li>•Multi Pie</li> <li>•Pie</li> <li>•Radar</li> <li>•Ring</li> <li>•Scatter</li> <li>•Waterfall</li> <li>•XY Area</li> <li>•XY Area Line</li> </ul>	<ul style="list-style-type: none"> <li>•Area</li> <li>•Bar</li> <li>•Bubble</li> <li>•Cone</li> <li>•Difference</li> <li>•Gantt</li> <li>•Line</li> <li>•Meter</li> <li>•Pie</li> <li>•Pyramid</li> <li>•Radar</li> <li>•Scatter</li> <li>•Stock</li> <li>Tube</li> </ul>	<ul style="list-style-type: none"> <li>•Column</li> <li>•Bar</li> <li>•Bubble</li> <li>•Scatter</li> <li>•Line</li> <li>•Area</li> <li>•Pie</li> <li>•Candlestick</li> <li>•Gantt</li> <li>•High-low</li> <li>•Thermometer</li> <li>Widget (coming soon)</li> </ul>

	<ul style="list-style-type: none"> <li>•XY Bar</li> <li>XY Line</li> </ul>		
<b>Report Designer</b>			
<b>Tool</b>	Pentaho Report Designer	BIRT Designer	JasperSoft Studio
<b>Report Format</b>	XML Report file (.PRPT) is a ZIP of Design and other resources	XML (.RPTDESIGN)	Report design files (.JRXML) compile to Java Byte Code (.JASPER) Deploy/Run .JASPER files
<b>Common Report Designer Components: Report Editor, Palette, Data Explorer, Property Editor, Outline view of structure, Preview, Expression Builder, Report Problems, Chart Builder, Script Editor</b>	√	√	√
<b>Report Items</b>	<ul style="list-style-type: none"> <li>•Label</li> <li>•Text Field</li> <li>•Number Field</li> <li>•Date Field</li> <li>•Message</li> <li>•Image</li> <li>•Resource Label</li> <li>•Resource Field</li> <li>•Resource Message</li> <li>•Resource Image</li> <li>•Sub Report</li> <li>•Barcodes</li> <li>•Table of Content</li> <li>•Index</li> <li>•Geometric shapes</li> <li>•Hyperlinks within a report</li> <li>Actionable charts (drill downs, hover over, hyperlinks)</li> </ul>	<ul style="list-style-type: none"> <li>•Label</li> <li>•Text</li> <li>•Dynamic Text</li> <li>•List</li> <li>•Grid</li> <li>•Data</li> <li>•Image</li> <li>•Chart</li> <li>•Table</li> <li>•CrossTab</li> <li>•Horizontal Panning</li> <li>•Geometric shapes</li> <li>•Barcodes</li> <li>•Hyperlinks within a report</li> <li>Actionable charts (drill downs, hover over, hyperlinks)</li> </ul>	<ul style="list-style-type: none"> <li>•Text Field</li> <li>•Static Text</li> <li>•Image</li> <li>•Chart</li> <li>•Spider Chart</li> <li>•List</li> <li>•Frame</li> <li>•Generic Element</li> <li>•Geometric shapes</li> <li>•Barcodes</li> <li>•Table</li> <li>•CrossTab</li> <li>•Horizontal Panning</li> <li>•Sub-reports</li> <li>•Hyperlinks within a report</li> <li>•Actionable charts (drill downs, hover over, hyperlinks)</li> <li>Newspaper / multi-column layout</li> </ul>
<b>Data Integration</b>			
<b>Tools</b>	Pentaho Data Integration (Kettle)	N/A	•Job Designer Transformation Mapper
<b>Components</b>	<ul style="list-style-type: none"> <li>•ETL(Extract/Transform/Load) for data</li> <li>•data migration</li> <li>Big Data</li> </ul>	N/A	<ul style="list-style-type: none"> <li>•design, schedule and execute data movements graphically</li> <li>•allow simultaneous input and output to and from various sources using flat files, XML</li> </ul>

			files, web services, databases and servers with a multitude of connectors <ul style="list-style-type: none"> <li>•make configurations of heterogenous data sources and complex data formats (incl. positional, delimited, XML and LIDF with metadata wizards)</li> </ul> able to generate portable Java or Perl code which can be executed on any machine
<b>Output</b>	procedures written in XML format.	N/A	procedures compiled in Java
<b>Elements</b>	<ul style="list-style-type: none"> <li>•Schema</li> <li>•Cube</li> <li>•Virtual Cube</li> <li>•Cube Usages</li> <li>•Cube Usage</li> <li>•Virtual Cube Dimension</li> <li>•Virtual Cube Measure</li> <li>•Dimension</li> <li>•Dimension Usage</li> <li>•Hierarchy</li> <li>•Level</li> <li>•Key Expression</li> <li>•Name Expression</li> <li>•Caption Expression</li> <li>•Ordinal Expression</li> <li>•Parent Expression</li> <li>•Property</li> <li>•Property Expression</li> <li>•Measure</li> <li>•Calculated Member</li> <li>•Named Set</li> <li>•Table</li> <li>•View</li> <li>•Join</li> <li>Inline Table</li> </ul>	<ul style="list-style-type: none"> <li>•Cube</li> <li>•Measure</li> <li>•Dimension</li> <li>•Filters</li> <li>•ACL Expression</li> <li>Event Handler Class</li> </ul>	