



Sudan University of Science and Technology
College of Graduate studies

Accuracy

Accuracy Investigation of The of Billing Systems in
Sudanese Telecommunication Companies

التحقق من دقة أنظمة الدفع في شركات الاتصالات
السودانية

A Thesis Submitted in Partial Fulfillment of the Requirements of
Master Degree in Computer Science

By:

AL Sharif Hago Almugadam Yusuf

Supervisor:

Dr. Yahiya Abdullah Mohamed

October16

بسم الله الرحمن الرحيم

﴿أَفْمَأْ بِاسْمِ رَبِّكَ الَّذِي خَلَقَ (1) خَلَقَ الْإِنْسَانَ مِنْ عَلَقٍ (2)
أَفْرَأَ وَرَبُّكَ الْأَكْرَمُ (3) الَّذِي عَلَّمَ بِالْقَلَمِ (4) عَلَّمَ الْإِنْسَانَ مَا
لَمْ يَعْلَمْ (5)﴾ سورة العلق.

Abstract

The aim of this study is to investigate, measure and analyze the Accuracy of billing systems in Sudanese telecommunication companies (Op3, Op2, OP1 and Op4),by measuring the actual data (voice calls) from the GSM/Modem and comparing it to the extracted data from the billing systems within the telecom operators.

To study the problem and test the proposed solution the following steps has been performed: Identifying call duration, Determining the Price List of the call according to selected telecom company, Receiving call by using ATA command to answer the call, Calculating the accurate cost of call according to specified price and call duration, by

multiplying the call duration in selected price to get the total cost of call, Generating Reports which used to generate Actual reports from the voice calls, price/cost/Quality to make comparisons between actual voice calls throw GSM/Modem and ordinary voice calls , throw Billing Systems that telecommunication companies generated.

The thesis experiments proved the accuracy of the billing system inside OP1 network and outside OP1 network to Op3 telecom company, but it is lacks some precision when calling from OP1 to Op2 telecom company, also the results proved accuracy of billing system in Op2 telecom company when calling from Op2 to Op3 and OP1 telecom companies (Off-Net), but it is lacks some precision when calling from Op2 to Op2 (On-Net), and also the results proved accuracy of billing system inside Op3 Telecom including On Net Calls when calling from Op3 to Op3 and Off Net Calls when calling from Op3 to OP1telecom and Op3 to Op2telecom.

المستخلص

الهدف من هذه الدراسة هو القيلس والتحقق من دقة جودة انظمة الدفع في شركات الاتصالات السودانية(مشغل 1, مشغل 2,مشغل 3 و مشغل 4) يتم ذلك عن طريق مقارنة القيم الحقيقية (المكالمت الصوتية) الناتجة من النظام التي تم بناؤة مع القيم الناتجة من انظمة الدفع داخل شركات الاتصالات.

لدراسة المشكلة و إختبار الحل المقترح تم تطبيق الخطوات التالية: تحديد مدة المكالمة, ثم اختيار تعرفه المكالمة حسب الشركة المختارة لان كل شركة لديها سبيلساتها في تحديد التعرفه, الرد علي المكالمه عن طريق (ATA)

Command) حسب التكلفة لكل مكالمة حسب التعرف المصحلة عن طريق ضرب التعرف في مدة المكالمة ومنها حسب التكلفة النهائية للمكالمة, استخراج التقارير النهائية ومقارنتها مع التقارير المستخرجة من شركات الاتصالات. نتائج الإختبارات في هذه الدراسة أظهرت أن نظام الدفع في مشغل 1 يعمل بصورة دقيقة في حسب تكلفة و ازمة المكالمات داخل شبكة ام تي انمشغل 1 و خارج شبكة مشغل 1 لشبكة شركة مشغل 3 ويفتقر لبعض الدقة عند الاتصال من شركة مشغل 1 لشركة مشغل 2, نتائج الإختبارات أظهرت أيضا أن نظام الدفع في شركة مشغل 2 يعمل بصورة دقيقة في حسب تكلفة و ازمة المكالمات خارج شبكة مشغل 2 لشبكة مشغل 1 و شبكة شركة مشغل 3 ويفتقر لبعض الدقة عند الاتصال داخل شبكة مشغل 2, لما نظام الدفع في شركة مشغل 3 فقد أظهرت الاختبارات دقة داخل شبكة شركة مشغل 3 وذلك عند الاتصال من شبكة مشغل 3 لشبكة مشغل 3 وخارج شبكة شركة مشغل 3 عند الاتصال من شبكة مشغل 3 لشبكة مشغل 1 وشبكة مشغل 2.

Dedication

To my dear Mother FATIMA, You have provided the guidance I needed throughout my life, things just seem to get a little more complicated the older I get. Thanks for all your support, you're always near a tender smile to guide my way you're the sunshine to light my life.

To my dear father HAGO ALMOGADAM Thanks for being there when I need you the most and even when I didn't. To all my family members whom were source of success, by giving me the confidence.

Acknowledgements

All Praise is due to Allah first and last for helping me to complete this thesis. This thesis also would not have been possible without the support of many people. Thanks to my supervisor Dr.Yahia Abdullah Mohamed who read my numerous revisions and helped. Also thanks to teacher Intisar Ibrahim who offered guidance and support and special thanks to Eng. HassanMokhtar the Head of quality department in NTC.

Finally, thanks to all my friends who endured this long process with me and always offered support.

Table of Content

Abstract.....	2
المستخلص.....	2
Dedication.....	3
Acknowledgements.....	4
Table of Figures.....	6
CHAPTER 1.....	8
INTRODUCTION.....	8
1.1 Introduction:.....	8
1.2 Problem Statement:.....	8
1.3 Research Questions:.....	9
1.4 Objectives:.....	9
1.5 Scope:.....	9
1.6 Thesis Layout:.....	9
CHAPTER 2.....	10
BACKGROUND TO BILLING SYSTEMS	10
2.1 Introduction.....	10
2.2 Telecoms Billing Overview:.....	11
2.4 Suspense:.....	12
2.5 Reconciliation:.....	12
2.6 Billing:.....	13
2.7 Billing Types:.....	13
2.8 Related Studies:.....	14
CHAPTER 3.....	16
WORK ENVIRONMENT AND PROPOSED SYSTEM ANALYSIS.....	16
3.1 Introduction:.....	16
3.2 System Requirement specification.....	16
3.3 Techniques used in the system:.....	17

3.3.1 GSM Technology:.....	17
3.3.2 GSM Modem:.....	18
3.3.3SIMCard:.....	18
3.3.4 .Net Framework:.....	18
3.3.5 C# Programming Language:.....	19
3.3.6 Crystal Report:.....	19
3.3.7 SQL Server 2012:.....	19
3.3.8 UML technology:.....	19
3.4 How The System Works:.....	19
3.4.1 GSM/Modem Commands:.....	19
3.4.1.1 Basic Commands and Extended Commands:.....	20
3.4.2 Setup and Verify The GSM Modem:.....	20
3.4.3 Identifying of call duration:.....	21
3.4.4 Determining the Price List:.....	21
3.4.5 Receiving call:.....	21
3.5 System Analysis:.....	22
3.5.1 Use Case Diagram:.....	22
3.5.2 Sequence Diagram:.....	22
3.5.3 Activity Diagram:.....	23
CHAPTER 4.....	23
RESULTS AND.....	23
DISCUSSION.....	23
4.1 Introduction:.....	24
4.2 Results:.....	24
4.2.1 Metering and Cost of call:.....	24
CHAPTER 5.....	32
CONCLUSION AND RECOMMENDATIONS.....	32
5.1Conclusion:.....	32
5.2 Recommendations:.....	33
References:.....	33
Appendix A:.....	35

Table of Figures

CHAPTER 1

INTRODUCTION

1.1 Introduction:

Telecommunication companies need an effective and accurate billing system to be able to assure their revenue. Billing systems process the usage of network equipment that is used during the service usage into a single Call Detail Record (CDR). the billing

process involves receiving billing records from various networks, determining the billing rates associated with the billing records, calculating the cost for each billing record, aggregating these records periodically to generate invoices, sending invoices to the customer, and collecting payments received from the customer[1].

The modern digital structures provided by billing software services and products are part of what has propelled businesses into the new digital era, allowing for more productivity and greater ease of business administration in general[2].

In this research study, the NTC (National Telecommunication Corporation) of telecom sector or the mobile service providers like OP3, OP1, OP2, Op4 operating in Sudan were targeted as the main targets while price fairness and quality of billing systems were taken as predicting variables towards accuracy of the billing systems.

1.2 Problem Statement:

The problems of this thesis are as follows:

- * Ensuring that telecommunication companies provide services at the same price and cost/charge, Quality in accurate way.
- * Determine the accuracy of Billing Systems in Sudanese Telecommunications companies (Op3 , Op2 ,OP1 ,and Op4) .

1.3 Research Questions:

- * How to Measure and Investigate the accuracy of Billing Systems in Sudanese Telecommunications companies (Op3,Op2, OP1,and Op4) ?

- * How to ensure that telecommunication companies provide services at the same price and cost/charge, Quality in accurate way?

1.4 Objectives:

The objectives of this thesis are as follows:

- * To design a system that generate Actual Reports from the voice calls, SMS etc price/cost/Quality to make comparisons between actual voice calls throw GSM and ordinary voice calls, SMS etc , throw Billing Systems that telecommunication companies generated.
- * Investigate the determinants the accuracy of Billing Systems in Sudanese Telecommunications companies (Op3 , Op2 ,OP1 and Op4).

1.5 Scope:

For the NTC (National Telecommunication Corporation) this Research project provides ability to Investigate the determinants accuracy of the Billing Systems in Sudanese Telecommunications companies (Op3 , Op2 ,OP1 and Op4).the work will be limited by the voice calls and SMS only.

1.6Thesis Layout:

Chapter one gives introduction about the project, defining the problem, objectives, methodology and scope. Chapter two contains two parts. Part one represents a general background about billing systems; part two is the related studies and billing systems techniques. Chapter three also contains two parts, first part explains the tools and techniques used in this project, and the second part is the UML design for the project functionality. Chapter four contains the project implementation. Chapter five is the results and recommendations.

CHAPTER 2
BACKGROUND TO BILLING
SYSTEMS

2.1 Introduction

This chapter is divided into two sections, the first section gives general description of billing System and its operation, the second section describes the related studies to research project.

2.2 Telecoms Billing Overview:

Telecoms Billing Systems process files of call data by matching each call against a customer record and rating it against a pricelist to produce a cost for each call[3].

The data often arrives from a third party as a daily or monthly data file known as a CDR (Call details Record) file this file usually contains one record for each call containing the following minimum level of information:

- * Number Dialed.
- * Originating Number (CLI which stands for Caller Line Identification) used to identify the customer.
- * Duration in seconds or tenths of a second.
- * Date and Time of the Call.

The billing process takes each call and first matches the originating number against the

Customer database to discover the customer and pricelist to apply for this call. Each call is then rated against the pricelist to produce a retail

price for the call. The pricelist contains the following parameters used to calculate the retail price [3]:

- * A retail price per second for the call.
- * The retail price may differ for standard, economy and weekend time zones.
- * A setup charge that is added to each call (some calls will have only a setup charge and no price per second).

They may be issues that prevent the matching and rating of an individual call. These problem calls are placed in a suspense file for the billing manager to look at. Each call in the suspense file may be flagged with a suspense code that illustrates the problem encountered. For example, there may be issues matching the originating number for a new line against a customer record because the number has not been entered into the customer database (part of a process known as provisioning).

Call Data records may come from different sources depending on the technical options employed by the reseller who may provide VOIP services with one supplier and traditional telecoms services through another.

Part of the job of a billing manager is to look at the suspense file regularly and then resolve any issues and reprocess the suspense files. Billing often takes place on a particular day each month and bills are produced for each customer only once all the calls in the suspense file have been re-rated or written off. Part of the billing process is to perform reconciliation where a number of bills are checked for accuracy and the totals for the month are checked against the telecoms provider invoice and validated against previous months to look out for any problems.

The actual billing run often involves the creation of an invoice and a data file containing the monthly call data for each customer. A summary may also be imported into the accounting system.

One final thing to note about billing is that it is often a monthly process that uses a call detail file created from a telecoms provider which itself has put the call details through their billing process. The provider may also provide a daily file or one may be available from local equipment (from an asterisk box or a local telecoms switch). It is important to monitor the daily files for fraud in case a customer's system has been compromised. Fraud can occur over a bank holiday where a phone system is compromised and used to set up a call shop over a weekend which can result in thousands of pounds of fraudulent calls being made. If no other process is available, the billing system might also be used for monitoring fraud by processing daily files although the actual customer bills might use the monthly call details file for producing the actual bills[3].

2.3 Preparation:

A good deal of preparation is required before a monthly billing run can be completed

successfully. It is possible to simply run a call details file through the billing system and

watch the entire call records drop into the suspense file which will provide a list of every action that needs to be performed to resolve billing issues for each call. A more efficient process is to prepare the following data for provisioning into the billing database [3]:

- * Customers need to be entered into the database together with details of any Originating Numbers to be used to match against the call detail records. Additional information may need to be

billed each month for rental of handsets and a maintenance fee or other system costs.

- * Pricelist information needs to be maintained for each destination called by the customer. The rating process should place calls to any destinations that do not have a valid retail price into the suspense file.
- * Many telecoms providers will include the cost information for each call in their call details record which can be used to double check that each call is being billed at a profit. An alternative is to create a pricelist for call costs and to rate each call for both retail and cost prices as part to aid the reconciliation process.
- * Call details may originate from different source each of which may have a different format. The pre-processing of each data file into a format that can be processed by the billing system is called mediation and needs to be set up by the technical team before billing can commence. This may also require the identification of additional information for a call such as whether it was a data or voice call.

2.4 Suspense:

A large part of the responsibility of a Billing Manager is to eliminate calls from the suspense file. Each of these calls represents a call that cannot be billed to a customer and therefore a potential loss of revenue. Some of these calls may be due to an error by the telecoms provider and a mechanism might be required to claw this money back from the provider if the call cannot be billed [3].

A variety of reasons can prevent a call being matched and rated successfully. Here are some of the typical suspense reasons that are encountered each month:

- * Missing CLI (Originating Number) where no match is found in the customer database.
- * Retail price of the call is less than the cost obtained using the cost pricelist or from the provider's cost data.
- * Invalid destination number.
- * Retail price not found in the database.

Each of these issues needs to be resolved and the suspense files re-rated ready for billing. The Billing Manager needs to clear all the suspense or write off the call records prior to completing the billing process.

2.5 Reconciliation:

The reconciliation process is usually performed by the Billing Manager, maybe together with the Accounts department, and involves a series of cross-checks to make sure that there have been no errors during this month's billing process[3].

Each company devises their own checks some of which might be taken from the list **below**:

- * A justification is required for each call written off in the suspense file and occasionally revenue needs to be reclaimed from the provider.
- * Each individual call might be checked against the actual cost charged by the provider or against a cost pricelist.
- * A percentage of the monthly bills for each customer should to be checked manually.
- * The monthly totals for each customer (minutes and value) should be checked against historical spending patterns to look for any discrepancy (or fraud).

- * Total duration and number of calls per destination can be checked against historical trends.
- * The total duration and number of calls can be checked against the provider's invoice and often broken down by destination.
- * Totals for items other than calls needs to be checked against historical trends both by customer and as totals by product type.

Reconciliation is critical to the billing process and any errors in billing needs to be identified before the bills are sent out to the customers. Sometimes the monthly billing run may need to be repeated (using a backup of the database) if a major error is encountered[3].

2.6 Billing:

The final stage in the billing process once reconciliation is complete is the creation of the customer bills and their fulfillment by sending out emails or importing data into the accounting system[3].

This final stage typically involves some or all of the following:

- * Creation and emailing of a spreadsheet and maybe a summary sheet or PDF containing call details for each customer.
- * Importing of billing information into the accounting system for the production of invoices.
- * Interfacing with a payment system (such as direct debit in the UK) for payment processing.

Billing is an endless cycle and processing of daily call details and suspense may continue

During the billing process or immediately once billing is complete in preparation for the next month of bills. Larger companies may need to stagger billing into a weekly process for different groups of customer to regulate the Billing Manager's workload or level out the cash flow[3].

2.7 Billing Types:

2.7.1 Pre-pay Billing: A billing mechanism where customer pays in advance and after that starts using a service. Usually, prepaid customers do not receive any invoice and they are charged in real time by the highly available billing systems called IN (Intelligent Network)[4].

2.7.2 Post-pay Billing: this is the conventional billing, which is used for many years. Here, customers byproducts and services and use them throughout the month, and by end of the month, invoices are generated by the service provider and sent those invoices to the customers to make their due payment [4].

2.7.3 Interconnect Billing: the network operator is usually financially responsible for services provided to its customers by other networks regardless of whether or not the customer pays for the service. Interconnect billing is related to inter-carrier or sometimes called partner settlements.

2.7.4 Roaming Charging: When a customer goes from one network operator's coverage area to another operator's coverage area, first operator would pay marginal charges to second operator to provide services to their customers. such type of charges is settled through roaming billing [4].

2.7.5 Convergent Billing: Convergent billing is the integration of all service charges onto a single customer invoice. Convergent billing means creating a unified view of the customer and all services (Mobile, Fixed, IP, etc.) provided to that customer [4].

Telecom Charging:

Telecom operators are charging their customers in various ways, but there are two mainly used parameters to charge a customer:

Rental Charges: These are the charges taken from the customers on monthly basis against a service provided. For example, your telephone monthly charges would be \$5.00 regardless you use it or not.

Usage Charges: These are the charges taken from the customers based on the service utilization. For example, you would be charged for all the calls made or data downloaded using your phone.

2.8 Related Studies:

- **Billing and Metering Accuracy of Public Telecommunications Services in Hong Kong Statement of the Telecommunications Authority Hong Kong (4 August 2000)**[\[5\]](#).

This Consultation Paper on Billing and Metering Accuracy of Public Telecommunications Services in Hong Kong which aimed to seek

industry's comments on a proposed Meter Approval Scheme (the proposed Scheme) to ensure the accuracy and integrity of the metering and billing systems of operators in the telecommunications industry. The consultation paper addressed the background, the needs and benefits and specific proposals on the implementation of the proposed Scheme.

Results:

Having considered the comments received, the TA (Telecommunications Authority) concludes that Metering Approval Scheme should be implemented in Hong Kong in order to enhance the confidence of the customers on billing accuracy of the industry. In order to ensure early implementation of the proposed Scheme, the TA decides that an industry forum shall be established shortly to work out details of the proposed Scheme including the metering and billing accuracy and integrity standard, self-appraising system, auditing system, monitoring system and implementation plan.

- **Telecom Regulatory Authority Of India (Expression of Interest for Empanelment of Auditors to certify the Metering and Billing System of Telecom Service Providers). December, 2013**[\[6\]](#).

The purpose of this study was to metering and defines the accuracy of billing system in Indian telecom companies.

- **Quality Assurance Manual for Billing and Metering Integrity Scheme (TELECOMMUNICATIONS AUTHORITY HONG KONG) (September 2000)**[\[7\]](#).

The purpose of this study was to investigate the Billing and Metering Integrity Standards and show Telecommunications Metering Acceptance Model , Telecommunications Billing Acceptance Model and Metering Tolerance , Billing Tolerance and Verification of Metering and Billing System, make Guidelines to Design Operator's Detailed Operation Manual and Monthly Test Report.

- **An Investigation into Telecommunications Billing System Testing Processes Vitesh J. Jinabhai, Rex van Olst School of Electrical and Information Engineering University of the Witwatersrand, Private Bag 3, Wits, 2050[8] .**

An investigation which examines the software testing processes of a telecommunications billing solutions provider is proposed. The process will be measured using metrics determined by the Goal Question Metric (GQM) approach.

Results:

The lack of adequate software testing is a costly issue, which can significantly impact a telecommunications company. This is especially true for billing systems. The proposed study aims to evaluate the software testing processes of a telecommunications billing solutions provider for improvement purposes. The outlined methodology uses the GQM approach to ensure that the process is measured effectively. Initial metrics focusing on defect detection and correction have been defined as a basis. The analysis of the results will focus on correlations between metrics themselves and metric types, allowing for improvements to be made.

- **Telecommunications Billing in the Competitive Wire line Area Hong Kong (May 2007)[9].**

This paper will begin with a review of the changing landscape of the Hong Kong wire line telecommunications market. It will discuss how competitive pressures affected the billing and operational support systems of local telecom companies and will conclude with thoughts on what the future holds for billing operations support systems, especially relating to development in next generation networks.

- **MS: Matti Swan Elisa Research : Total cost of charging and billing: CapEx and OpEx[[10](#)]:**

The purpose of this paper is to give an overview of charging and billing system costs in the area of telecommunications business. First, the structure of the billing and charging system is briefly explained. Estimates for capital (CAPEX) and operational (OPEX) expenditures will be presented as well as how billing requirements in wireless IP-based networks will affect these.

Results:

Charging and billing is a critical part of telecom service providers' operation to recover financial investments in the infrastructure and generating profits for shareholders. A failure or inaccuracy in collecting charging information from the network can cause the provider to lose a significant amount of money.

- **Smart Meters and Smart Meter Systems: A Metering Industry Perspective *An EEI-AEIC-UTC White Paper*[[11](#)].**

(March 2011).

This report was conducted with the oversight of the Edison Electric Institute (EEI) and Association of Edison Illuminating Companies (AEIC) Metering Committees and the Smart Meter Report Project Team.

- **Summary of previous studies:**

According to the above studies, it is noted that many countries in the world seek to control metering and define the accuracy of billing systems in

their telecom operators. Also these studies show convincing and excellent results which help the competent authority to take the necessary measures against telecom operators in the case of approving the inaccuracy of their billing systems. These excellent results motivate us to apply this system in NTC to measure and investigate the quality of billing systems in Sudanese telecom operators.

CHAPTER 3

WORK ENVIROMENT AND PROPOSED SYSTEM ANALYSIS

3.1 Introduction:

This chapter describes specification of devices, operating system, programming language, and techniques used to build the system. Then explain how the system works and then describes the system analysis using UML technology.

3.2 System Requirement specification

Processor	:	Pentium 4.
RAM	:	512 MB.
Hard Disk	:	400 GB.
NIC	:	one NIC D-Links.
Mother board	:	INTEL.
Operating system	:	Windows7.
Modem	:	GSM/Modem.
SIM Cards	:	Three SIM

3.3 Techniques used in the system:

3.3.1 GSM Technology:

Global System For Mobile Communication (GSM) is a globally accepted standard for digital cellular communication. GSM is the name of a standardization group established in 1982 to create a common European mobile

telephone standard that would formulate specifications for a pan-European mobile cellular radio system operating at 900 MHz it is estimated that many countries outside of Europe will join the GSM Partnership[13].

GSM was devised as a cellular system specific to the 900 MHz band, called "The Primary Band". The primary band includes two sub bands of 25 MHz each, 890 to 915 MHz and 935 MHz to 960 MHz. GSM-PLMN has allocated 124 duplex carrier frequencies over the following bands of operation.

- Uplink frequency band: 890 to 915 MHz (MS transmits, BTS receives).
- Downlink frequency band: 935 to 960 MHz (BTS transmits, MS receives).
- Carrier spacing: 200 KHz.

3.3.1.1 Architecture of the GSM network:

A GSM network is composed of several functional entities, whose functions and interfaces are specified. Figure 1 shows the layout of a generic GSM network. The GSM network can be divided into three broad parts. The Mobile Station is carried by the subscriber. The Base Station Subsystem controls the radio link with the Mobile Station. The Network Subsystem, the main part of which is the Mobile services Switching Center (MSC), performs the switching of calls between the mobile users, and between mobile and fixed network users. The MSC also handles the mobility management operations. The Mobile Station and the Base Station Subsystem communicate across the Um interface (the air interface for the GSM mobile

telephone standard), also known as the air interface or radio link. The Base Station Subsystem communicates with the Mobile services Switching Center across the A interface(interface between the GSM BSC and the GSM MSC) [13].

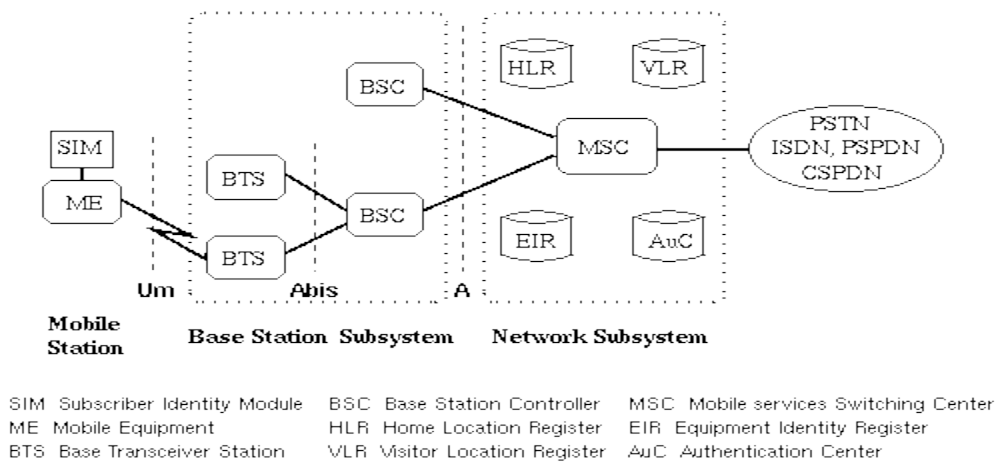

Figure (3.1) General architecture of a GSM network.

3.3.1.2 Mobile Station:

The mobile station (MS) consists of the mobile equipment (the terminal) and a smart card called the Subscriber Identity Module (SIM). The SIM provides personal mobility, so that the user can have access to subscribed services irrespective of a specific terminal. By inserting the SIM card into another GSM terminal, the user is able to receive calls at that terminal, make calls from that terminal, and receive other subscribed services [6].

The mobile equipment is uniquely identified by the International Mobile Equipment Identity (IMEI). The SIM card contains the International Mobile Subscriber Identity (IMSI) used to identify the subscriber to the system, a secret key for

authentication, and other information. The IMEI and the IMSI are independent, thereby allowing personal mobility. The SIM card may be protected against unauthorized use by a password or personal identity number.

3.3.1.3 Base Station Subsystem:

The Base Station Subsystem is composed of two parts, the Base Transceiver Station (BTS) and the Base Station Controller (BSC). These communicate across the standardized Abis interface (which is responsible for transmitting traffic and signaling information between the GSM BSC and the GSM BTS), allowing (as in the rest of the system) operation between components made by different suppliers [[14](#)].

The Base Transceiver Station houses the radio transceivers that define a cell and handles the radio-link protocols with the Mobile Station. In a large urban area, there will potentially be a large number of BTSs deployed, thus the requirements for a BTS are ruggedness, reliability, portability, and minimum cost.

The Base Station Controller manages the radio resources for one or more BTSs. It handles radio-channel setup, frequency hopping, and handovers. The BSC is the connection between the mobile station and the Mobile service Switching Center (MSC).

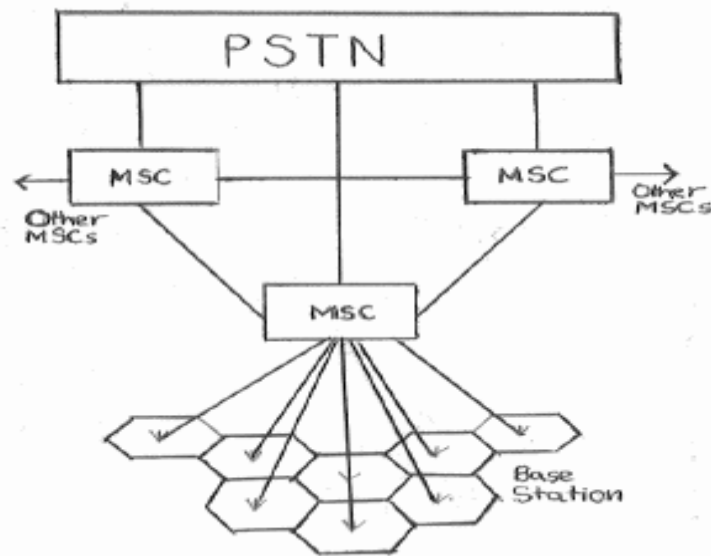

Figure (3.2) Mobile Switching Center.

3.3.1.4 Network Subsystem

The central component of the Network Subsystem is the Mobile services Switching Center (MSC). It acts like a normal switching node of the PSTN or ISDN, and additionally provides all the functionality needed to handle a mobile subscriber, such as registration, authentication, location updating, handovers, and call routing to a roaming subscriber. The MSC provides the connection to the fixed networks (such as the PSTN or ISDN). Signaling between functional entities in the Network Subsystem uses Signaling System Number 7 (SS7), used for trunk signaling in ISDN and widely used in current public networks [14].

The Home Location Register (HLR) and Visitor Location Register (VLR), together with the MSC, provide the call-routing and roaming capabilities of GSM. The HLR contains all the administrative information of each subscriber

registered in the corresponding GSM network, along with the current location of the mobile. The location of the mobile is typically in the form of the signaling address of the VLR associated with the mobile station. There is logically one HLR per GSM network, although it may be implemented as a distributed database.

3.3.2 GSM Modem:

Global System for Mobile Communications (GSM) modems are specialized types of modems that operate over subscription based wireless networks, similar to a mobile phone. A GSM modem accepts a Subscriber Identity Module (SIM) card, and basically acts like a mobile phone for a computer. Such a modem can even be a dedicated mobile phone that the computer uses for GSM network capabilities [14].

Traditional modems are attached to computers to allow dial-up connections to other computer systems. A GSM modem operates in a similar fashion, except that it sends and receives data through radio waves rather than a telephone line. This type of modem may be an external device connected via a Universal Serial Bus (USB) cable or a serial cable. More commonly, however, it is a small device that plugs directly into the USB port or card slot on a computer or laptop.

A GSM modem is a generic communication device just like its wired ancestors, but since the service is subscription-based, it must have a SIM card installed. This card connects the modem to the proper provider and identifies the user of the device to the carrier network. In this way, the GSM modem operates just like a cellular phone; in fact, many cellular phones also use SIM cards for the same purpose. Since the SIM card actually contains all the subscription, membership, and

user data, these cards are usually interchangeable between GSM modems and GSM cell phones.

- In This project is used GSM modem contains a single SIM Cards that represents one of the four telecommunications companies (Op3,Op2, OP1 , Op4) .The test will be according to the selected company.



Figure (3.3) shows GSM Modem.

3.3.3SIMCard:

A subscriber Identity `Module (SIM) card is a portable memory chip used mostly in cell phones that operate on the Global System for Mobile Communications (GSM) network. These cards hold the personal information of the account holder, including his or her phone number, address book, text messages, and other data. When a user wants to change phones, he or she can usually easily remove the card from one handset and insert it into another. SIM cards are convenient and popular with many users, and are a key part of developing cell phone technology [14].

3.3.3.1 Activating a SIM Card:

Since all of a user's data is tied to the SIM card, only it needs to be activated when the person opens an account with a cell phone service provider (also called a carrier). Each card has a unique number printed on the microchip, which the carrier needs to activate it. In most cases, the phone's owner can go either to the carrier's website and enter this number in the appropriate tool or call the service provider directly from another phone to get it turned on. SIM cards are tied to a particular carrier and can only be used with a service plan from that carrier [14].

3.3.4 .Net Framework:

The .NET Framework is an application development platform that provide services for building, deploying, and running desktop, web, and phone applications and web services. It consists of the common language runtime (CLR), which provides memory management and other system services, and an extensive class library, which includes tested, reusable code for all major areas of application development[15].

3.3.5 C# Programming Language:

C# (pronounced "See Sharp") is a simple, modern, object-oriented, and type-safe programming language. C# has its roots in the C family of languages and will be immediately familiar to C, C++, and Java programmers. C# is standardized by ECMA International as the **ECMA-334** standard and by ISO/IEC as the **ISO/IEC 23270**

Standard. Microsoft's C# compiler for the .NET Framework is a conforming implementation of both of these standards C# is an object-oriented language, but C# further includes support for **component-oriented** programming. Contemporary software design increasingly relies on software components in the form of

self-contained and self-describing packages of functionality. Key to such components is that they present a programming model with properties, methods, and events; they have attributes that provide declarative information about the component, and they incorporate their own documentation. C# provides language constructs to directly support these concepts, making C# a very natural language in which to create and use software components[16].

3.3.6 Crystal Report:

Crystal Reports is a popular Windows-based report writer (report generation program) that allows a programmer to create reports from a variety of data sources with a minimum of written code. Developed by Seagate Software, Crystal Reports can access data from most widely-used databases and can integrate data from multiple databases within one report using Open Database Connectivity (ODBC) [9].

3.3.7 SQL Server 2012:

Microsoft SQL Server 2012 is a relational database management system (RDBMS) designed for the enterprise environment. Like its predecessors, SQL Server 2012 comprises a set of programming extensions to enhance the Structured Query Language (SQL), a standard interactive and programming language for getting information from and updating database.

3.3.8 UML technology:

Unified Modeling Language (UML) is the industry standard language for describing, visualizing, and documenting object-oriented (OO) systems. UML is a collection of a variety of diagrams for differing purposes. Each type of diagram models a particular aspect of OO design in an easy to understand, visual manner. The UML standard specifies exactly how the diagrams are to be drawn and what each component in the

diagram means. UML is not dependent on any particular programming language, instead it focuses on the fundamental concepts and ideas that model a system. Using UML enables anyone familiar with its specifications to instantly read and understand diagrams drawn by other people[17]. There are UML diagram for modeling static class relationships, dynamic temporal interactions between objects, the usages of objects, the particulars of an implementation, and the state transitions of systems. In general, a UML diagram consists of the following features:

- 1. Entities:** These may be classes, objects, users or systems behaviors.
- 2. Relationship Lines:** that models the relationships between entities in the system.
- 3. Generalization:** a solid line with an arrow that points to higher abstraction of the present item.
- 4. Association:** a solid line that represents that one entity uses another entity as part of its behavior.
- 5. Dependency:** a dotted line with an arrowhead that shows some entity depends on the behavior of another entity.

3.4 How The System Works:

This section shows how the system works and includes the explanation stages of call generation and receiving call from the caller side through the GSM/Modem (which is considered as the core of the system that contains all required operations to generate and receive calls) to the call receiver side.

To describe the way system works, it is important to know about GSM/modem commands.

3.4.1 GSM/Modem Commands:

AT commands are instructions used to control a modem. AT is the abbreviation of Attention. Every command line starts with "AT" or "at". That's why modem commands are called AT commands. Many of the commands that are used to control wired dial-up modems, such as ATD (Dial), ATA (Answer), ATH (Hook control) and ATO (Return to online data state), are also supported by GSM/GPRS (General packet radio service) modems and mobile phones. Besides this common AT command set, GSM/GPRS modems and mobile phones support an AT command set that is specific to the GSM technology, which includes SMS-related commands like AT+CMGS (Send SMS message), AT+CMSS (Send SMS message from storage), AT+CMGL (List SMS messages) and AT+CMGR (Read SMS messages)[[18](#)].

There are some of the tasks that can be done using AT commands with a GSM/GPRS modem or mobile phone includes:

- Get basic information about the mobile phone or GSM/GPRS modem. For example, name of manufacturer (AT+CGMI), model number (AT+CGMM), IMEI number (International Mobile Equipment Identity) (AT+CGSN) and software version (AT+CGMR).
- Get basic information about the subscriber. For example, MSISDN (AT+CNUM) and IMSI number (International Mobile Subscriber Identity) (AT+CIMI).
- Get the current status of the mobile phone or GSM/GPRS modem. For example, mobile phone activity status (AT+CPAS), mobile network registration status (AT+CREG), radio signal strength (AT+CSQ), battery charge level and battery charging status (AT+CBC).

- Establish a data connection or voice connection to a remote modem (ATD, ATA, etc).
- Send and receive fax (ATD, ATA, AT+F*).
- Send (AT+CMGS, AT+CMSS), read (AT+CMGR, AT+CMGL), write (AT+CMGW) or delete (AT+CMGD) SMS messages and obtain notifications of newly received SMS messages (AT+CNMI).
- Read (AT+CPBR), write (AT+CPBW) or search (AT+CPBF) phonebook entries.
- Perform security-related tasks, such as opening or closing facility locks (AT+CLCK), checking whether a facility is locked (AT+CLCK) and changing passwords (AT+CPWD). (Facility lock examples: SIM lock [a password must be given to the SIM card every time the mobile phone is switched on] and PH-SIM lock [a certain SIM card is associated with the mobile phone. To use other SIM cards with the mobile phone, a password must be entered.])
- Control the presentation of result codes / error messages of AT commands. For example, you can control whether to enable certain error messages (AT+CMEE) and whether error messages should be displayed in numeric format or verbose format (AT+CMEE=1 or AT+CMEE=2).
- Get or change the configurations of the mobile phone or GSM/GPRS modem. For example, change the GSM network (AT+COPS), bearer service type (AT+CBST), radio link protocol parameters (AT+CRLP), SMS center address (AT+CSCA) and storage of SMS messages (AT+CPMS).

- Save and restore configurations of the mobile phone or GSM/GPRS modem. for example, save (AT+CSAS) and restore (AT+CRES) settings related to SMS messaging such as the SMS center address.

3.4.1.1 Basic Commands and Extended Commands:

There are two types of AT commands: basic commands and extended commands.

- Basic commands are AT commands that do not start with "+". for example, D (Dial), A (Answer), H (Hook control) and O (Return to online data state) are basic commands.
- Extended commands are AT commands that start with "+". All GSM AT commands are extended commands. for example, +CMGS (Send SMS message), +CMSS (Send SMS message from storage), +CMGL (List SMS messages) and +CMGR (Read SMS messages) are extended commands.

3.4.2 Setup and Verify The GSM Modem:

To test a GSM modem first connects the modem to the host system of Device manager using the documentation provided with the corresponding GSM modem. Once it is connected properly be sure to install the latest drivers compatible with the operating system that the host system of Device Manager is running on. The driver should be available from the manufacturer of the modem and will ensure that the host system is able to connect properly to the modem. once the modem is properly connected to the system with the latest compatible driver installed, the modem should be mapped to a COM port on the system. To determine which COM port the

modem is mapped to you will need to navigate to the system's 'Device Manager' by using the below steps (note this is from a Windows7system).

'Start Menu' => 'Control Panel' => 'System and Security' => 'System' => 'Device Manager' (see figure (A.4) in appendix A).

- Next if the modem is recognized properly it should be found in the 'Modems' section of the available hardware components shown in the Device Manager screen. Click on the 'Modems' section to expand the available modems. If for some reason your modem is not recognized it may still be mapped to a COM port within the 'Ports (COM & LPT)' section so try expanding that option and see if a COM port is available. Please note that if the GSM modem is a serial modem then it is most likely in COM1 or whichever port the serial port you connected the modem to is on. Once you find the option you believe to be the modem, right-click on it and select 'properties'. Within the properties screen select the 'Modem' tab and there you should see what port the modem is mapped to as well as the 'Maximum Port Speed' (baud rate). Generally the baud rate is 115200.

- After setup and verifying the modem the next step is identifying of (see figure (A.5) in appendix A) :

- 1- **Port Name:** The Port property specifies the serial port or the virtual serial port of the computer to which the GSM Modem or Phone is connected.

- 2- **Baud Rate:** The Baud Rate property specifies the baud rate at which the connected GSM Modem or Phone communicates with the computer.

3- **Data Bits:** The Data Bits property specifies the communication Data Bits size between GSM Modem or Phone and the computer

4- **Parity:** The Parity property specifies the type of parity check for communication between GSM Modem or Phone and the computer.

5- **Stop Bits:** The Stop Bits property specifies the communication Stop Bits size between GSM Modem or Phone and the computer.

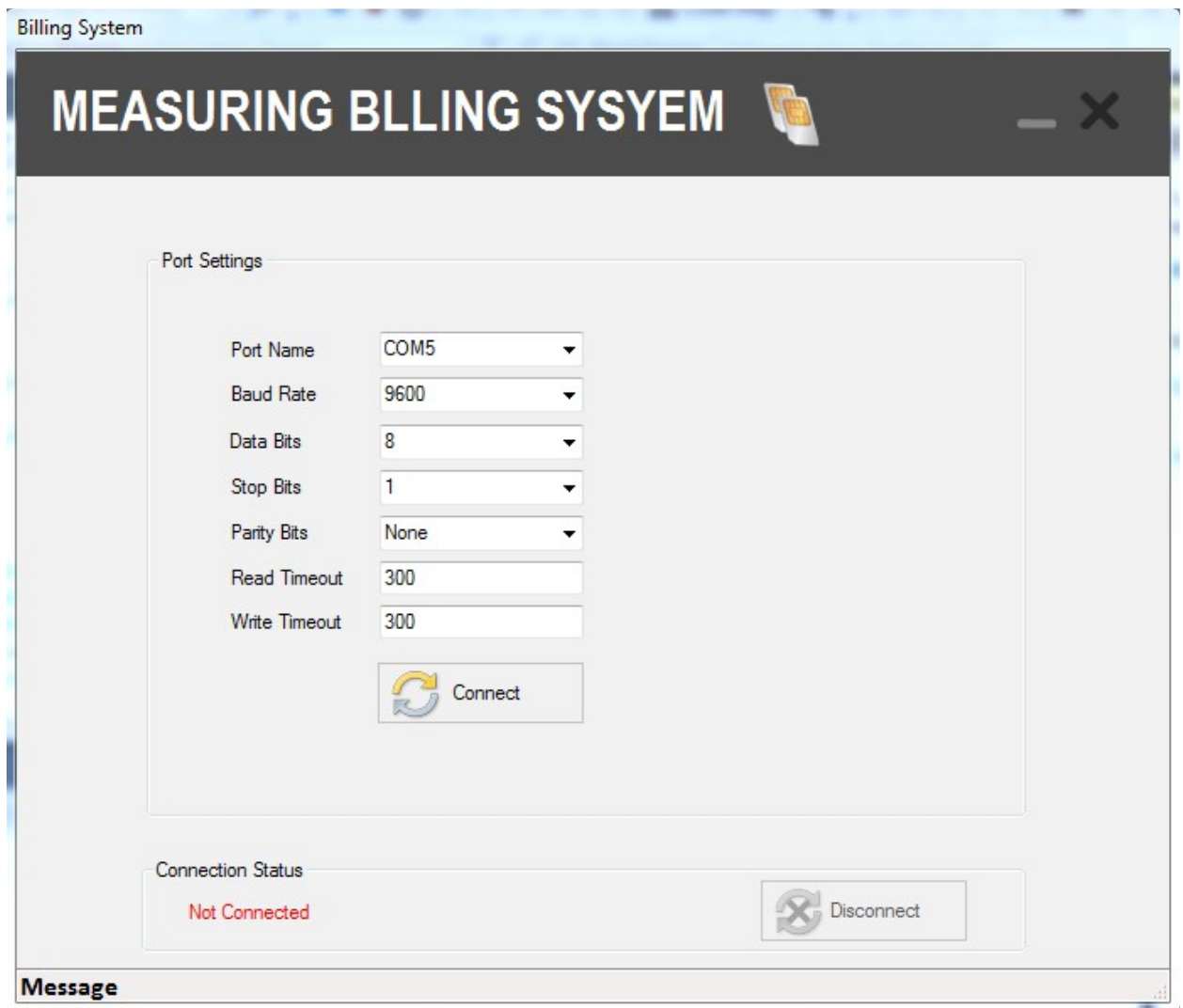

Figure (4.3) shows setup GSM Modem in the system.

3.4.3 Identifying of call duration:

This step is to determine the call duration once answering the call in receive call side (the call duration was calculated in MS).

- The System depends on receiving call side (RCS) to calculate the real call duration instead of outgoing call side (OCS), because RCS gives accurate results, once the receiver pick up the call, the counter will be start and calculate the accurate and real duration, the counter will be stop work when hanging up the call, unlike the OCS does' give accurate results because the counter of call duration will be start once outgoing call start countering before answering call in RCS.

3.4.4 Determining the Price List:

After determined the duration of call, the next step is to determining the price list of call. The price list is process of identifying the tariff or price for each call duration according to selected telecom company (OP3, OP1, OP2 and OP4), because each telecom company has its own specific policies in price list.

3.4.5 Receiving call:

This step play an important role in implementation of the system, before pick up the call we identify the connected port, and using ATA command to answer the call, once picking up operation done the counter and timer will start with in picking up of call in accurate way. Then the timer will stop after hanging up of call, then calculating the call cost.

3.4.6 Calculating Call Cost:

After answering and hanging up the call, this step is to calculate the accurate cost of call according to specified price and call duration, which were mentioned previously, by multiplying the call duration in selected price to generate the total cost of call. In this part once all operations completed the following data will automatically be saved to database:

- Serial number of call.
- The Duration of call.
- The total cost of call.
- The price of call.
- The Call start and end time.
- Caller number.
- Receiver call number.
- The date of the call.

3.4.7 Generating Reports:

Generating reports is the most important part of the system, which is considered as a core part of this research. Once this information (Serial number of call, Duration of call, total cost of call, price of call, price of call, Caller number, Receiver call number, date of the call) has been saved successfully to the data base, they are used to generate the reports using SQL Server (2012) and Crystal report technologies.

3.5 System Analysis:

3.5.1 Use Case Diagram:

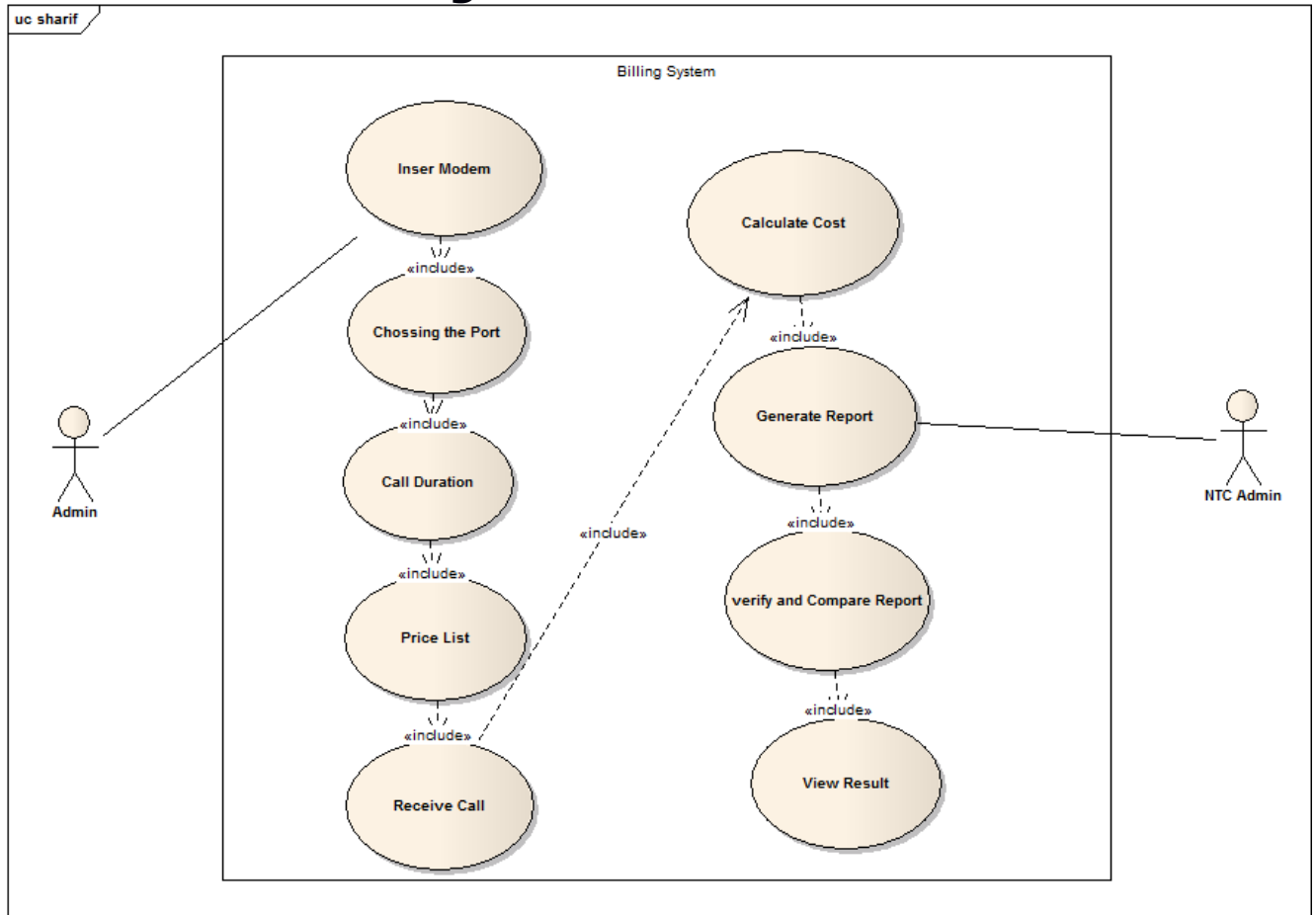

Figure (3.4) Use Case Diagram for the system.

3.5.2 Sequence Diagram:

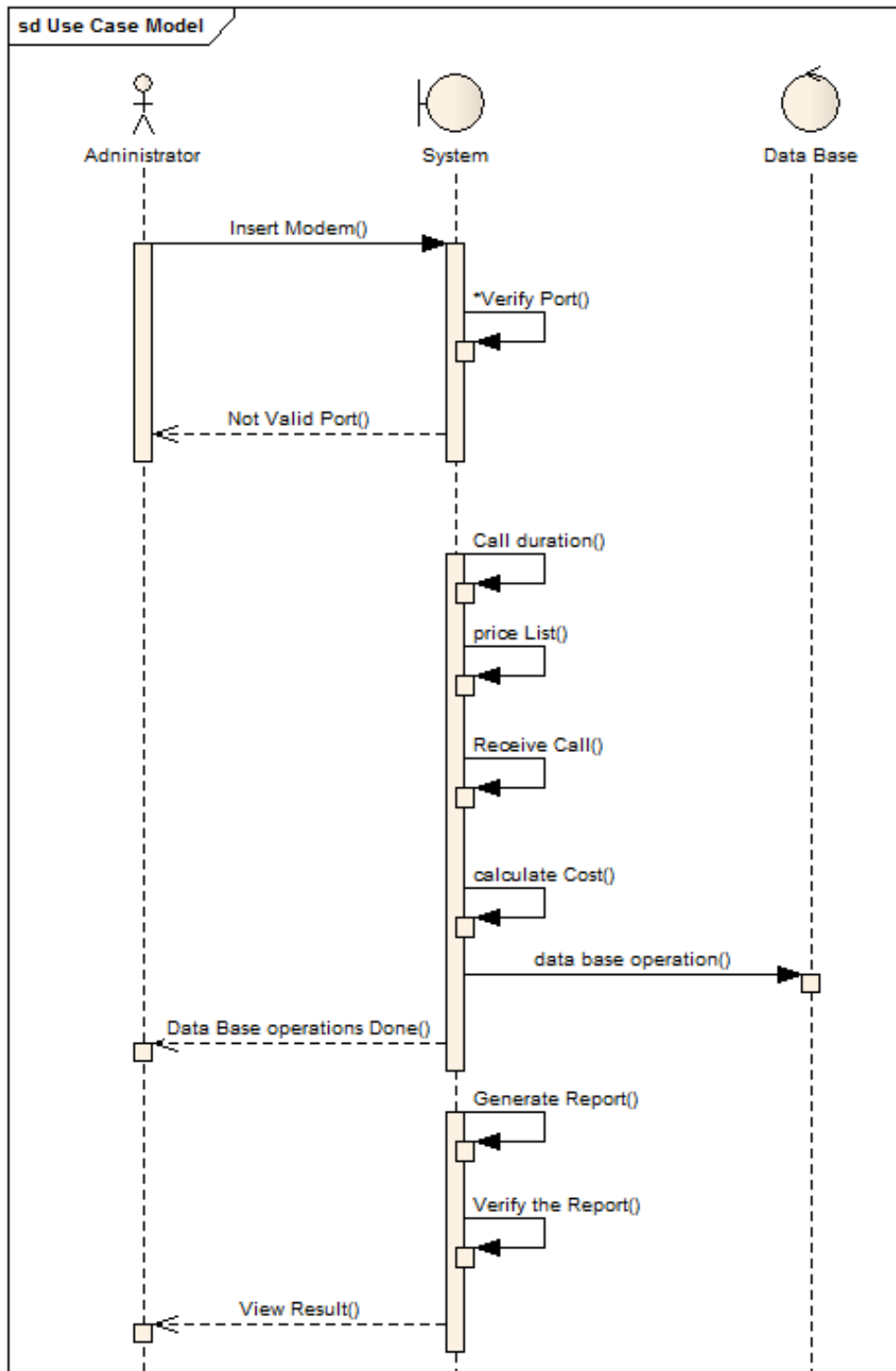

Figure (3.5) Sequence Diagram for Administrator Side

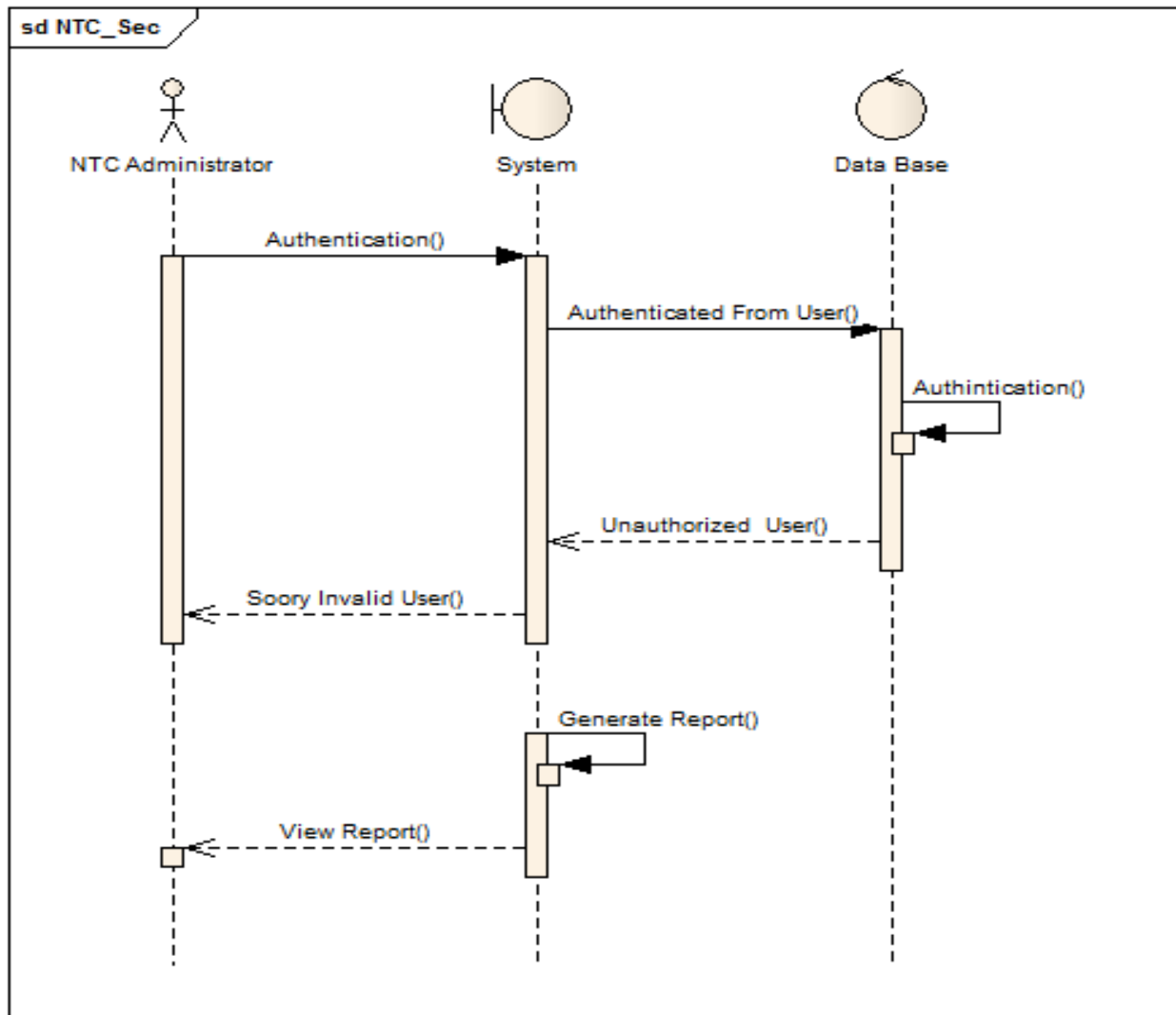

Figure (3.6) Sequence Diagram for NTC Side.

3.5.3 Activity Diagram:

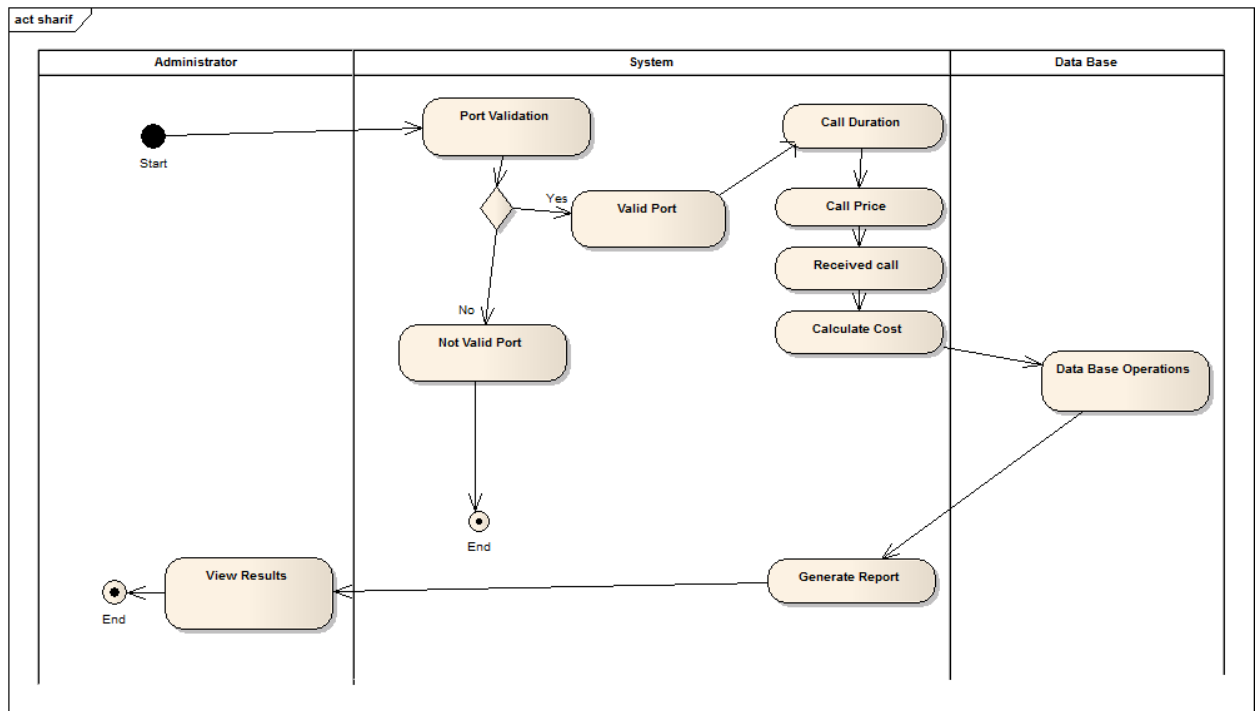

Figure (3.7) Activity Diagram for System.

CHAPTER 4

RESULTS AND

DISCUSSION

4.1 Introduction:

This chapter is divided into two sections, the first section discusses the final results of the System, and the second section discusses the recommendations and conclusion.

4.2 Results:

The final results depend on two factors:

- Metering of call which is the start and end time of call.

- The cost of call which is the final total cost of the call.

4.2.1 Metering and Cost of call:

The metering and cost methods used to investigate and compare the accuracy of cost and time (start and end time of call) of call by comparing the generated cost and time of call in my system, and the cost and time of call in telecommunication companies (Op3, OP1, Op2 and Op4) using crystal report technology.

From To	OP3	OP1	OP2
OP3	0.0022	0.003166	0.003166
OP1	0.003	0.003	0.003
OP2	0.003	0.003	0.003

The above table shows the tariff of calls between the various telecom operators.

4.2.1.1 Metering and Cost of Call inside OP1 Telecom Company:

The test includes the on-net (the call inside OP1) and off-net (the call outside OP1).

4.2.1.1.1OP1 On-Net Calls:

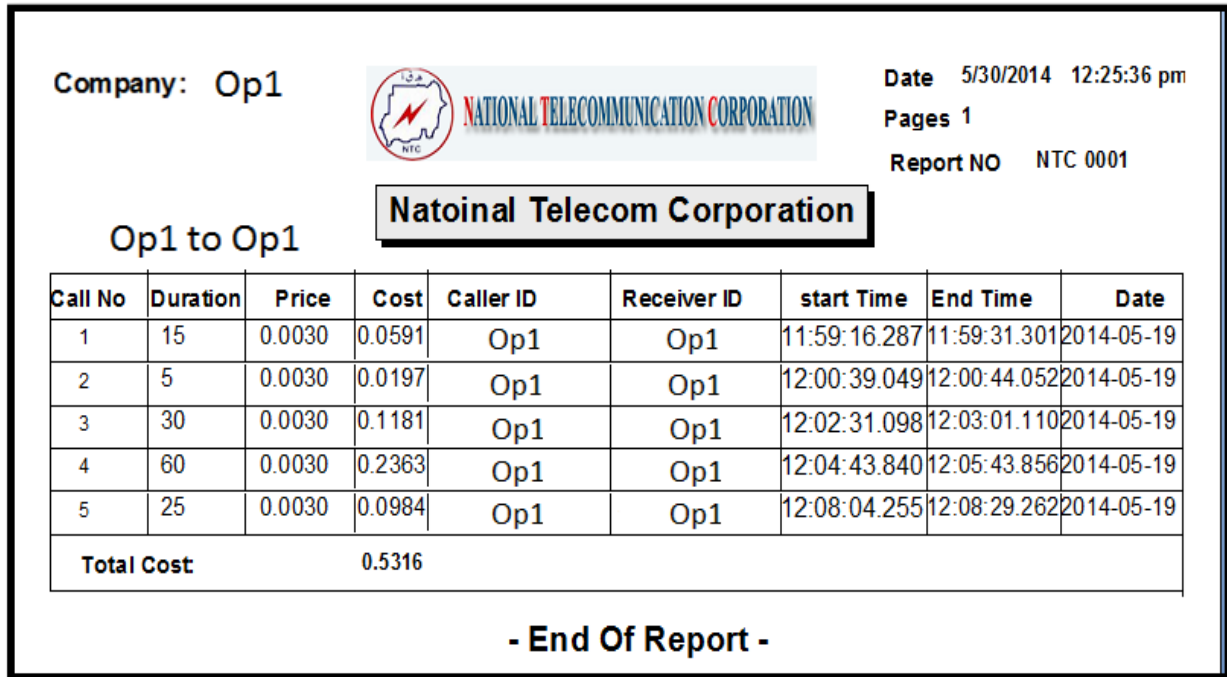

Figure (4.1) the system results inside OP1 (on-net).

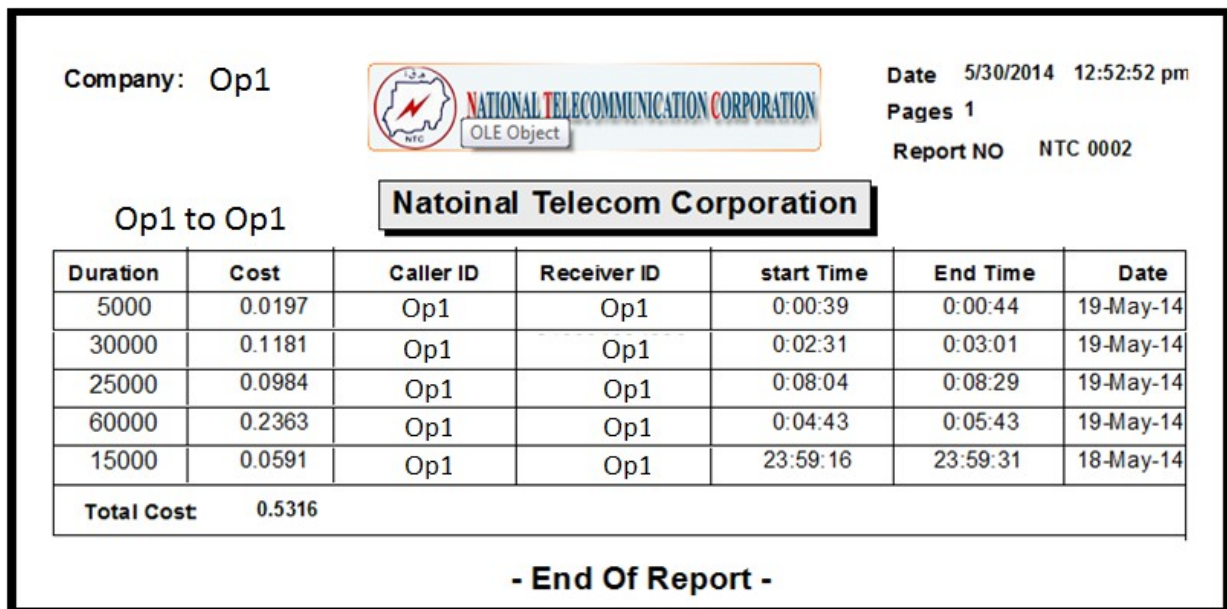

Figure (4.2) the Originalon-net OP1 results.

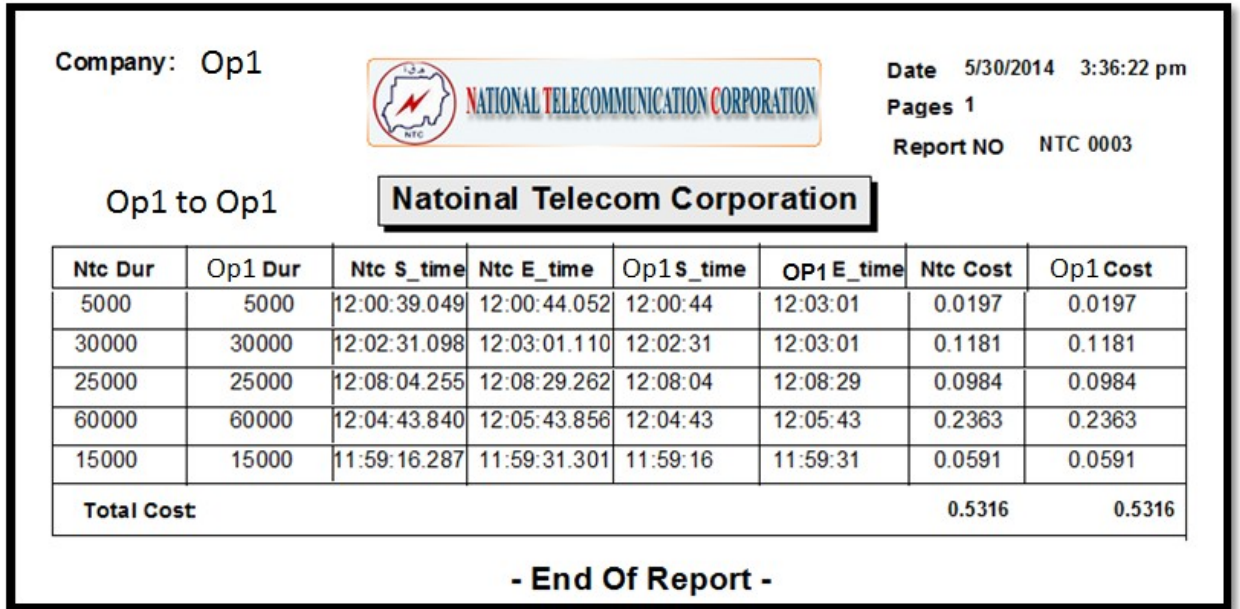

Figure (543) comparing results between OP1 and System.

- **Note:**
- NTC_Dur refers to The System Duration.
- NTC_S-time refers to the system's Start Time of call.
- NTC_E-time refers to the system's Start Time of call.
- NTC_Cost refers to the systems cost.

Figure (4.4) comparing cost when calling from OP1 to OP1 using Graph.

- According to above reports and graph the results shows that the cost is accurate and stable (correctly billing), also the time of call (start and end time of call) is accurate (correctly metering) but not in milliseconds in OP1 side.
- The graph above explains that no different in cost.

4.2.1.1.2OP1 Off-Net Calls:

The off-net side includes the calls outside OP1 telecom Company (Op3 and Op2 telecom companies).

- **Firstly OP1 to Op3 Telecom :**

Company: Op1		 NATIONAL TELECOMMUNICATION CORPORATION		Date 5/30/2014 4:10:43 pm				
				Pages 1				
				Report NO NTC 0002				
Op1 to Op3		Natoinal Telecom Corporation						
Call No	Duration	Price	Cost	Caller ID	Receiver ID	start Time	End Time	Date
27	10	0.0030	0.0394	Op1	Op3	07:58:27.840	07:58:37.856	2014-05-19
28	20	0.0030	0.0788	Op1	Op3	07:59:08.026	07:59:28.041	2014-05-19
29	30	0.0030	0.1181	Op1	Op3	08:00:12.922	08:00:42.937	2014-05-19
30	60	0.0030	0.2363	Op1	Op3	08:01:27.631	08:02:27.644	2014-05-19
32	5	0.0030	0.0197	Op1	Op3	08:02:56.255	08:03:01.262	2014-05-19
Total Cost:			0.4923					
- End Of Report -								

Figure (4.5) the system results From OP1 to Op3telecom.



Company: Op1		 NATIONAL TELECOMMUNICATION CORPORATION		Date 5/30/2014 3:51:11 pm		
				Pages 1		
				Report NO NTC 0002		
Op1 to Op3		Natoinal Telecom Corporation				
Duration	Cost	Caller ID	Receiver ID	start Time	End Time	Date
30000	0.1181	Op1	Op3	8:00:25	8:00:55	19-May-2014
10000	0.0394	Op1	Op3	7:58:40	7:58:50	19-May-2014
20000	0.0788	Op1	Op3	7:59:20	7:59:40	19-May-2014
60000	0.2363	Op1	Op3	8:01:40	8:02:40	19-May-2014
5000	0.0197	Op1	Op3	8:03:09	8:03:14	19-May-2014
Total Cost:		0.4922				
- End Of Report -						

Figure (4.6) theOriginal results FromOP1 to Op3 telecom.

Company: Op1				Date 5/30/2014 4:45:15 pm			
Op1 to Op3				Pages 1			
				Report NO NTC 0003			
Ntc Dur	Op1 Dur	Ntc S_time	Ntc E_time	Op1 S_time	OP1 E_time	Ntc Cost	Op1Cost
30000	30000	08:00:12.922	08:00:42.937	8:00:25	8:00:55	0.1181	0.1181
10000	10000	07:58:27.840	07:58:37.856	7:58:40	7:58:50	0.0394	0.0394
20000	20000	07:59:08.026	07:59:28.041	7:59:20	7:59:40	0.0788	0.0788
60000	60000	08:01:27.631	08:02:27.644	8:01:40	8:02:40	0.2363	0.2363
5000	5000	08:02:56.255	08:03:01.262	8:03:09	8:03:14	0.0197	0.0197
Total Cost						0.4923	0.4922

- End Of Report -

Figure (4.7) comparing results between OP1 to Op3 and the System (OP1 to Op3).

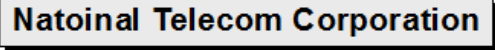
Figure (4.8) comparing cost when calling from OP1 to Op3 via Graph using the system total cost and OP1 total cost.

- The results show that the cost of call is accurate (correctly bill) and the time (start and end time of call) is also accurate (correctly metering) when calling from OP1 to Op3telecom, also the graph explains the accuracy of cost (no different in cost).

- **Secondly OP1 to Op2 Telecom :**

Company: Op1		 NATIONAL TELECOMMUNICATION CORPORATION		Date 5/30/2014 5:12:28 pm				
Op1 to Op2				Pages 1				
				Report NO NTC 0002				
				Natoinal Telecom Corporation				
Call No	Duration	Price	Cost	Caller ID	Receiver ID	start Time	End Time	Date
2	10	0.0030	0.0394	Op1	Op2	06:35:45.458	6:35:55.47	2014-05-18
4	30	0.0030	0.1181	Op1	Op2	06:54:18.656	6:54:48.67	2014-05-18
5	60	0.0030	0.2363	Op1	Op2	07:00:01.120	7:01:01.13	2014-05-18
6	5	0.0030	0.0197	Op1	Op2	07:03:17.353	7:03:22.36	2014-05-18
7	120	0.0030	0.4725	Op1	Op2	11:39:50.840	1:41:50.85	2014-05-18
Total Cost			0.8860					

- End Of Report -

Figure (4.9) the system results From OP1 to Op2 telecom

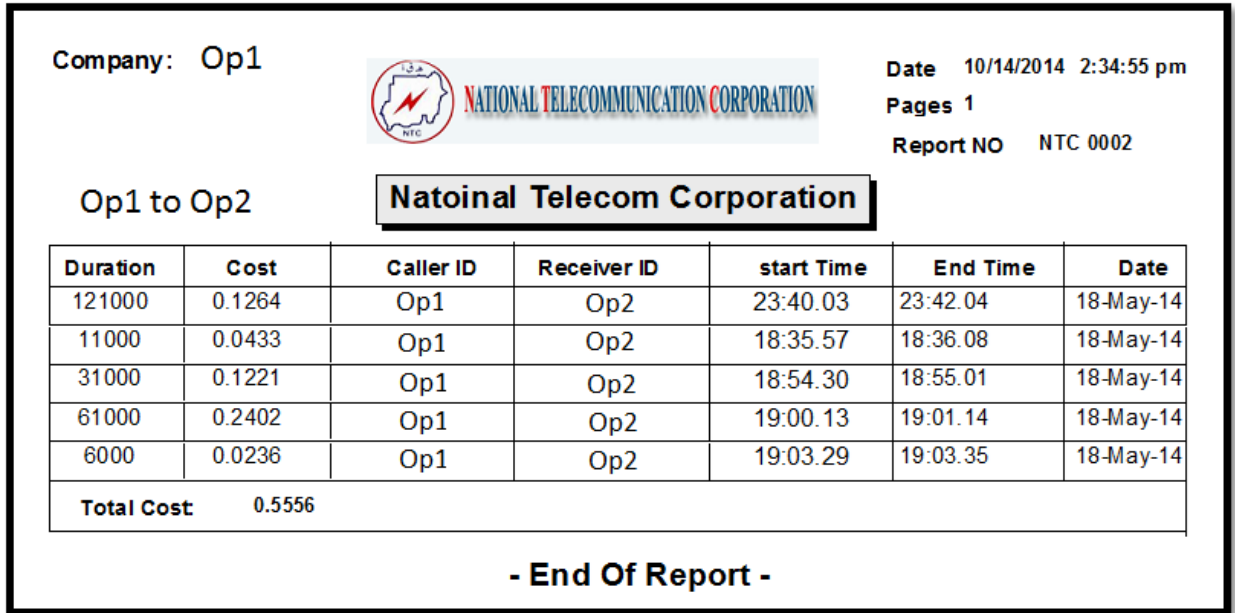

Figure (4.10) the Original results From OP1 to Op2s telecom.

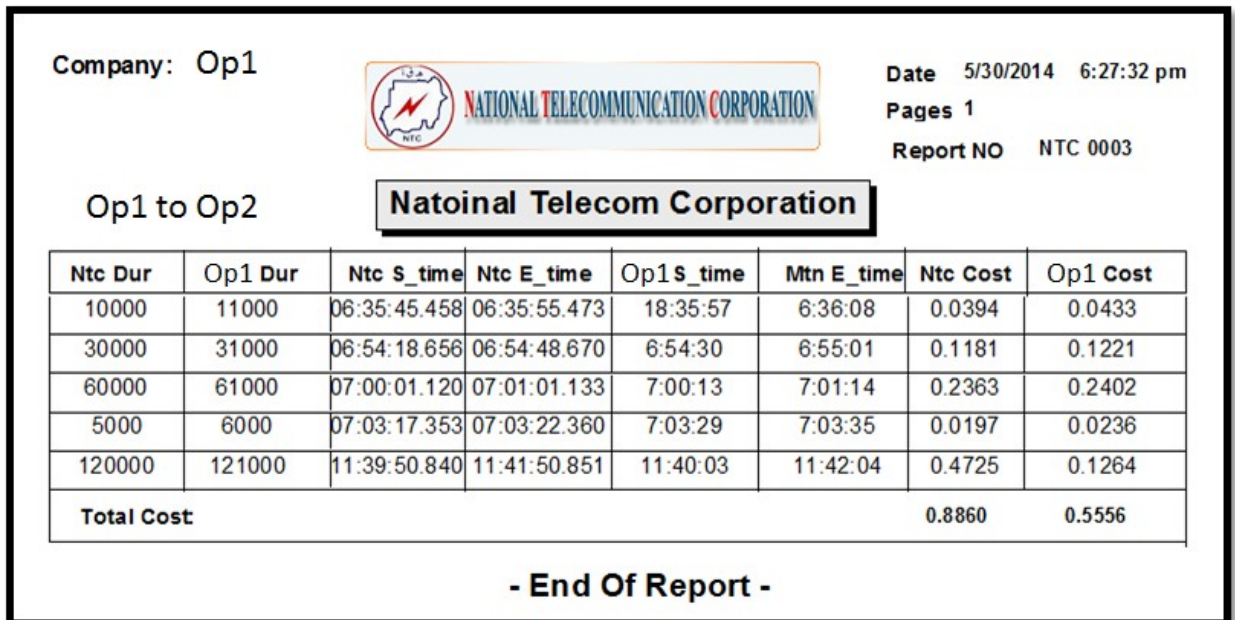

Figure (4.11) comparing results between OP1 to Op2 and the System(OP1 to Op2)

Figure (4.12) comparing cost when calling from OP1 to Op2 via Graph using the system total cost and OP1 total cost.

- The results show that the cost of call is not accurate (over bill) and the time (start and end time of call) is also not accurate (over metering) when calling from OP1 to Op2 telecom.

4.2.1.2 Metering and Cost of Call inside Op2 Telecom Company:

Also the test includes the on-net (the call inside Op2) and off-net (the call outside Op2).

4.2.1.2.1 Op2 On-Net Calls:

Company: Op2		 NATIONAL TELECOMMUNICATION CORPORATION		Date 6/1/2014 10:00:55 pm				
Op2 to Op2				Pages 1				
		Natoinal Telecom Corporation		Report NO NTC 0002				
Call No	Duration	Price	Cost	Caller ID	Receiver ID	start Time	End Time	Date
8	5	0.0030	0.0197	Op2	Op2	12:45:52.096	12:45:57.10	2014-05-19
9	15	0.0030	0.0591	Op2	Op2	12:47:09.799	12:47:24.80	2014-05-19
10	60	0.0030	0.2363	Op2	Op2	12:47:54.228	12:48:54.24	2014-05-19
11	80	0.0030	0.3150	Op2	Op2	12:49:32.493	12:50:52.49	2014-05-19
12	2	0.0030	0.0079	Op2	Op2	12:52:12.867	12:52:14.88	2014-05-19
Total Cost:			0.6380					
- End Of Report -								

Figure (4.13) the system results from Op2 to Op2 telecom.

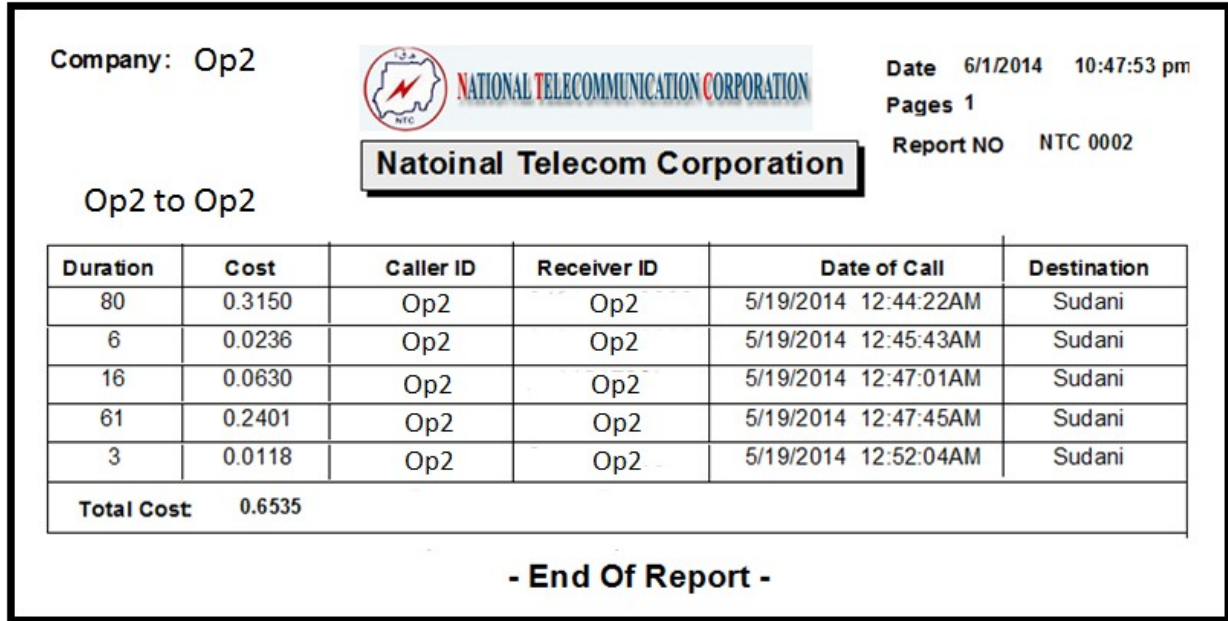

Figure (4.14) the Original results From Op2 to Op2 telecom.

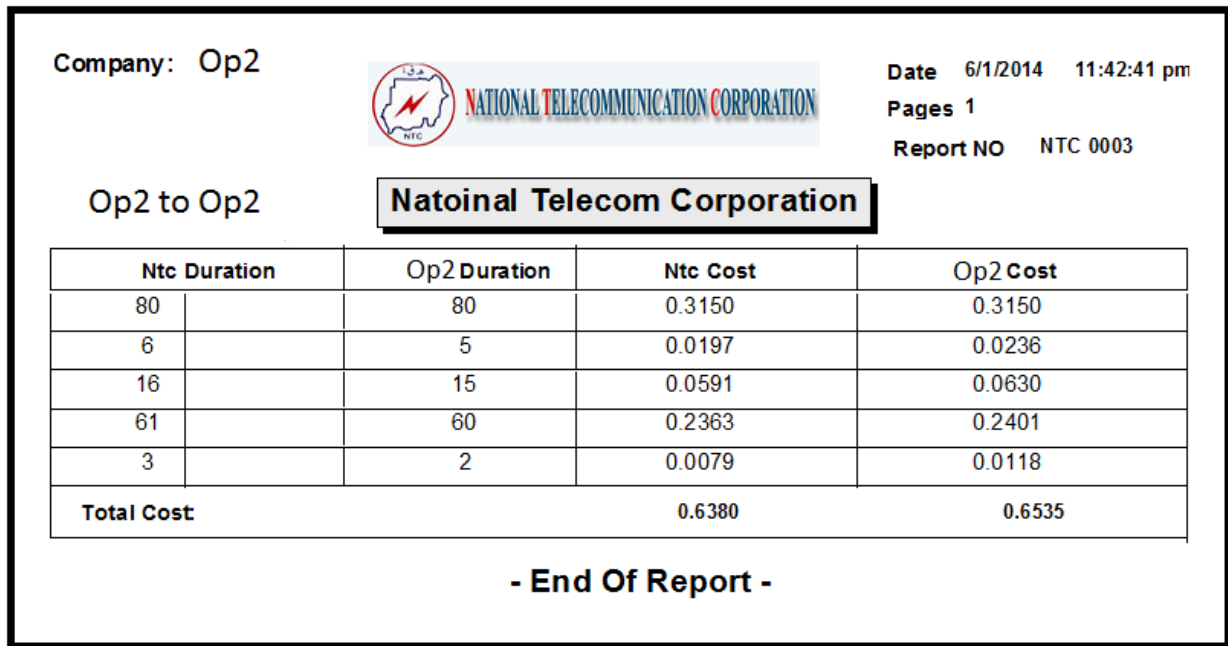

Figure (4.15) comparing results between Op2 to Op2 and the System (Op2 to Op2).

Figure (4.16) comparing cost when calling from Op2 to Op2 using Graph.

- The results show that the cost of call lacks some precision (over bill) and the time (start and end time of call) is also not accurate (over metering) when calling from Op2 to Op2 telecom, the graph (5.4).

4.2.1.2.2 Op2 Off-Net Calls:

- **Firstly Op2 to OP1 Telecom :**



Company: Op2		 NATIONAL TELECOMMUNICATION CORPORATION		Date 6/1/2014 11:51:54 pm				
Op2 to Op1				Pages 1				
				Report NO NTC 0002				
Call No	Duration	Price	Cost	Caller ID	Receiver ID	start Time	End Time	Date
6	10	0.0030	0.04	Op2	Op1	00:00:00.0	1900-01-01	2014-05-19
7	30	0.0030	0.12	Op2	Op1	00:00:00.0	1900-01-01	2014-05-19
8	60	0.0030	0.24	Op2	Op1	00:00:00.0	1900-01-01	2014-05-19
9	100	0.0030	0.39	Op2	Op1	00:00:00.0	1900-01-01	2014-05-19
10	6	0.0030	0.02	Op2	Op1	00:00:00.0	1900-01-01	2014-05-19
Total Cost			0.8112					
- End Of Report -								

Figure (4.17) the system results From Op2 to OP1 telecom.

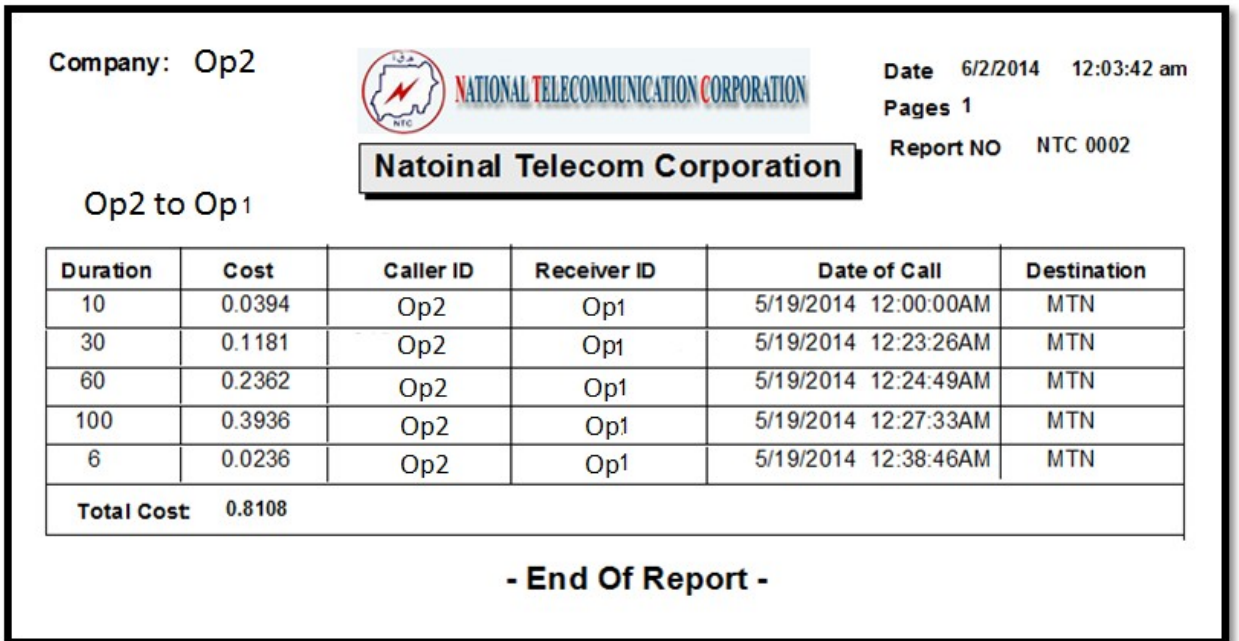

Figure (4.18) the Original results From Op2 to OP1 Telecom.

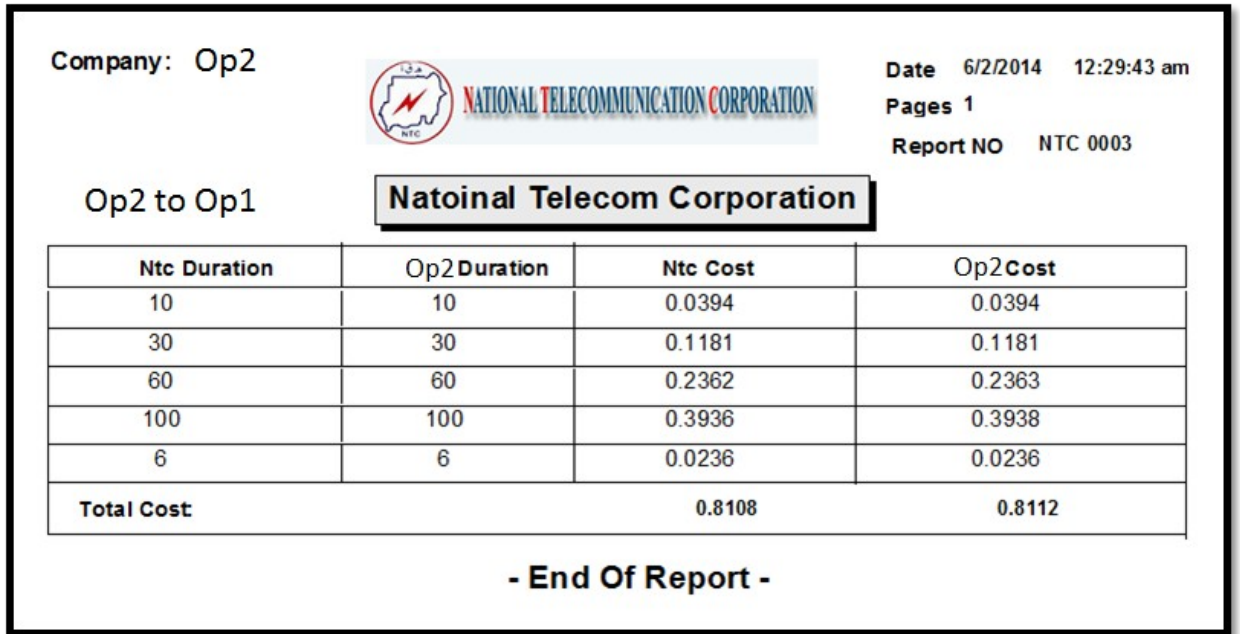

Figure (4.19) comparing results between Op2 to OP1 and the System (Op2 to OP1).

Figure (4.20) comparing cost when calling from Op2 to OP1 via Graph using the system total cost and Op2 total cost.

- The results above proved the accuracy of Op2' billing system in both cost (correctly bill) and time (correctly metering) of call.
- **Secondly Op2 to Op3 Telecom :**

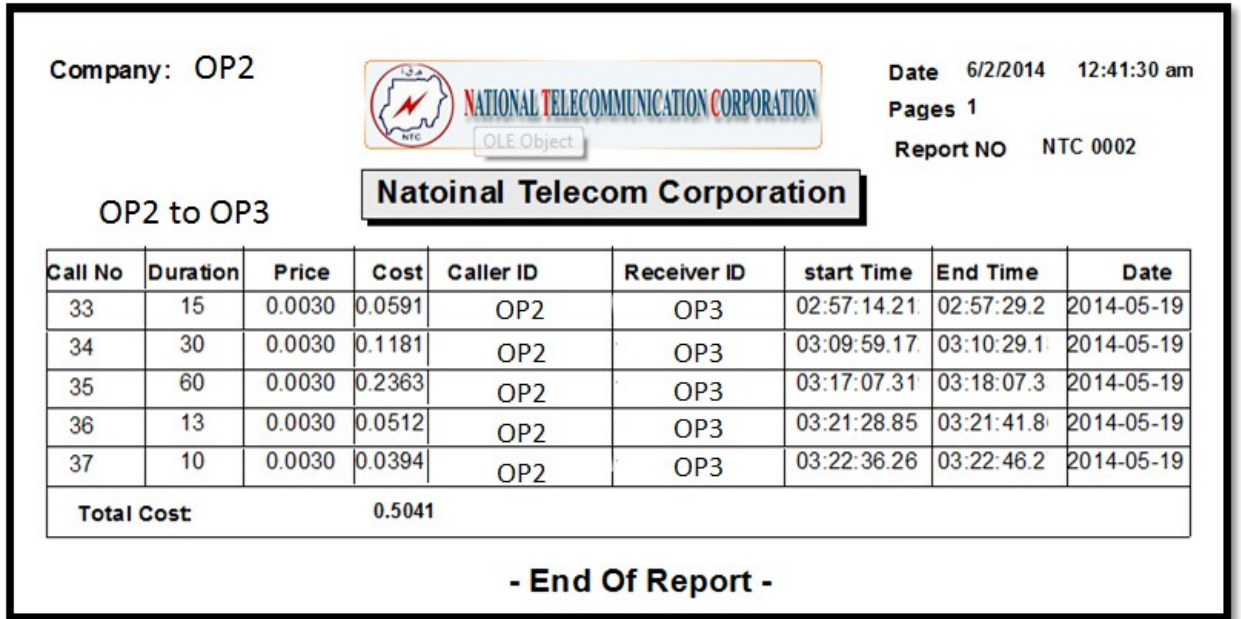

Figure (4.21) the system results From Op2 to Op3 telecom.

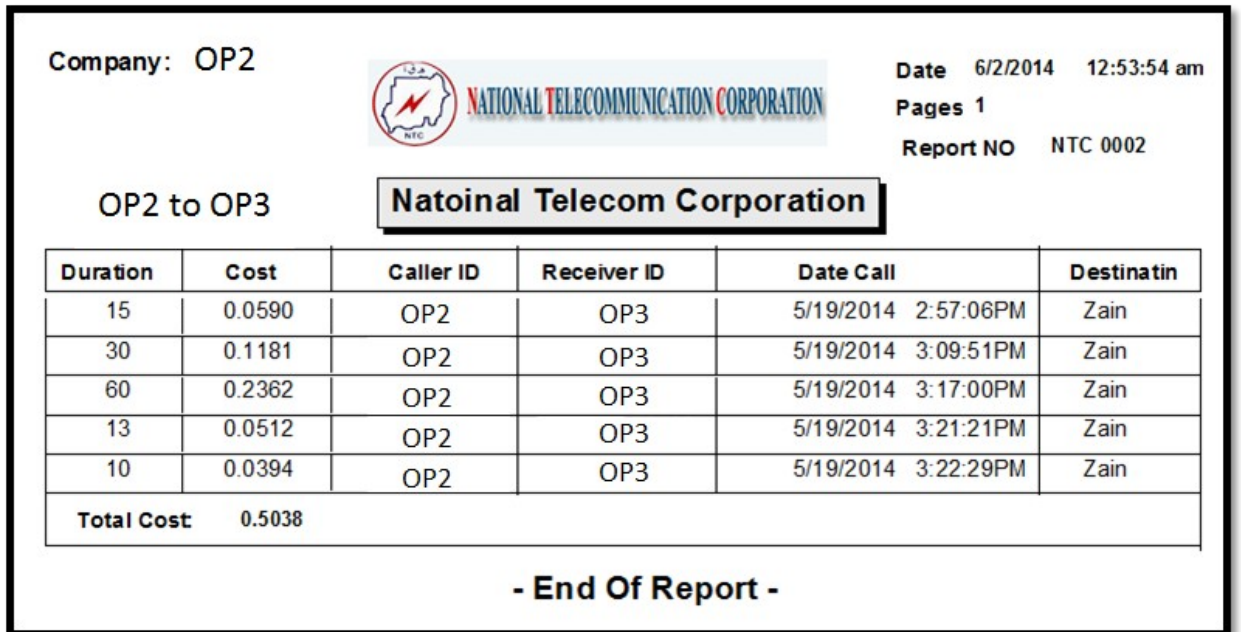

Figure (4.22) the original results fromOp2 to Op3 telecom.

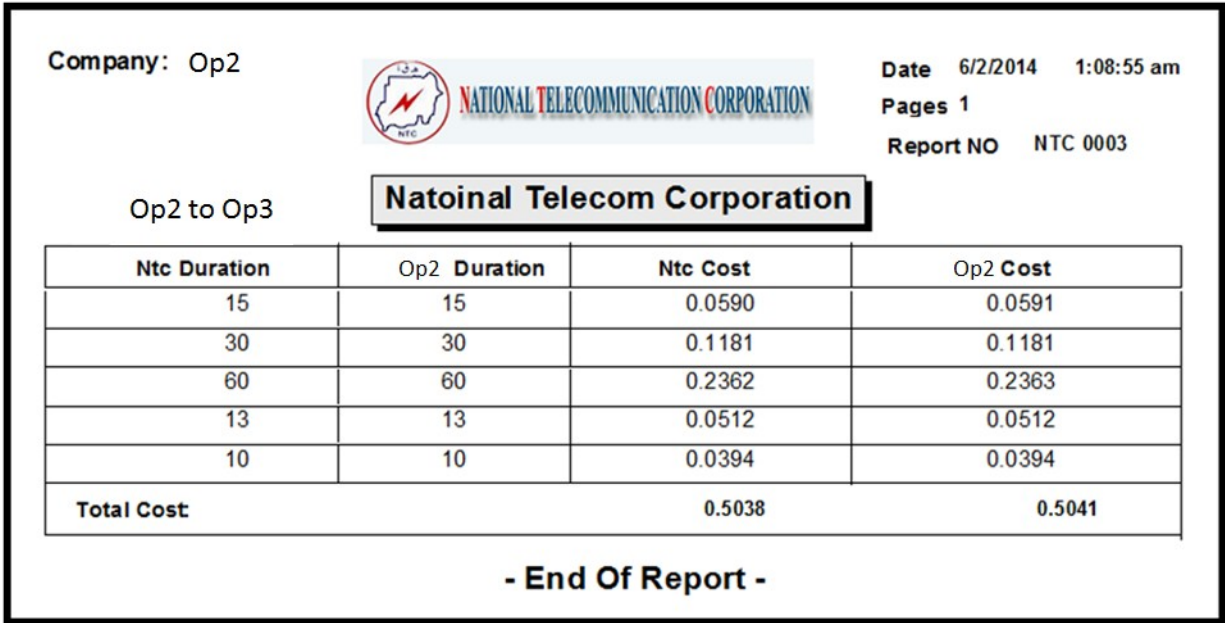

Figure (4.23) comparing results between Op2 to Op3, and the System (Op2 to Op3).

Figure (4.24) shows comparing cost when calling from Op2 to Op3 via Graph using the system total cost and Op3 total cost.

- Again the results above proved the accuracy of Op2' billing System in both cost (correctly bill) and time (Correctly metering) of call when calling from Op2 to Op3 telecom network.
- The graph (5.8) above explains that no different between both cost (system cost and Op2 telecom cost).

4.2.1.3 Metering and Cost of Call inside Op3 Telecom Company:

The test includes the on-net (the call inside Op3) and off-net (the call outside Op3).

Op3 On-Net 5.2.1.3.1 :Calls

Company: Op3		 NATIONAL TELECOMMUNICATION CORPORATION		Date 6/28/2014 11:56:03 am				
				Pages 1				
				Report NO NTC 0002				
Natoinal Telecom Corporation								
Op3 to Op3								
Call No	Duration	Price	Cost	Caller ID	Receiver ID	start Time	End Time	Date
20	10	0.0021	0.0932	Op3	Op3	01:04:12.287	01:04:22.302	2014-05-19
21	30	0.0021	0.1483	Op3	Op3	01:06:49.098	01:07:19.112	2014-05-19
22	60	0.0021	0.2310	Op3	Op3	01:09:36.190	01:10:36.203	2014-05-19
23	10	0.0021	0.0932	Op3	Op3	01:13:42.998	01:13:53.013	2014-05-19
24	120	0.0021	0.3964	Op3	Op3	01:16:23.772	01:18:23.783	2014-05-19
25	5	0.0021	0.0794	Op3	Op3	01:21:24.029	01:21:29.037	2014-05-19
26	15	0.0021	0.1070	Op3	Op3	07:47:42.694	07:47:57.701	2014-05-19
Total Cost			1.1485					
- End Of Report -								

Figure (4.25) the system results from Op3 to Op3 telecom.

Natoinal Telecom Corporation

OP3 to OP3

Call No	Duration	Price	Cost	Caller ID	Receiver ID	start Time	End Time	Date
20	10	0.0022	0.0945	OP3	OP3	01:04:12.287	01:04:22.302	2014-05-19
21	30	0.0022	0.1523	OP3	OP3	01:06:49.098	01:07:19.112	2014-05-19
22	60	0.0022	0.2389	Op3	OP3	01:09:36.190	01:10:36.203	2014-05-19
23	10	0.0022	0.0945	OP3	OP3	01:13:42.998	01:13:53.013	2014-05-19
24	120	0.0022	0.4121	OP3	OP3	01:16:23.772	01:18:23.783	2014-05-19
25	5	0.0022	0.0801	OP3	OP3	01:21:24.029	01:21:29.037	2014-05-19
26	15	0.0022	0.1070	OP3	OP3	07:47:42.694	07:47:57.701	2014-05-19
Total Cost			1.1794					

- End Of Report -

Figure (4.26) the Original results From Op3 to Op3 telecom.
 Figure (4.27) comparing results between Op3 to Op3 and the System (Op3 to Op3).

Figure (4.28) comparing cost when calling from Op3 to Op3 using Graph.

- The results above proved the accuracy of Op3' billing system in both cost (correctly bill) and time (correctly metering) of call. When calling from Op3 to Op3 telecom, the graph (4.28) explains that.

4.2.1.3.2 Op3 Off-Net Calls:

- **Firstly Op3 to OP1 Telecom:**

Company: Zain Telecom		 NATIONAL TELECOMMUNICATION CORPORATION		Date 6/27/2014 7:02:40 pm			
				Pages 1			
				Report NO NTC 0002			
		Natoinal Telecom Corporation					
Zain to MTN							
Call No	Duration	Cost	Caller ID	Receiver ID	start Time	End Time	Date
11	10	0.1072	op3	op1	10:05:51:221	10:05:61:452	2014-05-19
12	15	0.1280	op3	op1	10:07:50:24	10:08:05:847	2014-05-19
13	60	0.3149	op3	op1	10:09:39:420	10:10:39:54	2014-05-19
14	5	0.0864	op3	op1	10:12:10 :852	10:12:15:301	2014-05-19
15	20	.01487	op3	op1	10:12:56:850	10:13:16:66	2014-05-19
16	2	0.0739	op3	op1	10:13:44:520	10:13:45:422	2014-05-19
Total Cost		0.8592					

- End Of Report -

Figure (4.29) the original results from Op3 to OP1 teleco



Company: Op3		 NATIONAL TELECOMMUNICATION CORPORATION		Date 6/27/2014 7:22:47 pm	
				Pages 1	
				Report NO NTC 0002	
Op3 to Op1		Natoinal Telecom Corporation			
Duration	Cost	Caller ID	Receiver ID	start Time	Date
10	0.1072	Op3	Op1	10:05:51	05/19/2014
15	0.1280	Op3	Op1	10:07:50	05/19/2014
60	0.3149	Op3	Op1	10:09:39	05/19/2014
5	0.0864	Op3	Op1	10:12:10	05/19/2014
20	0.1487	Op3	Op1	10:12:56	05/19/2014
2	0.0739	Op3	Op1	10:13:44	05/19/2014
Total Cost		0.8592			
- End Of Report -					

Figure (4.30) the Original results From Op3 to OP1 Telecom.

Company: Op3



Date 7/5/2014 12:16:24 pm
Pages 1
Report NO NTC 0003

Op3 to Op1

Natoinal Telecom Corporation

Ntc Duration	Op3 Duration	Ntc Cost	Op3 Cost
10	10	0.1072	0.1072
15	15	0.1280	0.1280
60	60	0.3149	0.3149
5	5	0.0864	0.0864
20	20	0.1487	0.1487
2	2	0.0739	0.0739
Total Cost		0.8591	0.8592

- End Of Report -

Figure (4.31) comparing results between Op3 to OP1 and the System (Op3 to OP1).

Figure (4.32) comparing cost when calling from Op3 to OP1 using Graph.

- The results show that the cost of call is accurate in both cost (correctly bill) and time (correctly metering) of call. When calling from Op3 to Op1 telecom, the graph (4.32) explains that.
- **Secondly Op3 to Op2 Telecom :**

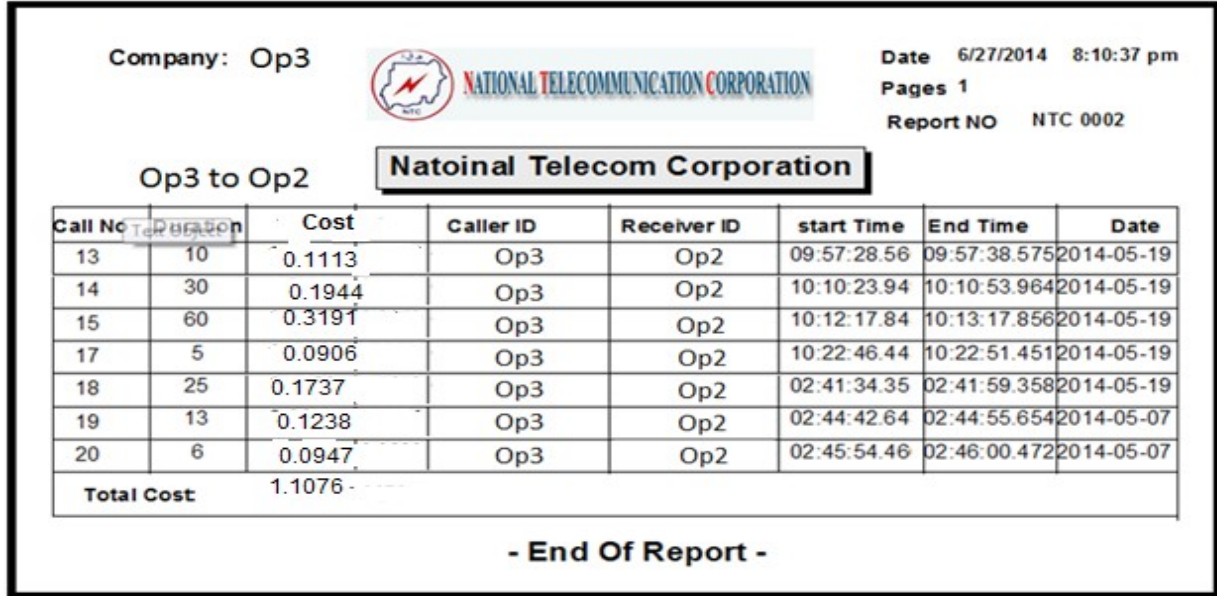

Figure (4.33) thesystem results from Op3 to Op2 telecom.

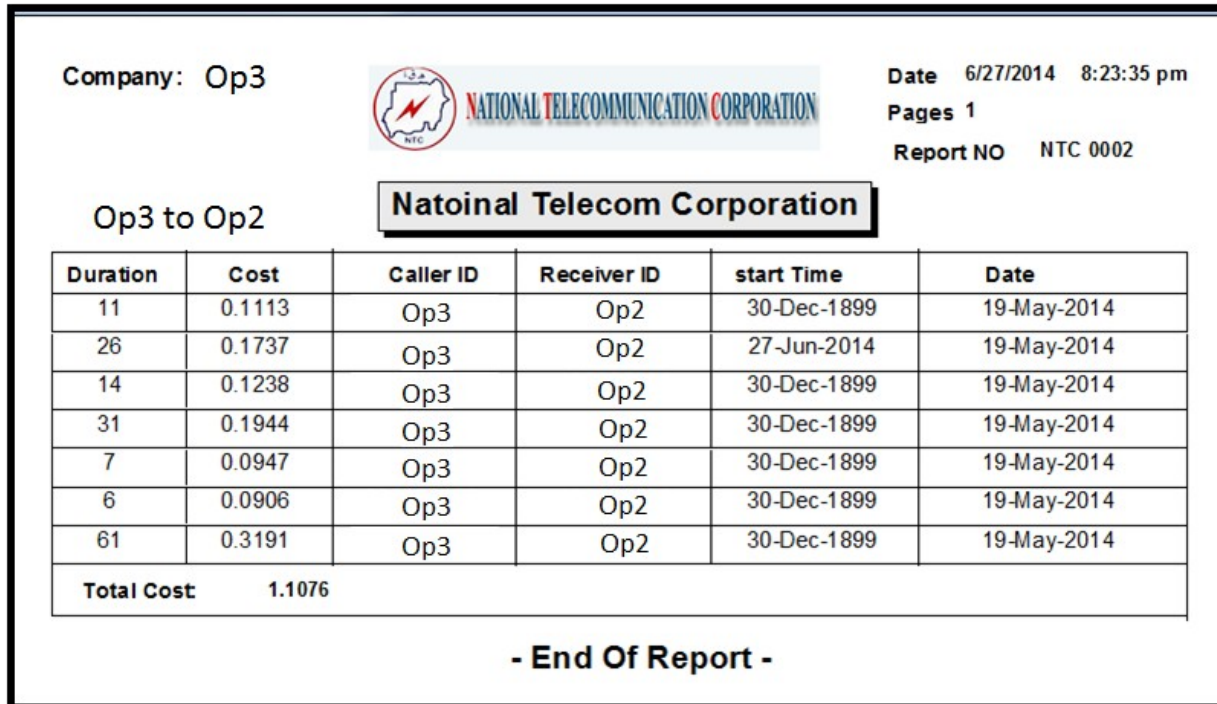

Figure (4.34) the Original results From Op3 to Op2 Telecom.

Company: OP3 Telecom



Date 2/25/2015 1:26:29 am

Pages 1

Report NO NTC 0003

Natoinal Telecom Corporation

From Op3 to Op2

Ntc Duration	Op3 Duration	Ntc Cost	Op3 Cost
10.0000	10.0000	0.1113	0.1113
25.0000	25.0000	0.1737	0.1737
13.0000	13.0000	0.1238	0.1238
30.0000	30.0000	0.1944	0.1944
6.0000	6.0000	0.0947	0.0947
5.0000	5.0000	0.0906	0.0906
60.0000	60.0000	0.3191	0.3191
Total Cost		1.1076	1.1076

- End Of Report -

Figure (4.35) comparing results between Op3 to Op2 and the System (Op3 to Op2).

Figure (4.36) shows comparing cost when calling from Op3 to Op2 using Graph.

- The results show that the cost of call is accurate in both cost (correctly bill) and time (correctly metering) of call. When calling from Op3 to Op2 telecom, the graph (4.36) explains that.

CHAPTER 5

CONCLUSION AND RECOMMENDATIONS

5.1 Conclusion:

A system had been developed to measure, analyze and investigate the quality of billing systems in Sudanese telecommunication companies (Op3, Op2, Op1, and Op4), This system has been generated

using GSM\Modem technology which considers as the heart of this research.

The main idea in this research is solving the problem depends on the voice calls. the system developed to calculate the total cost and time (starts and end time) of calls.

The system has been done by: identifying the duration of call, Determining the Price List of the call according to selected telecom company, Receiving call by using ATA command to answer the call, Calculating the accurate cost of call according to specified price and call duration, by multiplying the call duration in selected price to generate the total cost of call, Generating Reports which used to generate Actual reports from the voice calls, price/cost/Quality to make comparisons between actual voice calls throw GSM/Modem and ordinary voice calls , throw Billing Systems that telecommunication companies generated.

The reports have been generated using crystal report technology. The thesis experiments proved the accuracy of billing system inside OP1network and outside OP1 network to Op3 telecom company, but it is lacks some precision when calling from OP1 to Op2 telecom company, also the results proved accuracy of billing in Op2 telecom company when calling from Op2 to Op3 telecom company and OP1 telecom company (Off-Net), but it is lacks some precision when calling from Op2to Op2 (On-Net), and also the results proved accuracy of the billing system inside Op3 Telecom including On Net Calls when calling from Op3 to Op3 and Off Net Calls when calling from Op3 to OP1telecom and Op3 to Op2telecom.

5.2 Recommendations:

To make this system more reliable and provide attractive services it is recommend doing some tasks:

- Improve the system to measure and investigate the quality of video calls.
- Improve the system to measure and investigate the quality of international voice calls (Roaming).
- Improve the system to measure and investigate the quality of internet voice over IP calls (VOIP).
- Develop the system to be as mobile application on smart phones.

References:

- [1][Online]. <http://www.siscomgroup.ca/index.php> 8 may 2014 13:32 PM
- [2]"Aguilar, M.C., The proposal of the Billing System Of Nesron Auto Painting Services.," p. 5, 2013.
- [3]Stamati Crook, "Telecoms Billing Manual," pp. (4-7), Jan 2009.
- [4][Online]. www.tutorialspoint.com/telecom-billing/system-architecture.htm 10 may 2014 04:5 AM.
- [5]Hong Kong, "Billing and Metering Accuracy of Public Telecommunications Services in Hong Kong Statement of the Telecommunications , " August 2000.
- [6]India, "TELECOM REGULATORY AUTHORITY OF INDIA (Expression of

Interest for Empanelment of Auditors to certify the Metering and Billing System of Telecom Service Providers). , " December 2013.

- [7] Hong Kong, "Quality Assurance Manual for Billing and Metering Integrity Scheme (TELECOMMUNICATIONS AUTHORITY HONG KONG) ," Sept 2000.
- [8] Vitesh J. Jinabhai, "An Investigation into Telecommunications Billing System Testing Processes," p. 3.
- [9] "Telecommunications Billing in the Competitive Wire line Area Hong Kong ," May 2007.
- [10] MS: Matti Swan Elisa Research, "Total cost of charging and billing: CapEx and OpEx ".
- [11] "Smart Meters and Smart Meter Systems: A Metering Industry Perspective An EEI-AEIC-UTC White Paper," March 2011.
- [12] Muhammad Asif Khan, "An Empirical Assessment of Service Quality of Cellular Mobile Telephone Operators in Pakistan.," October 2010.
- [13] [Online]. <http://www.wisegeek.com/what-is-a-gsm-modem.htm> 15 may 2014 2:30 PM.
- [14] [Online]. http://www.doc.ic.ac.uk/~nd/surprise_96/journal/vol/report.html 16 may 2014 10:22 AM.
- [15] [Online]. <http://msdn.microsoft.com/enus/library/vstudio/w0x726c2%28v=vs.100%29.aspx> 16 may 2014 12:40 AM
- [16] [Online]. [The C# Programming Language Anders Hejlsberg Scott Wiltamuth Peter Golde](#) 16 may 2014 14:40 AM.
- [17] [Online]. <http://www.ibm.com/developerworks/rational/library/769.html> may 204 10:12 PM.
- [18] [Online]. <http://www.developershome.com/sms/atCommandsIntro.asp> 30 may 2014 08:10AM.

Appendix A:

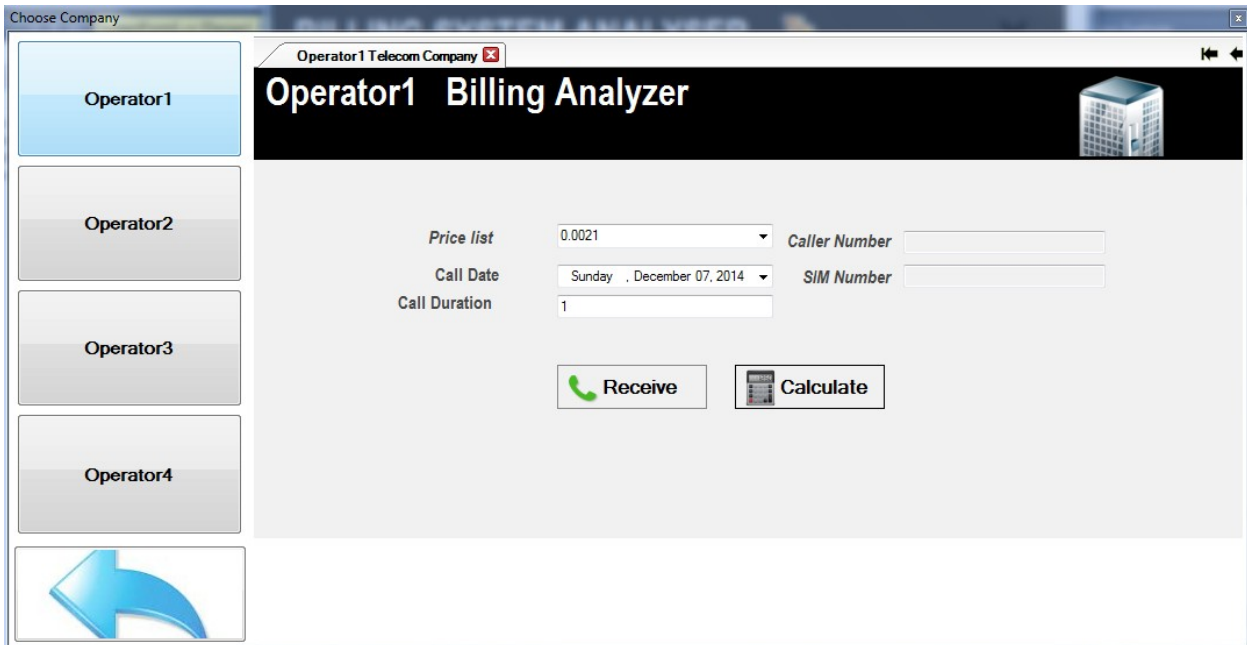

Figure (A.1) OP1billing analyzer screen.

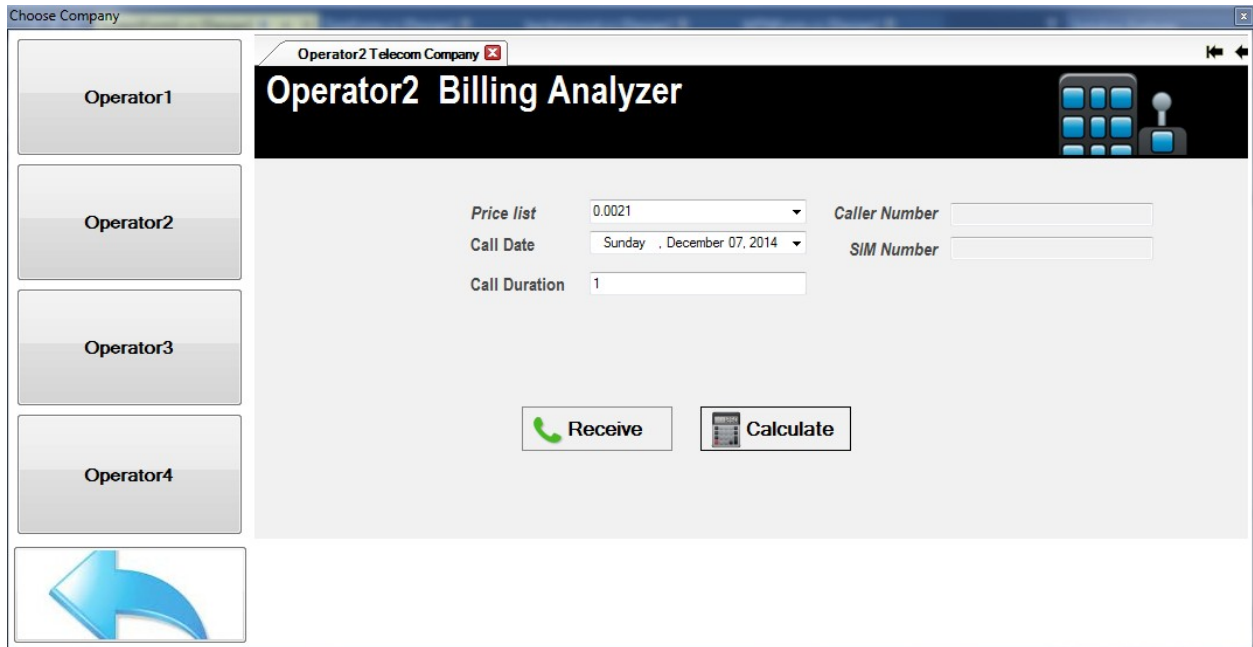

Figure (A.2) Op3 Billing analyzer screen.

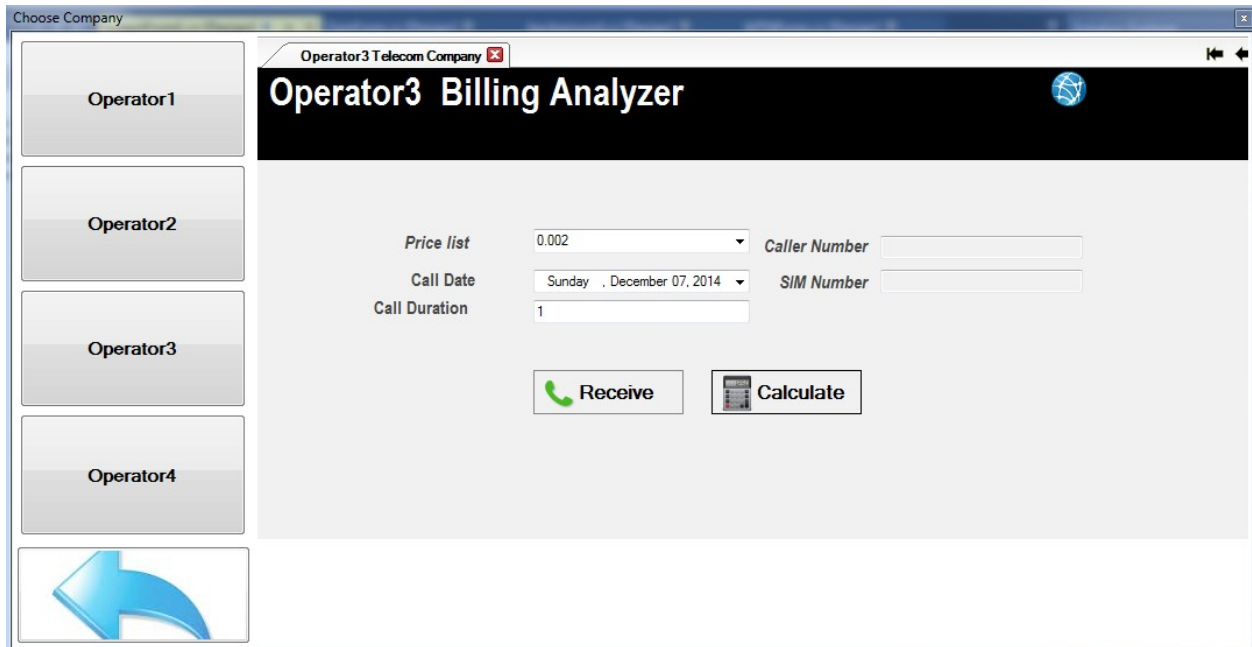

Figure (A.3) Op2 Billing analyzer screen.

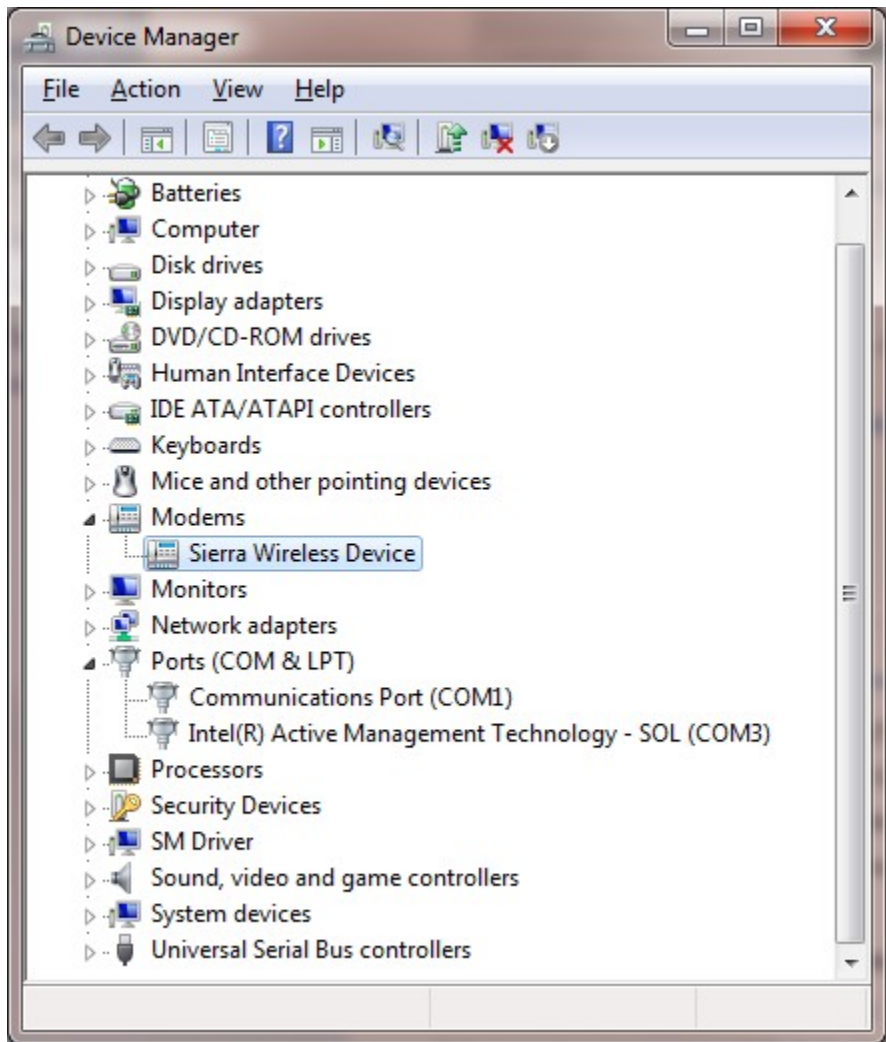

Figure (A.4) shows setup GSM Modem in windows 7.

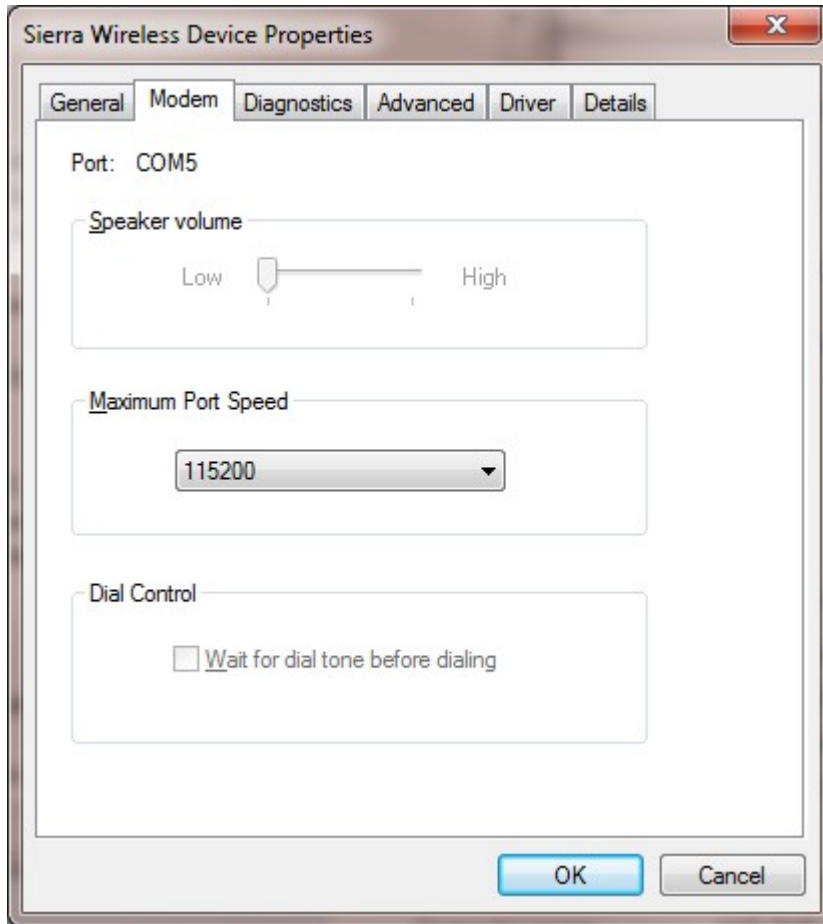

Figure (A.5) shows setup GSM Modem in windows 7

